

NOTE:  
Work this Index with Index No. 20600 - Notes and Details for Square Prestressed Concrete Piles and Index No. 20601 - Square Prestressed Concrete Pile Splices.

ELEVATION

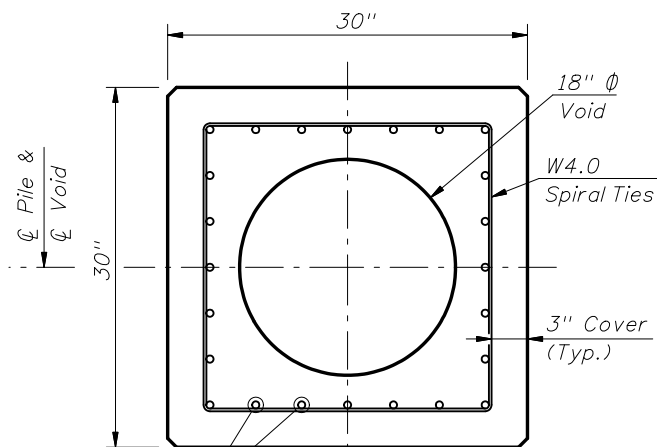

Prestressing Strands, see Alternate Strand Patterns

SECTION B-B  
(See Pile Splice Reinforcement Details)

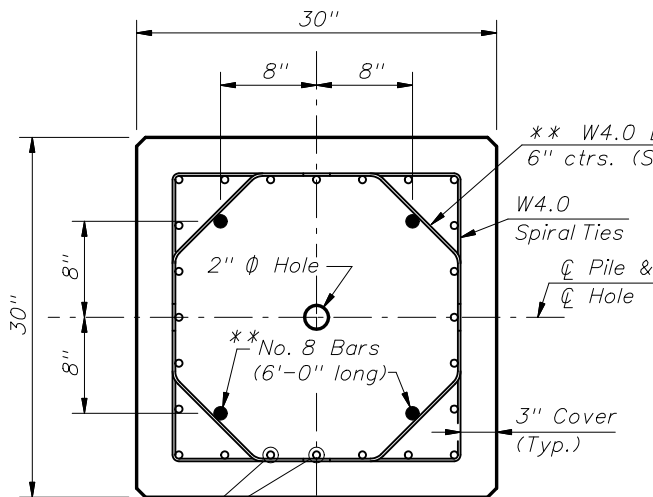

Prestressing Strands, see Alternate Strand Patterns

SECTION C-C  
(See Pile Splice Reinforcement Details)

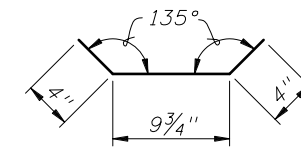

W4.0 DIAGONAL TIE DETAIL

\*\* Omit 4 ~ No. 8 Bars and Diagonal Ties in pre-planned mechanical splice.

NOTES:

- Venting shall be provided by the use of a 1"  $\phi$  PVC conduit through a substructure cap or column. Voids between segments of spliced piles shall be connected by 2"  $\phi$  hole(s).
- Any of the given Alternate Strand Patterns may be utilized. The strands shall be located as follows: Place one strand at each corner and place the remaining strands equally spaced between the corner strands. The total strand pattern shall be concentric with the nominal concrete section of the pile.
- CONTRACTOR OPTION: The 30" pile may be cast SOLID by omitting the 18"  $\phi$  void and the 2"  $\phi$  vent hole. In this event, the Contractor shall submit calculations for approval and a proposed strand configuration that provide net prestressing after losses equal to 1000 psi. Alternate configurations for the Diagonal Ties, to maintain the position of the 4 ~ No. 8 Bars, may be approved by the Engineer.

ALTERNATE STRAND PATTERNS

- 20 ~ 3/16"  $\phi$ , Grade 270 (Spec) LRS, at 39.7 kips
- 20 ~ 3/16"  $\phi$ , Grade 270 LRS, at 39.0 kips
- 20 ~ 0.6"  $\phi$ , Grade 270 LRS, at 41 kips
- 24 ~ 1/2"  $\phi$ , Grade 270 (Spec) LRS, at 34.0 kips
- 24 ~ 3/16"  $\phi$ , Grade 270 SR, at 35 kips
- 24 ~ 3/16"  $\phi$ , Grade 270 (Spec) SR, at 35.2 kips
- 28 ~ 1/2"  $\phi$ , Grade 270 LRS, at 29.0 kips
- 28 ~ 1/2"  $\phi$ , Grade 270 (Spec) SR, at 30.2 kips

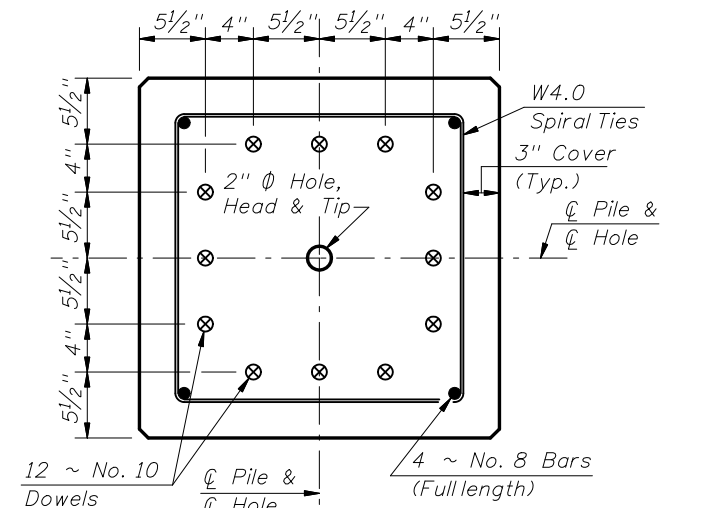

SECTION D-D  
(See Non-drivable Unforeseen Reinforced Precast Pile Splice Detail)

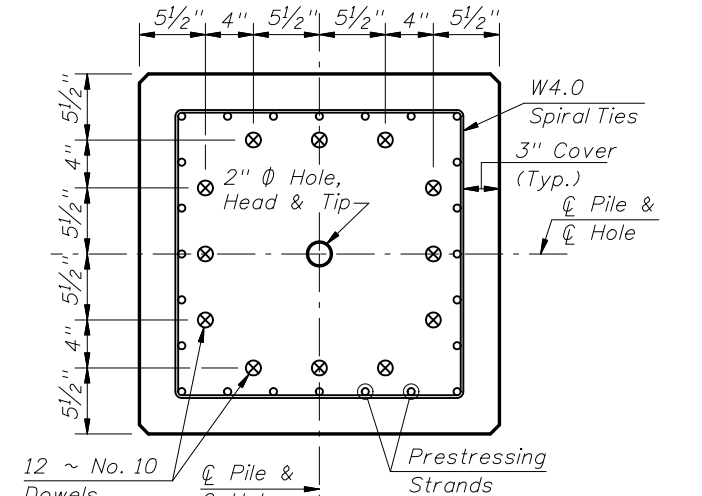

SECTION E-E  
(See Drivable Prestressed Precast Pile Splice Detail)

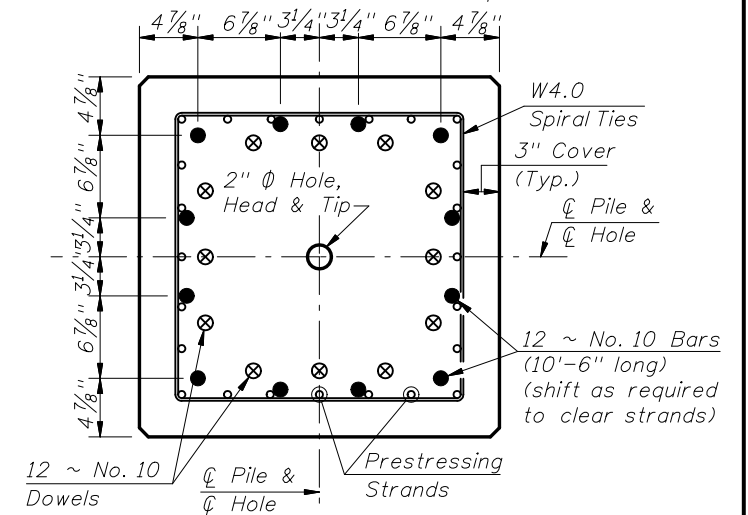

SECTION F-F  
(See Drivable Preplanned Pile Splice Detail)

PILE SPLICE DETAILS

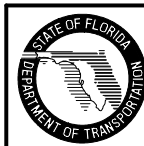

2008 FDOT Design Standards

30" SQUARE PRESTRESSED CONCRETE PILE

Last Revision 07/01/07  
Sheet No. 1 of 1  
Index No. 20630