

NOTES:

1. For Sections D-D, E-E, & F-F see Index Nos. 20612, 20614, 20618, 20620, 20624 or 20630 for applicable concrete pile size.
2. Prestressing strands, spiral ties and/or reinforcement are not shown for clarity.
3. In cases where pile splices are desired due to length limitations in shipping and/or handling, the "Drivable Preplanned Prestressed Precast Splice Detail" shall be used. Mechanical Pile Splices contained on the Qualified Products List (QPL) may also be used.
4. When preformed dowelholes are utilized, the 1" spiral tie pitch shall be continued to 4'-0" below the head of the pile, and the preforming material shall be removed. See Index Nos. 20618, 20620 & 20624.

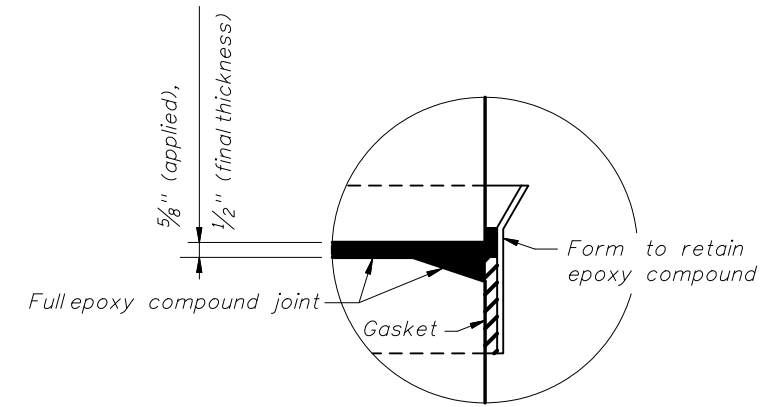

DETAIL A

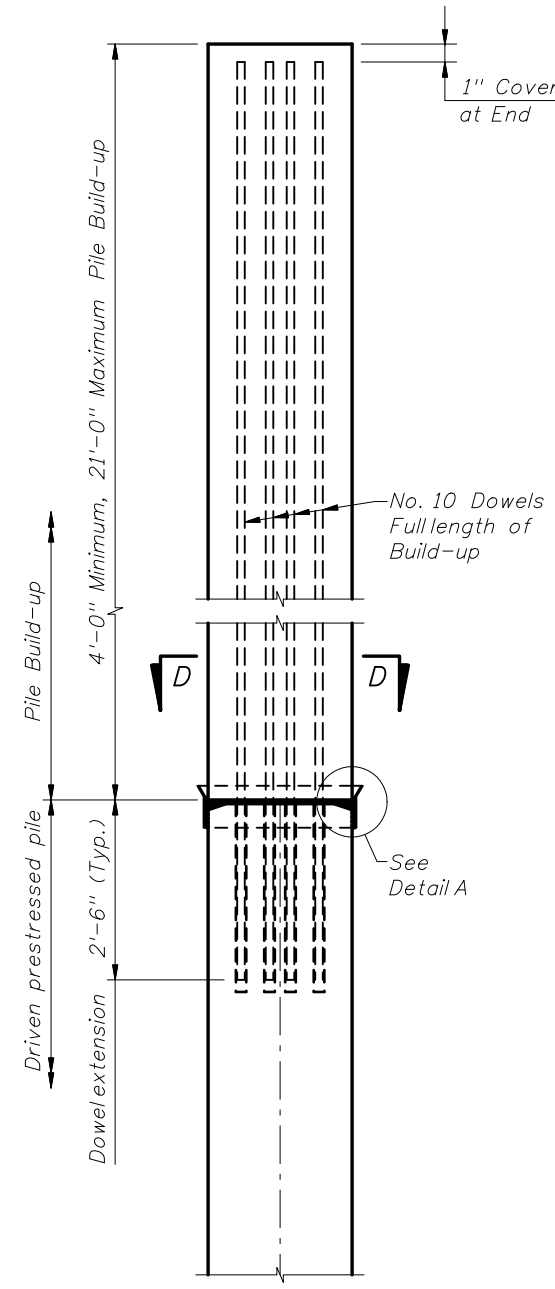

NONDRIVABLE UNFORESEEN REINFORCED PRECAST PILE BUILD-UP DETAIL

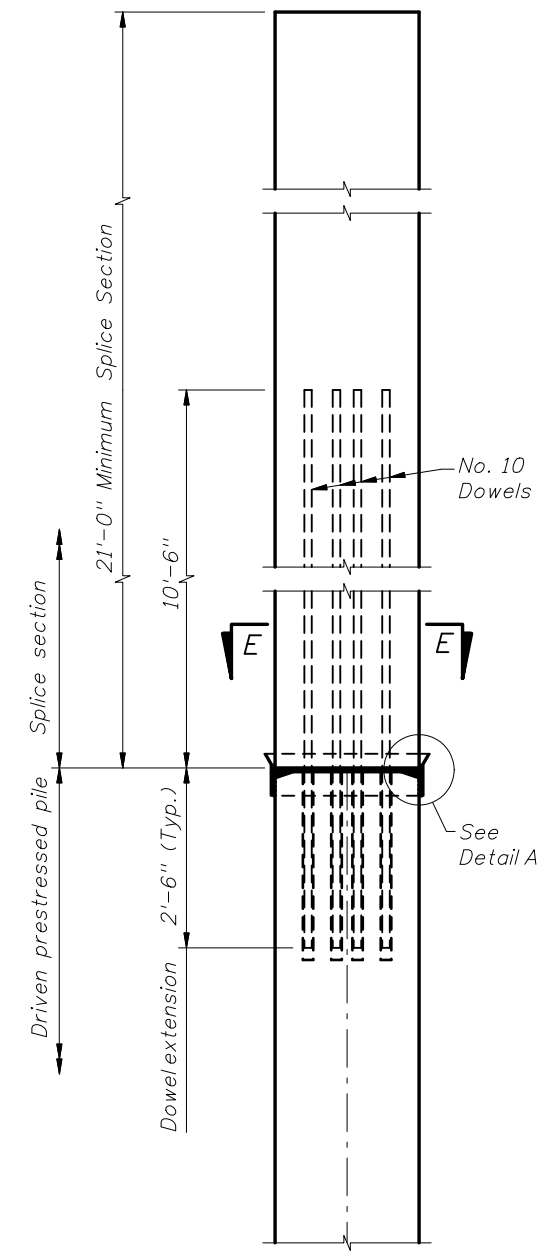

DRIVABLE UNFORESEEN PRESTRESSED PRECAST PILE SPLICE DETAIL

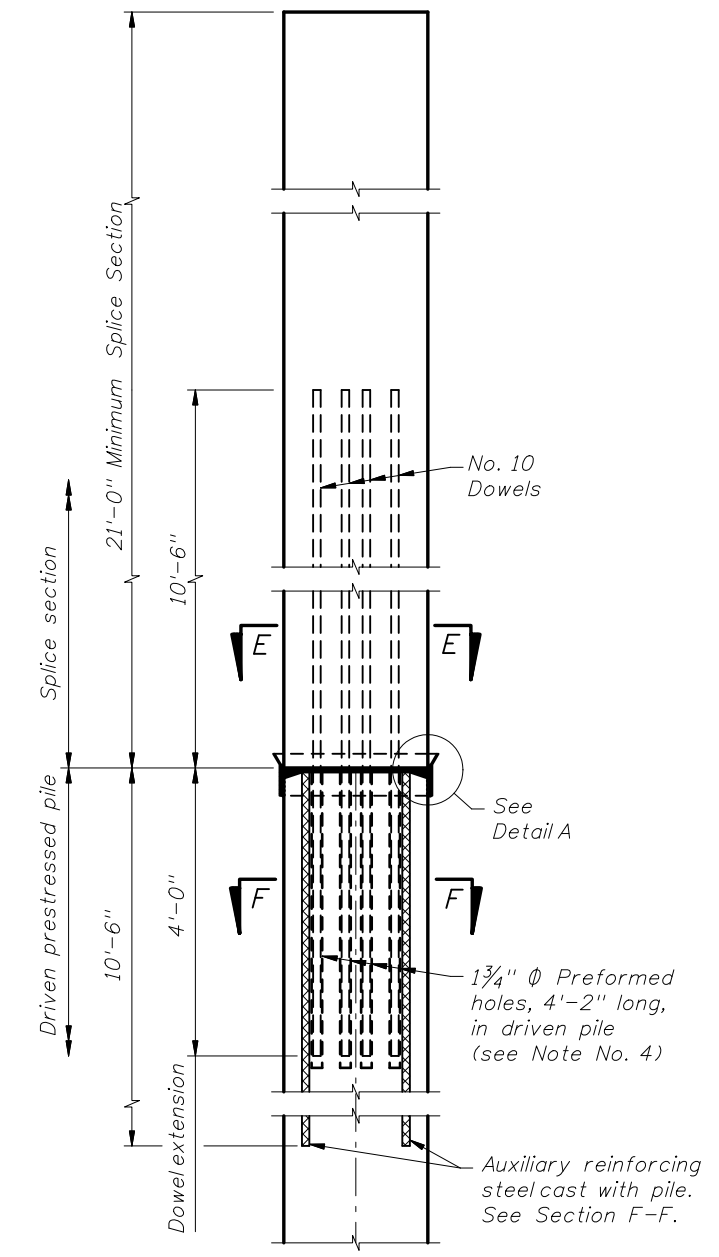

DRIVABLE PREPLANNED PRESTRESSED PRECAST PILE SPLICE DETAIL

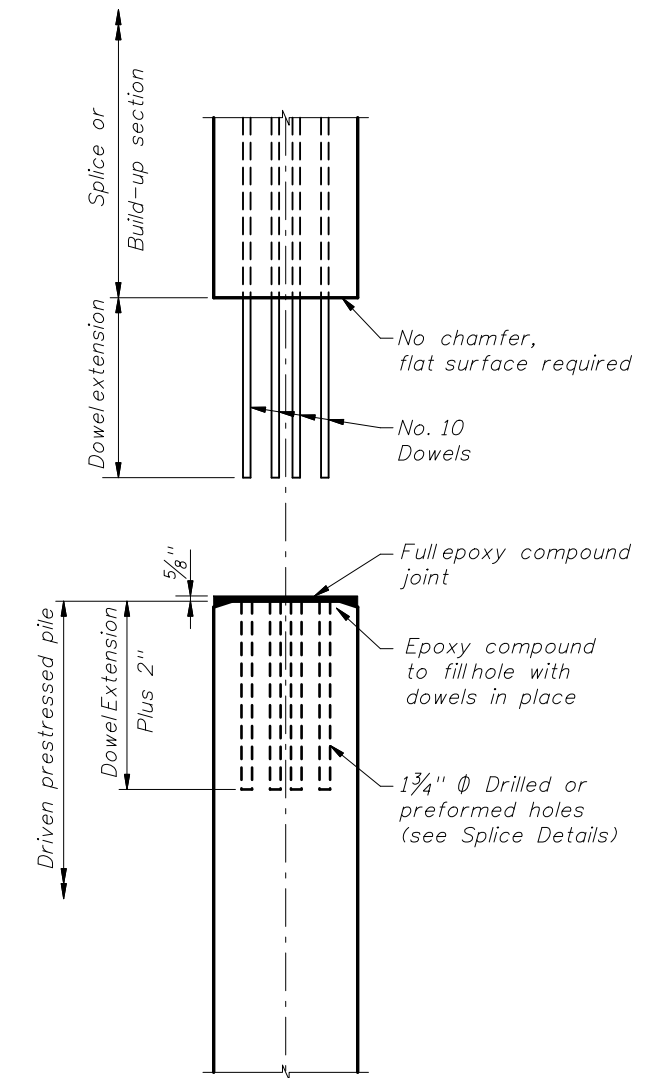

TYPICAL SPLICE BEFORE BONDING