

* This Bar A4 shall be 1'-2" shorter than other A4 bars for T = 12".
 ** This Bar A4 (not shown in elevation) is included only if T = 12".

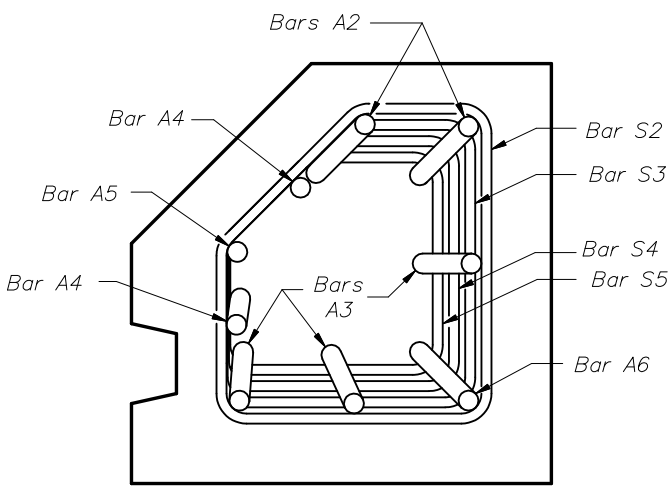

STIRRUP DIMENSIONS						
θ	T (in.)	BAR MARK	R1	R2	R3	
90°	10	S1	7"	5 3/4"	7"	
		S2	7"	8"	4 3/4"	
		S3	6 1/4"	7 1/4"	4 3/4"	
		S4	5 1/2"	6 1/2"	4 3/4"	
		S5	4 3/4"	5 3/4"	4 3/4"	
90°	12	S1	9"	4 3/4"	9"	
		S2	9"	7"	6 3/4"	
		S3	8 1/4"	6 1/4"	6 3/4"	
		S4	7 1/2"	5 1/2"	6 3/4"	
		S5	6 3/4"	4 3/4"	6 3/4"	

SHEET PILE DIMENSIONS		
T (in.)	10	12
Y (in.)	3 3/16	4 3/16
Z (in.)	3	4

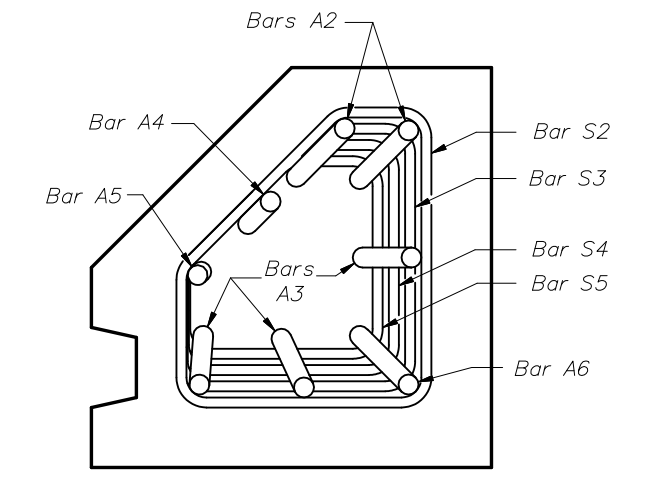
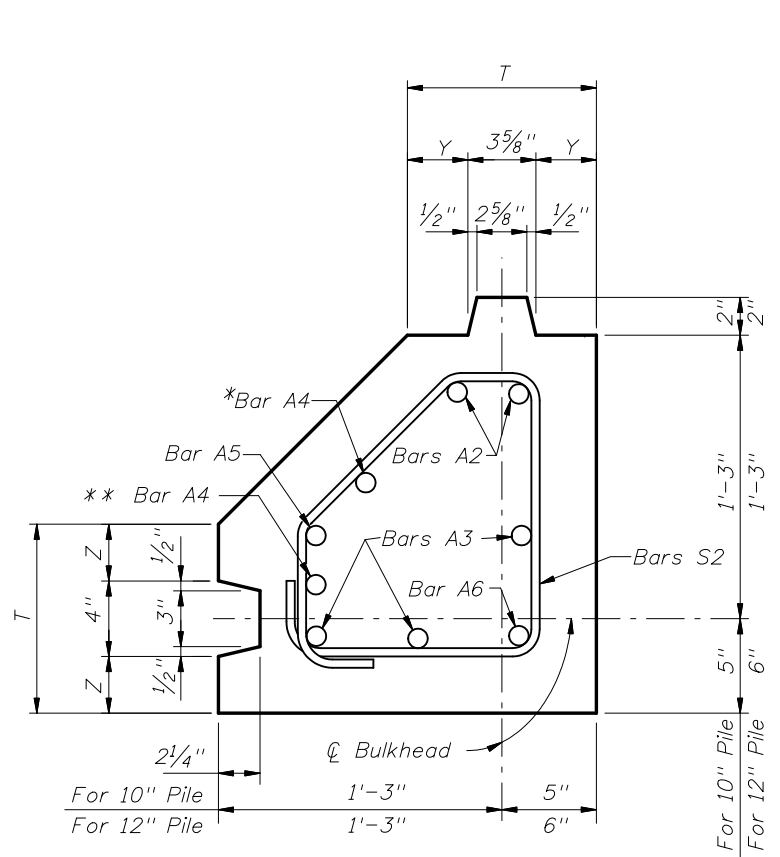
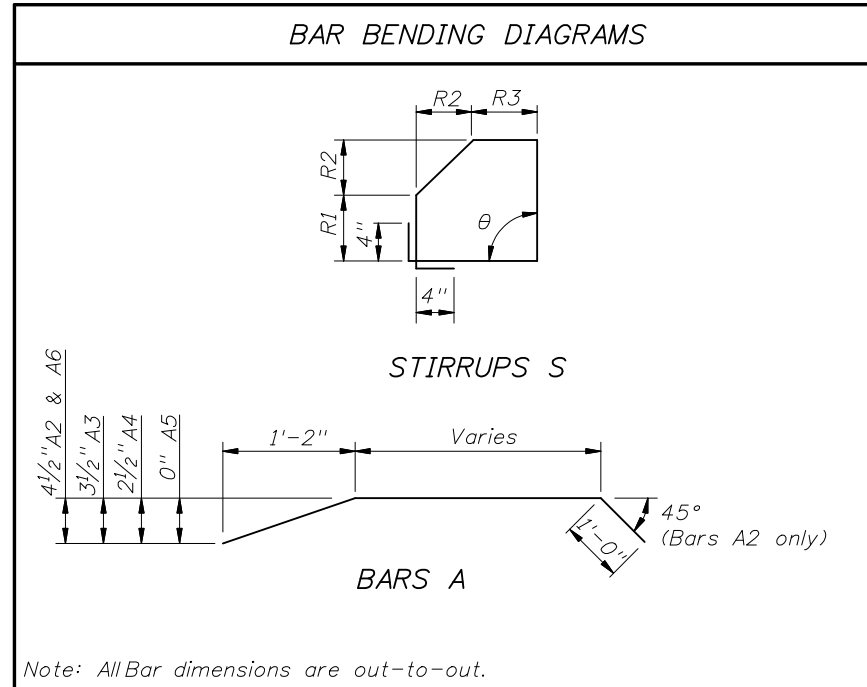

- NOTES:**
1. Work this standard with Index No. 20400.
 2. All bar dimensions are out-to-out.
 3. Bars A are #8 and Bars S are #4.
 4. This drawing includes information for precast Corner Piles for 10" and 12" thick Sheet Pile systems. The details apply to both thicknesses but the bar configurations change slightly according to the thickness values used.
 5. If Type "C" pile is used as a Starter Pile show tongue on both sides of pile from Dim. "X" down. Show dimensions for Bars S2, S3, S4 & S5 in shop drawings.
 6. If tongue must be on opposite side (Groove Side) from that shown, all dimensions and reinforcement shall follow the corresponding Tongue or Groove side.
 7. For Dimensions L and X see Sheet Pile Data Table in Structures Plans.