

SHEET PILE DESIGN CRITERIA AND NOTES

INSTRUCTION TO DESIGNER:
 The bottom of the "X" dimension shall be 1'-8" below the mud line.
 The tip elevation of Concrete Sheet Piles shall be determined by the Geotechnical Engineer.

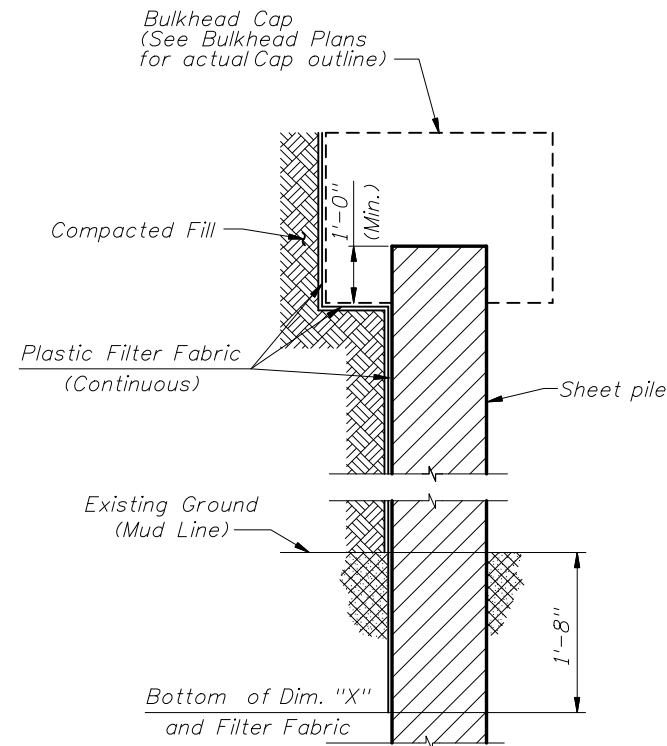

SECTION THRU BULKHEAD
 (Showing Plastic Filter Fabric)

CROSS REFERENCES:
 For Dimensions L and X see Sheet Pile Data Table in Structures Plans.

DESCRIPTION:
 Design Standards Index Series No. 20400 include details for three types of piles with two thicknesses. Types "B" and "C" piles (corner piles) are of reinforced concrete construction, and Type "A" is of prestressed concrete construction. The piles shall be manufactured, cured and installed in accordance with the requirements of the contract documents.

MATERIALS: (for materials not listed refer to the Specifications)
CONCRETE
 Class: V (Special) for slightly and moderately aggressive environments
 V (Special w/ Silica Fume) for extremely aggressive environment
 Unit weight: 150 pcf
 Modulus of Elasticity: Based on the use of Florida limerock concrete

REINFORCING STEEL
 Grade: 60,000 psi ASTM A615

PRESTRESSING STEEL
 Grade: 270,000 psi (Low-Relaxation Strand)

DESIGN PARAMETERS:
 Type "A"
 Concrete Compressive Strength at release of prestressing: 4000 psi minimum
 Uniform compression after prestressing losses: 1000 psi minimum
 Pick-up, Storage and Transportation: 0.0 psi tension with 1.5 times pile self weight
 Types "B" & "C"
 Pick-up, Storage and Transportation: Minimum compressive strength $f'_{ci} \geq 4000$ psi required.

ENVIRONMENT:
 The pile designs are applicable to all Environments.

PLASTIC FILTER FABRIC:
 The plastic filter fabric shall extend to the bottom of the "X" dimension.

PILE PICK-UP AND HANDLING:
 Type "A"
 Pick-up of pile may be either a single point pick-up or a two point pick-up as shown below.
 Types "B" & "C"
 Two point pick-up for lifting out of forms & two point support for storage & transportation.
 Single point pick-up for installation only.

PILE FIT-UP:
 The 2'-6" Sheet Pile dimension is nominal. This dimension may be shortened by the Manufacturer up to 1/2" to allow for Sheet Pile fit-up in its final position. Minimum Sheet Pile width is 2'-5 1/2". No changes shall be made to the tongues or grooves.

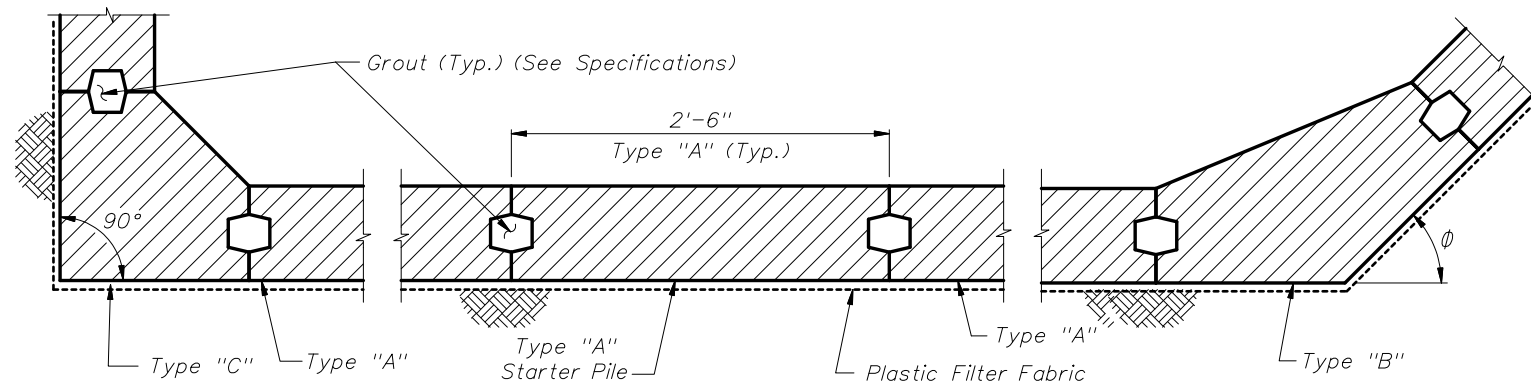

DETAIL "A"
 (Cap and Anchoring System Not Shown)
 (Section Taken Above Dimension "X")

NOTE: Detail "A" shows a Part-Plan View of an assumed bulkhead. See Bulkhead plans for actual Plan View.

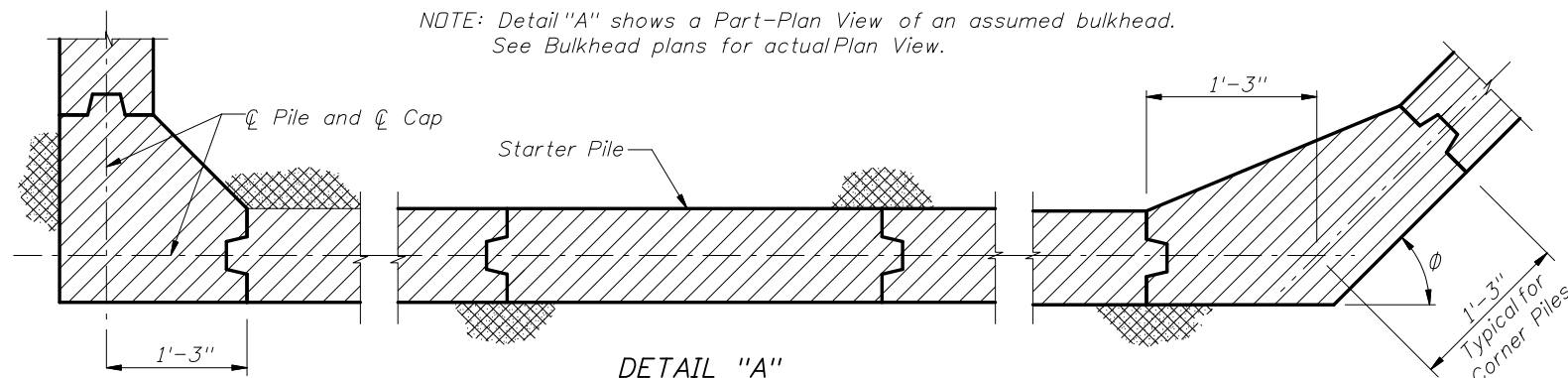

DETAIL "A"
 (Section Taken Below Dimension "X")

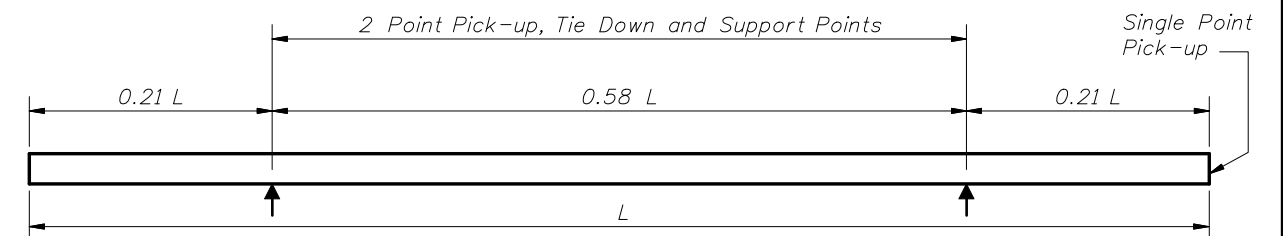

PILE STORAGE AND TRANSPORTATION SUPPORT DETAILS



2008 FDOT Design Standards

**NOTES AND DETAILS FOR
 PRECAST CONCRETE SHEET PILES**

Last Revision	Sheet No.
01/01/06	1 of 1
Index No.	
20400	