

FIGURE A

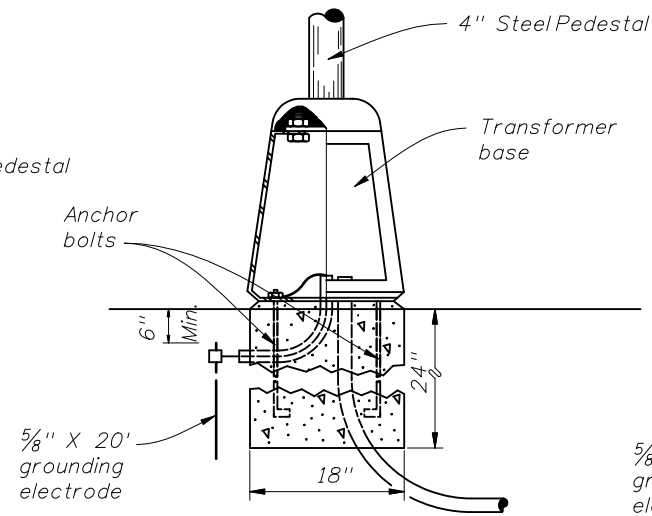

FIGURE B

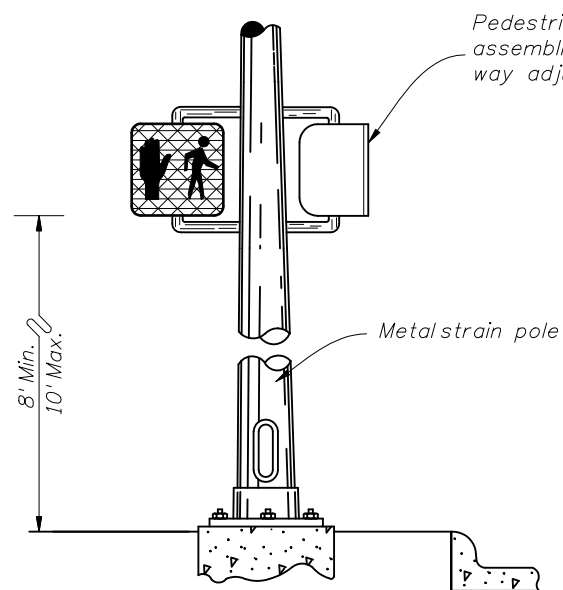
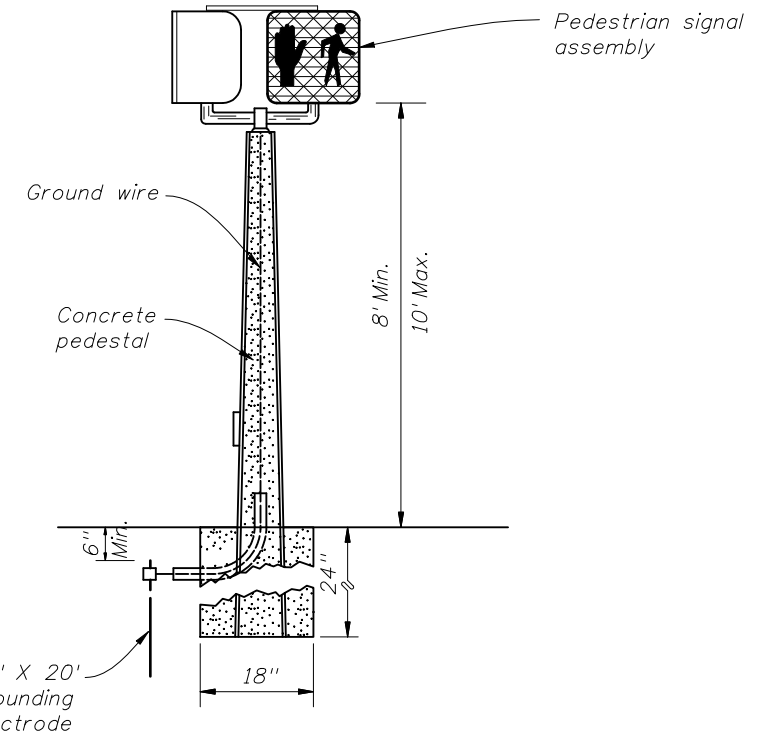

FIGURE C

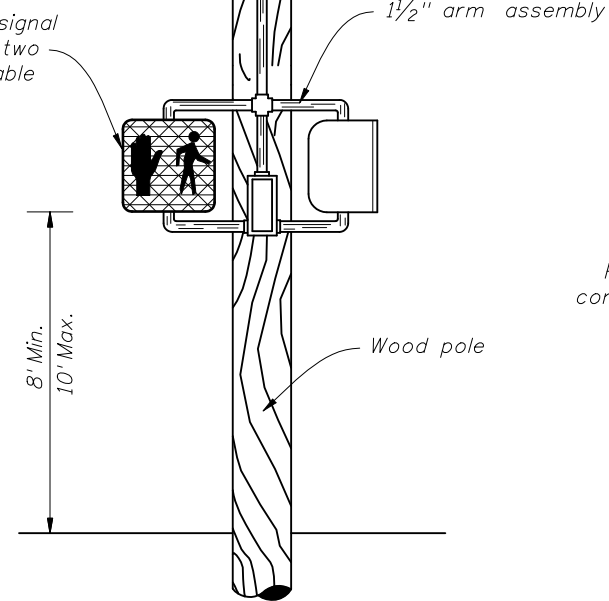

FIGURE D

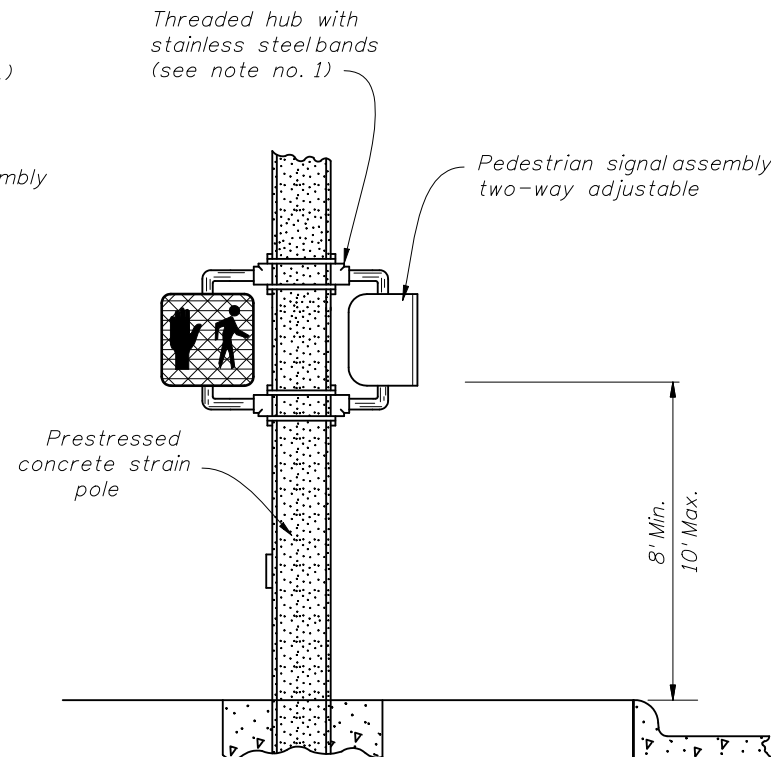

FIGURE E

Notes:

1. As an option, the contractor will be allowed to install pedestrian signals on concrete poles and pedestals with the use of lead anchors (two bolts same size per hub) in lieu of the stranded steel bands.
2. Holes drilled or punched in metal poles or pedestals shall be thoroughly reamed, cleaned of all burrs and covered with two (2) coats of zinc rich paint as specified in the standard specifications for road and bridge, construction. Grommets or bushings shall be installed in holes.
3. Meet all grounding requirements of Section 620 of the Standard Specifications.



2008 FDOT Design Standards

**PEDESTRIAN CONTROL SIGNAL
INSTALLATION DETAILS**

| | |
|---------------|-----------|
| Last Revision | Sheet No. |
| 07/01/04 | 1 of 1 |
| Index No. | |
| 17764 | |