

FOR USE IN AREAS NOT EXPOSED TO VEHICULAR TRAFFIC AND UNDER DRIVEWAYS

FIGURE A

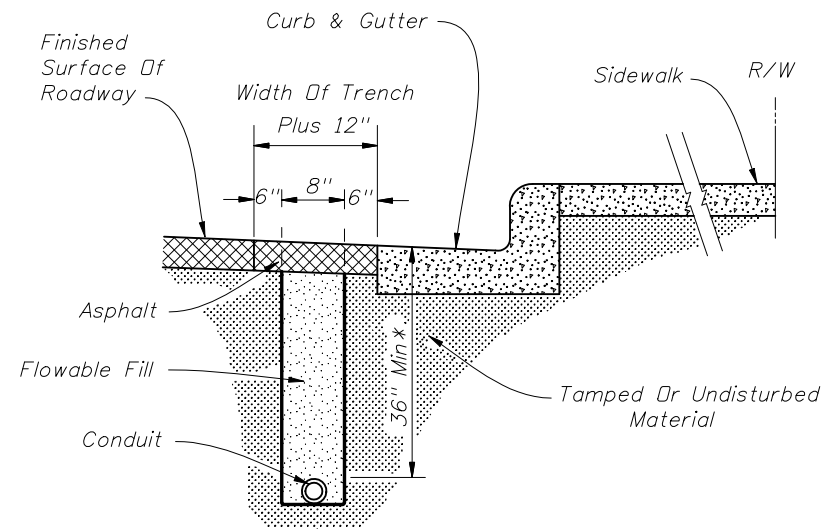

FOR USE IN ASPHALT ROADWAY ADJACENT TO GUTTER WHEN PLACEMENT OUTSIDE OF THE PAVEMENT IS NOT FEASIBLE.

Note

1. Trench not to be open more than 250' at a time when construction area is subject to vehicular or pedestrian traffic.
2. Asphalt to be sawcut and removed to leave neat lines on both sides of the 12" pavement cut.
3. See note 3 Figure C.

FIGURE B

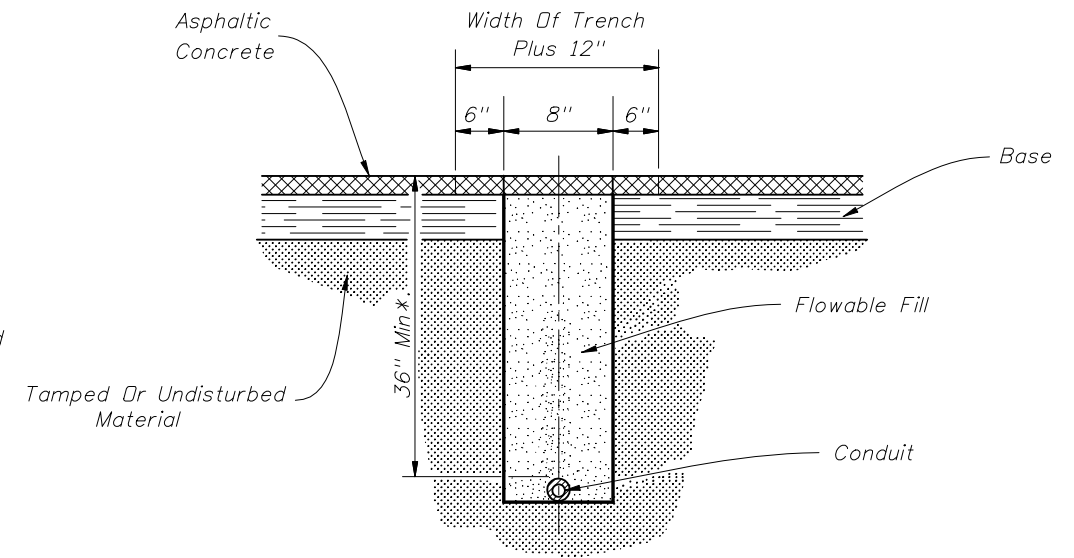

FOR USE IN INSTALLING CONDUIT UNDER EXISTING ASPHALT PAVEMENT NOT ADJACENT TO GUTTER WHEN JACKING IS NOT FEASIBLE

Note:

1. Rigid conduit must be used when jacking under existing pavement at 36" minimum depth.
2. Asphalt to be sawcut at the edges of the trench.
3. The removal and replacement of the additional pavement width (6") will not be required when the trench can be constructed without disturbing the asphalt surface on either side.

FIGURE C

*May be adjusted due to field conditions upon approval of project engineer.

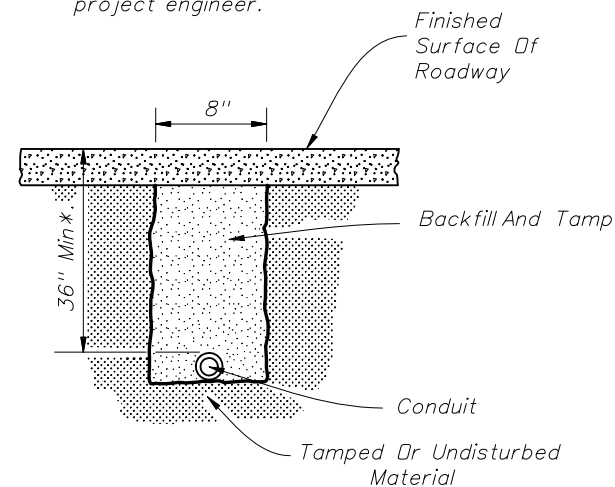

FOR USE INSTALLING CONDUIT UNDER A NEW ROADWAY PRIOR TO INSTALLATION OF CURBS, BASE AND PAVEMENT

FIGURE D

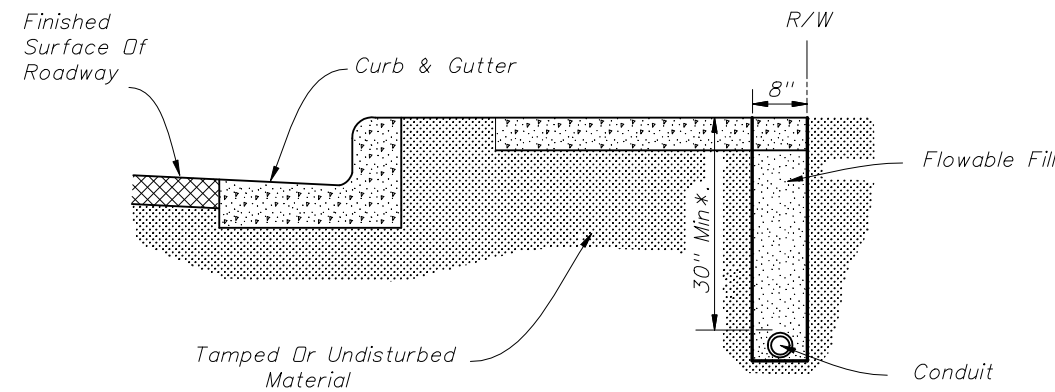

FOR USE IN INSTALLING CONDUIT UNDER SIDEWALK

Note:

1. Sidewalk patches to match existing joints.
2. Entire sidewalk slab must be replaced when specified in the plans.
3. Backfill and tamp with material from trench except at driveways. At driveways, backfill a length of trench within the driveway entirely with Flowable Fill.

FIGURE E

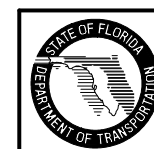

2008 FDOT Design Standards

CONDUIT INSTALLATION DETAILS

Last Revision	Sheet No.
07/01/00	1 of 2
Index No.	
17721	

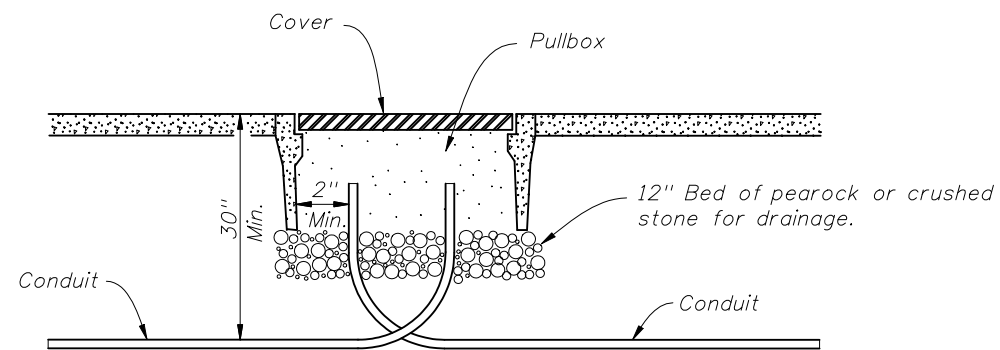

PULLBOX ENTRY OF CONDUIT UNDER SIDEWALKS

FIGURE A

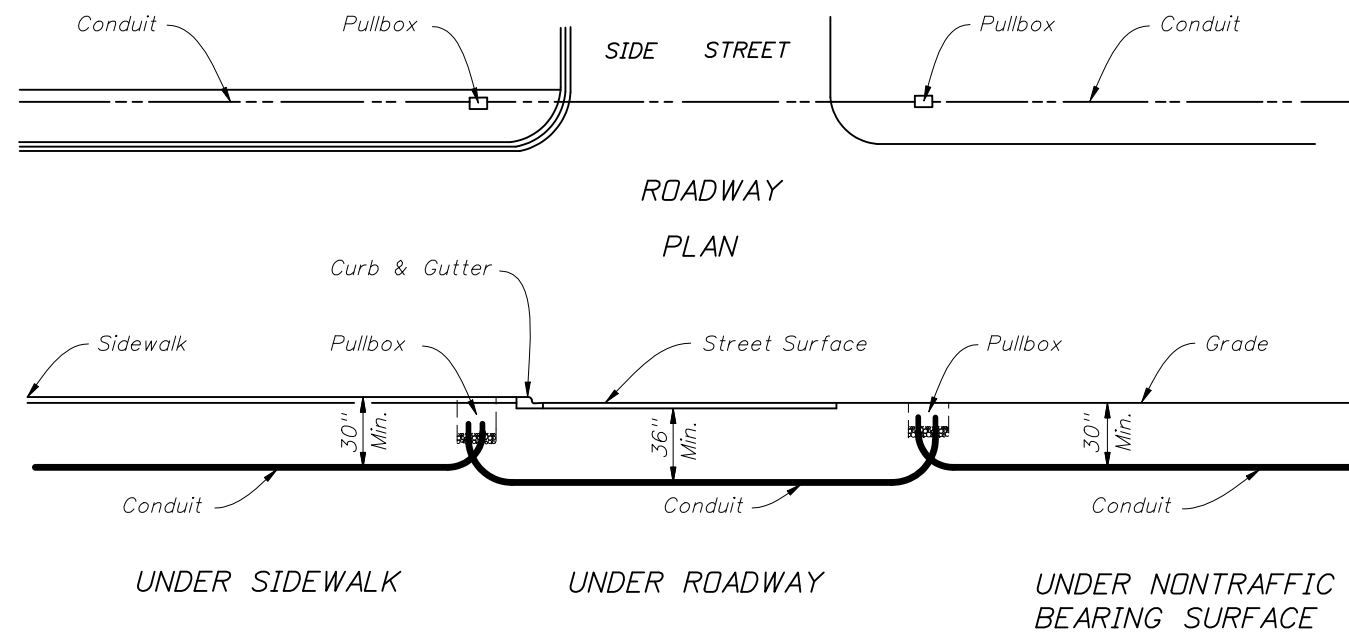

SECTION

FIGURE B

Note:
Ends of conduit shall be sealed in accordance with Section 630 of the Standard Specifications for Road and Bridge Construction.

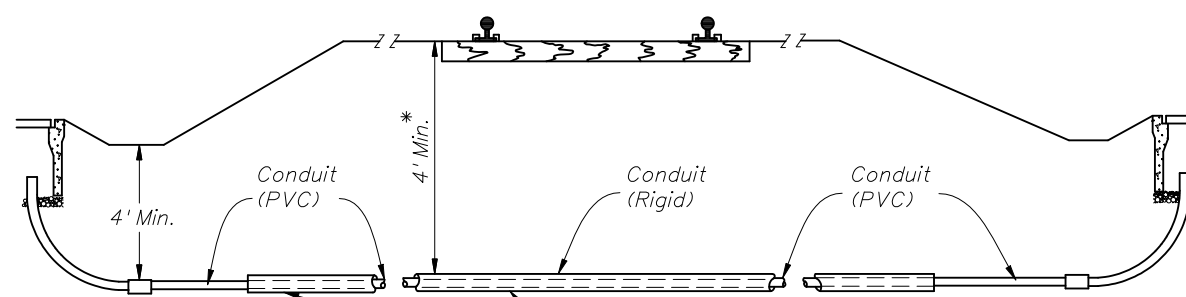

* Note
Conduit depth to be at RR requirement but not less 4'.

FOR USE UNDER RAILROADS

FIGURE C

Note:
One run of conduit (between pullboxes) shall not contain more than 360° of bend including pullbox bends.



2008 FDOT Design Standards

CONDUIT INSTALLATION DETAILS

Last Revision	Sheet No.
07/01/00	2 of 2
Index No.	
17721	