

BASE PLATE & BOLT PATTERN

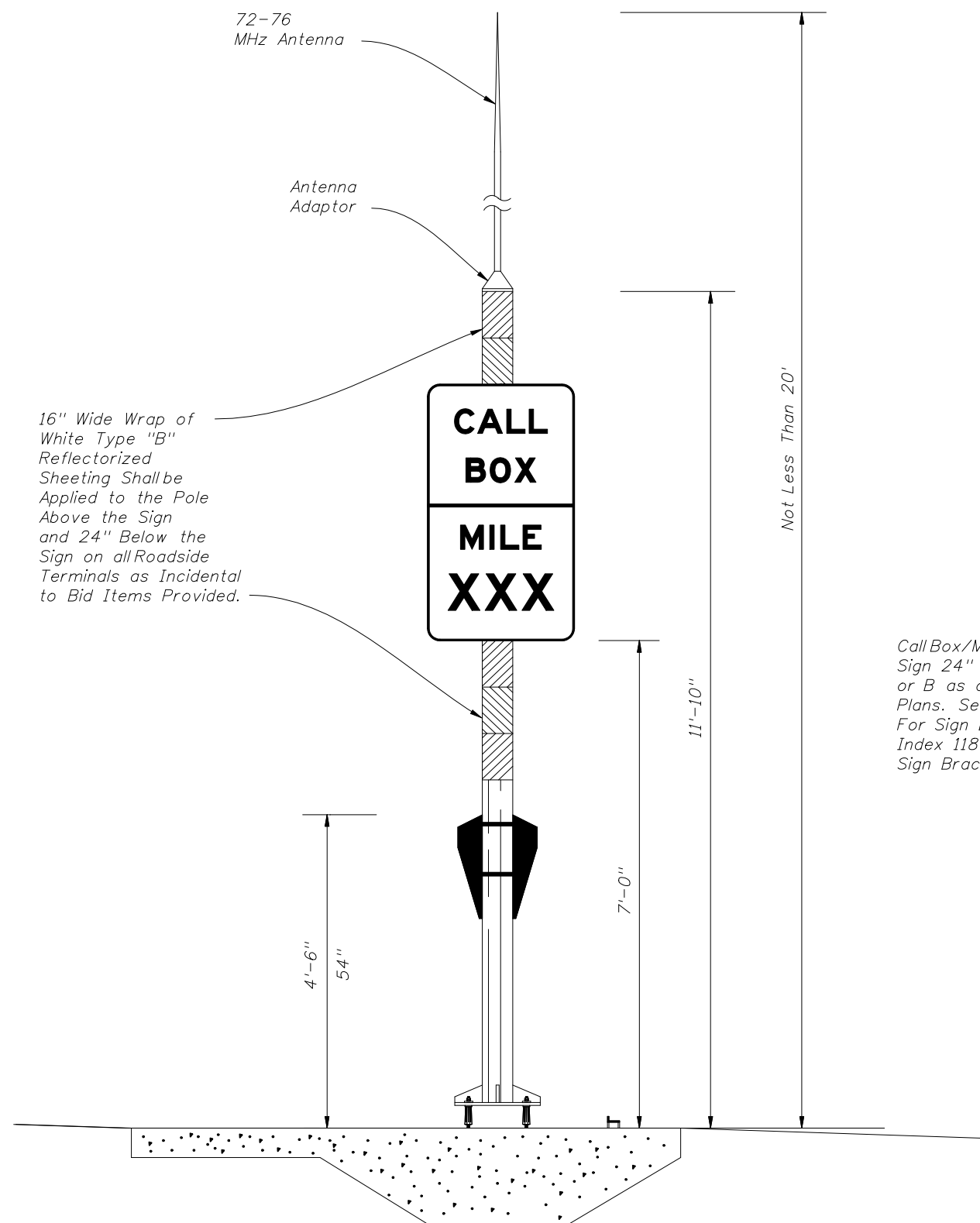

See Sheet 3 of 3 for
Concrete Pad Details.

TYPICAL MOTORIST AID CALL BOX TERMINAL

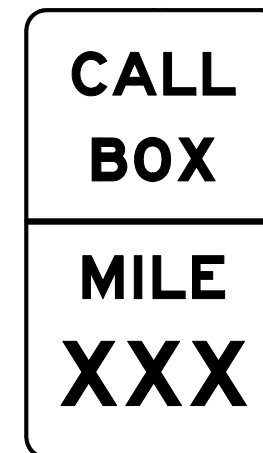

FTP-63-06
SIGN A

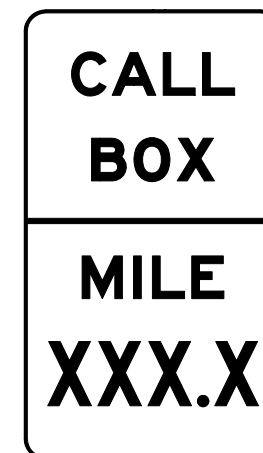

FTP-64-06
SIGN B

Call Box/Mile Marker
Sign 24" X 42". Sign A
or B as called for in
Plans. See Index 17355
For Sign Details and
Index 11860 for Type **
Sign Bracket Details.



2008 FDOT Design Standards

MOTORIST AID CALL BOX

Last Revision 07/01/04	Sheet No. 1 of 3
Index No. 17600	

EXISTING PAVEMENT INSTALLATION

Remove existing pavement minimum 1" depth throughout transition and maneuvering area, replace with misc asphalt.

NEW CONSTRUCTION

Hand work final shoulder pavement lift to plan dimensions.

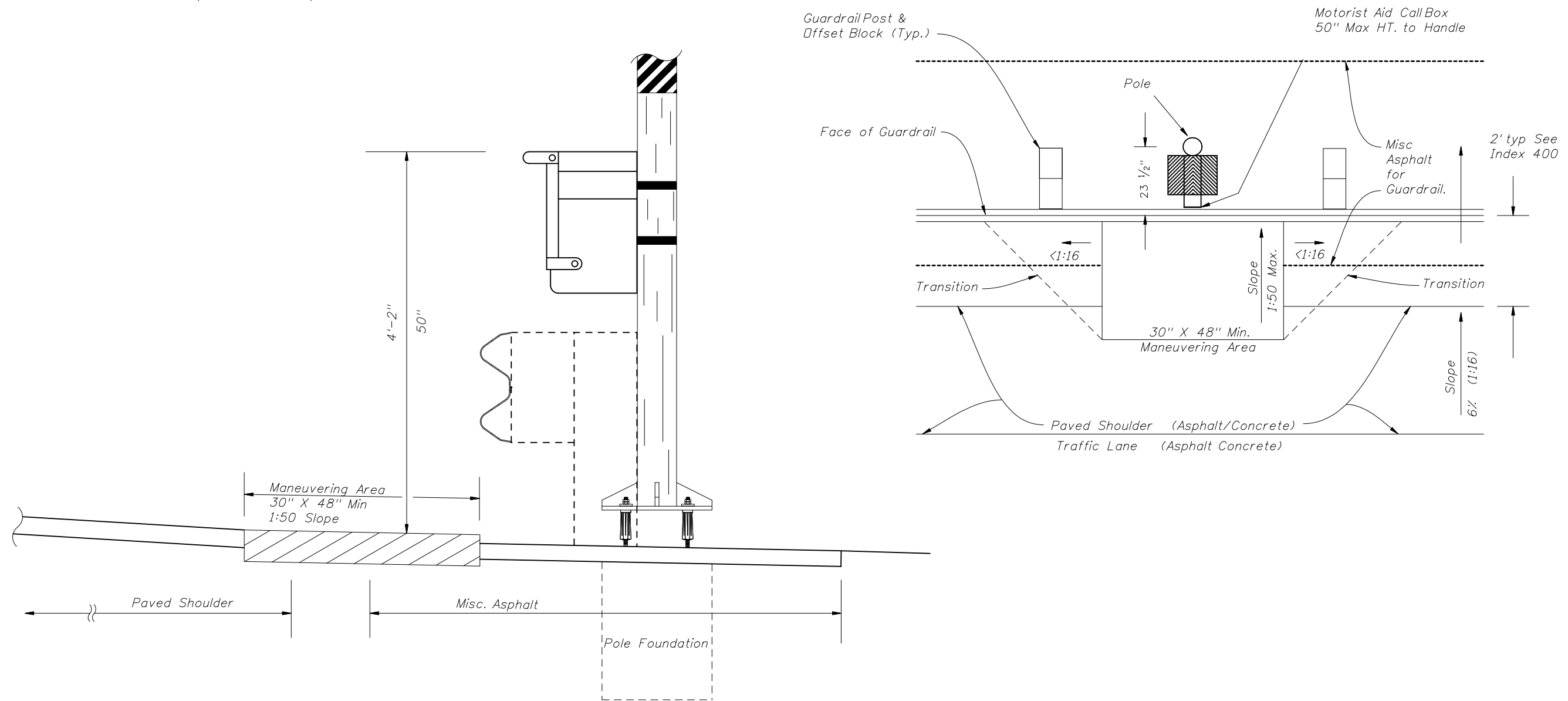

CALL BOX BEHIND GUARDRAIL



2008 FDOT Design Standards

MOTORIST AID CALL BOX

Last Revision	Sheet No.
07/01/05	2 of 3
Index No.	
17600	

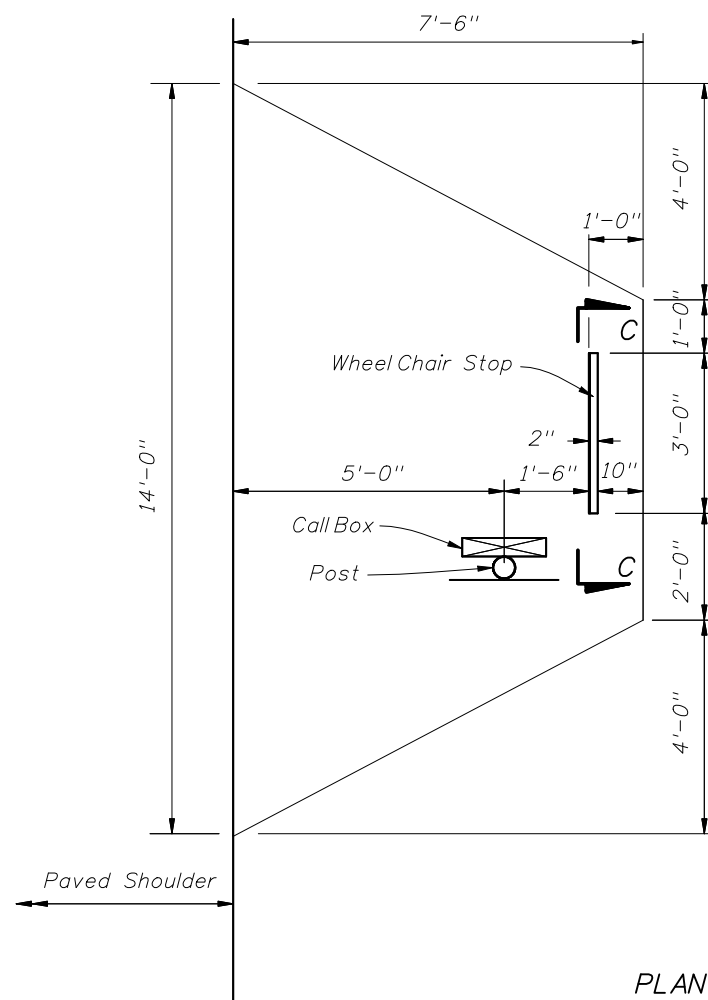

PLAN

Call Box Attachment To Slab
As Per Manufacturer's Recommendation.

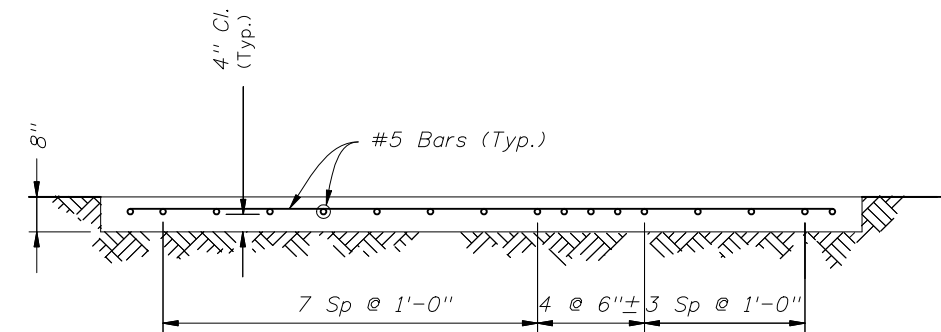
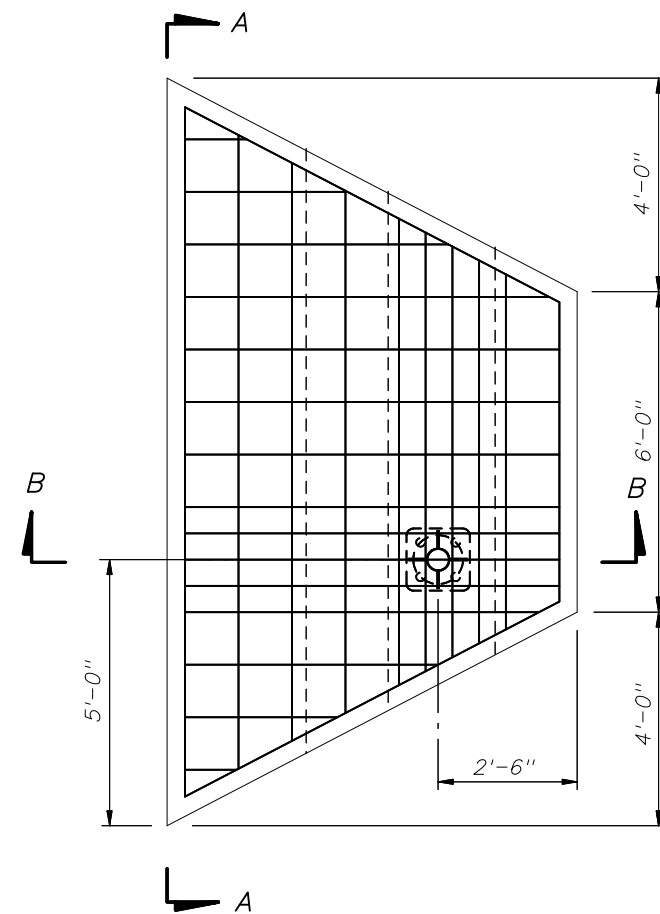

SECTION A-A

MOTORIST AID CALL BOX CONCRETE PAD QUANTITIES

Concrete : 3.5 c.y. (each)
Reinforcing Steel: 243 lb (each)

GENERAL NOTES

1. Design Specifications: AASHTO Standard Specifications For Highway Bridges (Current Edition and approved revisions thereto).
2. Concrete: Concrete strength shall be Class II ($f'c=3,400$ psi).
3. Reinforcing Steel: Reinforcing Steel shall conform to ASTM A615, Grade 60.
4. Payment : Motorist Aid Call Box Concrete Pads shall be paid for under the contract unit price for Class II Concrete (Miscellaneous), c.y. and shall include all labor, materials, and installation of embedded breakaway device sleeves, and miscellaneous galvanized steel for wheelchair stop and attachments.
5. Breakaway Device shall be paid for under Call Box Assembly.

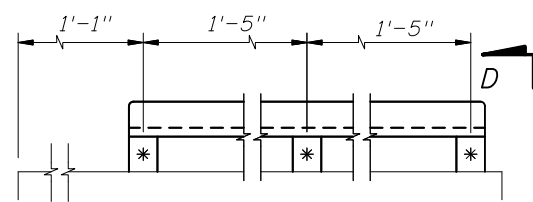

SECTION C-C

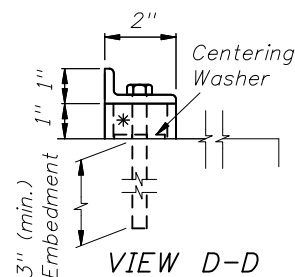

* 1 1/2" ϕ x 1" High
Galvanized Steel Pipe Spacer

2" x 1" x 1/4" Galv. Angle And
3-3/8" ϕ x 5" Galvanized Steel Expansion
Anchor Bolt With 3" Min. Embedment

WHEEL CHAIR STOP DETAIL

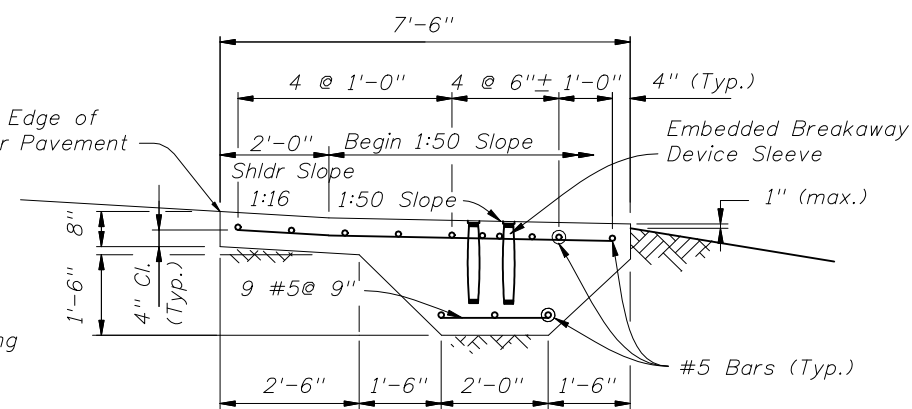

SECTION B-B



2008 FDOT Design Standards

MOTORIST AID CALL BOX

Last Revision	Sheet No.
07/01/05	3 of 3
Index No.	
17600	