

Foundations apply only to slopes of 1:4 or flatter.

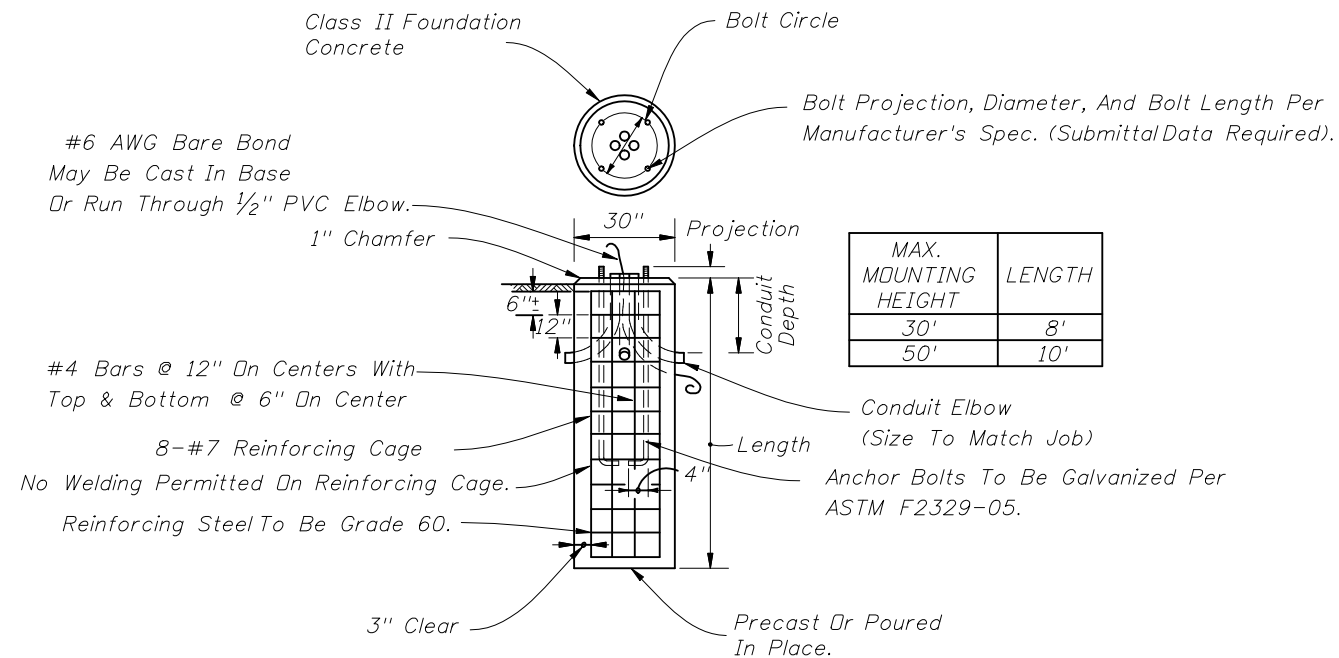

METAL POLE CONCRETE FOUNDATION DETAIL

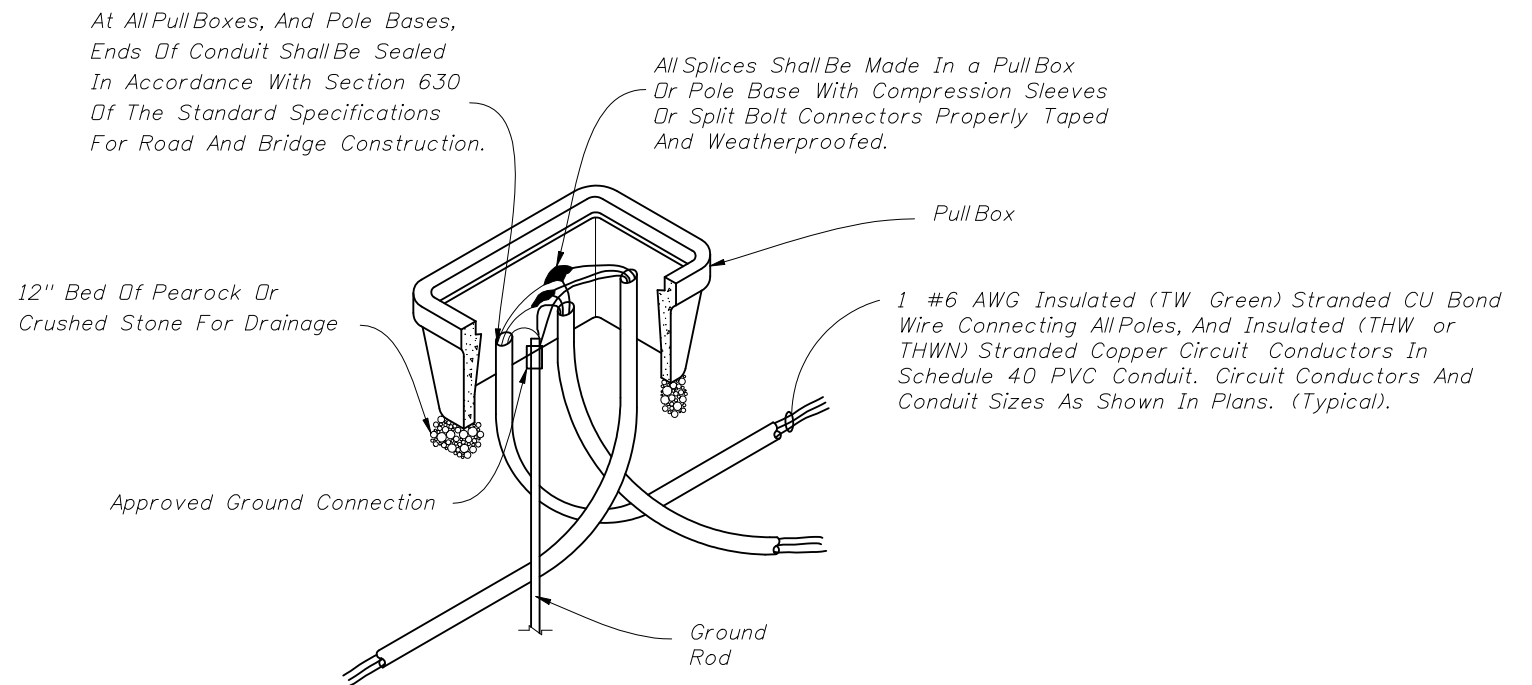

PULL BOX WIRING DETAIL

NOTE

Foundation design based upon the following conservative soil criteria which covers the great majority of soil types found in Florida:

- Classification = Cohesionless (Fine Sand)
- Friction Angle = 30 Degrees (30°)
- Unit Weight = 50 lbs./cu. ft. (assumed saturated)

Only in cases where the Designer considers the soil types at the specific site location to be of lesser strength properties should an analysis be required. Auger borings, SPT borings or CPT soundings may be utilized as needed to verify the assumed soil properties, and at relatively uniform sites, a single boring or sounding may cover several foundations. Furthermore, borings in the area that were performed for other purposes may be used to confirm the assumed soil properties. In any event, only the soil identification is required.



2008 FDOT Design Standards

ROADWAY LIGHTING DETAILS

Last Revision	Sheet No.
07/01/07	1 of 1
Index No.	
17503	