

**CANTILEVER SIGN STRUCTURE NOTES**

- 1) Design according to FDDT Structures Manual. Alternate Designs are not allowed.
- 2) Submit shop drawings for all work. Include:
  - a. Field verification of all upright heights.
  - b. Foundation elevations necessary to insure minimum vertical clearances as per traffic plans.
  - c. Anchor bolt orientation with respect to centerline of truss and the direction of traffic.
  - d. Show chord splices a minimum distance of 2 truss panel lengths apart. "SD" Panel from upright is the closet panel in which a chord splice may be used. See plans for Cantilever Sign Structure Data Table. Upright splices are not allowed.
- 3) Shop Fabrication, Assembly, Handling and Shipping:
  - a. Do not begin fabrication before receiving shop drawing approval.
  - b. Welding: Conform to American Welding Society Structural Welding Code (Steel) ANSI/AWS D1.1 (current edition).
  - c. Shop assemble the entire structure after galvanizing and prior to shipment.
  - d. If necessary, disassemble and secure components for shipment.
- 4) Sign Structure Materials:
  - a. Upright and Chords (Steel Pipe): API -5L-X42 (42 ksi yield) or ASTM A500, Grade B.
  - b. Steel Angles: ASTM A 709, Grade 36.
  - c. Steel Plates: ASTM A 709, Grade 36.
  - d. Weld Metal: E70XX.
  - e. Bolts: ASTM A307 or ASTM A325 Type 1, (snug tight) with single, self-locking nuts or regular nuts with a galvanized, locking TRW "Palnut."
  - f. Anchor Bolts: ASTM F1554, Grade 55 with ASTM A563 Grade A heavy-hex double nuts.
  - g. Install all nuts per manufacturer's instructions.
  - h. Bolt hole diameters: equal to the bolt diameter plus 1/16".
  - i. Anchor bolt hole diameters: equal to the bolt diameter plus 1/2".
- 5) Galvanization: Nuts, bolts and washers: ASTM F2329. Other steel items: ASTM A123
- 6) Sign Panels: Aluminum. See Elevation drawing for sizes and locations.
- 7) Foundation Materials:
  - a. Reinforcing Steel: ASTM A615, Grade 60.
  - b. Concrete: Class IV, minimum 5.5 ksi compressive strength at 28-days for all environmental classifications.
  - c. Grout: Minimum 5.0 ksi compressive strength at 28-days. Conform to Specification Section 934 using procedures outlined in Section 649-6.
- 8) Construct the Sign Structure foundation in accordance with FDDT Specification Section 455.
- 9) If a grout pad is not installed, place wire cloth screen vertically between the base plate and top of foundation, wrap horizontally around the base plate with a 3" min. lap. Use standard grade, plain weave, 2x2 mesh, galvanized steel wire-cloth with 0.063" dia. wire. Attach the screen to the base plate with stainless steel self-tapping 1/4" screws with stainless steel washers spaced at 9" centers.
- 10) Prior to erection, record the as-built anchor locations and provide to the Engineer.
- 11) After placement of the upright and prior to installation of the truss, adjust the leveling nuts beneath the base plate to achieve the back rake shown on the Camber Diagram.
- 12) Place backfill above the footing prior to installation of the sign panels. Do not remove or reduce in height without prior approval of the Engineer.
- 13) Install sign panels as shown on the Elevation drawing.
- 14) Payment: All costs associated with the Sign Structure, Sign Panels, Foundation and all incidental items will be paid for under the Sign Structure pay item.

**ISOMETRIC VIEW**

\*NOTE: Contractor shall verify these Dimensions prior to Fabrication of Upright.

NOTE: See Plans for Cantilever Sign Structure Data Table.



2008 FDOT Design Standards

**CANTILEVER SIGN STRUCTURE**

Last Revision	Sheet No.
01/01/07	1 of 5
Index No.	
11310	

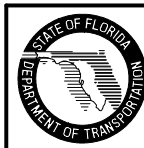
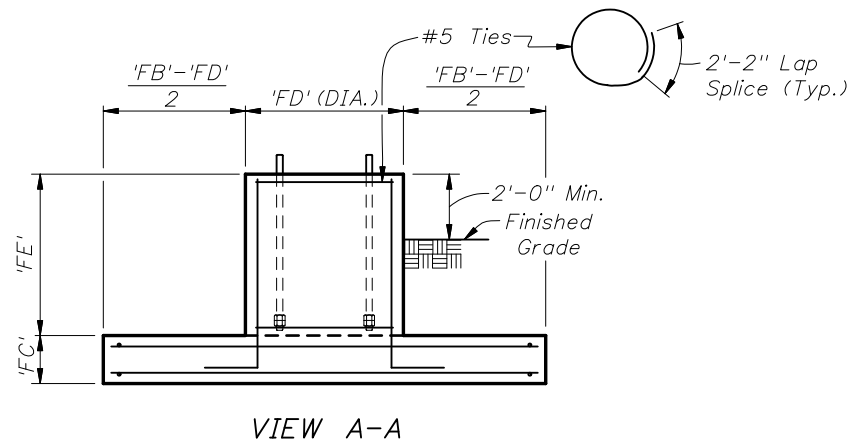
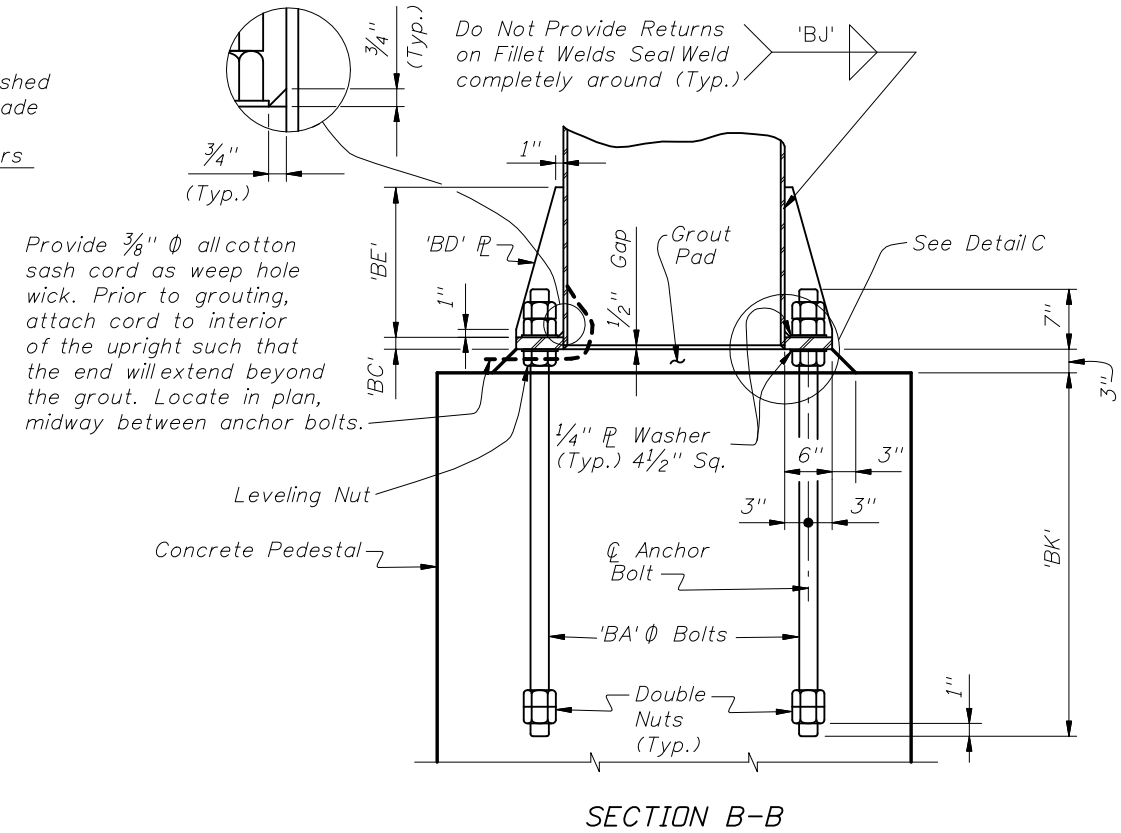
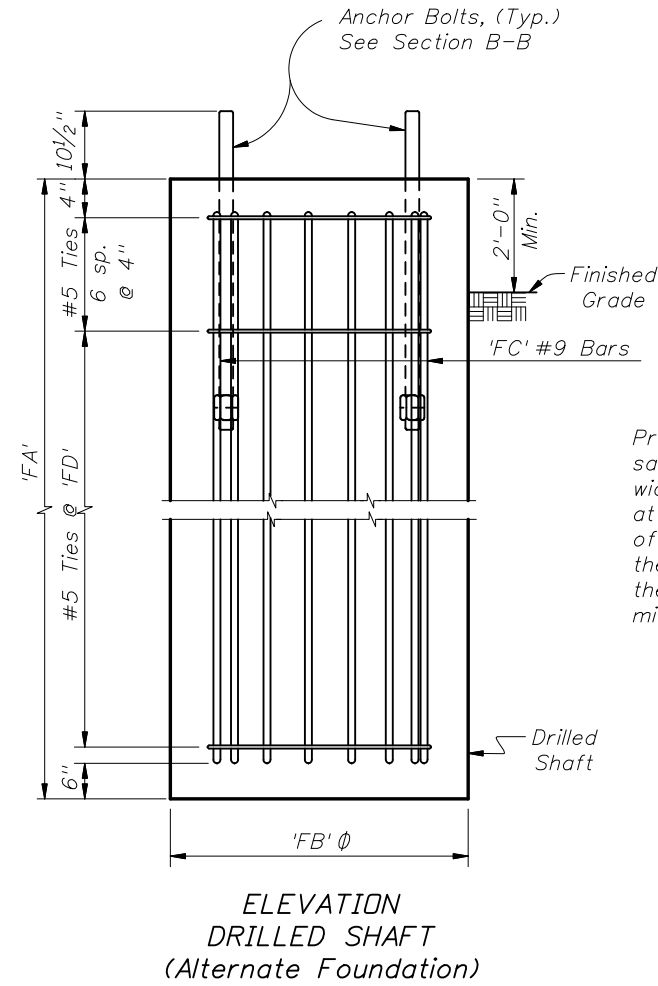
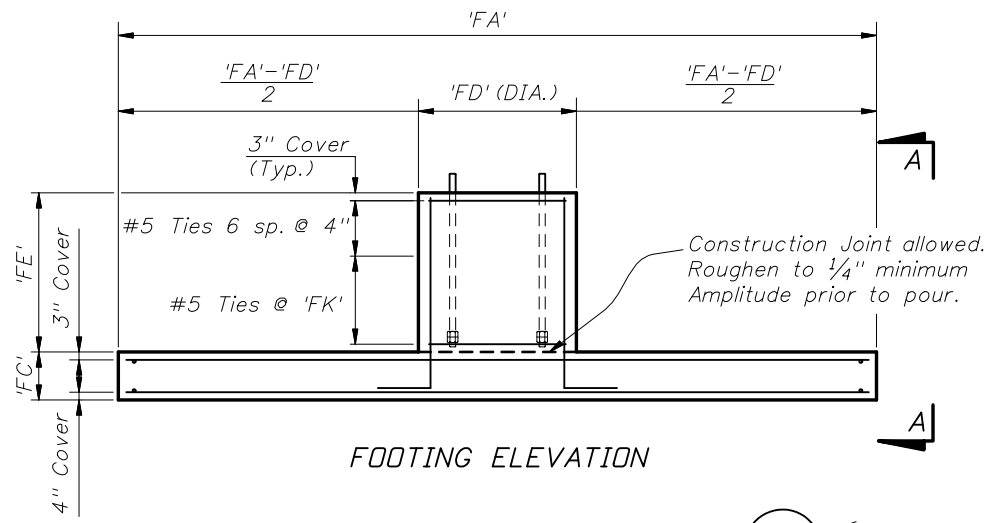
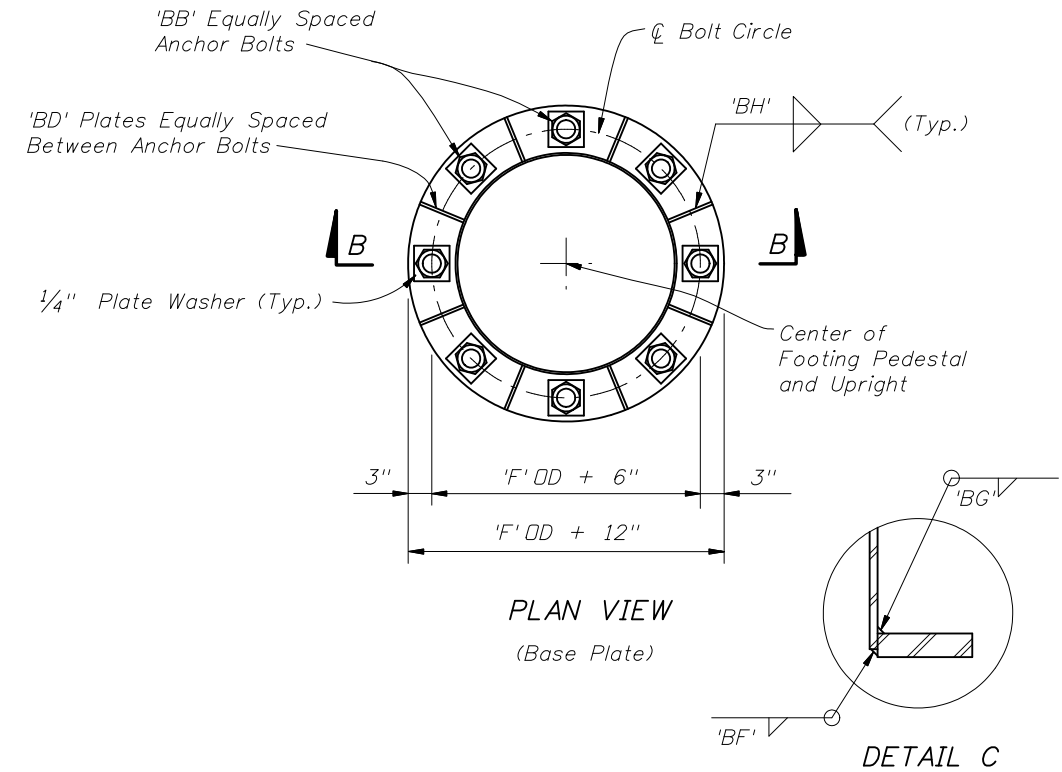
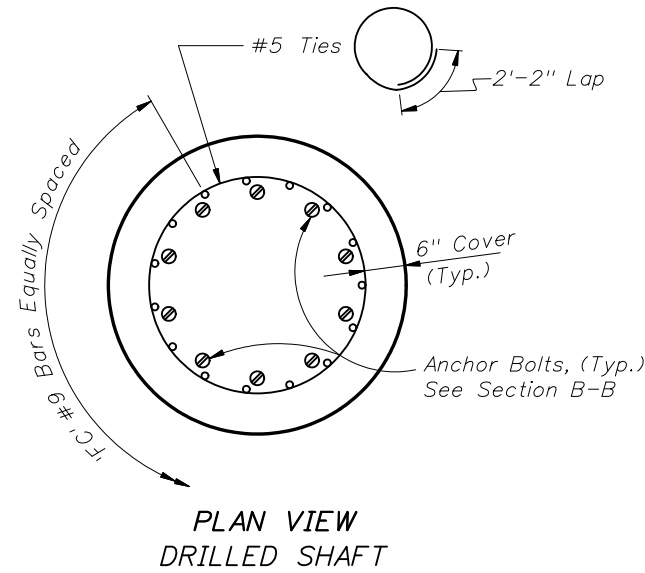
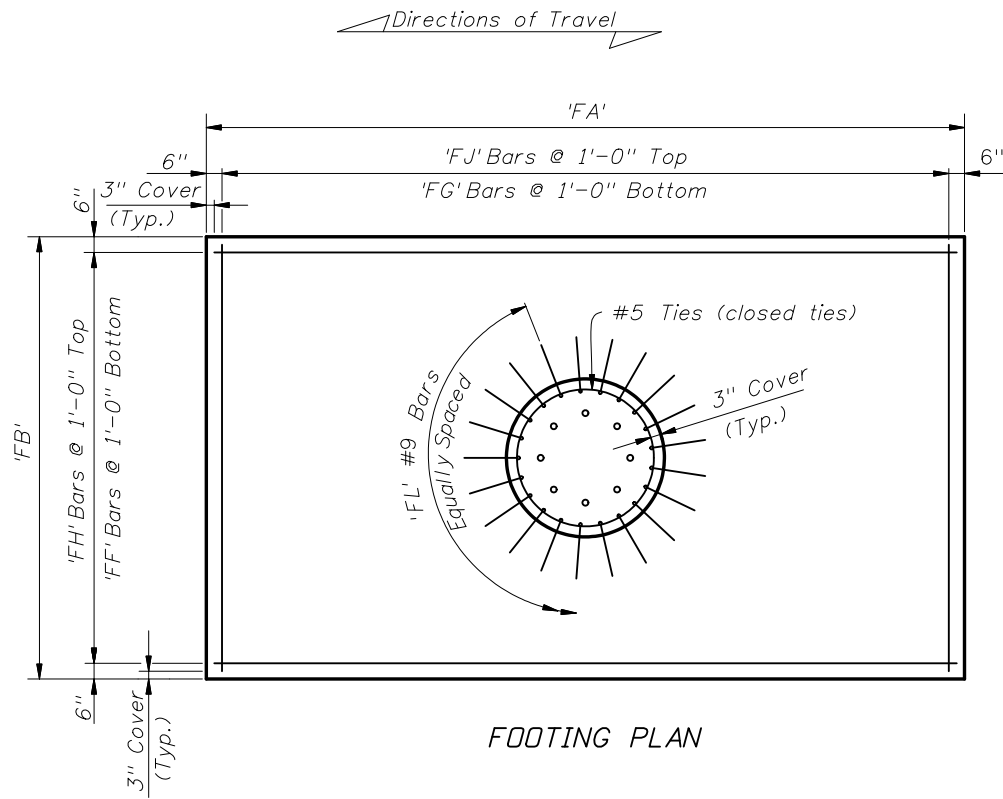

2008 FDOT Design Standards

CANTILEVER SIGN STRUCTURE

Last Revision	Sheet No.
01/01/07	2 of 5
Index No.	
11310	

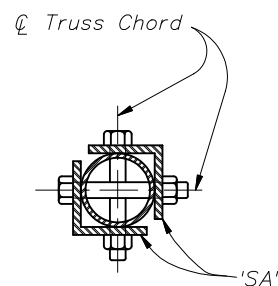

SECTION D-D

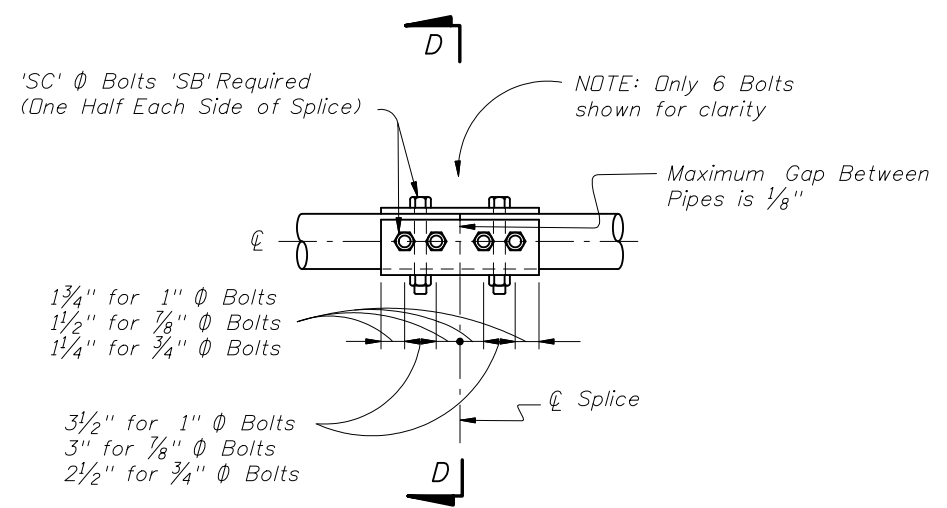

SPLICE CONNECTION DETAIL

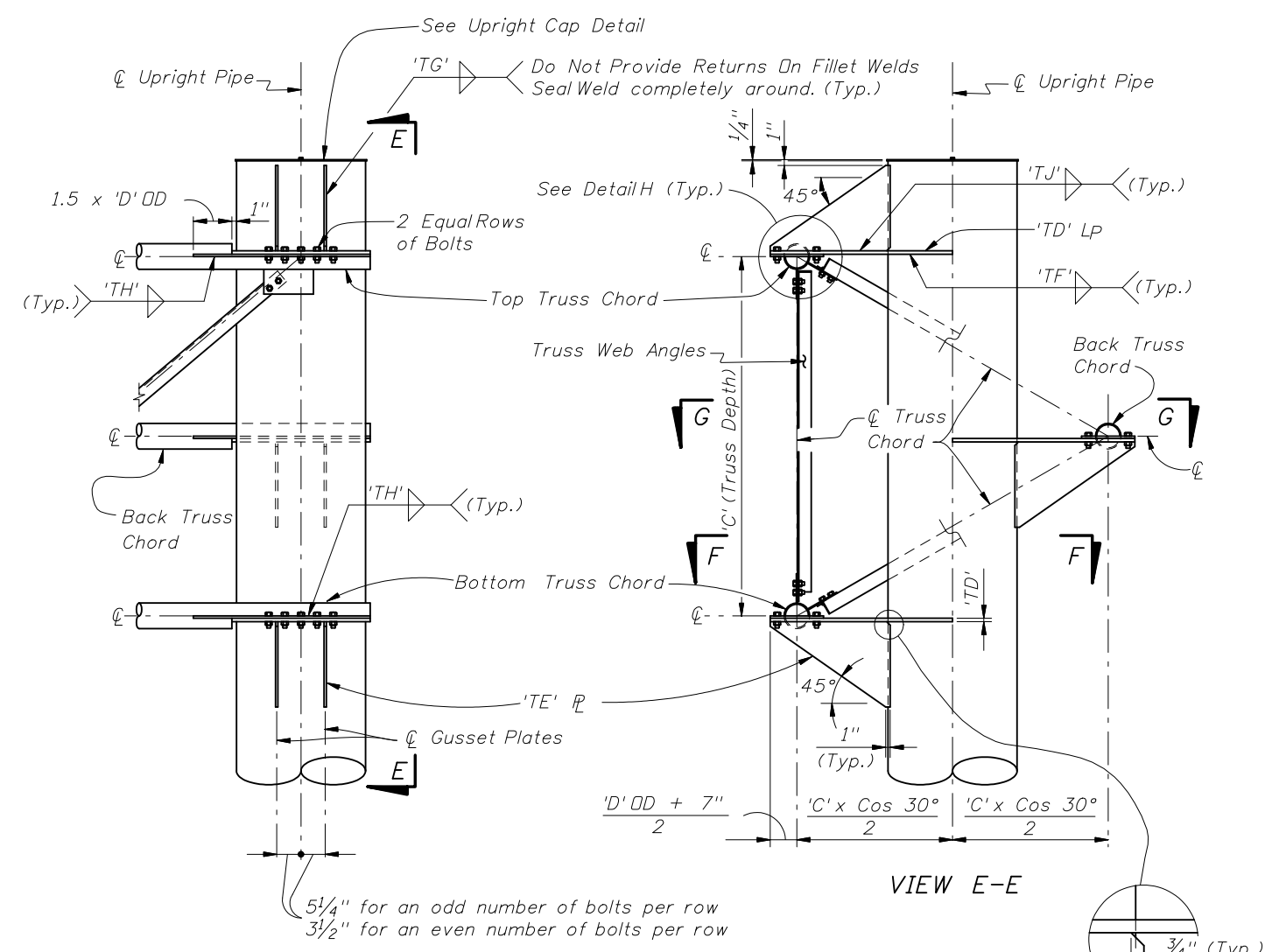

UPRIGHT-TRUSS CONNECTION DETAIL  
(Web Members from back Truss Chord omitted for clarity)

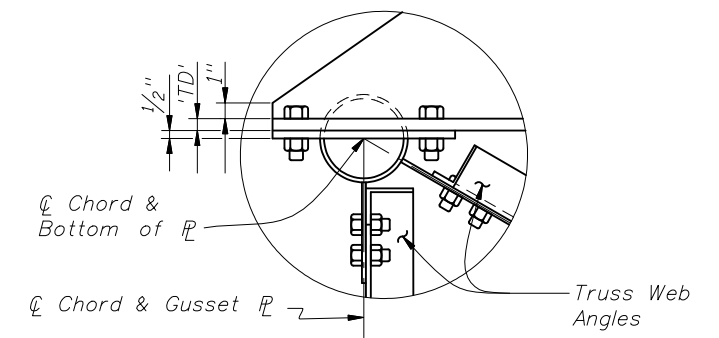

DETAIL H

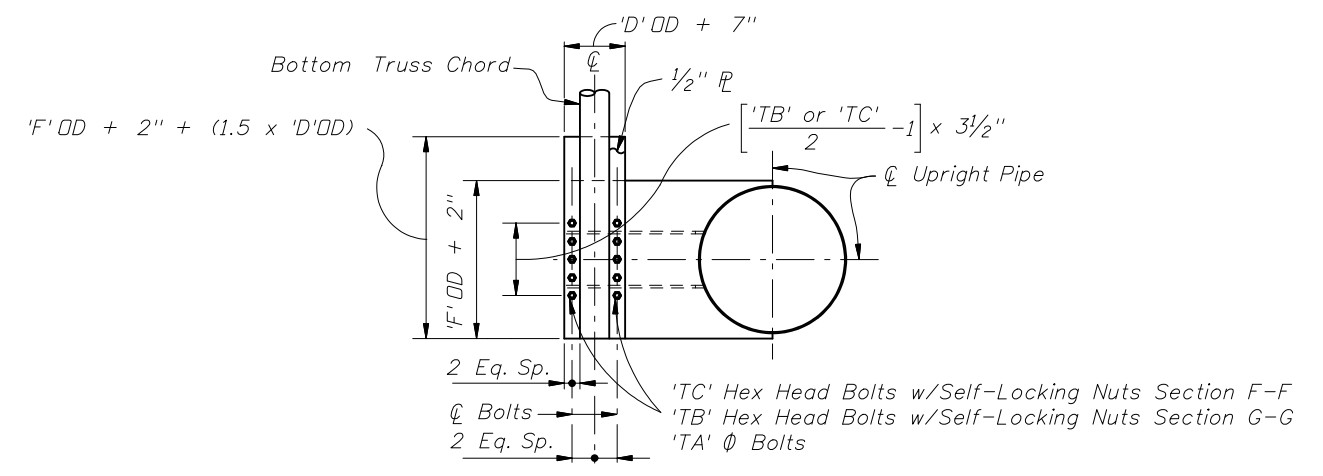

SECTION F-F, SECTION G-G SIMILAR  
(With Gusset Plate & Angles omitted for clarity)

NOTE:  
Abbreviation  
OD ~ Outside Diameter



2008 FDOT Design Standards

CANTILEVER SIGN STRUCTURE

Last Revision	Sheet No.
07/01/05	3 of 5
Index No.	
11310	

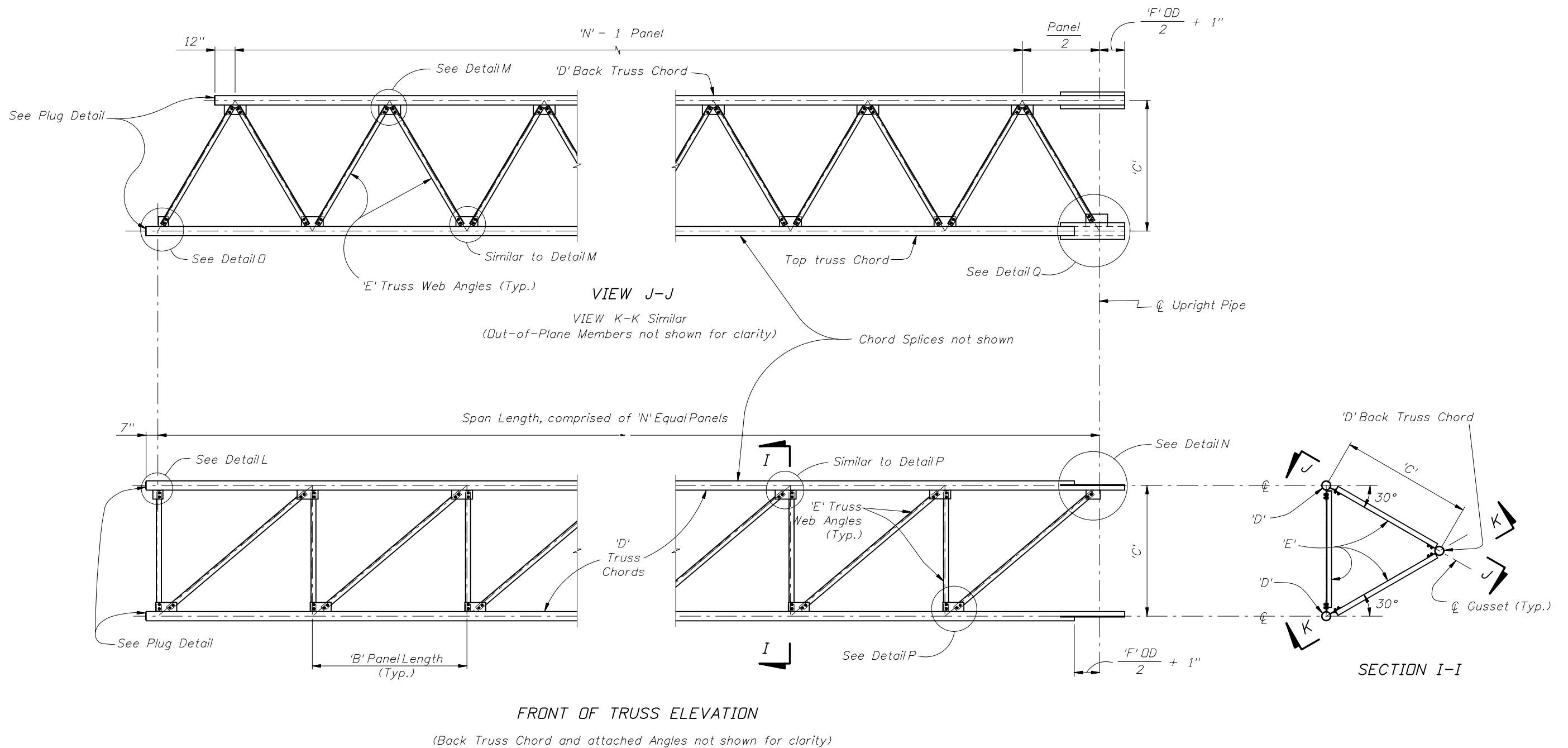

NOTE:  
Abbreviation  
OD ~ Outside Diameter

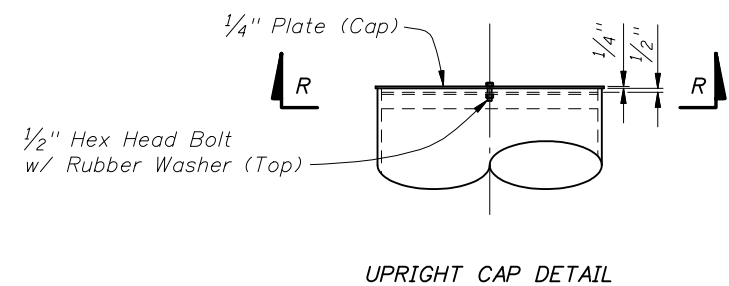
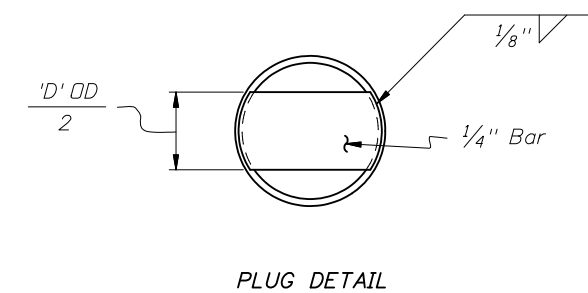
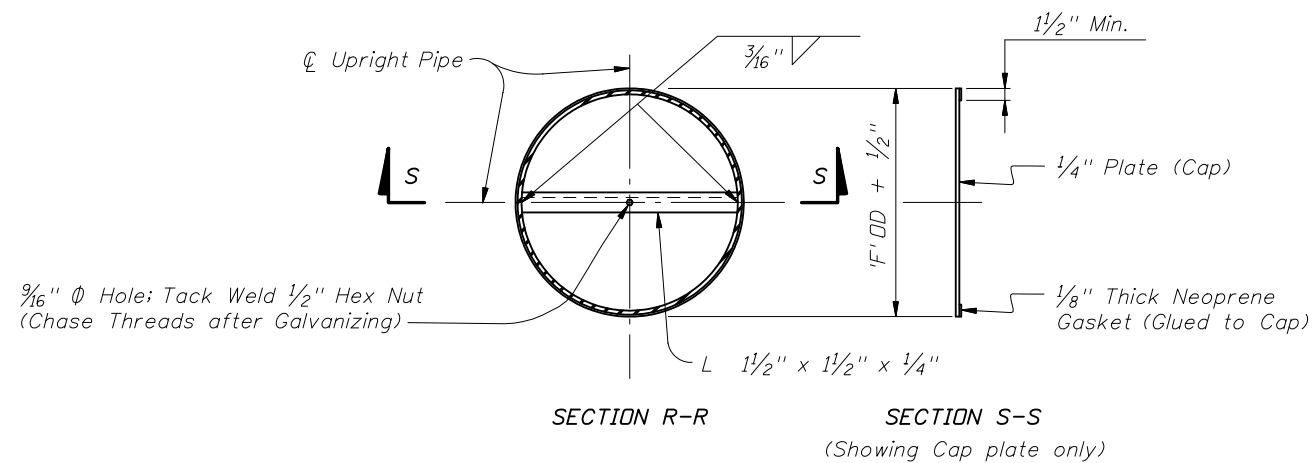
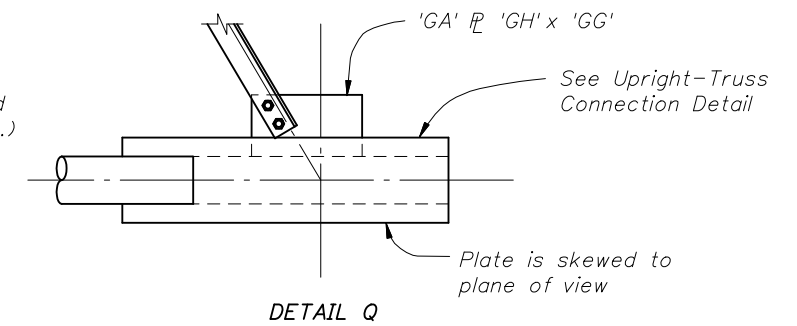
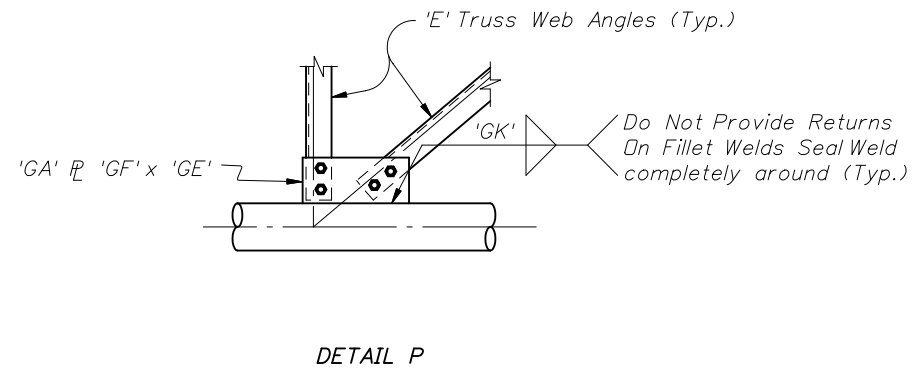
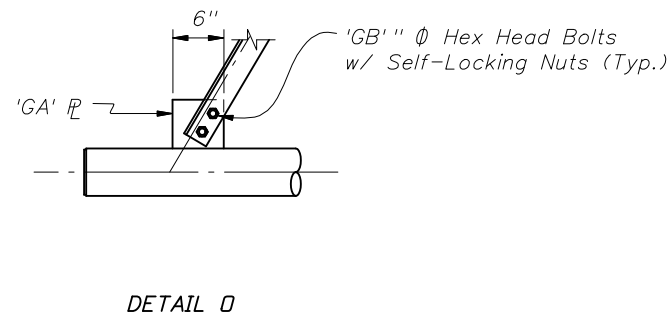
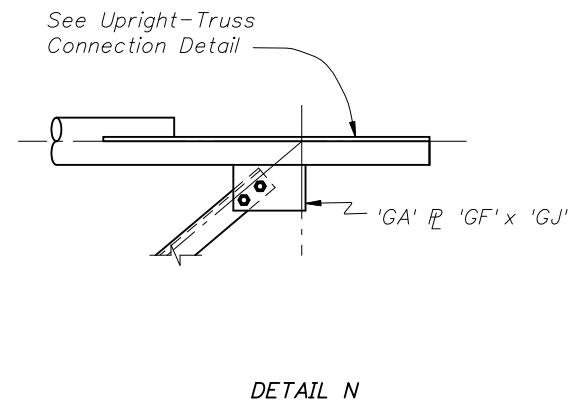
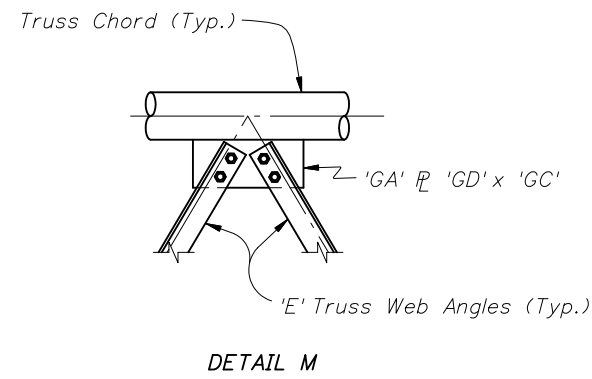
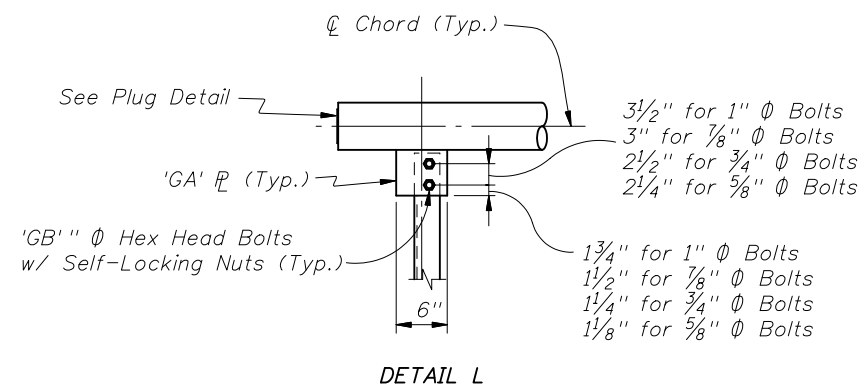

NOTE:  
Abbreviation  
OD ~ Outside Diameter



2008 FDOT Design Standards

CANTILEVER SIGN STRUCTURE

Last Revision	Sheet No.
07/01/05	5 of 5
Index No.	
11310	