

CROSS REFERENCE:  
 For Details "A", "B", "C", "D" and "E", see Sheet 2 of 2

**NOTES**

**GENERAL SPECIFICATIONS:**

The Florida Department of Transportation "Standard Specifications for Road and Bridge Construction".

**DESIGN SPECIFICATIONS:**

American Association of State Highway and Transportation Officials (AASHTO) "LRFD Bridge Design Specifications", current edition, including 75 year Design Life.

Florida Department of Transportation (FDOT) "Structures Design Guidelines", current edition.

State of Florida "Florida Building Code", current edition.

**DESIGN LIVE LOADS:**

Post and Base Plate: Equivalent point load = 200 lb. load + (50 lb/ft x Post Spacing (ft)) applied transversely at top rail connection.

Top and Bottom Rails: 50 lb/ft uniform load applied simultaneously vertically and transversely + 200 lb. concentrated point load applied at midspan in the directions for both maximum stress and deflection.

Pickets: Concentrated 200 lb load applied transversely over an area of 1.0 square foot.

**GEOMETRY:**

Clear Opening between Pickets: Shall reject the passage of a 4" diameter sphere below 42" height, and a 8" diameter sphere above 42" height.

Clear Opening under Bottom Rail: Shall reject the passage of a 2" diameter sphere.

Pedestrian Railing Height: 42" minimum.

Bicycle Railing Height: 54" minimum.

**DEFLECTION:**

Total combined deflection of the railing system including the resilient or neoprene pads, due to the top rail design live loads, shall not exceed 1/2" when measured at midspan of the top rail.

**APPLICABILITY NOTE TO DESIGNER:**

This Index is not approved for use on bridges. This railing is not applicable for shielding drop-off hazards for vehicular traffic.

This railing is applicable for all cases where a pedestrian or bicyclist drop-off hazard exceeds 2'-6" or when a drop-off hazard is less than 2'-6" and is required by design. Adequate foundation support shall be provided for anchorage and stability against overturning. For unusual site conditions a site specific railing is to be designed by the responsible engineer. The railing shown on this drawing requires a handrail for ramps steeper than a 5% grade to conform with the requirements of the Americans with Disabilities Act (ADA). Refer to FDOT Plans Preparation Manual (Volume I) Chapters 4 & 8, for the definition of vehicular, pedestrian and bicyclist "drop-off hazards".

**ALTERNATE DESIGN:**

Manufacturers seeking approval of proprietary railing systems for inclusion on the Qualified Products List as pre-approved alternate designs must submit application along with design documentation showing the proprietary railing system is designed to meet the design life, live loads, geometry and deflection requirements specified herein. All fixed joints are to be either welded or commercially designed fixed joint systems. Each field section of railing must be identified with a permanently affixed label with the manufacturer's name and the FDOT QPL approval number. Labels must be a maximum of 1/2" by 3" and located at the base of a post within the field section. Project specific shop drawings are required for QPL approved railings, see Shop Drawings note.

**PAYMENT:**

Railing shall be paid for per linear foot (Item No. 515-2-abb). Payment will be plan quantity measured as the length along the center line of the top rail, and includes rails, posts, pickets, rail splice assembly, base plates, anchor bolts, nuts, washers, resilient pads and all incidental materials and labor required to complete installation of the railing.

**RAILS, PICKETS & POSTS:**

Structural Tube and Pipe shall be in accordance with ASTM B221 or ASTM B429, Alloy 6061-T6. End Rail 90° Bends and corner bends with maximum 4'-0" post spacing, may be Alloy 6063-T6. Posts and End Rails shall be fabricated and installed plumb, ± 1" tolerance when measured at 3'-6" above the foundation. Pickets shall be fabricated parallel to the posts. Corners and changes in tangential longitudinal alignment, shall be made continuous with a 9" bend radius. For changes in tangential longitudinal alignment greater than 45°, posts shall be located at a maximum distance of 2'-0" each side of the corner and shall not be located at the corner apex. For curved longitudinal alignments the top and bottom rails shall be shop bent to match the alignment radius.

**BASE PLATES & POST CAPS:**

Base Plates and Post Cap plates shall be in accordance with ASTM B209, Alloy 6061-T6.

**SHIM PLATES:**

Shim Plates shall be aluminum in accordance with ASTM B209, Alloy 6061-T6. Shim plates shall be used for foundation height adjustments greater than 1/4" and localized irregularities greater than 1/8". Field trim shim plates when necessary to match the contours of the foundation. Beveled shim plates may be used in lieu of trimmed flat shim plates shown.

**COATINGS:**

The aluminum railing shall be mill finish unless otherwise noted in the Contract Documents.

All anchor bolts, nuts and washers shall be hot dip galvanized in accordance with Section 962-7 of the Specifications.

**ANCHOR BOLTS, NUTS AND WASHERS:**

Anchor bolts shall be in accordance with ASTM F1554 Grade 36. Headless anchor bolts shall be threaded full length. Expansion Anchors are not permitted. All anchor bolts shall have Single Self-Locking Hex Nuts. All nuts shall be in accordance with ASTM A563 or ASTM A194. Flat Washers shall be in accordance with ASTM F436 and Plate Washers (for long slotted holes only), shall be in accordance with ASTM A36 or ASTM A709 Grade 36. After the nuts have been snug tightened, the anchor bolt threads shall be distorted to prevent removal of the nuts. Distorted threads shall be coated with a galvanizing compound in accordance with the Specifications.

**RESILIENT AND NEOPRENE PADS:**

Resilient and Neoprene pads shall be in accordance with Specification Section 932 except that testing of the finished pads shall not be required. Neoprene pads shall be durometer hardness 60 or 70.

**JOINTS:**

All fixed joints are to be welded all around and ground smooth. Expansion joints shall be spaced at a maximum 35'-0". Field splices similar to the expansion joint detail may be approved by the Engineer to facilitate handling, but the railing must be continuous across a minimum of two posts. Only use the Continuity Field Splice (Detail "E") to make the railing continuous for unforeseen field adjustments.

**WELDING:**

All welding shall be in accordance with the American Welding Society Structural Welding Code (Aluminum) ANSI/AWS D1.2 (current edition). Filler metal shall be either ER5183, ER5356 or ER5556. Nondestructive testing of welds shall not be required.

**SHOP DRAWINGS:**

Complete details addressing project specific geometry (line & grade) showing post and expansion joint locations must be submitted by the Contractor for the Engineer's approval prior to fabrication of the railing. Shop drawings shall be in accordance with the Specifications.



2006 FDOT Design Standards

**ALUMINUM PEDESTRIAN/BICYCLE PICKET RAILING**

Last Revision	Sheet No.
07/01/05	1 of 2
Index No.	
860	

ANCHOR BOLT TABLE							
CASE	STRUCTURE TYPE	DIMENSIONS			ANCHOR LENGTH		ANCHOR SIZE
		"A" Edge Dist.	"B" Edge Dist.	"C" Embedment	C.I.P. Hex Head Bolt	Adhesive Anchor	
I	Unreinforced Concrete	6"	1'-2"	9"	10 1/2"	11"	3/4" $\Phi$
IIa	Reinforced Concrete	4"	4"	9"	10 1/2"	11"	3/4" $\Phi$
IIb	Gravity Wall Index No. 520	4 1/2"	3 1/2" @ top	1'-0"	1'-1 1/2"	1'-2"	3/4" $\Phi$

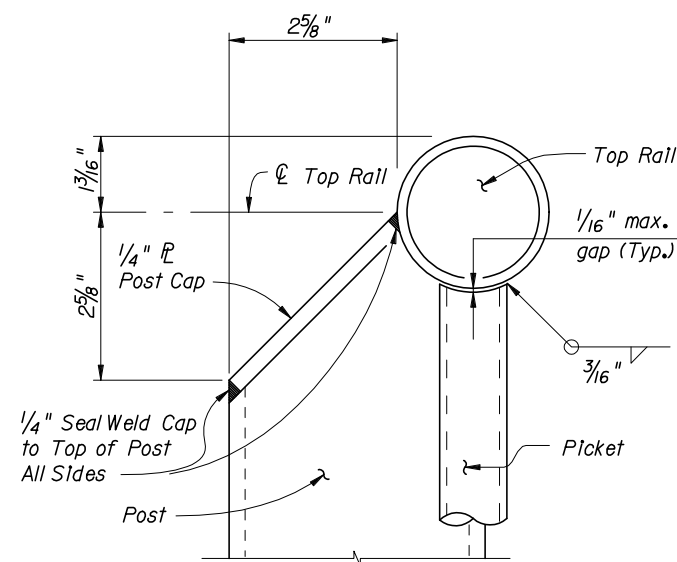

**DETAIL "B"**  
(Top of Picket Connection Shown,  
Bottom Connection Similar)

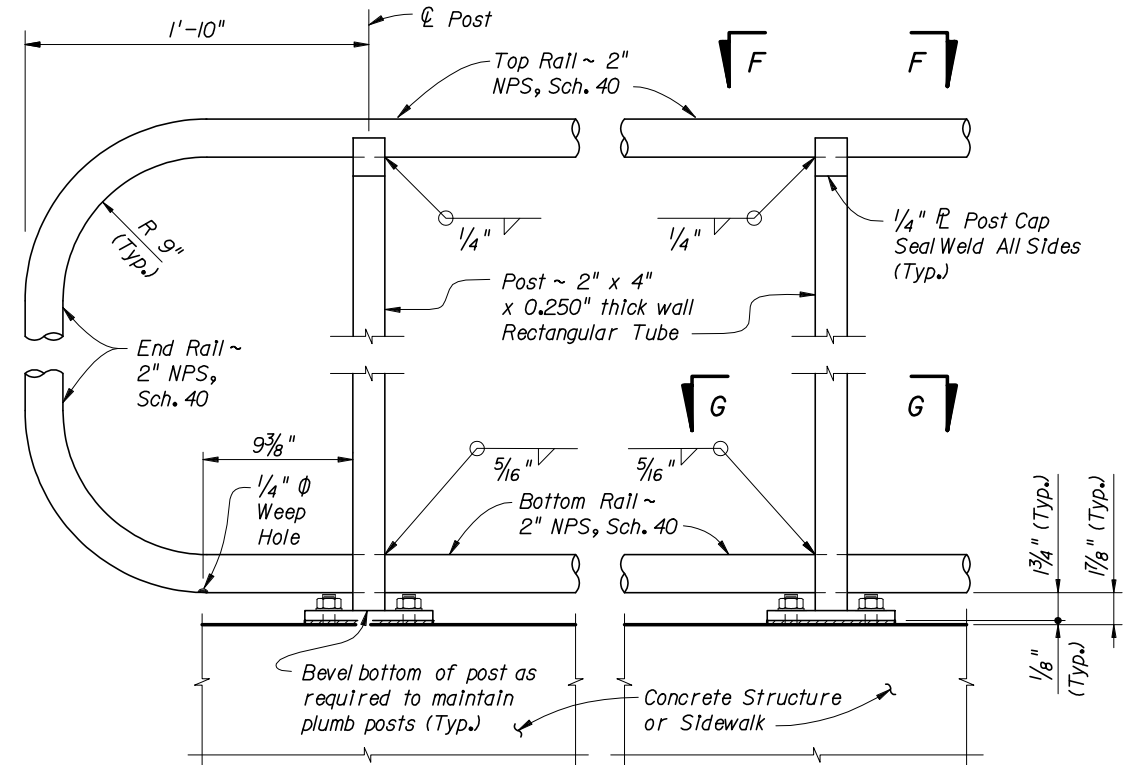

**DETAIL "C" - RAIL CONNECTIONS**  
(Showing Outside Face of Structure and Railing  
Pickets Not Shown for Clarity)

RAILING MEMBER DIMENSIONS			
MEMBER	DESIGNATION	OUTSIDE DIMENSION	WALL THICKNESS
Posts	2" x 4" Rectangular Tube (with or without radius edges)	2.00" x 4.00"	0.250"
Rails	2" NPS (Sch. 40)	2.375"	0.154"
Joint/Splice Sleeves	1 1/2" NPS (Sch. 40)	1.900"	0.145"
Pickets	3/4" NPS (Sch. 40)	1.050"	0.113"

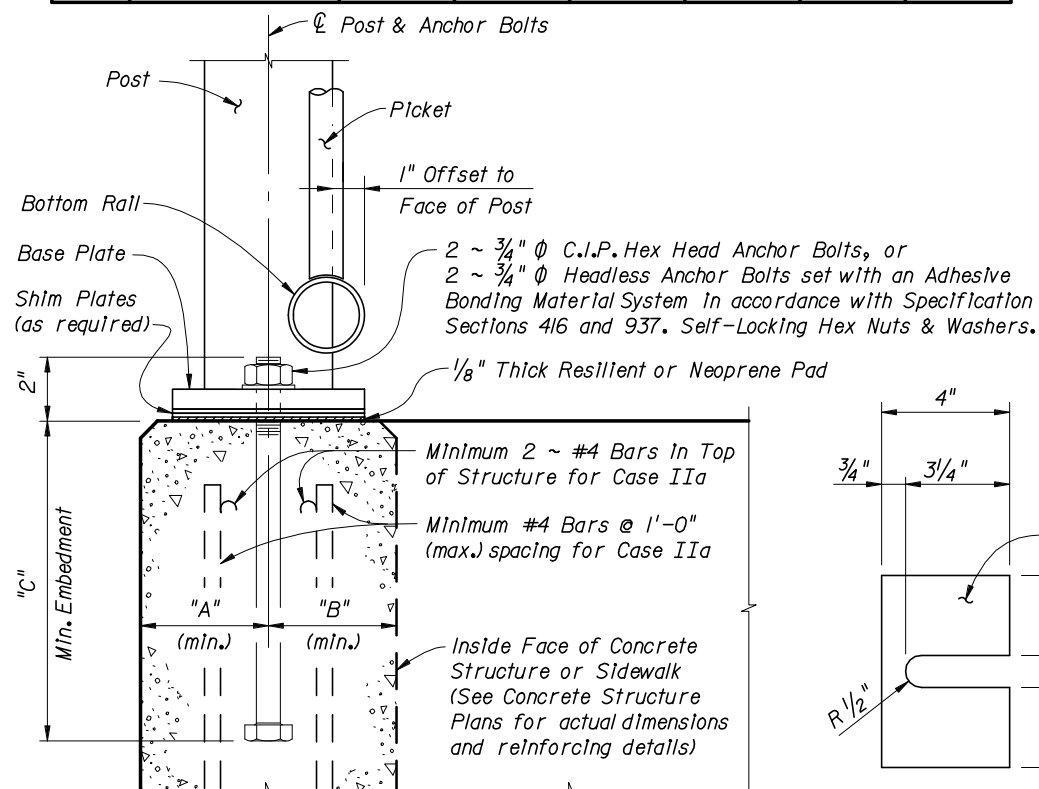

**DETAIL "A"**  
(Cast-In-Place Anchor Bolts Shown,  
Adhesive Anchors Similar)

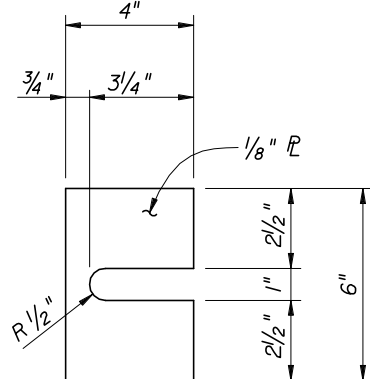

**SHIM PLATE DETAIL**

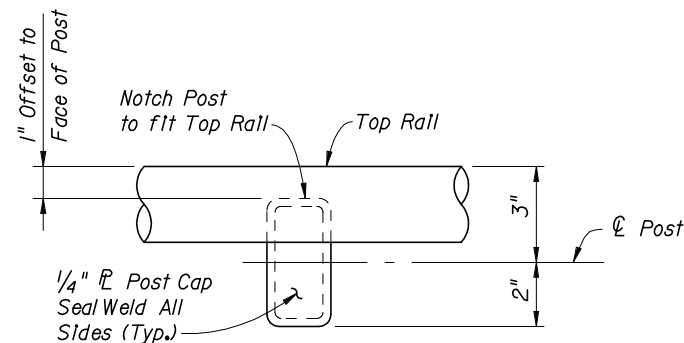

**VIEW F-F  
TOP RAIL CONNECTION**  
(Base Plate Not Shown for Clarity)

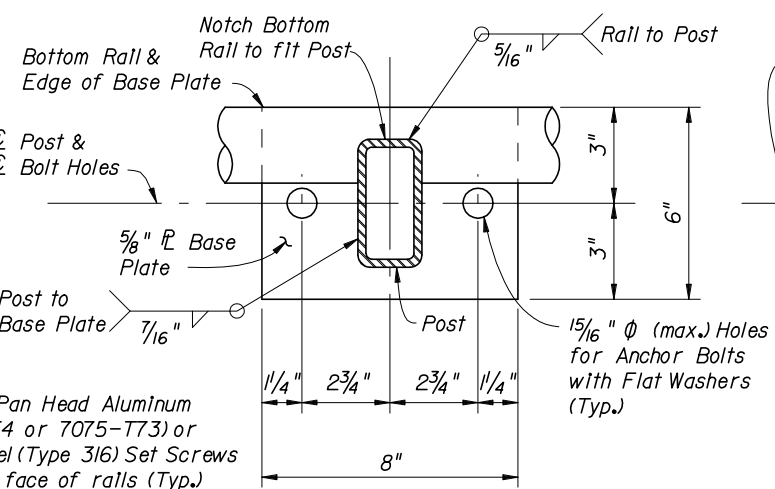

**SECTION G-G  
BASE PLATE AND BOTTOM RAIL CONNECTION**

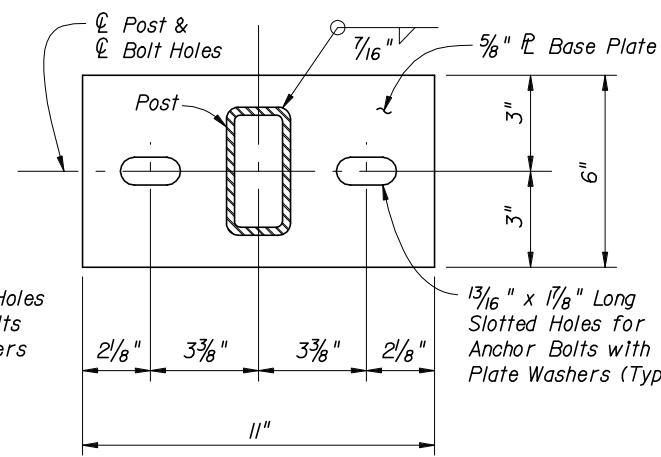

**ALTERNATE SLOTTED BASE  
PLATE DETAIL**

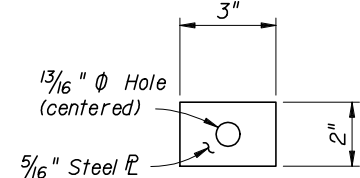

**PLATE WASHER DETAIL**

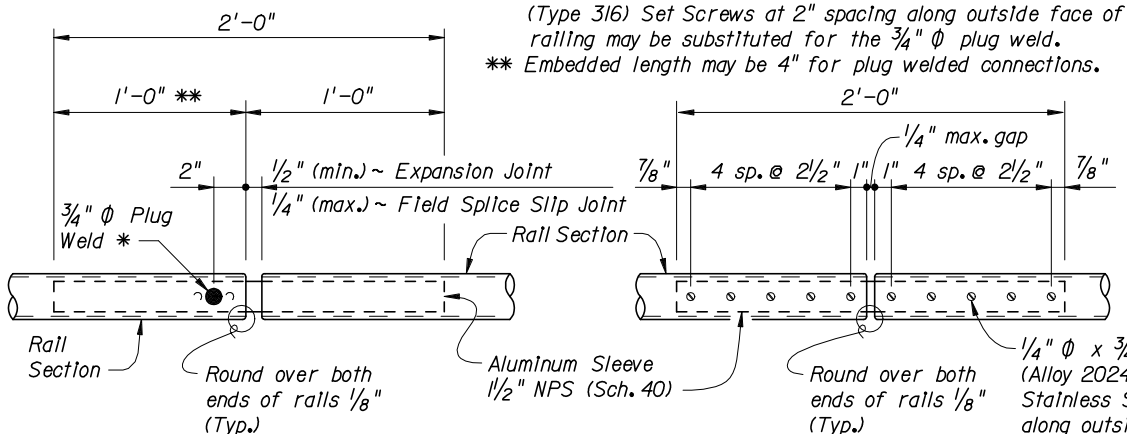

**DETAIL "D" - EXPANSION JOINT**  
(FIELD SPLICE SLIP JOINT SIMILAR)

**DETAIL "E" - CONTINUITY  
FIELD SPLICE**

**CROSS REFERENCE:**  
For locations of Details "A", "B", "C",  
"D" and "E", see Sheet 1 of 2



2006 FDOT Design Standards

ALUMINUM PEDESTRIAN/BICYCLE PICKET RAILING

Last Revision  
07/01/05  
Sheet No.  
2 of 2  
Index No.  
860