

ELEVATION OF INSIDE FACE OF TRAFFIC RAILING WITH BICYCLE BULLET RAILING

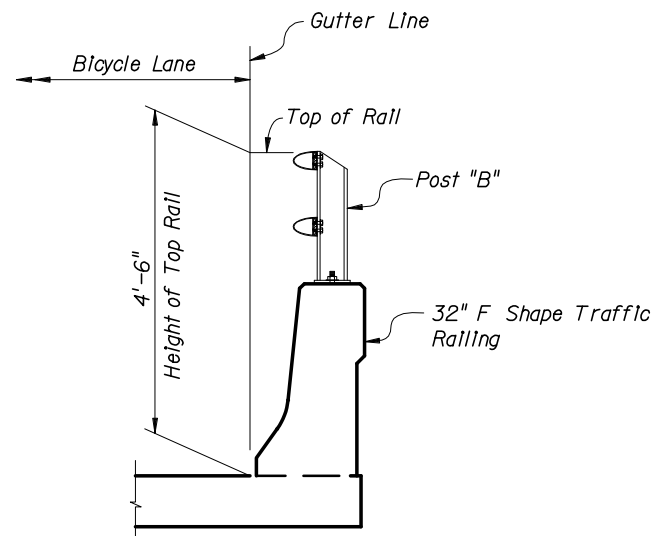

SECTION A-A  
TYPICAL SECTION THRU BRIDGE DECK  
(APPROACH SLAB SIMILAR)

NOTES:

BICYCLE RAILING: Railing shown above (see Section A-A) is intended to be used where a Bicycle Lane is required and a raised pedestrian sidewalk is not required.

RAIL AND POST DETAILS: For Post, Rail and Rail Expansion Joint fabrication and Installation Details and Notes see Index No. 822.

TRAFFIC RAILING DETAILS: For Traffic Railing Details, Reinforcement and Notes see Index No. 420.



2006 FDOT Design Standards

ALUMINUM PEDESTRIAN/BICYCLE BULLET RAILING  
FOR TRAFFIC RAILING (32" F SHAPE)

Last Revision	Sheet No.
07/01/05	1 of 1
Index No.	
821	