

- NOTES:**
1. A Pull Post Assembly is required at maximum intervals of 500'-0". See Sheet No. 3 of 4.
  2. Dimension is measured along Inside Face of Concrete Parapet.
  3. Dimension shown is for 32" F-Shape Traffic Railing Barriers as shown in Index No. 420. Adjust as required for other Traffic Railing Barriers.

**FENCING NOTES**

- FENCE INSTALLATION:**  
Install posts plumb (within a tolerance of  $\pm 1/2"$ ). Use shim plates as required to achieve plumb. The required quantity and thickness of shim plates will be determined in the field. Install chain link fence in accordance with ASTM F 567 as applicable.
- TRAFFIC RAILING BARRIER DETAILS:**  
See Superstructure Sheets for Traffic Railing Barrier details.
- CONCRETE PARAPET DETAILS:**  
See Index No. 820 - Pedestrian/Bicycle Railing for Concrete Parapet details. Provide fencing in lieu of aluminum bullet railing as shown on Index No. 820.
- LIMITS OF FENCING:**  
Limits of fencing are from begin of approach slab at Begin Bridge to end of approach slab at End Bridge, unless otherwise shown in the plans.
- PAYMENT:**  
Payment will be made under Fencing, Type R (Pedestrian Overpass). Payment includes posts, horizontal and expansion rails, brace bands, rail ends, combination rail ends, boulevard clamps, chain link fabric, tension wire, ties, hog rings, tension bars and bands, pipe clamps, base plates, anchor rods, bolts, nuts, washers, shim plates, spacers, neoprene pads, miscellaneous fence fittings and hardware and all incidental materials and labor required to complete installation of the fence.

- CROSS REFERENCE:**
- For Table of Fence Components and Table of Post Attachment Components see Sheet No. 2 of 4.
  - For Pull Post Assembly Detail, View A-A and Detail "A" see Sheet No. 3 of 4.
  - For Detail "B" and "E" see Sheet No. 4 of 4.



2006 FDOT Design Standards

**BRIDGE FENCING ( ENCLOSED )**

Last Revision	Sheet No.
07/01/05	1 of 4
Index No.	
<b>812</b>	

TABLE OF CHAIN LINK FENCE COMPONENTS		
COMPONENT	ASTM DESIGNATION	COMPONENT INFORMATION
Posts	F 1083	Galvanized Steel Pipe - 3" NPS, Schedule 40 (3.500" Outside Diameter, 0.216" Wall Thickness)
Horizontal Rails and Internal Sleeves	F 1083	Galvanized Steel Pipe - 2 1/2" NPS, Schedule 40 (2.875" Outside Diameter, 0.203" Wall Thickness)
Expansion Rails	F 1083	Galvanized Steel Pipe - 2" NPS, Schedule 40 (2.375" Outside Diameter, 0.154" Wall Thickness)
Chain Link Fabric (2" mesh with knuckled bottom selvages)	A 392	Zinc Coated Steel - No. 9 gage (coated wire diameter), Class 2 Coating
	A 491	Aluminum Coated Steel - No. 9 gage (coated wire diameter)
	F 668	Polyvinyl Chloride (PVC) Coated Steel - No. 9 gage Zinc Coated Wire (metallic-coated core wire diameter) ~ Specify the color of the polymer coating in the General Notes
Tension Wire	A 824 & A 817	Type II (Zinc Coated Steel Wire) - No. 7 gage, Class 4 Coating
		Type I (Aluminum Coated Steel Wire) - No. 7 gage
Tie Wires	F 626	Zinc Coated Steel Wire - No. 9 gage
Hog Rings	F 626	Zinc Coated Steel Wire - No. 12 gage
Brace Bands	F 626	No. 12 Gage (min. thickness) x 3/4" (min. width) Steel Bands (Beveled or Heavy)
Tension Bars	F 626	3/16" (min. thickness) x 3/4" (min. width) x Variable Height Steel Bars ~ Height = Tangent or Hoop Length - Barrier or Parapet Height - 2" max.
Tension Bands	F 626	No. 14 Gage (min. thickness) x 3/4" (min. width) Steel Bands
Miscellaneous Fence Components	F 626	Zinc Coated Steel ~ (Includes horizontal rail ends, combination rail ends, boulevard clamps and all other miscellaneous fittings and hardware)
Bolts	A 307	3/8" $\Phi$ x 4 1/4" Hex Head Bolts for Internal Sleeve connections 1/4" $\Phi$ x 4 1/4" Hex Head Bolts for Expansion Rail connections
Nuts	A 563	Hex Nuts for Internal Sleeve and Expansion Rail connections
Washers	F 436	Flat Washers for Internal Sleeve and Expansion Rail connections

LEGEND: NPS = Nominal Pipe Size

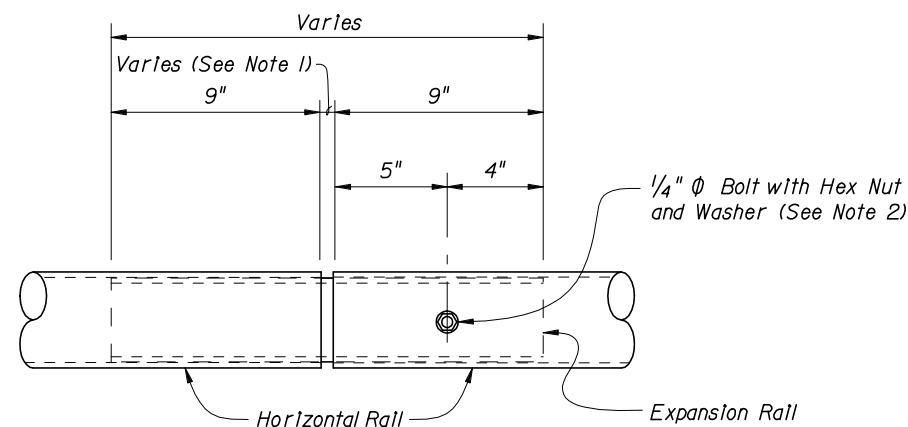

EXPANSION RAIL DETAIL

NOTES:

- This Dimension is the expansion joint opening plus 1/4". Expansion rails are required at expansion joint locations where the total movement exceeds 1", but is less than or equal to 6". Expansion rails are part of expansion assemblies when the total movement exceeds 6". Install expansion rails midway between the fence posts spanning the expansion joint.
- Install nuts for expansion rails finger-tight. Nuts will fully engage bolts with a minimum of one bolt thread extending beyond the nuts. Distort the first thread on the outside of the nut to prevent loosening.

TABLE OF POST ATTACHMENT COMPONENTS		
COMPONENT	ASTM DESIGNATION	COMPONENT INFORMATION
Pipe Clamps	A 36 or A 709 Grade 36	1/4" Steel $\bar{L}$
Base Plates	A 36 or A 709 Grade 36	3/4" Steel $\bar{L}$
Shim Plates	A 36 or A 709 Grade 36 or B 209 Alloy 6061-T6 or B 221 Alloy 6063-T5	Plate thicknesses as required; Holes in shim plates will be 3/4" $\Phi$
Spacers	-	1/4" $\bar{L}$ for all materials
Pipe Clamp Connection	Adhesive Anchor Rods	F 1554 Grade 36 Fully threaded Headless Anchor Rods ~ 5/8" $\Phi$ x 6" (no spacer) or 5/8" $\Phi$ x 7 1/4" (with spacer)
	CIP Anchor Rods	F 1554 Grade 36 Hex Head Anchor Rods ~ 5/8" $\Phi$ x 6" (no spacer) or 5/8" $\Phi$ x 7 1/4" (with spacer)
Base Plate Connection	Adhesive Anchor Rods	F 1554 Grade 36 Fully threaded Headless Anchor Rods ~ 7/8" $\Phi$ x 14 1/2"
	CIP Anchor Rods	F 1554 Grade 36 Hex Head Anchor Rods ~ 7/8" $\Phi$ x 14 1/2"
Bolts	A 307	3/8" $\Phi$ x 4 3/4" Hex Head Bolts for Pipe Clamp Connections to Posts
Nuts	A 563	Hex Nuts for Pipe Clamp and Base Plate Connections
Washers	F 436	Flat Washers for Pipe Clamp and Base Plate Connections
Neoprene Pads	-	In accordance with Specification Section 932

POST ATTACHMENT NOTES

ANCHOR RODS, NUTS AND WASHERS:

After the nuts have been tightened, distort the Anchor Rod threads to prevent removal of the nuts. Coat distorted threads and exposed trimmed ends of anchors with a galvanizing compound in accordance with Specification Section 971.

COATINGS:

Hot-dip galvanize all Nuts, Washers, Bolts, CIP Anchor Rods, Adhesive Anchors and Fence Framework (Posts, Internal Sleeves, Shim Plates, Base Plates, Pipe Clamps and Spacers) in accordance with Specification Section 962. Hot-dip galvanize Fence Framework after fabrication.

ADHESIVE-BONDED ANCHORS AND DOWELS:

Adhesive Bonding Material Systems for Anchors and Dowels will comply with Specification Section 937 and be installed in accordance with Specification Section 416.

WELDING:

All welding will be in accordance with the American Welding Society Structural Welding Code (Steel) ANSI/AWS D1.1 (current edition). Weld metal will be E60XX or E70XX. Nondestructive testing of welds is not required.



2006 FDOT Design Standards

BRIDGE FENCING (ENCLOSED)

Last Revision	Sheet No.
07/01/05	2 of 4
Index No.	
812	

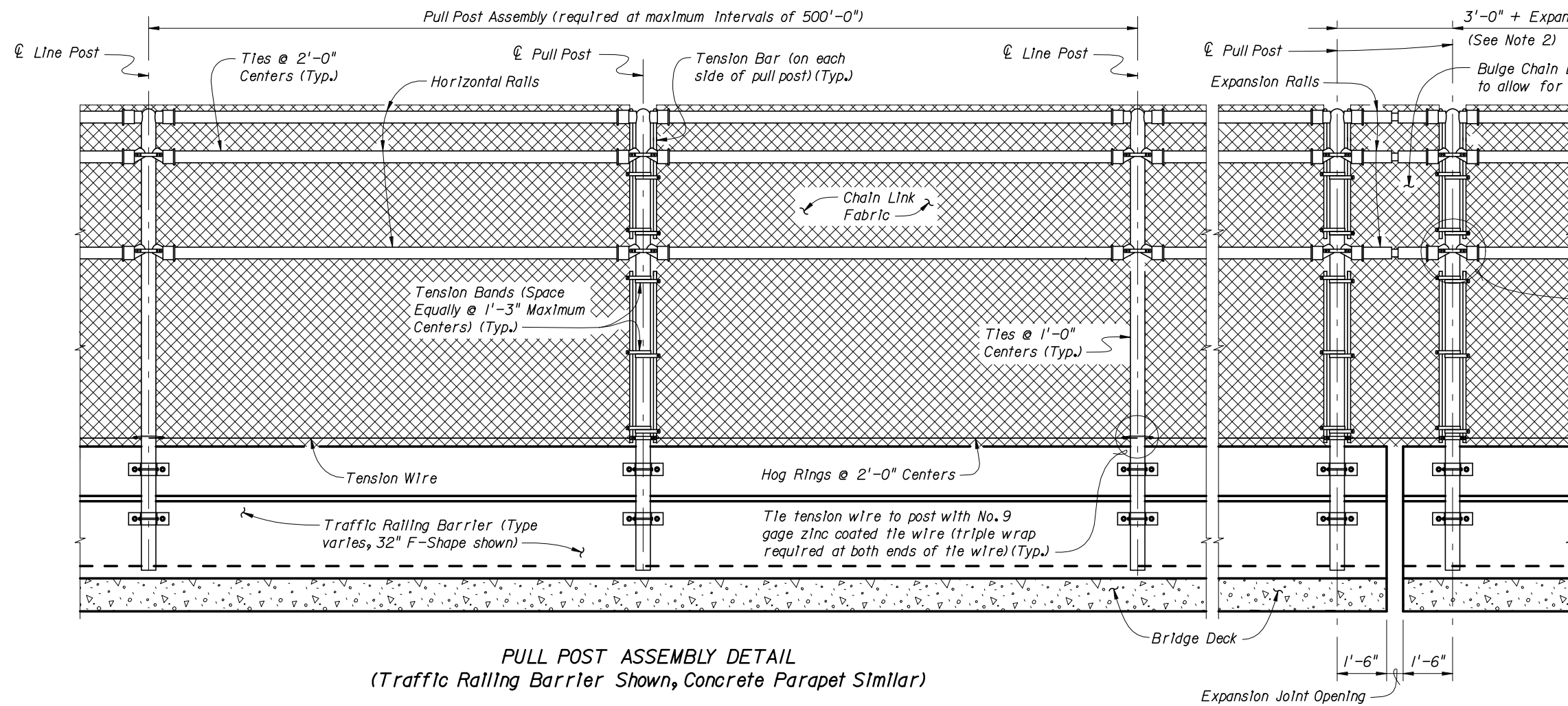

**PULL POST ASSEMBLY DETAIL**  
(Traffic Railing Barrier Shown, Concrete Parapet Similar)

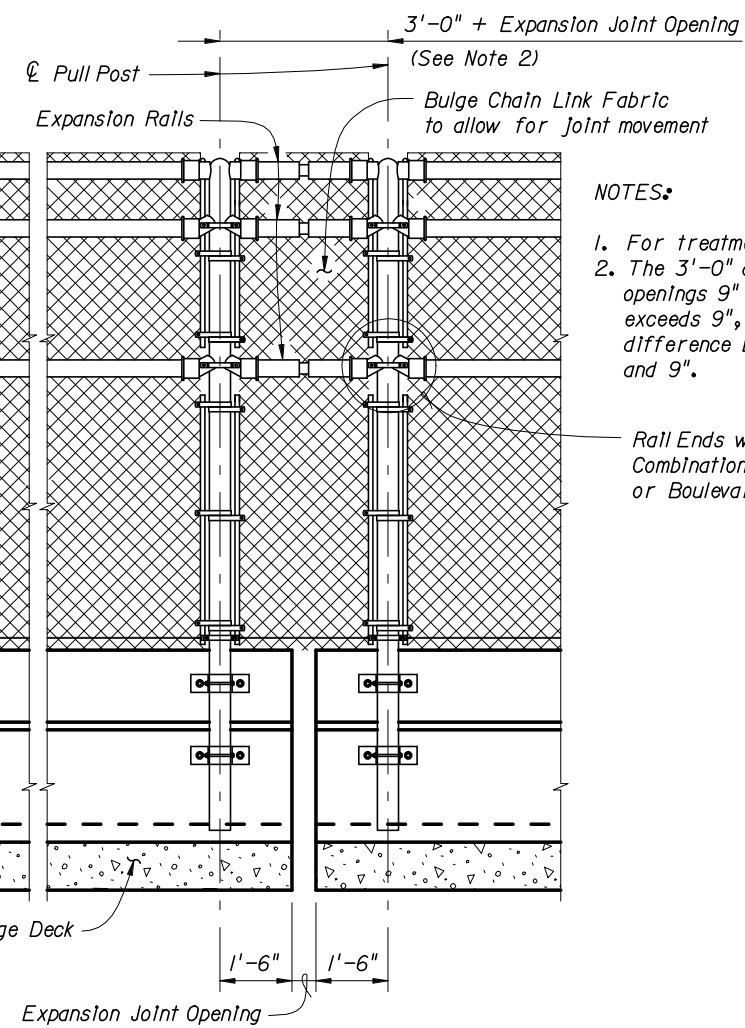

**EXPANSION ASSEMBLY DETAIL**  
(Required only at expansion joint locations where total movement exceeds 6")

- NOTES:**
1. For treatment at bridge ends, see Sheet No. 1 of 4.
  2. The 3'-0" dimension shown is for expansion joint openings 9" or less. If the expansion joint opening exceeds 9", increase this dimension by the difference between the expansion joint opening and 9".
- Rail Ends with Brace Bands (shown) or Combination Rail Ends with Brace Bands or Boulevards Clamps (Typ.)

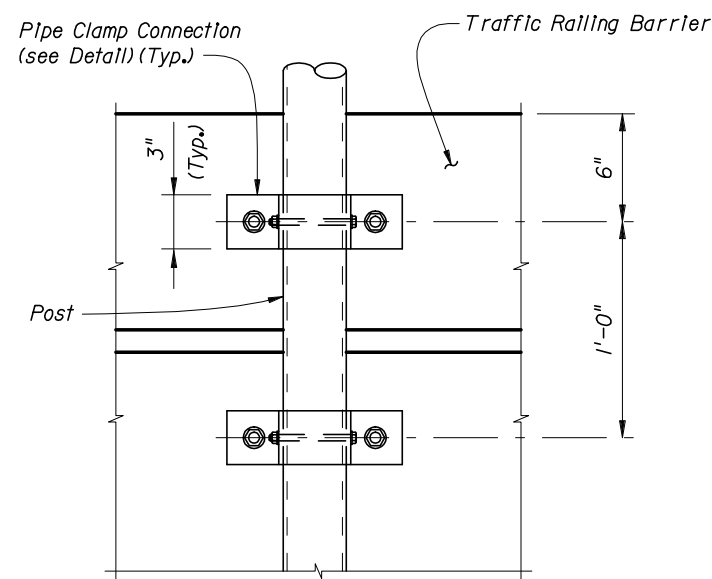

**VIEW A-A**

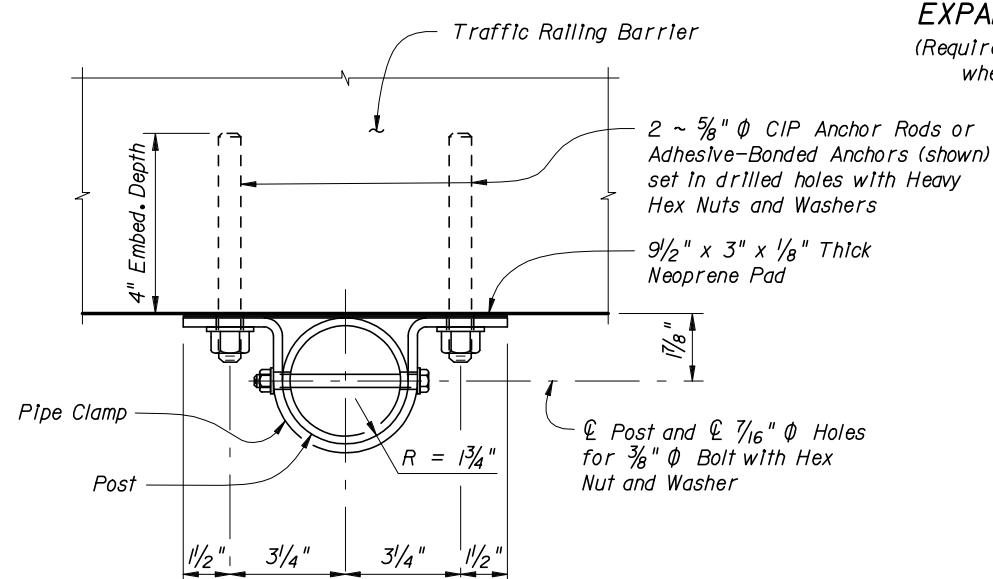

**PIPE CLAMP CONNECTION DETAIL**  
(Connection without spacer shown, Connection with spacer similar)

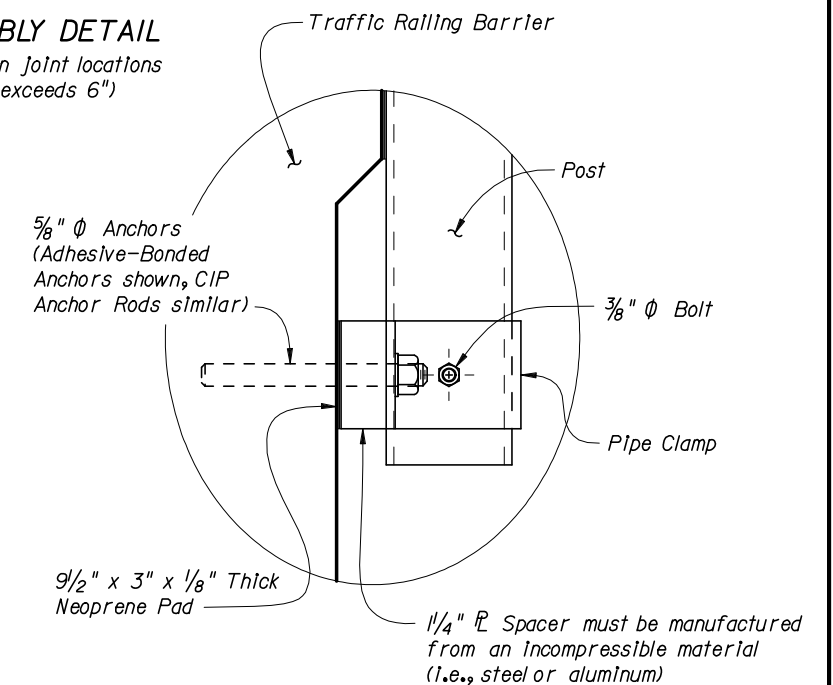

**DETAIL "A"**

**CROSS REFERENCE:**  
For location of View A-A and Detail "A" see Sheet No. 1 of 4.



2006 FDOT Design Standards

**BRIDGE FENCING ( ENCLOSED )**

Last Revision	Sheet No.
07/01/05	3 of 4
Index No.	
812	

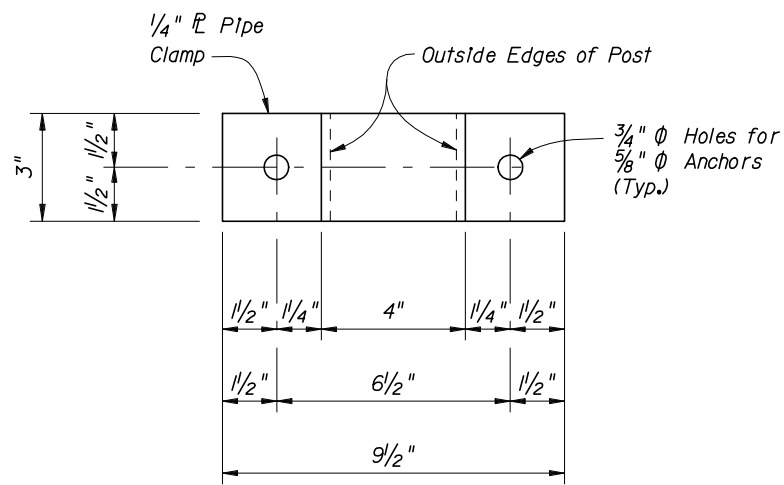

PIPE CLAMP DETAIL

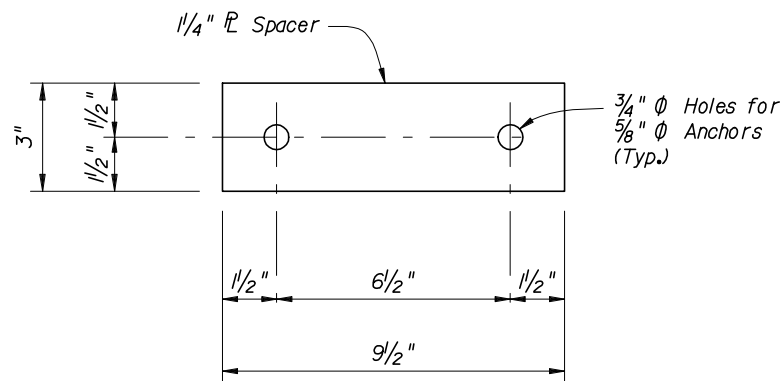

SPACER DETAIL

(Must be manufactured from an incompressible material (i.e., steel or aluminum))

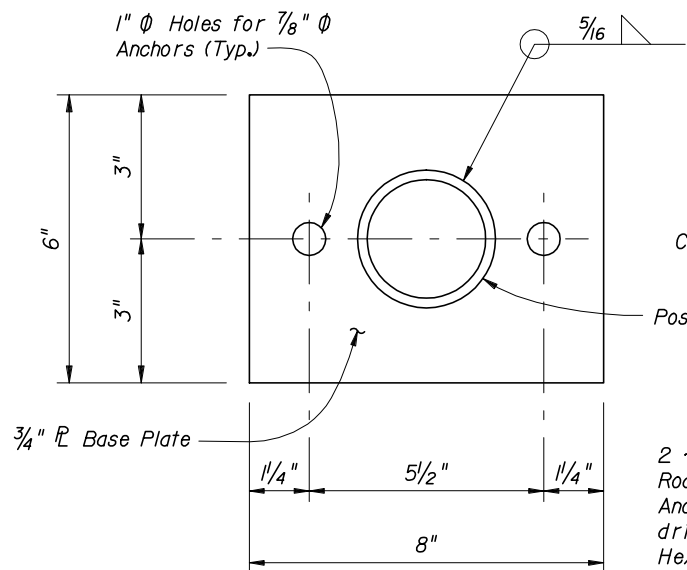

BASE PLATE DETAIL

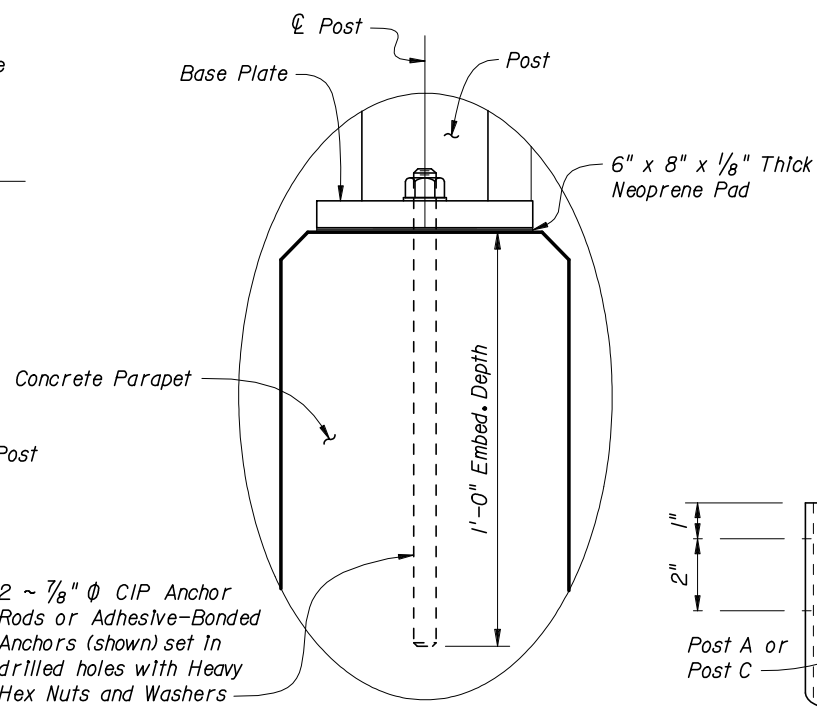

DETAIL "B"

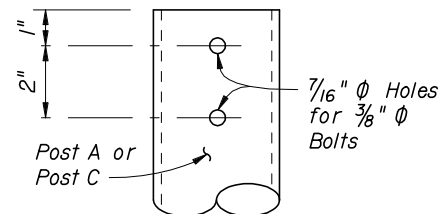

DETAIL "C"

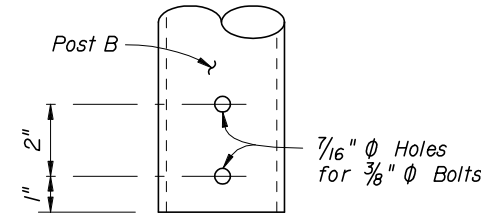

DETAIL "D"

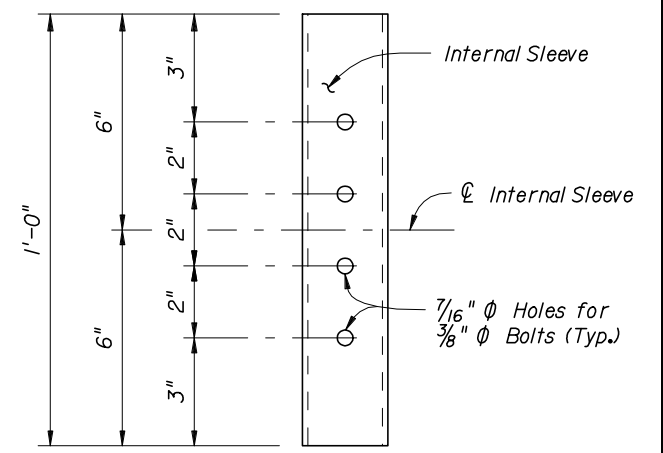

DETAIL "E"  
(INTERNAL SLEEVE DETAIL)

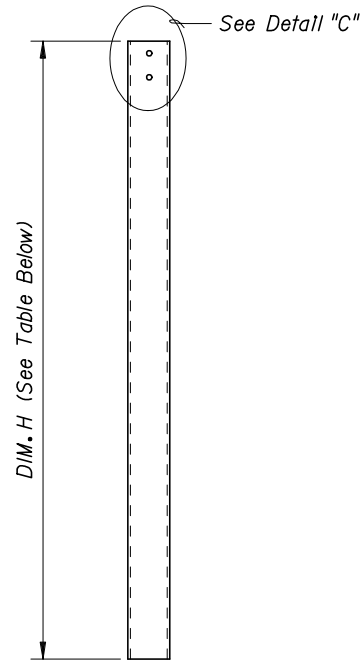

POST A DETAIL

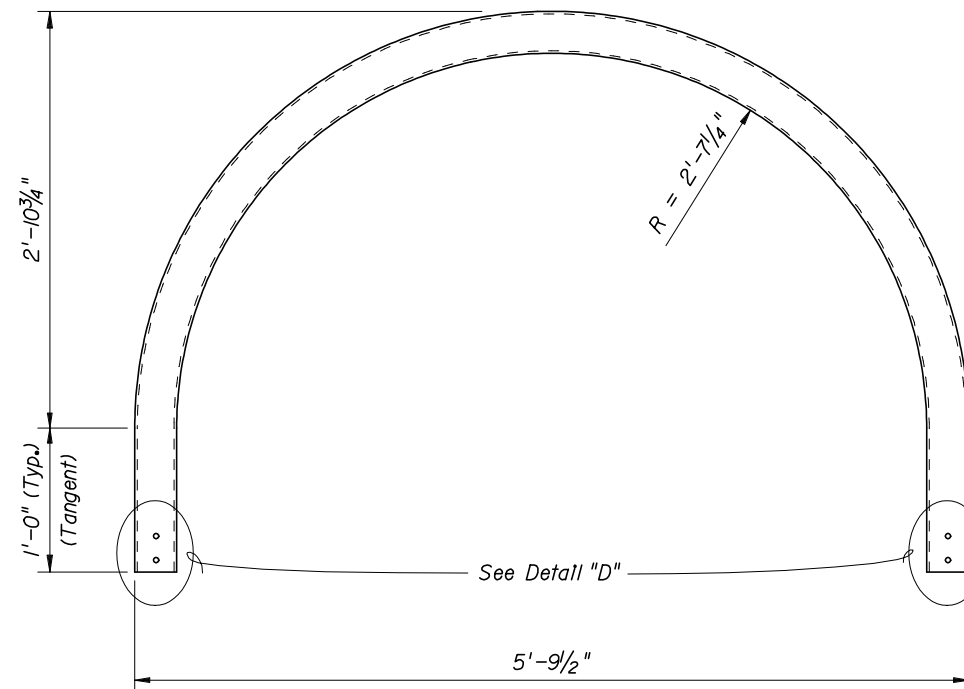

POST B DETAIL

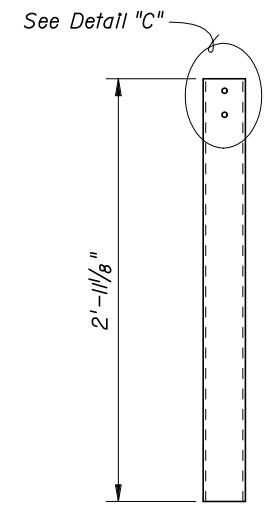

POST C DETAIL

SIDEWALK CROSS-SLOPE	DIM. H
2% Left	5'-6 1/2"
2% Right	5'-4"

Note:  
Values shown at left for DIM. H are for 32" F-Shape Traffic Railing Barriers as shown in Index No. 420. Adjust as required for other Traffic Railing Barriers.

CROSS REFERENCE:  
For location of Details "B" and "E" see Sheet No. 1 of 4.



2006 FDOT Design Standards

BRIDGE FENCING (ENCLOSED)

Last Revision  
07/01/05  
Sheet No.  
4 of 4  
Index No.  
812