

LARGE PAVILION

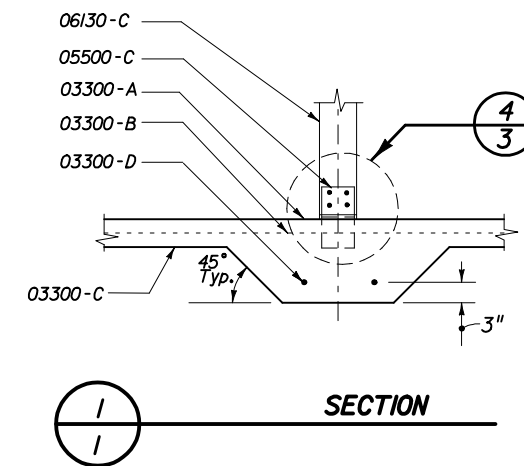

SECTION

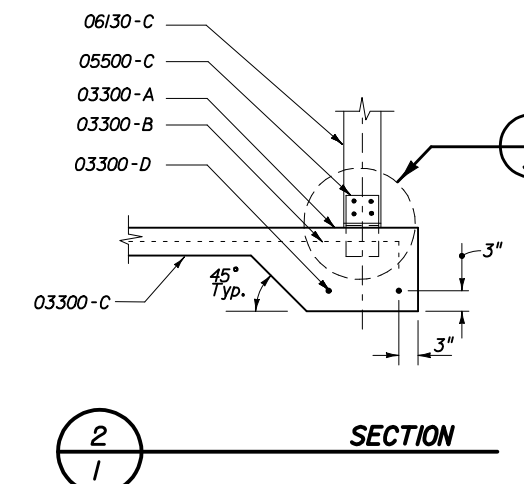

SECTION

NOTES

Keynotes On Sheet 2.

FLOOR

6" Reinf. Concrete Slab w/WWF6 x 6-W1.4 x W1.4

1'-6" x 1'-6" Drop Footing At Slab Perimeter & Interior Posts.

Harden & Broom Finish Slab Surface.

STRUCTURE

Posts: 8 x 8 PT

Beams: 4 x 6 PT

Framing: 4x PT As Described.

Misc Members: 1x and 2x As Described.

ROOF

3" x 6" T&G Wood Decking.

30# Asphalt Impregnated Fiberglass Felt Underlayment.

Standing Seam Metal Roof (24 GA Steel Or .032 Alum.) w/ Kynar 500 Finish.

Structure, Decking And Roofing Shall Be Designed To Withstand 130 mph Wind Load.

BUILDING CODE

Picnic Pavilions Shall Be Constructed According To The Requirements Of The Appropriate Sections Of Applicable "Standard Building Code" or "South Florida Building Code", Current, Adopted Edition.

PICNIC PAVILIONS

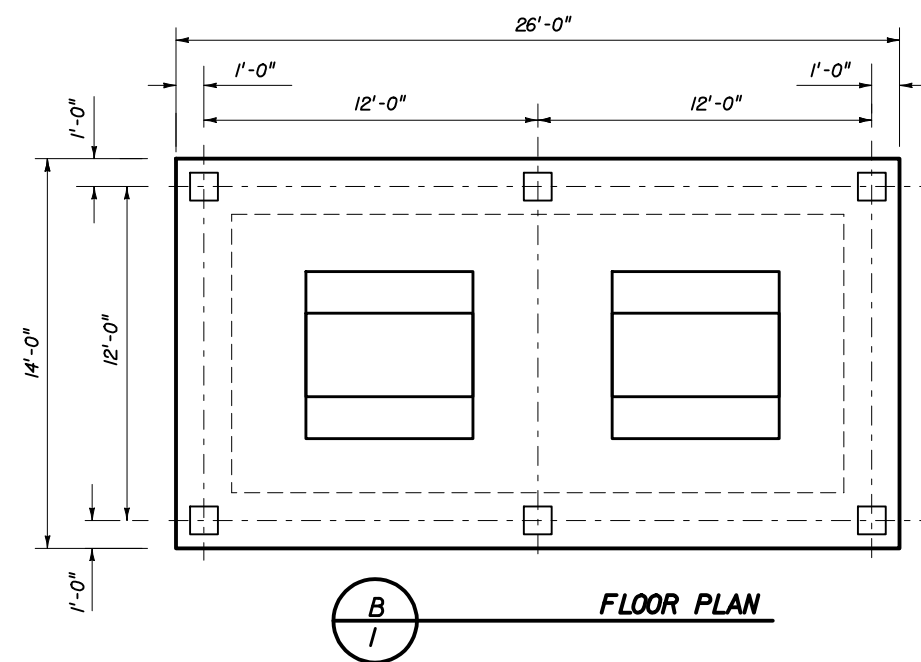

SMALL PAVILION

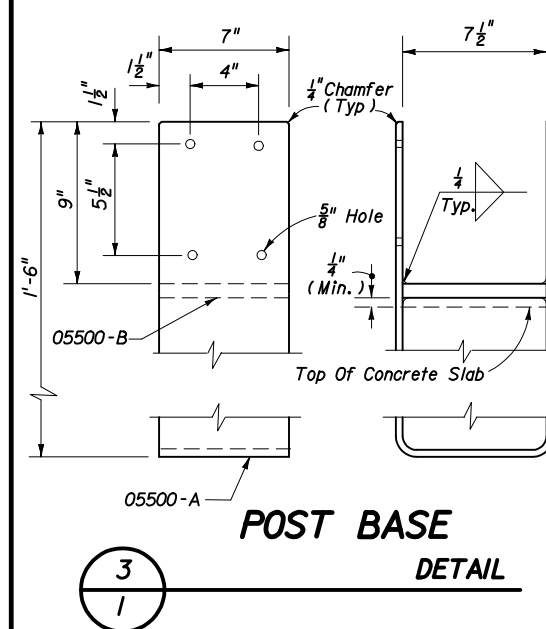

POST BASE

DETAIL



2006 FDOT Design Standards

REST AREA EQUIPMENT

Last Revision
00

Sheet No.
1 of 3

Index No.
530

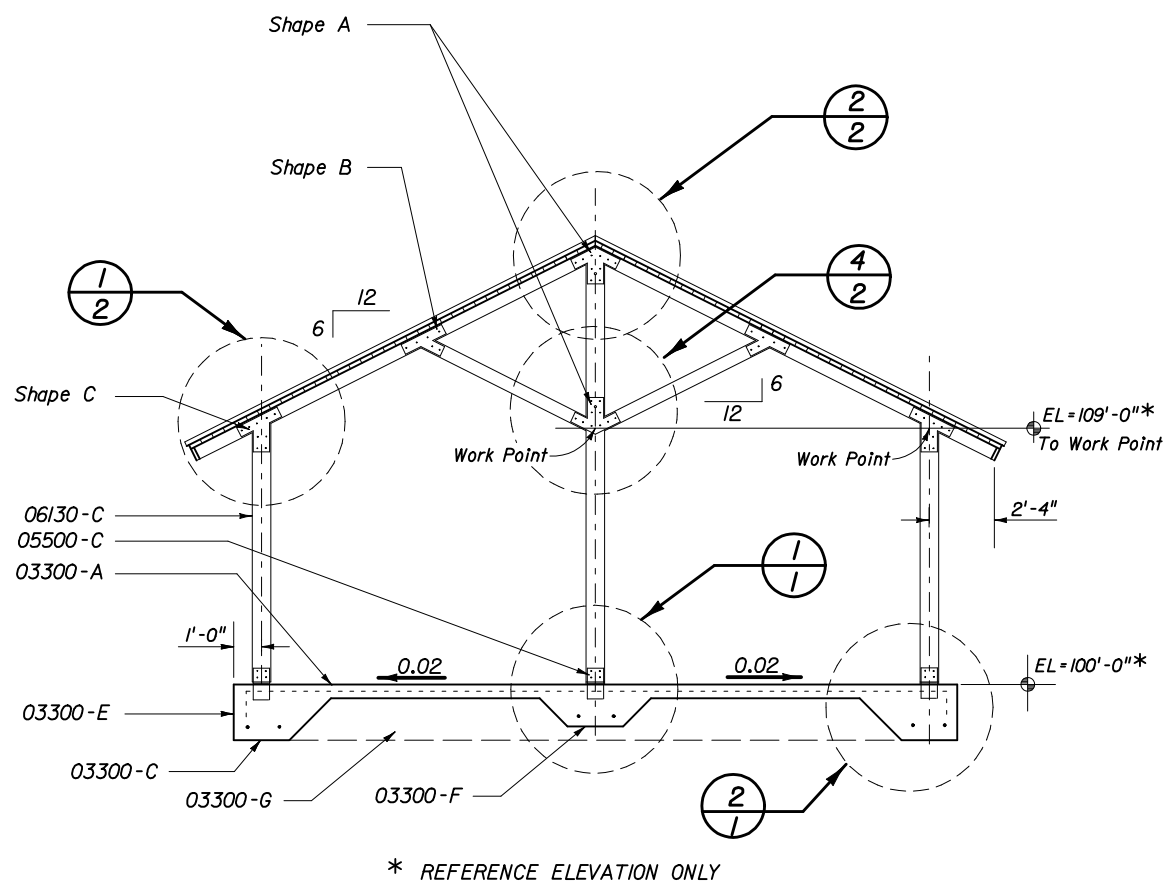

* REFERENCE ELEVATION ONLY

SECTION
A
2

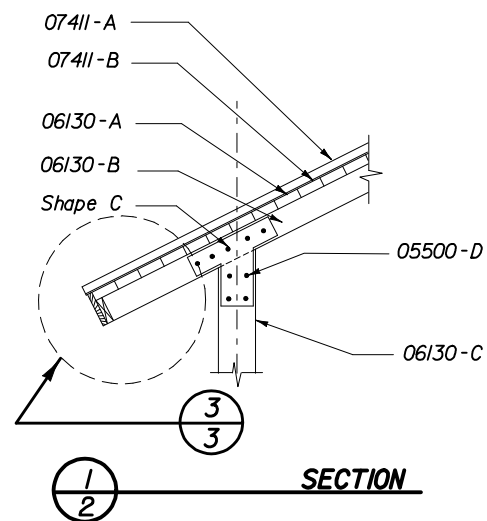

SECTION
1
2

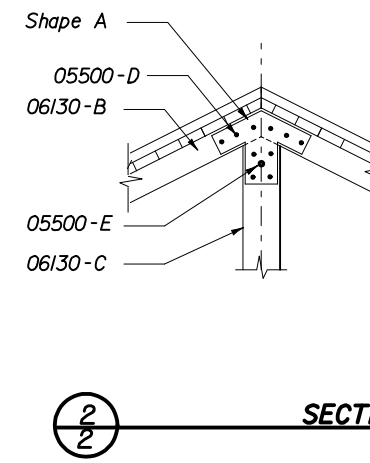

SECTION
2
2

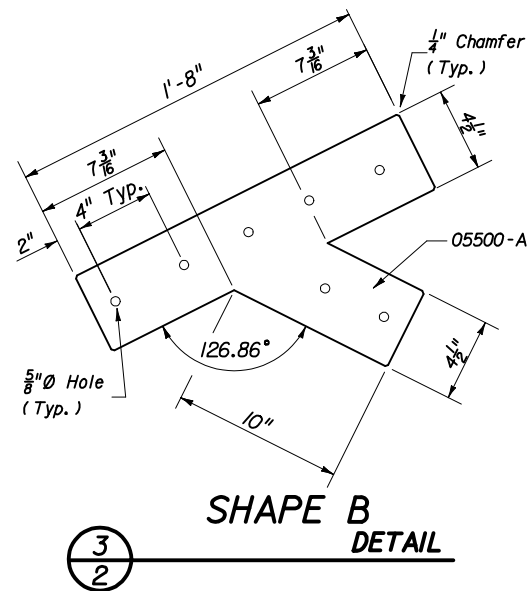

SHAPE B
DETAIL
3
2

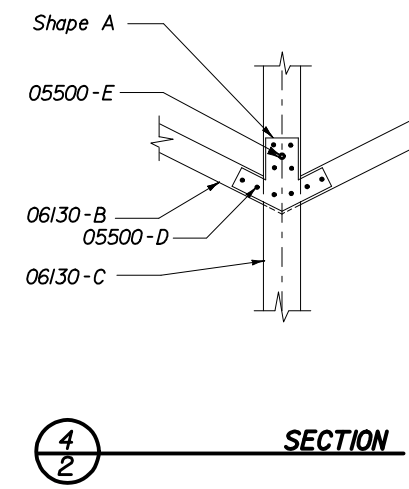

SECTION
4
2

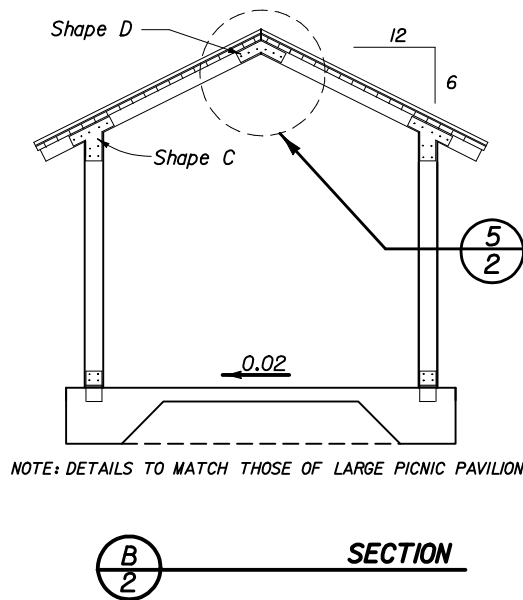

NOTE: DETAILS TO MATCH THOSE OF LARGE PICNIC PAVILION

SECTION
B
2

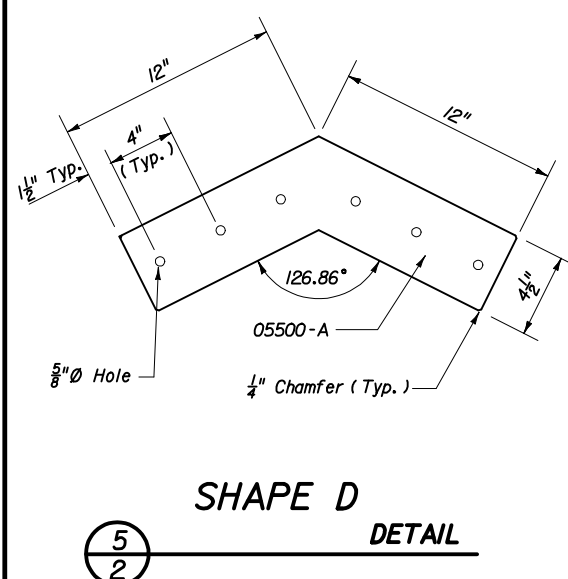

SHAPE D
DETAIL
5
2

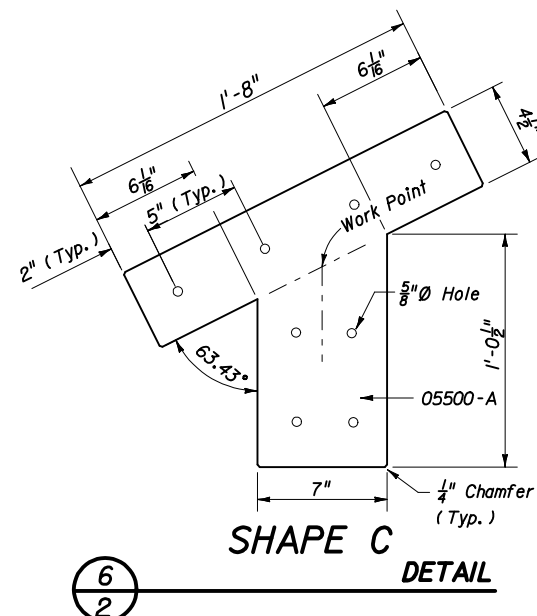

SHAPE C
DETAIL
6
2

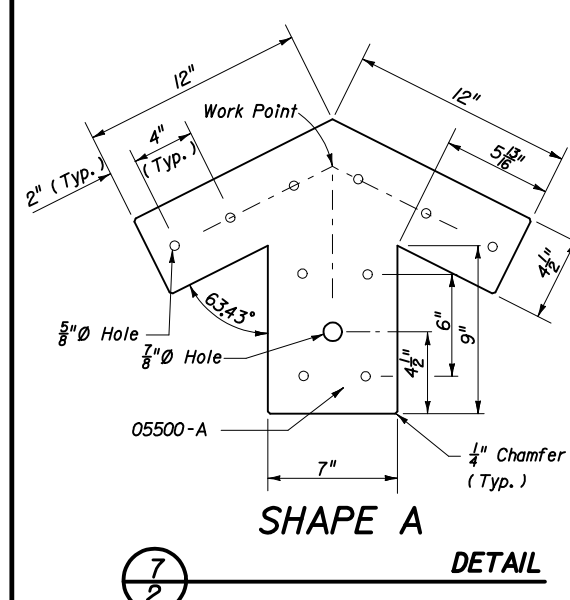

SHAPE A
DETAIL
7
2

KEYNOTES

- 03300-A Class II Conc Slab
- 03300-B 6" x 6"-W1.4 x W1.4 @ 12" Of Slab
- 03300-C 6 Mil Vapor Barrier
- 03300-D #5 Rebar Cont. (2 Required)
- 03300-E 24" x 24" Drop Footing
- 03300-F 18" x 18" Drop Footing
- 03300-G 6" Min Comp Sand Fill
- 03300-H #5 x 18" Rebar (4 Required)

- 05500-A 3/8" Galv. Steel Plate
- 05500-B 1/2" Galv. Steel Plate
- 05500-C Post Base
- 05500-D 1/2" Ø Bolt, Washer & Nut (Typ)
- 05500-E 3/4" Ø Eyebolt, Washer & Nut For Cross Brace Bars
- 05500-F 1/2" Ø Steel Rod w/Turnbuckle

- 06130-A 3" x 6" T&G Wood Decking
- 06130-B 4" x 6" PT Wood Frame
- 06130-C 8" x 8" PT Wood Post
- 06130-D 2" x 6" PT Wood Fascia
- 06130-E 1" x 10" PT Wood Fascia
- 06130-F 3/4" ± Wood Shim

- 07411-A Standing Seam Metal Roof
- 07411-B Felt Underlayment

Alternate Material Note:
These structures are shown with timber frames and decking. Alternate materials (ie. aluminum, steel, etc.) may be used when submittals are signed and sealed by a specialty engineer as per Section 5.1 of the Standard Specifications and when approved by the Engineer.

PICNIC PAVILIONS



2006 FDOT Design Standards

REST AREA EQUIPMENT

Last Revision 00	Sheet No. 2 of 3
Index No. 530	

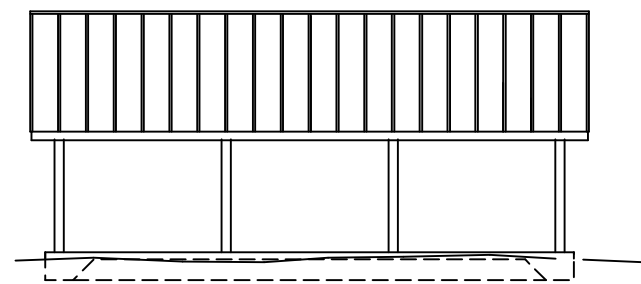

A
3 SIDE ELEVATION

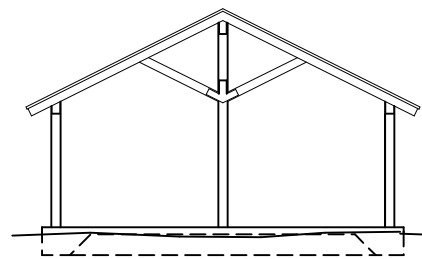

B
3 END ELEVATION

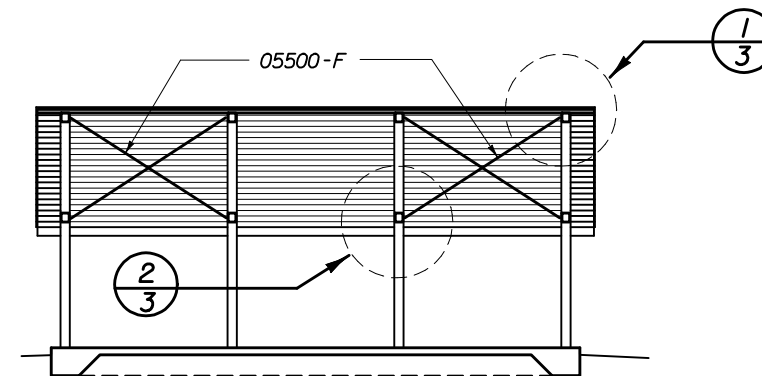

C
3 SECTION

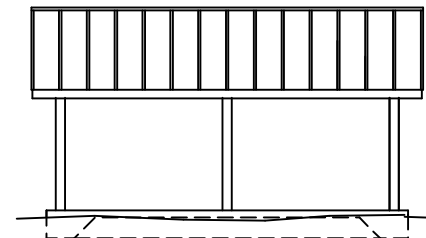

D
3 SIDE ELEVATION

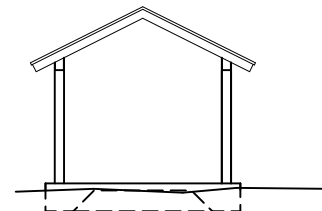

E
3 END ELEVATION

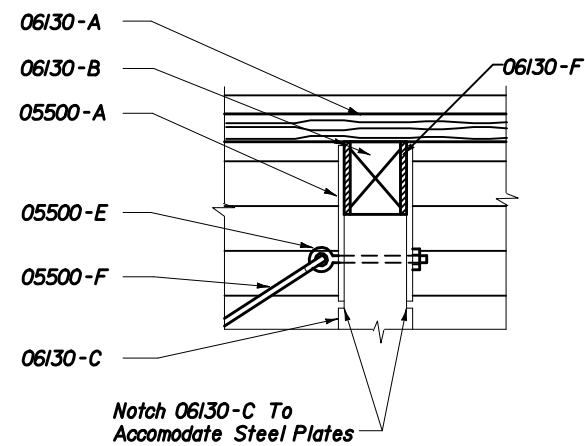

1
3 DETAIL

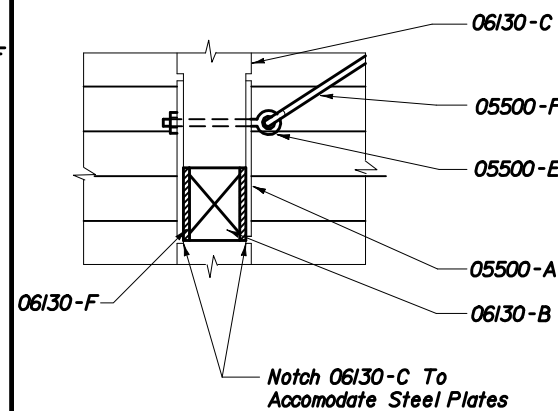

2
3 DETAIL

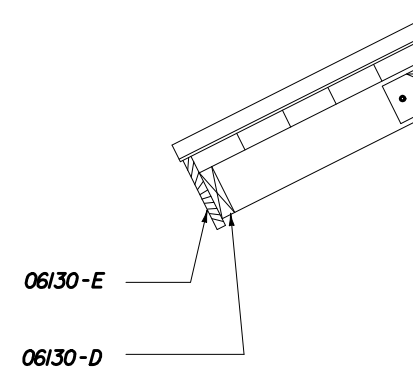

3
3 DETAIL
Similar At Roof Rake

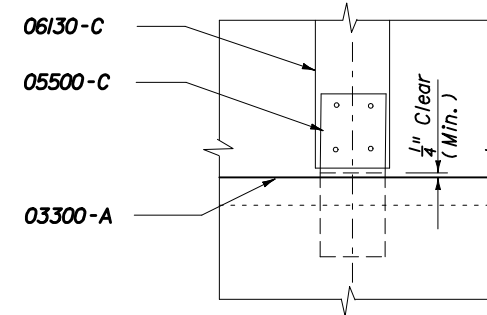

4
3 DETAIL

SPECIFICATIONS

Keynotes On Sheet 2.

CONCRETE

Concrete: FDOT Class II.

Reinforcing Bars: ASTM A615/A615M, Grade 400.

Welded Wire Fabric: ASTM A-185.

Vapor Barrier: Black 6-Mil Polyethylene.

STEEL

Galvanized Steel Plate: Steel Plate ASTM A446 With G90 Zinc Coating.

Galvanized Fasteners: High-Strength Bolts And Nuts, ASTM A325 With G90 Zinc Coating.

Galvanize Shapes After Fabrication, Make Field Repairs To Galvanizing With High Zinc Dust Content Paint, Complying With SSPC-Paint-20.

WOOD

Comply With American Institute For Timber Construction AITC 108, "Standard For Heavy Timber Construction."

For Solid Wood Decking, Comply With AITC 112, Standard For Tongue And Groove Heavy Timber Standard."

Species: Douglas Fir, Hem-fir, Or Southern Pine, At Fabricator's Option.

Preservative Treatment: Pressure Treat Fabricated Members With Waterborne Solution For Above Ground Use, Complying With AWWA C2.

Wood Decking: Predrill Decking At 30" Centers For Lateral Spiking To Adjacent Units. Spikes To Be 20d Galvanized Common.

PICNIC TABLES

Picnic Tables And Benches Shall Be 6' x 6' w/Heavy Galvanized Pipe Frames And Recycled Plastic Wood Seats And Table Tops. All Tables Shall Be Of Walk Thru Design Suitable For Exterior Locations. Tables At Accessible Pavilions Shall Meet The Requirements Of The Americans With Disabilities Act (ADA) Accessibility Guidelines.

PICNIC PAVILIONS



2006 FDOT Design Standards

REST AREA EQUIPMENT

Last Revision
00

Sheet No.
3 of 3

Index No.
530