

Bars 6D spacing at Railing Joints (Typ. on bridge except as noted for skewed deck joints)

**PARTIAL PLAN OF RAILING**

\*Non-skewed deck joint shown, actual joint dimensions and orientation vary. For treatment at skewed deck joints see Skew Detail, Index No. 480. Open Railing Joints at Deck Expansion Joint locations shall match the dimension of the Deck Joint. Deck Joint at Begin Bridge or End Bridge shown, Deck Joint at  $\odot$  Pier or Intermediate Bent similar.

- \*\* $3/4$ " Intermediate Open Joints shall be provided at:
- (1) - Substructure supports where existing bridge deck is continuous.
  - (2) - Midspan where span length exceeds 90 ft.
  - (3) - Intermediate locations (equally spaced) between midspan and substructure supports where span length exceeds 180 ft.

**CROSS REFERENCE:**

For General Notes, Estimated Quantities, Dowel Detail, Expansion Dowel Detail, Reinforcing Steel Notes & Bending Diagrams see Index No. 480.

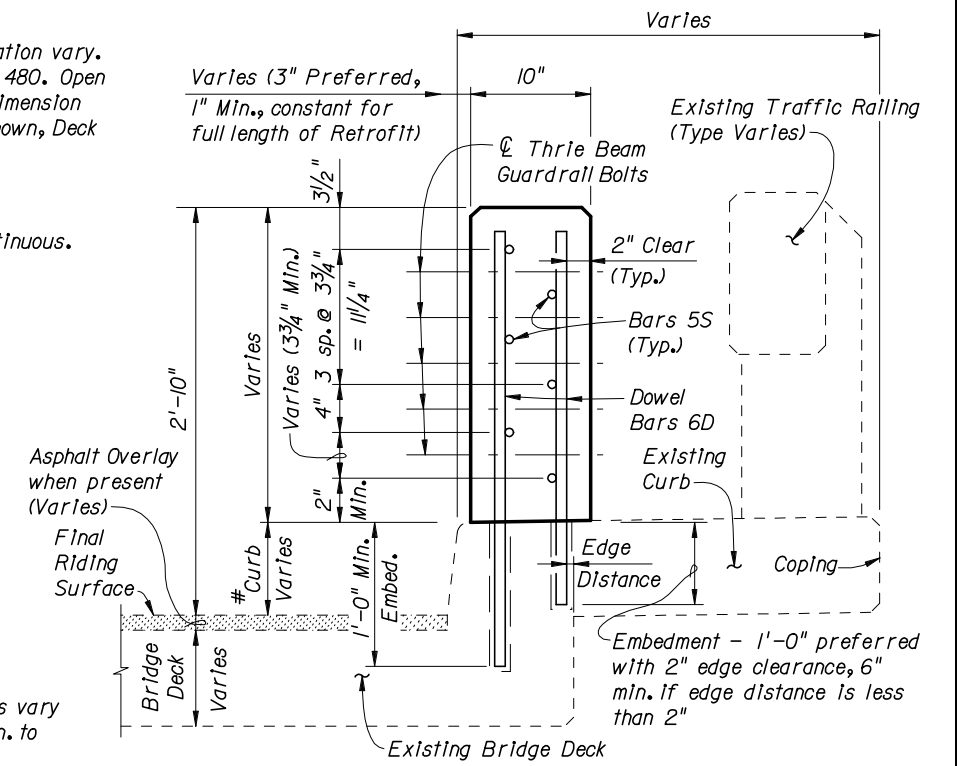

**SECTION A-A  
TYPICAL SECTION THRU RAILING ON BRIDGE DECK**

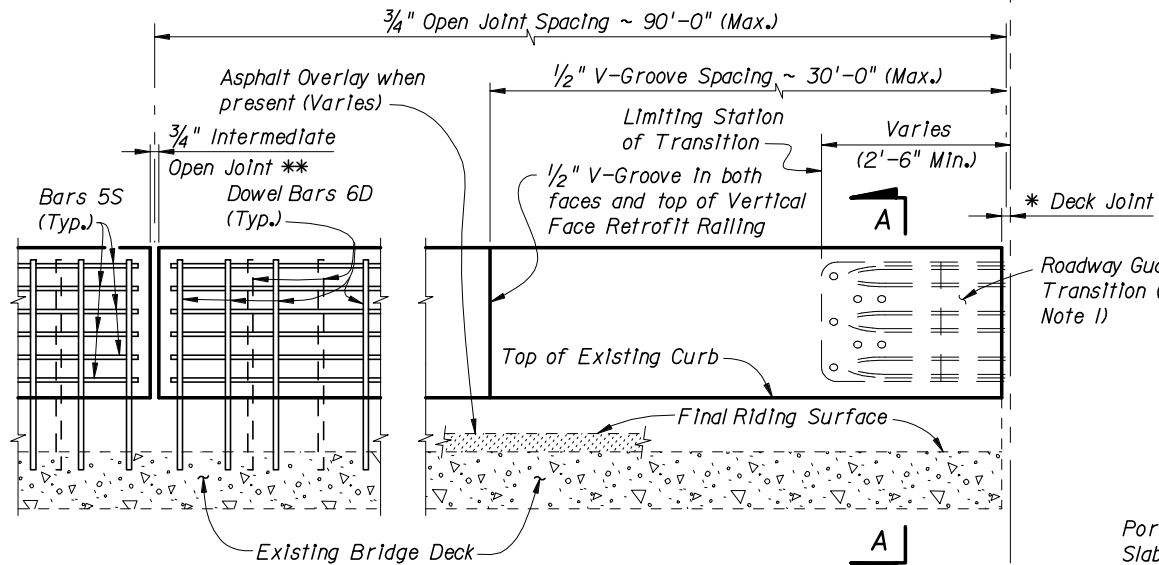

**PARTIAL ELEVATION OF INSIDE FACE OF RAILING  
(Existing Traffic Railing, Expansion Dowel Assemblies & Bars 4C not shown for clarity)**

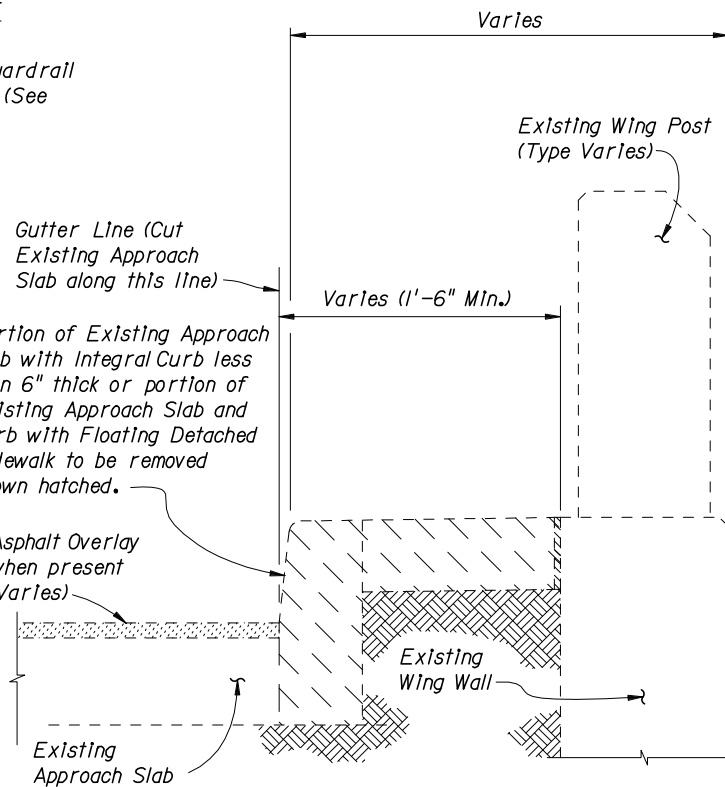

**TYPICAL SECTION THRU EXISTING APPROACH SLAB AND END BENT WING WALL  
SHOWING LIMITS OF REMOVAL  
(SCHEMES 4 AND 5 ONLY)**

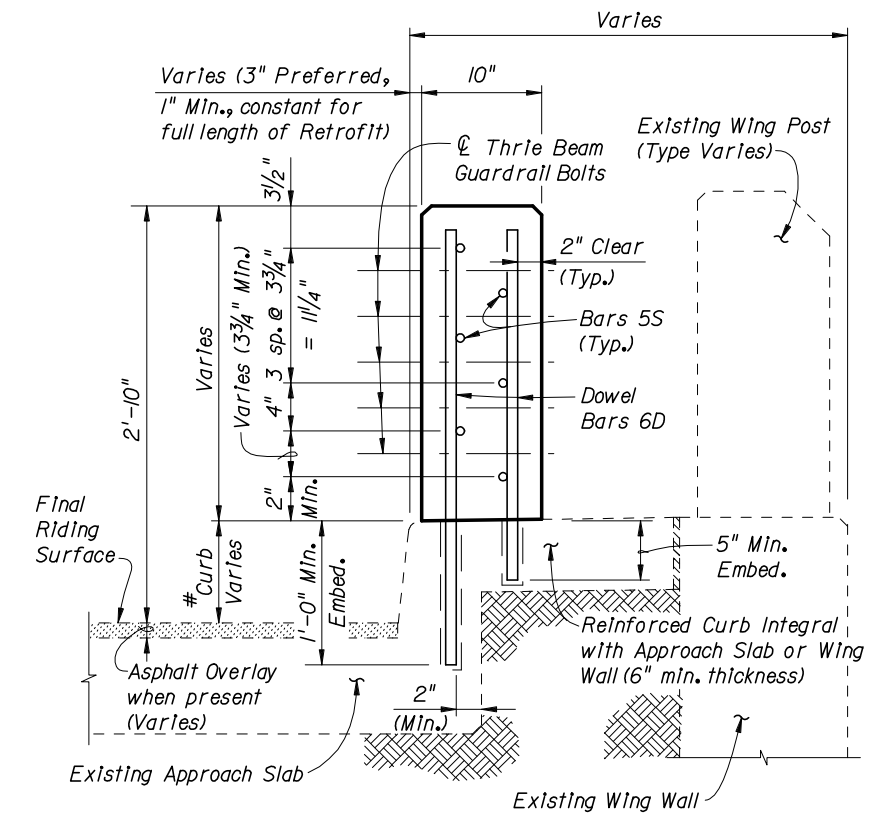

**SECTION B-B  
TYPICAL SECTION THRU RAILING ALONG APPROACH SLAB  
(SCHEMES 2 AND 3 ONLY)**

**NOTES:**

1. On approach end provide a Roadway Guardrail Transition, Index No. 402 (as shown) or other site specific treatment. See Roadway Plans for limiting station of Roadway Guardrail Transition or other site specific treatment. If limiting station of Roadway Guardrail Transition is on the bridge, attach Thrie Beam Terminal Connector to railing as shown above. If limiting station of Roadway Guardrail Transition is along the Wing Wall, see Schemes 2, 3, 4 or 5 Index No. 482, Sheets 3 and 4 of 4. On skewed bridges, if the skew along the deck joint extends across the width of the railing, the 2'-6" minimum dimension shall apply to both the front and back face of the railing. For treatment of trailing end see Roadway Plans.
2. Field cut Bars 5S and Dowel Bars 6D to maintain clearance within Vertical Face Retrofit Railing.
3. Areas where existing structure has been removed that are not encased in new concrete shall match adjoining areas and shall be finished flat by grouting or grinding as required. Exposed existing reinforcing steel that is not encased in new concrete shall be burned off 1" below existing concrete and grouted over.

**TYPICAL TREATMENT OF RAILING ALONG BRIDGE**



2006 FDOT Design Standards

**TRAFFIC RAILING - (VERTICAL FACE RETROFIT)  
WIDE CURB**

Last Revision: 07/01/05  
Sheet No. 1 of 4  
Index No. 482

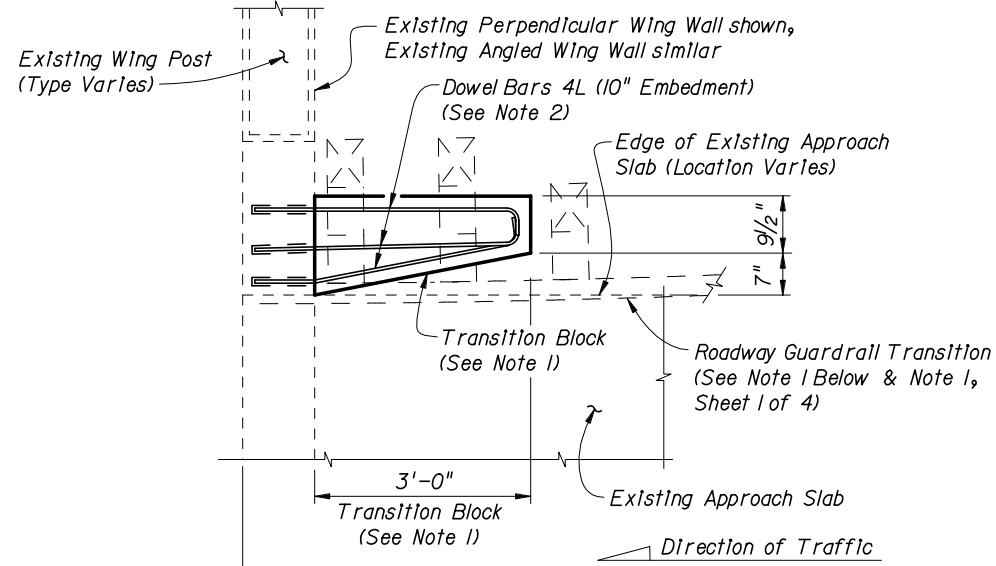

**PARTIAL PLAN OF RAILING**

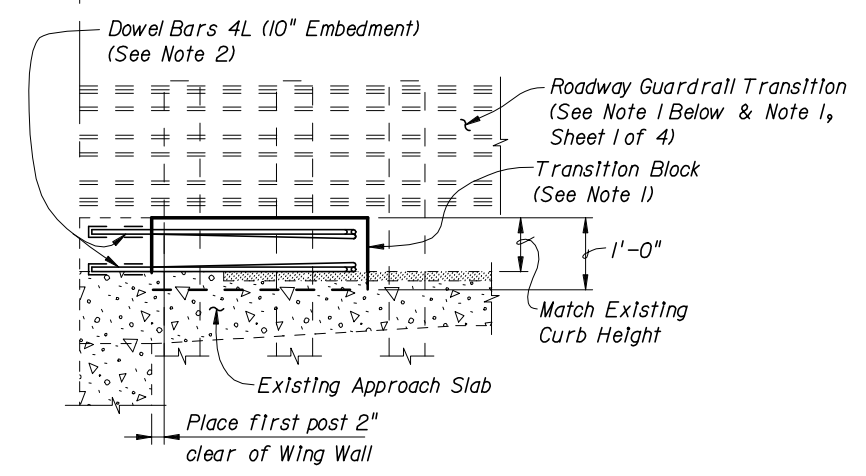

**PARTIAL ELEVATION OF INSIDE FACE OF GUARDRAIL  
(Existing Wing Post not shown for clarity)**

**SCHEME 1  
RAILING END TREATMENT FOR  
PERPENDICULAR OR ANGLED WING WALLS**

**SCHEME 1 NOTES:**

1. Provide Transition Block (as shown) or Curb if existing Approach Slab does not have a curb, see Roadway Plans. Shape and height of Transition Block or Curb shall match existing bridge curb. Railing End Transition and Transition Block may be omitted on trailing ends with no opposing traffic.
2. Field bend Dowel Bars 4L within Transition Block as required to maintain 2" top and side clearance and 3" bottom clearance.
3. If a Special Steel Guardrail Post is required for attachment to the top of a sloping Wing Wall, saw cut and remove a wedge shaped portion of the sloping Wing Wall as required to provide a level surface for post installation.

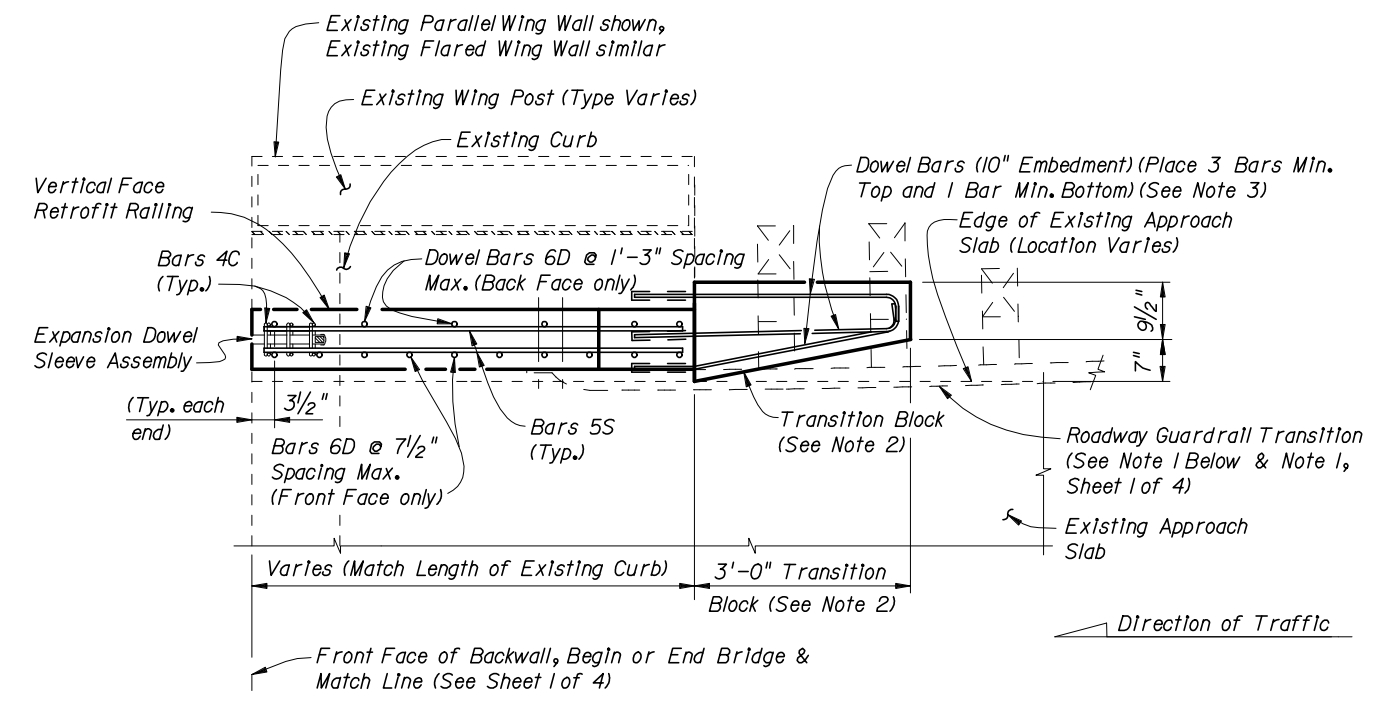

**PARTIAL PLAN OF RAILING**

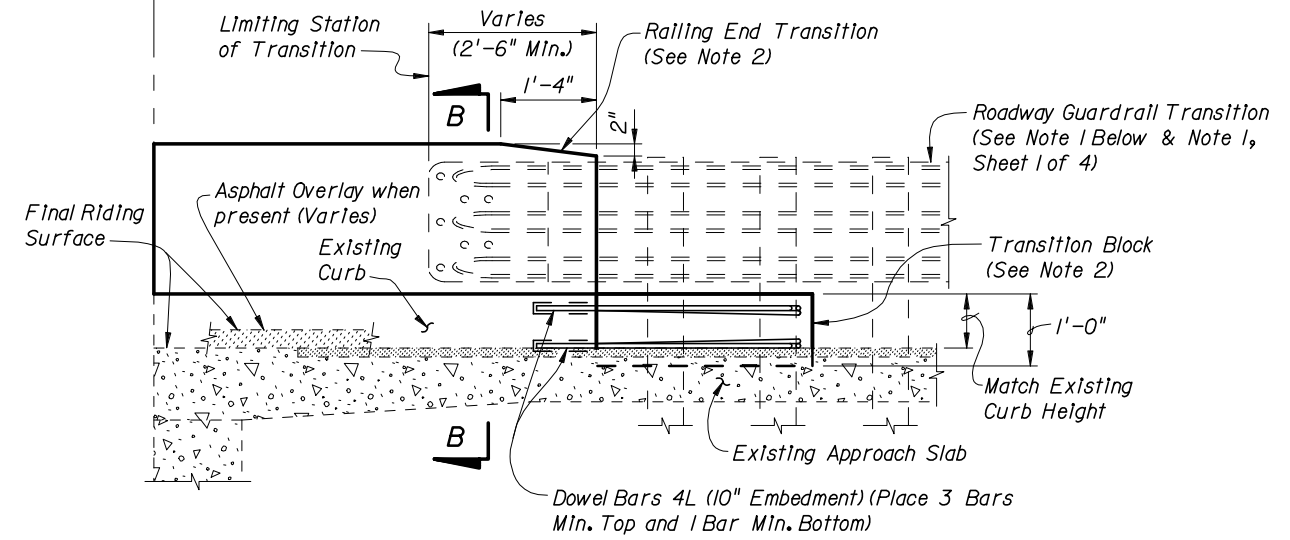

**PARTIAL ELEVATION OF INSIDE FACE OF RAILING  
(Existing Wing Post, Railing Reinforcing and Expansion Dowel Assemblies not shown for clarity)**

**SCHEME 2  
RAILING END TREATMENT FOR PARALLEL CURBS**

**SCHEME 2 NOTES:**

1. See Roadway Plans for limiting station of Roadway Guardrail Transition or other site specific treatment. If limiting station of Roadway Guardrail Transition is along the Wing Wall, attach Thrie Beam Terminal Connector to railing as shown above. If limiting station of Roadway Guardrail Transition is on the bridge, see Index No. 482, Sheet 1 of 4. On skewed bridges, if the skew along the deck joint extends across the width of the railing, the 2'-6" minimum dimension shall apply to both the front and back face of the railing.
2. Provide Transition Block (as shown) or Curb if existing Approach Slab Curb does not extend beyond end of existing End Bent Wing Wall, see Roadway Plans. Shape and height of Transition Block or Curb shall match existing bridge curb. Railing End Transition and Transition Block may be omitted on trailing ends with no opposing traffic.
3. Field bend Dowel Bars 4L within Transition Block as required to maintain 2" top and side clearance and 3" bottom clearance.



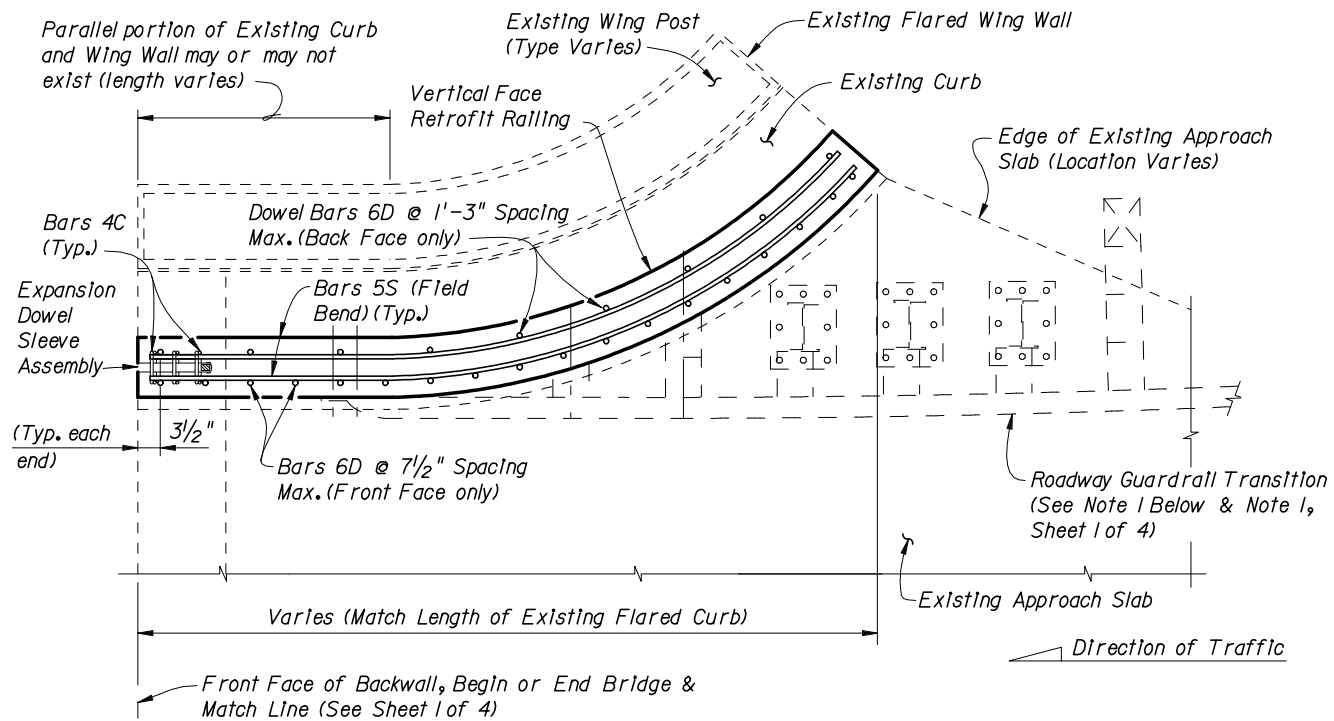

**PARTIAL PLAN OF RAILING**

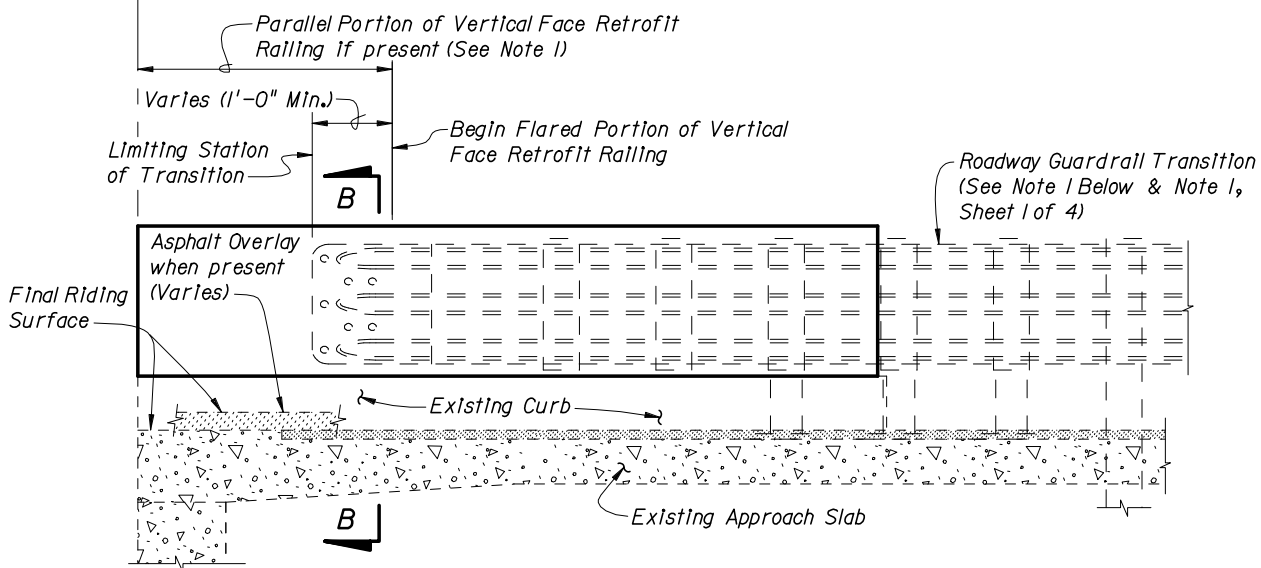

**PARTIAL ELEVATION OF INSIDE FACE OF RAILING**  
(Existing Wing Post, Railing Reinforcing and Expansion Dowel Assemblies not shown for clarity)

**SCHEME 3**  
**RAILING END TREATMENT FOR FLARED CURBS**

SCHEME 3 NOTE:

1. See Roadway Plans for limiting station of Roadway Guardrail Transition or other site specific treatment. If limiting station of Roadway Guardrail Transition is along the Wing Wall, attach Thrie Beam Terminal Connector to railing as shown above. If limiting station of Roadway Guardrail Transition is on the bridge, see Index No. 482, Sheet 1 of 4.

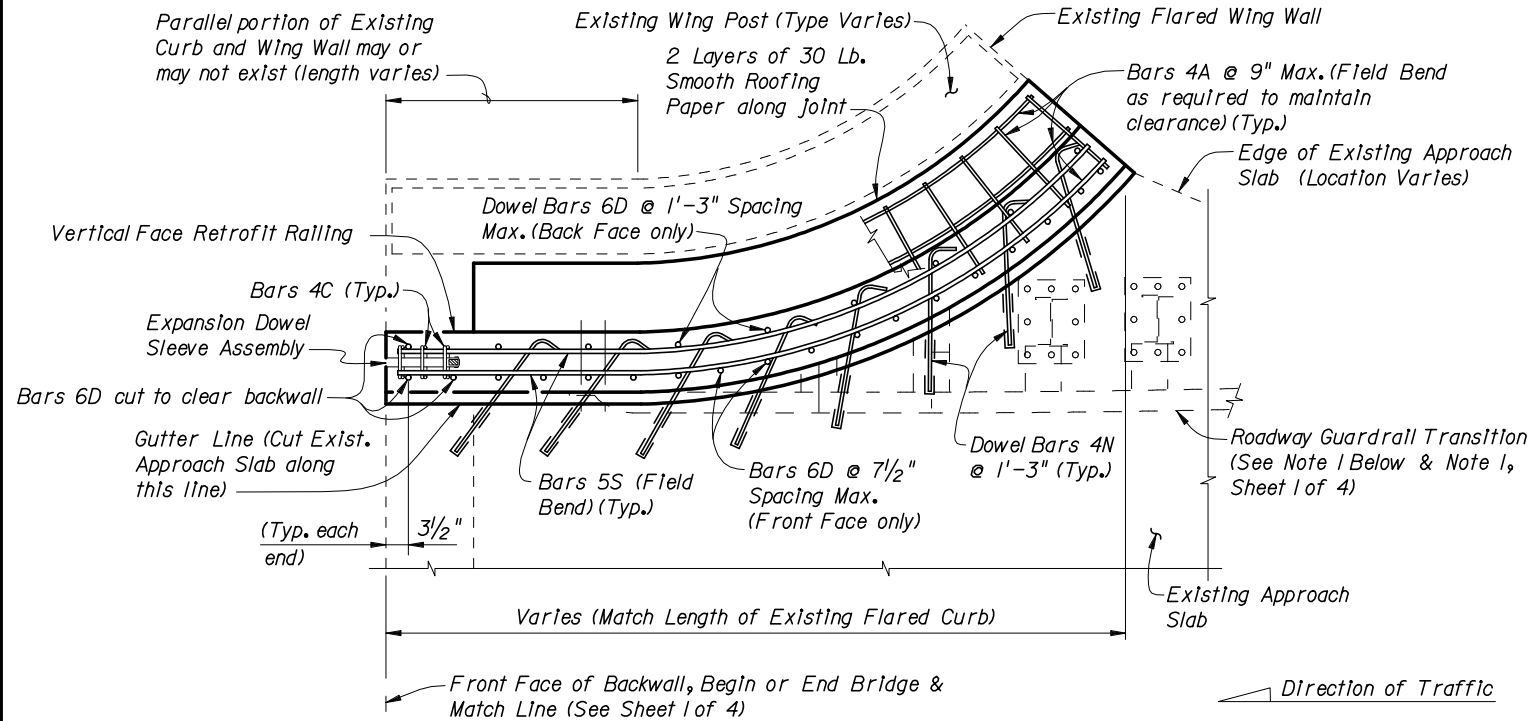

**PARTIAL PLAN OF RAILING**

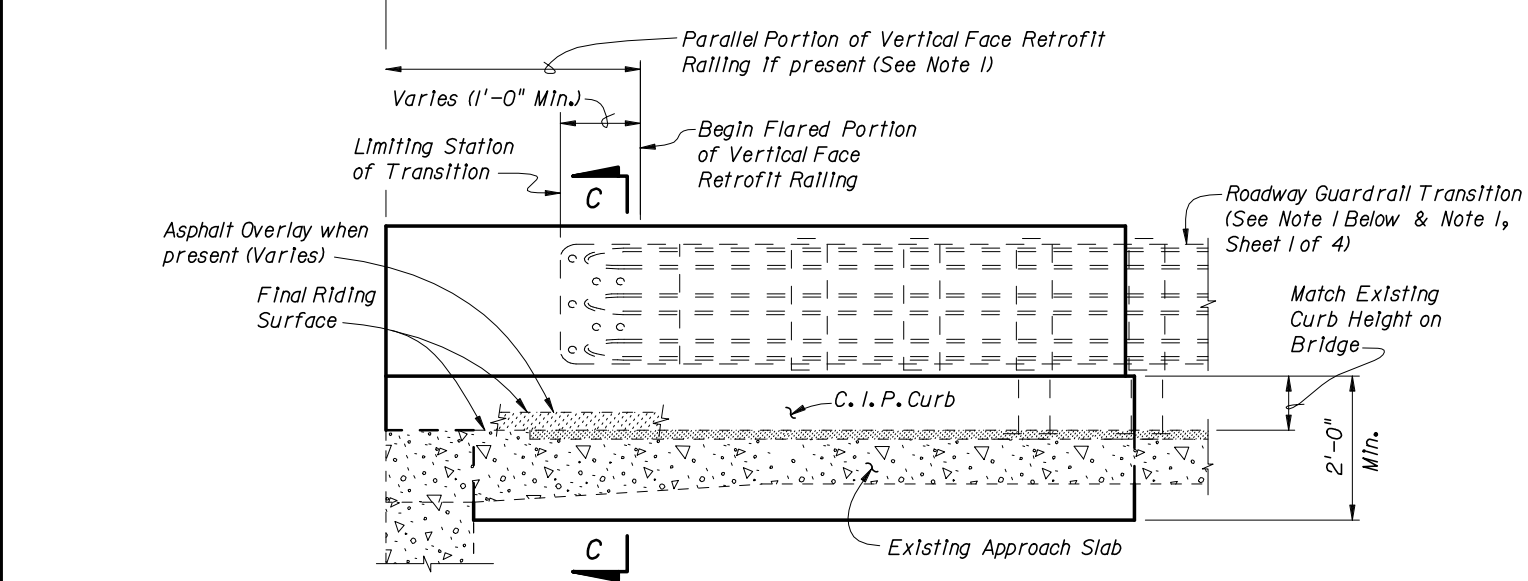

**PARTIAL ELEVATION OF INSIDE FACE OF RAILING**  
(Existing Wing Post, Railing Reinforcing and Expansion Dowel Assemblies not shown for clarity)

**SCHEME 4**  
**RAILING END TREATMENT FOR FLARED CURBS**

SCHEME 4 NOTES:

1. See Roadway Plans for limiting station of Roadway Guardrail Transition or other site specific treatment. If limiting station of Roadway Guardrail Transition is along the Wing Wall, attach Thrie Beam Terminal Connector to railing as shown above. If limiting station of Roadway Guardrail Transition is on the bridge, see Index No. 482, Sheet 1 of 4.
2. Dowel Bars 4N may be installed on a maximum angle of 45° to the cut edge of the Approach Slab as shown to facilitate drilling of holes and installation of bars.
3. At the Contractor's option, along the length of the Approach Slab curb that is to be replaced, Dowel Bars 6D may be cast in with the new section of curb as shown or they may be installed in drilled holes in the new section of curb using an Adhesive Bonding Material System with a 1'-0" minimum embedment.



2006 FDOT Design Standards

**TRAFFIC RAILING - (VERTICAL FACE RETROFIT)**  
**WIDE CURB**

Last Revision	Sheet No.
07/01/05	3 of 4
Index No.	
<b>482</b>	

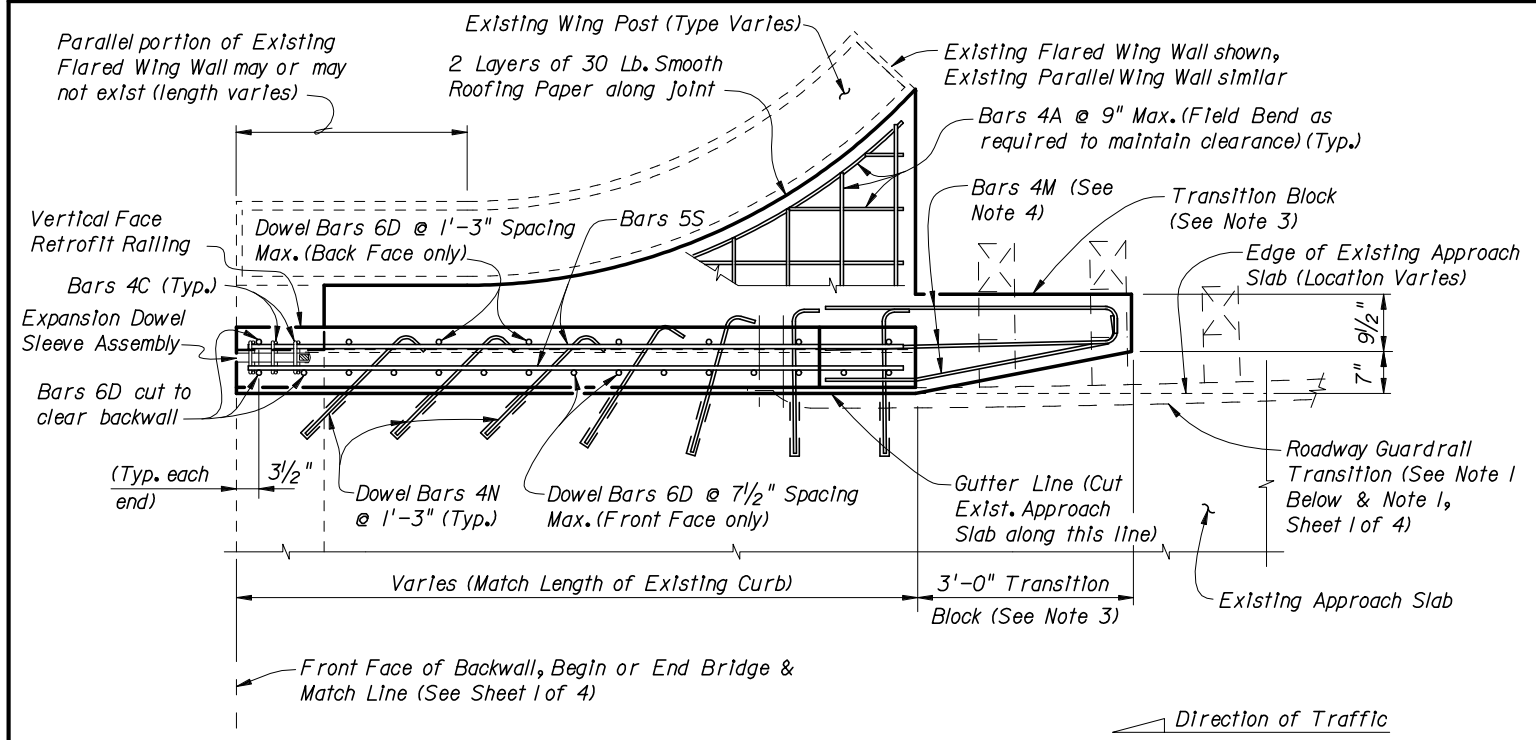

**PARTIAL PLAN OF RAILING**

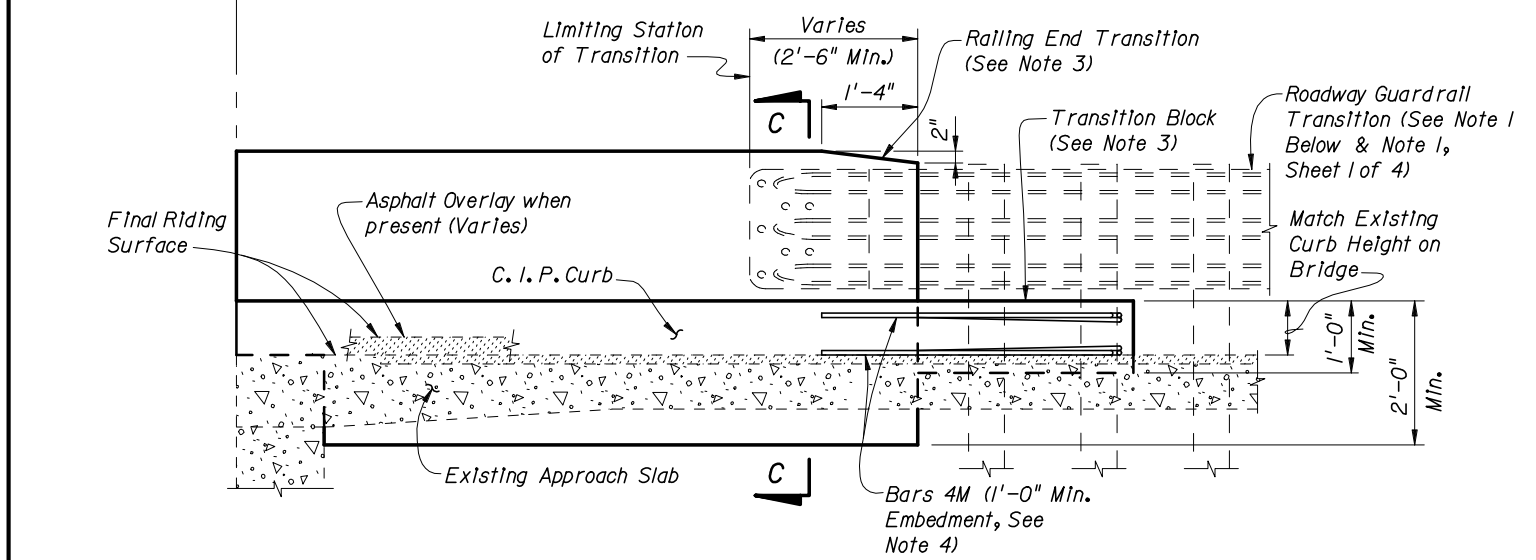

**PARTIAL ELEVATION OF INSIDE FACE OF RAILING  
(Existing Wing Post, Railing Reinforcing and Expansion Dowel Assemblies not shown for clarity)**

**SCHEME 5  
RAILING END TREATMENT FOR PARALLEL CURBS**

# Curb heights vary from 5" min. to 10" max. Match height and shape of existing curb on bridge.

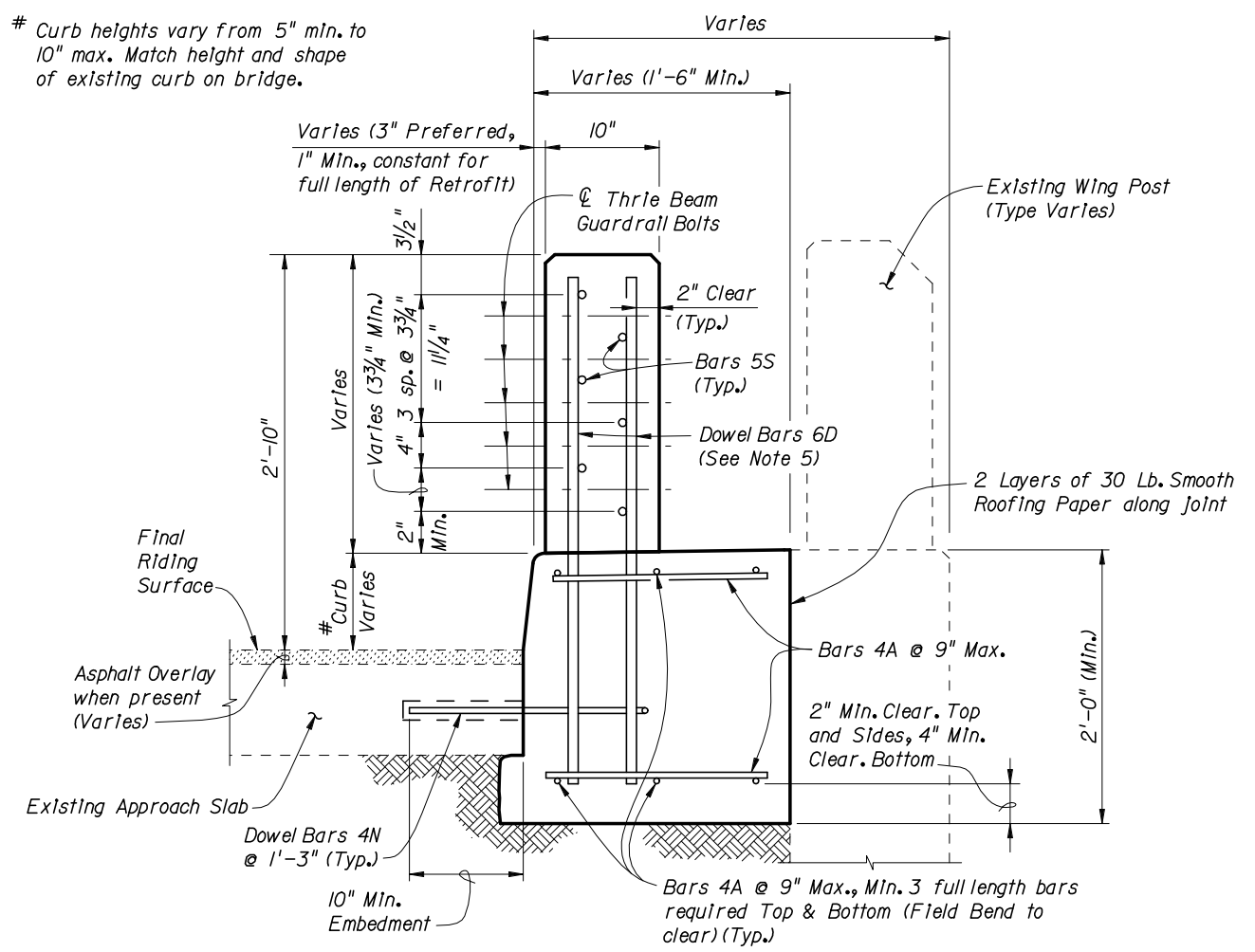

**SECTION C-C  
TYPICAL SECTION THRU RAILING ALONG APPROACH SLAB  
(SCHEME 4 SHOWN, SCHEME 5 SIMILAR)**

**SCHEME 5 NOTES:**

1. See Roadway Plans for limiting station of Roadway Guardrail Transition or other site specific treatment. If limiting station of Roadway Guardrail Transition is along the Wing Wall, attach Thrie Beam Terminal Connector to railing as shown above. If limiting station of Roadway Guardrail Transition is on the bridge, see Index No. 482, Sheet 1 of 4.
2. Dowel Bars 4N may be installed on a maximum angle of 45° to the cut edge of the Approach Slab as shown to facilitate drilling of holes and installation of bars.
3. Provide Transition Block (as shown) or Curb if existing Approach Slab Curb does not extend beyond end of existing End Bent Wing Wall, see Roadway Plans. Shape and height of Transition Block or Curb shall match existing bridge curb. Railing End Transition and Transition Block may be omitted on trailing ends with no opposing traffic.
4. Field bend Dowel Bars 4M within Transition Block as required to maintain 2" top and side clearance and 3" bottom clearance.
5. At the Contractor's option, along the length of the Approach Slab curb that is to be replaced, Dowel Bars 6D may be cast in with the new section of curb as shown or they may be installed in drilled holes in the new section of curb using an Adhesive Bonding Material System with a 1'-0" minimum embedment.