

FLARED END SECTION

SECTION BB

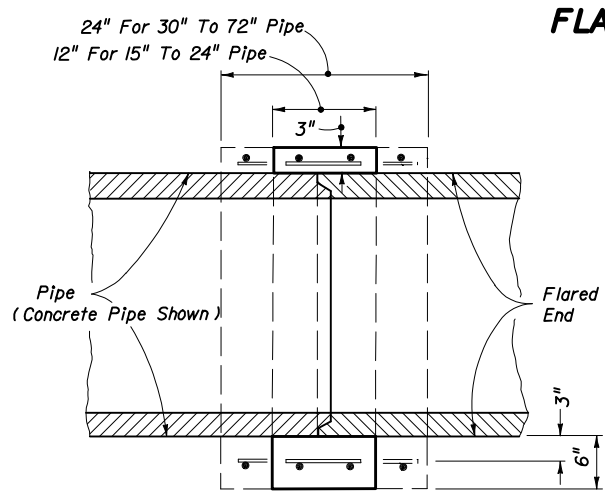

SECTION CC

REINFORCED CONCRETE JACKET DETAIL

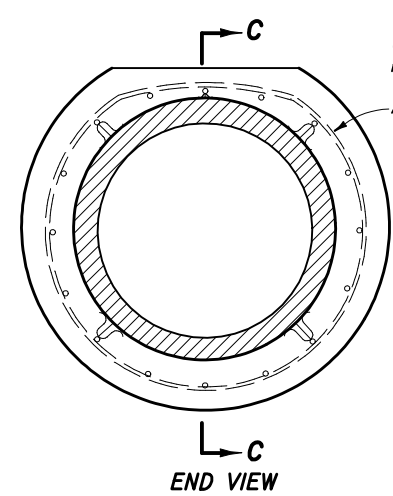

END VIEW

DIA.	T	REINF. REINF. SQ IN/LF	BELL OR SPIGOT	A	B	C	D	E	P	R 1	R 2	FLAT	WEIGHT (LBS.)	h	TOE WALL
															CLASS I CONC (Misc.) CY
12"	2"	0.07	1 1/2"	4"	2'-0"	4'-0 3/8"	6'-0 3/8"	2'-0"	19 5/8"	10 3/8"	9"	3 1/2"	530	12"	.06
15"	2 1/4"	0.07	2"	6"	2'-3"	3'-10"	6'-1"	2'-6"	24 5/16"	12 1/2"	11"	3 1/2"	740	12"	.07
18"	2 1/2"	0.07	2 1/2"	9"	2'-3"	3'-10"	6'-1"	3'-0"	29"	15 1/2"	12"	4"	990	15"	.11
21"	2 3/4"	0.07	2 1/2"	9"	2'-11"	3'-2"	6'-1"	3'-6"	31 3/8"	16 3/8"	13"	4"	1280	15"	.12
24"	3"	0.07	2 1/2"	9 1/2"	3'-7 1/2"	2'-6"	6'-1 1/2"	4'-0"	33 3/8"	16 3/8"	14"	4 1/2"	1520	18"	.17
27"	3 1/4"	0.148	2 1/2"	10 1/2"	4'-0"	2'-1 1/2"	6'-1 1/2"	4'-6"	36"	18 3/8"	14 1/2"	4 1/2"	1930	18"	.19
30"	3 1/2"	0.148	3"	1'-0"	4'-6"	1'-7 3/4"	6'-1 1/2"	5'-0"	37"	18 1/2"	15"	5"	2190	21"	.24
36"	4"	0.148	3 1/2"	1'-3"	5'-3"	2'-10 3/4"	8'-1 3/4"	6'-0"	47 13/16"	24 5/8"	20"	5 1/2"	4100	21"	.29
42"	4 1/2"	0.148	3 3/4"	1'-9"	5'-3"	2'-11"	8'-2"	6'-6"	53 1/4"	27 1/2"	22"	5 1/2"	5380	24"	.36
48"	5"	0.148	4 1/4"	2'-0"	6'-0"	2'-2"	8'-2"	7'-0"	56 1/2"	28 1/2"	22"	5 3/4"	6550	24"	.39
54"	5 1/2"	0.174	4 3/4"	2'-3"	5'-5"	2'-11"	8'-4"	7'-6"	65 1/2"	33 1/2"	24"	6 1/4"	8040	24"	.42
60"	6"	0.174	5"	2'-6"	5'-0"	3'-3"	8'-3"	8'-0"	72 1/2"	36 1/16"	24"	6 3/4"	8750	24"	.44
66"	6 1/2"	0.174	5 1/2"	2'-0"	6'-6"	1'-9"	8'-3"	8'-6"	72"	36 1/8"	24"	7 1/4"	10630	24"	.47
72"	7"	0.174	6"	2'-0"	6'-6"	1'-9"	8'-3"	9'-0"	77 13/16"	38 1/8"	24"	7 3/4"	12520	24"	.50

GENERAL NOTES

- Flared end sections shall conform to the requirements of ASTM C76 with the exception that dimensions and reinforcement shall be as prescribed in the table above. Circumferential reinforcement may consist of either one cage or two cages of steel. Compressive strength of concrete shall be 4000 psi. Shop drawings for flared end sections having dimensions other than above must be submitted for approval to the State Drainage Engineer.
- Connections between the flared end section and the pipe culvert may be any of the following types unless otherwise shown on the plans.
 - Joints meeting the requirements of Section 941-1.5 of the Standard Specifications (O-Ring Gasket). Flared end section joint dimensions and tolerances shall be identical or compatible to those used in the pipe culvert joint. When pipe culvert and flared end section manufacturers are different, the compatibility of joint designs shall be certified to by the manufacturer of the flared end sections.
 - Joints sealed with preformed plastic gaskets. The gaskets shall meet the requirements of Section 942-2 of the Standard Specifications and the minimum sizes for gaskets shall be as that specified for equivalent sizes of elliptical pipe.
 - Reinforced concrete jackets, as detailed on this drawing. Cost of the reinforced concrete jacket to be included in the contract unit price for the flared end section. When non-coated corrugated metal pipe is called for in the plans, the pipe shall be bituminous coated in the jacketed area as specified on Index No. 280. Bituminous coating to be included in the contract unit price for the pipe culvert. Concrete jacket shall be as specified on Index No. 280. Cost of concrete and reinforcement shall be included in the contract unit price for the pipe culvert.
- Toe walls shall be constructed when shown on the plans or at locations designated by the Engineer. Toe walls are to be cast-in-place with Class I Concrete and paid for under the contract unit price for Class I Concrete (Miscellaneous), CY. Reinforcing steel to be included in cost of toe wall.
- On skewed pipe culverts the flared end sections shall be placed in line with the pipe culvert. Side slopes shall be warped as required to fit the flared end sections.
- Flared End Section to be paid for under the contract unit price for Flared End Section (Concrete), Each. Sodding shall be in accordance with Index No. 281, and paid for under the contract unit price for Sodding, SY.

DESIGN NOTES

- Flared end sections are intended for use outside the clear zone on median drain and cross drain installation, except that flared end sections for pipe sizes 12" and 15" are permitted within the clear zone. When the slope intersection permits, 12" and 15" flared end sections may be located with the culvert opening as close as 8' beyond the outside edge of the shoulder. Flared end sections are not intended for side drain installations.
- Reinforced concrete jackets shall be used at all locations where high velocities and/or highly erosive soils may cause disjuncting. These locations are to be shown on the plans.
- Toe walls shall be used whenever the anticipated velocity of discharge and soil type are such that erosive action would occur. Toe walls are not required where ditch pavement is provided, except when disjuncting would occur if the ditch pavement should fail.