

Main Bars 5" x 1/4"
Cross Bars: Either 3/8" ∅ Electroforged Or 1/2" ∅ Welded

PLAN

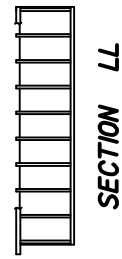

SECTION LL

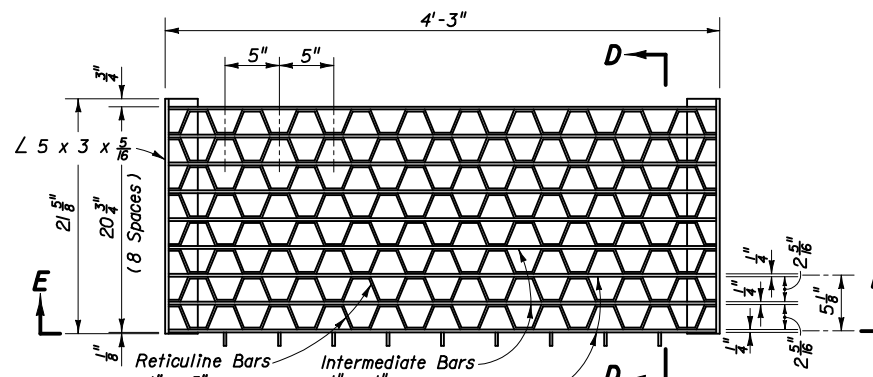

Reticuline Bars 1 1/4" x 3/8"
Intermediate Bars 1 1/2" x 1/4"
Bearing Bars 5" x 1/4"

PLAN

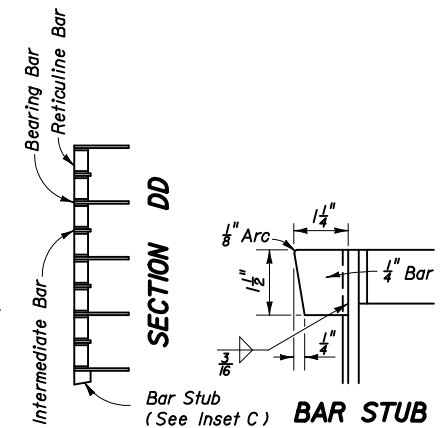

SECTION DD

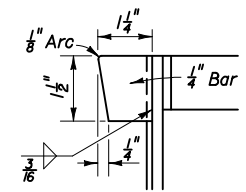

BAR STUB (See Inset C)

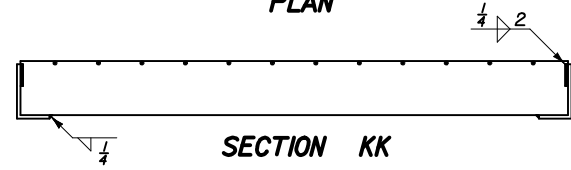

SECTION KK

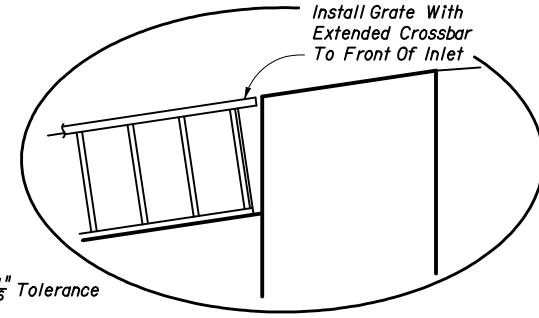

INSET B

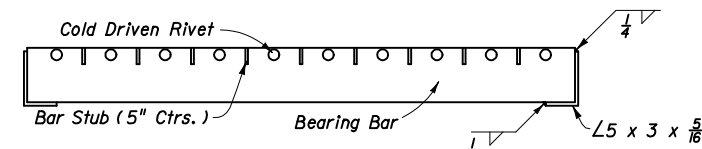

SECTION EE

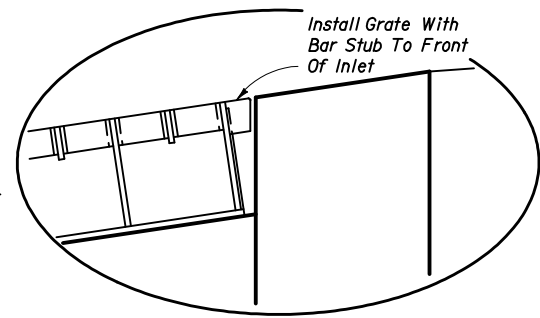

INSET C

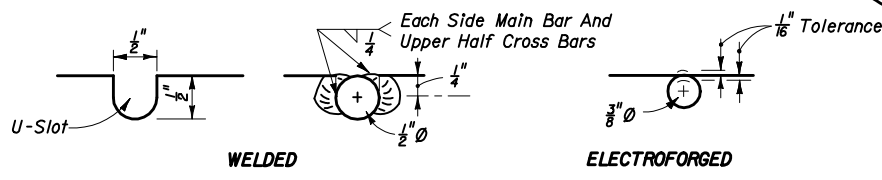

CROSS BAR OPTIONS

CROSS BAR

OPTIONAL STEEL GRATES

RETICULINE

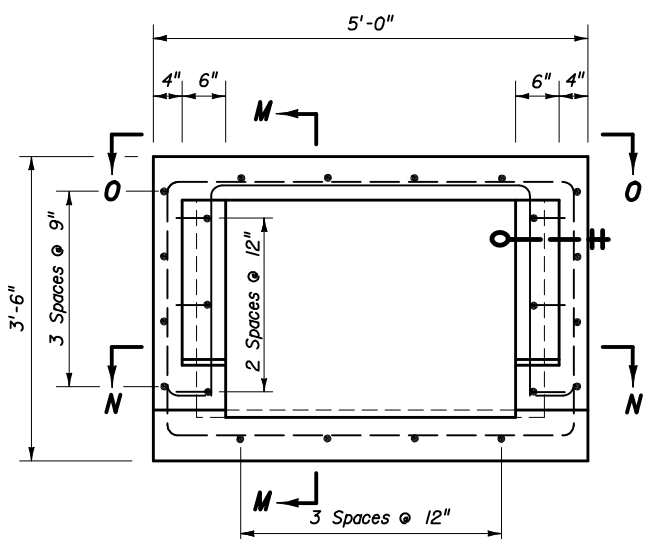

TOP VIEW OF INLET COLLAR WITHOUT GRATE

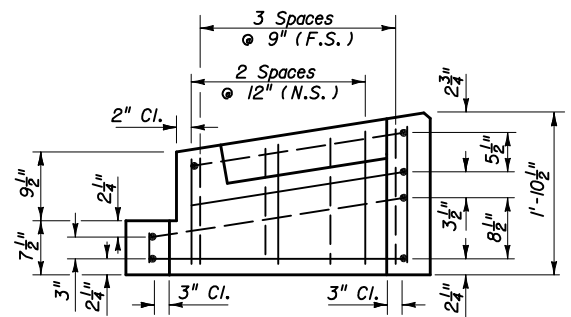

SECTION MM

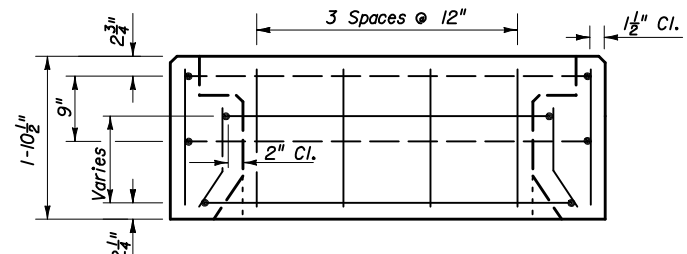

VIEW OO

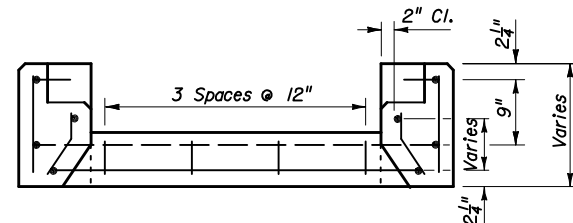

SECTION NN

PRECAST COLLAR REINFORCING DETAILS
(CAST-IN-PLACE COLLAR REINFORCING SIMILAR)

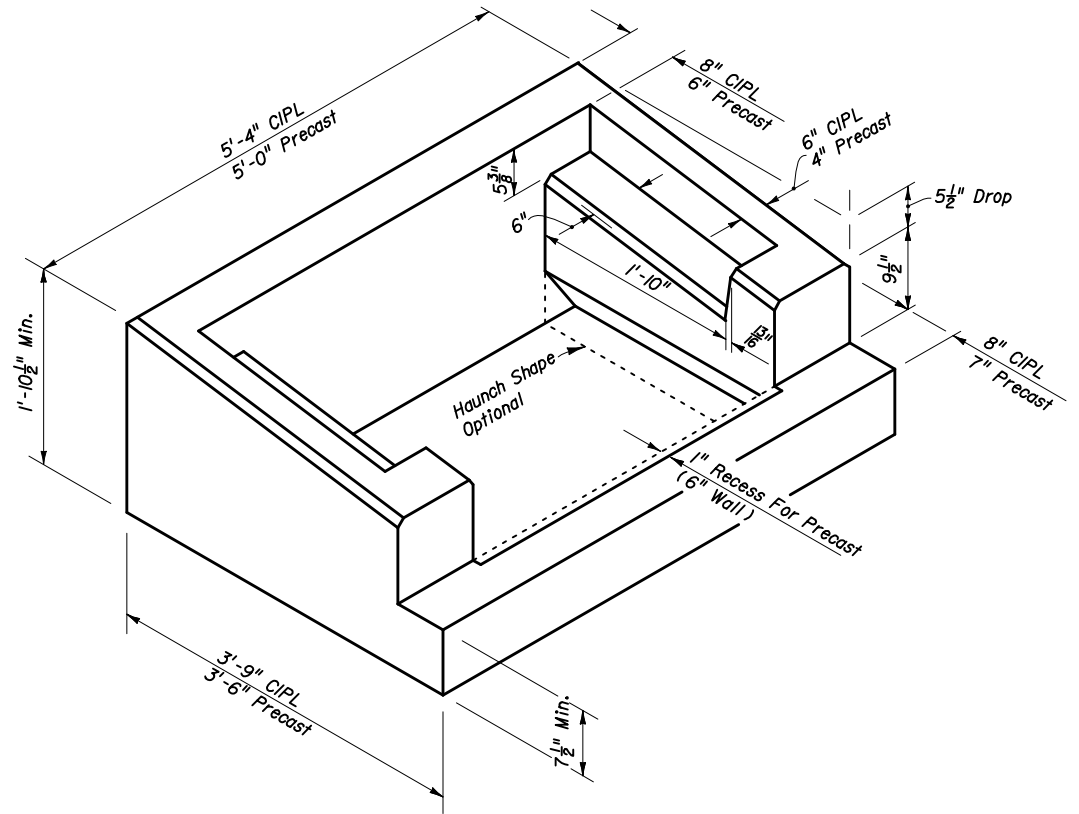

PICTORIAL VIEW OF INLET COLLAR

