

**GRATE SLOPE & DROP HEIGHT**

Shoulder Slope	Grate Slope Rate	Drop Height		Remarks
		CIPL	Precast	
0.03	1:6	1 $\frac{9}{16}$ "	1 $\frac{5}{16}$ "	Std. Med. Conc. Shldr.
0.05	1:6	1 $\frac{1}{16}$ "	7 $\frac{7}{8}$ "	Std. Med. Flex. Shldr.
0.06	1:6	1 $\frac{5}{16}$ "	5 $\frac{5}{8}$ "	
0.07	1:5	1 $\frac{5}{8}$ "	1 $\frac{3}{8}$ "	
0.08	1:5	1 $\frac{3}{8}$ "	1 $\frac{3}{16}$ "	
0.09	1:5	1 $\frac{1}{8}$ "	1 $\frac{5}{16}$ "	
0.10	1:5	7 $\frac{7}{8}$ "	1 $\frac{1}{16}$ "	e (max)

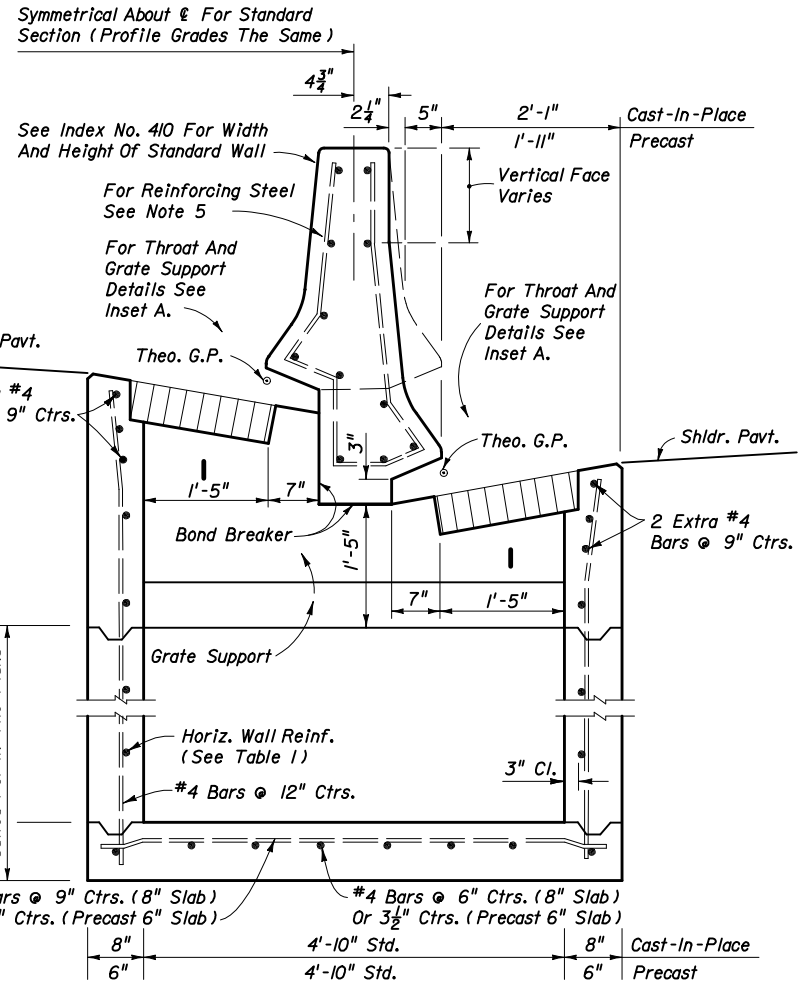
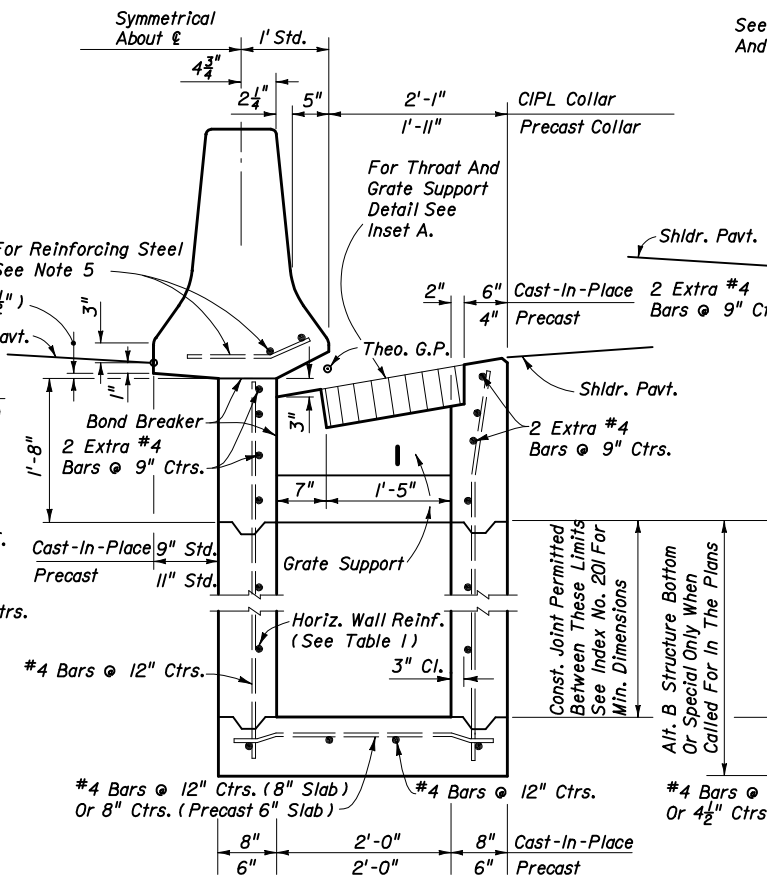
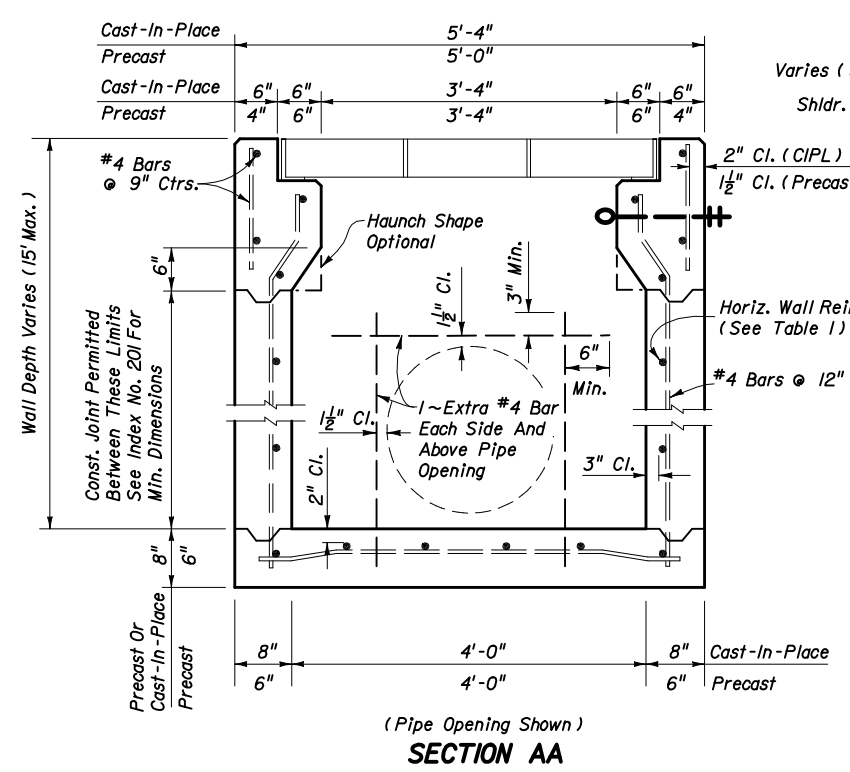
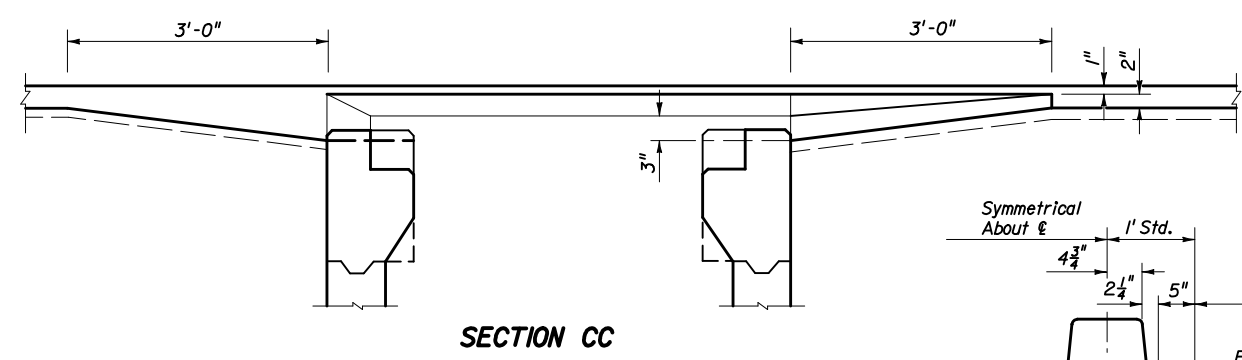
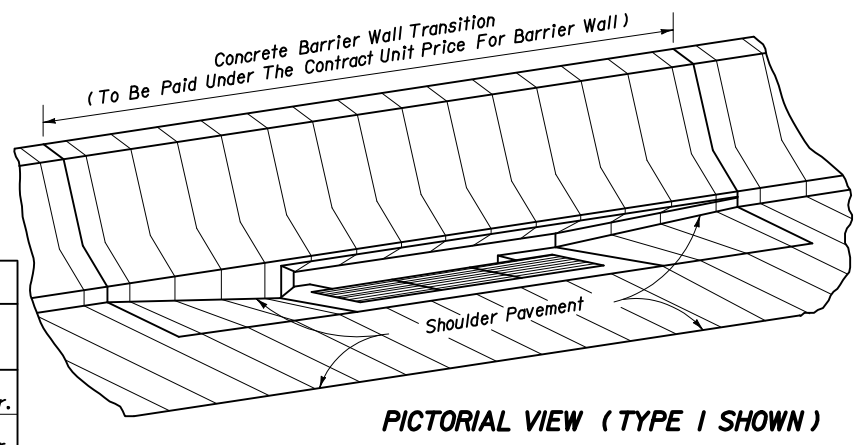

- GENERAL NOTES**
- Inlet Descriptions:  
 Type 1 Single throat, one side of barrier wall.  
 Type 2 Double throats, one side of barrier wall.  
 Type 3 Two single throats, opposite sides of barrier wall.  
 Type 4 Two double throats, opposite sides of barrier wall.  
 Type 5 Double throats, one side of barrier wall, and single throat other side of barrier wall.
  - For grate details see Index No. 220. The parallel bar grate shall be used unless the reticulate grate is called for in the plans. The reticulate grate shall be specified where bicycle traffic is anticipated. Not suitable for pedestrian traffic.
  - For standard concrete barrier wall dimensions, and for dimensions of concrete barrier wall incorporating light standards within the wall, see Index No. 410.
  - Reinforcing steel shall have 2" minimum cover. Horizontal wall reinforcing must be positioned 3" from the inside face unless otherwise shown.
  - All reinforcing Grade 60 #4 bars. See Index No. 201 for equivalent area of welded wire fabric for inlet. Longitudinal steel bars extend over full length of concrete barrier wall transition. Tie bars @ 12" ctrs. Reinforcing to be paid for under the contract unit price for Concrete Barrier Wall, LF.
  - For supplemental details see Index No. 201.
  - All dimensions are for both precast and cast-in-place inlets unless otherwise noted.
  - Inlets to be paid for under the contract unit price for Inlets (Median Barrier Type...), EA. Barrier wall to be paid for under the contract unit price for Concrete Barrier Wall, LF.

**HORIZONTAL WALL REINFORCING SCHEDULE (TABLE 1)**

WALL DEPTH	SCHEDULE	AREA (In <sup>2</sup> /ft)	MAX. SPACING	
			BARS	WWF
0' - 3'	A12	0.20	12"	8"
3' - 6'	A6	0.20	6"	5"
6' - 9'	B5.5	0.24	5 $\frac{1}{2}$ "	5"
9' - 15'	C6.5	0.37	6 $\frac{1}{2}$ "	6"

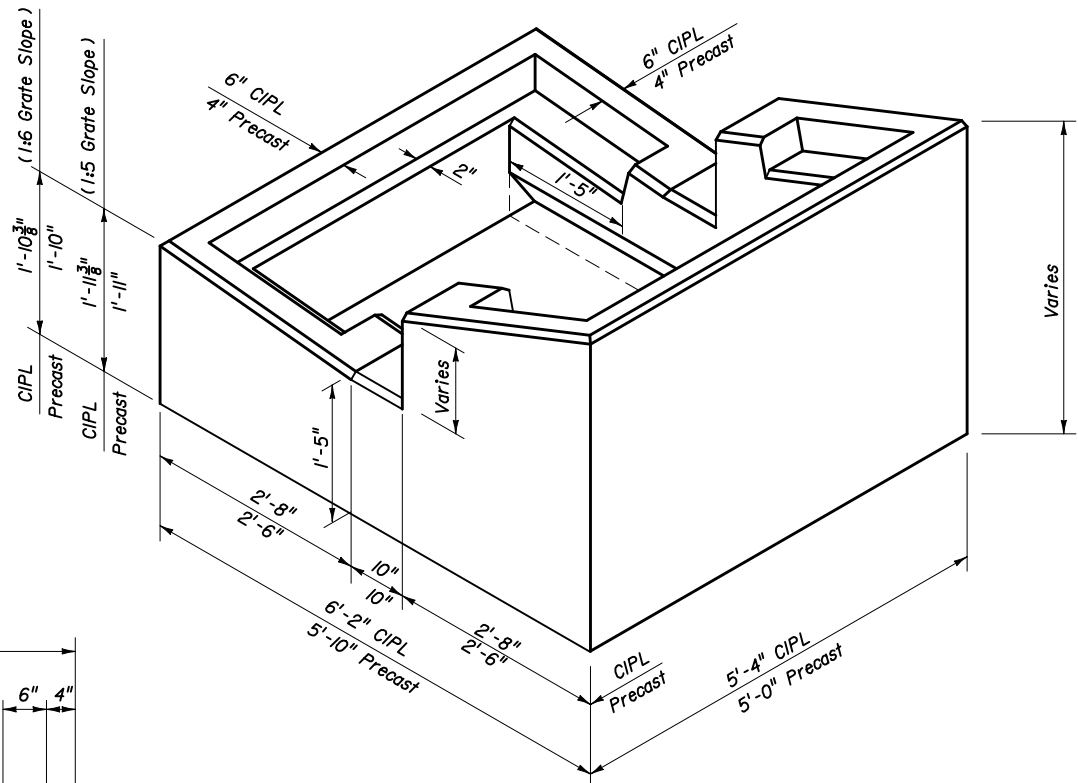

PICTORIAL VIEW OF INLET COLLAR (TYPES 3, 4, & 5)

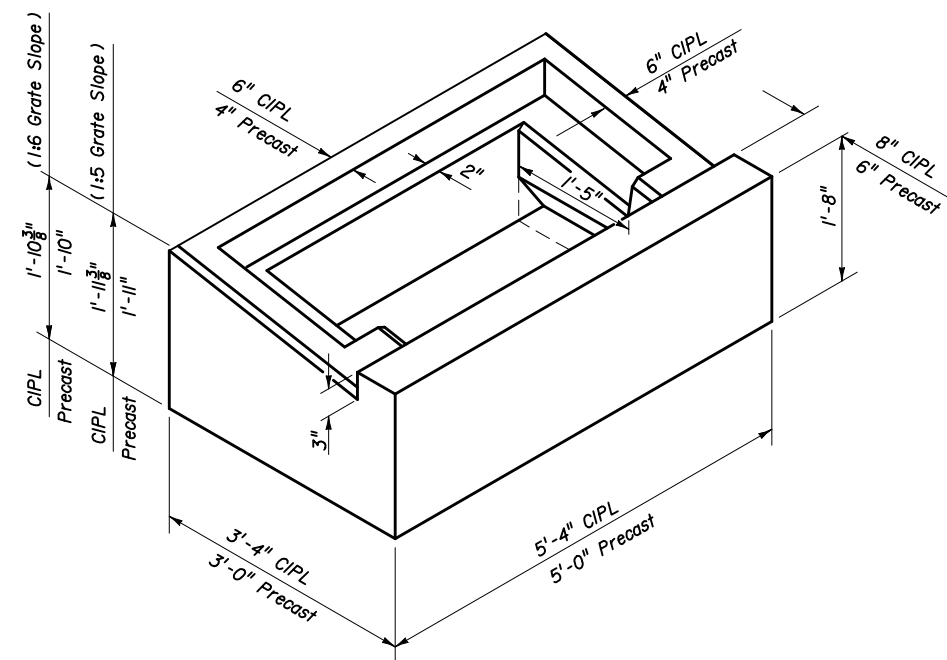

PICTORIAL VIEW OF INLET COLLAR (TYPES 1 & 2)

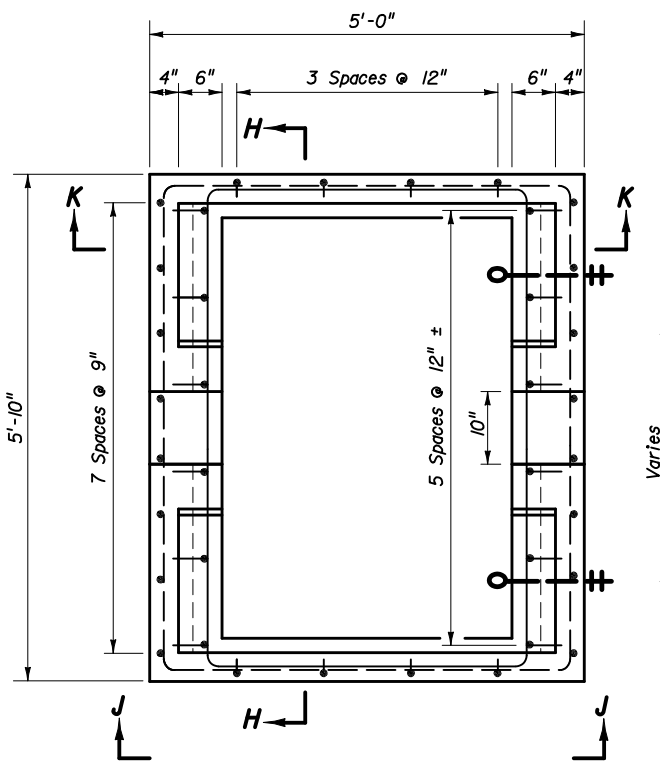

TOP VIEW OF INLET COLLAR WITHOUT GRATE

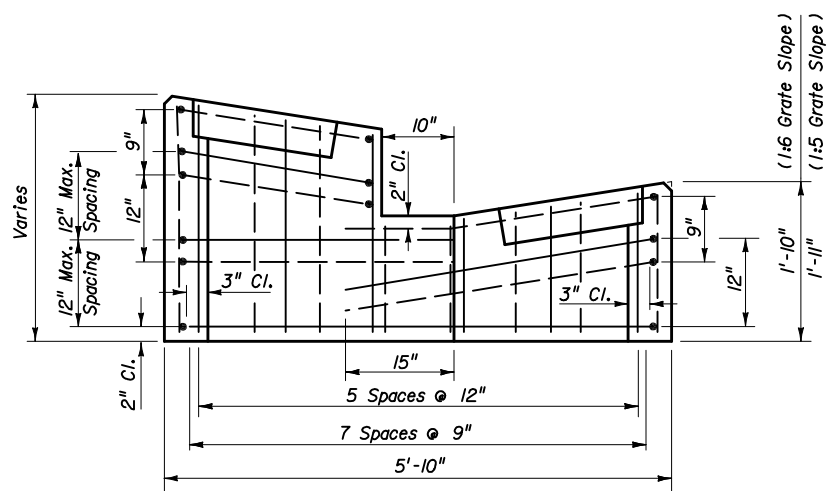

SECTION HH

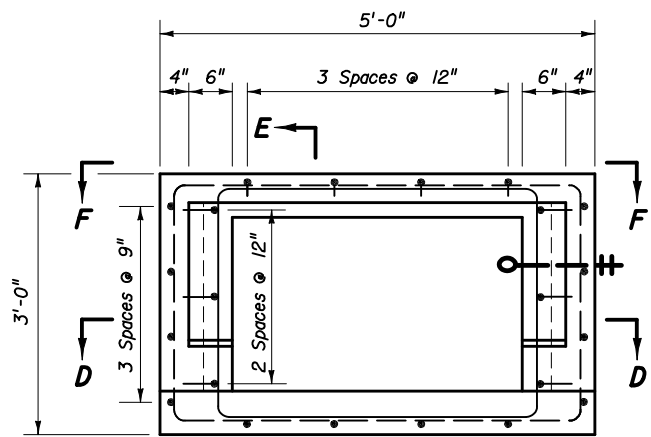

TOP VIEW OF INLET COLLAR WITHOUT GRATE

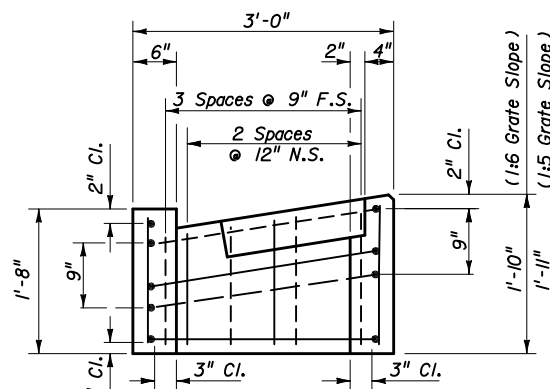

SECTION EE

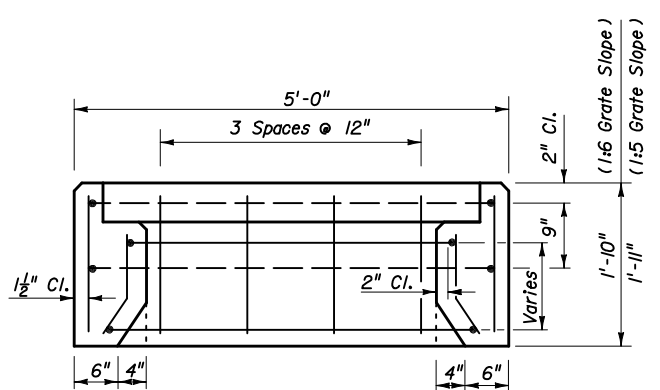

VIEW KK

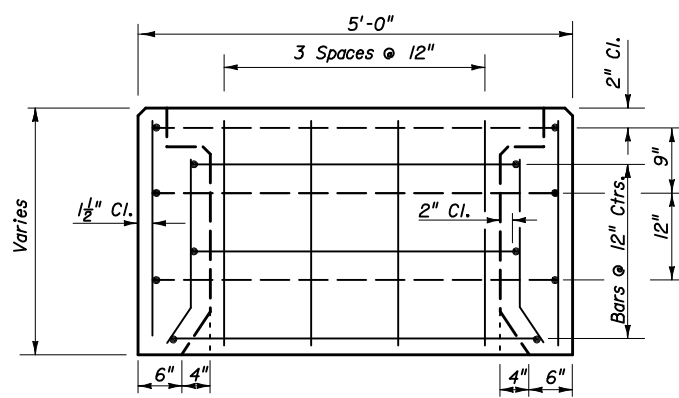

VIEW JJ

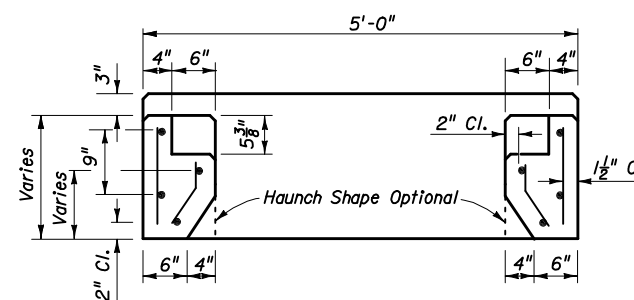

SECTION DD

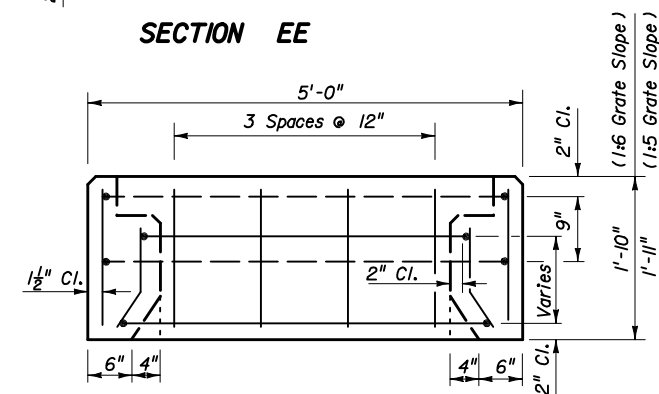

VIEW FF

PRECAST COLLAR REINFORCING DETAILS (TYPES 1 & 2)  
(CIPL COLLAR REINFORCING DETAILS SIMILAR)

PRECAST COLLAR REINFORCING DETAILS (TYPES 3, 4 & 5)  
(CIPL COLLAR REINFORCING DETAILS SIMILAR)

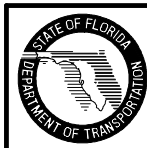

2006 FDOT Design Standards

MEDIAN BARRIER INLETS  
TYPES 1, 2, 3, 4 & 5

Last Revision	Sheet No.
07/01/05	2 of 2
Index No.	
217	