

- * Slip Forming Method of Construction is not allowed within the limits shown.
- ** For Index No. 820 - Pedestrian/Bicycle Railing, this dimension is 4 1/2". For all other Railings, this dimension is 2 Eq. Sp. @ 6" Max.
- *** Anchor Bolt pattern orientation shall be as shown.

PLAN VIEW

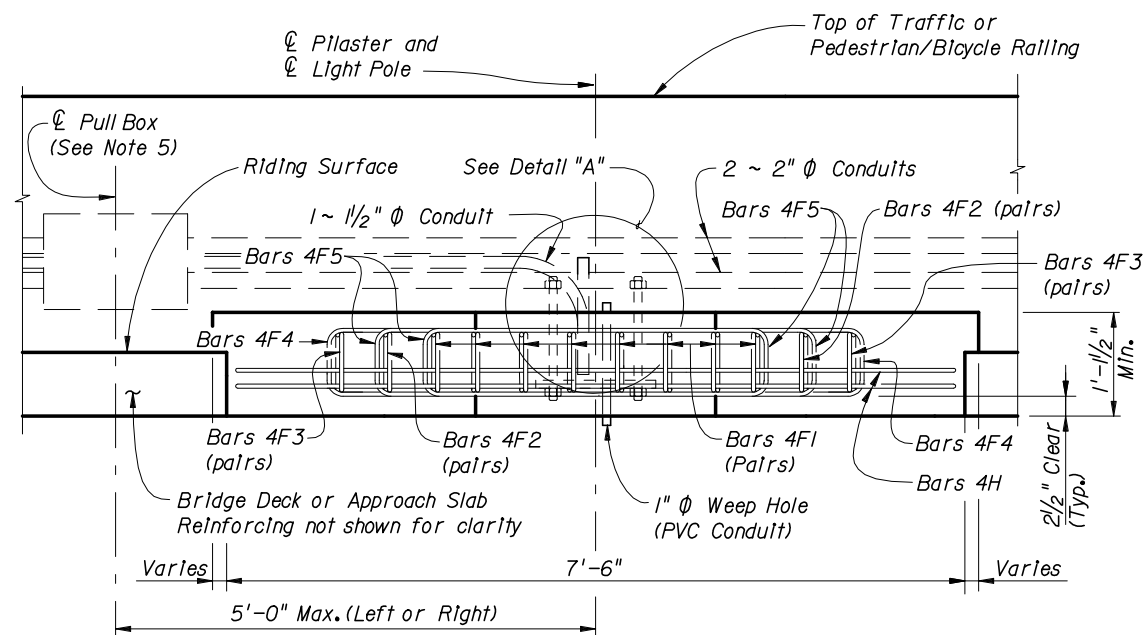

ELEVATION VIEW
(Bars 4G not shown for clarity)

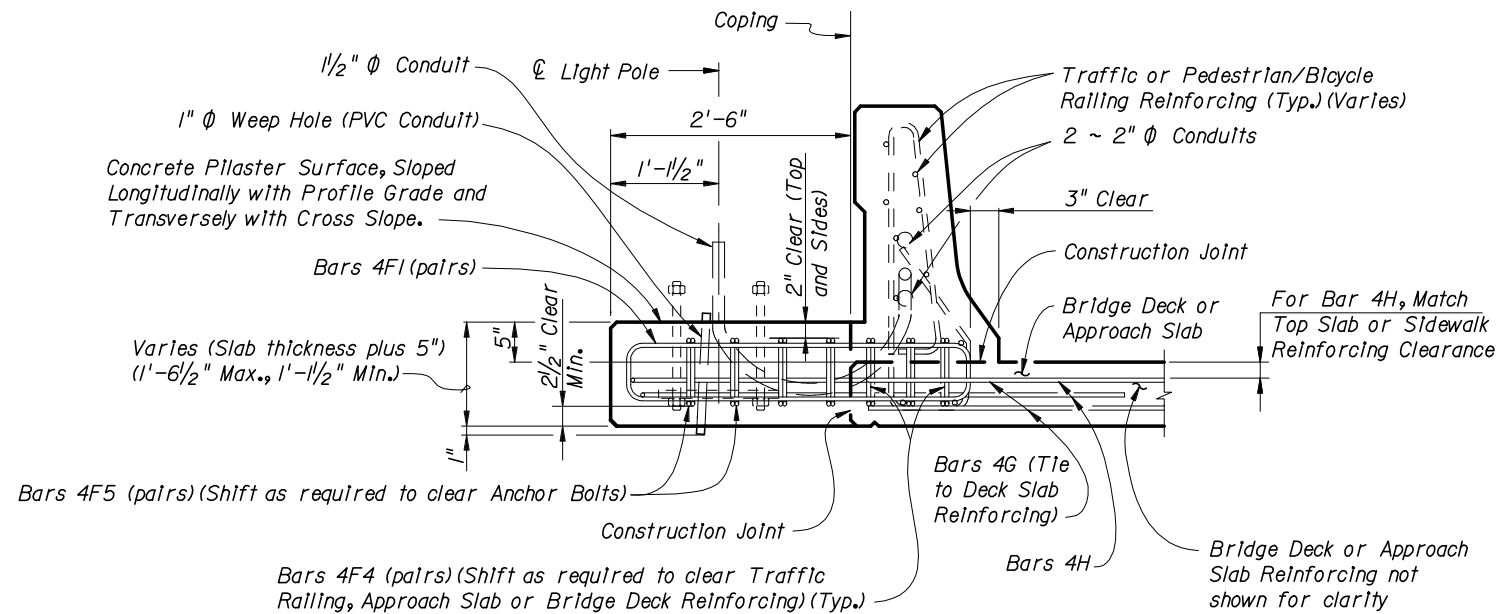

TYPICAL SECTION AT LIGHT POLE PILASTER FOR APPROACH SLAB OR BRIDGE DECK THICKNESS LESS THAN 1'-1/2".

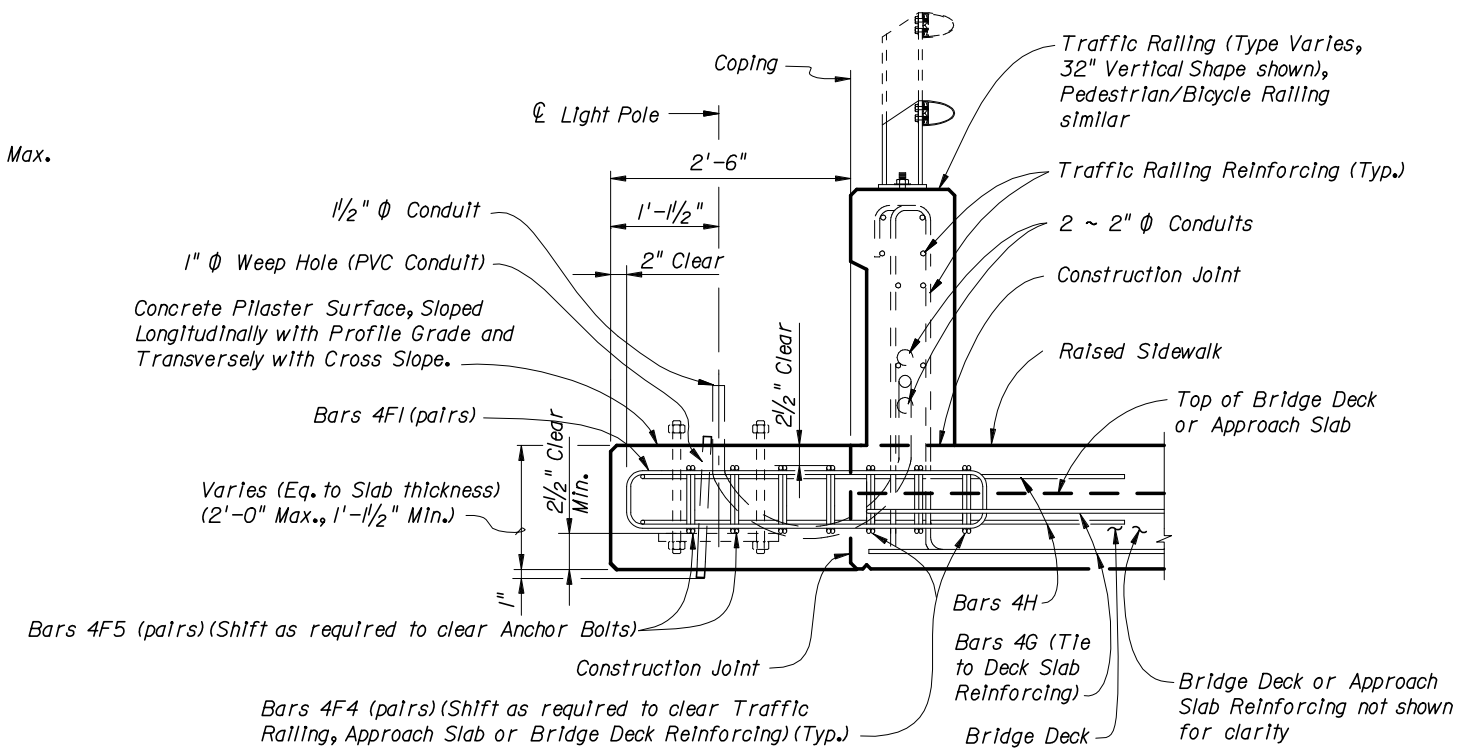

TYPICAL SECTION AT LIGHT POLE PILASTER FOR APPROACH SLAB OR BRIDGE DECK THICKNESS 1'-1/2" OR GREATER

CROSS REFERENCE:
For Detail "A" and Light Pole Pilaster Notes, see Sheet 2 of 2.

CONVENTIONAL REINFORCING STEEL BENDING DIAGRAMS

REINFORCING STEEL NOTES:

- a. When Pilaster is attached to Pedestrian/Bicycle Railing - Index No. 820 and the Bridge Deck or Approach Slab thickness is less than 1'-1/2", Bars 4F3 shall have leg length and bar length shown in parentheses.
- b. The number of bars shown in parentheses is for Bars 4F4 when Pilaster is attached to Pedestrian/Bicycle Railing - Index No. 820, and the Bridge Deck or Approach Slab thickness is less than 1'-1/2".
- c. Lap Splices for Bars 4F1, 4F2 & 4F3 shall be a minimum of 1'-4". Lap Splices for Bars 4F4 & 4F5 shall be minimum of 1'-8".
- d. All bar dimensions in the bending diagrams are out to out.

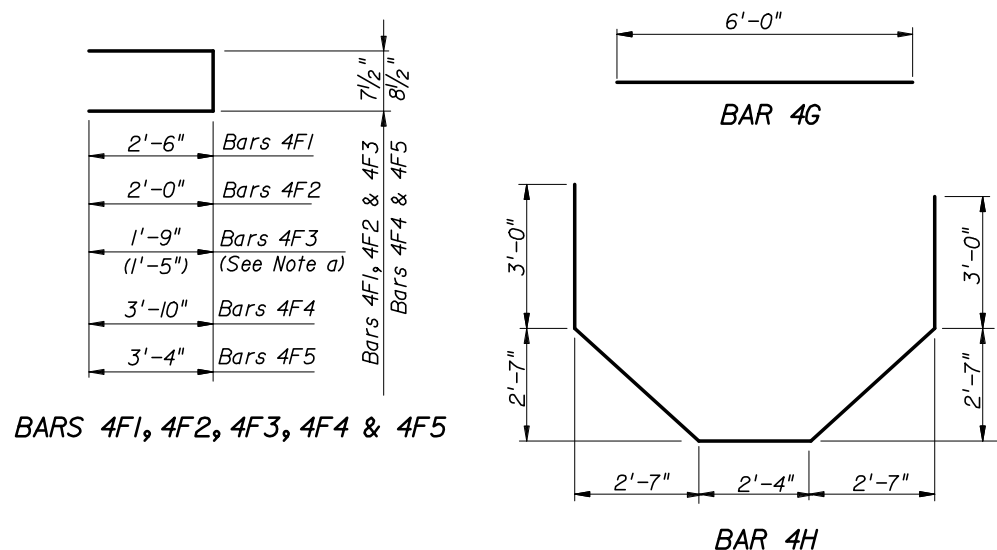

BILL OF REINFORCING STEEL

MARK	SIZE	NO. REQ'D	LENGTH	NOTES
F1	4	16	5'-8"	c
F2	4	4	4'-8"	c
F3	4	4	4'-2" (3'-6")	a, c
F4	4	10 (8)	8'-5"	b, c
F5	4	4	7'-5"	c
G	4	16	6'-0"	-
H	4	2	15'-8"	-

ESTIMATED LIGHT POLE PILASTER QUANTITIES PER LIGHT POLE PILASTER

ITEM	UNIT	QUANTITY
Concrete Per Pilaster Thickness	C.Y./IN.	0.040
Reinforcing Steel	LB.	244.16 (231.19)

(The Reinforcing Steel quantity shown in parentheses is for a Pilaster attached to Pedestrian/Bicycle Railing - Index No. 820 with Bridge Deck or Approach Slab thinner than 1'-1/2")

INSTRUCTIONS TO DESIGNER:

- In order to minimize vibration of Light Poles due to traffic, locate pilasters near substructure supports.
- Locate ϕ Pilaster minimum 3'-10" away from ϕ Traffic Railing Open Joint and edge of End Bent Wingwall.
- Design of the additional Bridge Deck Reinforcement is based on the minimum transverse top slab reinforcing required by Structures Design Guidelines.

CROSS REFERENCE:
For location of Detail "A" see Sheet 1 of 2.

LIGHT POLE PILASTER NOTES

1. Concrete and Reinforcing Steel required for the construction of the Pilaster shall meet the same requirements as the Traffic Railing or Pedestrian/Bicycle Railing the Pilaster is attached to. Grout shall comply with Specification Section 934.
2. Light Pole Pilaster may be used with the following:
 Index No. 420 - Traffic Railing (32" F Shape),
 Index No. 422 - Traffic Railing (42" Vertical Shape),
 Index No. 423 - Traffic Railing (32" Vertical Shape),
 Index No. 424 - Traffic Railing (Corral Shape),
 Index No. 425 - Traffic Railing (42" F Shape),
 Index No. 820 - Pedestrian/Bicycle Railing,
 Index No. 821 - Aluminum Pedestrian/Bicycle Bullet Railing for Traffic Railing (32" F Shape), or
 Index No. 5210 - Traffic Railing /Sound Barrier (Bridge).
 Unless otherwise noted, Traffic Railing (32" F Shape) is shown in all Views and Sections on Sheet 1 of 2. The Pilaster details for other Traffic Railings or Pedestrian/Bicycle Railing are similar.
3. The Pilaster and Deck are designed to resist the following Working Loads from the Light Pole applied at the top of the Pilaster:
 Axial Dead Load = 1.560 kip
 Wind Load Moment about Transverse Axis = 40.60 kip-ft
 Wind Load Moment about Longitudinal Axis = 28.30 kip-ft
 Deadload Moment about Longitudinal Axis = 1.690 kip-ft
 Maximum Shear = 1.380 kip
 Torsion about Pole Axis = 3.560 kip-ft
4. The Contractor is responsible for providing Anchor Bolts, Nuts, Washers and Anchor Plates that effectively transmit the Light Pole Loads to the Pilaster and fit the Reinforcing cage. Submit calculations for Anchor Bolt Design and Embedment Depth, Signed and Sealed by a Professional Engineer registered in the State of Florida to the Engineer for Review and Approval prior to Construction.
5. For Conduit, Pull Box, Expansion/Deflection Fitting and adjacent Reinforcing Steel Details, see Utility Conduit Detail Sheets.
6. Anchor Bolts must be installed plumb.
7. PAYMENT: The cost of Anchor Bolts, Nuts, Washers and Anchor Plates shall be included in the Bid Price for Light Poles. The cost of all Labor, Concrete and Reinforcing Steel required for the Construction of the Pilasters, Grout Pads, Pull Boxes, and Miscellaneous Hardware required for the completion of the Electrical System, shall be included in the Bid Price for the Traffic Railing or Pedestrian/Bicycle Railing the Pilaster is attached to.

