

(Steel Cover Shown)  
**SECTION AA**

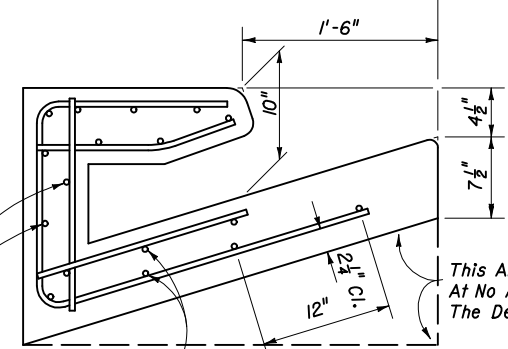

**SECTION PP**

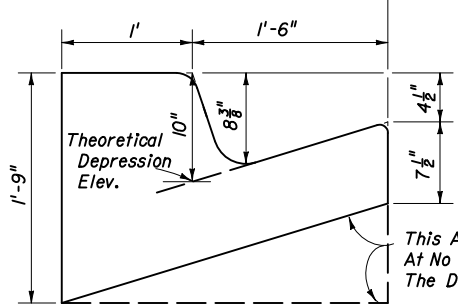

**SECTION QQ**

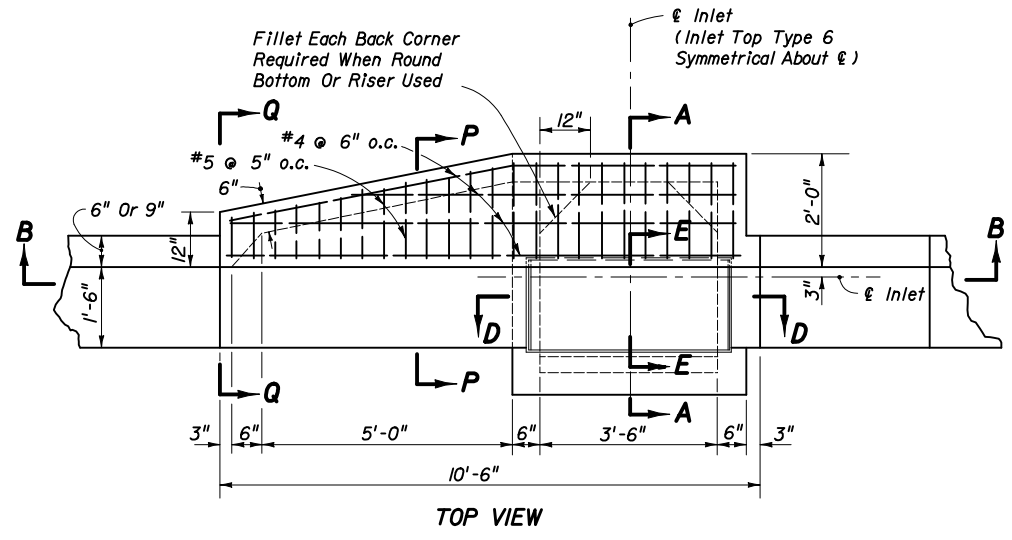

**TOP VIEW**

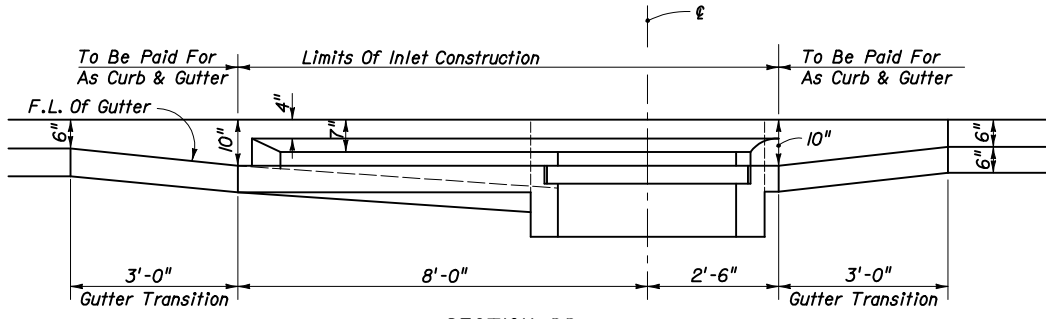

**SECTION BB**  
(Curb Inlet Top Type 6 Symmetrical With Left Half)

**INLET TYPE 5**

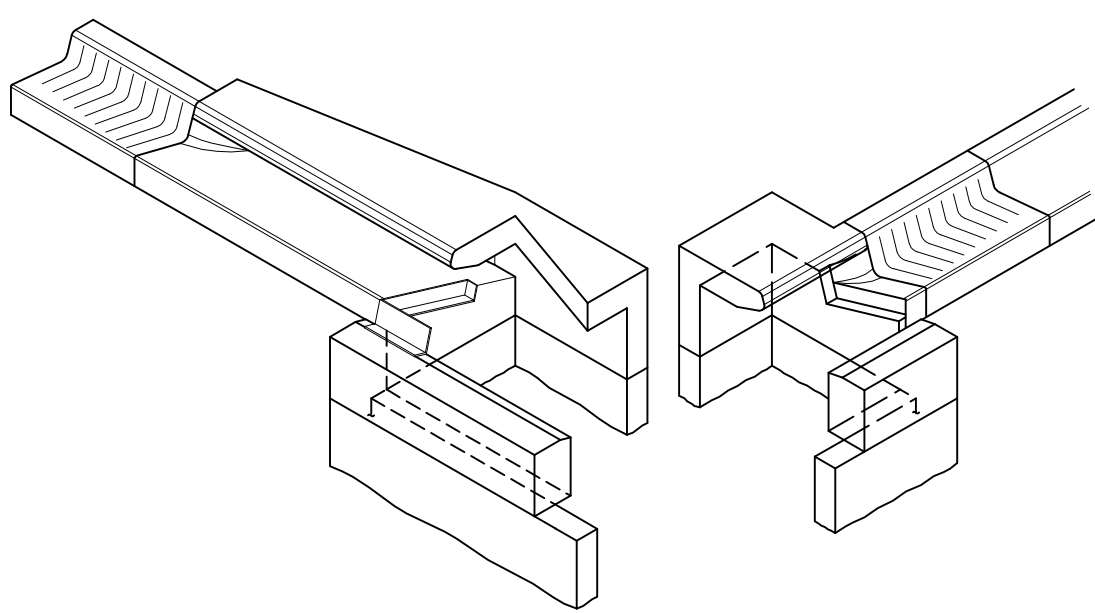

**SKETCH SHOWING FRAME SEAT AND THROAT RECESS**

**GENERAL NOTES**

- The finished grade and slope of the inlet tops are to conform with the finished cross slope and grade of the proposed sidewalk and/or border.
- When inlets are to be constructed on a curve, refer to the plans to determine the radius and, where necessary, modify the inlet details accordingly. Bend steel when necessary.
- All reinforcing steel shall have 1/4" minimum cover unless otherwise shown. Inlet tops shall be either cast-in-place or precast concrete.
- Precasting of this inlet top will be permitted. Precast units shall conform to the dimensions shown or in accordance with approved shop drawings. Request for shop drawing approval shall be directed to the State Drainage Engineer.
- Concrete meeting the requirements of ASTM C478 (4,000 P.S.I.) may be used in lieu of Class I concrete for precast units, manufactured in plants which are under the Standard Operating Procedures for the inspection of precast drainage products.
- The corner fillets shown for rectangular throats are necessary only when throats are to be used in conjunction with circular inlet bottoms or when used on skew with rectangular inlet boxes.
- For inlet bottoms see Index No. 200. 4' and larger bottoms are to be used with 3'-6" riser.
- These inlet tops are designed for use with standard curb and gutter Type E and Type F. Locate inlet outside of pedestrian crosswalks.
- See Index No. 201 for supplemental details.
- All steel used for frame and cover shall meet the requirements of ASTM A36/A36M.
- Either cast iron covers or steel covers may be used. Iron covers shall be Class No. 30 castings in accordance with ASTM A48.
- When Alternate "G" Cover is specified in plans either the cast iron cover and galvanized steel frame or the galvanized steel cover and frame must be used. Covers are to be grouted in accordance with the grouting detail shown on sheet 2 of 2, in lieu of tack welding.
- Inlet to be paid for under the contract unit price for Inlets (Curb) (Type \_\_\_), Each.

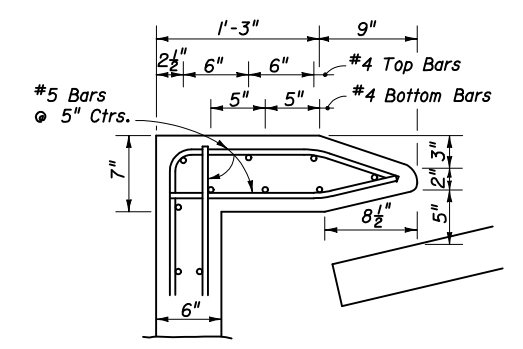

**TOP MODIFICATION FOR TYPE E CURB**



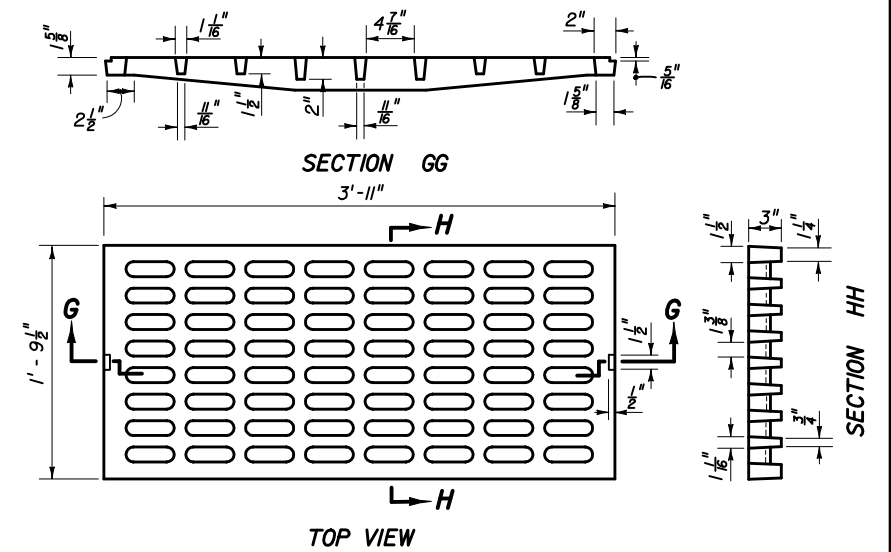
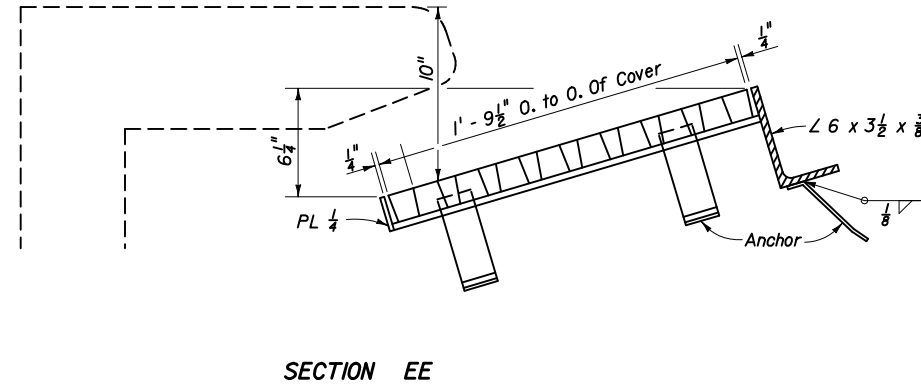
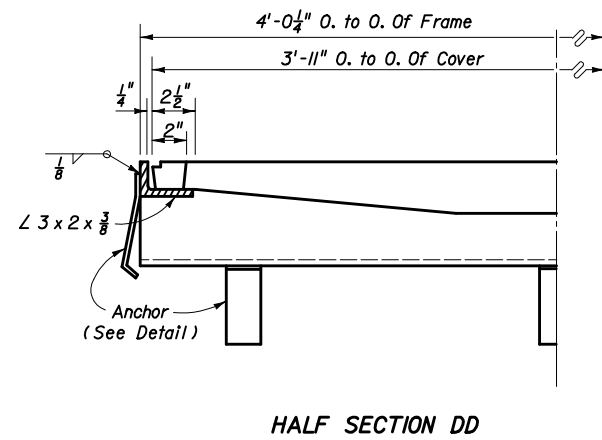
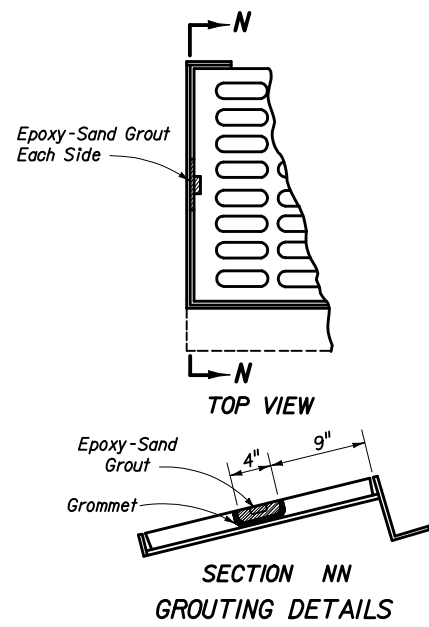

**CAST IRON COVER**

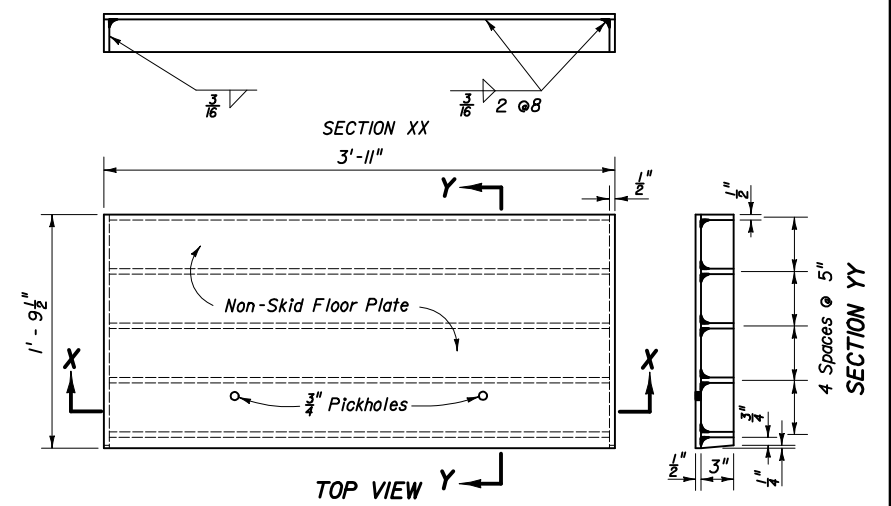
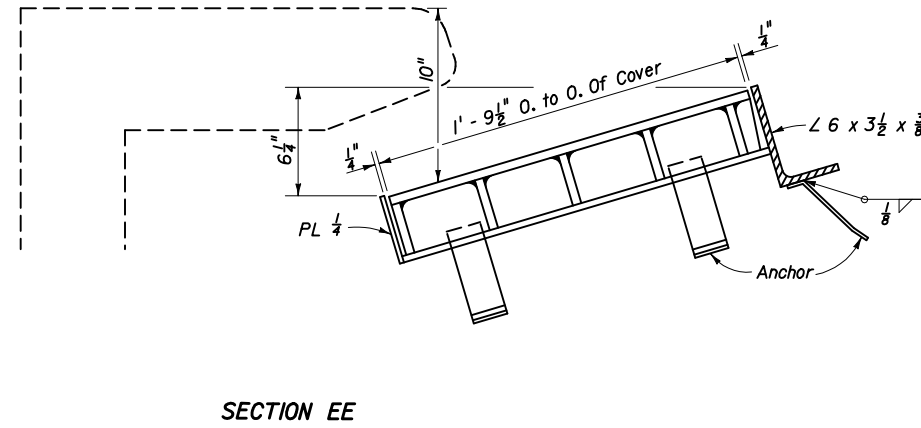
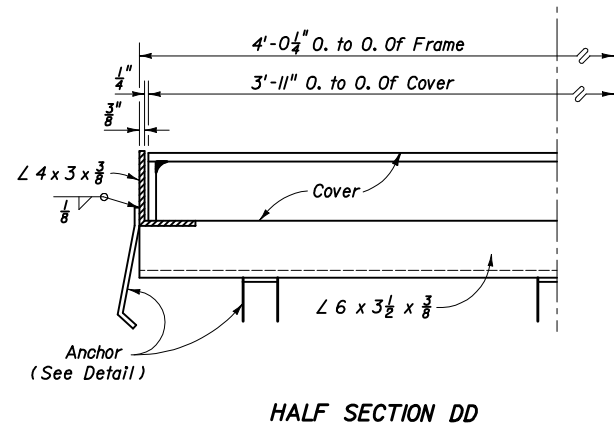
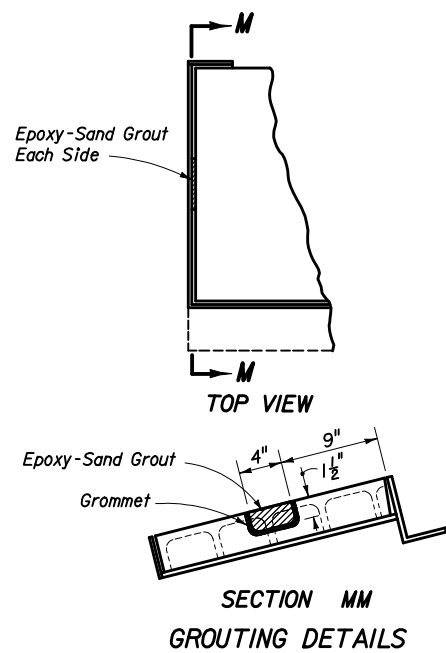

**STEEL COVER**

