

- GENERAL NOTES**
- SURFACE TREATMENT:** As an option to Class 4 Floor Finish (Bridge Floor Grooving) per Section 400 a hand tined or heavy broomed finish may be permitted on the concrete portion of the riding surface. Sidewalk areas shall receive a broomed finish. The top surface of the concrete beneath the asphalt overlay shall be raked.
 - UTILITIES:** If required, see Structures Plans, Utility Conduit Detail Sheets for details.
 - When a longitudinal construction joint is necessary or allowed by the Engineer, the transverse steel shall be extended as shown in the Longitudinal Construction Joint Detail.
 - The plan view for CASE 1 applies when the skew angle (ϕ) = 0°.
 - The plan view for CASE 2 applies where the skew angle (ϕ) is > 0°. The slab shown represents a skew to the right for an approach slab at begin bridge; approach slab at the end of bridge or a left skew shall be treated similarly.
 - Railings, parapets and traffic separators shall be provided as shown in Structures Plans. Payment for these items shall be included in the pay item for the required item. Raised sidewalks shall be provided as shown in the Structures Plans. Payment shall be included in the pay items for approach slab concrete and reinforcement. Welded Wire Fabric for the edge of Approach Slabs on retaining wall is not included in the estimated quantity for reinforcing steel and is considered incidental to the work. Welded Wire Fabric shall conform to ASTM A185.
 - ASPHALT OVERLAY:** Payment for asphalt overlay items is included in Roadway Pay Items. Continue the asphalt pavement over the approach slab and match the friction course type used on the roadway. For FC-5, place the final structural course 1.0" thick and the friction course 0.75" thick. For FC-9.5, place the final structural course 0.75" thick and the friction course 1.0" thick. For FC-12.5 (FC-6), place the friction course in one layer 1.75" thick.
 - Approach slabs shown in Plan View Cases 1 and 2 represent a typical approach slab with edge barriers and no sidewalks. See additional approach slab sheets for sidewalk and other pertinent details.

CROSS REFERENCES:
 For Section B-B, Longitudinal Construction Joint Detail and Approach Slab Details see Index No. 20900, Sheet 2 of 2.
 For Estimated Quantities see Structures Plans.

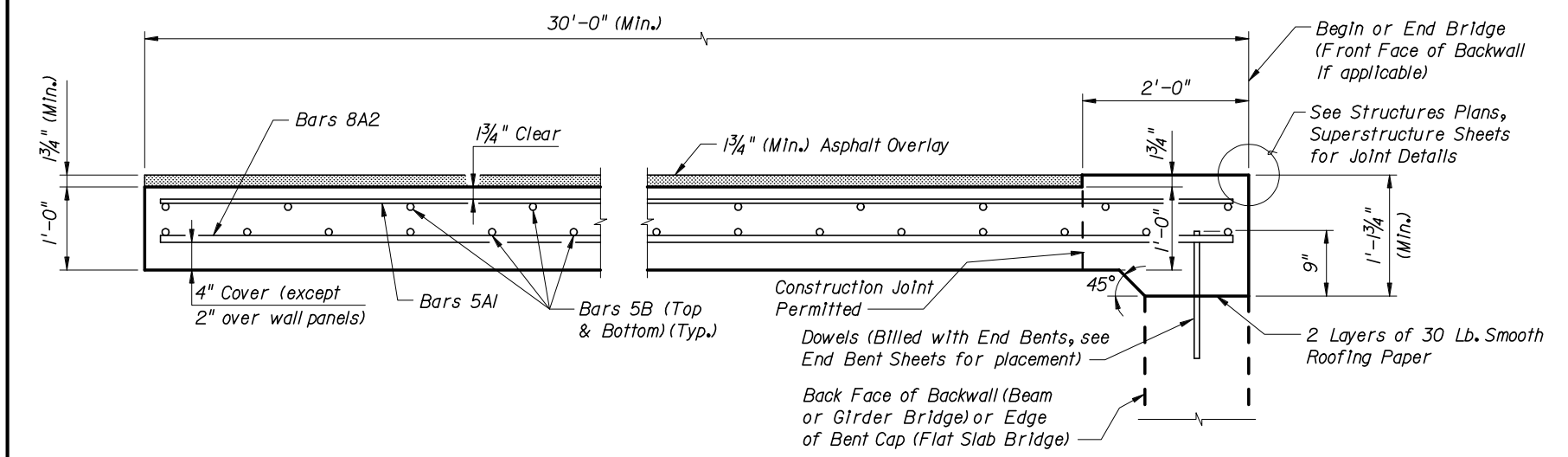

INSTRUCTIONS TO DESIGNER:
 These Indexes shall be supplemented in Structures Plans with additional sheets showing as a minimum a Plan View with geometry and pertinent information not covered by these Indexes e.g. Survey Lines, PGL, Direction of Stationing, Phase Construction Joints, Raised Sidewalks and any other information necessary to accurately complete detailing of the Approach Slabs. Approach Slab Finish Grade Elevations shall be included with the Bridge Finish Grade Elevations in the Structures Plans.
 All Reinforcing bars are to be shown in the Reinforcing Steel List as straight bars (Types 1 and 2). Bars 5C are 5'-0" long.

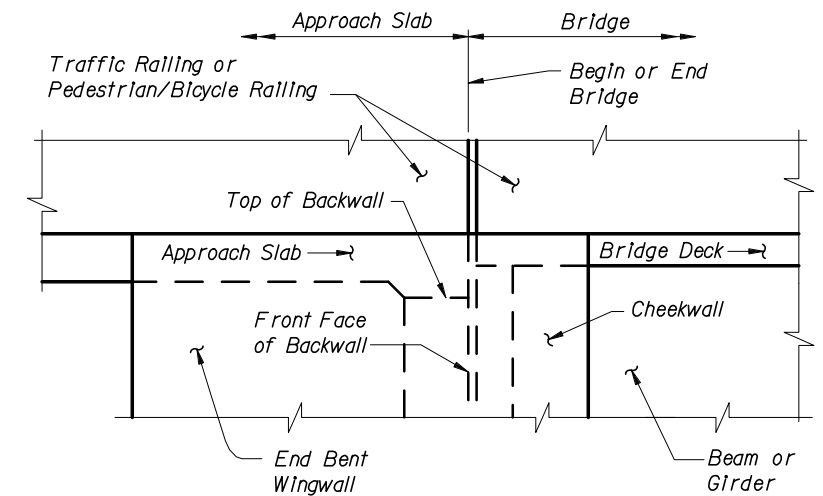
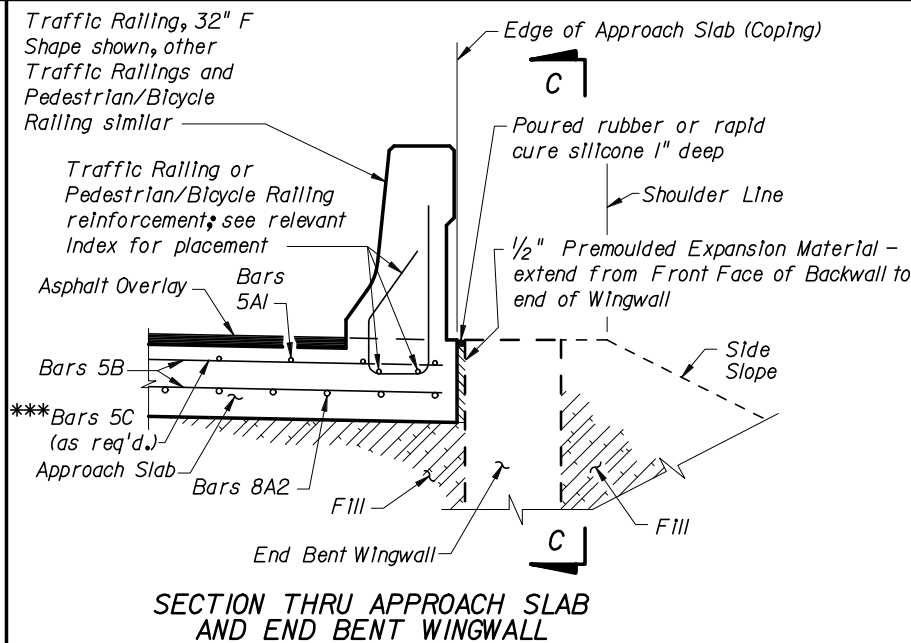
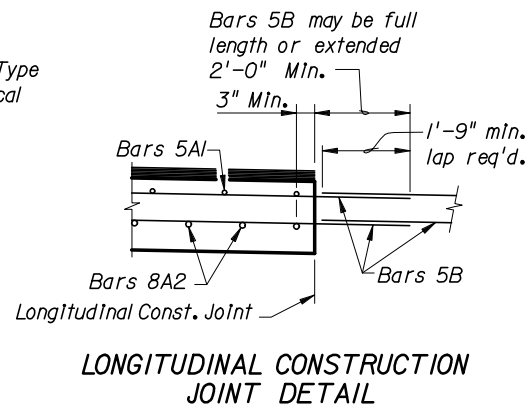
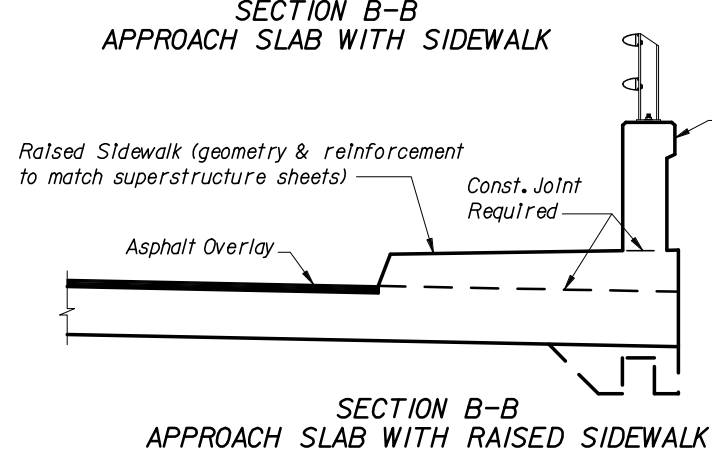
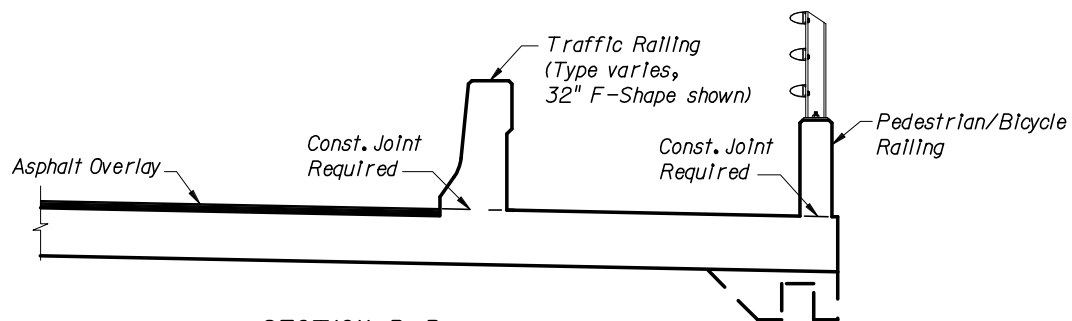
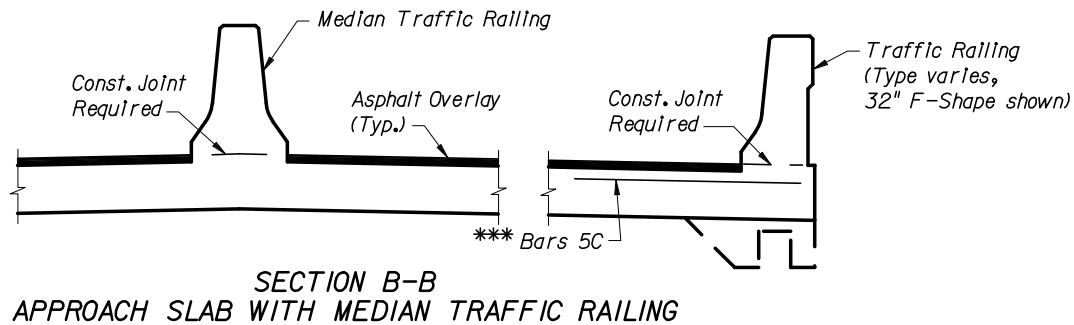
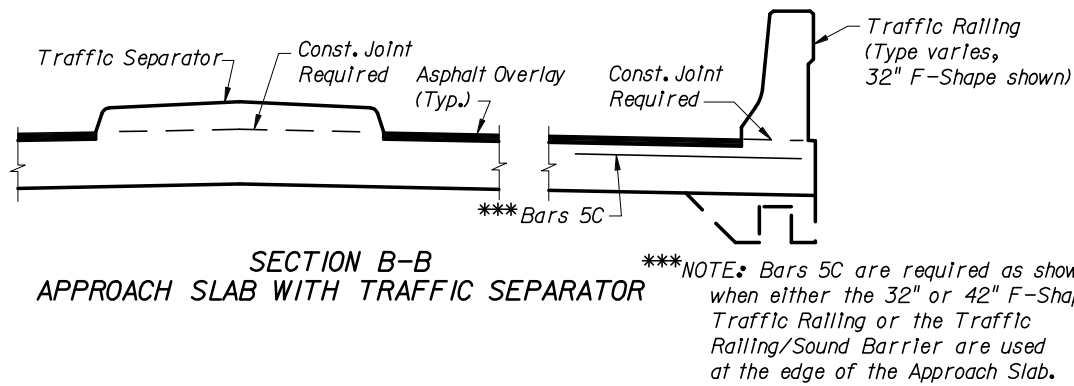
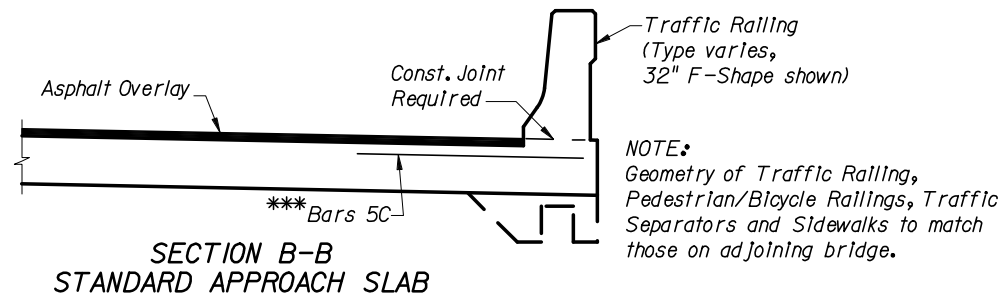

APPROACH SLAB WITH WINGWALL DETAILS

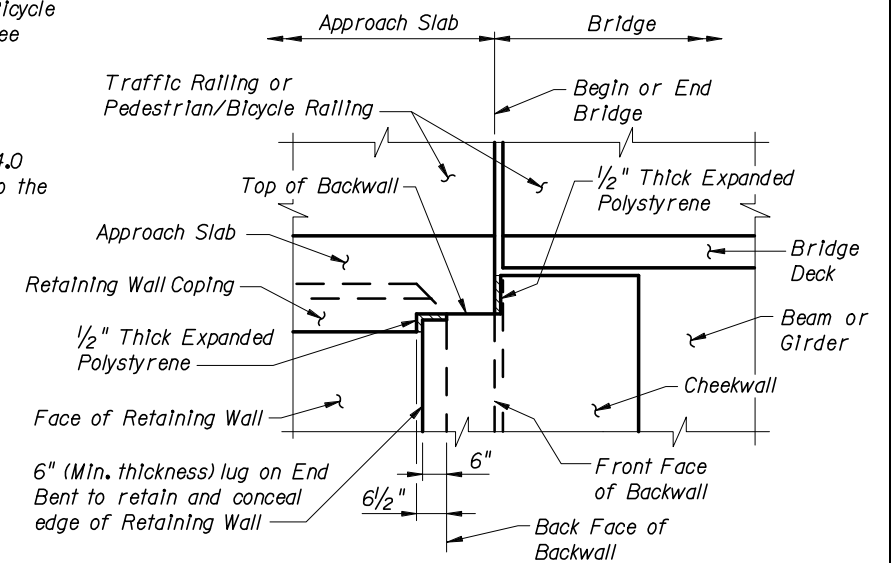
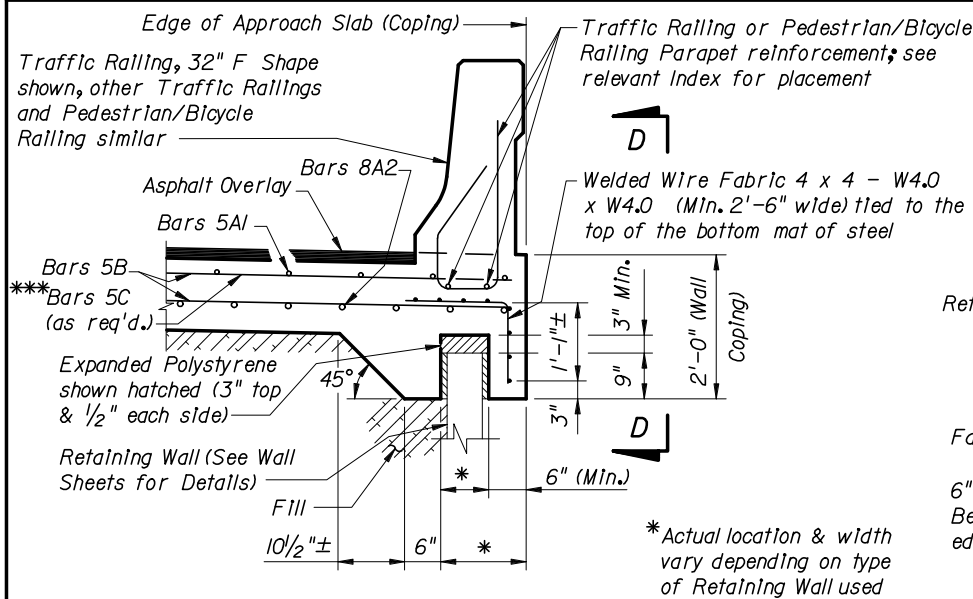

APPROACH SLAB WITH RETAINING WALL DETAILS

CROSS REFERENCES:

For location of Section B-B and Longitudinal Construction Joint Detail see Index No. 20900, Sheet 1 of 2.

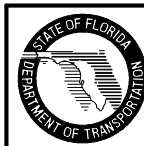

2006 FDOT Design Standards

**APPROACH SLABS
(FLEXIBLE PAVEMENT APPROACHES)**

Last Revision	Sheet No.
07/01/05	2 of 2
Index No.	
20900	