

END VIEW AT END DIAPHRAGM

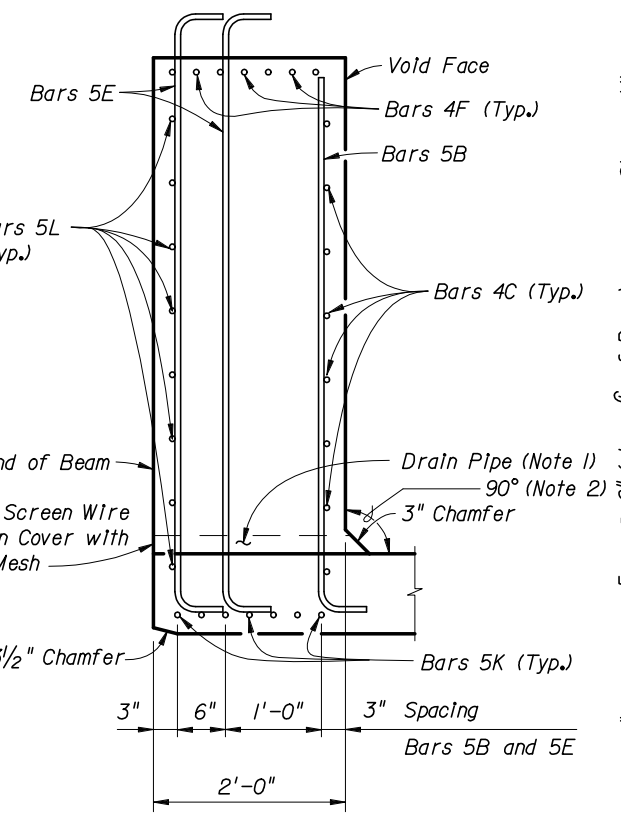

SECTION C-C

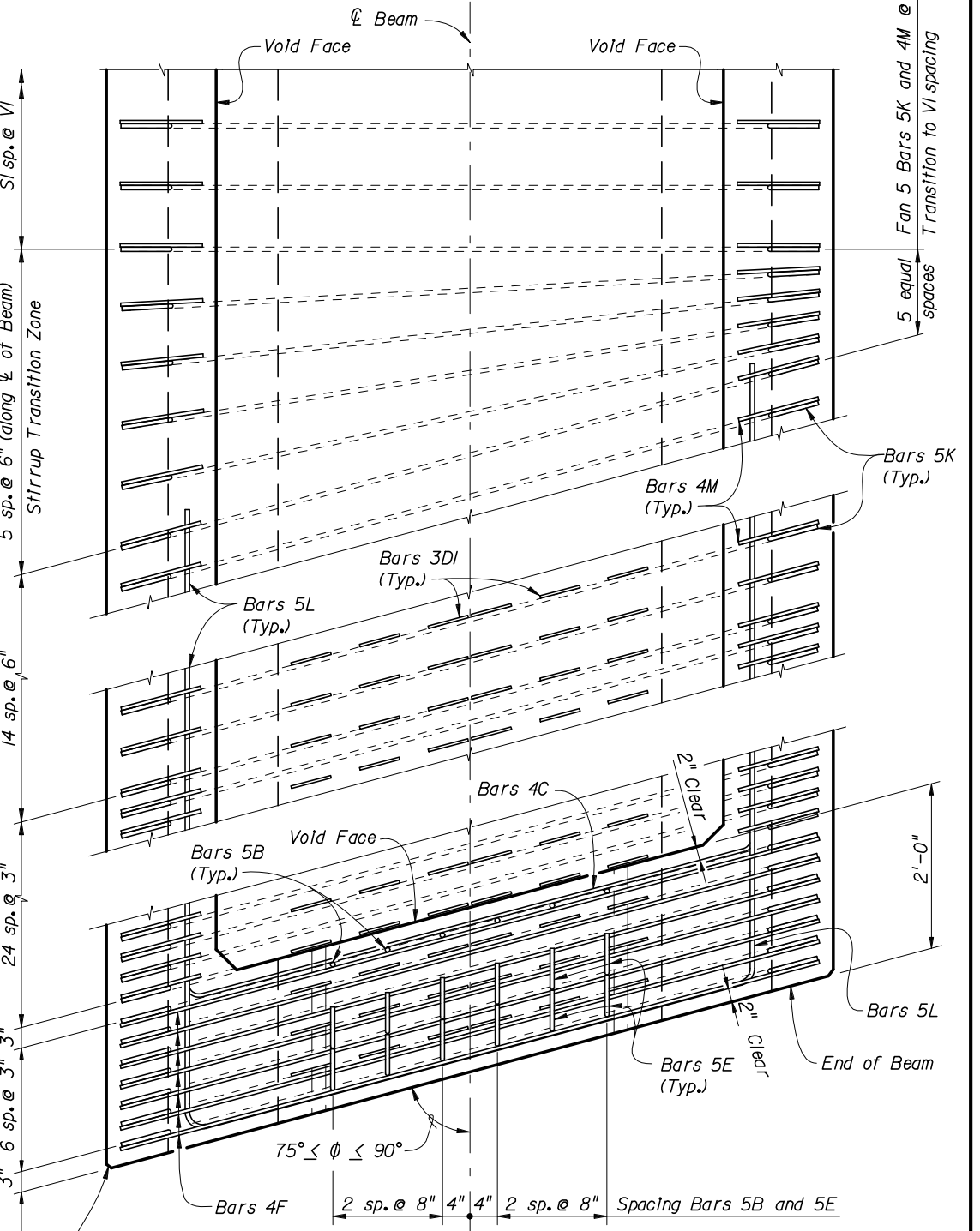

TOP VIEW OF SKEWED END DIAPHRAGM AND STIRRUP TRANSITION ZONE (Bars 3D2 Not Shown For Clarity)

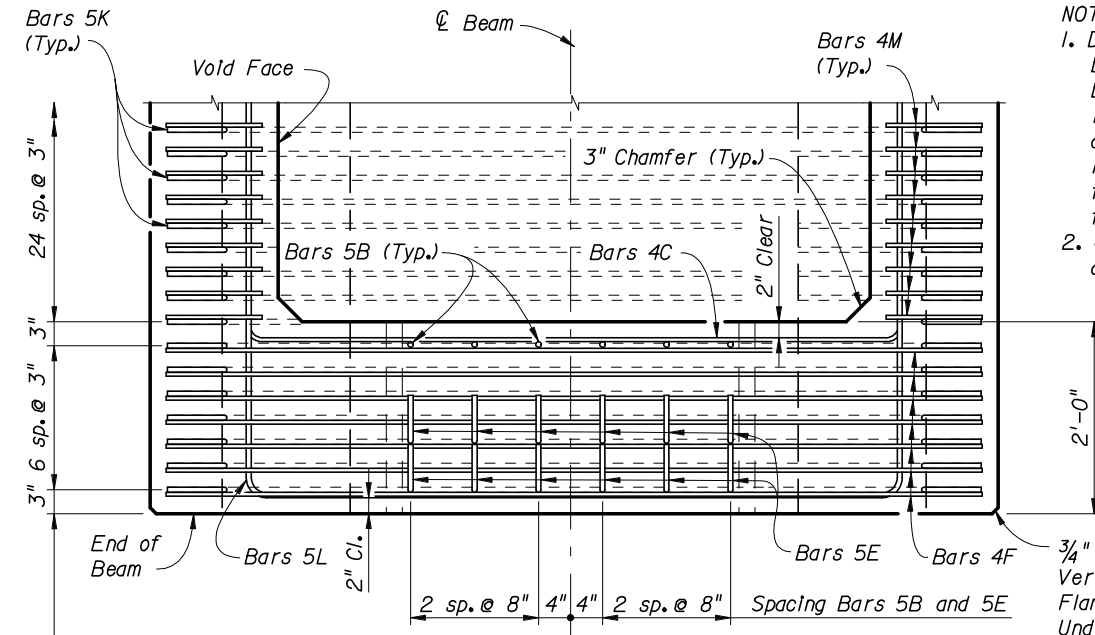

TOP VIEW OF END DIAPHRAGM (Bars 3D1 And 3D2 Not Shown For Clarity)

- NOTES:
1. Drains shall be placed adjacent to each web at each beam end (four drains per beam). Drain Pipe shall be 2" Nominal Pipe Size, Schedule 80 PVC. Provide removable pipe plugs to prevent concrete entrance during beam casting. Plugs to be removed from the inside after casting. Galvanized screen wire shall cover the end of the pipe and bent down around the sides of the pipe, a minimum of 1" and secured prior to casting.
  2. Concrete face may be sloped with a maximum 1:24 draft to facilitate formwork removal.

Spacing Bars 5K (Along centerline of Beam) (Bars 4F and 4M are Paired with Bars 5K as shown)

3/4" Chamfer along the Vertical Face of the Top Flange and Web and Underside of the Top Flange (Typ.)

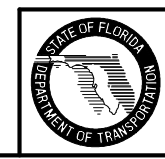

2006 FDOT Design Standards

FLORIDA U 72 BEAM - STANDARD DETAILS

Last Revision	Sheet No.
07/01/05	2 of 3
Index No.	
20272	

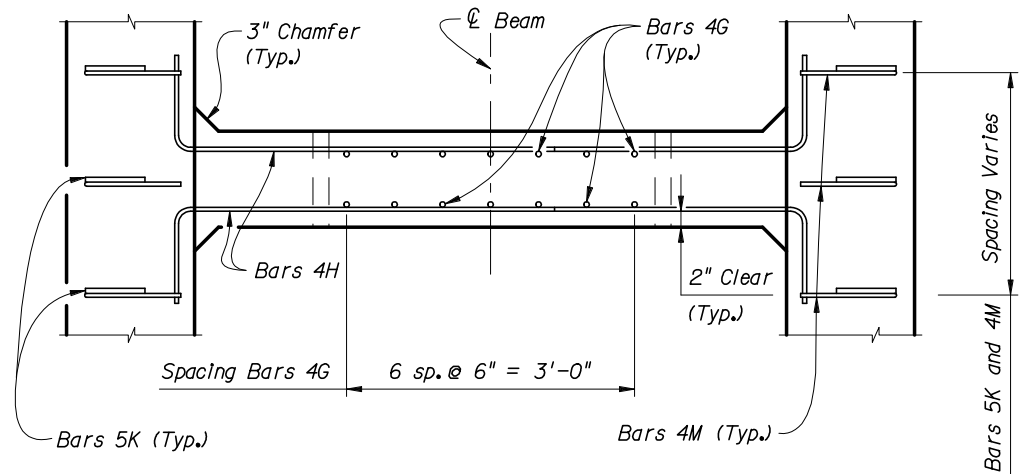

TOP VIEW OF INTERMEDIATE DIAPHRAGM

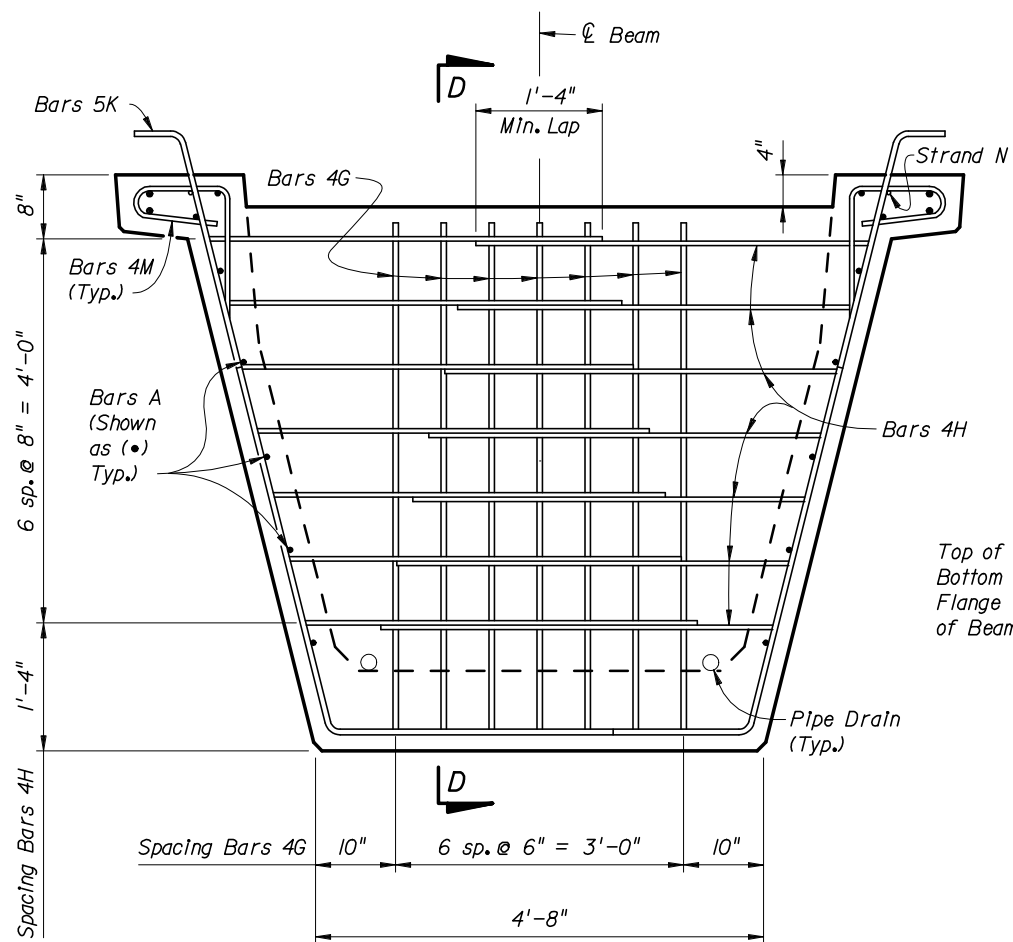

SECTION AT INTERMEDIATE DIAPHRAGM

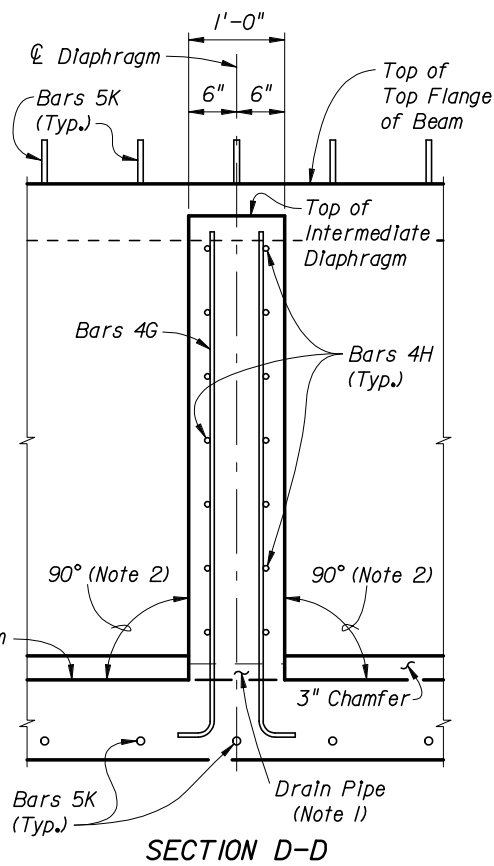

SECTION D-D

NOTES:

1. Drains shall be placed adjacent to each web at each intermediate diaphragm (two drains per intermediate diaphragm). Drain Pipe shall be 2" Nominal Pipe Size, Schedule 80 PVC. Provide removable pipe plugs to prevent concrete entrance during beam casting. Plugs to be removed from the inside after casting.
2. Concrete face may be sloped with a maximum 1:24 draft to facilitate formwork removal.
3. Intermediate diaphragms must be cast and concrete release strength obtained prior to removing beam from casting bed.

CONVENTIONAL REINFORCING STEEL BENDING DIAGRAMS

BILL OF REINFORCING STEEL FOR ONE BEAM ONLY

MARK	SIZE	NO. REQ'D	LENGTH
A1	6	4	DIM L - 4"
A2	4	14	DIM L - 4"
B	5	12	6'-1"
C	4	28	5'-7"
D1	3	228	1'-6"
D2	3	38	4'-6"
E	5	24	7'-3"
F	4	28	6'-9"
G	4	See Table	6'-0"
H	4	See Table	5'-1"
K	5	See Table	10'-0"
L	5	32	19'-6"
M	4	See Table	3'-11"
N	3/8" $\phi$ Strand	2	DIM L - 3"

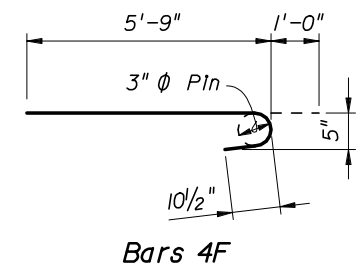
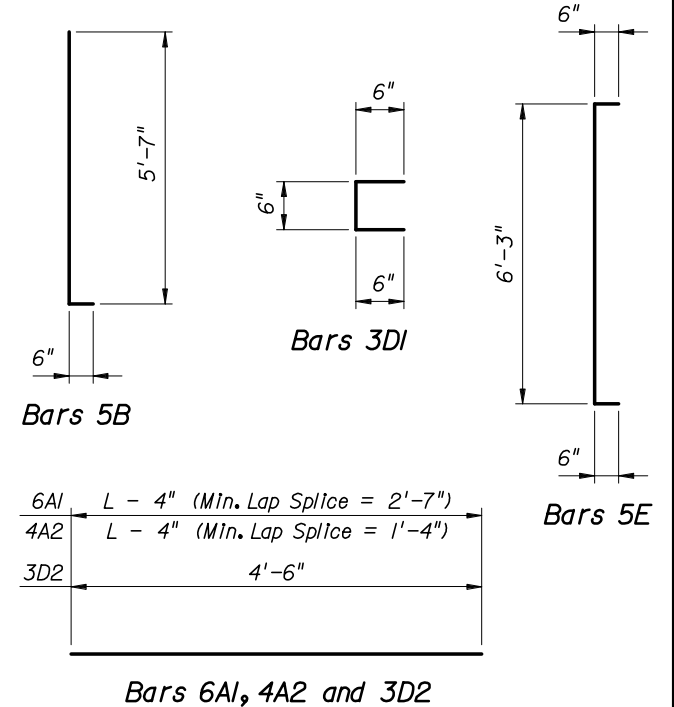

Bars 4F

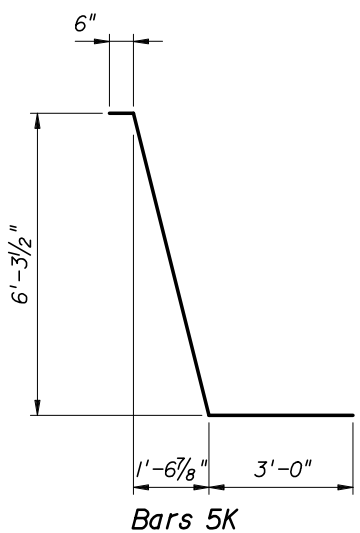

Bars 5K

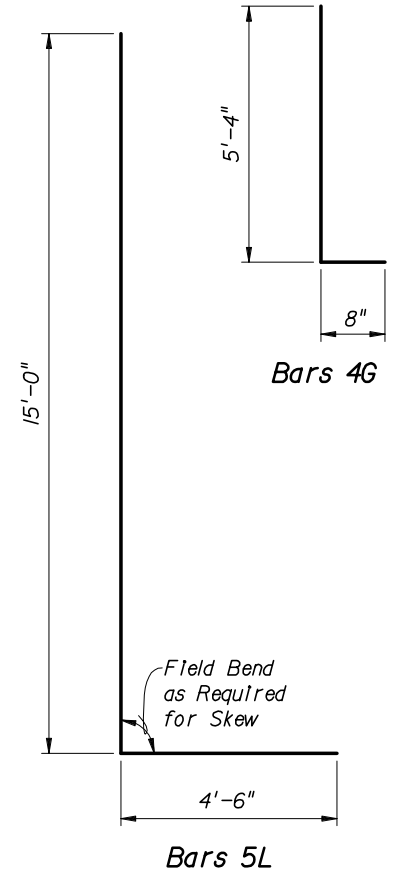

Bars 4G

Bars 5L

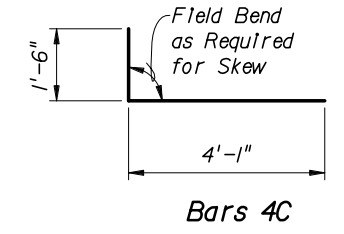

Bars 4C

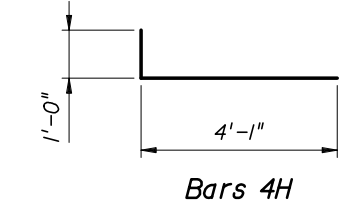

Bars 4H

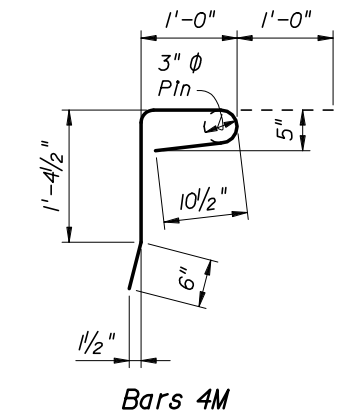

Bars 4M

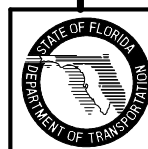

2006 FDOT Design Standards

FLORIDA U 72 BEAM - STANDARD DETAILS

Last Revision 07/01/05  
 Sheet No. 3 of 3  
 Index No. 20272