

* DIM.B Is 1'-6" for Florida U 48 and 54 Beams and 2'-0" for Florida U 63 and 72 Beams.

CONDITION 1
(P = 0.0)

** Concrete face may be sloped with a maximum 1:24 draft to facilitate formwork removal.

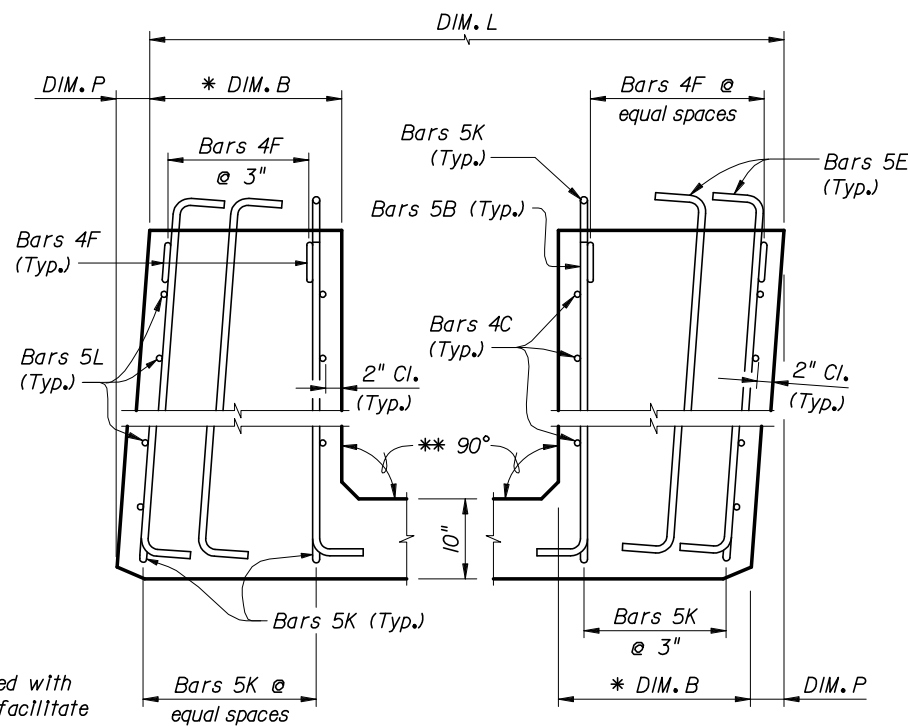

CONDITION 2

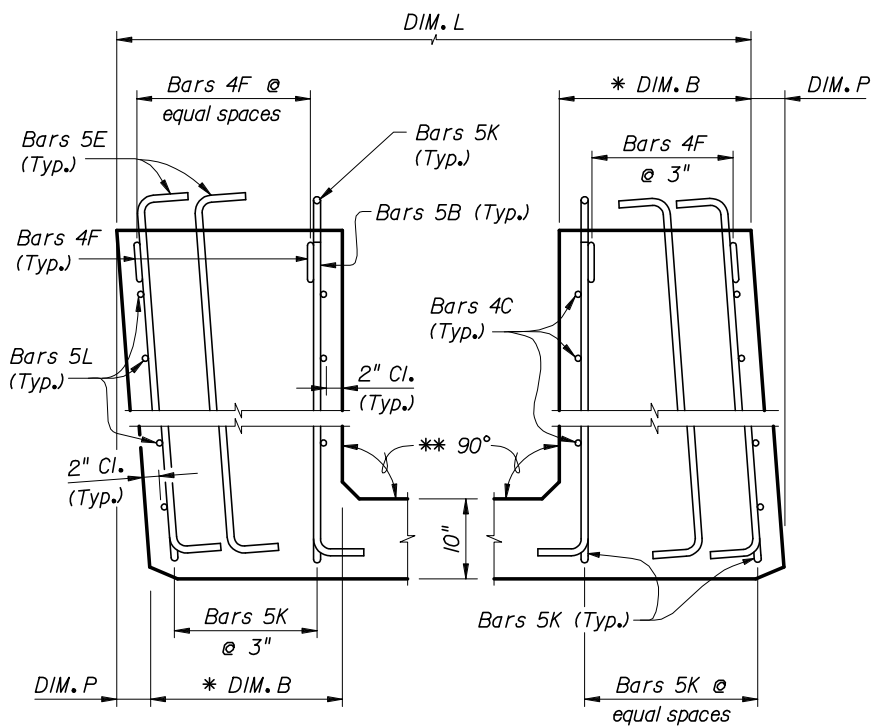

CONDITION 3

SCHMATIC END ELEVATIONS OF BEAMS
(Showing Vertical Bevel of Beam End)

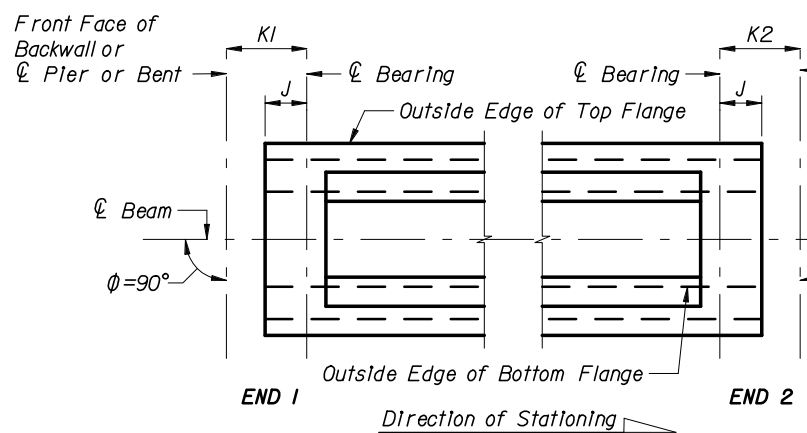

CASE 1

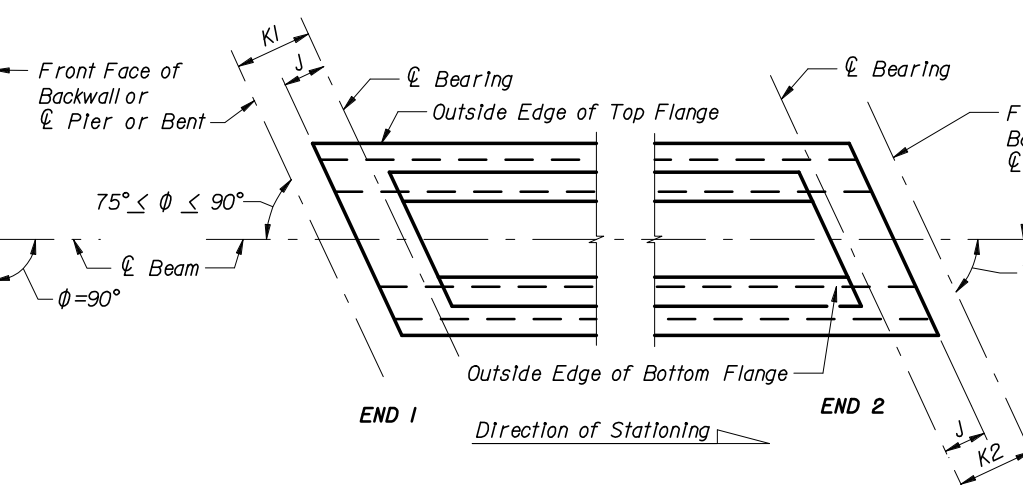

CASE 2

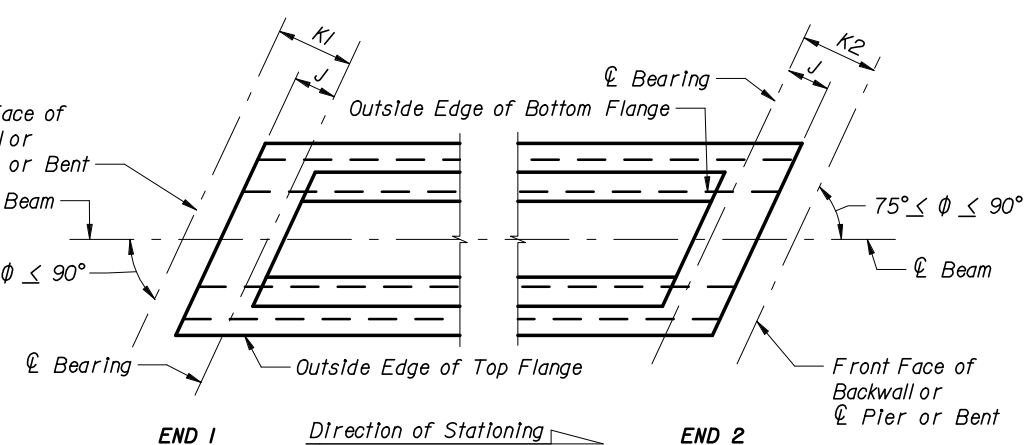

CASE 3

SCHMATIC PLAN VIEWS AT BEAM ENDS

NOTE:
Work this Index with Florida U Beam - Table of Beam Variables in Structures Plans.



2006 FDOT Design Standards

TYPICAL FLORIDA U BEAM DETAILS AND NOTES

Last Revision	Sheet No.
07/01/05	1 of 2
Index No.	
20210	

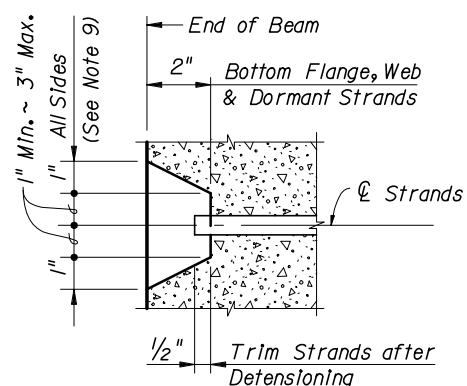

TYPICAL STRAND BLOCKOUT DETAIL

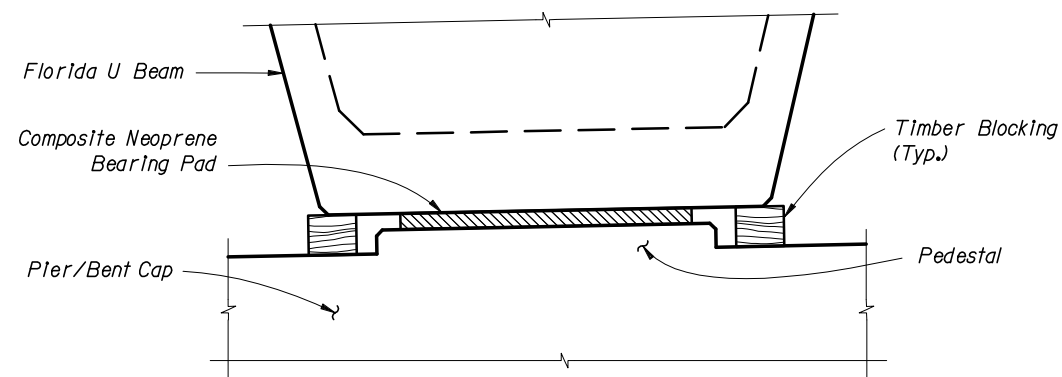

TEMPORARY BLOCKING OF BEAM ENDS

BEAM NOTES

1. All bar dimensions are out-to-out.
2. Strands N (Dormant Strands) shall be either ASTM A416, Grade 250 or Grade 270, seven-wire strands $\frac{3}{8}$ " Φ or larger, stressed to 10,000 lbs. each.
3. Unless otherwise noted in Structures Plans, the minimum concrete cover for reinforcing steel shall be 2".
4. At option of the Contractor and with the Engineer's Approval, deformed welded wire fabric may be used in lieu of Bars 5B, 4C, 3D, 5E, 4F, 4G, 4H, 5K, 5L and 4M except as noted below in note 7, provided the wire sizes and spacing match those shown on the Standard Beam Detail sheets for these bars. Welded wire fabric shall conform to ASTM A497.
5. Place $2\frac{1}{2}$ " NPS x 5" PVC Sch. 40 Safety Sleeve with cap in both top flanges spaced on 8'-0" (Max.) centers. Shift Bars 5K & 4M locally to allow placement. Holes shall be free of debris and water prior to casting deck.

6. For Beams with vertically beveled end conditions when "DIM.P" exceeds 1", Bars 5E and the first Bars 4F and 5K shall be placed parallel to the end of the beam. The remaining Bars 4F and 5K within the limits of "DIM.B" shall be fanned at equal spaces.
7. Welded deformed wire fabric shall not be used for the end reinforcement (Bars 5B, 4C, 3D, 5E, 4F, 5K, and 5L) for beams with skewed end conditions or vertically beveled end conditions when "DIM.P" exceeds 1".
8. Bars 5K shall be placed and tied to the fully bonded strands in the bottom row (see "STRAND PATTERN" in Structures Plans).
9. Strand Protection at beam ends shall consist of a 2" deep recess formed around all strands (including dormant) or strand groups. Extend recess to face of web and bottom of flange for bottom row of strands. After detensioning, cut strands $\frac{1}{2}$ " from recessed surface and fill recess with a Type F-2 Epoxy Compound in accordance with Section 926 of the Specifications.
10. The Contractor shall use Size No. 67 maximum sized aggregate.
11. Stay-in-Place metal deck forms shall be used inside the beams.

12. The Contractor shall evaluate the need for temporary bracing between U Beams, based on the selected deck forming system and concrete placement sequence. In addition, timber blocking shall be placed beneath the exterior face of the webs at the both ends of all beams, prior to deck casting. Blocking shall be left in place for at least 4 days after deck casting and afterwards removed at the Contractor's convenience.
13. For referenced Dimensions, Angles and Case Numbers see Table of Beam Variables in Structures Plans.

INSTRUCTIONS TO DESIGNER:

To limit Bursting Forces, the maximum prestress force at beam ends from fully bonded strands must be limited to the following:

Beam Type	Max. Bonded Prestress Force	Index No.	Issue Date
Florida U48 & U54	2790 Kips	20248 & 20254	7-01-05
Florida U63 & U72	3070 Kips	20263 & 20272	7-01-05

No losses shall be applied when calculating the Bonded Prestress Force. The reinforcing in the ends of the beams must not be modified without the approval of the State Structures Design Engineer.

NOTE:
Work this Index with Florida U Beam - Table of Beam Variables in Structures Plans.



2006 FDOT Design Standards

TYPICAL FLORIDA U BEAM DETAILS AND NOTES

Last Revision	Sheet No.
07/01/05	2 of 2
Index No.	
20210	