

BILL OF REINFORCING STEEL FOR ONE BEAM ONLY

MARK	NOTE NUMBERS	SIZE	NUMBER REQUIRED	LENGTH (NOTE 1)
A	—	5	8	2'-0"
D1	9, 11 & 14	3	20	See Table
D2	9, 11 & 14	3	20	See Table
K	2, 9, 11 & 13	5	See Table	7'-0"
L	3 & 4	4	24	6'-3"
M1	9 & 10	4	14	See Table
M2	9 & 10	4	14	See Table
M3	9	4	See Table	3'-2"
N	5	$\frac{3}{8}$ " ϕ Strand	4	DIM L + 5"
Y	9 & 11	5	12	4'-8"
Z	2, 9, 11 & 13	5	12	6'-7"

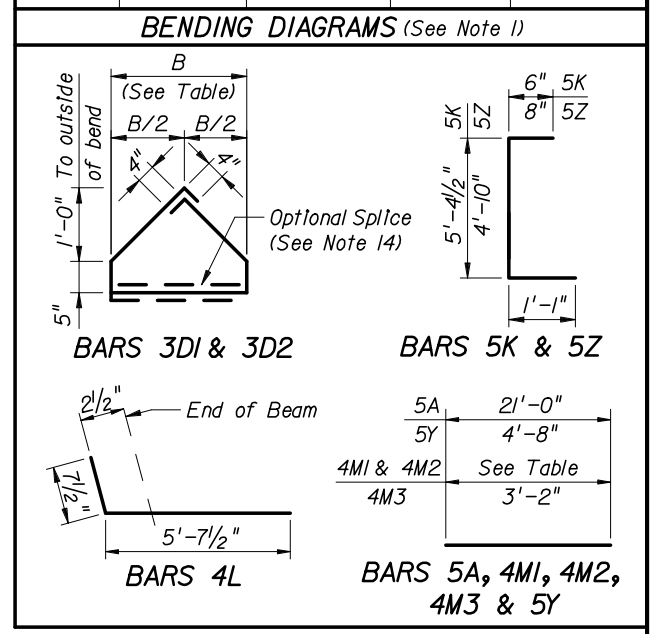

NOTES:
 Work this Index with Index No. 20110 - Typical AASHTO and Bulb-T Beam Details and Notes and the AASHTO Type V Beam - Table of Beam Variables in Structures Plans.
 For referenced notes, see Index No. 20110.
 For Dimensions L, R, VI thru V4 and number of spaces S1 thru S4, see AASHTO Type V Beam - Table of Beam Variables.

