

**SIGNAL PLACEMENT AT RAILROAD CROSSING  
(2 - LANE DESIGN)**

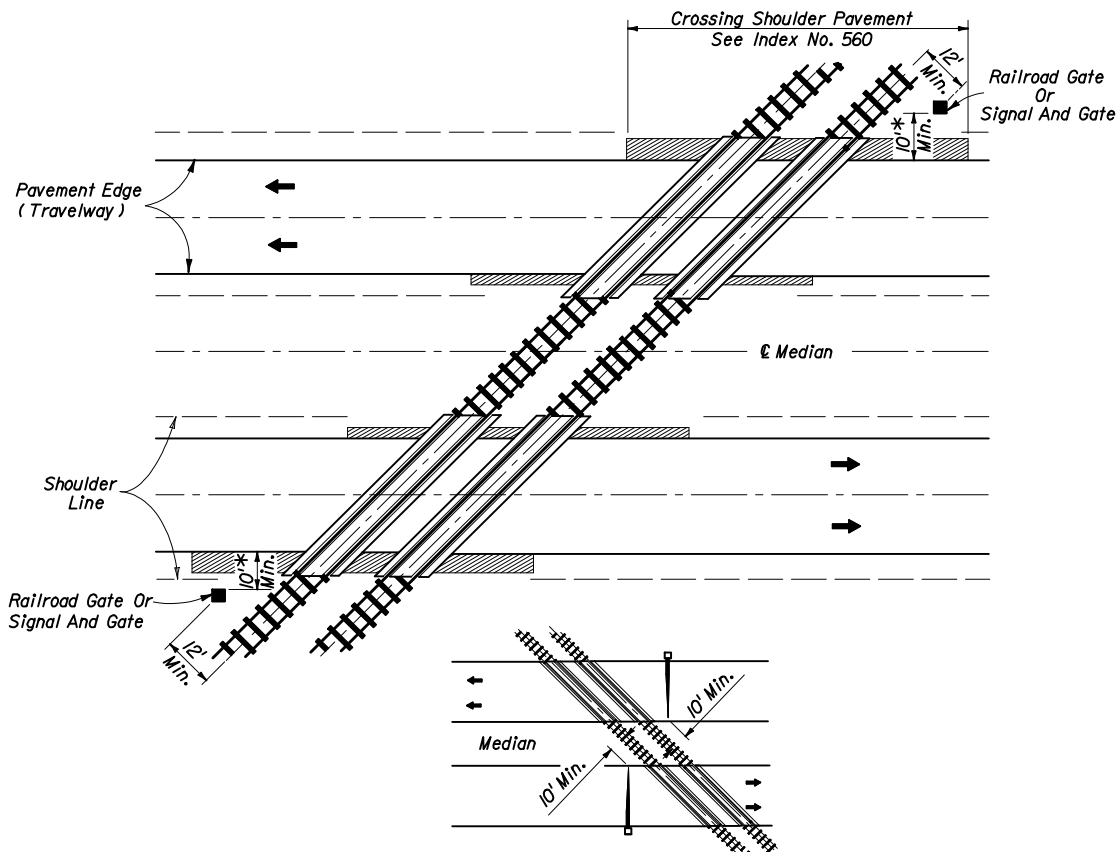

**SIGNAL PLACEMENT AT RAILROAD CROSSING  
(4 - LANE DESIGN)**

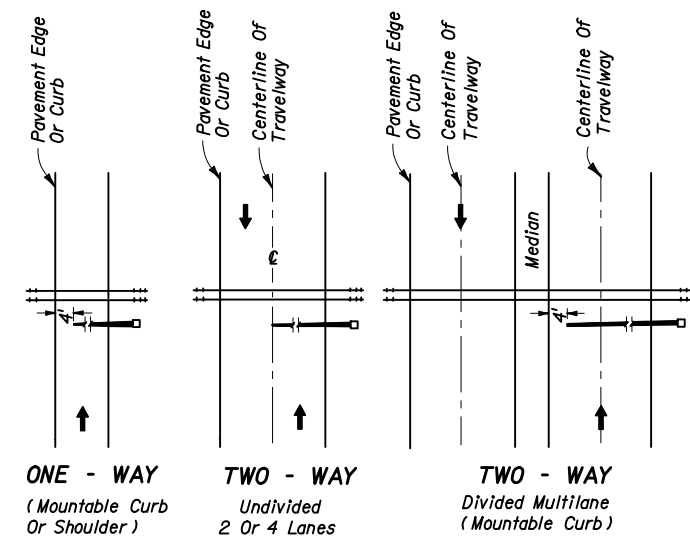

Note :  
Arrows denote direction of travel not lane indication

**FIGURE 1**  
**Gate Length Requirements**  
See Note 5 Sheet 3

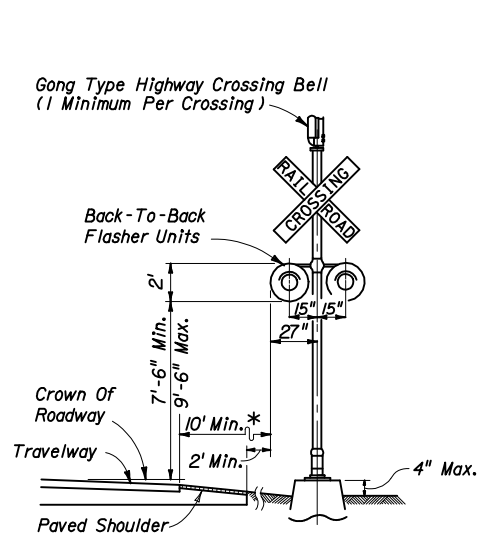

**TYPE I**

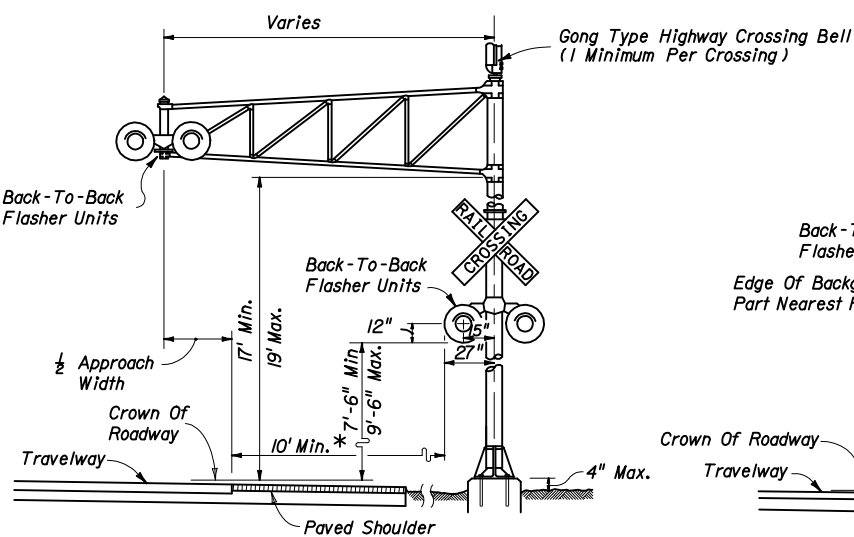

**TYPE II**

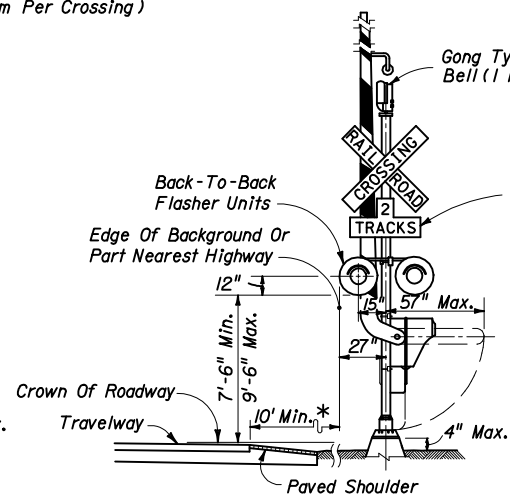

**TYPE III**

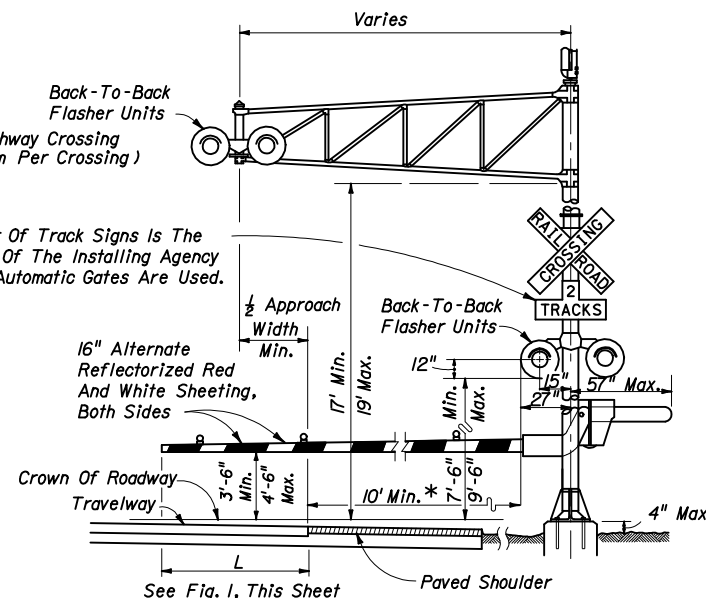

**TYPE IV**

\* When 10' is deemed impracticable the control device can be located as close as 2' from the edge of a paved shoulder but not less than 6' from the edge of the near traffic lane.

Note :  
Two separate foundations may be required (one for signals, one for gate), depending on type of equipment used.

**General Notes**

- No guardrail is proposed for signals; however, some form of impact attenuation device may be specified for certain locations.
- Advance flasher to be installed when and if called for in plans or specifications.
- Top of foundation shall be no higher than 4" above finished shoulder grade.
- Type of traffic control device
  - Flashing signals
  - Flashing signals with cantilever
  - Flashing signals with gate
  - Flashing signals with cantilever & gate
  - Gate
- Class of traffic control devices
  - Flashing signals - one track
  - Flashing signals - multiple tracks
  - Flashing signals and gates - one track
  - Flashing signals and gates - multiple tracks

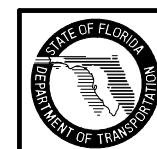

2006 FDOT Design Standards

**RAILROAD GRADE CROSSING  
TRAFFIC CONTROL DEVICES**

Last Revision	Sheet No.
07/01/05	1 of 4
Index No.	
17882	

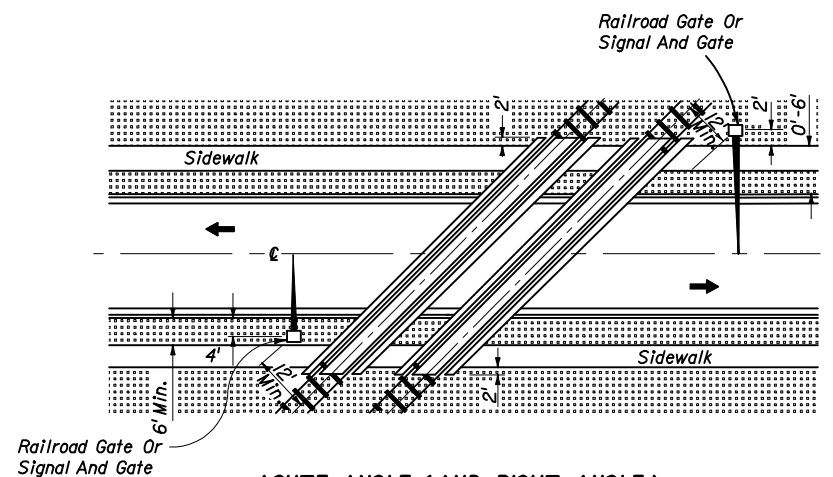

**ACUTE ANGLE (AND RIGHT ANGLE)**  
**SIGNAL PLACEMENT AT RAILROAD CROSSING**  
**(2 LANES, CURB & GUTTER)**

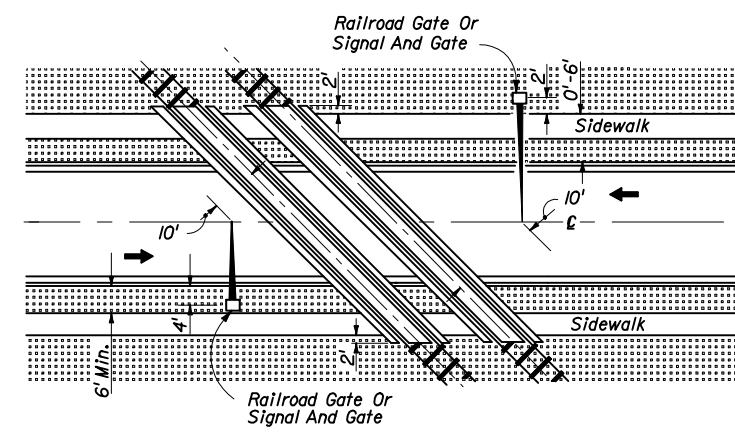

**OBTUSE ANGLE**  
**SIGNAL PLACEMENT AT RAILROAD CROSSING**  
**(2 LANES, CURB & GUTTER)**

**GENERAL NOTES**

1. The location of flashing signals and stop lines shall be established based on future (or present) installation of gate with appropriate track clearances.
2. Where plans call for railroad traffic control devices to be installed in curbed medians, the minimum median width shall be 12'-6".
3. Location of railroad traffic control device is based on the distance available between face of curb & sidewalk.  
 0' to 6' - Locate device outside sidewalk.  
 Over 6' - Locate device between face of curb and sidewalk.
4. Stop line to be perpendicular to edge of roadway, approx. 15' from nearest rail; or 8' from and parallel to gate when present.

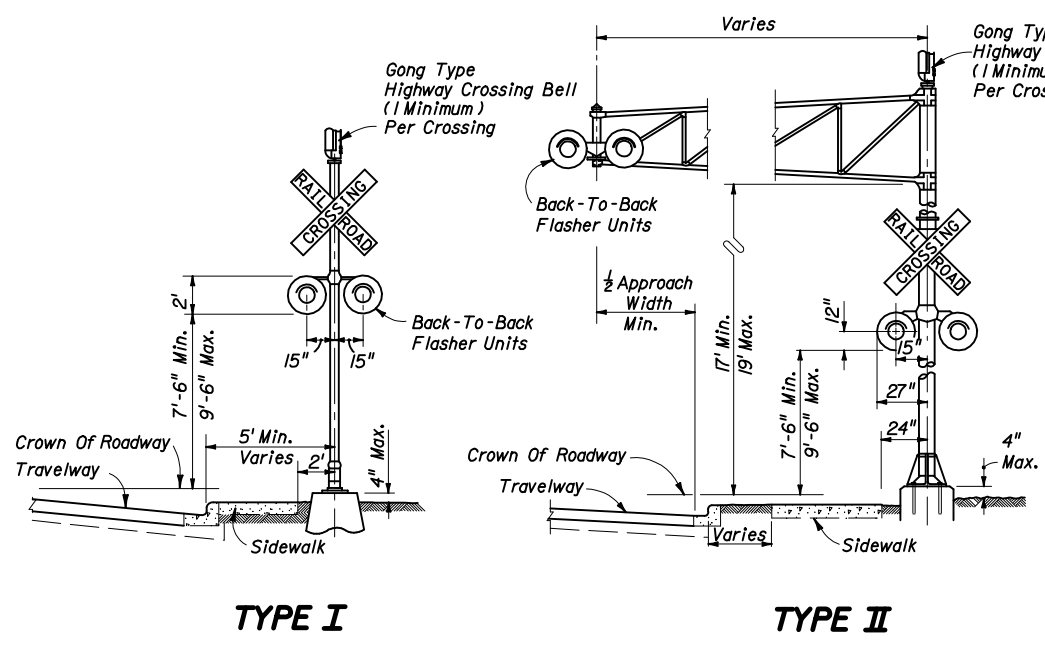

**TYPE I**

**TYPE II**

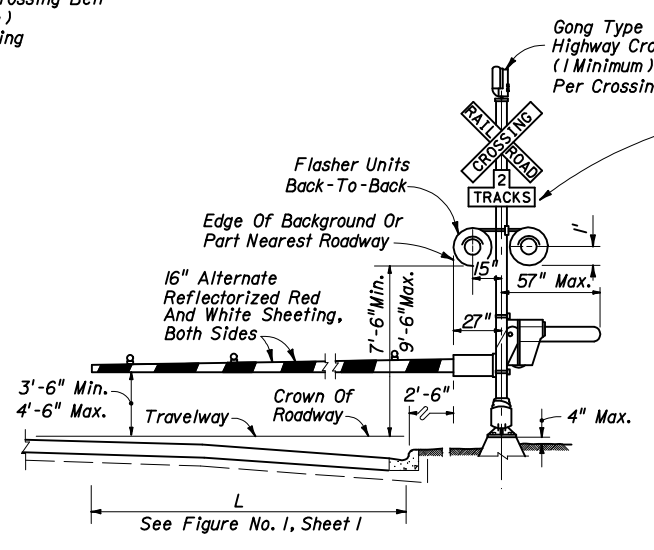

**TYPE III**

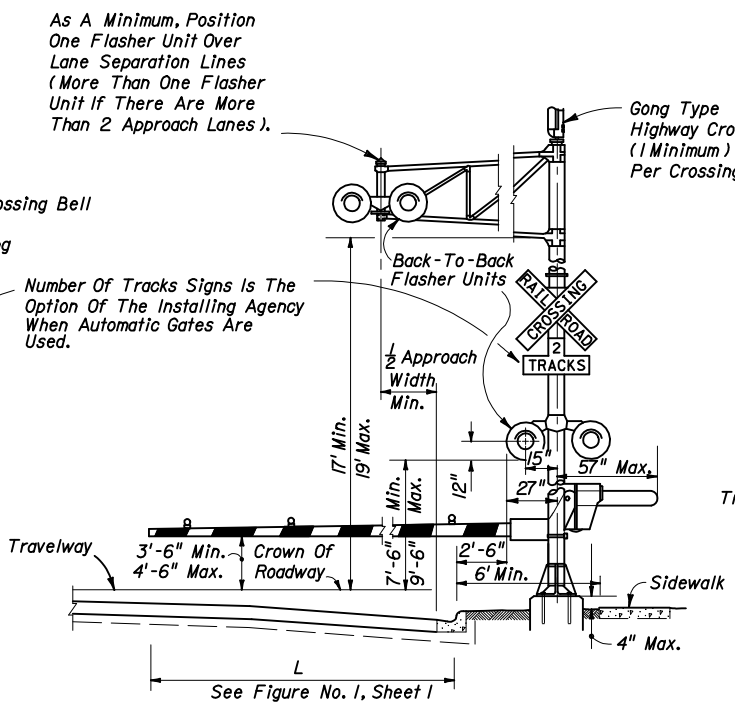

**TYPE IV**

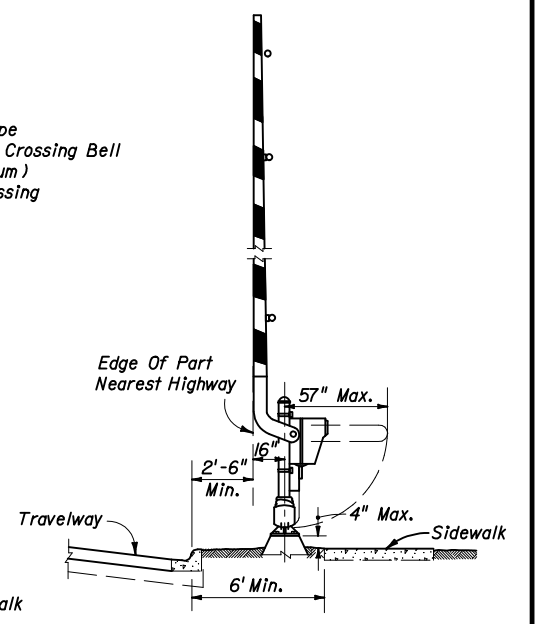

**TYPE V**



2006 FDOT Design Standards

**RAILROAD GRADE CROSSING**  
**TRAFFIC CONTROL DEVICES**

Last Revision 00  
 Sheet No. 2 of 4

Index No.  
**17882**

**RAILROAD CROSSING AT TWO (2)-LANE ROADWAY**

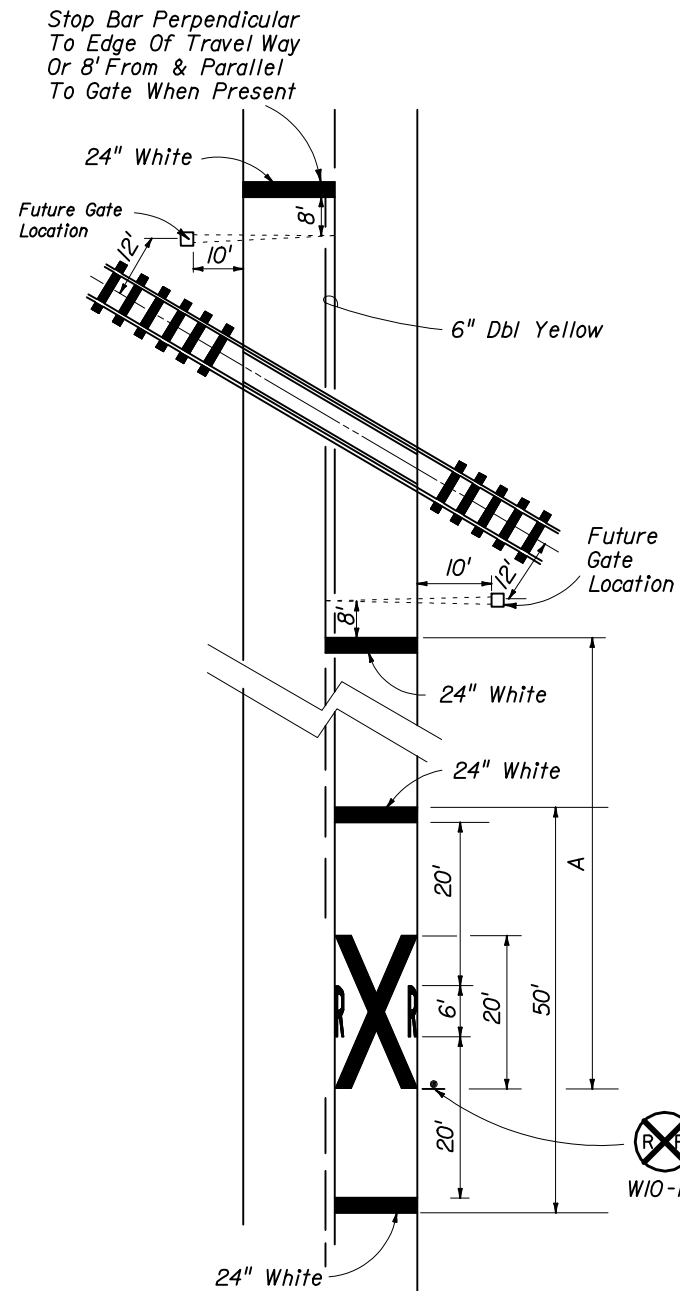

**RAILROAD CROSSING AT MULTI-LANE ROADWAY**

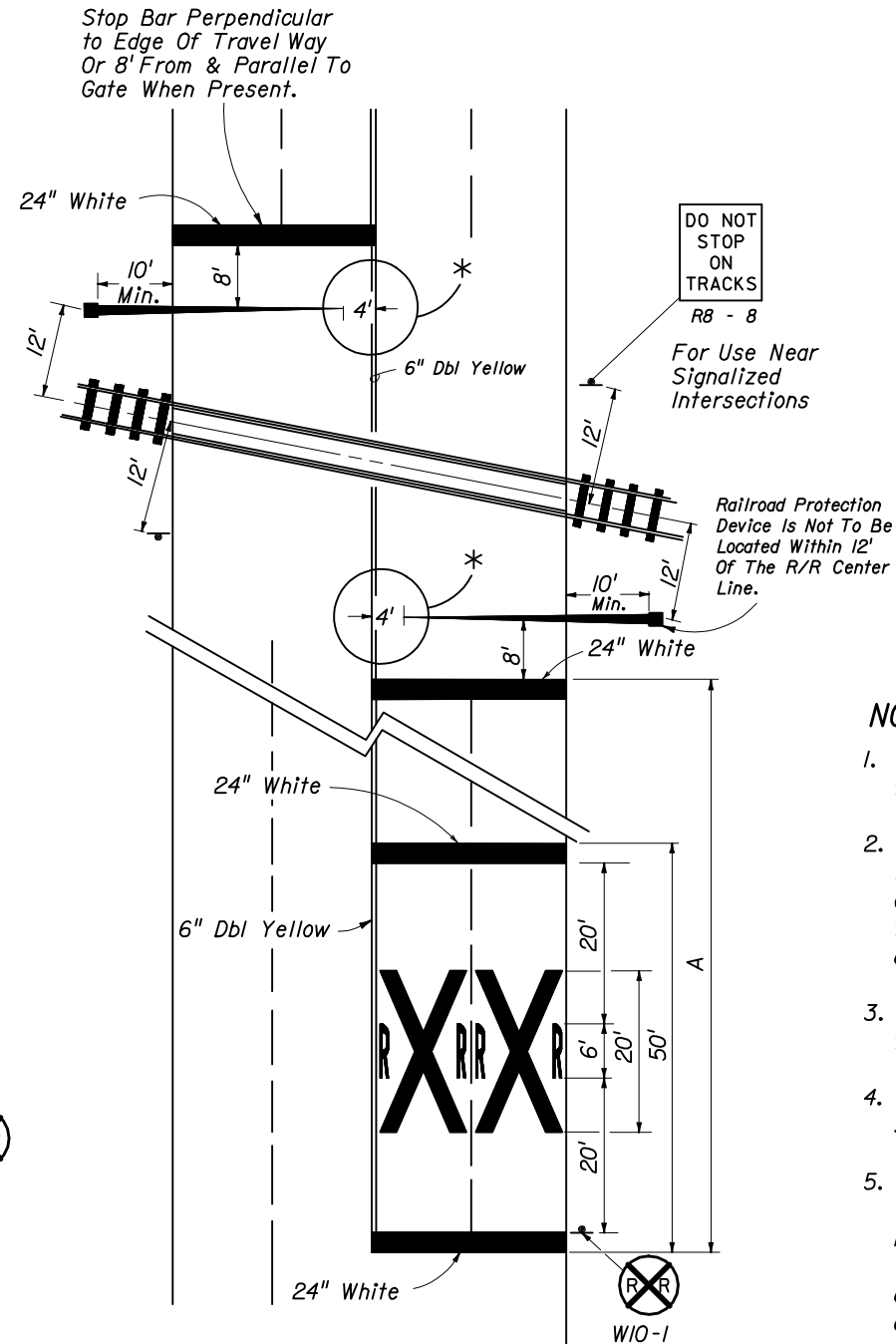

**RELATIVE LOCATION OF CROSSING TRAFFIC CONTROL DEVICES**

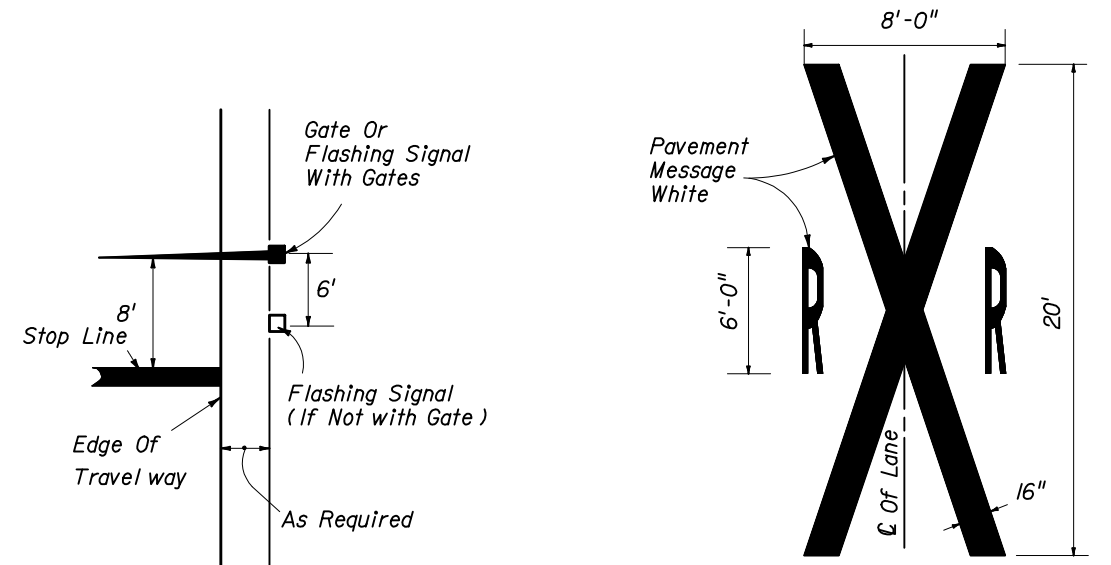

**NOTES:**

1. When computing pavement message, quantities do not include traverse lines.
2. Placement of sign W10-1 in a residential or business district, where low speeds are prevalent, the W10-1 sign may be placed a minimum distance of 100' from the crossing. Where street intersections occur between the R/R pavement message and the tracks an additional W10-1 sign and additional pavement message should be used.
3. A portion of the pavement markings symbol should be directly opposite the W10-1 sign.
4. Recommended location for FTP-61-04 or FTP-62-04 signs, 100' urban and 300' rural. See index I7355 for sign details.
5. Gate Length Requirements:

*For two-way undivided sections:*

The gate should extend to within 1' of the center line. On multiple approaches the maximum gate length may not reach to within 1' of the center line. For those cases, the distance from the gate to the center line shall be a maximum of 4'.

*For one-way or divided sections:*

the gate shall be of sufficient length such that the distance from the gate tip to the inside edge of pavement is a maximum of 4'.

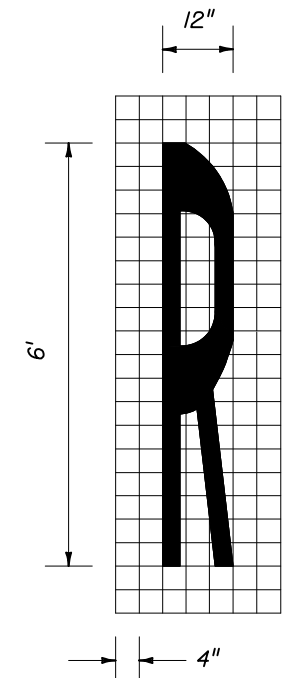

SPEED MPH	" A " IN FT
60	400
55	325
50	290
45	175
40	125
35	100
30	75
URBAN	50 MIN.



2006 FDOT Design Standards

**RAILROAD GRADE CROSSING TRAFFIC CONTROL DEVICES**

Last Revision 07/01/05  
Sheet No. 3 of 4  
Index No. 17882

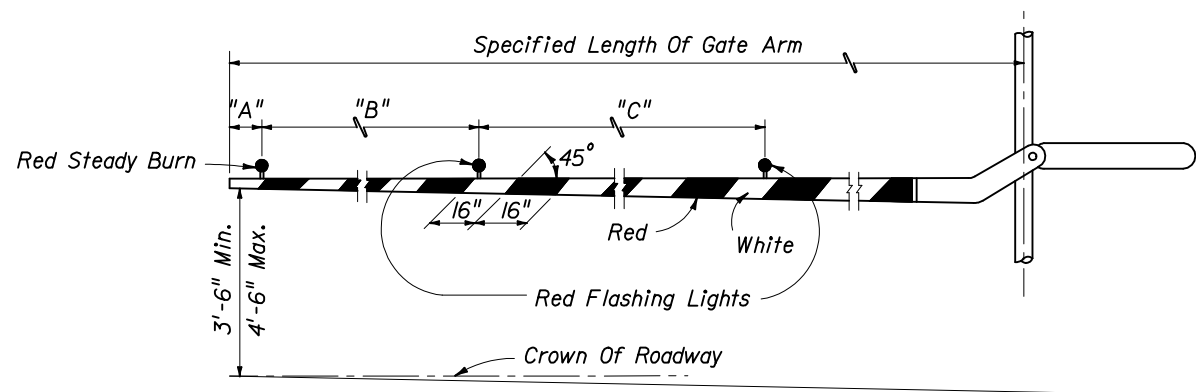

RAILROAD GATE ARM LIGHT SPACING

Specified Length Of Gate Arm	Dimension "A"	Dimension "B"	Dimension "C"
14 Ft.	6"	36"	5'
15 Ft.	18"	36"	5'
16-17 Ft.	24"	36"	5'
18-19 Ft.	28"	41"	5'
20-23 Ft.	28"	4'	5'
24-28 Ft.	28"	5'	5'
29-31 Ft.	36"	6'	6'
32-34 Ft.	36"	7'	7'
35-37 Ft.	36"	9'	9'
38 And Over	36"	10'	10'

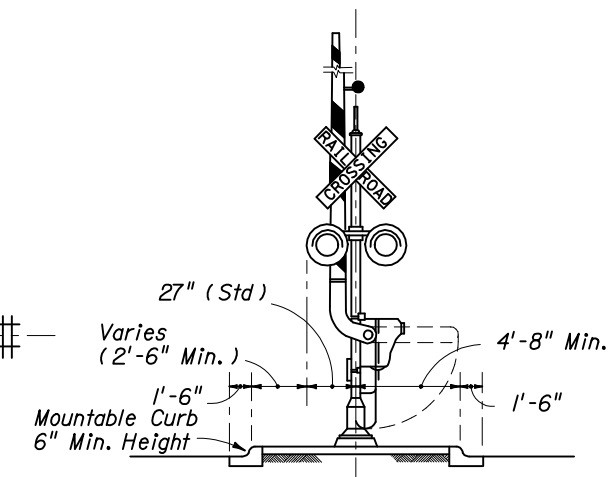
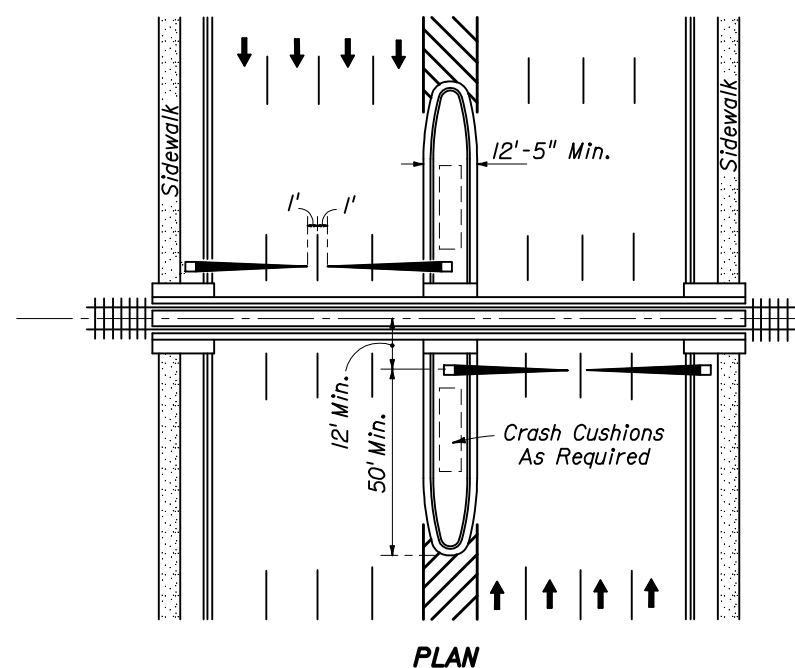

MEDIAN SECTION AT SIGNAL GATES

NOTE:  
For additional information see the "Manual On Uniform Traffic Control Devices", Part VIII; The "Traffic Control Handbook", Part VIII; and AASHTO "A Policy On Geometric Design Of Streets And Highways".

MEDIAN SIGNAL GATES FOR MULTI LANE UNDIVIDED URBAN SECTIONS

(THREE OR MORE DRIVING LANES IN ONE DIRECTION, 45 mph OR LESS)



2006 FDOT Design Standards

RAILROAD GRADE CROSSING TRAFFIC CONTROL DEVICES

Last Revision 00

Sheet No. 4 of 4

Index No. 17882