

CASE I Type I Object Markers shall consist of nine yellow reflectors mounted on a yellow reflective background or consist of a reflective panel of the same size with Type III-A, III-B or III-C yellow sheeting.

CASE II End of Road Markers shall consist of nine red reflectors mounted on a red reflective background or consist of a reflective panel of the same size with Type III-A, III-B or III-C red sheeting.

NOTES:

1. This index applicable to residential and minor streets only. Major streets to be evaluated on a case by case basis.
2. "T"-intersection-Two-Way arrows and reflectors are optional. The need should be based on a review of each location.
3. For additional details on aluminum round post, steel flanged channel post, sign panel material and bolts, nuts and washers see Index Nos. 11860 and 11865.
4. Case I Installation - The arrow panels and object markers shall be located approximately 20', but not less than 12' from the edge of the travel lane.
5. Dead end sign shall be posted a sufficient advance distance to permit the vehicle operator to avoid the dead end by turning off, if possible, at the nearest intersecting street.
6. For pavement marking see index no. 17346
7. No guardrail is required unless special field conditions require its use.

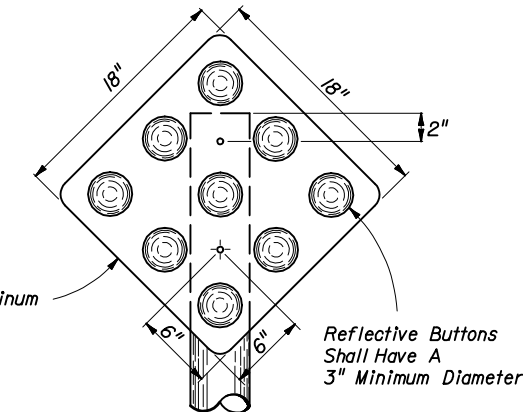
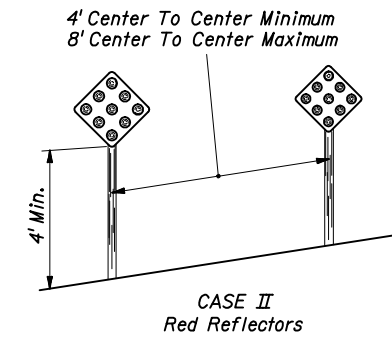
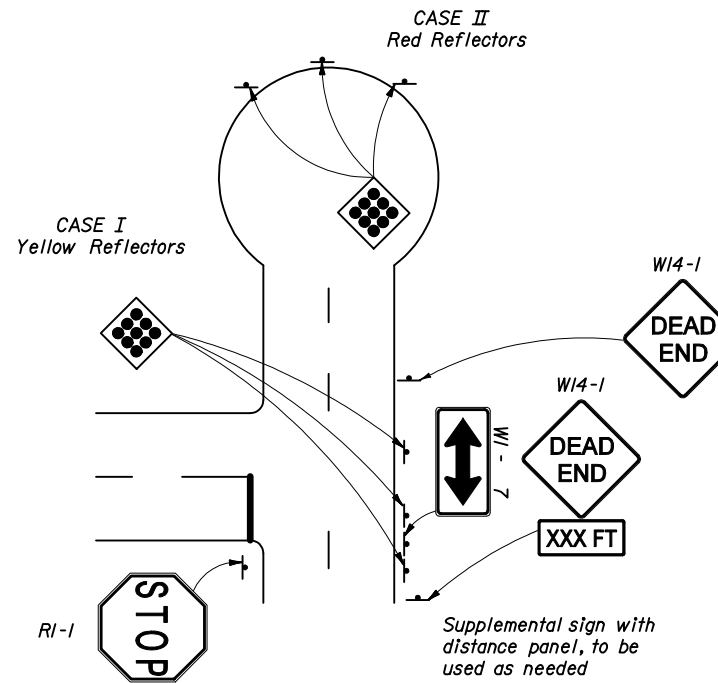
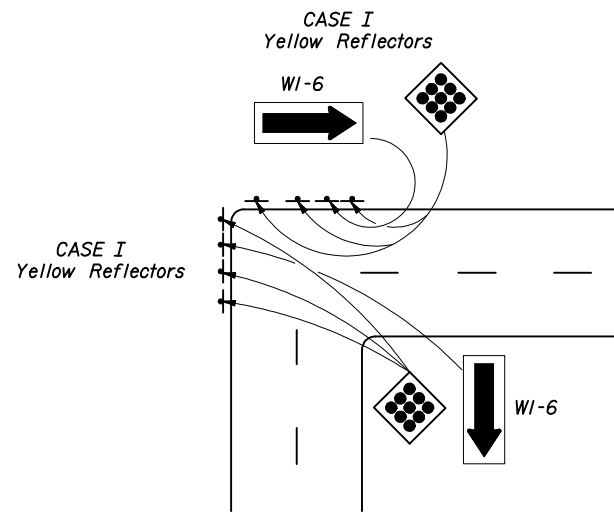

ONE WAY signs (R6-1) are not ordinarily needed at divided highway intersections with median widths of less than 30', and should be installed only if specifically called for in the plans.

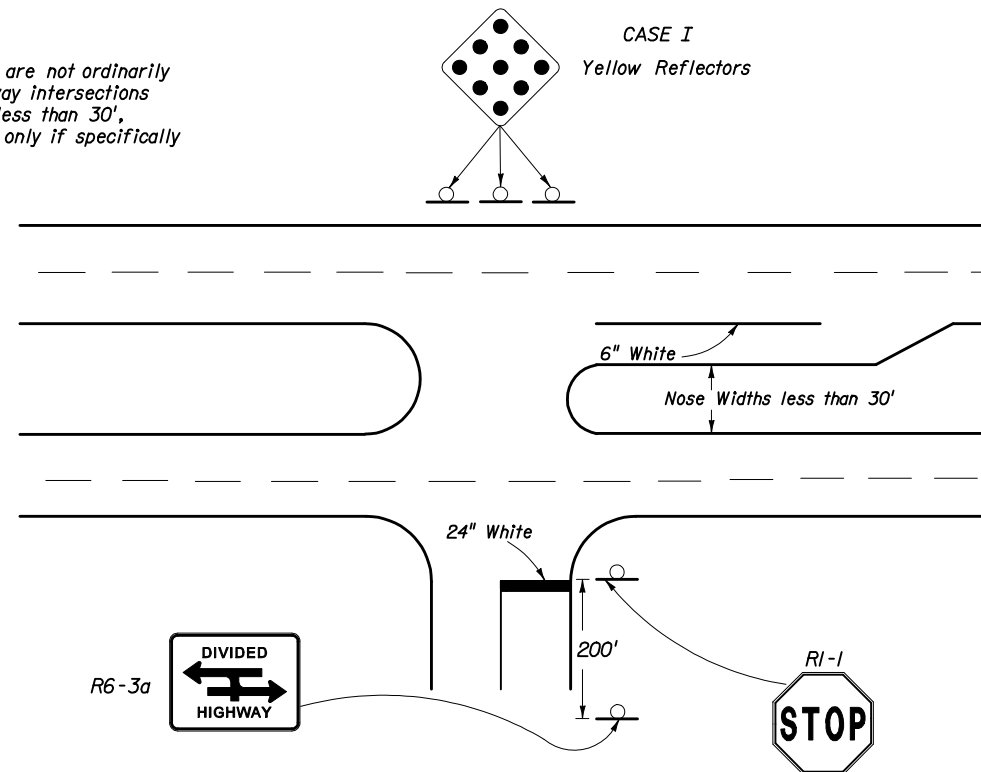
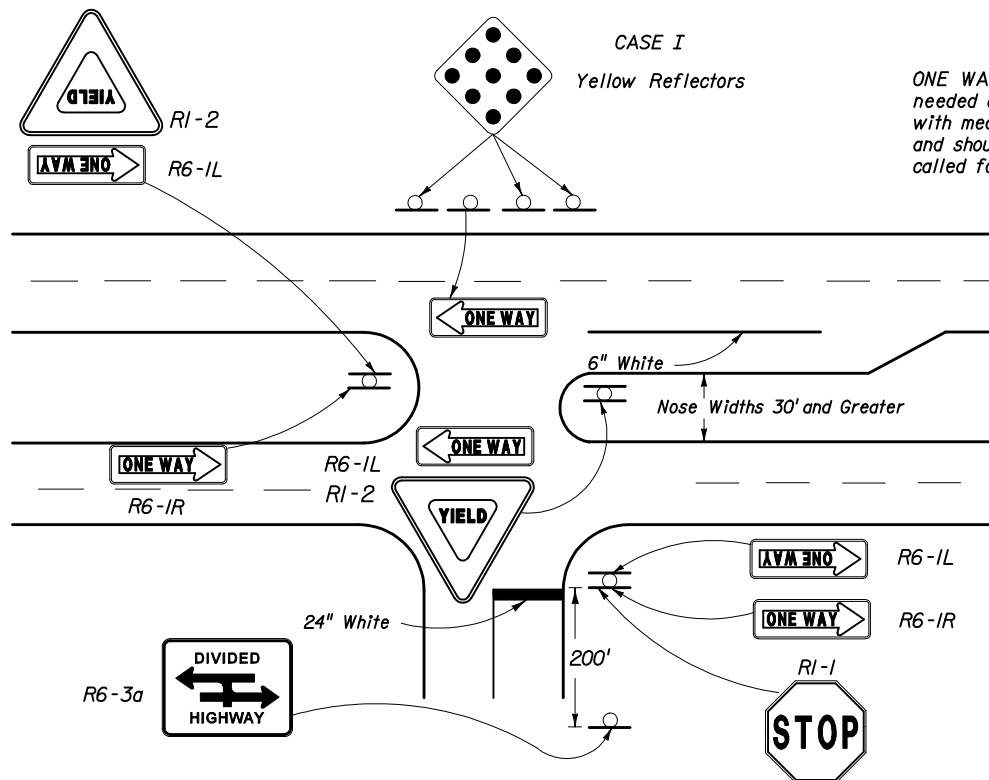

Supports shall be driven 3' into the ground.

2" \emptyset X $\frac{1}{8}$ " Aluminum Round Post or 2.5 #/Ft. Steel Flanged Channel Post.

Aluminum Post: $\frac{3}{8}$ " \emptyset Aluminum Button Head Bolt with Nut and Lockwasher or $\frac{1}{4}$ " \emptyset Stainless Steel Hex Head Bolt with Flat Washer under Head and Lockwasher under Nut.

Channel Post: Provide Attachment in Accordance with the "Sign Attachment Detail" on Index No. 11865.



2006 FDOT Design Standards

TRAFFIC CONTROLS FOR STREET TERMINATIONS

Last Revision 02
Sheet No. 1 of 1
Index No. 17349