

See Tables For Size And Number Of Wind Beams

See Backing Strip Details

Equal Spacing For Three, Four Or Five Windbeams

Two Wind beams - 21% D
Three Wind beams - 14.5% D
Four Wind beams - 10.7% D
Five Wind beams - 8.5% D

Aluminum Sign Panels 1/8" Thick

For Post Sizes, See Plans

Note: It shall be the contractors responsibility to determine the length of the column supports in the field prior to fabrication.

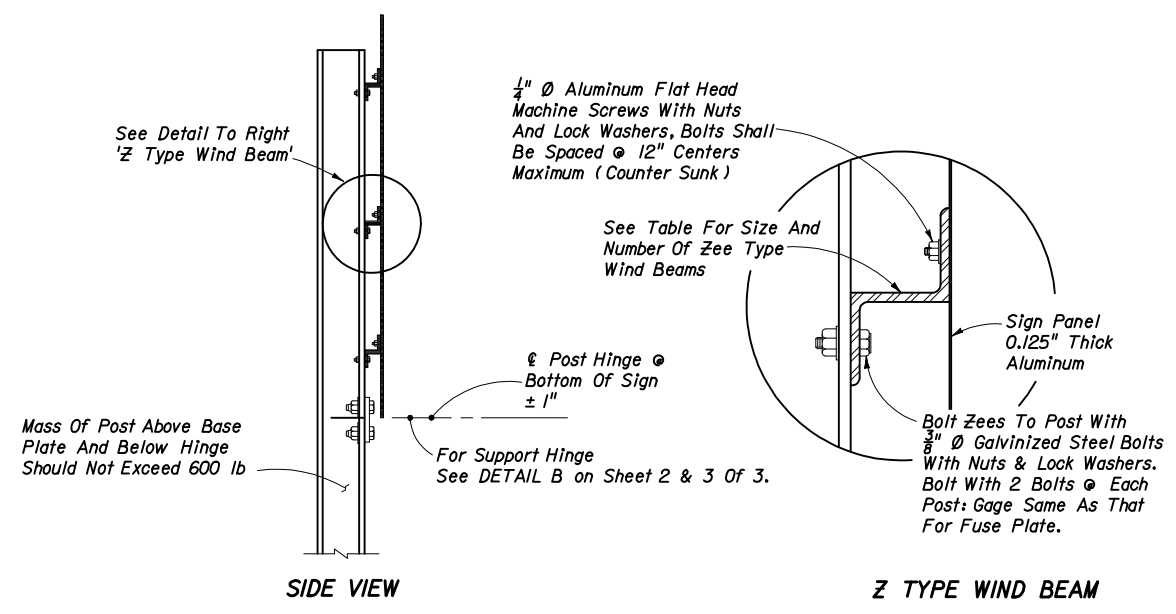
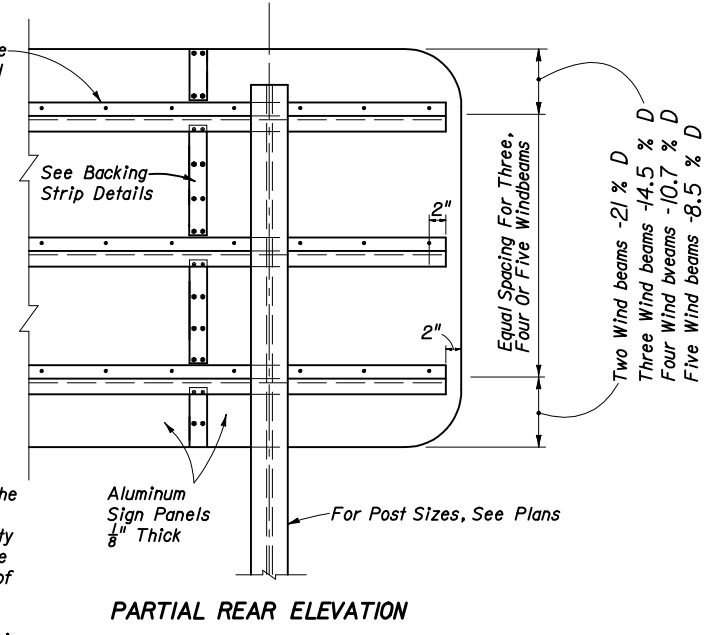

GENERAL NOTES

DESIGN WIND SPEEDS BY COUNTY

Note: If the sign panels are deeper than 12', a Horizontal Panel Splice is allowed at an interior Z bar support, shop drawings shall be required. Minimum panel section width = 2'-6" .

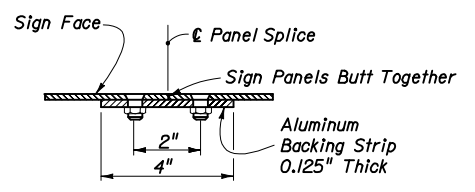

- ZONE NO. 1 (60 mph)**
Alachua, Baker, Bradford, Calhoun, Clay, Columbia, Gadsden, Gilchrist, Hamilton, Holmes, Jackson, Jefferson, Lafayette, Lake, Leon, Liberty, Madison, Marion, Putnam, Sumter, Suwannee, Union and Washington Counties.
- ZONE NO. 2 (70 mph)**
Bay, Citrus, Desoto, Dixie, Duval, Escambia, Flagler, Franklin, Glades, Gulf, Hardee, Hendry, Hernando, Highlands, Hillsborough, Levy, Nassau, Okaloosa, Okeechobee, Orange, Osceola, Pasco, Pinellas, Polk, Santa Rosa, Seminole, St. Johns, Taylor, Wakulla, and Walton Counties.
- ZONE NO. 3 (80 mph)**
Brevard, Charlotte, Collier, Indian River, Lee, Manatee, Martin, Palm Beach, Sarasota, St. Lucie, and Volusia Counties.
- ZONE NO. 4 (90 mph)**
Broward, Dade, and Monroe Counties

NUMBER OF WIND BEAMS FOR GIVEN DEPTH & WIND					
Wind	No. Beams	Max. Depth	Wind	No. Beams	Max. Depth
60	2	8'-0"	80	2	6'-8"
60	3	13'-4"	80	3	11'-4"
60	4	18'-0"	80	4	15'-4"
60	5	22'-8"	80	5	19'-0"
70	2	7'-0"	90	2	6'-0"
70	3	12'-0"	90	3	10'-4"
70	4	16'-4"	90	4	14'-0"
70	5	20'-8"	90	5	17'-8"

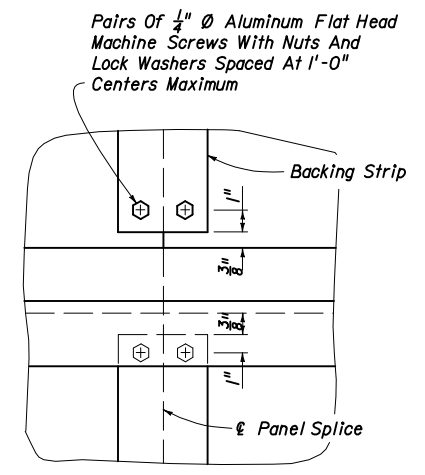

SIZE OF WIND BEAMS		
Size Of Zee*	Length Of Sign (Feet)	
	2 Posts	3 Posts
Z 1.75 x 1.75 x 1.08	0 - 11'-0"	0 - 17'-4"
Z 3 x 2.69 x 2.33	11'-1" - 19'-0"	17'-5" - 29'-6"
Z 3 x 2.69 x 3.38	19'-1" - 20'-8"	29'-7" - 31'-6"

*Note: Zees Are Aluminum - No Steel Equivalent Available
Designation Gives (Member Depth) x (Width) x (lb/ft)

- DESIGN SPECIFICATION** Standard Specification for Structural Supports for Highway Signs, Luminaries and Traffic Signals, AASHTO 1994. For welding refer to the latest editions of the AWS Structural Welding Codes for Steel and Aluminum, the AASHTO Standard Specifications for Welding Structural Steel Highway Bridges.
- DESIGN WIND LOAD** See Design Wind Speeds By County for wind in miles per hour on flat sign area. The allowable working stress shall be increased by 40% for combination dead load and wind load.
- ALUMINUM MATERIALS** All aluminum materials shall meet the requirements of the Aluminum Association's Alloy 6061-T6 and also the following ASTM specifications: Sheets and plates, B209; extruded tube, bars, rods & shapes, B221; and standard structural shapes, B308. Sheets are to be degreased, etched, neutralized and treated with Alodine 1200, Iridite 14-2, Bonderite 721, or equal. No stenciling permitted on sheets. Aluminum welding rods shall meet the requirements of Aluminum Association Alloy No. 5556 filler wire.
- STRUCTURAL STEEL** All structural steel shall meet the requirements of ASTM A36.
- ALUMINUM BOLTS, NUTS, & LOCKWASHERS** Aluminum bolts shall meet the requirements of Aluminum Association Alloy 2024-T4 (ASTM F468). The bolts shall have an anodic coating at least 0.0002" thick and be Chromate sealed. Lock washers shall meet the requirements of Aluminum Association Alloy 7075-T6 (ASTM B221). Nuts shall meet the requirements of Aluminum Association Alloy 6061-T6 or 6262-T9 (ASTM F467).
- STEEL BOLTS, NUTS, & WASHERS** All steel bolts, nuts and washers shall meet the requirements of ASTM A325.
- ALTERNATE MATERIAL** Material meeting the requirements of ASTM B209 or Aluminum Association Alloys 5154-H38 or 5052-H38 may be used for sheet and plate. Material meeting the requirements of Aluminum Association Alloy 6351-T5 and ASTM B221 may be used for extruded bars, rods, shapes and tubes.
- TOLERANCES** All above materials shall be in accordance with the governing ASTM specifications.
- GALVANIZING** All steel shapes, angles, tees, plates, bolts, nuts and washers shall be galvanized in accordance with Standard Specifications 962-7.
- BASE CONNECTION** High strength bolts L₂ in the base connection shall be tightened only to the torque shown in the tables on sheets 2 & 3 of 3. Overtightened base connections will not be accepted.
- FUSE PLATES** All holes in fuse plates shall be drilled. All plate cuts shall, preferably, be saw cuts; however, flame cutting will be permitted provided all edges are ground. Metal projecting beyond the plane of the plate face will not be tolerated.
- SIGN FACE** All sign face corners shall be rounded. See Sign Layout Sheet.
- SHOP DRAWINGS** When ground sign supports are fabricated in accordance with these plans no shop drawings are required. Shop drawings will be required for approval when the column length exceeds the length shown in the plans by more than 2'-0". However, shop drawings for sign panels, messages, lettering and quantities shall be submitted to traffic plans for approval.
- FABRICATOR NOTE** All bolted connections, except L₂ bolts and Zee to Post bolts, shall be high strength bolts. Bolts shall be tightened in the shop following a method approved by the engineer. Tightening shall be to such a degree so as to attain in each bolt the residual tension specified in the tabulation below:
- FOUNDATION** Contractor may use precast foundations in pre-drilled holes a minimum of 12" larger than the foundation indicated on the plans in either wet or dry conditions. The holes shall be clean and without loose material. Temporary casing shall be required if the soil is unstable. The holes shall be filled with flowable fill after the precast foundation is in place. The cost of flowable fill, installing and removal of casing shall be included in the unit price of Sign Multi-Post.

HIGH STRENGTH BOLTS (A-325)
MINIMUM RESIDUAL TENSION

BOLT SIZE	TENSION (lb)
5/8"	19,200
3/4"	28,400
7/8"	39,250
1"	51,500
1 1/8"	56,450
1 1/4"	71,700

SIGN PANEL AND WIND BEAMS

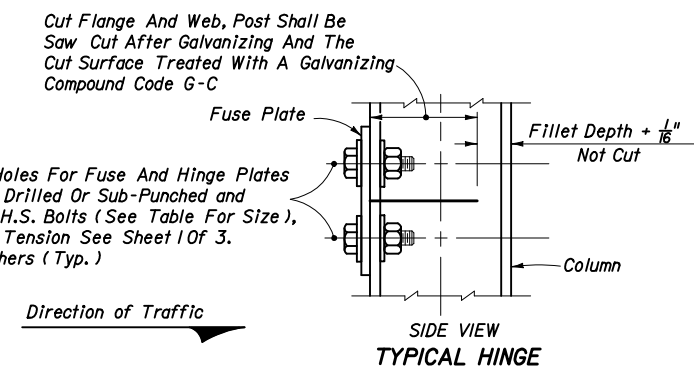
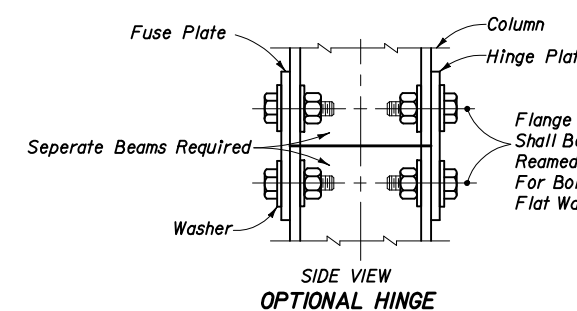
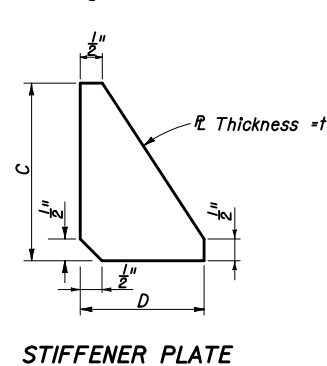
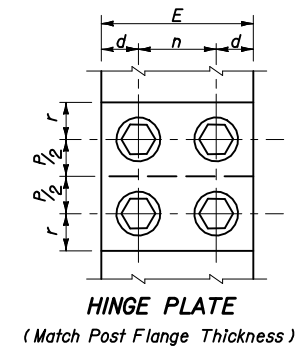
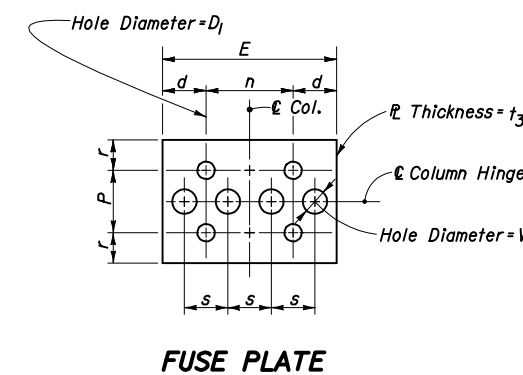
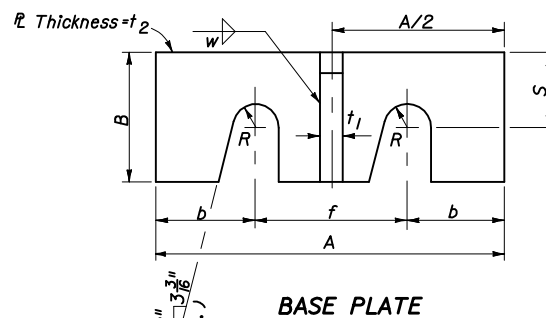
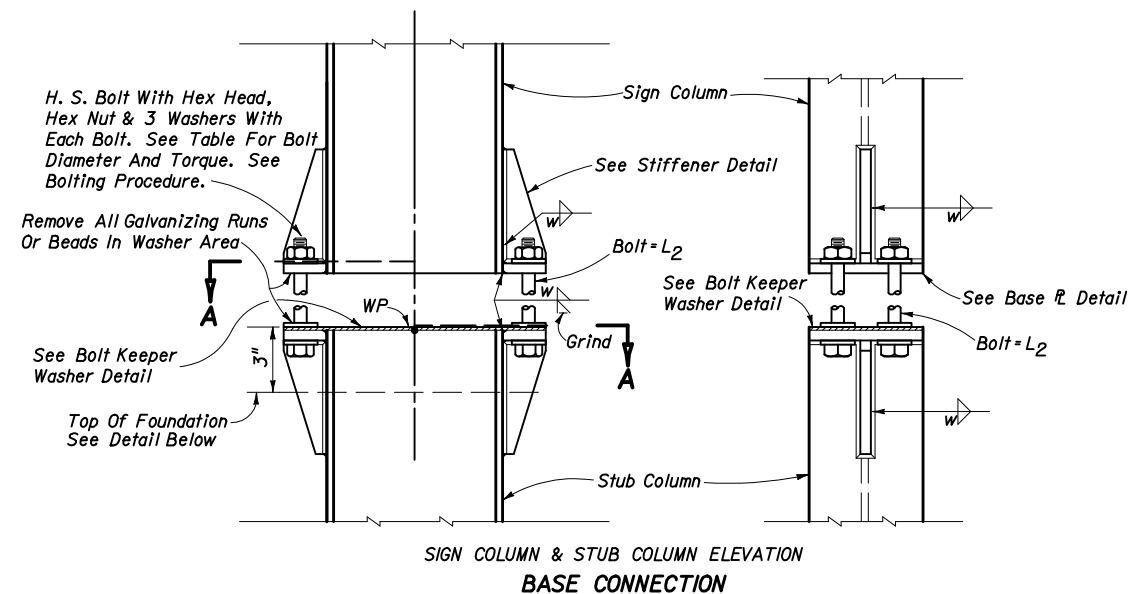
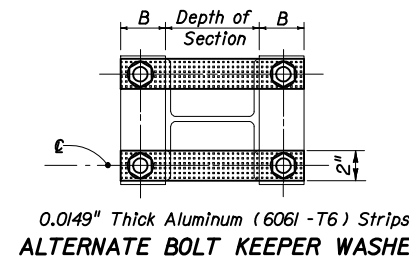
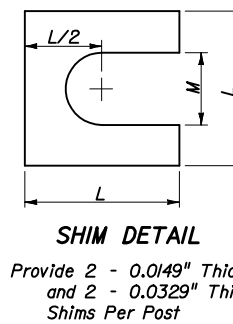
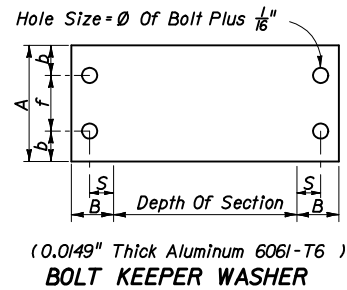
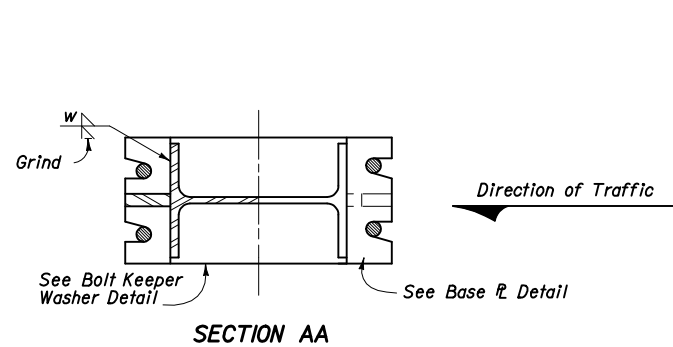

(See Fabricator Note On Sheet 1 of 3)
**FUSE & HINGE PLATES
 DETAIL B**

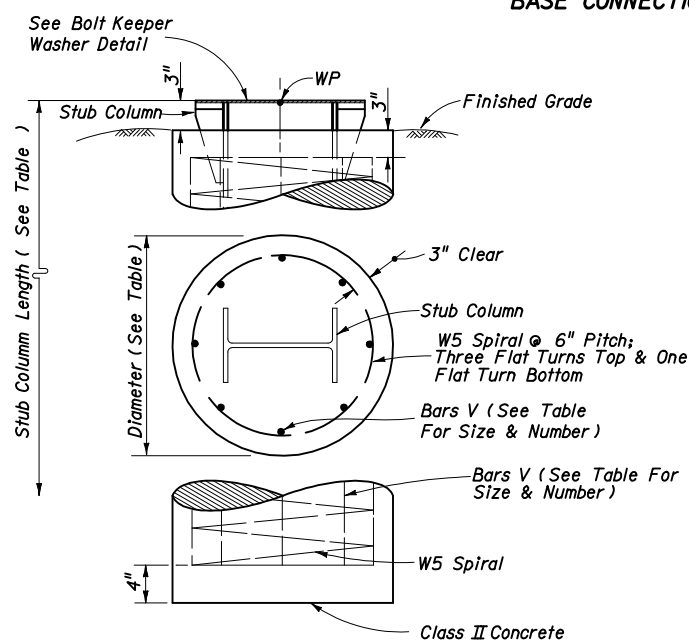

Section*	BASE CONNECTION DATA											FUSE (HINGE) PLATE DATA										FOUNDATION DATA				SHIM			
	A	B	C	D	Bolt Size (Lp) & Torque (in-lb)	R	b	f	S	t ₁	t ₂	w	Bolt Size	E	P	D ₁	d	n	r	s	t ₃	W	Dia.	Depth	Stub Length	Reinf. Bars V	L	M	
W 6x12	4 3/4"	2"	5 1/8"	2"	5/8" Ø 345	3/8"	1 1/8"	2 1/8"	1 3/8"	1/2"	1/2"	1/4"	5/8"	4 1/4"	3"	1 1/8"	1 1/8"	2"	1 3/8"	1"	1/2"	1 1/8"	1 1/8"	2'-0"	5'-6"	2'-4"	10-#6	1 3/8"	1 1/8"
W 8x18	5 3/4"	2 3/8"	6 1/4"	2 3/8"	3/4" Ø 550	7/16"	1 1/2"	2 3/4"	1 3/8"	1/2"	1/2"	1/4"	7/8"	5 1/2"	3 3/4"	1 5/8"	1 1/2"	2 1/2"	1 3/8"	1 1/2"	3/4"	1 1/8"	1 1/8"	2'-0"	7'-6"	2'-10"	10-#6	1 3/4"	1 3/8"
W 10x22	6 1/2"	2 3/4"	8"	2 3/4"	7/8" Ø 640	1/2"	1 1/8"	3"	1 3/8"	1/2"	1/2"	1/4"	1"	6 3/8"	4 1/2"	1 7/8"	1 3/4"	2 3/4"	1 3/4"	1 1/2"	3/4"	1 1/8"	1 1/8"	2'-4"	8'-6"	3'-4"	8-#8	2"	1 3/4"
W 10x33	8"	2 3/4"	8"	2 3/4"	1 1/8" Ø 780	5/8"	2"	4"	1 3/8"	1/2"	1/2"	1/4"	1 1/8"	7 1/8"	5 1/2"	1 3/8"	2 1/4"	3 3/8"	2"	1 3/8"	1/2"	1 1/8"	1 1/8"	2'-4"	10'-3"	4'-0"	8-#8	2 3/8"	1 3/8"
W 12x40	8"	3"	8"	3"	1 1/8" Ø 780	5/8"	2"	4"	1 3/8"	1/2"	1/2"	1/4"	1 1/4"	8 3/8"	5 3/4"	1 3/8"	2 1/4"	3 3/8"	2 3/8"	2"	1/2"	1 1/8"	1 1/8"	2'-8"	11'-3"	4'-8"	10-#8	2 3/8"	1 3/8"

* Designations Give (Nominal Depth) x (lb/ft)

PROCEDURE FOR ASSEMBLY OF BASE CONNECTION

1. Assemble post to stub with bolts and with one flat washer on each end bolt between plates.
2. Shim as required to plumb post (see shim detail).
3. Tighten all bolts the maximum possible with 1'-0" to 1'-3" wrench to bed washers and shims and to clean bolt threads then loosen each bolt in turn and retighten in a systematic order to the prescribed torque (see table).
4. Burr threads at junction with nut using a center punch to prevent nut loosening.

NOTE:
 Sections shown are for installation on right shoulder.
 For left shoulder plate slot bevels are opposite hand from that shown.

NOTE: All Reinforcing To Be Grade 60.

**STEEL POST, BASE,
 FOUNDATION & FUSE & HINGE PLATE DETAILS**



2006 FDOT Design Standards

STANDARD ROADSIDE SIGN

Last Revision	Sheet No.
07/01/05	3 of 3
Index No.	
11200	