

**DIVIDED ROADWAYS**

**GENERAL NOTES**

1. Roadway dimensions are representative. Subgrade dimensions and control lines are standard. The details shown on this Index do not supersede the details shown in the plans or on Index Nos. 500 or 506.
2. Plastic (P) soils may be placed above the existing water level (at the time of construction) to within 4 feet of the proposed base. It should be placed uniformly in the lower portion of the embankment for some distance along the project rather than full depth for short distances.
3. High Plastic (H) soils excavated within the project limits may be used in embankment construction as indicated on this index. High Plastic soils are not to be used for embankment construction when obtained from outside the project limits.
4. Select (S) soils having an average organic content of more than two and one-half (2.5) percent, or having an individual test value which exceeds four (4) percent, shall not be used in the subgrade portion of the roadbed.

Select (S), Plastic (P), or High Plastic (H) soils having an average organic content of more than five (5) percent, or an organic content individual test result which exceeds seven (7) percent, shall not be used in the portion of embankment inside the control line, unless written authorization is provided by the District Geotechnical Engineer; these soils may be used for embankment construction outside the control line, unless restricted by the plans or otherwise specified in the plans, provided they can be compacted sufficiently to sustain a drivable surface for operational vehicles as approved by the Engineer.

Average organic content shall be determined from the test results from a minimum of three randomly selected samples from each stratum or stockpile of a particular material. Tests shall be performed in accordance with AASHTO T 267 on the portion of a sample passing the No. 4 sieve.

5. Highly organic soils, composed primarily of partially decayed organic matter, often dark brown or black in color with an odor of decay, and sometimes fibrous, shall be designated as muck. Further, any stratum or stockpile of soil which contains pockets of highly organic material may be designated as Muck (M).

Highly organic soils shall not be used within the subgrade or embankment portion of the roadbed, with the exception of muck used as a supplement to construct a finish soil layer as described in Section 162 of the FDOT Standard Specifications.

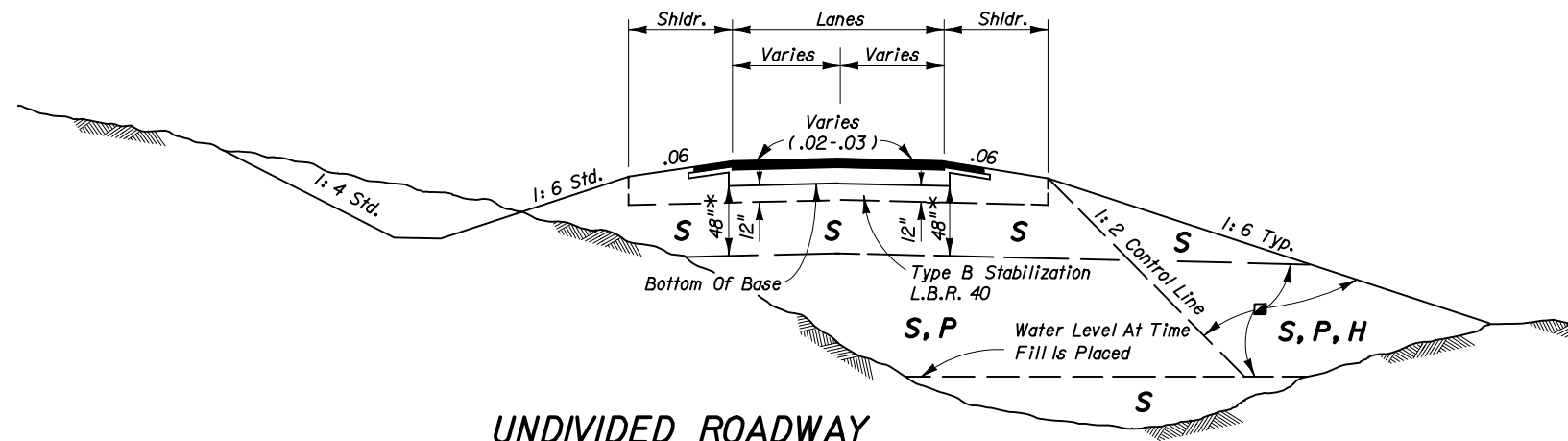

**UNDIVIDED ROADWAY**

**DESIGN NOTES**

1. The designer shall take into consideration the expectancy of roadway widening to the outside, and where widening is anticipated, specify in the plans the location of the future widening control line for utilization of High Plastic (H) soils and/or soils classified as organic material in the embankment.
2. The designer shall take into consideration the position of the drainage swales in the portion of the embankment where Plastic (P) soils, High Plastic (H) soils, or soils classified as organic material would be allowed. The designer shall limit the use of Plastic (P) soils, High Plastic (H) soils, and/or soils classified as organic material to locations that will not inhibit the infiltration of stormwater from the swales.

SYMBOL	SOIL	CLASSIFICATION (AASHTO M 145)
S	Select	A-1, A-3, A-2-4 **
P	Plastic	A-2-5, A-2-6, A-2-7, A-4, A-5, A-6, A-7 (ALL WITH LL < 50)
H	High Plastic	A-2-5, A-2-7, A-5 Or A-7 (ALL WITH LL > 50)
M	Muck	A-8

Classification listed left to right in order of preference.

See General Notes Nos. 4 & 5 for utilization of soils classified as organic material or muck.

\*\* Certain types of A-2-4 material are likely to retain excess moisture and may be difficult to dry and compact. They should be used in the embankment above the water level existing at time of construction. They may be used in the subgrade portion of the roadbed when approved by the District Materials Engineer. A-2-4 material placed below the existing water level must be non-plastic and contain less than 15% passing the No. 200 U.S. Standard sieve.

\* For cut sections this dimension may be reduced to 24"; see Index No. 500. For minor collectors and local facilities this dimension may be reduced to 18".

**FLEXIBLE PAVEMENT**

STATE OF FLORIDA DEPARTMENT OF TRANSPORTATION

**EMBANKMENT UTILIZATION**

Names	Dates	Approved By		
Designed By	GEOTECH 09/93	 State Geotechnical Engineer		
Drawn By	HSD 09/93			
Checked By	BTD 09/93	Revision	Sheet No.	Index No.
		04	1 of 3	505

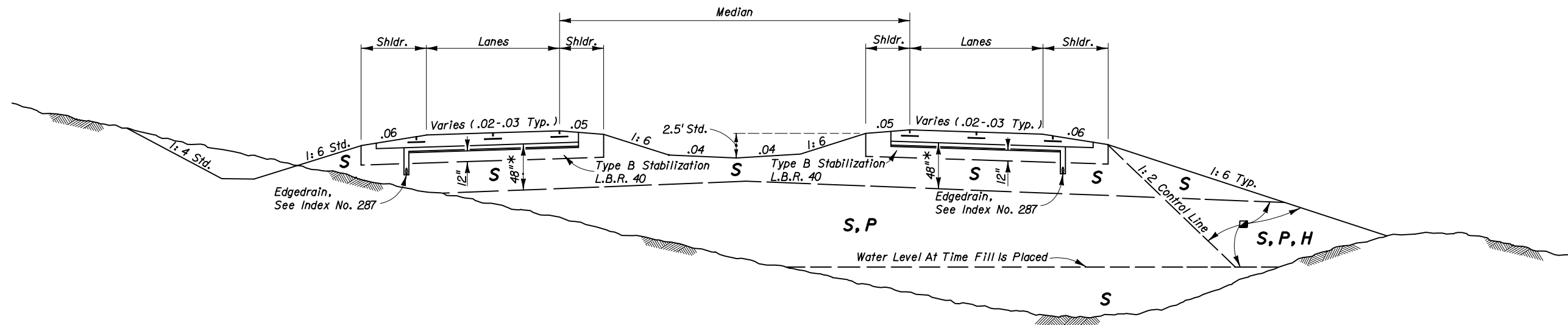

**DIVIDED ROADWAYS**

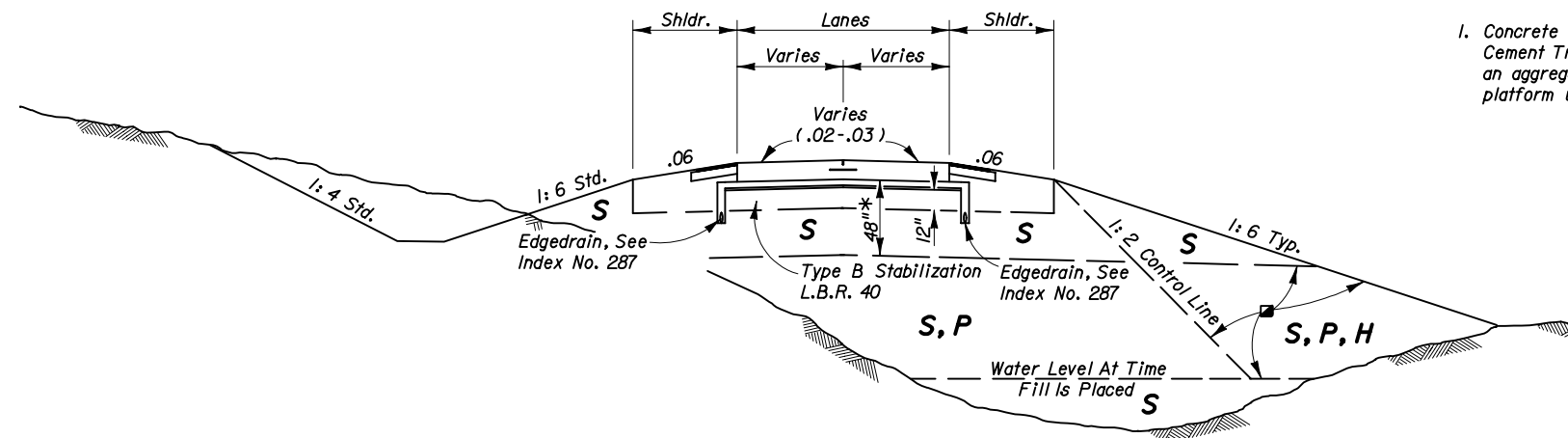

**UNDIVIDED ROADWAY**

**DESIGN NOTE**

1. Concrete pavement is to be placed over 4" of Asphalt Treated Permeable Base (ATPB) or Cement Treated Permeable Base (CTPB) as identified in the plans. This will be placed on an aggregate separator layer using 1" Type SP (Traffic C). This will be placed on a working platform using 12" of Type B Stabilization.

SYMBOL	SOIL	CLASSIFICATION (AASHTO M 145)
S	Select	A-1, A-3, A-2-4 **
P	Plastic	A-2-5, A-2-6, A-2-7, A-4, A-5, A-6, A-7 (ALL WITH LL < 50)
H	High Plastic	A-2-5, A-2-7, A-5 Or A-7 (ALL WITH LL > 50)
M	Muck	A-8

Classification listed left to right in order of preference.

- ☑ See General Notes Nos. 4 & 5 for utilization of soils classified as organic material or muck.
- \*\* Certain types of A-2-4 material are likely to retain excess moisture and may be difficult to dry and compact. They should be used in the embankment above the water level existing at time of construction. They may be used in the subgrade portion of the roadbed when approved by the District Materials Engineer. A-2-4 material placed below the existing water level must be non-plastic and contain less than 15% passing the No. 200 U.S. Standard sieve.
- \* For cut sections this dimension may be reduced to 24"; see Index No. 500. For minor collectors and local facilities this dimension may be reduced to 18".

**RIGID PAVEMENT - TREATED PERMEABLE BASE OPTION**

STATE OF FLORIDA DEPARTMENT OF TRANSPORTATION

**EMBANKMENT UTILIZATION**

Names	Dates	Approved By
Designed By: HMD	09/93	State Geotechnical Engineer
Drawn By: HSD	09/93	
Checked By: BTD	09/93	
Revision	Sheet No.	Index No.
04	2 of 3	505

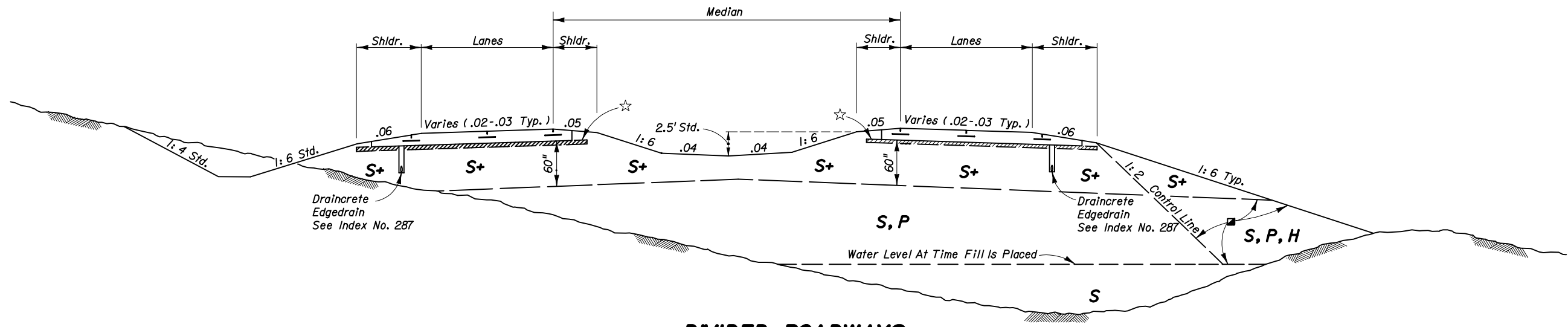

**DIVIDED ROADWAYS**

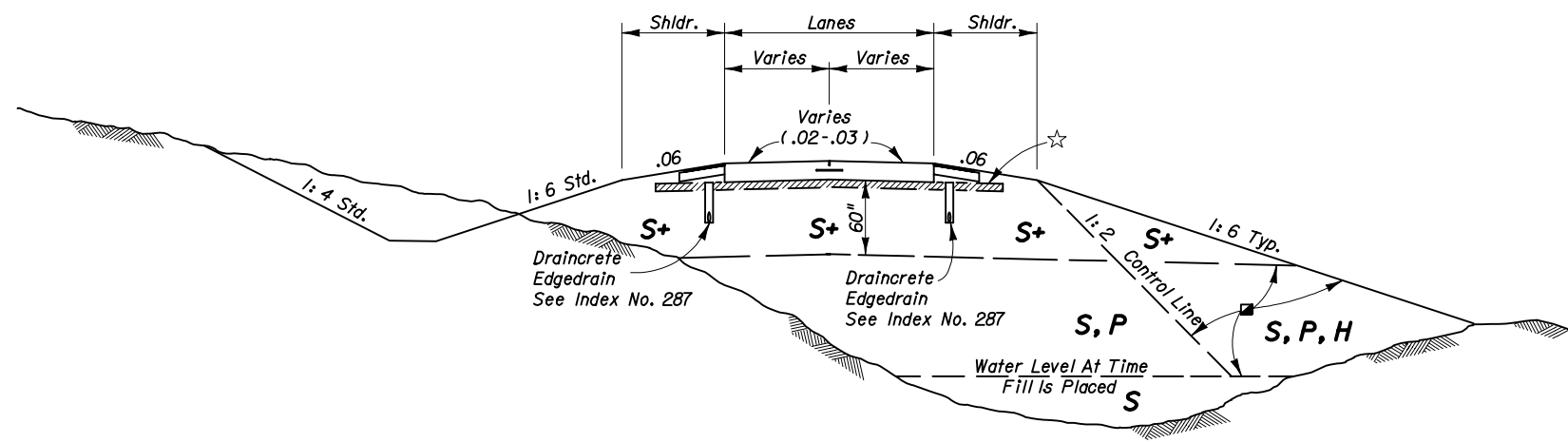

**UNDIVIDED ROADWAY**

SYMBOL	SOIL	CLASSIFICATION (AASHTO M 145)
S	Select	A-1, A-3, A-2-4 **
S+	Special Select	A-3 *** With Minimum Average Lab Permeability of $5 \times 10^{-5}$ cm/sec (0.14 ft./day) as per FM 1-T215
P	Plastic	A-2-5, A-2-6, A-2-7, A-4, A-5, A-6, A-7 (ALL WITH LL < 50)
H	High Plastic	A-2-5, A-2-7, A-5 Or A-7 (ALL WITH LL > 50)
M	Muck	A-8

Classification listed left to right in order of preference.

See General Notes Nos. 4 & 5 for utilization of soils classified as organic material or muck.

\*\*\* When allowed by the plans, some types of A-2-4 material may be approved in writing by the District Materials Engineer. This material must meet the minimum lab permeability requirement, be non-plastic, and not exceed 12% passing the No. 200 U.S. Standard sieve.

\*\* Certain types of A-2-4 material are likely to retain excess moisture and may be difficult to dry and compact. They should be used in the embankment above the water level existing at time of construction. A-2-4 material placed below the existing water level must be non-plastic and contain less than 15% passing the No. 200 U.S. Standard sieve.

☆ 3" of #57 Coarse Aggregate Mixed Into Top 6".

Note: SPECIAL SELECT SOIL OPTION may be used only when approved in writing by the District Materials Engineer and shown in the plans.

**RIGID PAVEMENT - SPECIAL SELECT SOIL OPTION**

STATE OF FLORIDA DEPARTMENT OF TRANSPORTATION

**EMBANKMENT UTILIZATION**

Names	Dates	Approved By		
Designed By	HMD 09/93	 State Geotechnical Engineer		
Drawn By	HSD 09/93			
Checked By	BTD 09/93	Revision	Sheet No.	Index No.
		04	3 of 3	505