

TAI

The Reinforced Earth Company

8614 WESTWOOD CENTER DRIVE SUITE 1100, VIENNA VIRGINIA 22182 (703) 821-1175

DESIGN CRITERIA

1. DESIGN IS BASED ON THE ASSUMPTION THAT THE MATERIAL WITHIN THE REINFORCED EARTH VOLUME, METHODS OF CONSTRUCTION AND QUALITY OF PREFABRICATED MATERIALS SHALL CONFORM TO THE CONTRACTING AGENCY'S TECHNICAL SPECIFICATIONS (SECTION 548) FOR REINFORCED EARTH WALLS
2. SOIL PARAMETERS:

SEE WALL CONTROL DRAWINGS FOR SOIL CHARACTERISTICS OF FOUNDATION MATERIAL TO BE USED IN THE DESIGN OF THE WALL SYSTEM. THE CONTRACTOR SHALL PROVIDE SOIL DESIGN PARAMETERS FOR BACKFILL MATERIAL BASED ON THE ACTUAL SOIL CHARACTERISTICS UTILIZED AT THE SITE. THE VALUES OF FRICTION ANGLE (ϕ), COHESION (c) AND TOTAL UNIT WEIGHT (γ) SHALL BE PROVIDED IN THE SHOP DRAWINGS.
3. THE MAXIMUM APPLIED BEARING PRESSURE AT THE FOUNDATION LEVEL IS AS SHOWN ON THE WALL ELEVATIONS FOR EACH DESIGN CASE. IT IS THE RESPONSIBILITY OF THE OWNER TO DETERMINE THAT THIS APPLIED BEARING PRESSURE IS ALLOWABLE FOR THAT LOCATION.
4. ANY UNSUITABLE FOUNDATION MATERIAL BELOW THE REINFORCED EARTH VOLUME, AS DETERMINED BY THE ENGINEER, SHALL BE EXCAVATED AND REPLACED WITH SUITABLE MATERIAL OR OTHERWISE STABILIZED AS DIRECTED BY THE ENGINEER.
5. REINFORCING STRIPS FOR REINFORCED EARTH WALLS SHALL BE 1³/₂" WIDE AND 7/32" THICK, AND SHALL CONFORM TO THE PHYSICAL AND MECHANICAL PROPERTIES OF ASTM A-572 GRADE 65. GALVANIZATION SHALL BE APPLIED IN ACCORDANCE WITH ASTM A-123.
6. THE MINIMUM FACTORS OF SAFETY REQUIRED FOR DESIGN

OVERTURNING = 2.0
 SLIDING = 1.5
 INTERNAL PULLOUT = 1.5
 (ALLOWABLE DEFORMATION = 0.75 INCH)
 BEARING CAPACITY = 2.5
 OVERALL STABILITY = 1.5
 STEEL SOIL REINFORCEMENT = 0.55F_y AT END OF DESIGN LIFE AND 0.50 F_u AT NET SECTION OF BOLTED CONNECTION
 MAXIMUM PULLOUT FACTOR f* (FOR SAND) = 1.5
 (FOR LIMEROCK) = 2.0

WALL CONSTRUCTION

7. REINFORCED EARTH WALLS IN CURVES WILL FORM A SERIES OF SHORT CHORDS OF 4'-11" EACH TO MATCH DESIRED WALL ALIGNMENT.
8. FOR LOCATION AND ALIGNMENT OF REINFORCED EARTH WALLS, SEE RETAINING WALL CONTROL PLANS.
9. IF MANHOLES AND DROP INLETS ARE PRESENT, THEY SHALL BE LOCATED AS SHOWN ON WALL ELEVATIONS.
10. IF PILES ARE LOCATED WITHIN THE REINFORCED EARTH VOLUME, THEY SHALL BE DRIVEN PRIOR TO CONSTRUCTION OF THE REINFORCED EARTH WALL UNLESS A METHOD TO PROTECT THE STRUCTURE, WHICH IS ACCEPTABLE TO THE ENGINEER AND THE REINFORCED EARTH COMPANY, AND IS PROPOSED AND APPROVED IN WRITING.

11. BACKFILL MATERIAL SHALL BE COMPACTED IN ACCORDANCE WITH SEC 548 TO A LEVEL OF 2" ± ABOVE THE TIE STRIPS EMBEDDED IN THE PANELS. INSTALLATION OF REINFORCING STRIPS SHALL BE PERMITTED ONLY AFTER PLACEMENT AND COMPACTION OF THE BACKFILL MATERIAL HAS REACHED THE REQUIRED LEVEL.
12. IF STRUCTURES IN EXCESS OF 20' IN HEIGHT OCCUR, THE FINISHED GRADE IN FRONT OF THE WALL SHALL BE PLACED AND COMPACTED BEFORE WALL CONSTRUCTION EXCEEDS A HEIGHT OF 20'. FINISHED GRADE BACKFILL SHALL BE COMPACTED TO 95% OF AASHTO T-180 UNLESS OTHERWISE DIRECTED BY THE ENGINEER.
13. IT IS THE CONTRACTOR'S RESPONSIBILITY TO DETERMINE THE LOCATION OF ANY GUARDRAIL POSTS BEHIND THE REINFORCED EARTH PANELS PRIOR TO PLACEMENT OF THE TOP LAYER OF REINFORCING STRIPS. INDIVIDUAL STRIPS MAY BE SKEWED UP TO 15° TO AVOID THE POST LOCATIONS IF AUTHORIZED BY THE ENGINEER. ANY DAMAGE DONE TO THE REINFORCING STRIPS DUE TO THE INSTALLATION OF THE GUARDRAIL SHALL BE REPAIRED BY THE CONTRACTOR AT THE CONTRACTOR'S EXPENSE.
14. IF EXISTING OR FUTURE STRUCTURES, PIPES, FOUNDATIONS OR GUARDRAIL POSTS WHICH ARE WITHIN THE REINFORCED EARTH VOLUME INTERFERE WITH THE NORMAL PLACEMENT OF REINFORCING STRIPS AND SPECIFIC DIRECTION HAS NOT BEEN PROVIDED ON THE PLANS, THE CONTRACTOR SHALL NOTIFY THE ENGINEER TO DETERMINE WHAT COURSE OF ACTION SHOULD BE TAKEN.
15. TOP PANELS BENEATH COPING SHALL HAVE #4 DOWELS PROTRUDING FROM THEIR TOP EDGE.
16. FOR OTHER INFORMATION PERTAINING TO WALL CONSTRUCTION PLEASE REFER TO THE REINFORCED EARTH CONSTRUCTION MANUAL.
17. THE CONTRACTOR IS RESPONSIBLE FOR GRADUALLY DEFLECTING UPPER REINFORCING STRIPS DOWNWARD TO AVOID CONFLICTS WITH PAVING AND SUBGRADE PREPARATION. THE CONTRACTOR'S ATTENTION IS DIRECTED ESPECIALLY TO SITUATIONS WHERE ROADWAY SUPERELEVATION AND/OR SOIL MIXING ARE ANTICIPATED.

MATERIALS NOTES

18. NOMINAL STRIP LENGTHS

THE REINFORCING STRIP LENGTHS SHOWN ON THE PLANS, MEASURED FROM BACK FACE OF PANEL, ARE THE NOMINAL LENGTHS REQUIRED BY CALCULATION. THE ACTUAL FABRICATED STRIP LENGTHS ARE OFTEN LONGER (UP TO 6") DUE TO MANUFACTURING TOLERANCES. THE REQUIRED HORIZONTAL LIMIT OF GRANULAR BACKFILL IS EQUAL TO THE NOMINAL STRIP LENGTH.
19. PANEL FINISH

THE PRECAST PANELS FOR THIS PROJECT SHALL HAVE A PLAIN STEEL FINISH UNLESS OTHERWISE SPECIFIED ON THE RETAINING WALL CONTROL PLANS.

20. NOTE TO CONTRACTORS

ONLY THE FOLLOWING MATERIALS ARE SUPPLIED BY THE REINFORCED EARTH COMPANY:

- PRECAST CONCRETE FACING PANELS
- REINFORCING STRIPS
- BOLT SETS (FOR ATTACHING PANELS TO THE REINFORCING STRIPS)
- BEARING BLOCKS
- RUBBER SHIMS
- FILTER CLOTH AND ADHESIVE (FOR PANEL JOINTS ONLY)

ANY OTHER MATERIALS CALLED FOR IN THE CONTRACT PLANS OR SPECIFICATIONS ARE TO BE SUPPLIED BY THE CONTRACTOR. ANY JOINT MATERIALS SHOWN AT THE INTERFACE OF PRECAST PANELS AND CAST-IN-PLACE CONCRETE STRUCTURES ARE TO BE SUPPLIED BY THE ERECTION CONTRACTOR. ALL SANDBLASTING, PAINTING, SEALERS OR OTHER SPECIAL APPLIED COATINGS ARE ALSO SUPPLIED/INSTALLED BY THE CONTRACTOR IN THE FIELD FOLLOWING PANEL ERECTION.

21. THE REINFORCED EARTH COMPANY SUPPLIES PRECAST CONCRETE FACING PANELS AND ACCESSORIES TO BE USED IN CONJUNCTION WITH OTHER MATERIALS IN THE CONSTRUCTION OF THE REINFORCED EARTH® RETAINING WALLS DETAILED HEREIN. THE CONSTRUCTION AND QUALITY CONTROL PROCEDURES MANUAL FURNISHED BY THE REINFORCED EARTH COMPANY IS INTENDED TO PROVIDE A GENERAL EXPLANATION OF THE SYSTEM. IT IS THE CONTRACTOR'S OBLIGATION TO DEVISE AND EXECUTE A PROJECT SPECIFIC ERECTION SEQUENCE, PANEL UNLOADING, HANDLING AND BRACING SYSTEM, AND FALL PROTECTION SYSTEM. THE BRACING SYSTEM SHOWN IN THE CONSTRUCTION AND QUALITY CONTROL PROCEDURES MANUAL IS GENERAL IN NATURE AND DOES NOT ACCOUNT FOR PROJECT SPECIFIC CRITERIA. COMPLIANCE WITH THE GUIDELINES IN THIS MANUAL DOES NOT RELIEVE THE CONTRACTOR OF ITS RESPONSIBILITY TO ADHERE TO THE PROJECT PLANS, SPECIFICATIONS AND CONTRACT DOCUMENTS OR COMPLIANCE WITH ALL FALL PROTECTION, SAFETY, LAWS, STANDARDS AND PROCEDURES AT THE JOBSITE. CONTRACTORS SHOULD TAKE SPECIAL PRECAUTIONS TO PREVENT THE PANELS FROM SHIFTING OR FALLING DURING THE ERECTION PROCESS.
22. THE DESIGN CONTAINED ON THESE DRAWINGS IS BASED ON INFORMATION PROVIDED BY THE OWNER. ON THE BASIS OF THIS INFORMATION, THE REINFORCED EARTH COMPANY IS RESPONSIBLE FOR INTERNAL STABILITY OF THE STRUCTURE ONLY. EXTERNAL STABILITY DESIGN INCLUDING FOUNDATION AND SLOPE STABILITY IS THE RESPONSIBILITY OF OTHERS.
23. THESE DRAWINGS ARE CERTIFIED WITH RESPECT TO THE INTERNAL STABILITY OF REINFORCED EARTH STRUCTURES ONLY
24. THIS DRAWING CONTAINS INFORMATION PROPRIETARY TO THE REINFORCED EARTH COMPANY, AND IS BEING FURNISHED FOR THE USE IN CONNECTION WITH FDOT PROJECTS ONLY, AND THE INFORMATION CONTAINED HEREIN IS NOT TO BE TRANSMITTED TO ANY OTHER ORGANIZATION UNLESS SPECIFICALLY AUTHORIZED IN WRITING BY THE REINFORCED EARTH COMPANY. THE REINFORCED EARTH COMPANY IS EXCLUSIVE LICENSEE IN THE UNITED STATES UNDER PATENTS ISSUED TO HENRY VIDAL, AND THE FURNISHING OF THIS DRAWING DOES NOT CONSTITUTE AN EXPRESSED OR IMPLIED LICENSE UNDER THE VIDAL PATENTS.

THIS SYSTEM SHALL BE USED IN SLIGHTLY OR MODERATELY AGGRESSIVE ENVIRONMENTS ONLY
CRUCIFORM AND SQUARE PANELS

STATE OF FLORIDA DEPARTMENT OF TRANSPORTATION

RETAINING WALL SYSTEM REINFORCED EARTH COMPANY REINFORCED EARTH WALL

Names	Dates	Approved By		
Designed By		 State Structures Design Engineer	Revision	Sheet No.
Drawn By			00	1 of 14
Checked By				Index No. 5015

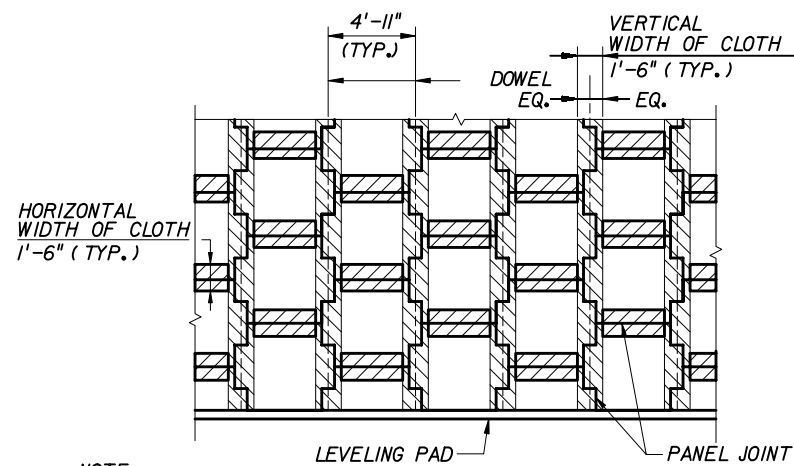

NOTE:
STRIPS OF FILTER CLOTH SHALL BE PLACED ON BACK FACE OF PANEL, OVER PANEL JOINTS. FILTER CLOTH SHALL BE ADHERED TO BACK FACE OF PANELS USING AN ADHESIVE COMPOUND SUPPLIED BY THE REINFORCED EARTH COMPANY. ADHESIVE SHALL BE APPLIED TO PANEL THEN FILTER CLOTH (CARTHAGE MILLS TYPE FX-40HS OR EQUAL) SHALL BE APPLIED TO PANELS.

**FILTER CLOTH DETAIL
PARTIAL ELEVATION - BACK FACE**

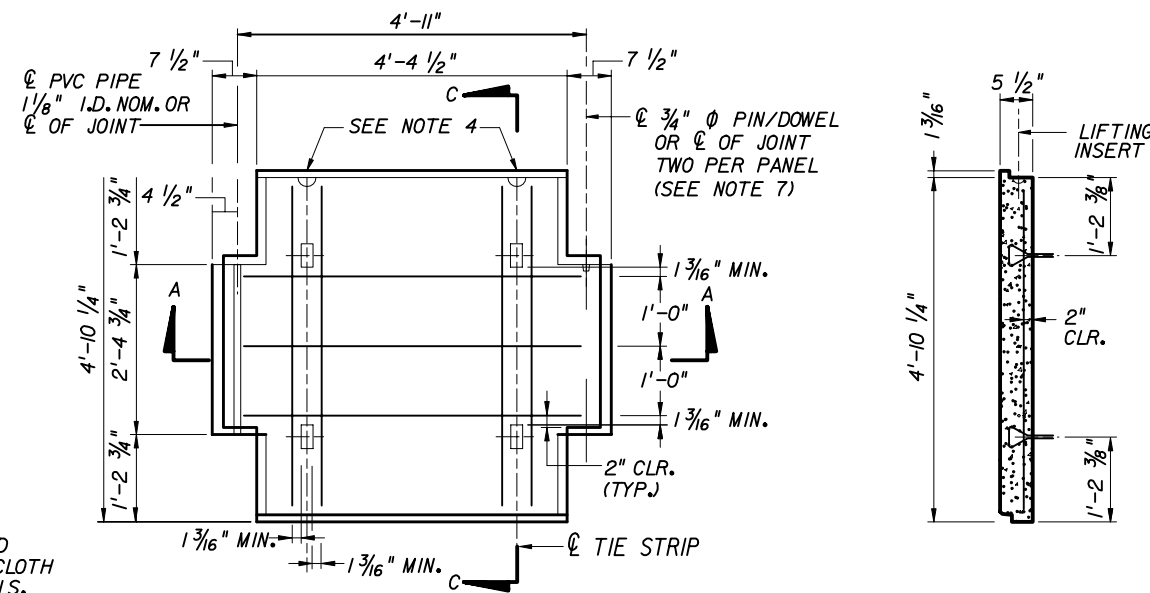

**PANEL TYPE "A"
WITH R4 REINFORCEMENT
FRONT VIEW**

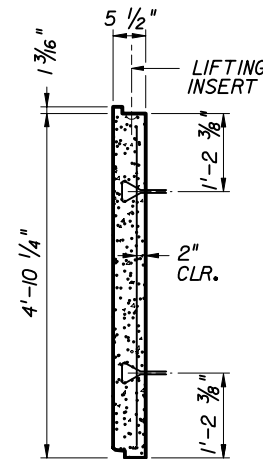

SECTION C-C

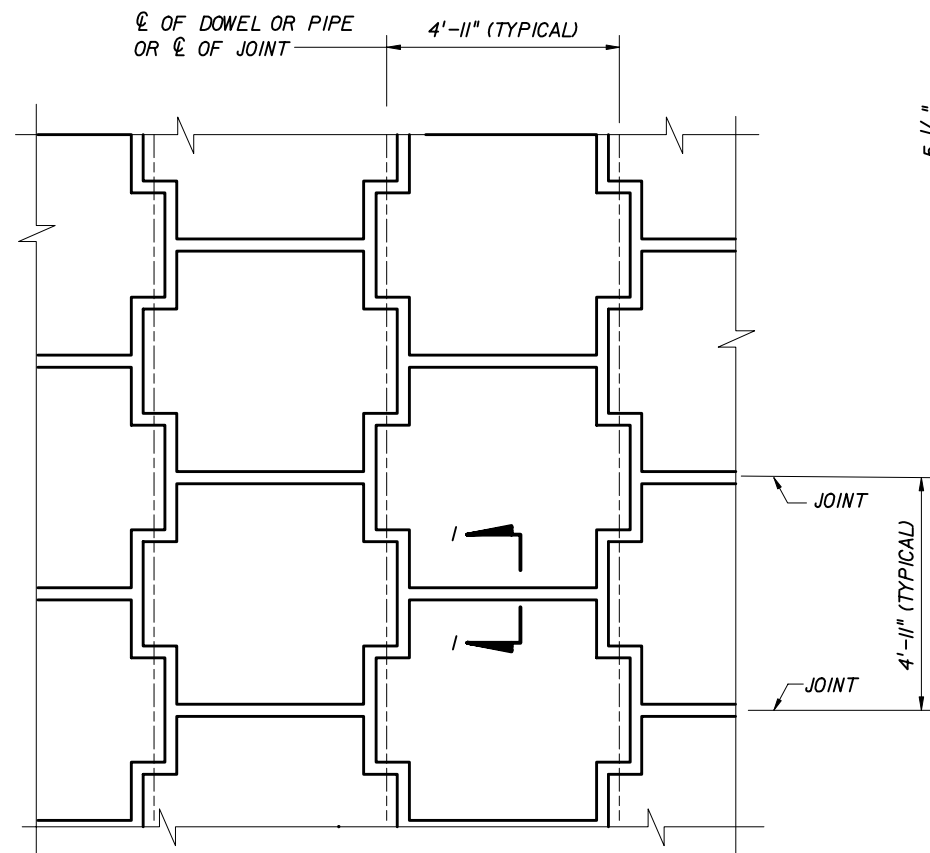

**TYPICAL PANEL LAYOUT
PARTIAL ELEVATION - FRONT FACE**

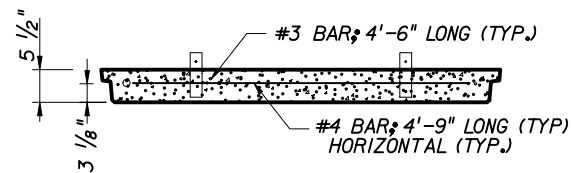

SECTION A-A

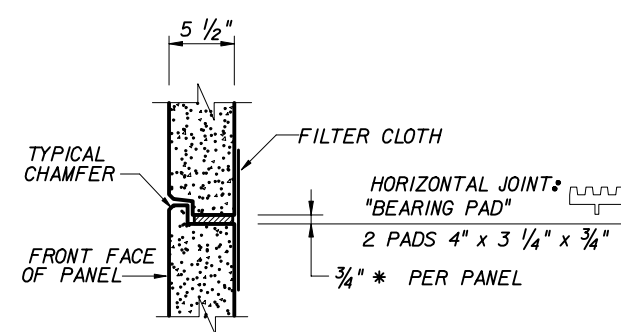

SECTION I-I

PANEL THICKNESS	REINFORCEMENT DESIGNATION	* PANEL REINFORCEMENT (IN ²)	MAXIMUM ALLOWABLE HORIZONTAL STRESS AT FACING (KPA)
5 1/2"	R4	0.44 VERTICAL 0.58 HORIZONTAL	1.19
	R6	0.66 VERTICAL 0.78 HORIZONTAL	1.46
	R7	1.18 VERTICAL 1.78 HORIZONTAL	2.58

* TOTAL AREA OF STEEL REQUIRED PER "TYPE A" PANEL.

NOTES:

1. REINFORCING STEEL TO BE A615 GRADE 60.
2. 3/8" x 3/8" CHAMFER SHALL BE PROVIDED ON ALL EXPOSED EDGES (FRONT FACE ONLY).
3. ALL PANEL TYPES AND OTHER RELATED ELEMENTS WILL BE DETAILED ON SHOP DRAWINGS.
4. ALL PANELS SHALL HAVE TWO LIFTING INSERTS OF ONE TON CAPACITY EACH.
5. PANEL DESIGN THICKNESS IS 5 1/2". THICKNESS OF CONCRETE MUST INCREASE TO ACCOMMODATE ANY ARCHITECTURAL SURFACE FINISH THAT MAY BE SPECIFIED.
6. ACTUAL PANEL REINFORCEMENT FOR ALL PANEL TYPES ON THIS PROJECT IS DESIGNATED ABOVE. R4 ILLUSTRATED FOR INFORMATION ONLY.
7. EACH 3/4" Ø DOWEL SHALL HAVE A TYP. LENGTH OF 10". DOWELS MAY BE GALVANIZED STEEL OR PVC ROD. A SINGLE FULL LENGTH DOWEL MAY BE USED AT THE DISCRETION OF THE MANUFACTURER.

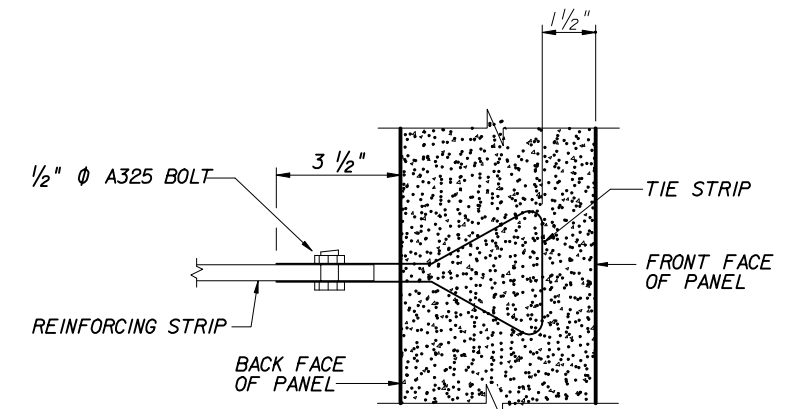

CONNECTION DETAIL

THIS SYSTEM SHALL BE USED IN SLIGHTLY OR MODERATELY AGGRESSIVE ENVIRONMENTS ONLY
CRUCIFORM PANELS

STATE OF FLORIDA DEPARTMENT OF TRANSPORTATION				
RETAINING WALL SYSTEM REINFORCED EARTH COMPANY REINFORCED EARTH WALL				
Designed By	Names	Dates	Approved By <i>W. V. [Signature]</i>	
Drawn By			Revision	Sheet No. Index No.
Checked By			00	2 of 14 5015

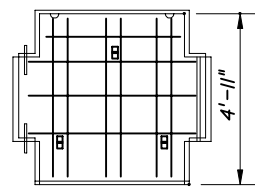

A-3-R5

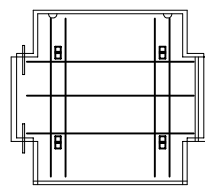

A-4-R4

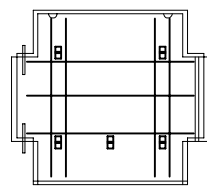

A-5-R4

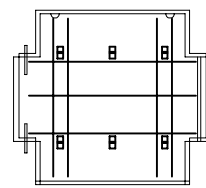

A-6-R4

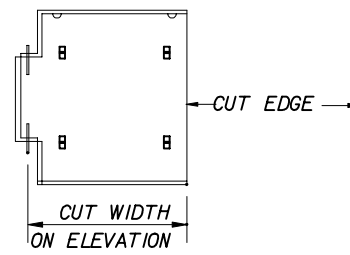

AL-4-R4

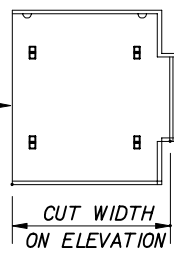

AR-4-R4

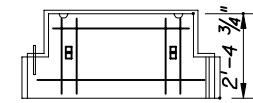

B-2-R4

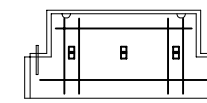

B-3-R4

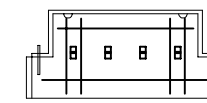

B-4-R4



C-2-R4

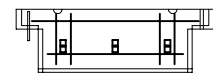

C-3-R4

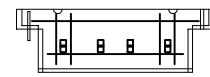

C-4-R4

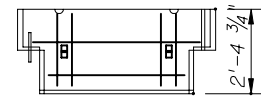

D-2-R4

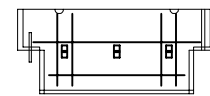

D-3-R4

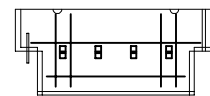

D-4-R4

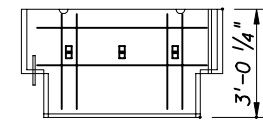

E-3-R4

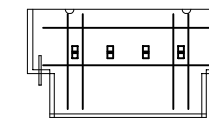

E-4-R4

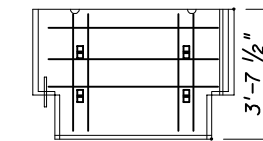

F-4-R4

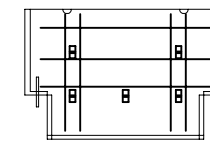

F-5-R4

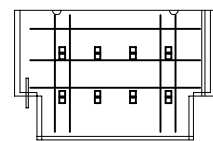

F-8-R4

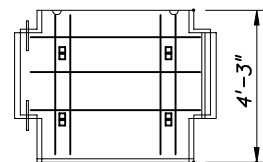

G-4-R4

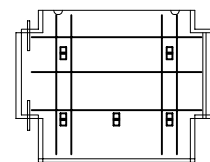

G-5-R4

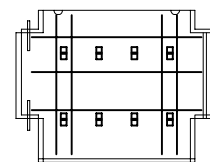

G-8-R4

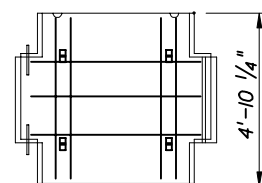

H-4-R4

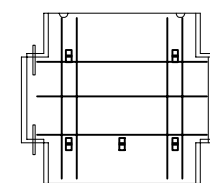

H-5-R4

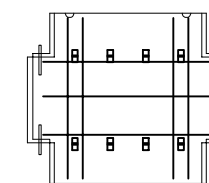

H-8-R4

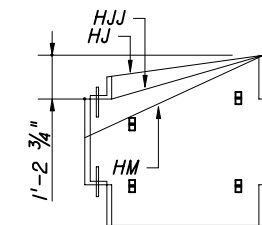

HJ-4-R4

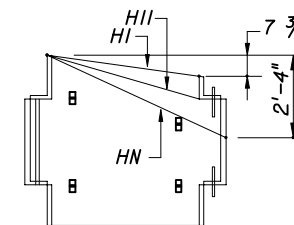

HI-4-R4

SLOPED TOP PANELS
"H" PANEL USED FOR ILLUSTRATION ONLY.

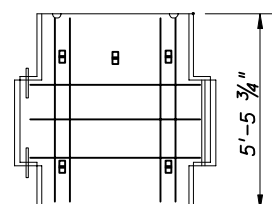

K-5-R4

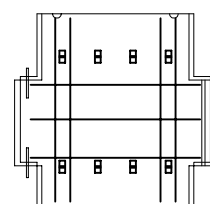

K-8-R4

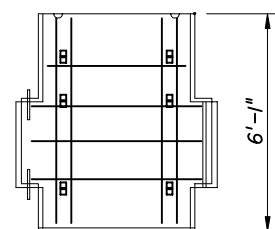

L-6-R4

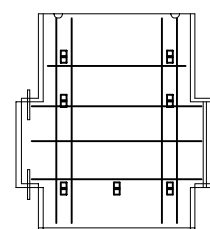

L-7-R4

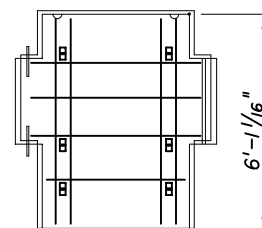

P-6-R4

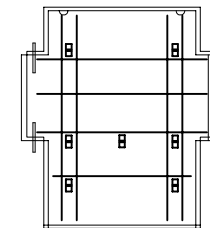

P-7-R4

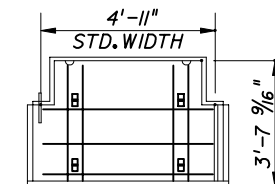

Q-4-R4

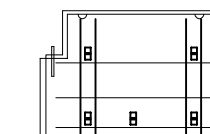

Q-5-R4

ALL PANELS ARE SHOWN BACK FACE VIEW

⊠ TIE STRIP LOCATION

R4 VERTICAL BARS ARE #3 AS SHOWN
R5 HORIZONTAL BARS ARE #4 AS SHOWN

R6 VERTICAL BARS ARE 6-#3
R7 HORIZONTAL BARS ARE 4-#4

R7 VERTICAL BARS ARE 6-#4
HORIZONTAL BARS ARE 4-#6

SEE PANEL TPE "A" WITH R4 REINFORCEMENT
ON SHEET TITLED "PANEL DETAILS" FOR TYPICAL
REINFORCEMENT SPACING

THIS SYSTEM SHALL BE USED IN SLIGHTLY OR
MODERATELY AGGRESSIVE ENVIRONMENTS ONLY
CRUCIFORM PANELS

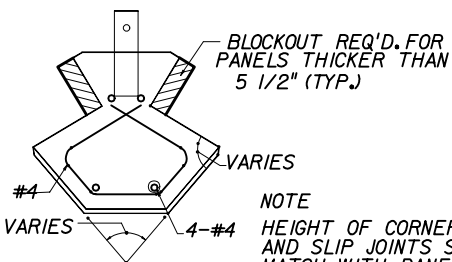

CORNER ELEMENT
SIZE VARIES WITH ANGLES

NOTE
HEIGHT OF CORNER ELEMENTS
AND SLIP JOINTS SHOULD
MATCH WITH PANEL HEIGHT.

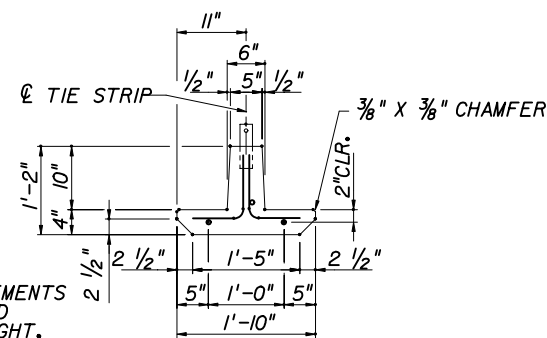

SLIP JOINT

STATE OF FLORIDA DEPARTMENT OF TRANSPORTATION

RETAINING WALL SYSTEM
REINFORCED EARTH COMPANY
REINFORCED EARTH WALL

Names	Dates	Approved By		
Designed By		 State Structures Design Engineer	Revision	Sheet No.
Drawn By			00	3 of 14
Checked By				Index No. 5015

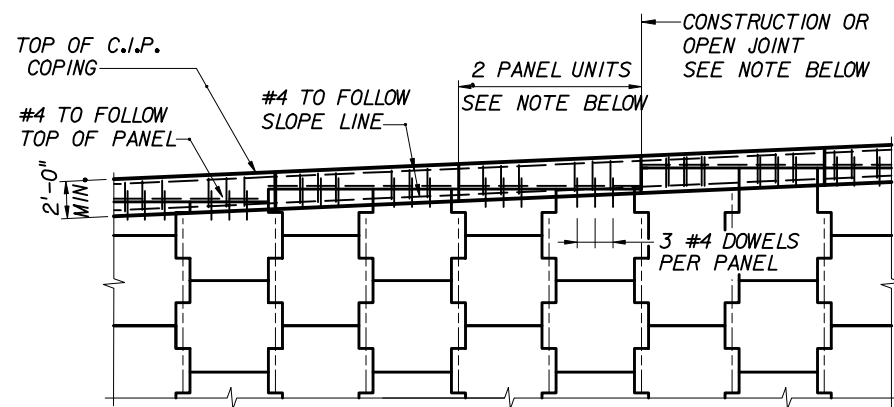

C.I.P. COPING - PARTIAL ELEVATION

NOTE:

1/2-INCH OPEN JOINTS IN COPING SHALL BE AT 6 PANEL INTERVALS AND COINCIDE APPROXIMATELY WITH ϕ OF ALIGNMENT PINS. REINFORCING STEEL SHALL BE STOPPED 2" SHORT OF EITHER SIDE OF THE JOINTS. CONSTRUCTION JOINTS IN BETWEEN THE OPEN JOINTS SHALL BE PROVIDED AT 2 PANELS INTERVALS.

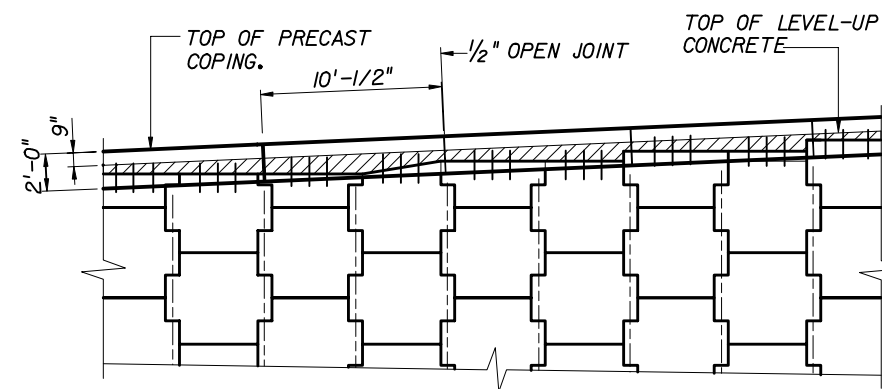

PRECAST COPING PARTIAL ELEVATION

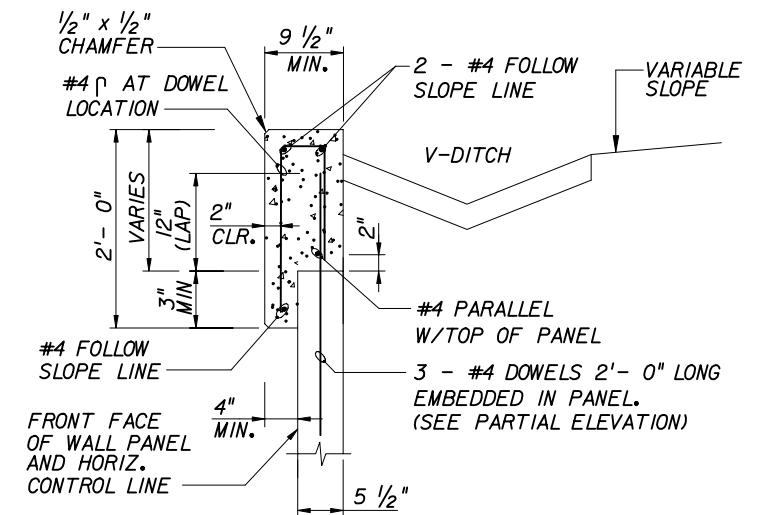

C.I.P. CONC. COPING W/DITCH

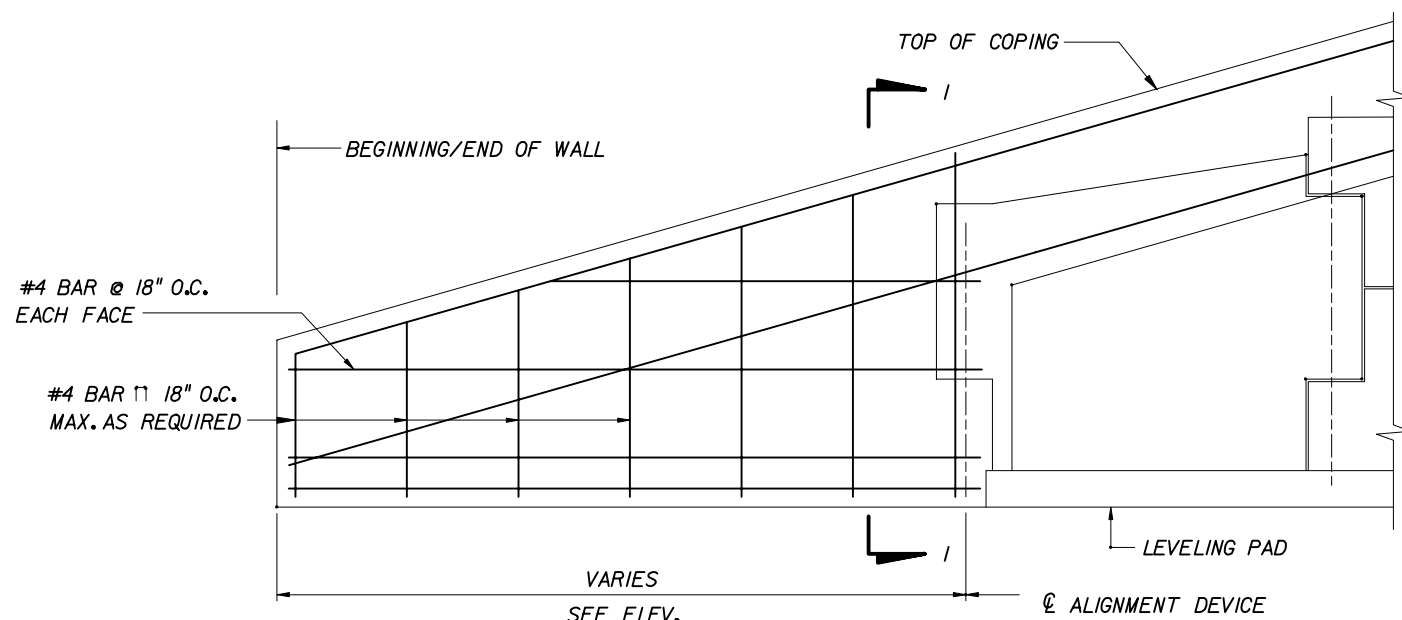

COPING ENCLOSURE DETAIL

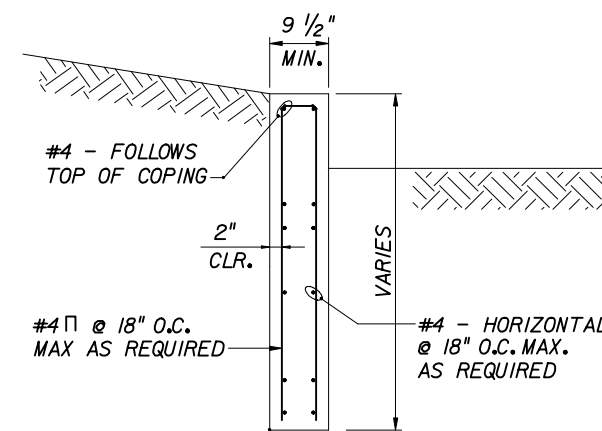

SECTION A-A

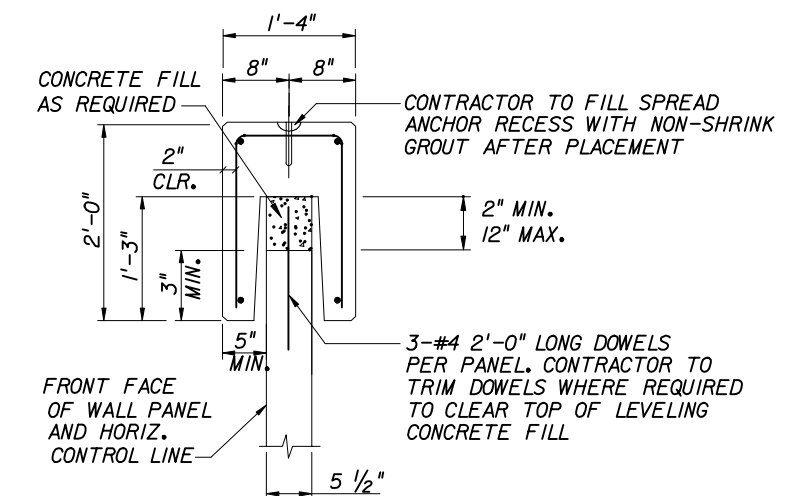

PRECAST COPING SECTION

NOTE:

STANDARD COPING UNIT IS 10' LONG WITH SQUARE ENDS.

THIS SYSTEM SHALL BE USED IN SLIGHTLY OR MODERATELY AGGRESSIVE ENVIRONMENTS ONLY
CRUCIFORM AND SQUARE PANELS

STATE OF FLORIDA DEPARTMENT OF TRANSPORTATION				
RETAINING WALL SYSTEM REINFORCED EARTH COMPANY REINFORCED EARTH WALL				
Names	Dates	Approved By <i>W. J. [Signature]</i>		
Designed By		State Structures Design Engineer		
Drawn By		Revision	Sheet No.	Index No.
Checked By		00	4 of 14	5015

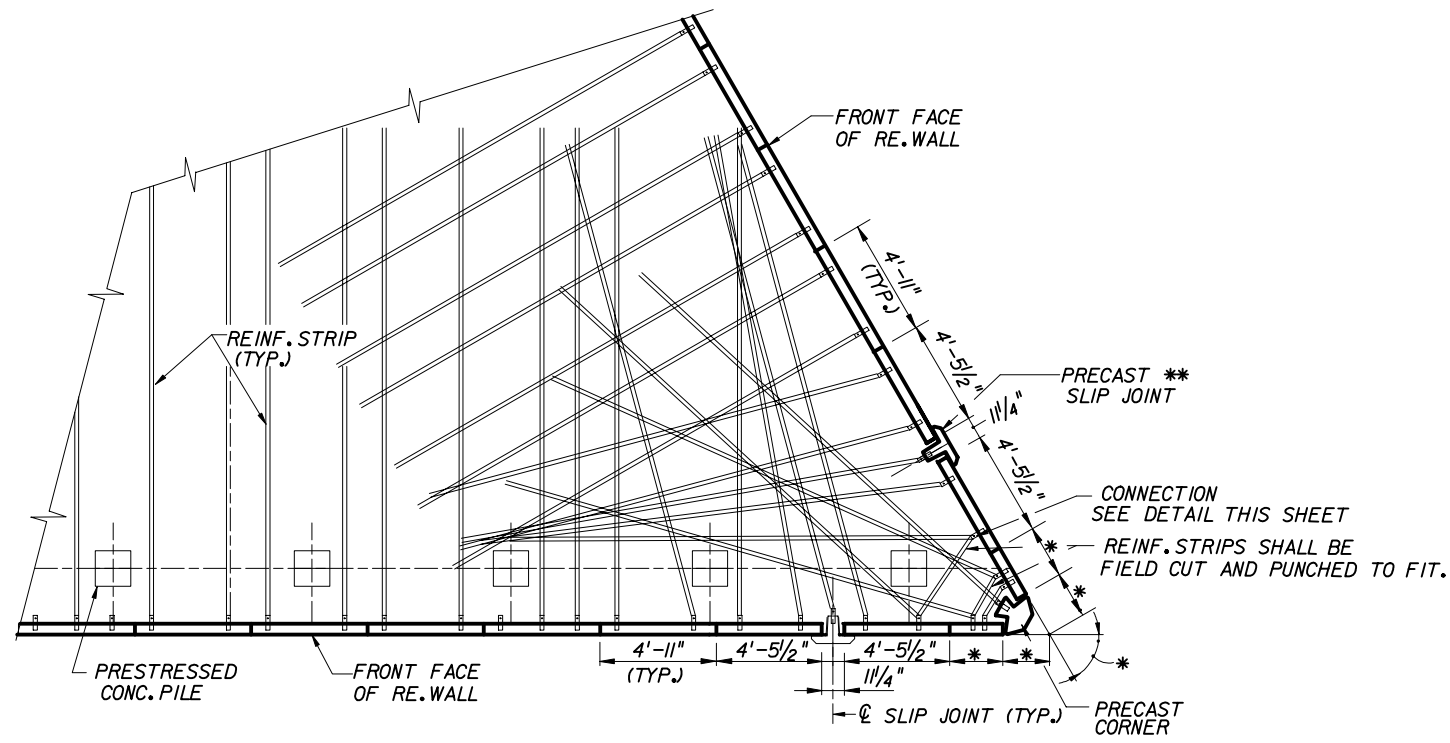

EXAMPLE ACUTE CORNER - SKEWED STRIPS UNDER PILE CAP

NOTE:

- * - DIMENSION OR ANGLE VARIES, SEE WALL ELEVATION
- ** - SLIP JOINTS ARE NOT REQUIRED FOR SQUARE PANELS

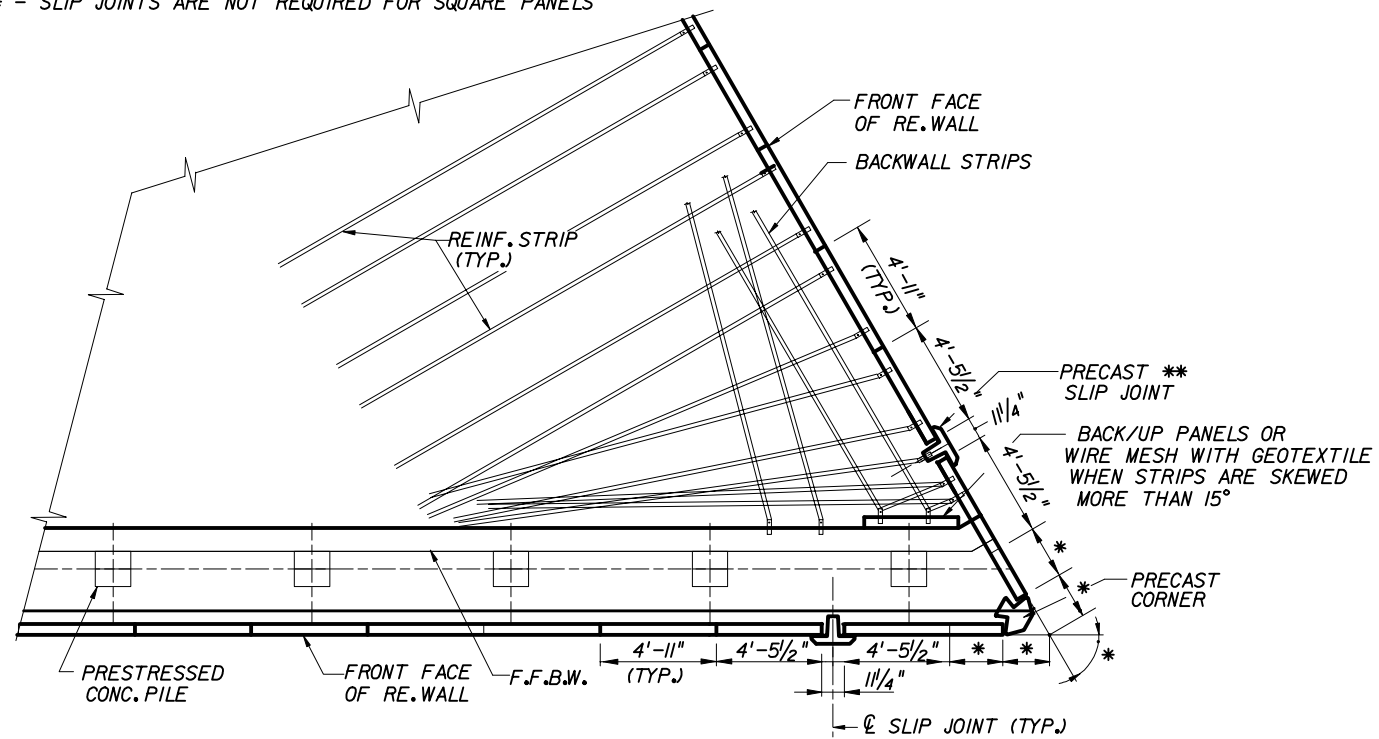

EXAMPLE ACUTE CORNER - SKEWED STRIPS AT ABUTMENT LEVEL

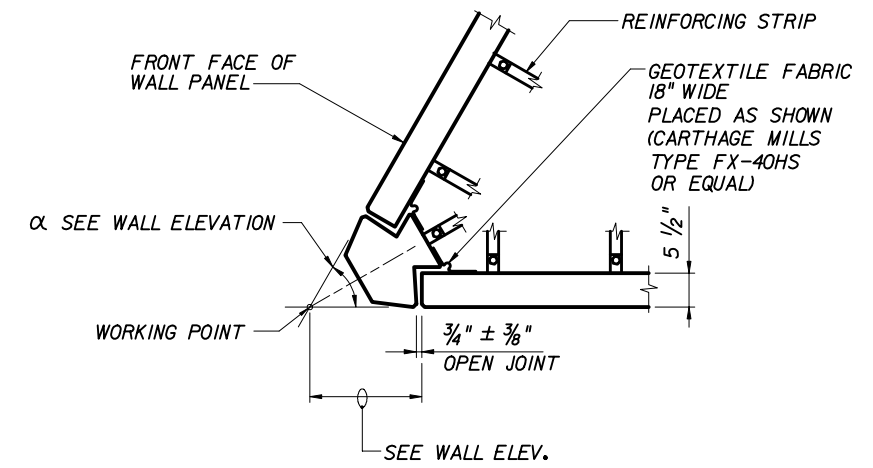

ACUTE CORNER ELEMENT DETAIL

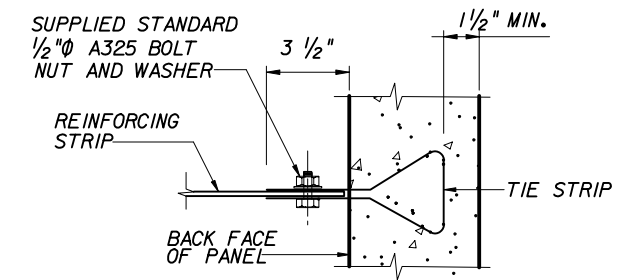

CONNECTION DETAIL

THIS SYSTEM SHALL BE USED IN SLIGHTLY OR MODERATELY AGGRESSIVE ENVIRONMENTS ONLY
CRUCIFORM AND SQUARE PANELS

STATE OF FLORIDA DEPARTMENT OF TRANSPORTATION				
RETAINING WALL SYSTEM REINFORCED EARTH COMPANY REINFORCED EARTH WALL				
Designed By	Names	Dates	Approved By <i>W. J. [Signature]</i>	
Drawn By			Revision	Sheet No. Index No.
Checked By			00	5 of 14 5015

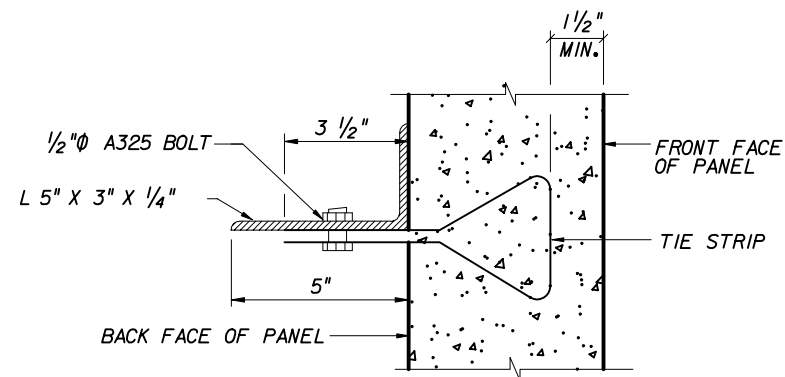

1 CONNECTION DETAIL
ANGLE BOLTED TO TIE STRIP

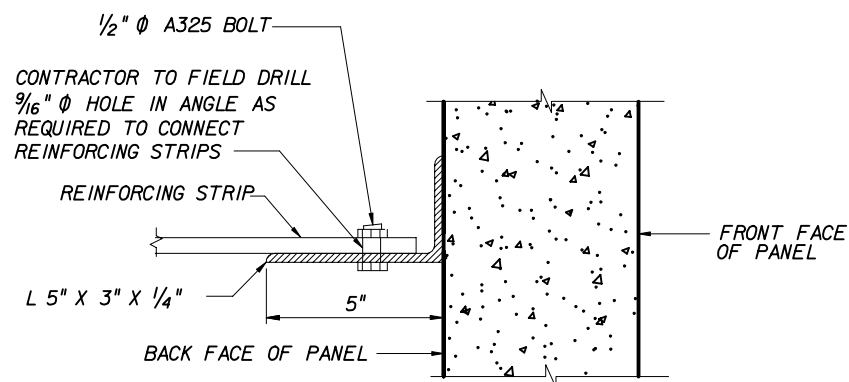

2 CONNECTION DETAIL
SHIFTED REINF. STRIP BOLTED TO ANGLE

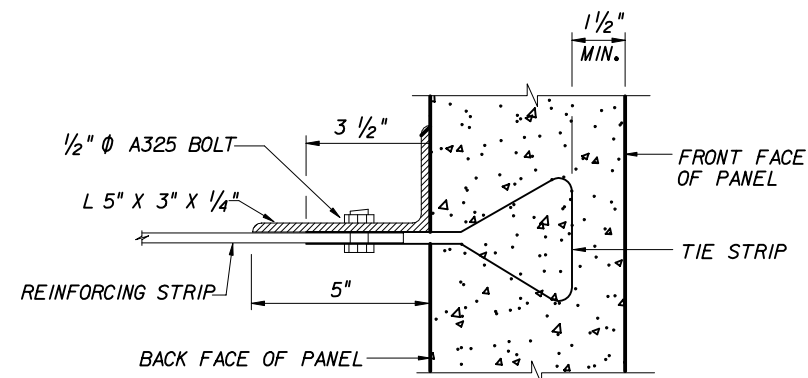

3 CONNECTION DETAIL
ANGLE BOLTED TO TIE STRIP WITH REINF. STRIP

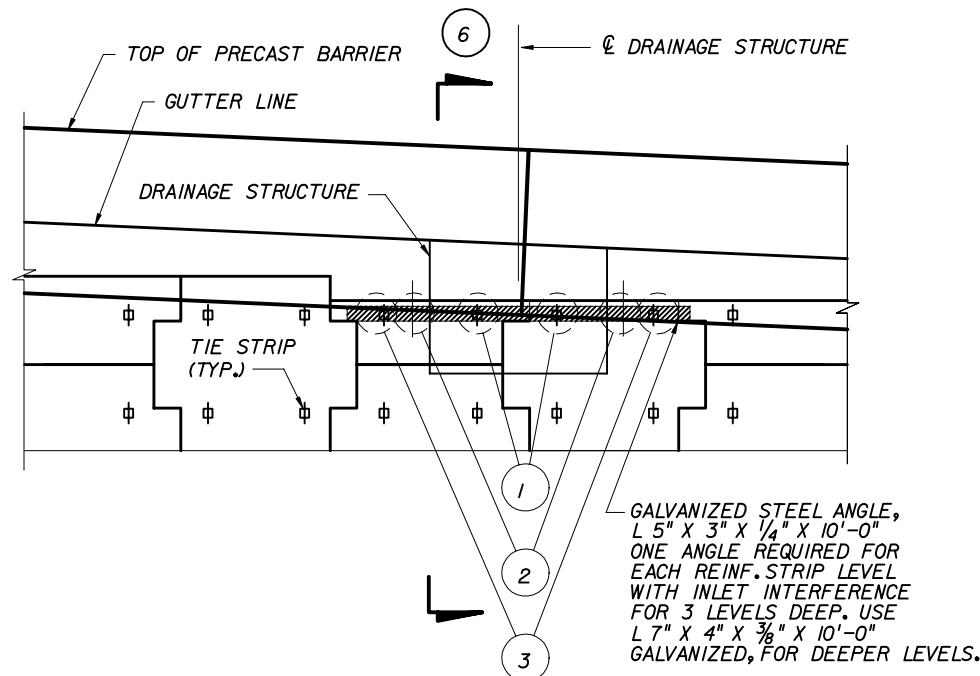

4 PARTIAL ELEVATION

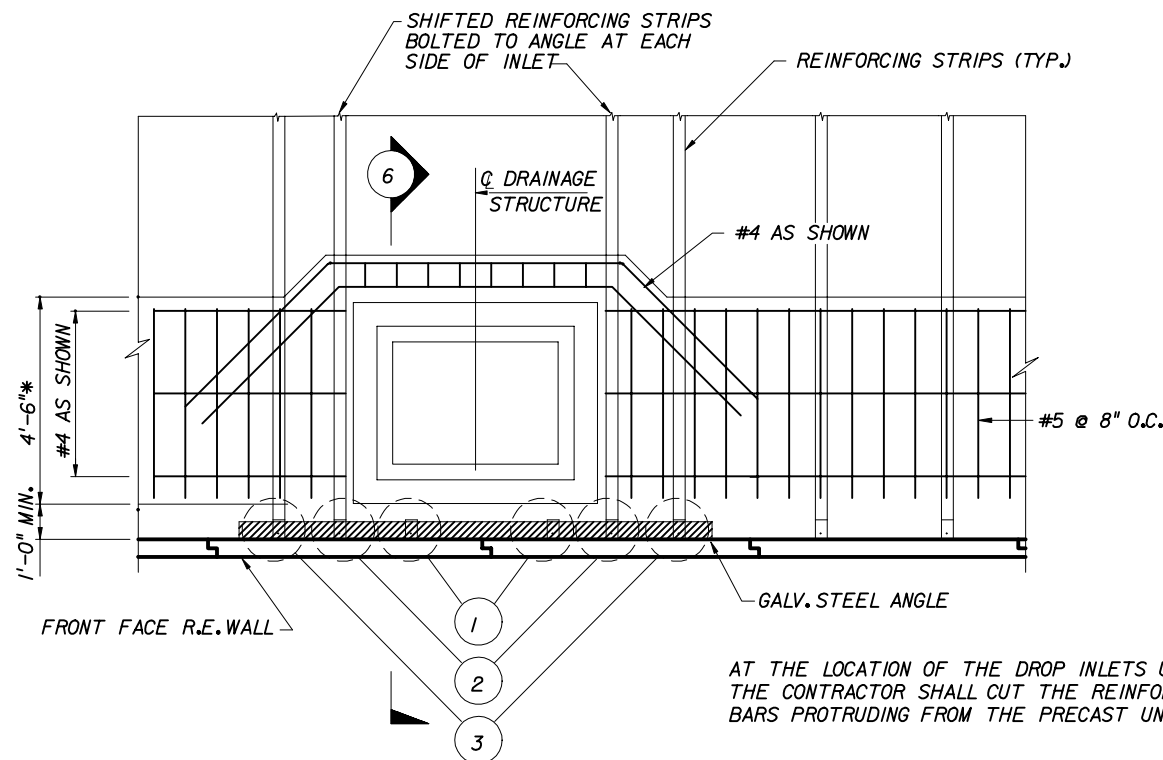

5 PARTIAL PLAN

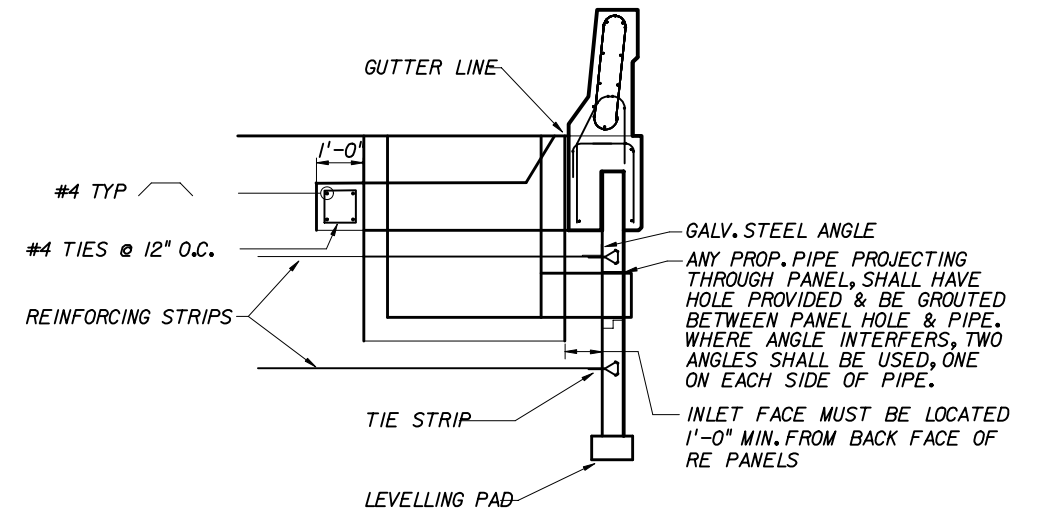

6 SECTION AT INLET

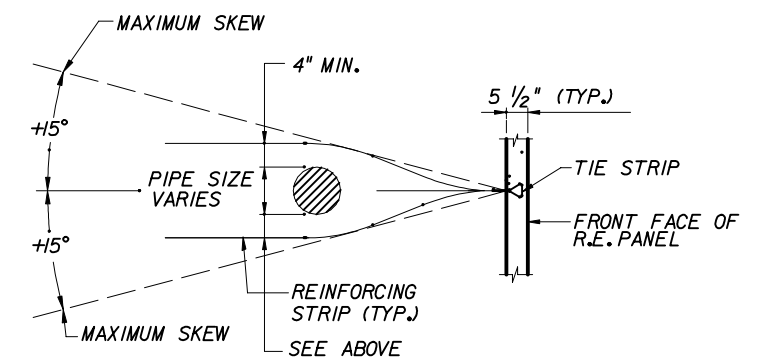

NOTE: BEND TO BE AS GRADUAL AS POSSIBLE.

7 TYPICAL STRIP BENDING DETAIL AT
ANY PROPOSED & EXISTING PIPES

AT THE LOCATION OF THE DROP INLETS UNITS,
THE CONTRACTOR SHALL CUT THE REINFORCEMENT
BARS PROTRUDING FROM THE PRECAST UNIT.

THIS SYSTEM SHALL BE USED IN SLIGHTLY OR
MODERATELY AGGRESSIVE ENVIRONMENTS ONLY
CRUCIFORM AND SQUARE PANELS

STATE OF FLORIDA DEPARTMENT OF TRANSPORTATION

RETAINING WALL SYSTEM
REINFORCED EARTH COMPANY
REINFORCED EARTH WALL

Names	Dates	Approved By
Designed By		W. V. [Signature]
Drawn By		State Structures Design Engineer
Checked By		Revision Sheet No. Index No.
		00 6 of 14 5015

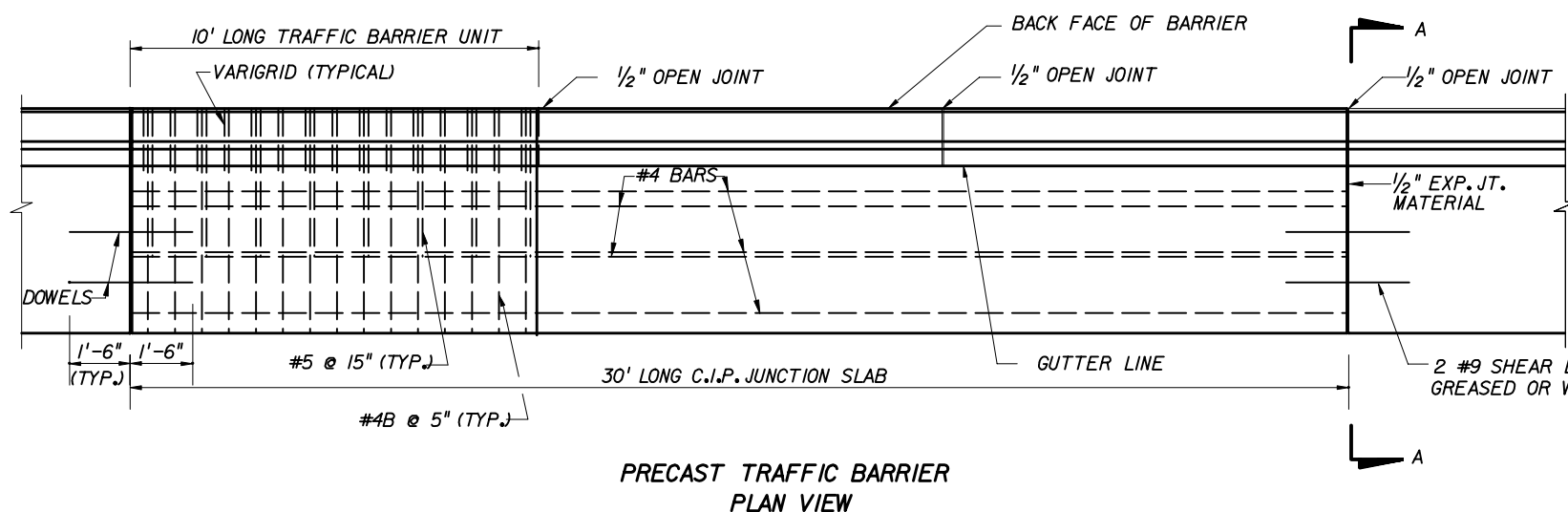

PRECAST TRAFFIC BARRIER
PLAN VIEW

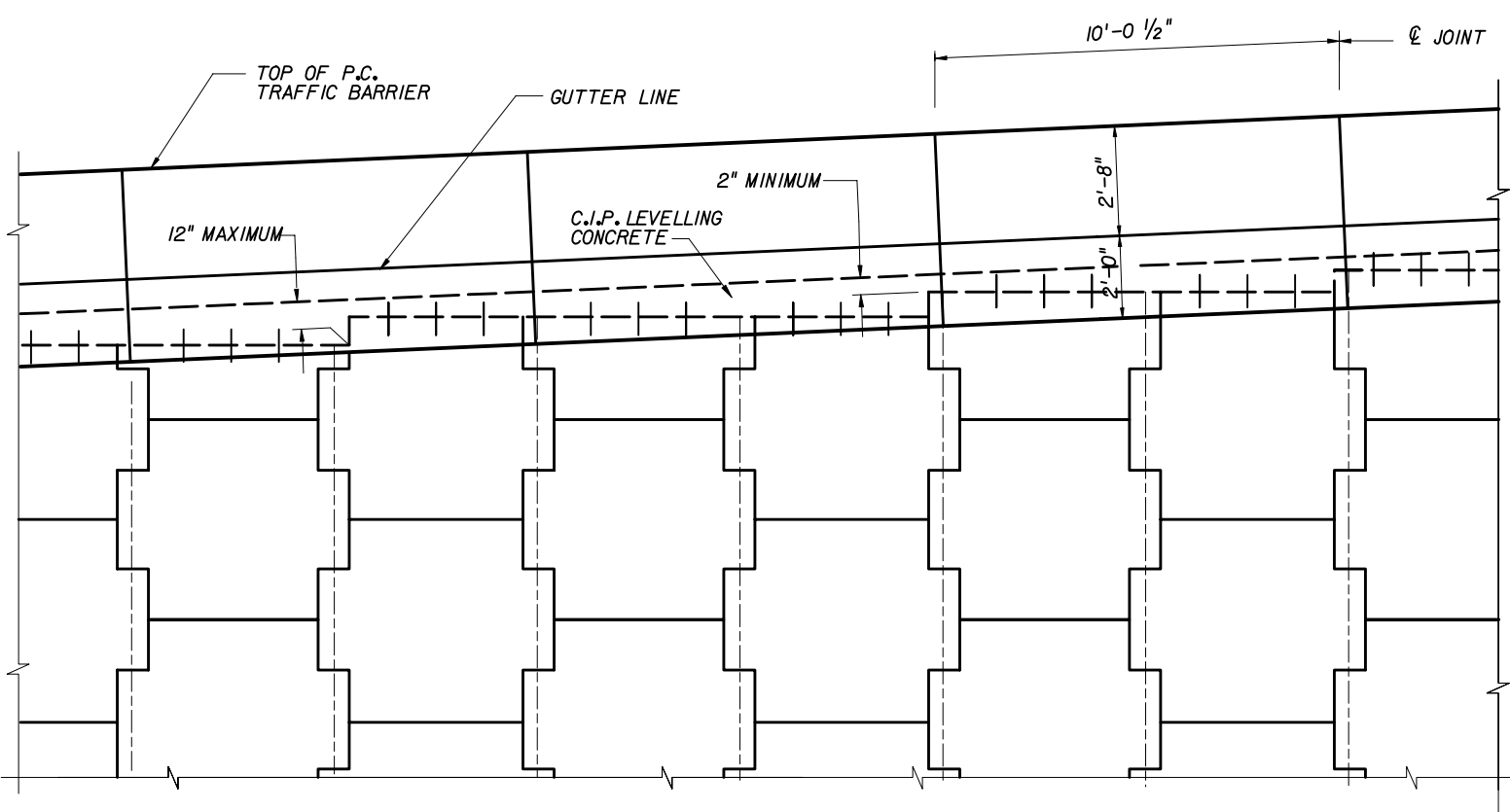

PRECAST TRAFFIC BARRIER
PARTIAL ELEVATION

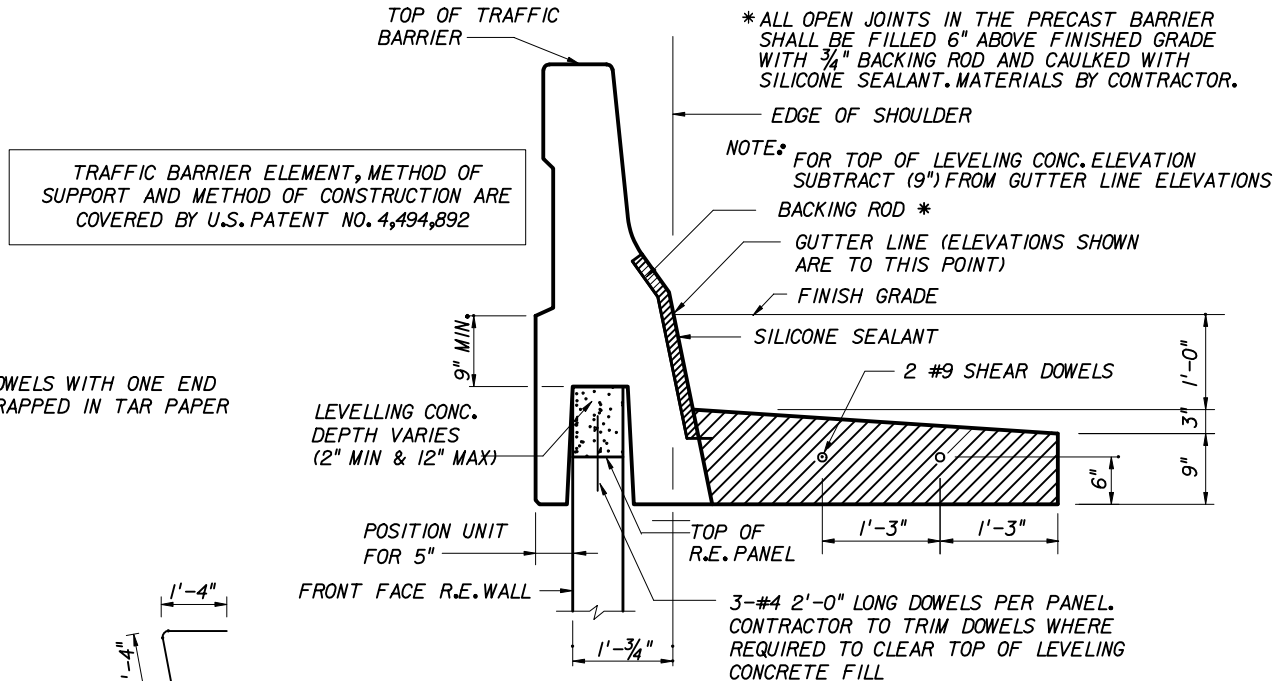

SECTION A-A AT APPROACH SLAB

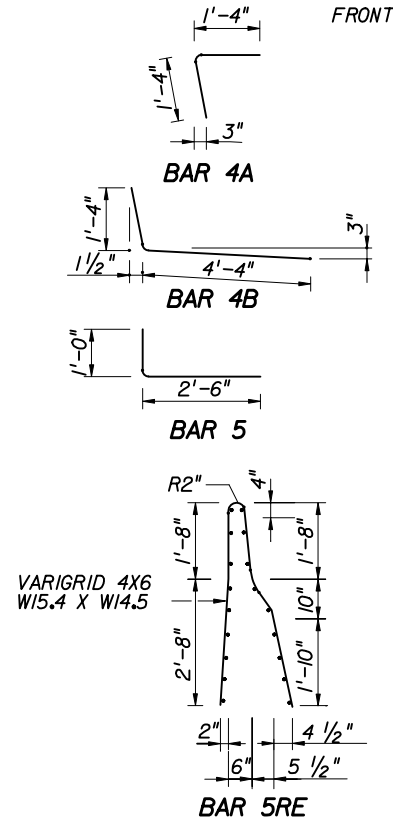

MARK	QUANTITY	REMARKS
5	8	3'-6" LONG
A	VARIGRID	WI4.5 @ 6" O.C.
B	VARIGRID	WI5.4 @ 4" O.C.
4A	8	2'-8" LONG
4B	24	5'-8" LONG

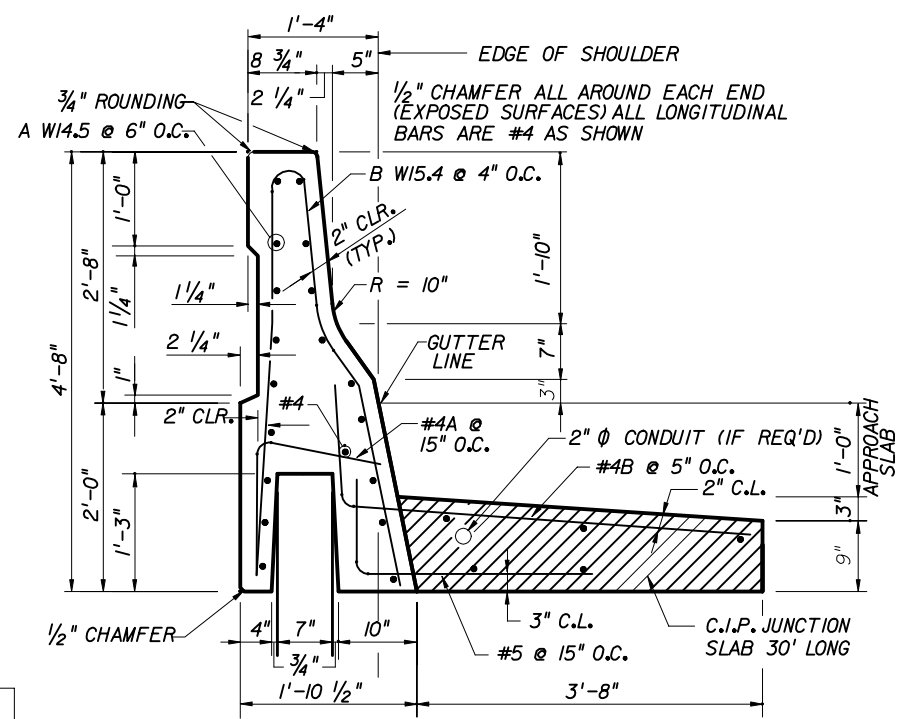

TRAFFIC BARRIER REINFORCEMENT

THIS SYSTEM SHALL BE USED IN SLIGHTLY OR MODERATELY AGGRESSIVE ENVIRONMENTS ONLY
CRUCIFORM AND SQUARE PANELS

STATE OF FLORIDA DEPARTMENT OF TRANSPORTATION

RETAINING WALL SYSTEM
REINFORCED EARTH COMPANY
REINFORCED EARTH WALL

Names	Dates	Approved By
Designed By		W. J. [Signature]
Drawn By		State Structures Design Engineer
Checked By		Revision Sheet No. Index No.
	00	7 of 14 5015