

METAL OR PLASTIC CAPS FOR DOWEL BARS

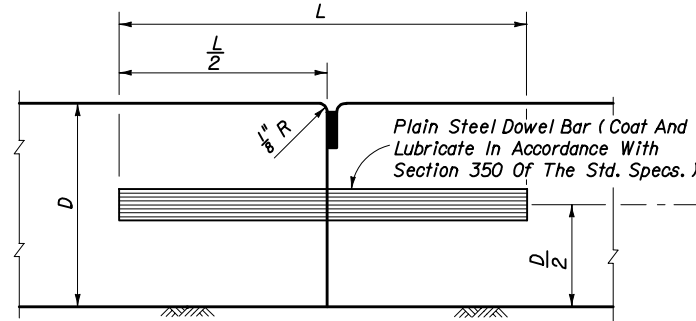
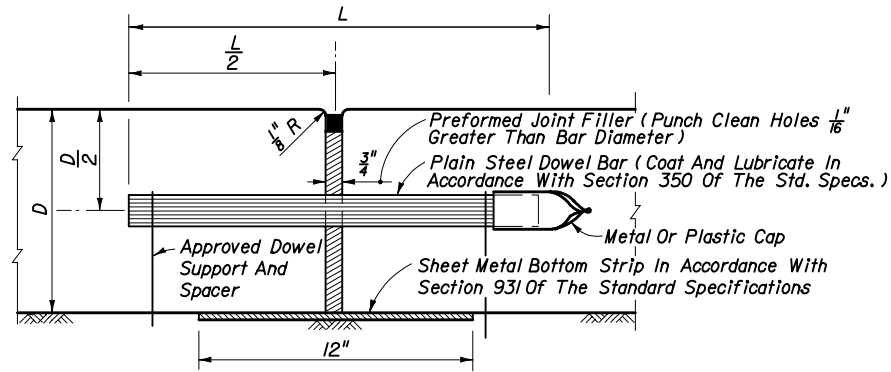

BUTT CONSTRUCTION JOINT TO BE USED AT DISCONTINUANCES OF WORK

Note: Expansion joints to be placed on approaches to bridges, at street intersections and other locations indicated in detail plans.

TRANSVERSE EXPANSION JOINT

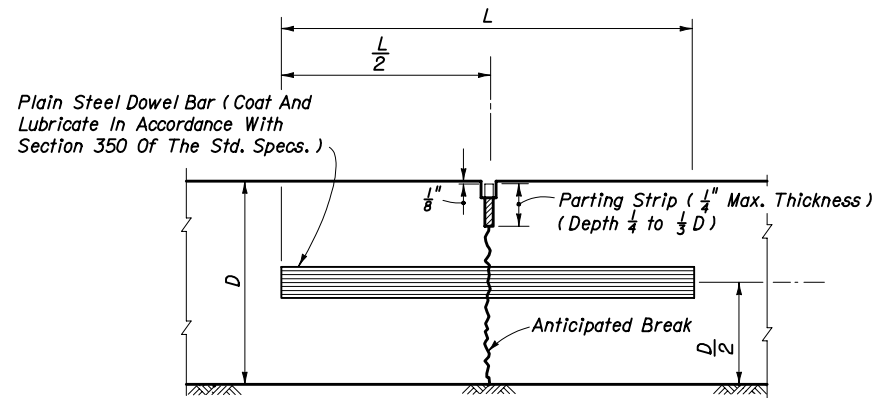

TRANSVERSE CONTRACTION JOINT, VIBRO CAST METHOD

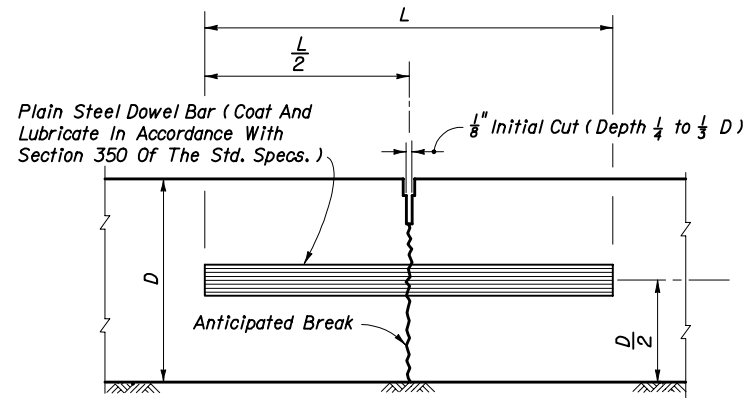

TRANSVERSE CONTRACTION JOINT, SAWED METHOD

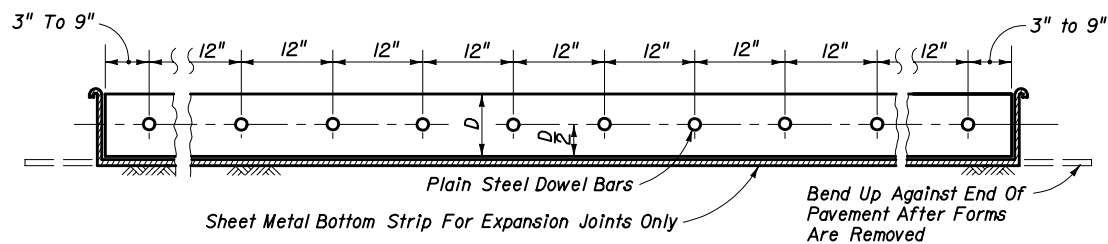

DOWEL BAR LAYOUT

DOWELS (LENGTH 18")	
Pavement Thickness "D"	Diameter
6" - 6 1/2"	3/4"
7" - 8 1/2"	1"
9" - 10 1/2"	1 1/4"
≥ 11"	1 1/2"

TRANSVERSE JOINTS ARE TO BE SPACED AT A MAXIMUM OF 15'. DOWELS ARE REQUIRED AT ALL TRANSVERSE JOINTS UNLESS OTHERWISE NOTED IN PLANS.

TRANSVERSE JOINTS

Pavement Thickness "D"	MAXIMUM TIE BAR SPACING			
	Distance To Closest Free Edge			
	12'	24'	24'	24'
	#4 Bars Length 25"	#5 Bars Length 30"	#4 Bars Length 25"	#5 Bars Length 30"
6"	48"	48"	26"	41"
7"	45"	48"	22"	35"
8"	39"	48"	19"	31"
9"	35"	48"	17"	27"
10"	31"	48"	15"	24"
11"	29"	45"	14"	22"
12"	26"	41"	13"	20"
13"	24"	38"	12"	19"
14"	22"	35"	11"	17"
15"	21"	33"	10"	16"

Tie bars are deformed #4 or #5 reinforcing steel bars meeting the requirements of Section 931 of the Standard Specifications.

When the distance to the closest free edge exceeds 24', provide a standard load transfer tied joint with #4 bars at 24" spacing. This joint can then be considered a free edge for determination of tie bar spacing on other joints.

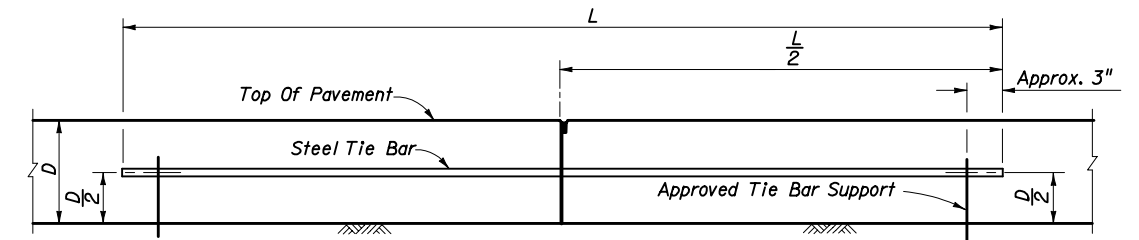

Note: Tie bar spacing shall not exceed 24" at these joints.
LONGITUDINAL BUTT CONSTRUCTION JOINT

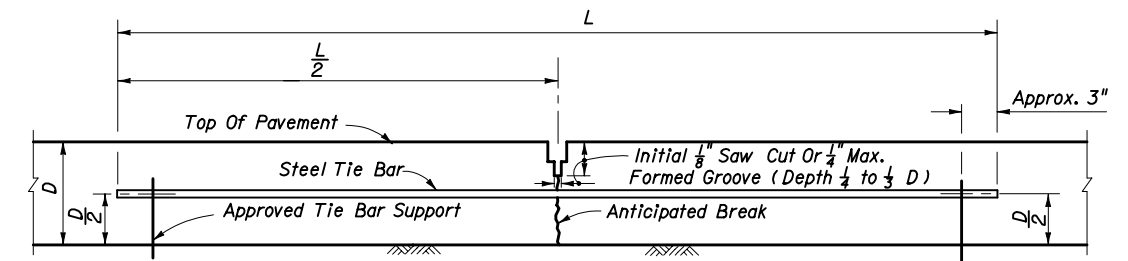

Note: Slabs poured simultaneously. Tie bars may be inserted in the plastic concrete by means approved by the Engineer.

LONGITUDINAL LANE-TIE JOINT

LONGITUDINAL JOINTS

Note: For joint seal dimensions see Sheet 2.

STATE OF FLORIDA DEPARTMENT OF TRANSPORTATION				
CONCRETE PAVEMENT JOINTS				
Names	Dates	Approved By		
Designed By		Bryan Distel		
Drawn By	HW 08/57	State Pavement Design Engineer		
Checked By	HBC 08/57	Revision	Sheet No.	Index No.
		04	1 of 4	305

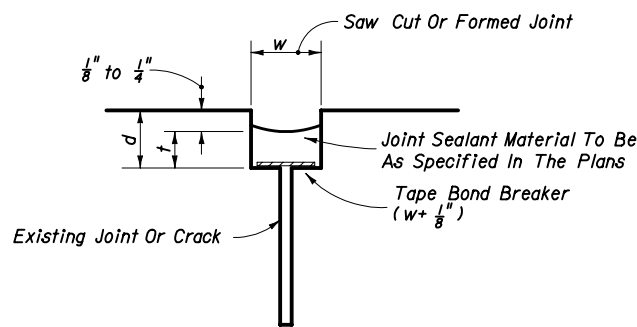

Note: Dimension w will be shown in the plans or established by the Engineer based on field conditions. Dimension d will be constructed so that the shape factor $\frac{d}{w}$ has a maximum value of 2.0 and a minimum value of 1.0.

FOR REHABILITATION PROJECTS
TAPE BOND BREAKER

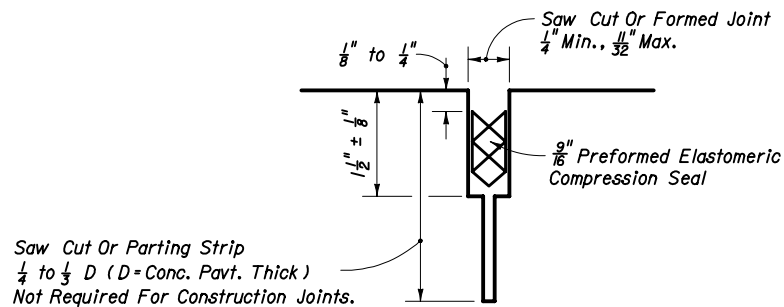

FOR NEW PROJECTS
PREFORMED ELASTOMERIC COMPRESSION SEAL

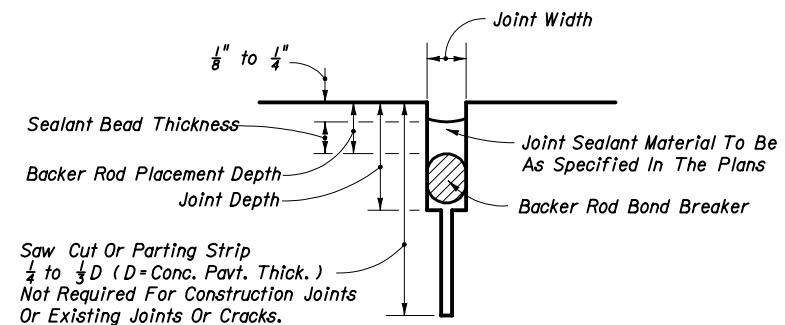

FOR NEW AND REHABILITATION PROJECTS
BACKER ROD BOND BREAKER

BACKER ROD BOND BREAKER (CONCRETE-CONCRETE JOINTS)				
JOINT DIMENSIONS (INCHES)				
JOINT WIDTH	SEALANT BEAD THICKNESS	BACKER ROD DIAMETER	MINIMUM JOINT DEPTH	BACKER ROD PLACEMENT DEPTH
1/4	1/4	3/8	1	1/2
3/8	1/4	1/2	1 1/4	1/2
1/2	1/4	5/8	1 1/4	1/2
5/8	5/16	3/4	1 1/2	9/16
3/4	3/8	1	1 3/4	5/8
7/8	7/16	1 1/8	1 3/4	11/16
1	1/2	1 1/4	2	3/4
> 1	1/2	1 1/2 +	2 +	3/4

Unless otherwise indicated on the plans the joint width for new construction will be 1/4" for construction joints, 3/8" for all other joints.

For rehabilitation projects the joint width will be shown on the plans or established by the Engineer based on field conditions.

CONCRETE-CONCRETE JOINTS

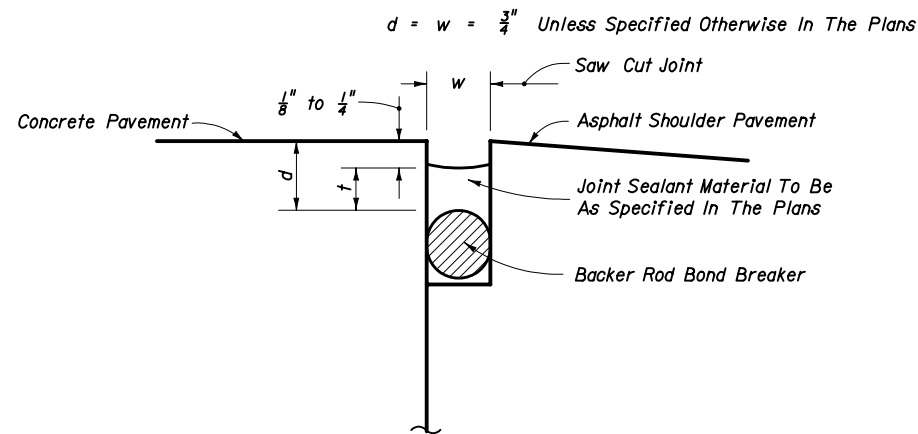

BACKER ROD BOND BREAKER

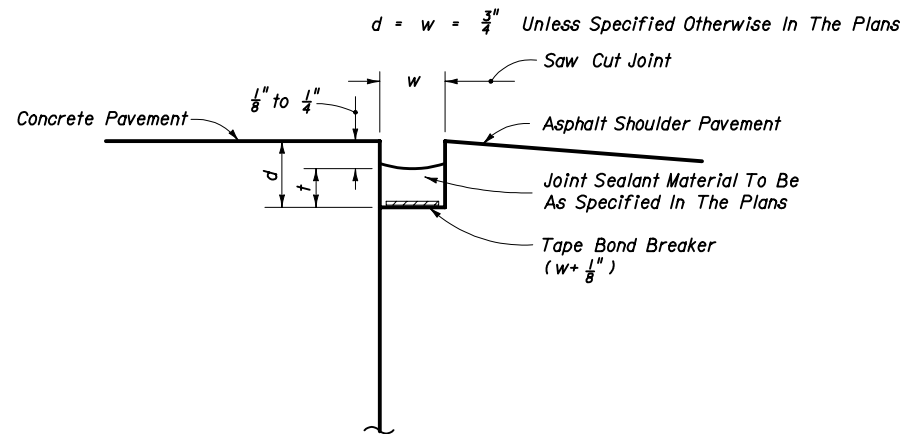

TAPE BOND BREAKER

FOR NEW AND REHABILITATION PROJECTS;
EITHER TAPE OR BACKER ROD BOND BREAKER REQUIRED;
SHOULDER MUST BE REPAIRED IF PROPER JOINT SHAPE
CAN NOT BE ATTAINED

CONCRETE-ASPHALT SHOULDER JOINTS

JOINT SEAL DIMENSIONS

STATE OF FLORIDA DEPARTMENT OF TRANSPORTATION				
CONCRETE PAVEMENT JOINTS				
Designed By	Names	Dates	Approved By	
Drawn By	HSD	05/86	Bryan Distal State Pavement Design Engineer	
Checked By	JVG	05/86	Revision	Sheet No.
			00	2 of 4
				Index No. 305

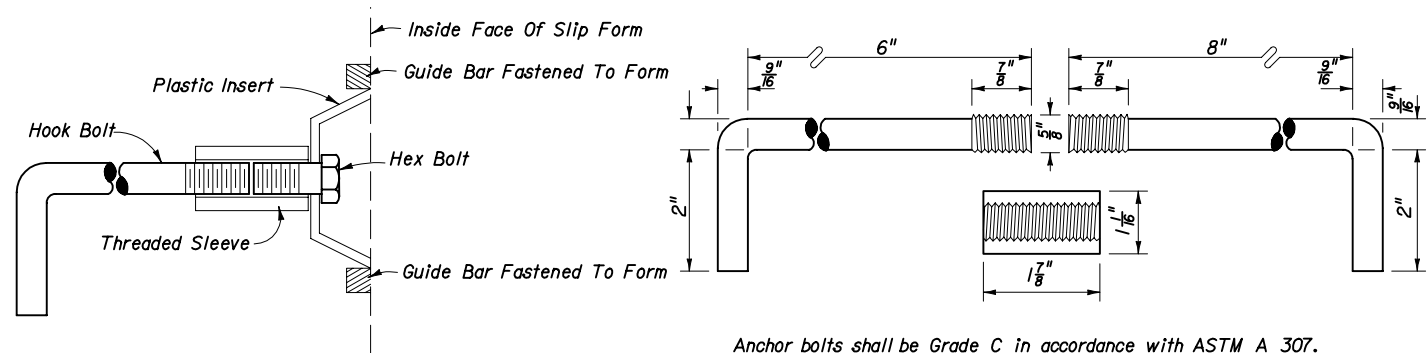

NOTE: After the concrete has set to the extent that the keyway will retain its shape, the hex bolt and plastic insert shall be removed. The remaining portion of the hook bolt assembly shall be installed immediately prior to placing of concrete in the adjacent lane.

Anchor bolts shall be Grade C in accordance with ASTM A 307. Threaded sleeves shall develop the full strength of the bolt and meet the material and thread requirements of ASTM A 563.

**ALTERNATE KEYWAY AND HOOK BOLT
STEEL HOOK BOLT ASSEMBLY**

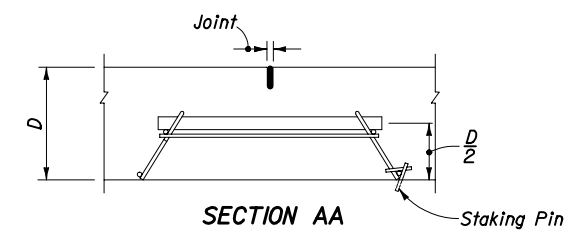
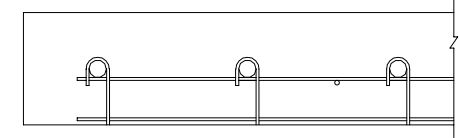
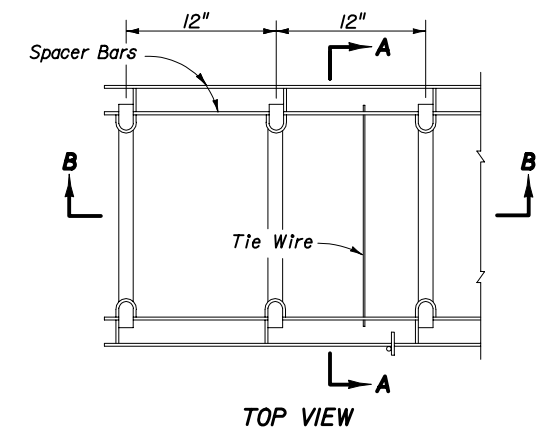

CONTRACTION ASSEMBLY

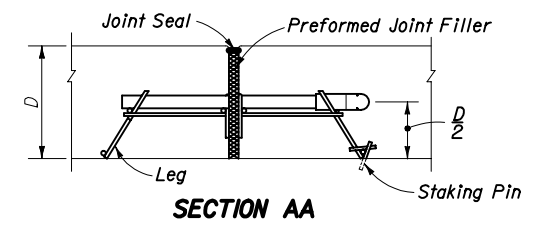
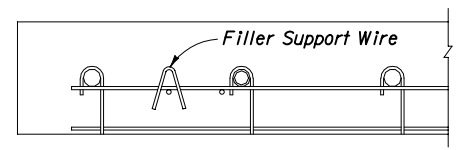
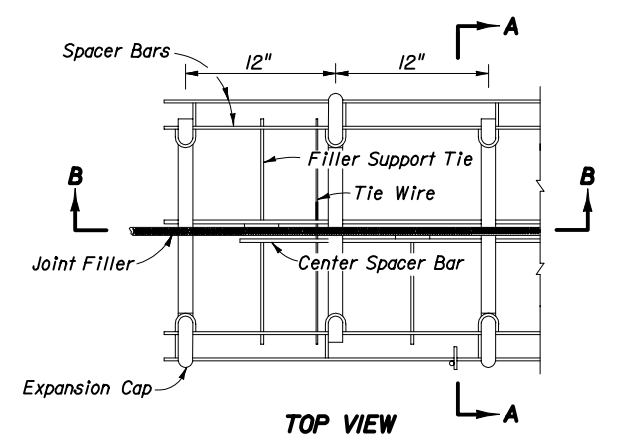

EXPANSION ASSEMBLY

Note:
Proprietary contraction and expansion assemblies may be used. Products shall be introduced to the State Construction Office in accordance with section (C) of the Product Evaluation Procedure.

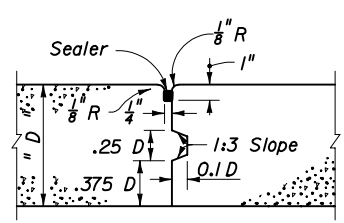

KEYED JOINT

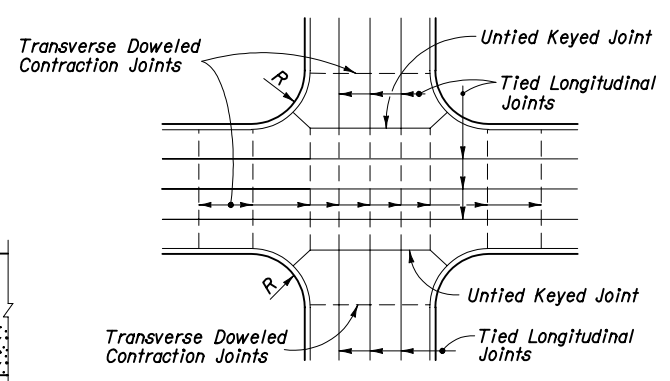

JOINT LAYOUT AT THRU INTERSECTION

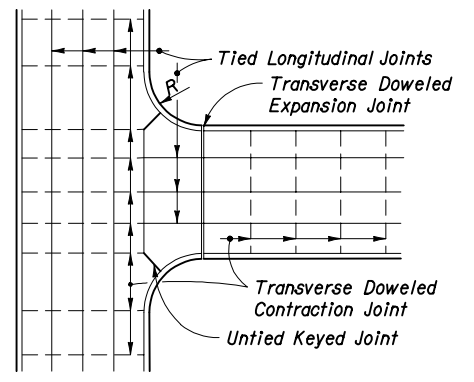

JOINT LAYOUT AT 'T' INTERSECTIONS

NOTES

1. Longitudinal joints will not be required for single lane pavement 14' or less in width. For entrance and exit ramp joint details, see Sheet 4 of 4.
2. Arrangement of longitudinal joints are to be as directed by the Engineer.
3. All manholes, meter boxes and other projections into the pavement shall be boxed-in with 1/2" preformed expansion joint material.

JOINT ARRANGEMENT

STATE OF FLORIDA DEPARTMENT OF TRANSPORTATION

CONCRETE PAVEMENT JOINTS

Names	Dates	Approved By <i>Bruce Distel</i>		
Designed By	HMD 07/97	State Pavement Design Engineer		
Drawn By	HSD 07/94	Revision	Sheet No.	Index No.
Checked By	HMD 07/97	00	3 of 4	305

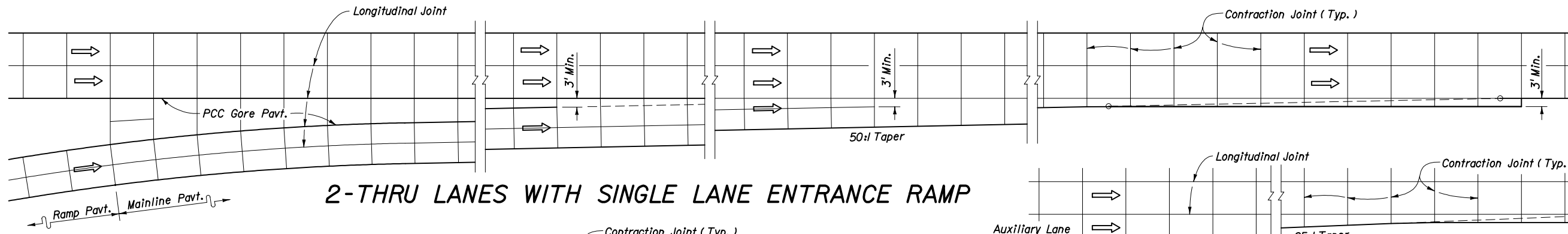

2-THRU LANES WITH SINGLE LANE ENTRANCE RAMP

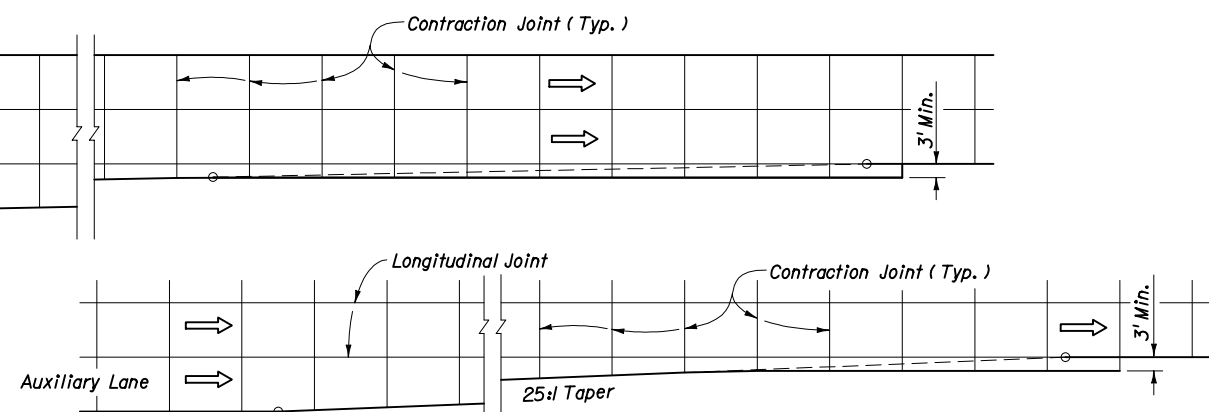

ENTRANCE TAPER WITH AUXILIARY LANE

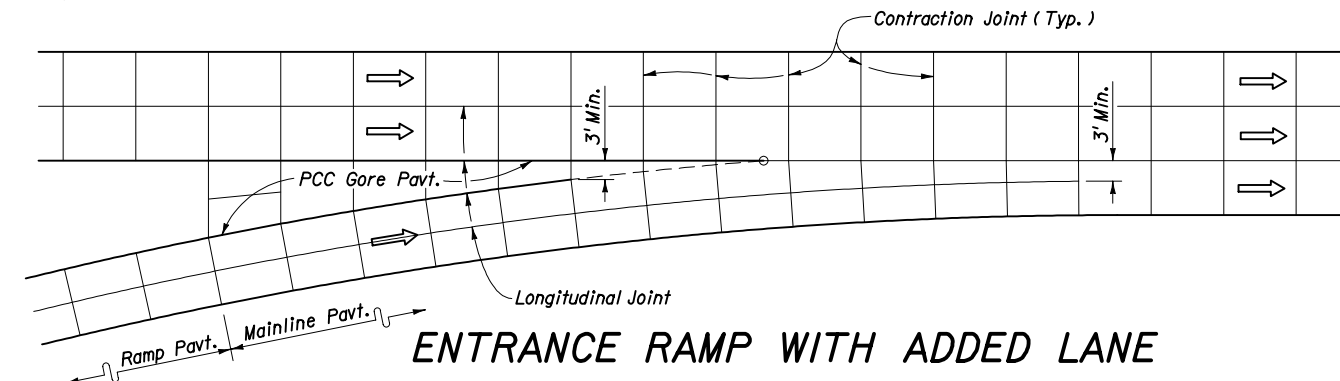

ENTRANCE RAMP WITH ADDED LANE

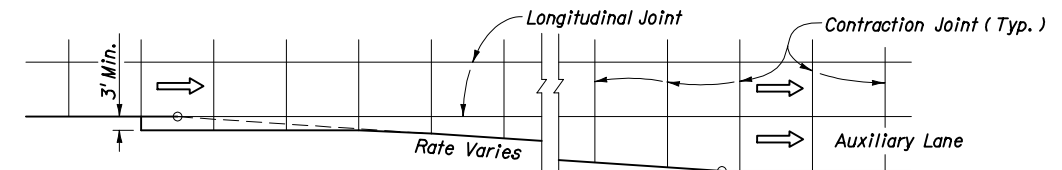

EXIT TAPER WITH AUXILIARY LANE

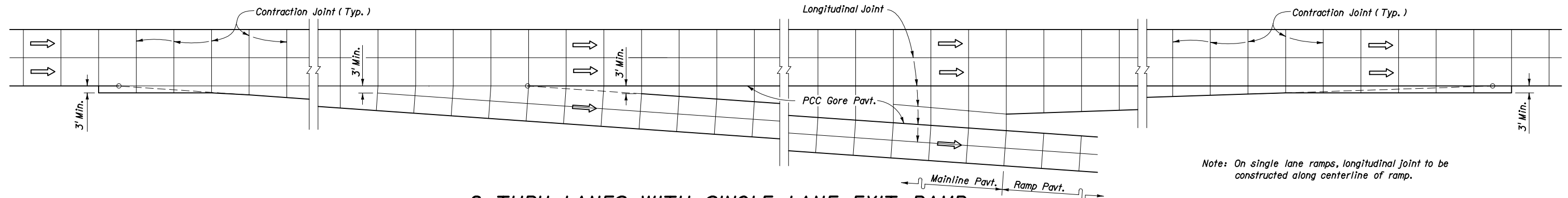

2-THRU LANES WITH SINGLE LANE EXIT RAMP

Note: On single lane ramps, longitudinal joint to be constructed along centerline of ramp.

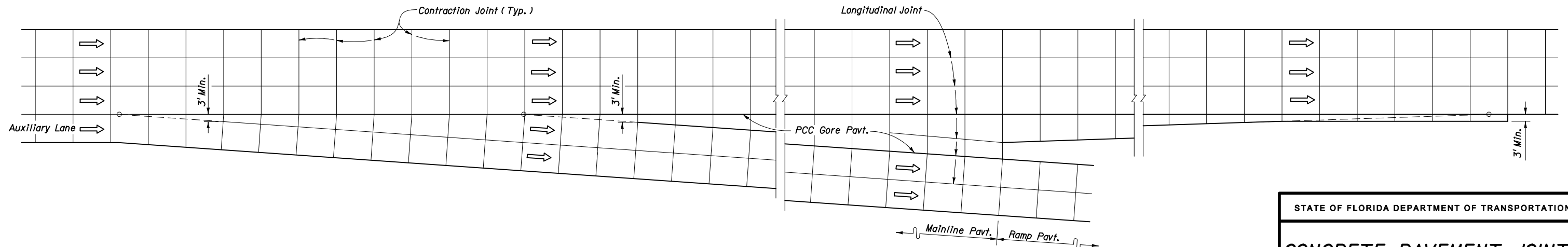

3-THRU LANES WITH AUXILIARY LANE AND 2-LANE EXIT RAMP

JOINT LAYOUT AT ENTRANCE AND EXIT RAMP TERMINALS

STATE OF FLORIDA DEPARTMENT OF TRANSPORTATION				
CONCRETE PAVEMENT JOINTS				
Designed By	Names	Dates	Approved By	
Drawn By	HKH/STD	11/91	B. M. Dittus State Pavement Design Engineer	
Checked By	WNL	11/91	Revision	Sheet No. Index No.
			00	4 of 4 305