

JUNCTION OF ROADWAY DITCH * AND LATERAL DITCH

* Soil cement or misc. asphalt will not be permitted for this type of construction

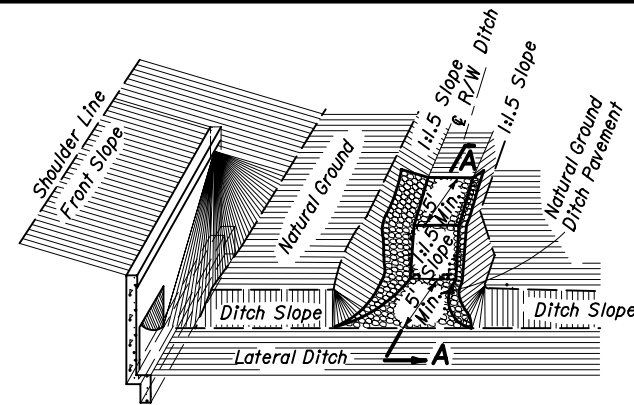

JUNCTION OF R/W DITCH * AND LATERAL DITCH

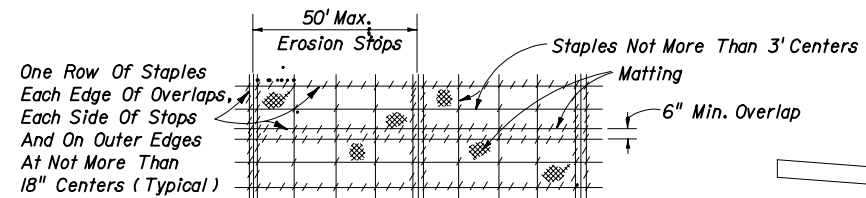

PLAN

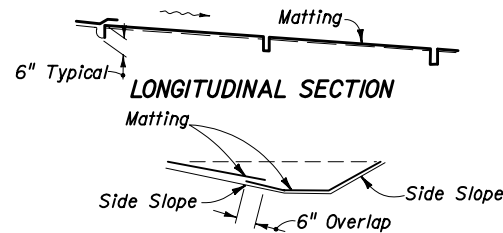

LONGITUDINAL SECTION

SECTION MATTING FOR DITCH

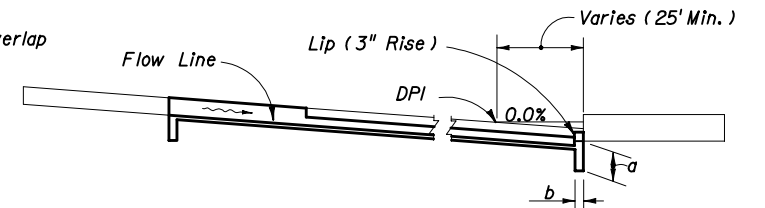

SECTION EE

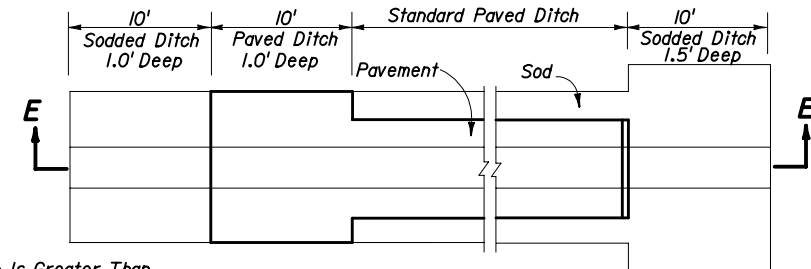

PLAN

PAVED DITCH END TREATMENT

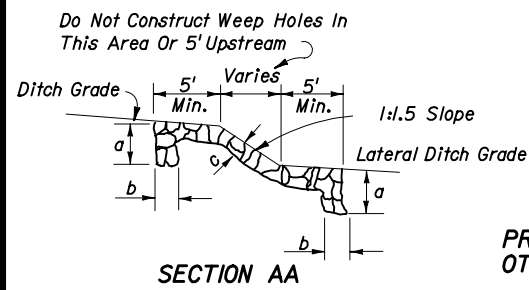

SECTION AA

PROFILE OF DITCH PAV'T AT LOCATIONS OTHER THAN JUNCTION WITH LATERAL DITCH

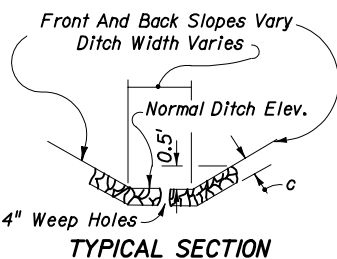

TYPICAL SECTION

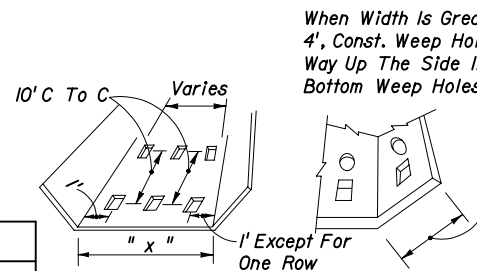

When "X" = 1' To 4' Const. 1 Row (Centered)
 "X" = 5' To 7' Const. 2 Rows
 "X" = 8' To 12' Const. 3 Rows
 "X" = 13' To 17' Const. 4 Rows
 "X" = 18' To 22' Const. 5 Rows

GENERAL NOTES

1. Type of ditch pavement shall be as shown on plans.
2. In concrete ditch pavement, contraction joints are to be spaced at 25' maximum intervals, or as directed by the Engineer. Contraction joints may be either formed (construction joint) or tooled. No open joints will be permitted.
3. Lip at end of ditch pavement shall normally be located downstream of DPI or on flatter grades where there is a decrease in ditch velocity.
4. Toewalls are to be used with all ditch paving. A toewall is not required adjacent to drainage structures.
5. When directed by the Engineer, weep hole spacing may be reduced to 5' minimum.
6. For junction of R/W ditch spillway and lateral ditch, sides of paving to be 1' high minimum.
7. For ditch pavements requiring filter fabric the fabric shall be placed directly beneath the pavement for the entire length and width of the pavement. When weep holes with aggregate are used the filter fabric shall be placed below the aggregate to form a mat continuous with or overlapping the pavement fabric. (See Index No. 199 for fabric type and application).
8. Ditch pavement requiring reinforcement shall be detailed in the plan.
9. Cost of plastic filter fabric to be included in the contract unit price for ditch pavement.

Notes: All weep holes to be 3" x 4" rectangle or 4" or 5" dia. circular hole. 1/2 cu. ft. (12" x 12" x 6") of No. 6 aggregate to be placed under each hole. 1 sq. ft. of galvanized wire mesh (1/4" openings) shall be placed between the aggregate and the concrete. Cost of holes, aggregate and wire mesh to be included in the cost of ditch pavement.

WEEP HOLE ARRANGEMENT

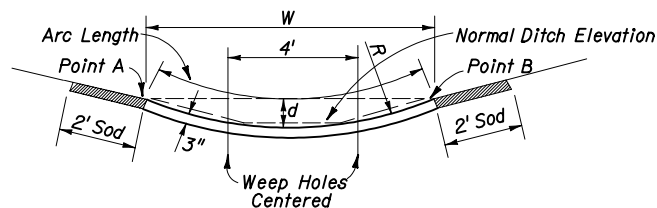

TO REPLACE:

	W	d	R	No. Of Rows Of Weep Holes	Arc Length
6' Median Swale 1:6 Front Slopes; 1:4 Back Slope	6'	.24'	19'	0	6.0
5' B.W. Ditch	10'	.67'	19'	2	10.1
4' B.W. Ditch	9'	.54'	19'	2	9.1
1:4 Front Slopes & Back Slope	9'	.74'	14'	2	9.2
5' B.W. Ditch	8'	.58'	14'	1 (in center)	8.1

ALTERNATE DITCH PAVEMENT

For use only where side slopes are 1:4 or flatter. Point "A" and "B" are to be the same elevation and should be used to locate the paved section.

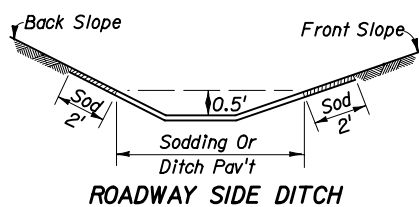

ROADWAY SIDE DITCH

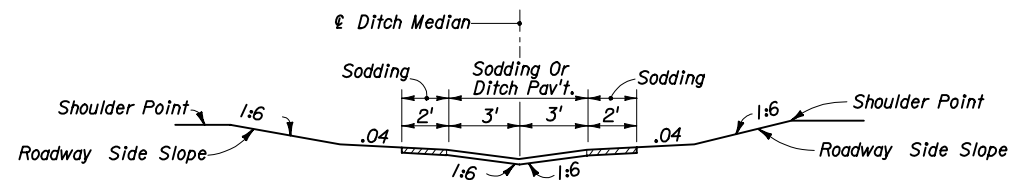

SWALED MEDIAN (No Weep Holes)

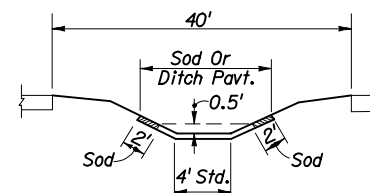

40' MEDIAN

STATE OF FLORIDA DEPARTMENT OF TRANSPORTATION

DITCH PAVEMENT & SODDING

Designed By	Names	Dates	Approved By
Drawn By			<i>[Signature]</i> State Drainage Engineer
Checked By			Revision
			Sheet No.
		00	1 of 2
			Index No.
			281

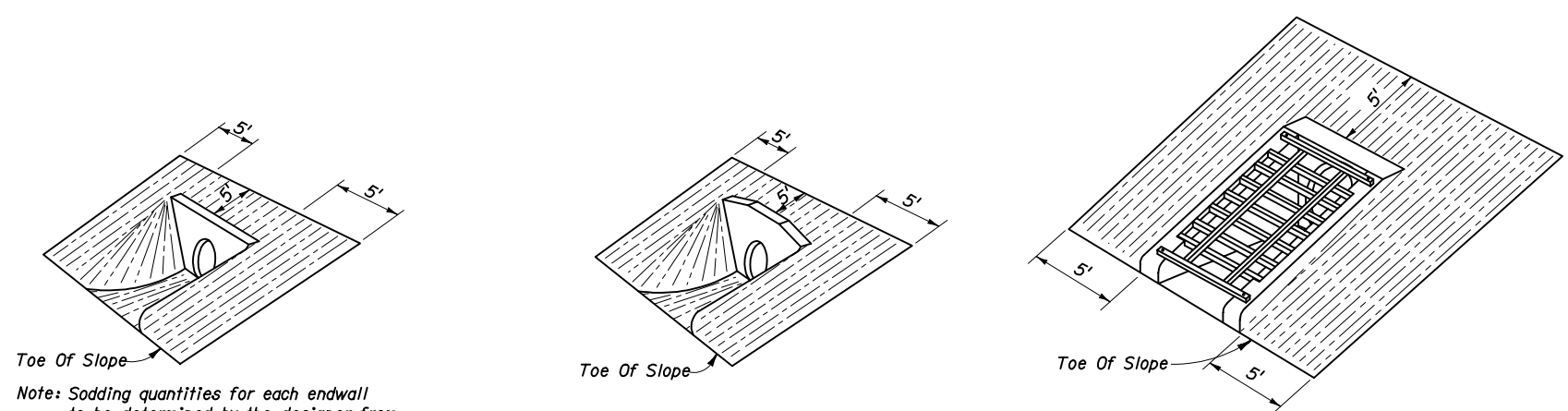

Note: Sodding quantities for each endwall to be determined by the designer from this detail.

(EXCEPT INDEX NO. 250)
STRAIGHT ENDWALL
INDEX NO. 250

STRAIGHT ENDWALL
INDEX NO. 250

U - TYPE ENDWALL
INDEX NO. 261

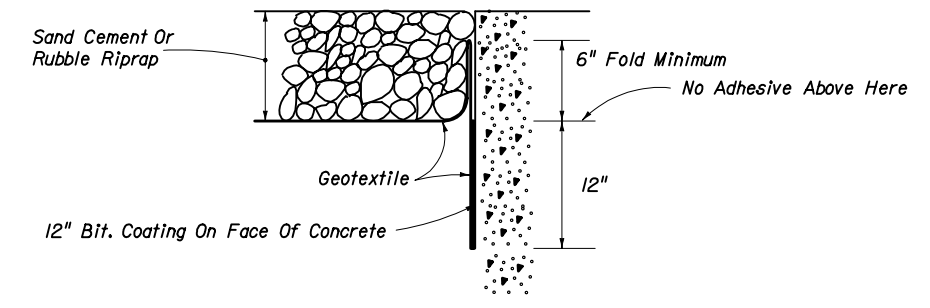

BONDED OPTION

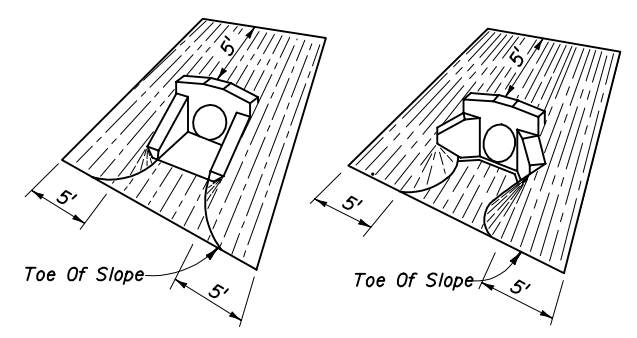

U - TYPE WINGS

45° WINGS

WINGED ENDWALLS
INDEX NO. 266

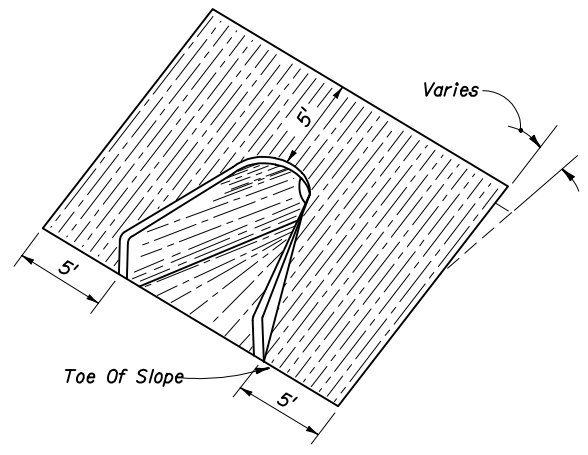

FLARED END SECTION
INDEX NO. 270

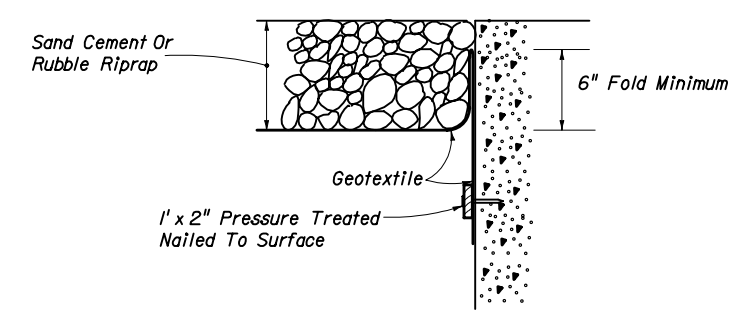

NAILED OPTION

Note: Either option may be used unless otherwise called for in the plans.

GEOTEXTILE PLACEMENT AT CONCRETE STRUCTURE

SODDING QUANTITIES (S. Y.)																						
PIPE SIZE	INDEX NO. 250												INDEX NO. 261				INDEX NO. 266				INDEX NO. 270	
	SLOPE												SLOPE				SLOPE					ALL SLOPES
	1: 2			1: 3			1: 4			1: 6			1: 2		1: 3		1: 4		1: 6			
	PIPES												PIPES				PIPES					
1	2	3	1	2	3	1	2	3	1	2	3	1	1	1	1	1	1	1	1	1		
12"																14	15	18	22	10		
15"	19	21	24	22	26	29	26	30	33	34	38	43	13 (15)	16	17	23	15	17	20	25	11	
18"	21	24	27	25	29	33	30	34	38	39	44	50	14 (16)	17	19	25	16	18	22	28	11	
21"																					12	
24"	26	30	34	32	37	42	38	44	50	50	58	66	15 (17)	19	21	28	19	22	26	34	14	
27"																					15	
30"	31	37	42	39	46	53	46	55	63	62	74	85	17 (18)	21	24	32	21	25	30	40	16	
36"	37	44	52	46	56	65	56	67	79	76	91	107					24	29	35	47	18	
42"	43	53	62	55	67	79	67	82	96	91	111	132					27	32	39	54	19	
48"	50	62	73	64	79	93	78	97	115	108	133	158					30	36	44	61	21	
54"	57	71	85	74	92	110	91	113	136	126	157	188									21	
60"																					22	
66"																					25	
72"																					26	

() Endwall With Baffles

STATE OF FLORIDA DEPARTMENT OF TRANSPORTATION

DITCH PAVEMENT & SODDING

Designed By	Names	Dates	Approved By	
Drawn By	HSD	08/85	State Drainage Engineer	
Checked By	JBW/JVG	09/85	Revision	00
			Sheet No.	2 of 2
			Index No.	281