

Note: Not Applicable For Type C, D & E Ditch Bottom Inlets. See Index No. 232.

TOP SLAB REINFORCING STEEL DIAGRAM

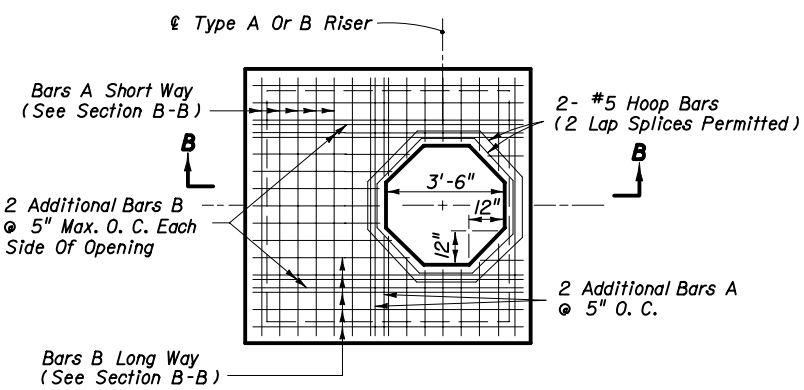

TOP SLAB REINFORCING STEEL DIAGRAM

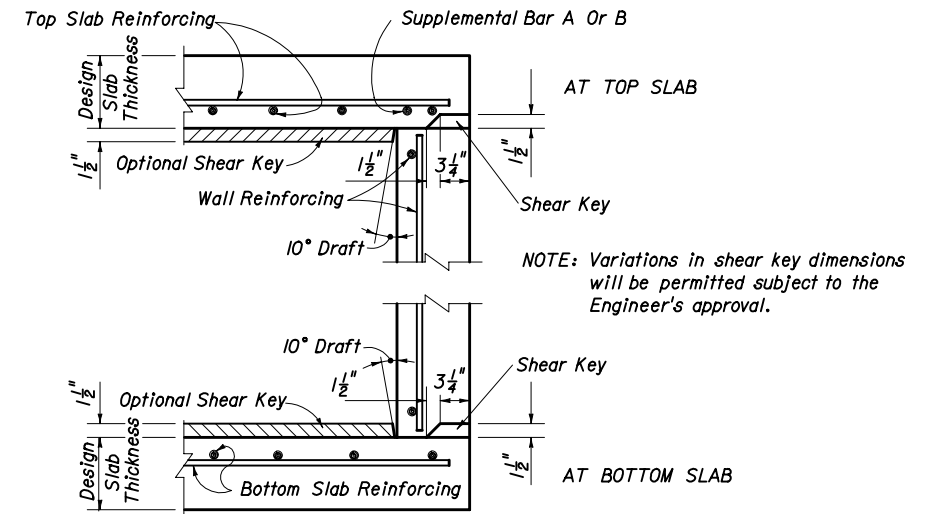

SLAB TO WALL DETAILS FOR PRECAST ALTERNATE WITH 8" WALLS

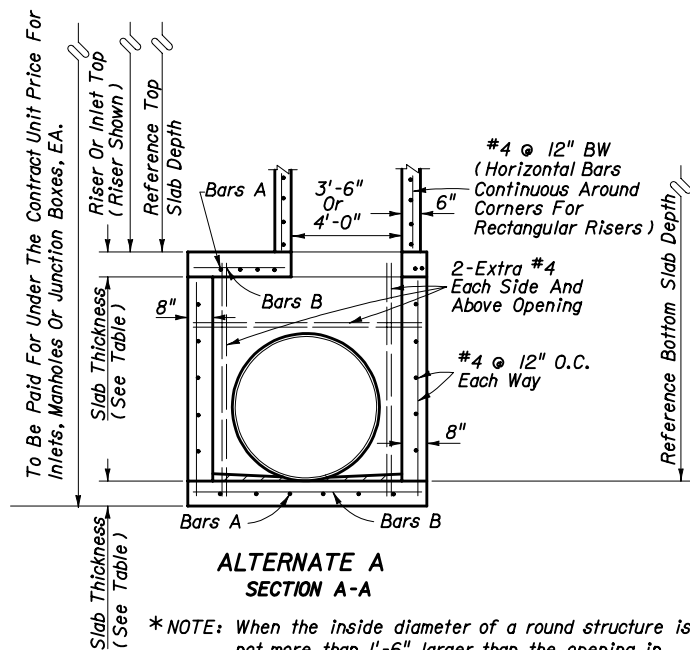

ALTERNATE A SECTION A-A

*NOTE: When the inside diameter of a round structure is not more than 1'-6" larger than the opening in the riser or top slab, the top of the structure or riser shall be constructed according to the "Special Top Slab" details on this sheet.

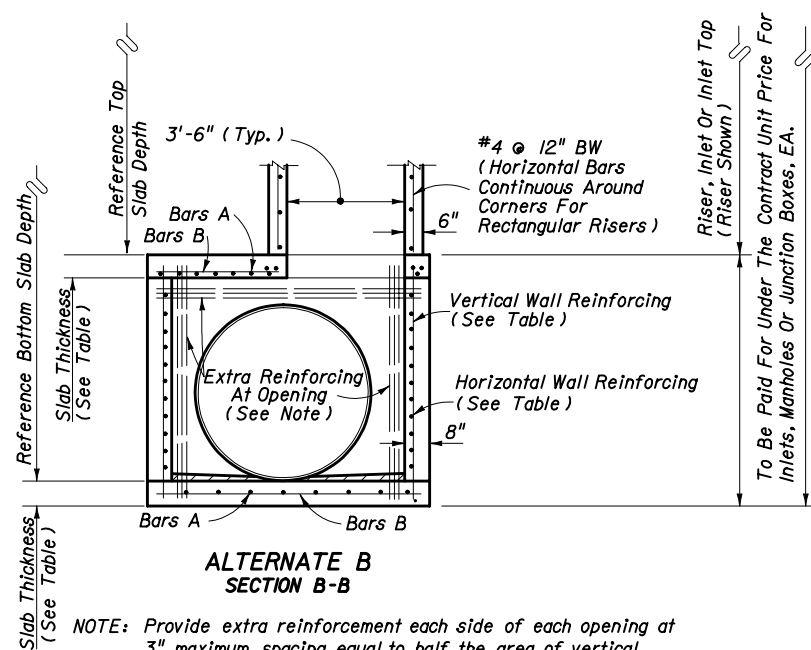

ALTERNATE B SECTION B-B

NOTE: Provide extra reinforcement each side of each opening at 3" maximum spacing equal to half the area of vertical reinforcement removed by the opening and provide the same area of reinforcement above each opening at 3" maximum spacing as removed by the opening.

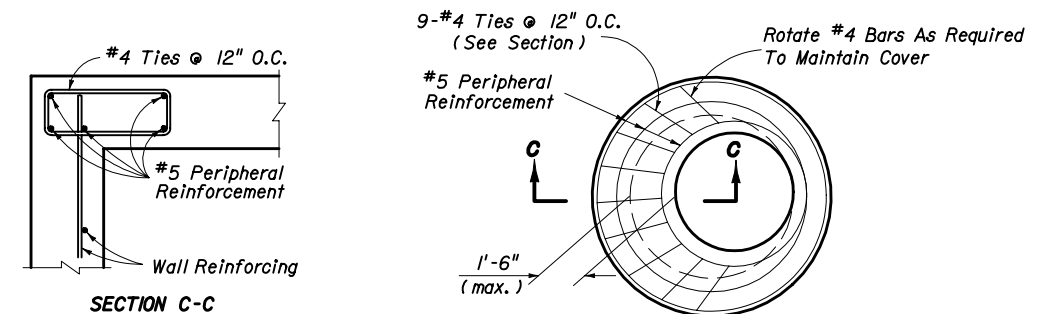

SPECIAL TOP SLAB*

GENERAL NOTES

- Standard structure bottoms 4'-0" diameter and smaller (Alt. A) and 3'-6" square (Alt. B) are designated Type P. Larger standard structure bottoms are designated Type J. Risers are permitted for all structures.
- Walls of circular structures (Alternate A) constructed in place may be of non-reinforced concrete or brick or reinforced concrete. Precast and rectangular structures (Alternate B) shall be constructed of reinforced concrete only.
- Wall thickness and reinforcement are for either reinforced cast-in-place or precast concrete units except that precast circular units may be furnished with walls in accordance with either ASTM C478 (up to 96" diameter) or ASTM C76, Class III, B Wall, modified where the elliptical steel cage area is placed in the center one-third of the wall.
- Top and floor slab thickness and reinforcement are for precast and cast in place construction. Top and floor slabs shall be of Class II concrete. Concrete as specified in ASTM C478 (4000 psi) may be used in lieu of Class I and Class II concrete in precast items manufactured in plants which are under the 'Standard Operating Procedures' for the inspection of precast drainage products.
- All reinforcement shown is ASTM A615/A615M Grade 60 steel, either smooth or deformed. Equivalent area Grade 40 steel or Grade 65KSI welded wire fabric may be substituted according to Index No. 201.
- Structure bottoms may be used in conjunction with curb inlet tops Types 1, 2, 3, 4, 5, 6, 9, and 10, and any manhole or junction box unless otherwise shown in the plans or other standard drawings. Alt. B structure bottoms may be used in conjunction with curb inlet Types 7 & 8, or any ditch bottom inlet unless otherwise shown in the plans or other standard drawings.
- Rectangular structures may be rotated as directed by the Engineer in order to facilitate connections between the structure walls and storm sewer pipes.
- Except when ACI hooks are specifically required, reinforcement top and slab shall be straight embedment.
- All steel bars shall have 1/2" minimum cover unless otherwise shown except for precast circular units manufactured under ASTM C76 or ASTM C478. Horizontal steel in rectangular structures shall be lapped a minimum of 24 bar diameters at corners.
- The corner fillets shown are necessary for rectangular structures used with circular risers and inlet throats and used on skew with rectangular risers, inlet and inlet throats. Fillets will be required in lieu of the bottom slab of the Alt. B riser when used with the Alt. A box. Each fillet shall be reinforced with 2-#5 bars.
- Inlet throats, riser or manhole tops shall be secured to structures as shown on Index No. 201.
- Structures with depths over 14' are to be checked for floatation by designer of project drainage.
- Units larger than specified standard may be substituted at the contractor's option when these units will not cause or increase the severity of utility conflicts. Such larger units shall be furnished at no additional cost to the Department. Larger Alternate A units cannot replace Alternate B units without approval of the Engineer. This note applies to this Index only.
- For manhole and junction box tops, for frames and covers, and, for supplementary details see Index No. 201.

STATE OF FLORIDA DEPARTMENT OF TRANSPORTATION				
STRUCTURE BOTTOMS TYPE J AND P				
Names	Dates	Approved By		
Designed By		State Drainage Engineer		
Drawn By		Revision	Sheet No.	Index No.
Checked By		00	1 of 2	200

SLAB DESIGNS - SQUARE AND RECTANGULAR STRUCTURES
(ALL SLABS 8" THICK - REINFORCING PARALLEL TO SHORT WAY AND LONG WAY)

SHORT-WAY		LONG-WAY	
SLAB DEPTH	SCHEDULE	SLAB DEPTH	SCHEDULE
SIZE: 3'-6" x UNLIMITED			
≥ 0.5' < 29'	B	≥ 0.5' < 40'	B
29' - 40'	C		
SIZE: 4'-0" x UNLIMITED			
≥ 0.5' < 19'	B	≥ 0.5' < 34'	B
19' < 29'	C	34' - 40'	C
29' - 40'	D		
SIZE: 5' x 5'			
≥ 0.5' < 3'	C	≥ 0.5' < 3'	C
3' < 19'	B	3' < 19'	B
19' < 28'	C	19' < 28'	C
28' < 38'	D	28' < 38'	D
38' - 40'	F	38' - 40'	F
SIZE: 5' x 6'			
≥ 0.5' < 3'	C	≥ 0.5' < 3'	C
3' < 16'	B	3' < 20'	B
16' < 24'	C	20' < 29'	C
24' < 34'	D	29' - 40'	D
34' - 40'	F		
SIZE: 5' x 7'			
≥ 0.5' < 3'	C	≥ 0.5' < 3'	C
3' < 14'	B	3' < 22'	B
14' < 21'	C	22' < 33'	C
21' < 39'	D	33' - 40'	D
39' - 40'	F		
SIZE: 5' x 8'			
≥ 0.5' < 3'	C	≥ 0.5' < 39'	B
3' < 8'	B	39' - 40'	C
8' < 17'	C		
17' < 23'	D		
23' - 40'	F		
SIZE: 5' x 9'			
≥ 0.5' < 3'	C	≥ 0.5' < 32'	B
3' < 8'	B	32' - 40'	C
8' < 17'	C		
17' < 23'	D		
23' - 40'	F		

SHORT-WAY		LONG-WAY	
SLAB DEPTH	SCHEDULE	SLAB DEPTH	SCHEDULE
SIZE: 6' x 6'			
≥ 0.5' < 3'	D	≥ 0.5' < 3'	D
3' < 4'	C	3' < 4'	C
4' < 14'	B	4' < 14'	B
14' < 21'	C	14' < 21'	C
21' < 28'	D	21' < 28'	D
28' - 40'	F	28' - 40'	F
SIZE: 6' x 7'			
≥ 0.5' < 3'	D	≥ 0.5' < 3'	D
3' < 4'	C	3' < 4'	C
4' < 12'	B	4' < 15'	B
12' < 19'	C	15' < 21'	C
19' < 26'	D	21' < 30'	D
26' - 40'	F	30' - 40'	F
SIZE: 6' x 8'			
≥ 0.5' < 3'	D	≥ 0.5' < 3'	D
3' < 4'	C	3' < 4'	C
4' < 7'	B	4' < 16'	B
7' < 16'	C	16' < 23'	C
16' < 23'	D	23' < 32'	D
23' - 40'	F	32' - 40'	F
SIZE: 6' x 9'			
≥ 0.5' < 3'	D	≥ 0.5' < 3'	D
3' < 15'	C	3' < 4'	C
15' < 21'	D	4' < 18'	B
21' < 27'	E	18' < 27'	C
27' - 40'	G	27' < 37'	D
		37' - 40'	E
SIZE: 7' x 7'			
≥ 0.5' < 3'	E	≥ 0.5' < 3'	E
3' < 4'	D	3' < 4'	D
4' < 16'	C	4' < 16'	C
16' < 22'	D	16' < 22'	D
22' < 28'	E	22' < 28'	E
28' - 40'	G	28' - 40'	G
SIZE: 7' x 8'			
≥ 0.5' < 3'	E	≥ 0.5' < 3'	E
3' < 4'	D	3' < 4'	D
4' < 15'	C	4' < 17'	C
15' < 21'	D	17' < 23'	D
21' < 27'	E	23' < 29'	E
27' - 40'	G	29' - 40'	G
SIZE: 7' x 9'			
≥ 0.5' < 3'	E	≥ 0.5' < 3'	E
3' < 4'	D	3' < 4'	D
4' < 12'	C	4' < 18'	C
12' < 18'	D	18' < 24'	D
18' < 24'	E	24' < 32'	E
24' - 40'	G	32' - 40'	G

SHORT-WAY		LONG-WAY	
SLAB DEPTH	SCHEDULE	SLAB DEPTH	SCHEDULE
SIZE: 8' x 8'			
≥ 0.5' < 3'	D	≥ 0.5' < 3'	D
3' < 4'	C	3' < 4'	C
4' < 9'	B	4' < 9'	B
9' < 17'	C	9' < 17'	C
17' < 31'	D	17' < 31'	D
31' - 40'	G	31' - 40'	G
SIZE: 8' x 9'			
≥ 0.5' < 3'	D	≥ 0.5' < 3'	E
3' < 4'	C	3' < 4'	D
4' < 16'	B	4' < 18'	C
16' < 22'	C	18' < 25'	D
22' < 29'	D	25' < 32'	F
29' - 40'	F	32' - 40'	G
SIZE: 9' x 9'			
≥ 0.5' < 3'	F	≥ 0.5' < 3'	F
3' < 14'	C	3' < 14'	C
14' < 20'	D	14' < 20'	D
20' < 26'	E	20' < 26'	E
26' - 40'	G	26' - 40'	G

SLAB DESIGNS - ROUND STRUCTURES

SLAB DEPTH	SLAB THICKNESS	REINFORCING (2 WAYS) SCHEDULE
SIZE: 3'-6"		
≥ 0.5' - 40'	8"	C
SIZE: 4'-0"		
≥ 0.5' - 40'	8"	C
SIZE: 5'-0"		
≥ 0.5' < 30'	8"	C
30' - 40'	8"	D
SIZE: 6'-0"		
≥ 0.5' < 8'	8"	B
8' < 18'	8"	C
18' < 30'	8"	D
30' < 37'	8"	E
37' - 40'	8"	G
SIZE: 8'-0"		
≥ 0.5' < 9'	10"	C
9' < 15'	10"	D
15' < 23'	10"	E
23' < 33'	12"	E
33' - 40'	12"	G
SIZE: 10'-0"		
≥ 0.5' < 6'	10"	C
6' < 11'	10"	D
11' < 17'	10"	E
17' < 23'	12"	E
23' - 40'	12"	G
SIZE: 12'-0"		
≥ 0.5' < 6'	12"	C
6' < 11'	12"	D
11' < 16'	12"	E
16' < 20'	14"	E
20' - 40'	14"	G

WALL DESIGNS - RECTANGULAR STRUCTURES

VERTICAL REINFORCING		HORIZONTAL REINFORCING	
WALL DEPTH	SCHEDULE	WALL DEPTH	SCHEDULE
SIZE: 3'-6" * SEE NOTE BELOW			
≥ 1.17' - 40'	A	≥ 1.17' - 40'	B
SIZE: 4'-0"			
≥ 1.17' - 40'	A	≥ 1.17' - 40'	B
SIZE: 5'-0"			
≥ 1.17' - 40'	A	≥ 1.17' < 33'	B
		33' - 40'	C
SIZE: 6'-0"			
≥ 1.17' - 40'	A	≥ 1.17' < 22'	B
		22' - 40'	C
SIZE: 7'-0"			
≥ 1.17' - 40'	A	≥ 1.17' < 15'	B
		15' < 25'	C
		25' - 40'	D
SIZE: 8'-0"			
≥ 1.17' - 40'	A	≥ 1.17' < 11'	B
		11' < 19'	C
		19' < 29'	D
		29' - 40'	F
SIZE: 9'-0"			
≥ 1.17' - 40'	A	≥ 1.17' < 15'	C
		15' < 22'	D
		22' - 40'	F

* Precast structures 3'-6" x 3'-6" maybe cast with 6" walls to depths of 15'. See Index No. 201.

GENERAL NOTES

- Size is the inside dimension(s) of a structure.
- Slab reinforcement is appropriate for top, intermediate, and bottom slabs.
- Slab depth is measured from finished grade to top of slab.
- Wall design depth is measured to the top of the bottom slab for boxes and to the top of the intermediate slab for risers.
- Wall height is the distance between top of lower slab to bottom of upper slab.
- Wall sizes exceeding 9'-0" require a special design.

REINFORCING SCHEDULE

SCHEDULE	GRADE 60 STEEL OR 65 KSI (WIRE FABRIC) In ² /ft
A	0.20
B	0.24
C	0.37
D	0.53
E	0.73
F	1.06
G	1.45

STATE OF FLORIDA DEPARTMENT OF TRANSPORTATION

**STRUCTURE BOTTOMS
TYPE J AND P**

Names	Dates	Approved By			
Designed By		<i>[Signature]</i>	State Design Engineer		
Drawn By	ods 05/86	Revision	Sheet No.	Index No.	
Checked By	JBW 05/86	04	2 of 2	200	