

SELECTION PROCEDURE

- Determine the required pole height and bending moment at the pole base using a design wind speed in conformance with the "Plans Preparation Manual", Chapter 29, with a 30 percent gust factor.
- Enter the Pole Moment Capacity Table, and determine the required Pole Type and wall thickness.
- Enter the Pole Type and height designation in the signalization Plans for each strain pole.
Example: From design: required height = 23'-6",
base moment = 198.0 kip-ft
From tables use NS-VII-24
- Refer to the Table of Variables for the required pole diameter, base plate and drilled shaft dimensions.

D (ft.)	TYPE OF POLE						
	NS-IV	NS-V	NS-VI	NS-VII	NS-VIII	NS-IX	NS-X
20	33.0	106.0	152.0	210.0	266.0	330.0	390.0
22	36.8	111.2	158.7	218.0	274.9	340.3	401.7
24	40.6	116.4	165.3	226.0	283.9	350.7	413.3
26	44.4	121.6	172.0	234.0	292.8	361.0	425.0
28	48.2	126.8	178.7	242.0	301.7	371.3	436.7
30	52.0	132.0	185.3	250.0	310.7	381.7	448.3
32	55.8	137.2	192.0	258.0	319.6	392.0	460.0
34	59.6	142.4	198.7	266.0	328.5	402.3	471.7
36	63.4	147.6	205.3	274.0	337.5	412.7	483.3
38	67.2	152.8	212.0	282.0	346.4	423.0	495.0
40	71.0	158.0	218.7	290.0	355.3	433.3	506.7
42	74.8	163.2	225.3	298.0	364.3	443.7	518.3
44	78.6	168.4	232.0	306.0	373.2	454.0	530.0
46	82.4	173.6	238.7	314.0	382.1	464.3	541.7
48	86.2	178.8	245.3	322.0	391.1	474.7	553.3
50	90.0	184.0	252.0	330.0	400.0	485.0	565.0

0.239 Inch Wall Thickness

0.313 Inch Wall Thickness

STEEL STRAIN POLE NOTES

- Signal Structure Materials shall be as follows:
 - Poles --> ASTM A1011 Grade 50, 55, 60, or 65 (less than 1/4") or ASTM A572 Grade 50, 55, 60, or 65 (1/4" and over) or ASTM A595 Grade A (55 ksi yield) or Grade B (60 ksi yield)
 - Steel Plates --> ASTM A709 Grade 36
 - Weld Metal --> E70XX
 - Bolts (except Anchor Bolts) --> ASTM A325, Type 1
 - Anchor Bolts --> ASTM F1554 Grade 55
 - Nuts for Anchor Bolts --> ASTM A563 Grade A Heavy Hex
 - Washers for Anchor Bolts --> ASTM F436 Type 1
 - Handhole Frame --> ASTM A709 Grade 36 or ASTM A36
 - Handhole Cover --> ASTM A1011 Grade 50, 55, 60, or 65
 - Aluminum Caps and Covers --> ASTM B26 (319-F)
 - Stainless Steel Screws --> AISI Type 316
- All Steel Items shall be Galvanized as follows:
 - All Nuts, Bolts and Washers --> ASTM A153 Class C or D depending on size
 - All other Steel Items --> ASTM A123
- Concrete shall be Class IV (Drilled Shaft) with a minimum 28-day Compressive Strength (f'c) of 4,000 psi for all environmental classifications.
- Reinforcing Steel shall be ASTM A615-96 Grade 60.
- Grout shall have a minimum 28-day Compressive Strength of 5,000 psi and shall meet the requirements of Section 934. Grout after pole is set and properly plumbed.
- A design wind speed of 100 mph with a 30% gust factor for wind loading on the pole was included in the design.
- The Pole shall be tapered with the diameter changing at a rate of 0.4 Inch per foot.
- Except for anchor bolts, all bolt hole diameters shall be equal to the bolt diameter plus 1/16", prior to galvanizing. Hole diameters for anchor bolts shall not exceed the bolt diameter plus 1/2".
- The foundation for the Strain Pole Structure shall be constructed in accordance with Section 455 of the FDOT Specifications except that no payment for the foundation shall be made under Section 455. The cost of providing the foundation shall be included in the pay item for providing the complete Strain Pole Structure. For foundation design assumptions, refer to the Foundation Notes.
- The pole shall be free of transverse welds except at the base.
- Poles constructed out of two or more sections with overlapping splices are not permitted.
- The strain pole shall not be erected until the foundation concrete has been allowed to cure for a minimum of seven days.
- No field welding on any part of the pole is permitted.
- For clamp spacing, cable sizes and forces, signal and sign mounting locations and details see the Signalization Plans.
- All welding shall conform to American Welding Society Structural Welding Code (Steel) ANSI/AWS D1.1 (current edition).
- See Standard Index No. 17727 for grounding detail and span wire installation details.
- Locate handhole 180° from 2 inch wire entrance pipe.
- Paint Steel Strain Poles in accordance with Section 649, Mast Arm Assemblies.

Aluminum Identification Tag Not to Exceed 2" x 4". Secure to Shaft by 0.125" Stainless Steel rivets or screws. Fabricators to provide details for approval. Identification Tag Located on Inside of Pole visible from handhole. Tag to be stamped with the following information:

Financial Project ID
Pole Type
Pole Height
Manufacturer's Name
Certification No.

ELEVATION AND NOTES

STATE OF FLORIDA DEPARTMENT OF TRANSPORTATION				
STEEL STRAIN POLE				
Designed By	RK	9-00	Approved By <i>[Signature]</i> State Structures Design Engineer	
Drawn By	JMB	9-00	Revision	Sheet No. Index No.
Checked By	DER	9-00	04	1 of 3 17723

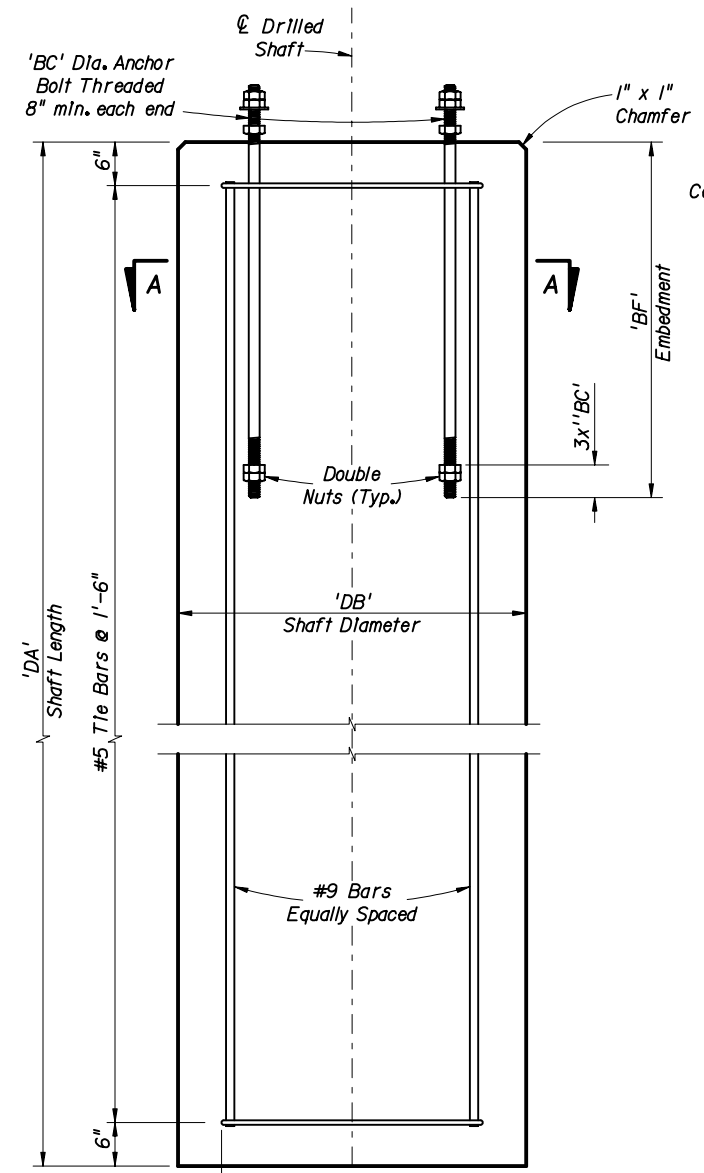

DRILLED SHAFT ELEVATION
(See Table for number of #9 bars.)

FOUNDATION NOTES:
The foundations for Steel Strain Poles are pre-designed and are based upon the following conservative soil criteria which covers the great majority of soil types found in Florida:
Classification = Cohesionless (Fine Sand)
Friction Angle = 30 Degrees (30°)
Unit Weight = 50 lbs./cu. ft. (assumed saturated)

Only in cases where the Designer considers the soil types at the specific site location to be of lesser strength properties should an analysis be required. Auger borings, SPT borings or CPT soundings may be utilized as needed to verify the assumed soil properties, and at relatively uniform sites, a single boring or sounding may cover several foundations. Furthermore, borings in the area that were performed for the other purposes may be used to confirm the assumed soil properties.

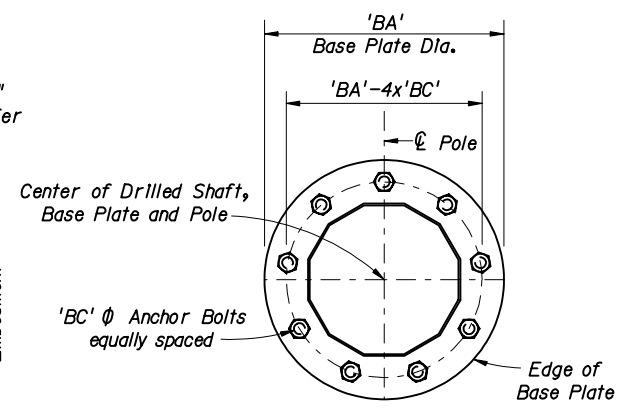

VIEW B-B
NOTE: Number of bolts shown for illustration purposes only. (See Table for actual quantity)

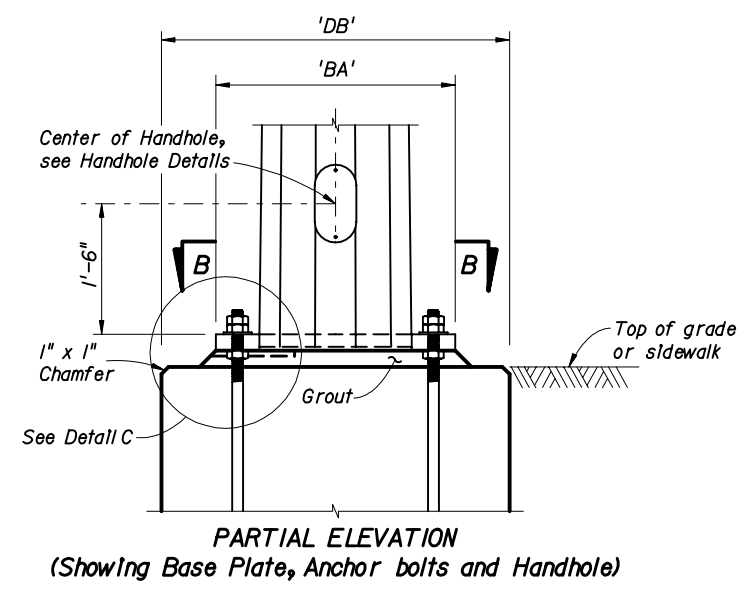

PARTIAL ELEVATION
(Showing Base Plate, Anchor bolts and Handhole)

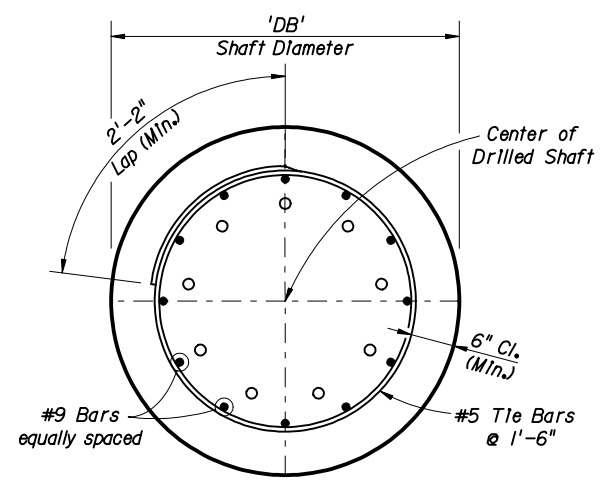

SECTION A-A

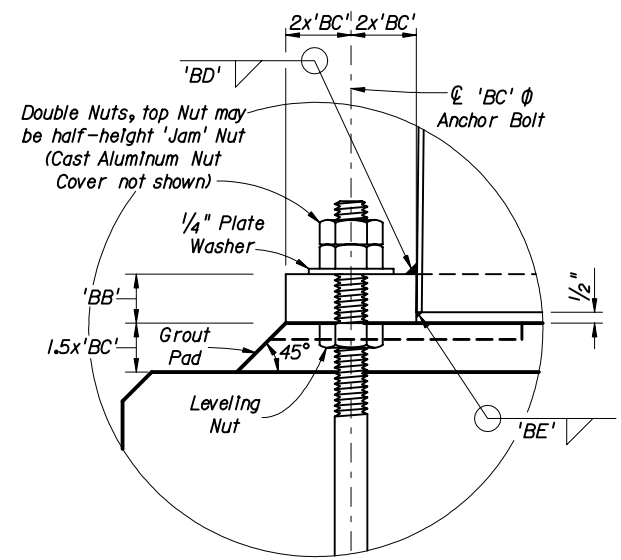

DETAIL C

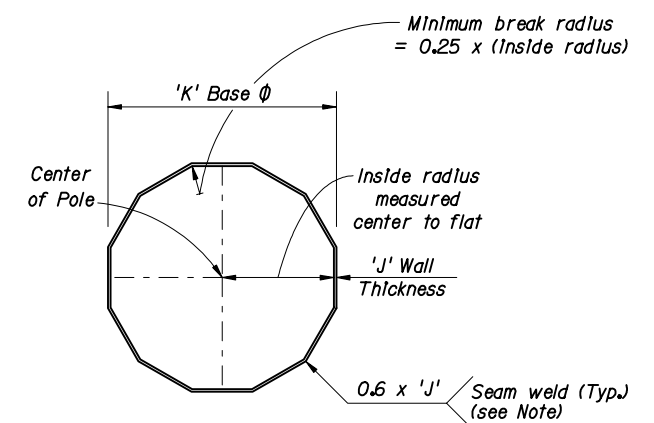

POLE SECTION

NOTE: Longitudinal seam welds within 6" of circumferential welds shall be complete penetration welds.

POLE TYPE	TABLE OF STRAIN POLE VARIABLES											
	POLE		BASE CONNECTION							SHAFT		
	J (In.)	K (In.)	No. of Bolts	BA (In.)	BB (In.)	BC (In.)	BD (In.)	BE (In.)	BF (In.)	DA (ft)	DB (ft)	No. of #9 bars
NS-IV	J = 0.239	14	6	25	2.125	1.375	0.313	0.188	36	10	3.5	14
NS-V		16	8	27	2.250	1.375	0.375	0.188	47	12.5	3.5	14
NS-VI		18	8	30	2.375	1.500	0.438	0.188	54	14	3.5	14
NS-VII		21	10	33	2.250	1.500	0.375	0.188	49	15	4	19
NS-VIII		23	12	34	2.250	1.375	0.375	0.188	52	16	4	19
NS-IX		25	12	37	2.250	1.500	0.375	0.188	50	16	4.5	23
NS-X		27	12	39	2.375	1.500	0.375	0.188	52	17	4.5	23
NS-V	J = 0.313	16	8	28	2.375	1.500	0.438	0.250	47	12.5	3.5	14
NS-VI		18	10	30	2.375	1.500	0.500	0.250	54	14	3.5	14
NS-VII		21	12	33	2.375	1.500	0.500	0.250	49	15	4	19
NS-VIII		23	12	35	2.500	1.500	0.500	0.250	52	16	4	19
NS-IX		25	12	39	2.625	1.750	0.500	0.250	50	16	4.5	23
NS-X		27	12	41	2.750	1.750	0.500	0.250	52	17	4.5	23

Note: Details shown on this sheet are for 12 sided pole sections. However, sections with more than 12 sides and round sections are permitted, provided the outside diameter and well thickness are not reduced.

BASE DETAILS AND TABLE OF VARIABLES

STATE OF FLORIDA DEPARTMENT OF TRANSPORTATION

STEEL STRAIN POLE

Names	Dates	Approved By
Designed By: RK	9-00	[Signature] State Structures Design Engineer
Drawn By: JMB	9-00	
Checked By: DER	9-00	
Revision	Sheet No.	Index No.
02	2 of 3	17723

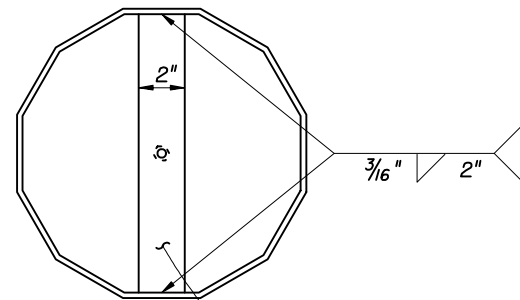
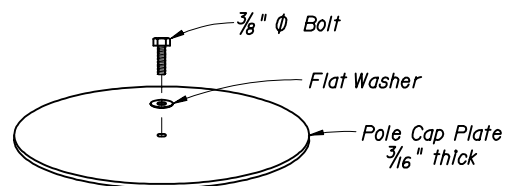

TOP VIEW

1/4" x 2" Lifting Bar with 5/16" ϕ hole and 3/8" Nut tack welded to underside of bar

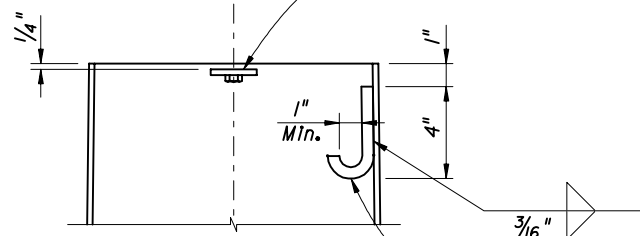

POLE TOP CUT-AWAY (Option 'a')

'J' Hook for wiring, 1/2" ϕ commercial grade hot rolled bar welded to inside of pole.

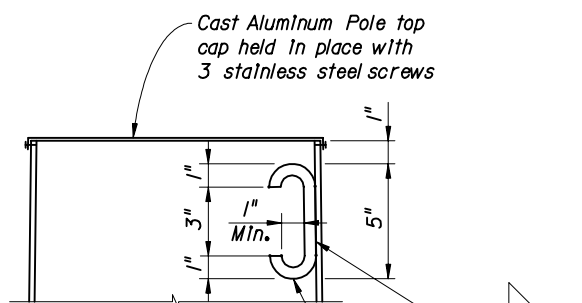

POLE TOP CUT-AWAY (Option 'b')

'C' Hook for wiring and lifting, 1/2" ϕ commercial grade hot rolled bar welded to inside of pole.

POLE TOP NOTE:
Any combination of the above two options may be used, provided both lifting and wiring is accommodated.

NOTE: A properly sized Service Head (Weather Head), shall be installed and fastened securely on to the standard pipe for each pole location. At locations other than service entrance, the service head face is to be left closed to outside atmosphere. Service entrance installation per Index No. 17727.

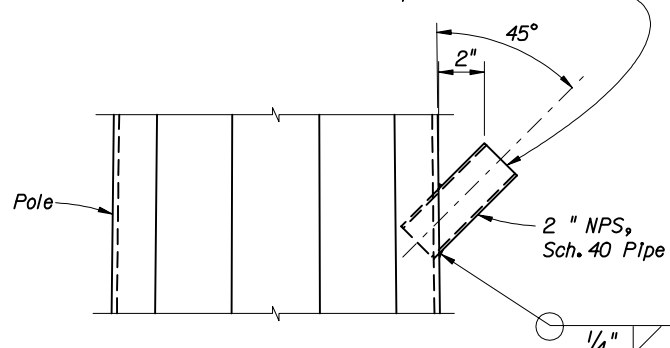

WIRE ENTRANCE DETAILS

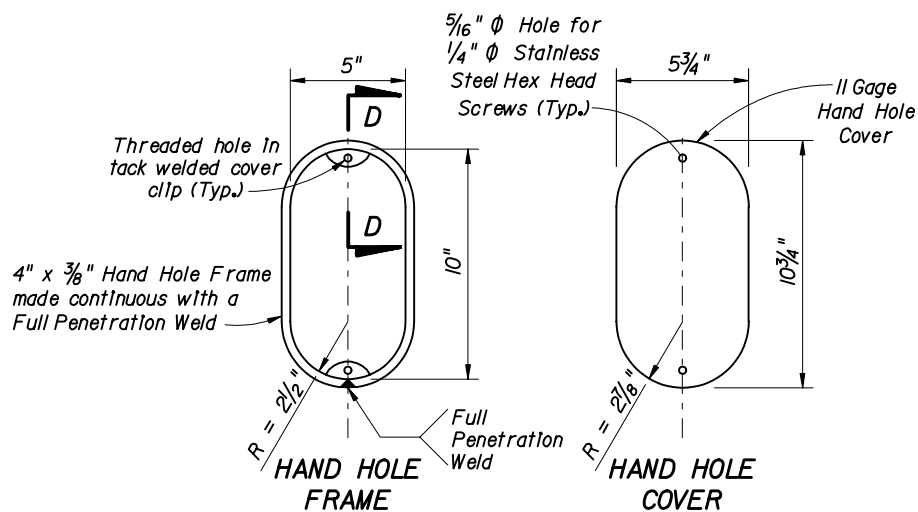

HAND HOLE FRAME

HAND HOLE COVER

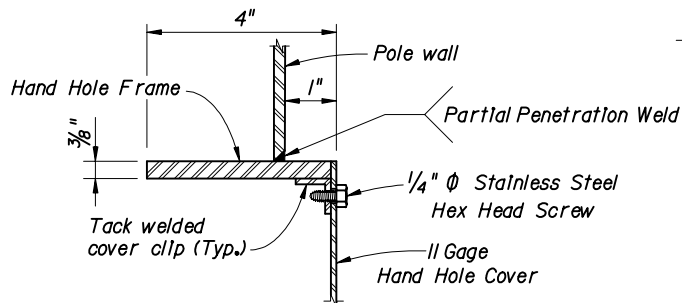

SECTION D-D (thru Hand Hole)

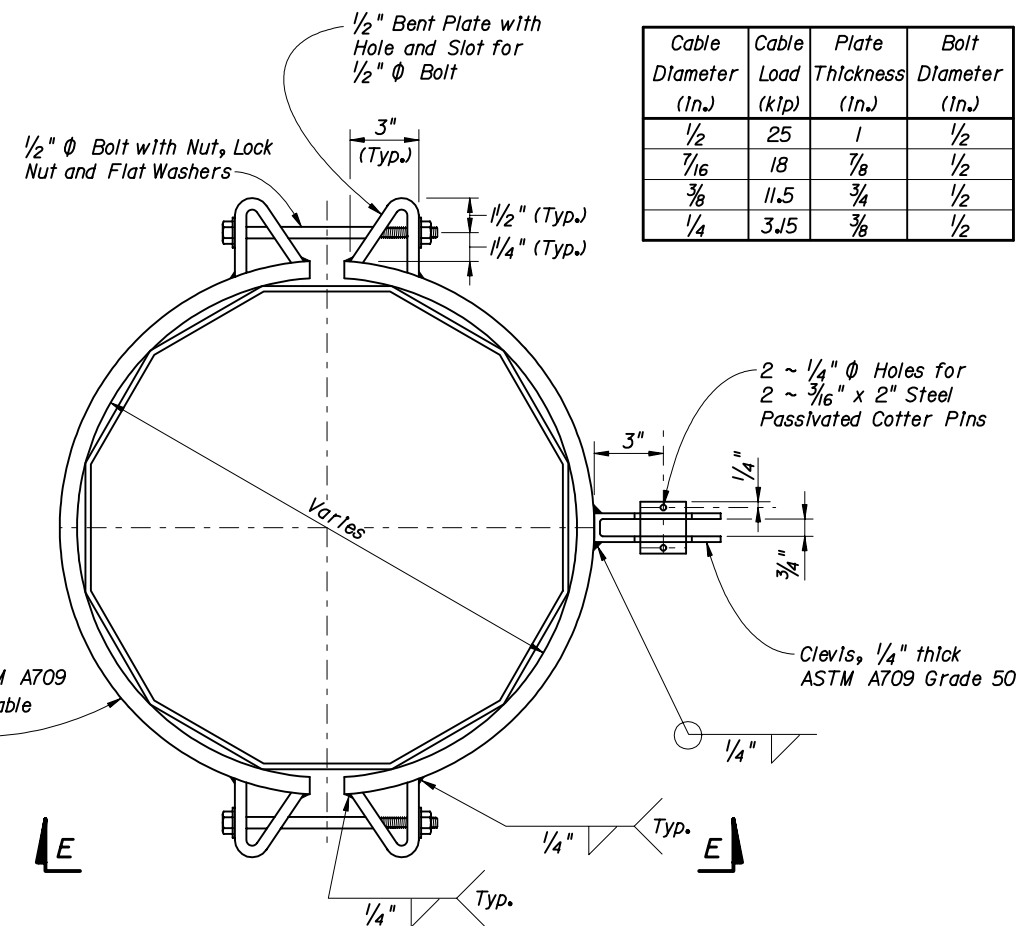

CATENARY AND MESSENGER WIRE CLAMPS

NOTE: Clamps have been sized for Design Cable Loads shown in the Table, and a Maximum Pole Diameter at the Clamp location of 2'-1".

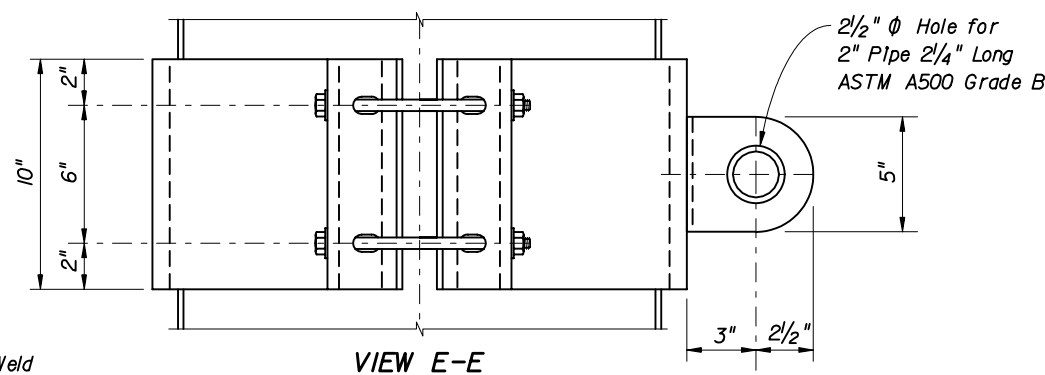

VIEW E-E

ATTACHMENT DETAILS

STATE OF FLORIDA DEPARTMENT OF TRANSPORTATION

STEEL STRAIN POLE

Names	Dates	Approved By
Designed By: RK	9-00	[Signature]
Drawn By: JMB	9-00	
Checked By: DER	9-00	

Revision	Sheet No.	Index No.
04	3 of 3	17723