

Crossing Shoulder Pavement (Except Area Occupied By Crossing Surfacing Material):
 (a) To Shoulder Line For Outside Shoulders Less Than 8' Wide.
 (b) To 8' Maximum Width For Outside Shoulders 8' Or Wider (Regardless Of Approach Shoulder Pavement Width).
 (c) 4' For Median Shoulders.

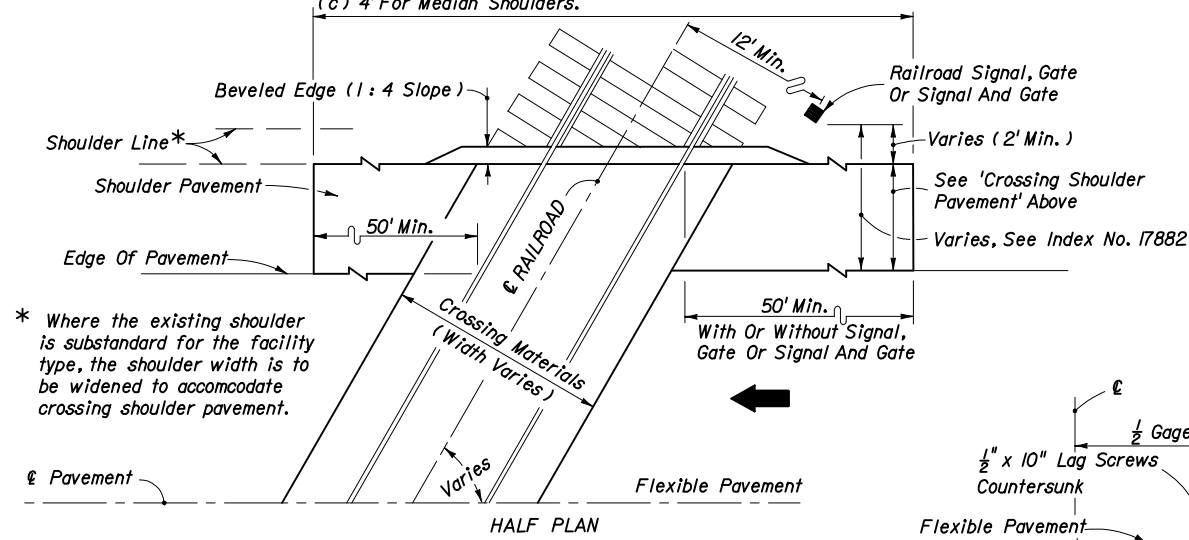

ROADWAYS WITH FLUSH SHOULDERS

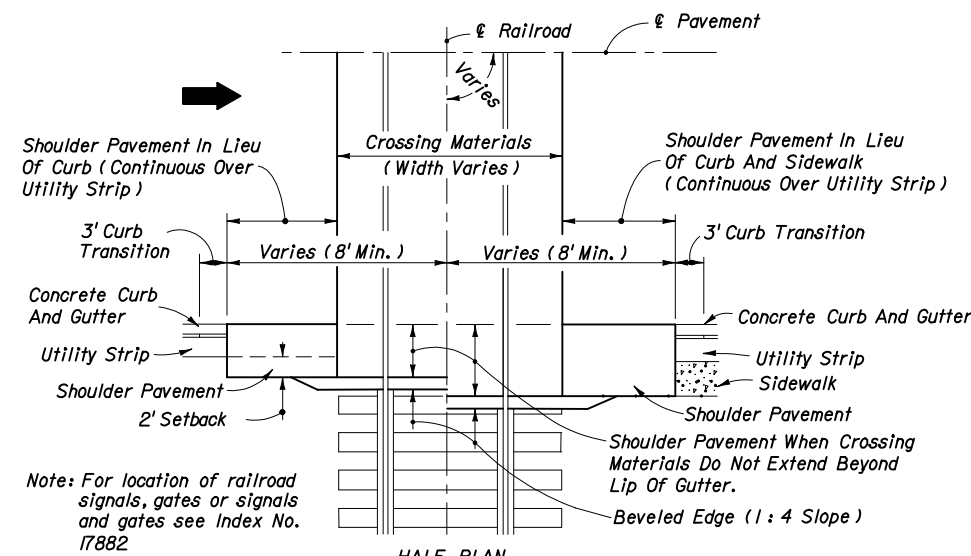

CURBED ROADWAYS

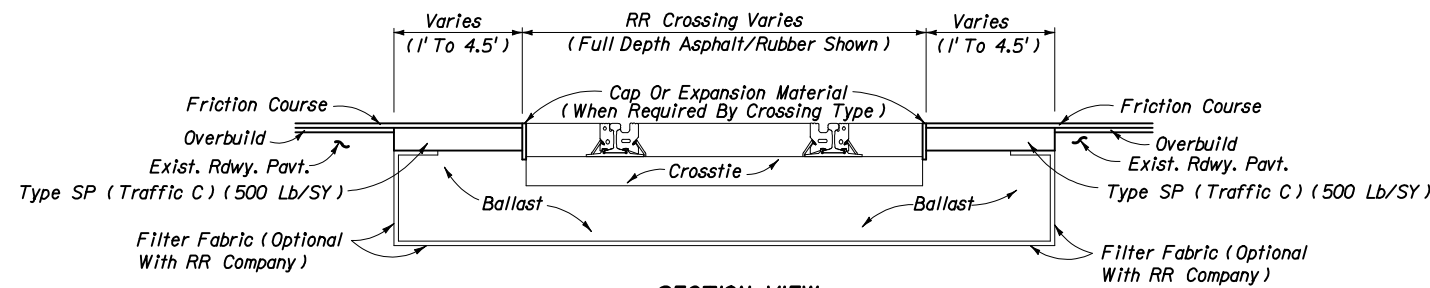

TYPICAL FLEXIBLE PAVEMENT REPLACEMENT AT RR CROSSINGS

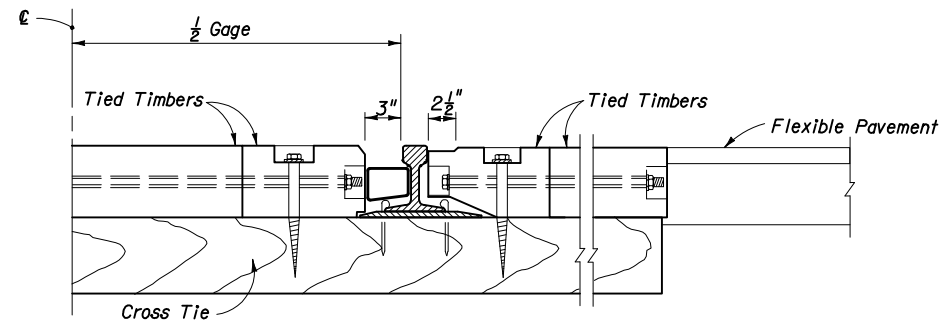

HALF SECTION TYPE D

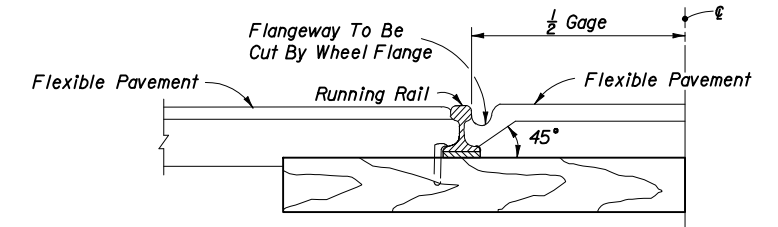

HALF SECTION TYPE E

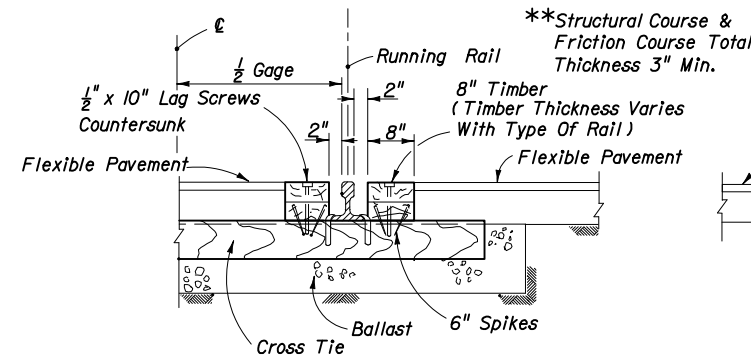

HALF SECTION TYPE G

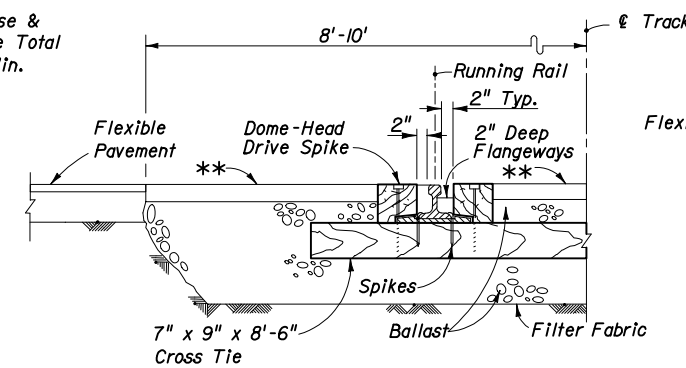

HALF SECTION TYPE G MODIFIED

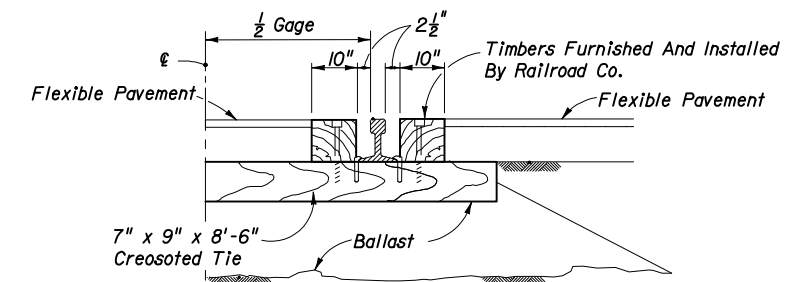

HALF SECTION TYPE H

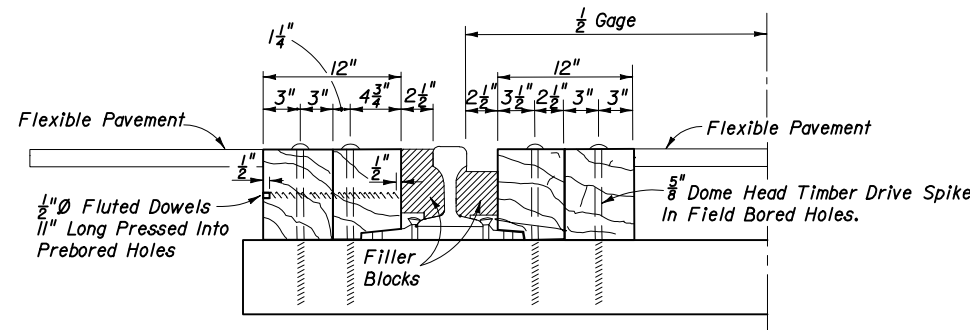

HALF SECTION TYPE L

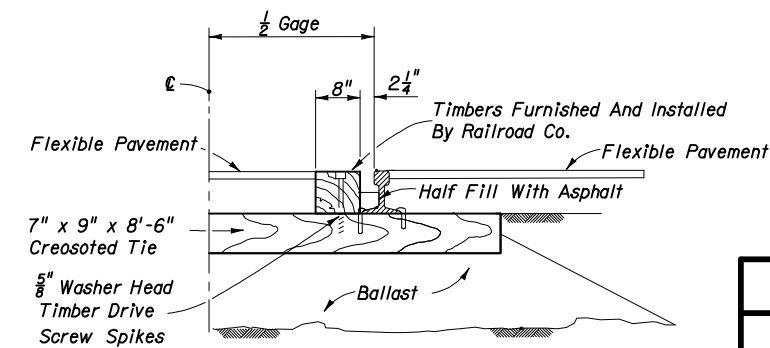

HALF SECTION TYPE S

NOTES

- The Railroad Company will furnish and install all track bed (ballast), crossties, rails, crossing surface panels and accessory components. All pavement material, including that through the crossing, will be furnished and installed by the Department or its Contractor, unless negotiated otherwise.
- Gage is standard A.R.E.A. track gage of 4'-8 1/2" (56 1/2").

STATE OF FLORIDA DEPARTMENT OF TRANSPORTATION

RAILROAD CROSSINGS

Names	Dates	Approved By		
Designed By		 State Roadway Design Engineer		
Drawn By	HW 08/69			
Checked By	JKC 08/69			
Revision	02			
Sheet No.	1 of 5	Index No.	560	

TYPES D, E, G, G-MOD., H, L AND S

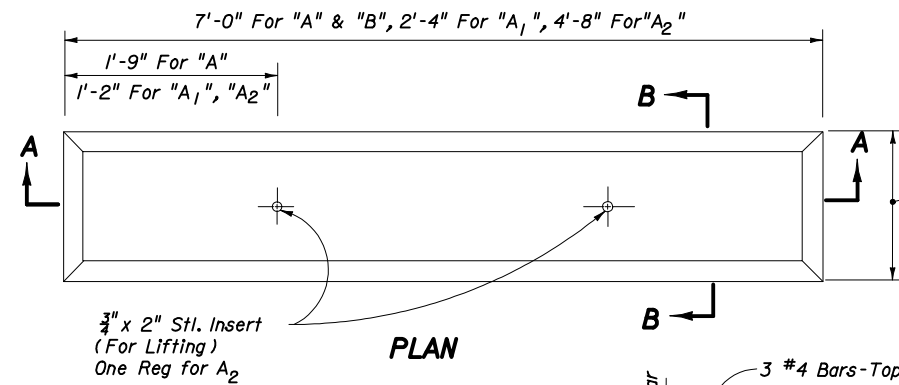

PLAN

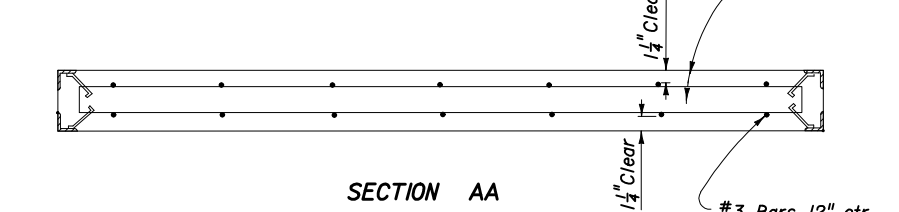

SECTION AA

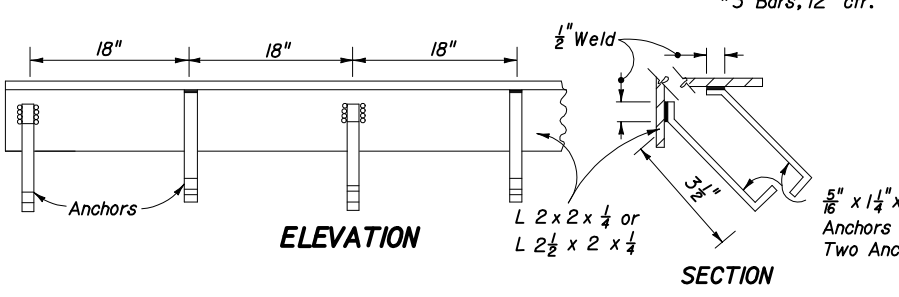

ELEVATION

SECTION

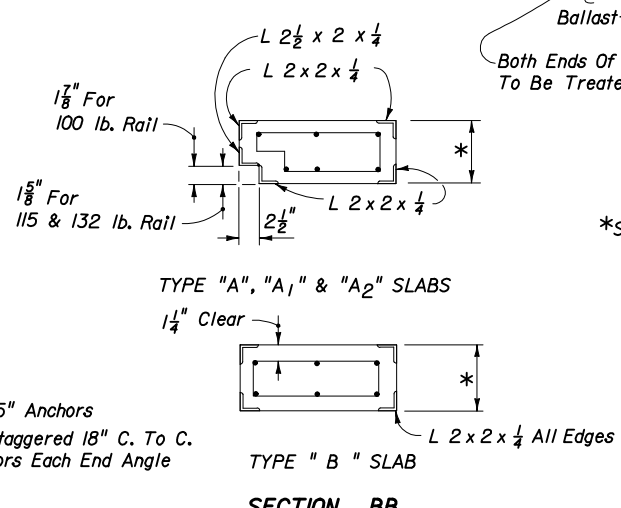

TYPE "A", "A1" & "A2" SLABS

TYPE "B" SLAB

SECTION BB

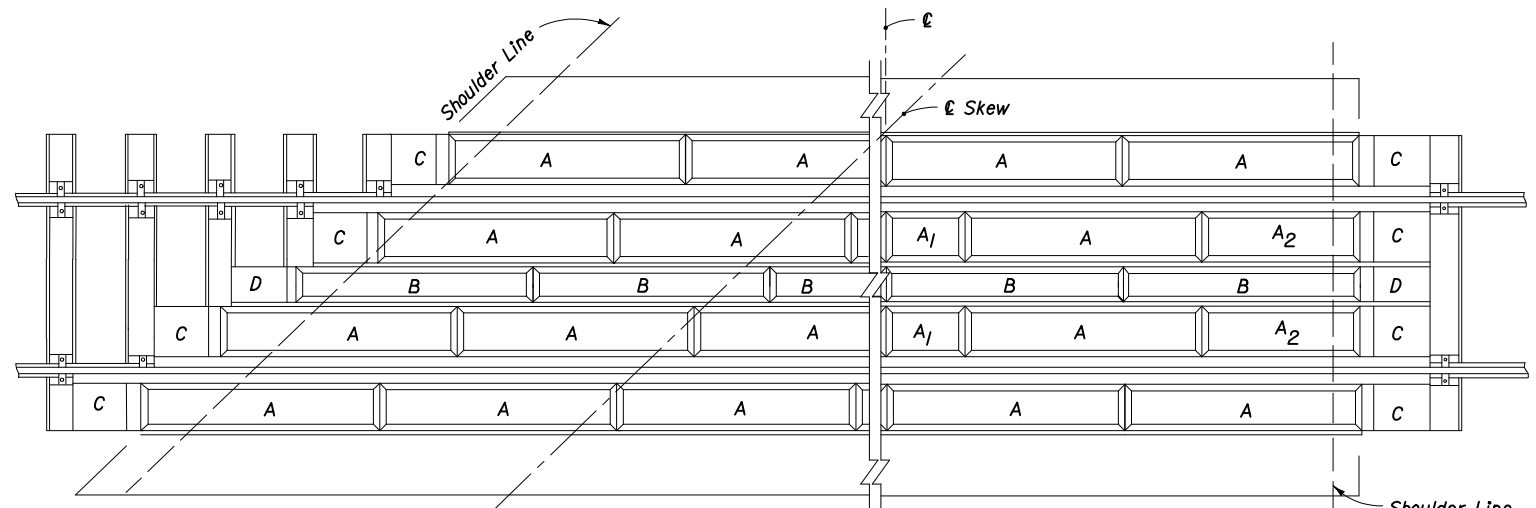

PLAN OF SKEWED CROSSING

PLAN-90° CROSSING

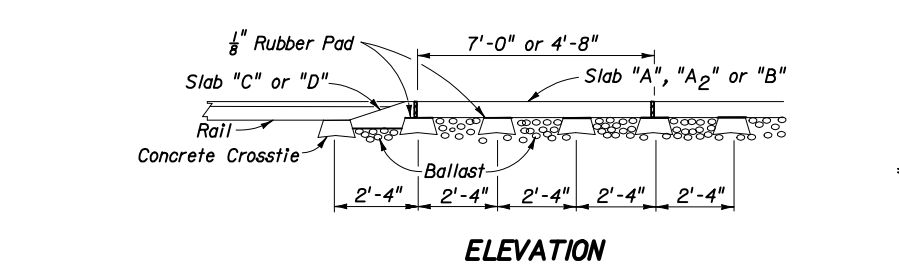

ELEVATION

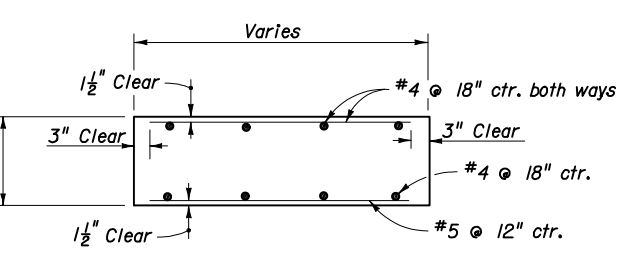

CONCRETE PAVING BETWEEN MULTIPLE CROSSINGS
(Cost Of Reinforcing To Be Included In The Cost Of Concrete, See Note No. 6)

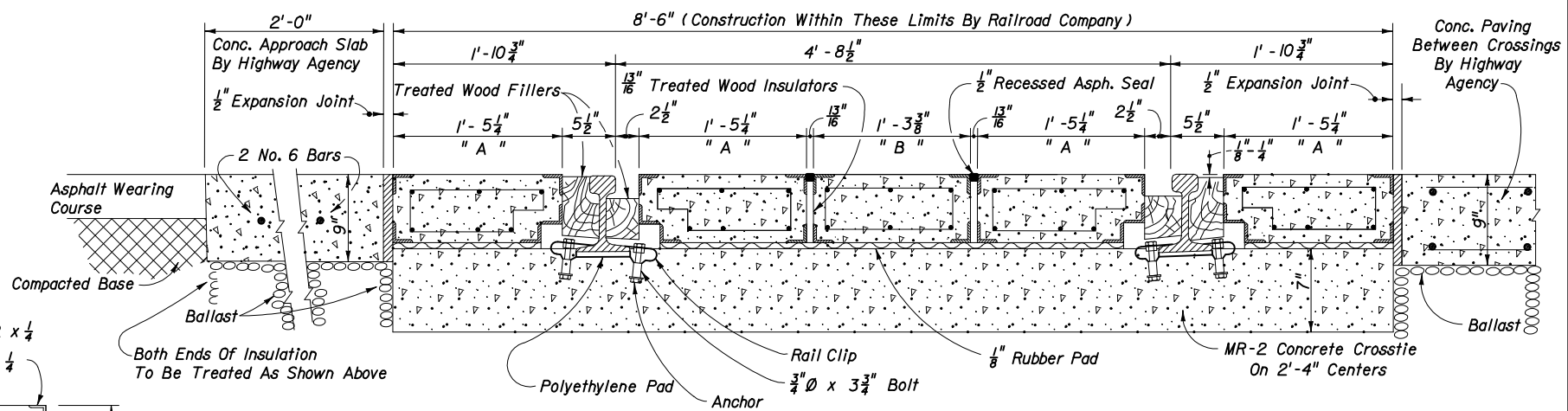

SECTION THRU CROSSING

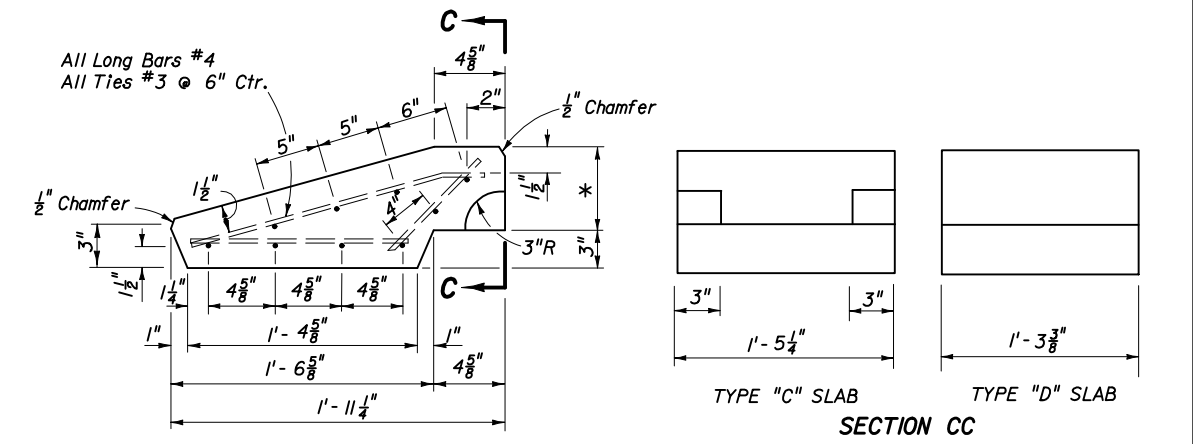

TYPE "C" & "D" SLAB DETAILS

NOTES

1. The furnishing and installing of concrete crossties together with any necessary reballasting, grade adjustment and track alignment shall be done by the Railroad Company without cost to the Contractor or to the Highway Agency.
2. All concrete slabs, rubber pads for tops of ties and wood filler blocks shall be furnished and installed by the Railroad Company.
3. Concrete crossties shall be spaced on 28" centers.
4. Rubber pads shall be installed on concrete ties in field using contact cement.
5. Filler blocks shall be pressure treated pine or clear heart redwood and shall be shaped prior to treatment.
6. Cost of concrete and reinforcing steel necessary for approach slabs and paving between multiple crossings shall be paid for by the Highway Agency under the contract unit price for Cement Concrete Pavement Reinforced, (9"), SY.

TYPE K

STATE OF FLORIDA DEPARTMENT OF TRANSPORTATION				
RAILROAD CROSSINGS				
Designed By	Names	Dates	Approved By	
Drawn By	HW	08/69	<i>Beim Bluebird</i> State Roadway Design Engineer	
Checked By	JKC	08/69	Revision	Sheet No.
			00	2 of 5
				560

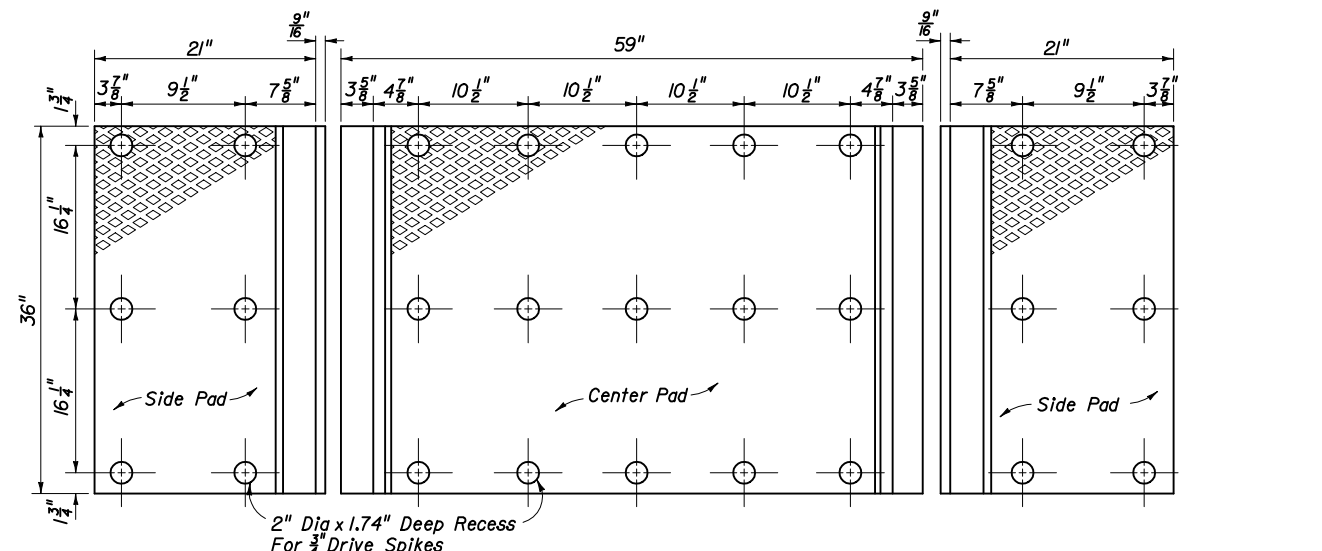

TOP VIEW

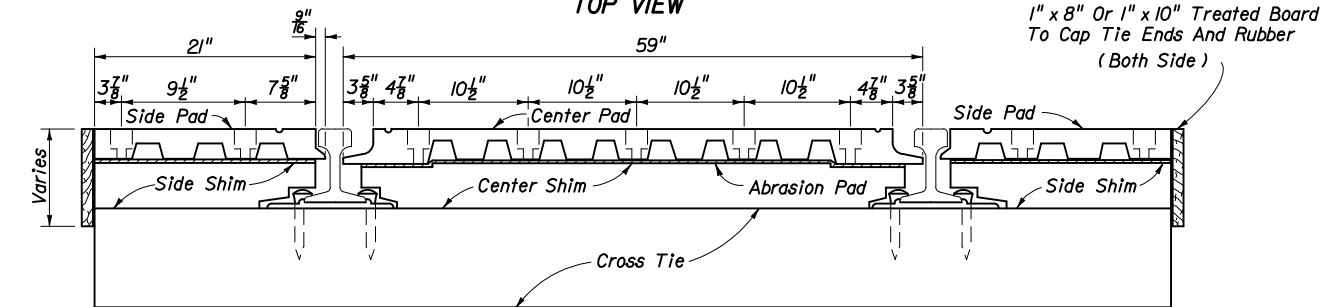

SECTION

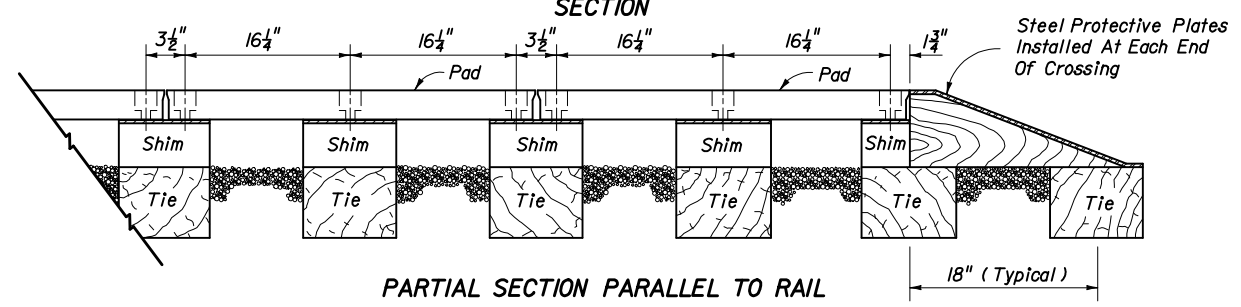

PARTIAL SECTION PARALLEL TO RAIL

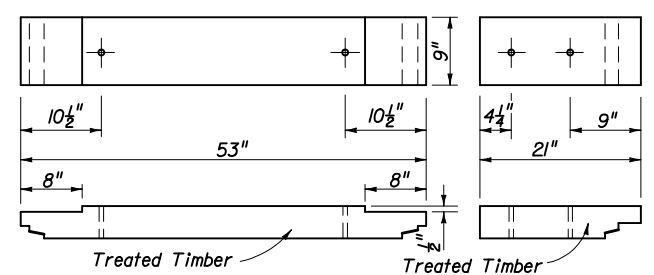

Shim Thickness Varies With Height Of Rail.

CENTER SHIM

SIDE SHIM

TYPE R

STOP ZONE	
Design Speed (mph)	Zone Length (Distance From Stop)
45 Or Less	250'
50 - 55	350'
60 - 65	500'
70	600'

NOTES

- The crossings shown on this sheet are NOT to be used for multiple track crossings within zones for an existing or scheduled future vehicular stop. Zone lengths are charted above.
- Crossings on this sheet may be used for single track crossings within the zones on the chart unless engineering or safety considerations dictate otherwise.
- Tie spacing is critical, ties shall be spaced in accordance with the manufacturers specifications.
- Details shown are for straight track installations. Materials are also available for curved track installations.
- For additional details, materials required and installation procedures refer to the manufacturers specifications.

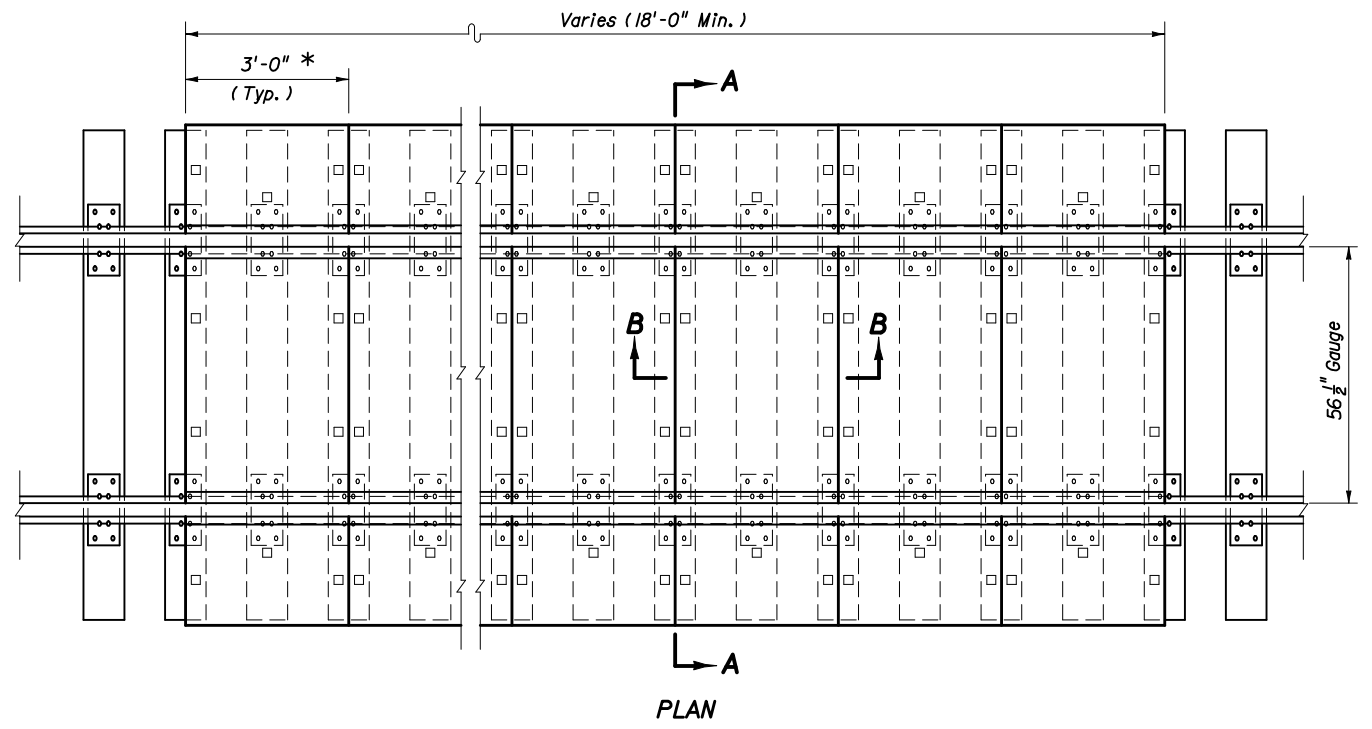

PLAN

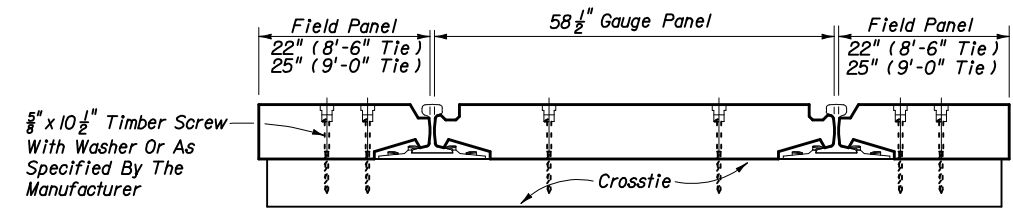

SECTION AA

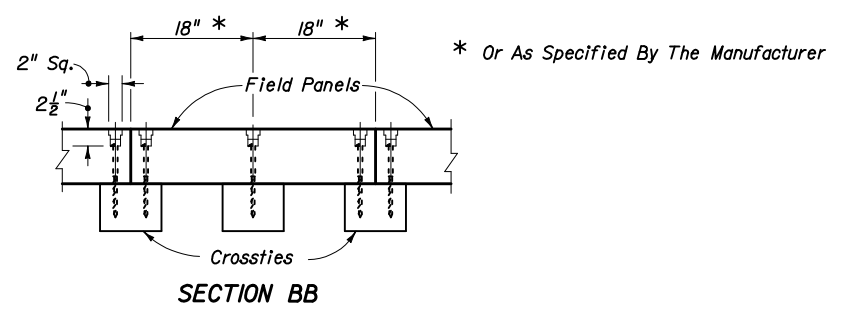

SECTION BB

HEAVY DUTY - FULL DEPTH RUBBER CROSSING
TYPE R FULL DEPTH

TYPES R RUBBER & R FULL DEPTH RUBBER

STATE OF FLORIDA DEPARTMENT OF TRANSPORTATION

RAILROAD CROSSINGS

Names	Dates	Approved By		
Designed By		 State Roadway Design Engineer		
Drawn By	LMP 11/75			
Checked By	GSB 11/75			
Revision	00			
		3 of 5	560	

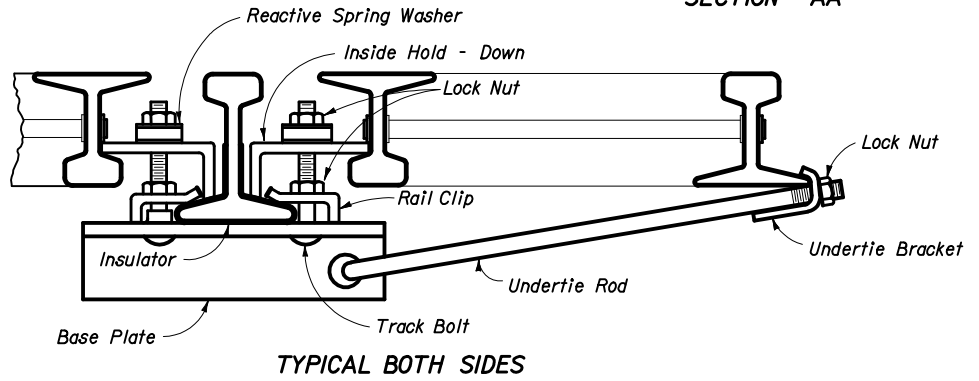
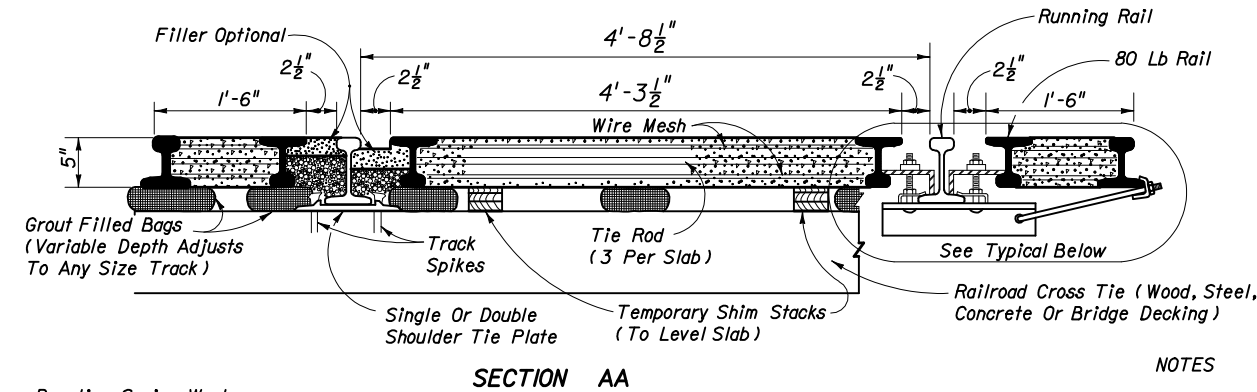
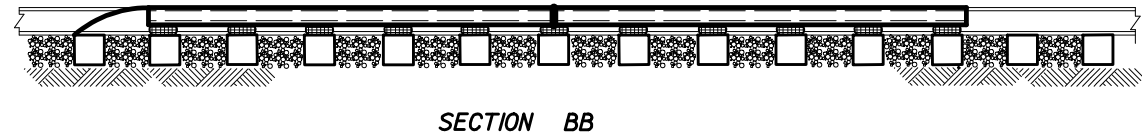
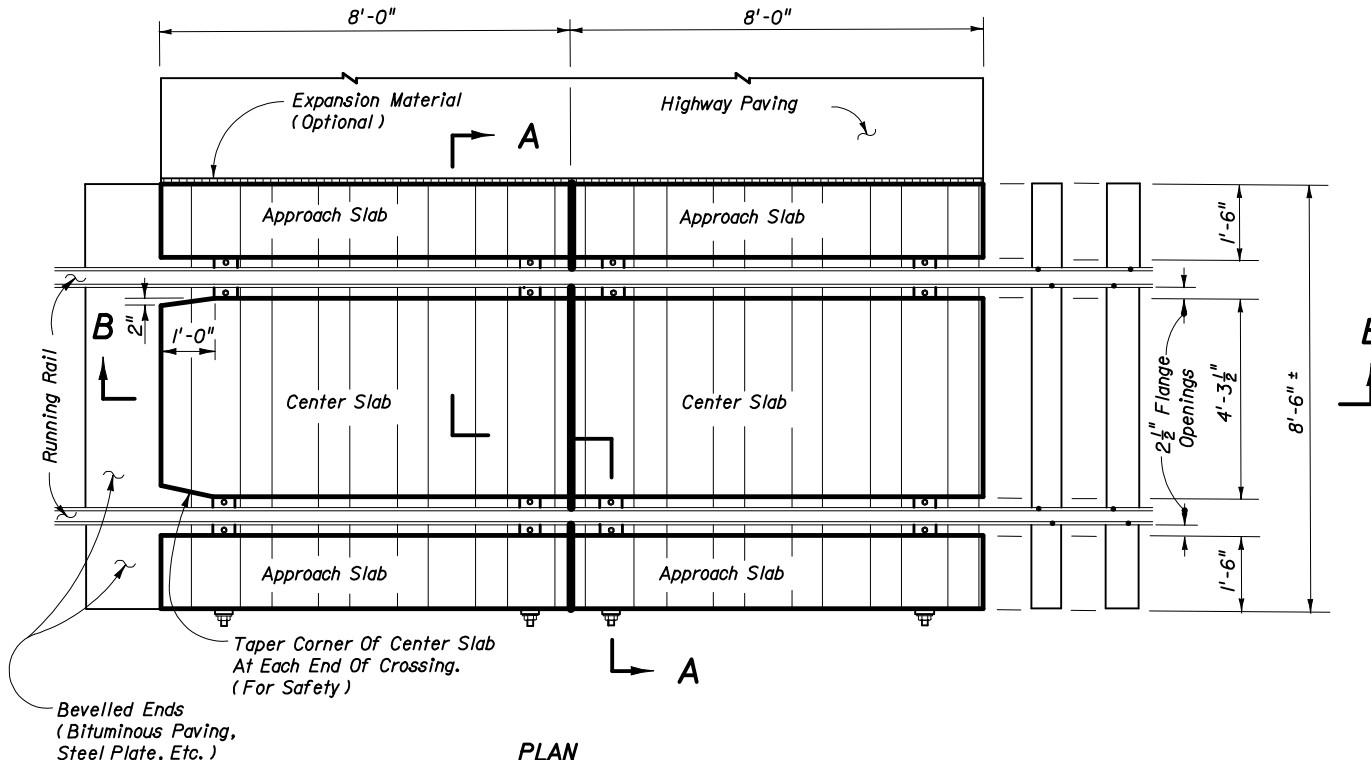

TYPE T

TYPES T & RS

- NOTES
1. The reinforced concrete slabs are manufactured in 8'-0" sections, 5" in depth to fit all rail sections 5 1/4" in height or heavier. Slabs are interchangeable and relocateable.
 2. Center slabs are one piece construction allowing for 2 1/2" flange opening, 80 lb. rail is used to encase, armor and reinforce slabs and is held to gage with 3 tie rods per slabs.
 3. Slabs are installed by a "flotation" process, supported on non-shrinkable, non-metallic grout positioned on the ties. Slabs can be placed on wood ties, concrete ties, steel ties, bridge decks or any other type of track support. No re-spacing of ties is necessary.
 4. Slabs are secured to "running rails" with specially designed hardware. Insulation is to be provided for crossing in signal territory.
 5. Curved slabs are fabricated to fit curved track to 22 degrees (262.04' radius). Special slabs are available for diamond crossings, turnouts, multiple tracks, bridge decks and rapid transit systems.
 6. For additional details, materials required and installation procedures refer to the manufacturers specifications.

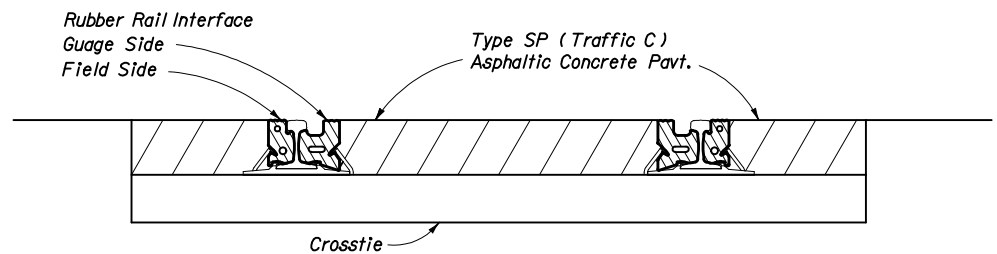

ALTERNATE INTERFACE SECTION VIEW

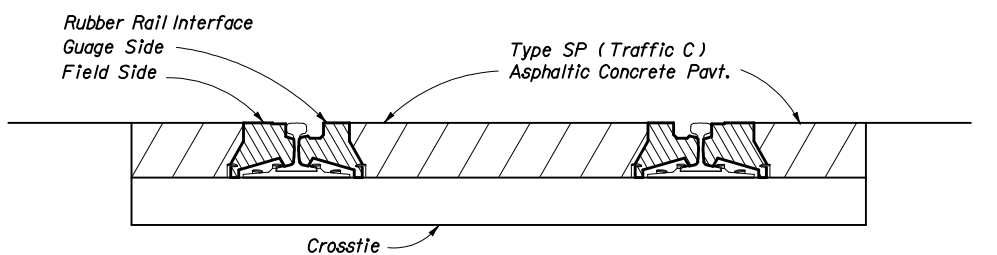

ALTERNATE INTERFACE SECTION VIEW

- NOTES
1. Rubber rail interface systems are manufactured to fit various rails from 115# to 136#.
 2. The Railroad Company will furnish and install all crossing material except as specified in the agreement.
 3. For additional details, methods required and installation procedures refer to the manufacturers specifications.

FULL DEPTH ASPHALT/RUBBER CROSSING TYPE RS

RAILROAD CROSSINGS				
Names	Dates	Approved By		
Designed By		 State Roadway Design Engineer		
Drawn By	IMP 02/77			
Checked By	GSB 02/77	Revision	Sheet No.	Index No.
		02	4 of 5	560

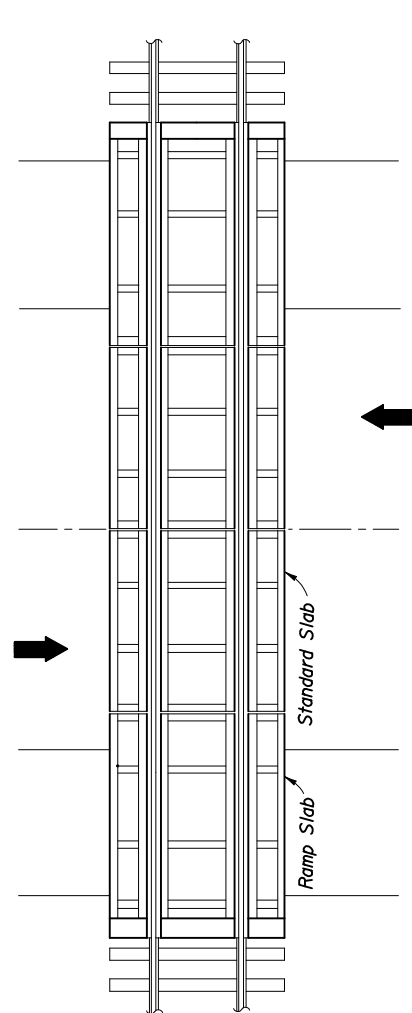

PLAN VIEW
TYPICAL 44' CROSSING

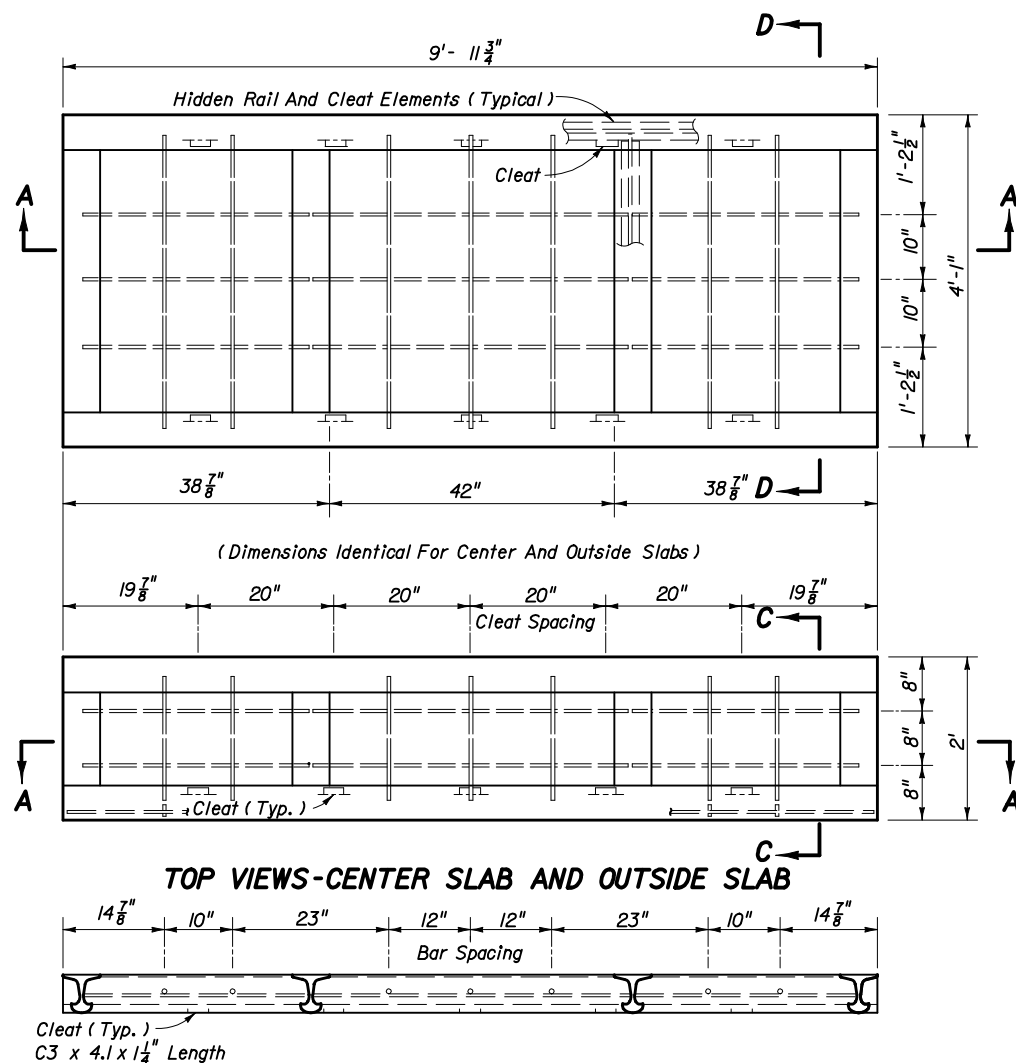

SECTION AA
STANDARD SLABS (PRECAST CONCRETE)

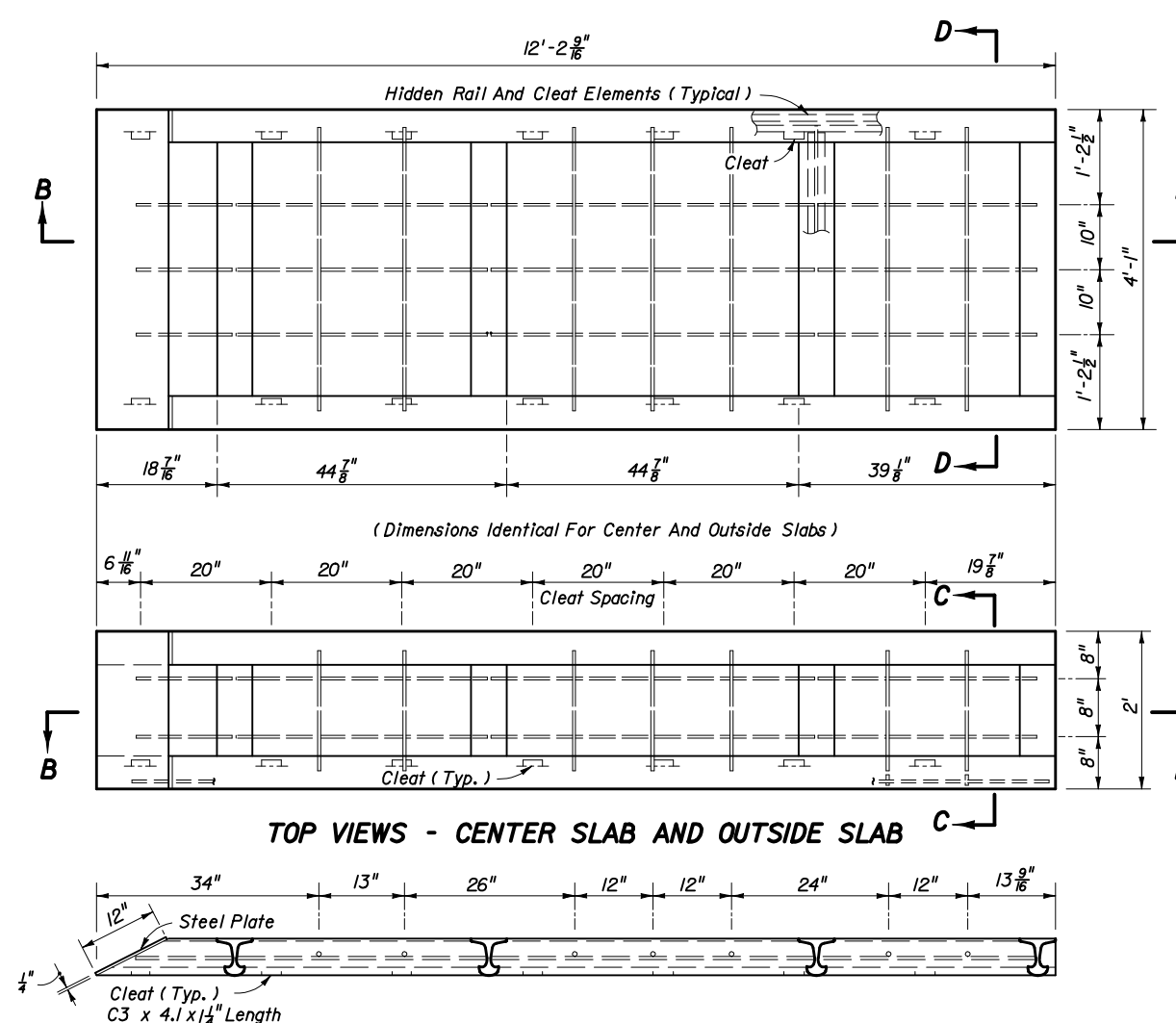

SECTION BB
RAMP SLABS (PRECAST CONCRETE)

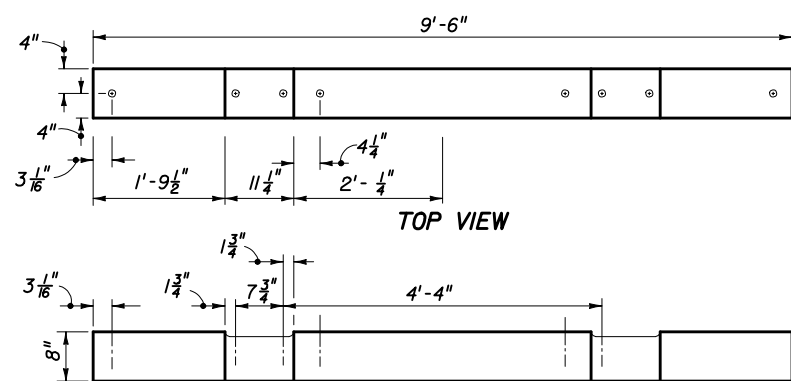

SIDE VIEW
PRECAST CONCRETE (CROSSING TIE)

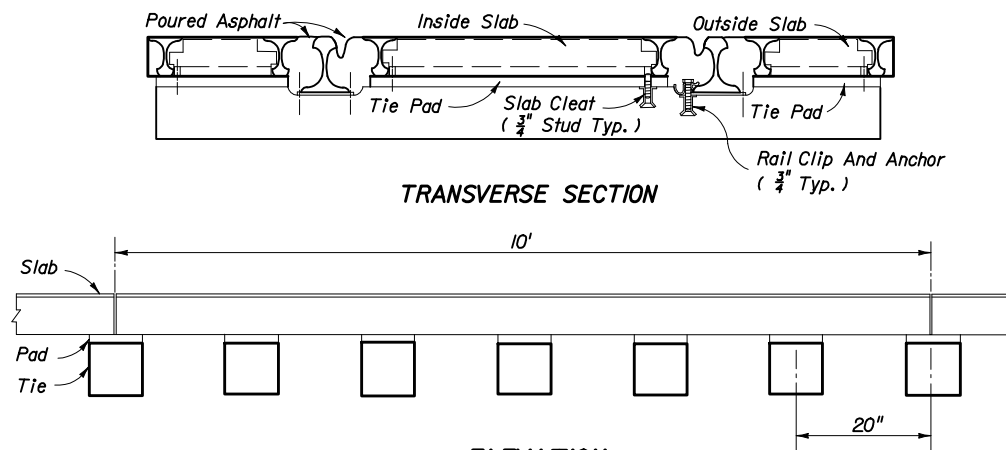

ELEVATION
TIE SPACING

TYPE T MODIFIED

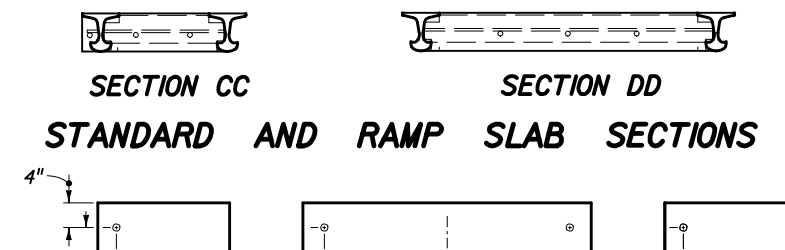

SECTION CC
SECTION DD
STANDARD AND RAMP SLAB SECTIONS



- NOTES
- Slab frames are welded 90 lb. rails.
 - Slab reinforcement all #4 bars.

STATE OF FLORIDA DEPARTMENT OF TRANSPORTATION				
RAILROAD CROSSING				
Designed By	Names	Dates	Approved By	
Drawn By	RWR	9/82	<i>Brian Blumhail</i> State Roadway Design Engineer	
Checked By	JVG/JBW	9/82	Revision	Sheet No.
			00	5 of 5
			Index No.	560