

SUPERELEVATION RATES (e) FOR URBAN HIGHWAYS AND HIGH SPEED URBAN STREETS

$e_{max} = 0.05$

TABULATED VALUES		CHARTED VALUES				
Degree Of Curve (D)	Radius (R) (Ft.)	Design Speed (mph)				
		30	35	40	45	50
2° 00'	2,865	NC	NC	NC	NC	NC
2° 15'	2,546					RC
2° 45'	2,083				NC	
3° 00'	1,910				RC	
3° 45'	1,528			NC		
4° 00'	1,432			RC		
4° 45'	1,206					RC
5° 00'	1,146		NC			0.023
5° 15'	1,091		RC			0.027
5° 30'	1,042					0.030
5° 45'	996					0.035
6° 00'	955				RC	0.040
6° 15'	917					0.022
6° 30'	881					0.024
6° 45'	849					0.027
7° 00'	819	NC				0.030
7° 15'	790	RC				0.033
7° 30'	764					0.037
7° 45'	739					0.041
8° 00'	716			RC		0.045
8° 15'	694					0.022
8° 30'	674					0.025
8° 45'	655					0.027
9° 00'	637					0.030
9° 30'	603					0.034
10° 00'	573					0.040
10° 30'	546		RC			0.047
11° 00'	521			0.023		Dmax. =
11° 30'	498			0.026		10° 45'
12° 00'	477			0.030		
13° 00'	441			0.036		
14° 00'	409	RC		0.045		
15° 00'	382	0.023		Dmax. =		
16° 00'	358	0.027		14° 15'		
17° 00'	337	0.032				
18° 00'	318	0.038				
19° 00'	302	0.043				
20° 00'	286	0.050				
		Dmax. =				
		20° 00'				

NC = Normal Crown
RC = Reverse Crown (+.02 Superelevation)

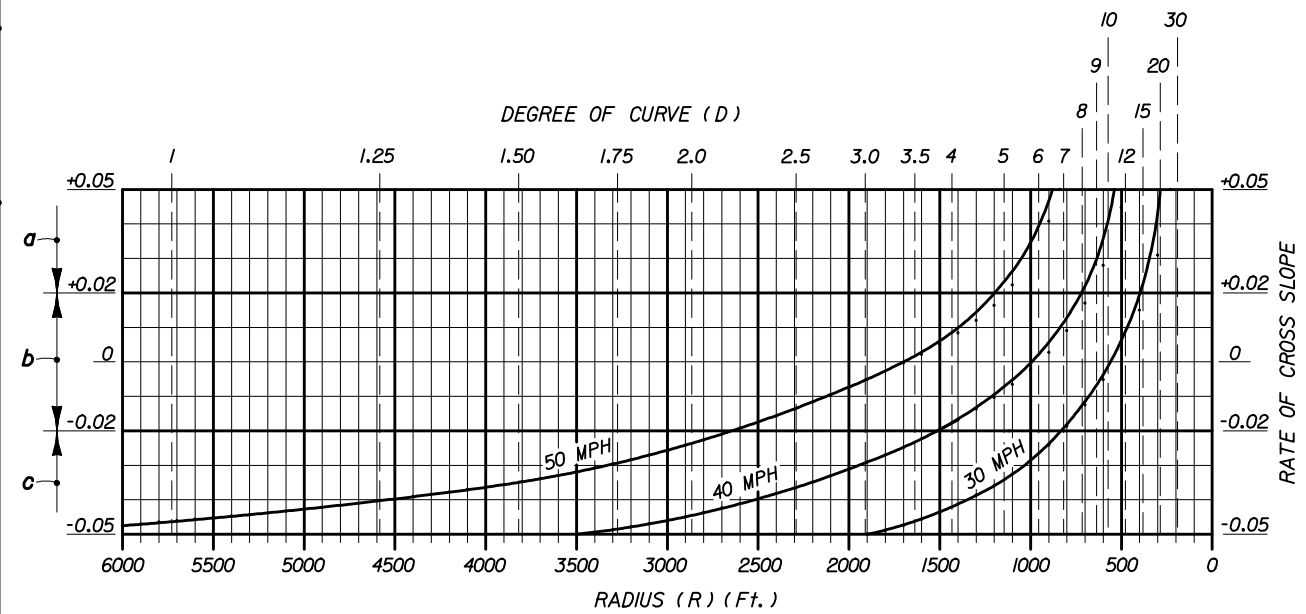

- a: When the speed curves and the degree of curve or radius lines intersect above this line, the pavement is to be superelevated (positive slope) at the rates indicated at the lines intersecting points.
- b: When the speed curves and the degree of curve or radius lines intersect between these limits, the pavement is to be superelevated at the rate of 0.02 (positive slope).
- c: When the speed curves and the degree of curve or radius lines intersect below this line, the pavement is to have normal crown (typically 0.02 and 0.03 downward slopes).

GENERAL NOTES

1. Maximum rate of superelevation for urban highways and high speed urban streets shall be 0.05.
2. Superelevation shall be obtained by rotating the plane successively about the break points of the section until the plane has attained a slope equal to that required by the chart. Should the rotation traverse the entire section and further superelevation be required, the remaining rotation of the plane shall be about the low edge of the inside travel lane.
Crown is to be removed in the auxiliary lane to the outside of the curve only when the adjoining travel lanes require positive superelevation.
3. When positive superelevation is required, the slope of the gutter on the high side shall be a continuation of the slope of the superelevated pavement.
4. In construction, short vertical curves shall be placed at all angular profile breaks within the limits of the superelevation transition.
5. The variable superelevation transition length "L" shall have a minimum value of 50 feet for design speeds under 40 MPH and 75 feet for design speeds of 40 MPH or greater.
6. Roadway sections having lane arrangements different from those shown, but composed of a series of planes, shall be superelevated in a similar manner.
7. For superelevation of lower speed urban streets, see the FDOT 'Manual Of Uniform Minimum Standards For Design, Construction And Maintenance For Streets And Highways'. For superelevation of curves on rural highways, urban freeways and high speed urban highways, see Index No. 510.

$e_{max} = 0.05$

SUPERELEVATION FOR URBAN HIGHWAYS AND HIGH SPEED URBAN STREETS

STATE OF FLORIDA DEPARTMENT OF TRANSPORTATION				
SUPERELEVATION				
URBAN HIGHWAYS AND STREETS				
Names	Dates	Approved By		
Designed By	WLB/JVG 66 & 90	State Roadway Design Engineer		
Drawn By	CDR/HSD 67 & 90	Revision	Sheet No.	Index No.
Checked By	RLD/JVG 67 & 90	00	1 of 3	511

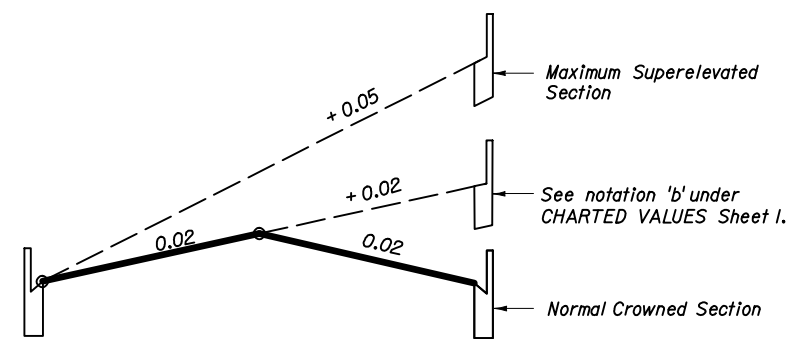

TWO TRAVEL LANES EACH DIRECTION

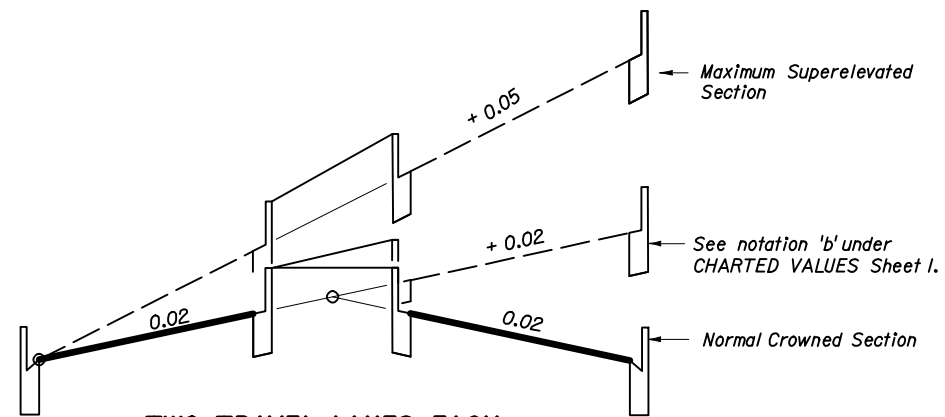

TWO TRAVEL LANES EACH DIRECTION WITH MEDIAN

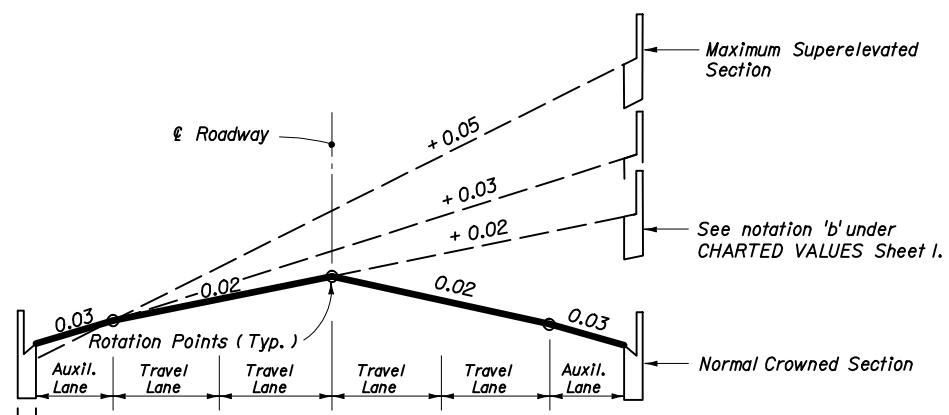

TWO TRAVEL LANES EACH DIRECTION WITH AUXILIARY LANES

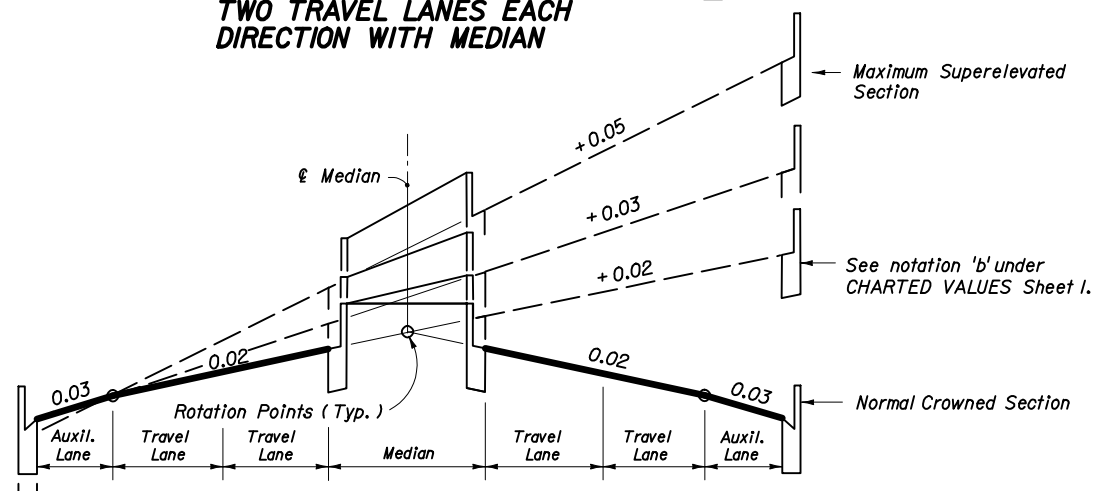

TWO TRAVEL LANES EACH DIRECTION WITH MEDIAN AND AUXILIARY LANES

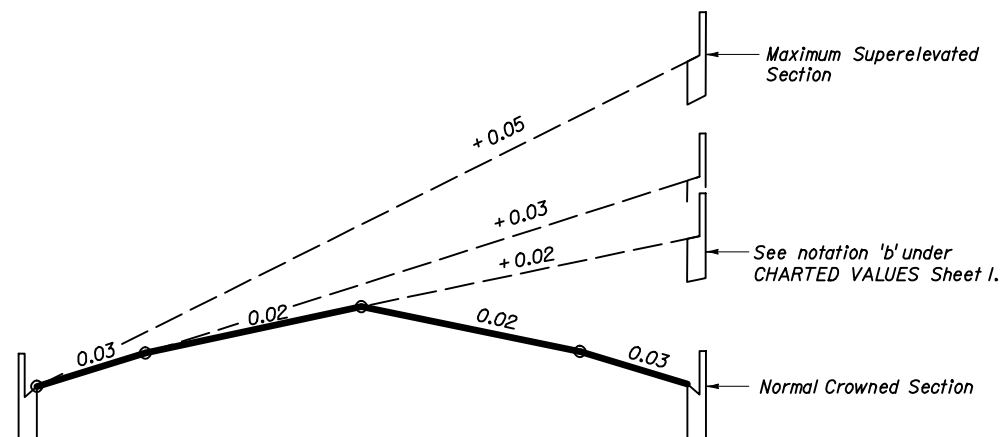

THREE TRAVEL LANES EACH DIRECTION

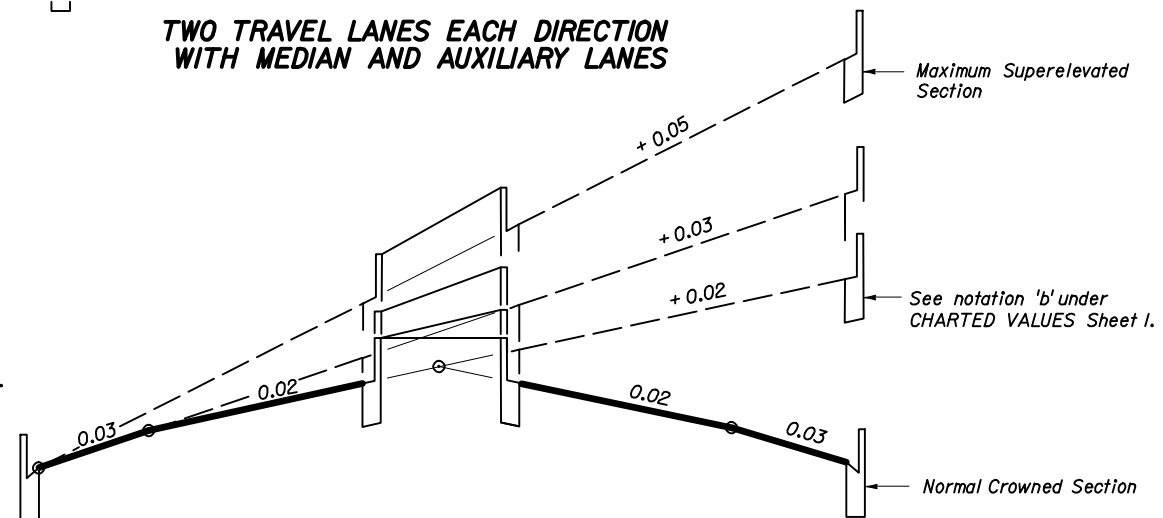

THREE TRAVEL LANES EACH DIRECTION WITH MEDIAN

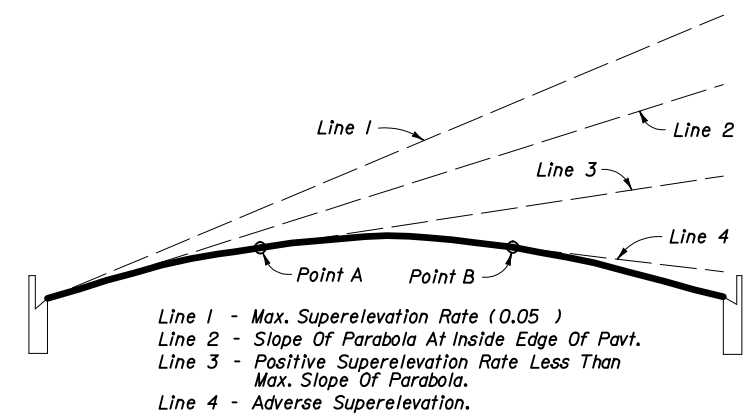

Line 1 - Max. Superelevation Rate (0.05)
 Line 2 - Slope Of Parabola At Inside Edge Of Pavt.
 Line 3 - Positive Superelevation Rate Less Than Max. Slope Of Parabola.
 Line 4 - Adverse Superelevation.

Superelevation rates obtained from the chart or table on Sheet I are also applicable to a parabolic crown section. When this section is used, superelevation is established by rotating a tangent about the arc of the parabolic crown until the desired slope is attained (points A & B on sketch). The normal parabolic crown will be maintained outside the limits of the plane thus formed.

PARABOLIC SECTION

UNDIVIDED FACILITIES

DIVIDED FACILITIES

SUPERELEVATION TRANSITION SECTIONS FOR URBAN HIGHWAYS AND HIGH SPEED URBAN STREETS

STATE OF FLORIDA DEPARTMENT OF TRANSPORTATION				
SUPERELEVATION				
URBAN HIGHWAYS AND STREETS				
Names	Dates	Approved By		
Designed By	WLB/JVG	66/90	 State Roadway Design Engineer	
Drawn By	CDR/HSD	67/90		
Checked By	RLO/JVG	67/90		
Revision	00	Sheet No.		
		2 of 3	511	

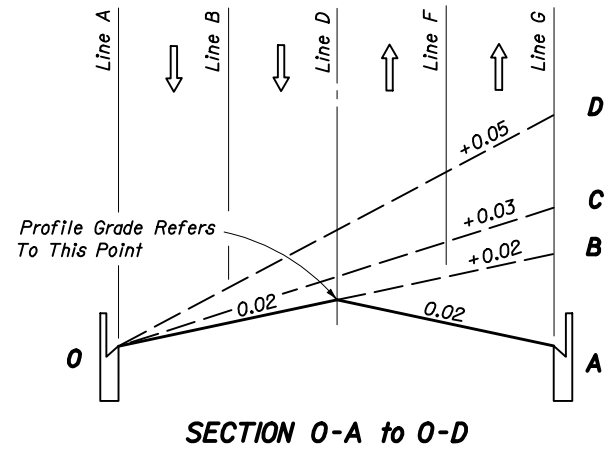

SECTION 0-A to 0-D

TWO LANES EACH DIRECTION

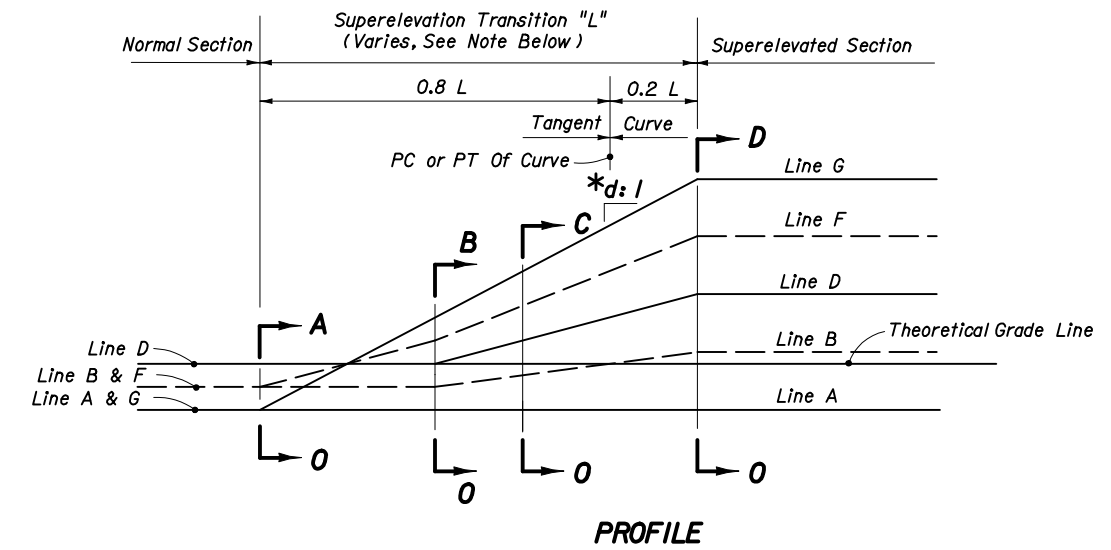

PROFILE

LINE	DESCRIPTION
A	Inside Travel Lane
B	Inside Lane Line
C	Inside Median Edge Pavement
D	℄ Construction
E	Outside Median Edge Pavement
F	Outside Lane Line
G	Outside Travel Lane

Inside And Outside Are Relative To Curve Center

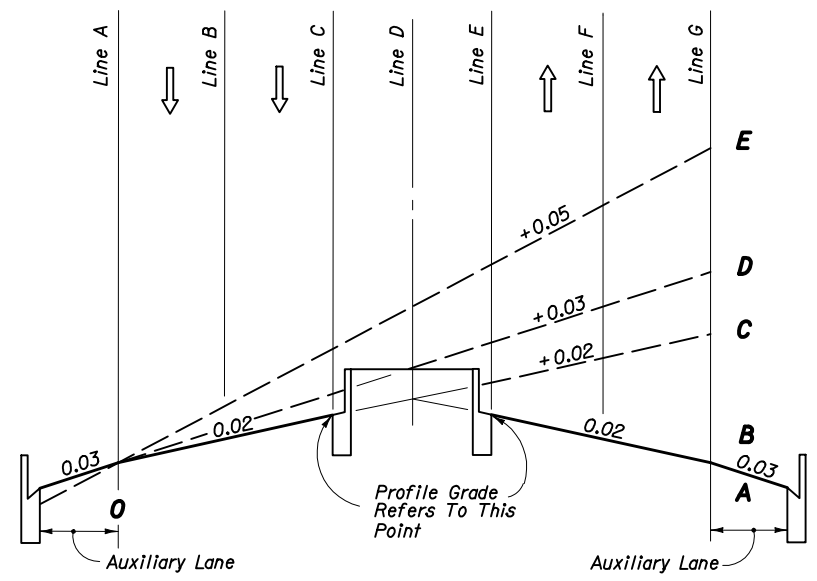

SECTION 0-A to 0-E

TWO LANES EACH DIRECTION WITH MEDIAN AND AUXILIARY LANE

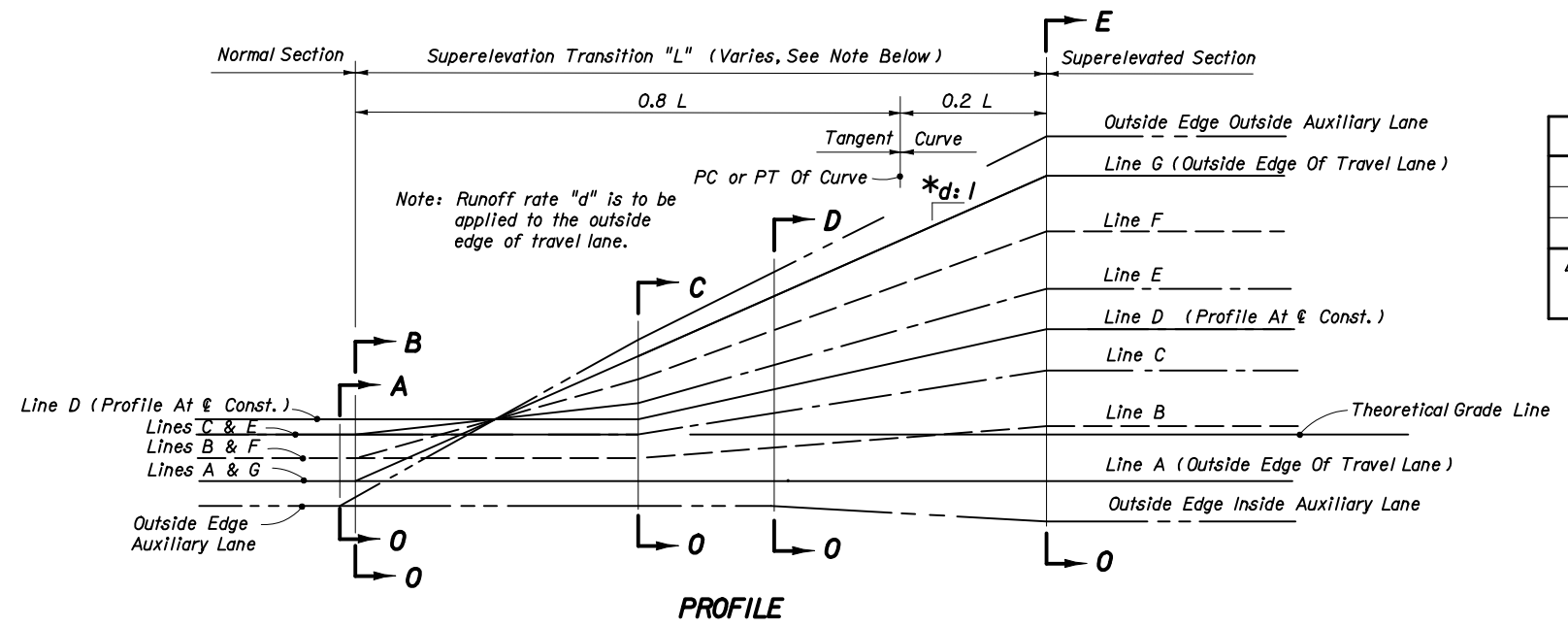

PROFILE

*d (Slope Ratio)	
30 MPH	1: 100
40 MPH	1: 125
45-50 MPH Δ	1: 150

Δ 1:125 May Be Used For 45 MPH Under Restricted Conditions.

Note: The sections and profiles shown are examples of superelevation transitions. Similar schemes should be used for roadways having other sections.

EXAMPLE SUPERELEVATION SECTIONS AND PROFILES FOR URBAN HIGHWAYS AND HIGH SPEED URBAN STREETS

STATE OF FLORIDA DEPARTMENT OF TRANSPORTATION

SUPERELEVATION
URBAN HIGHWAYS AND STREETS

Names	Dates	Approved By
Designed By: WLB/JVG	66/90	<i>Blair Blackwell</i> State Roadway Design Engineer
Drawn By: CDR/HSD	67/90	
Checked By: RLO/JVG	67/90	
Revision	00	
Sheet No.	3 of 3	Index No.
		511