

□ Crosswalk widths and configuration vary; must conform to Index No. 17344 and 17346.

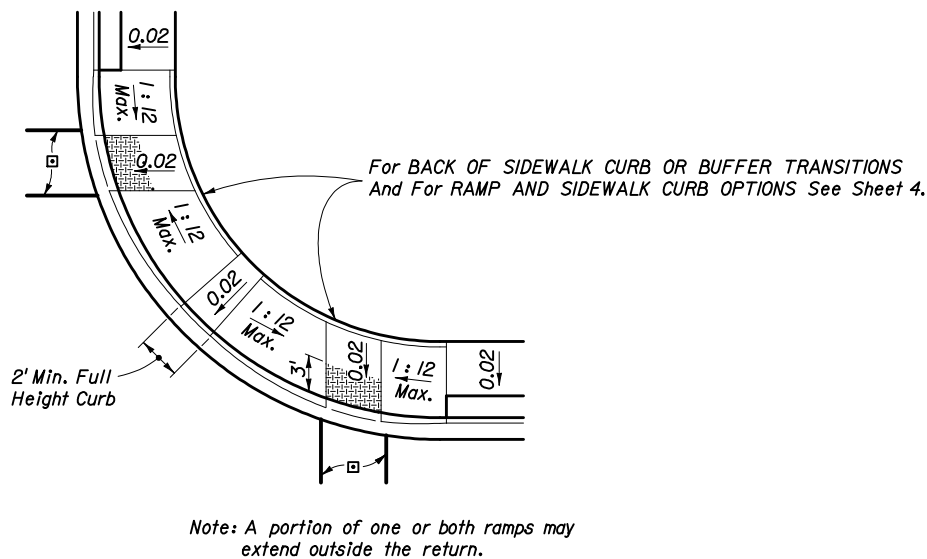

TYPICAL PLACEMENT OF PUBLIC SIDEWALK CURB RAMPS AT CURBED RETURNS

GENERAL NOTES

1. Public sidewalk curb ramps shall be constructed in the public right of way at locations that will provide continuous unobstructed pedestrian circulation paths to pedestrian areas, elements and facilities in the public right of way and to accessible pedestrian routes on adjacent sites. Curbed facilities with sidewalks and those without sidewalks are to have curb ramps constructed at all street intersections and at turnouts that have curbed returns. Partial curb returns shall extend to the limit prescribed by Index No. 515 to accommodate curb ramps. Ramps constructed at locations without sidewalks shall have a landing constructed at the top of each ramp, see Sheet 5.

2. The location and orientation of curb ramps shall be as shown in the plans.

3. Curb ramp running slopes at unrestrained sites shall not be steeper than 1:12 and cross slope shall be 0.02 or flatter. Transition slopes shall not be steeper than 1:12. Where curb ramps are located on roadway grades steeper than 0.02 and the accompanying sidewalk has a concurrent grade, the transverse slope of connecting perpendicular ramps, combined crossing ramps and interior block ramps.

When altering existing pedestrian facilities where existing site development precludes the accommodation of a ramp slope of 1:12, a running slope between 1:12 and 1:10 is permitted for a rise of 6" maximum and a running slope of between 1:10 and 1:8 is permitted for a rise of 3" maximum. Where compliance with the requirements for cross slope cannot be fully met, the minimum feasible cross slope shall be provided.

Ramp running slope is not required to exceed 8' in length, except at sites where the plans specify a greater length.

4. If a curb ramp is located where pedestrians must walk across the ramp, then the walk shall have transition slopes to the ramp; the maximum slope of the transitions shall be 1:12. Ramps with curb returns may be used at locations where other improvements provide guidance away from that portion of curb perpendicular to the sidewalk; improvements for guidance are not required at curb ramps for linear pedestrian traffic.

5. When perpendicular curb ramps abut the back of curb a tactile surface shall be applied to the full width and length of the ramp. When landings of parallel curb ramps abut the back of curb the tactile surface shall extend full width and 3' back of the curb. The tactile surfaces on curb ramps for linear pedestrian traffic and for corner ramps under conditions of infeasibility are to conform with the details in this Index for those specific ramp types. Tactile surfaces shall be constructed by texturing to a depth not less than 1/8" and not exceeding 1/4" by use of a tamp or roller fabricated with an imprinting surface of either 1" mesh 1/4" wire cloth (plain weave, conventional crimp) #6 expanded metal (standard) or 3 lb. expanded metal grating. Transition slopes are not to have tactile surfaces. Detectable surface requirements have been suspended; if reinstated the detectable surface requirements will replace the tactile surface requirements and notice will be by special provision.

6. Where a curb ramp is constructed within existing curb, curb and gutter and/or sidewalk, the existing curb or curb and gutter shall be removed to the nearest joint beyond the curb transitions or to the extent that no remaining section of curb or curb and gutter is less than 5' long. The existing sidewalk shall be removed to the nearest joint beyond the transition slope or walk around or to the extent that no remaining section of sidewalk is less than 5' long.

7. Alpha-numeric identifications are for reference (plans, permits, etc.).

8. Public sidewalk curb ramps are to be paid for as follows:
Ramps, reconstructed sidewalks, walk around sidewalks, sidewalk landings and sidewalk curbs are to be paid for under the contract unit price for Sidewalk Concrete, (___" Thick), SY. Curb transitions and reconstructed curbs are to be paid for under the contract unit price for the parent curb, i.e., Curb Conc., (Type ___), LF or Curb and Gutter Conc., (Type ___), LF.

When a separate pay item for the removal and disposal of existing curb, curb and gutter, and/or sidewalk is not provided in the plans, the cost of removal and disposal of these features shall be included in the contract unit price for new curb, curb and gutter and/or sidewalk respectively.

STATE OF FLORIDA DEPARTMENT OF TRANSPORTATION				
PUBLIC SIDEWALK CURB RAMPS				
Names	Dates	Approved By		
Designed By	STAFF	10/94	 State Roadway Design Engineer	
Drawn By	HKH	10/94		
Checked By	JVG	10/94	Revision	Sheet No.
			02	1 of 5
				Index No.
				304

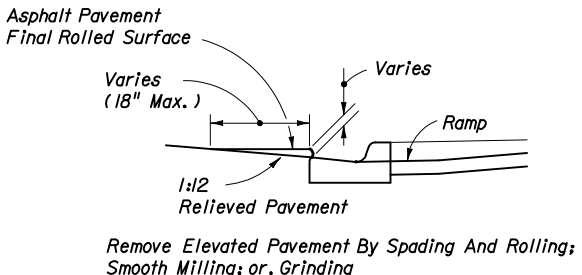
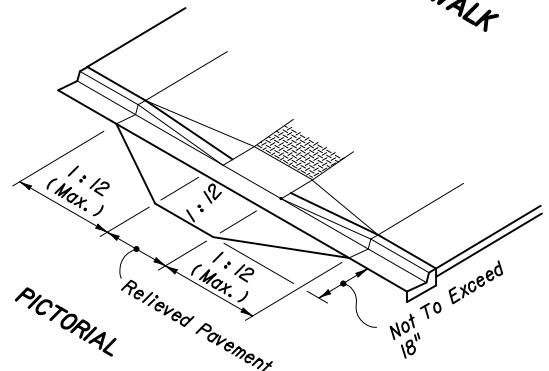
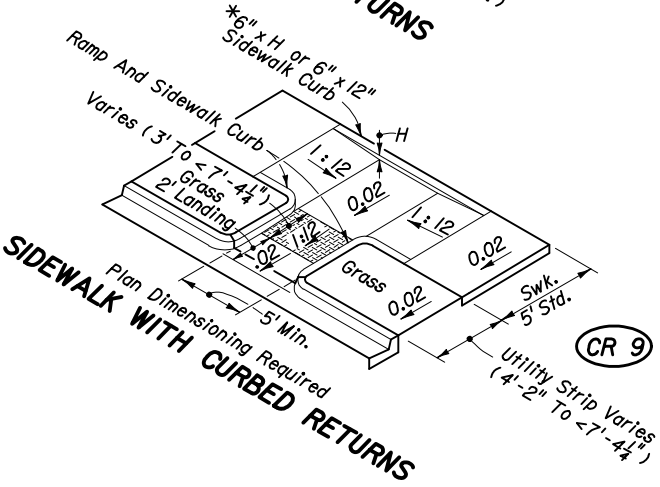
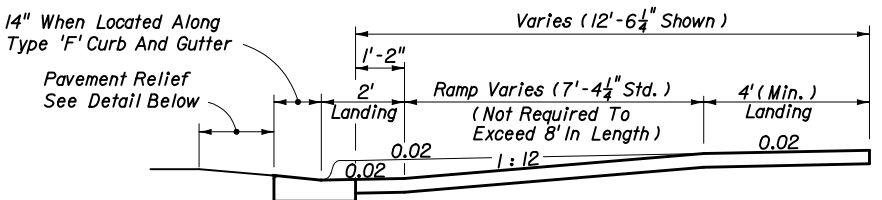
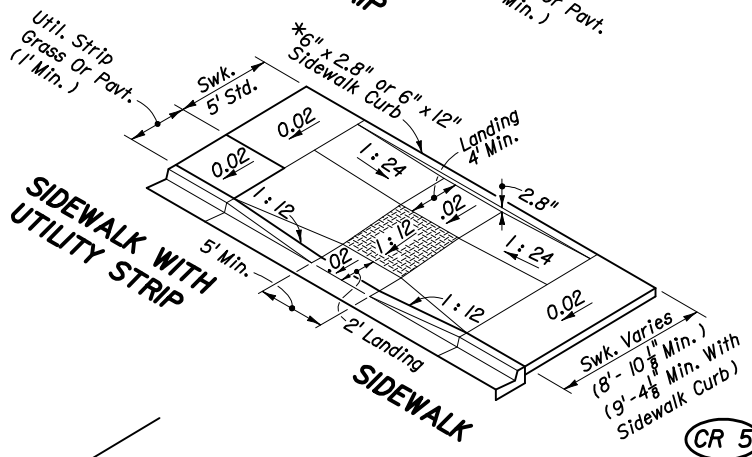
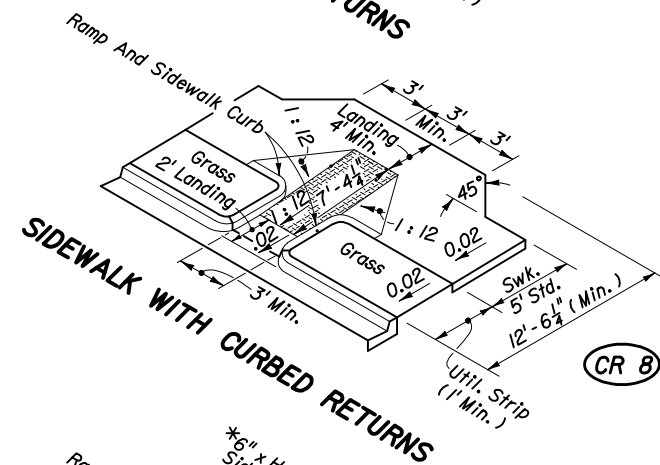
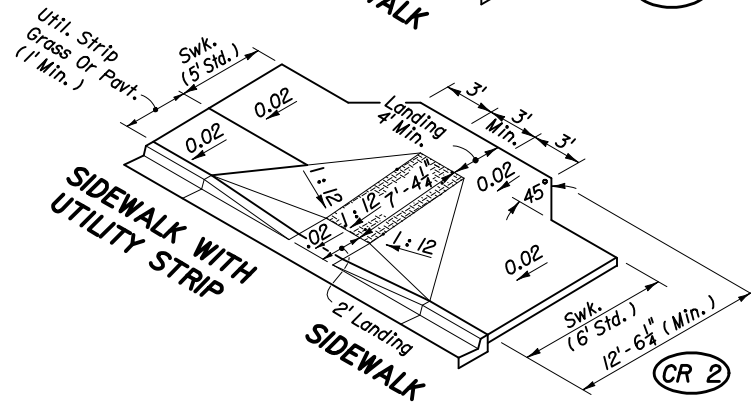
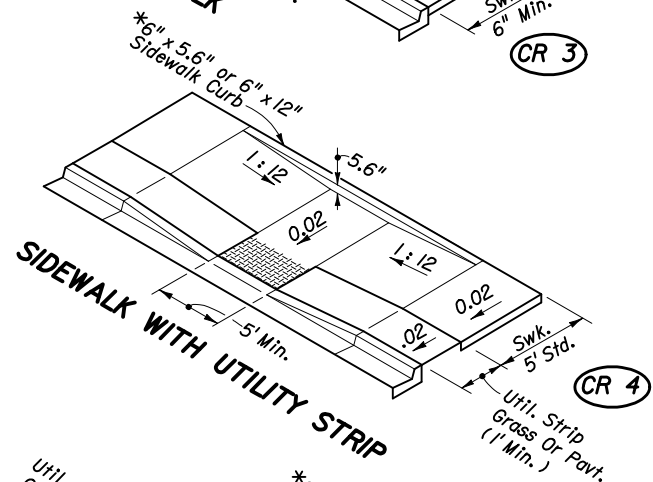
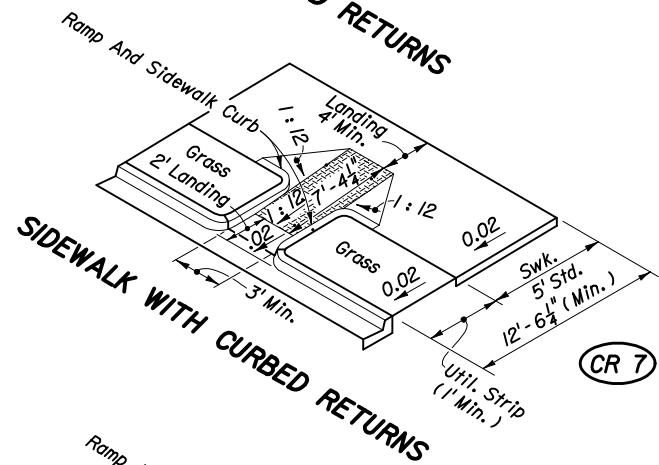
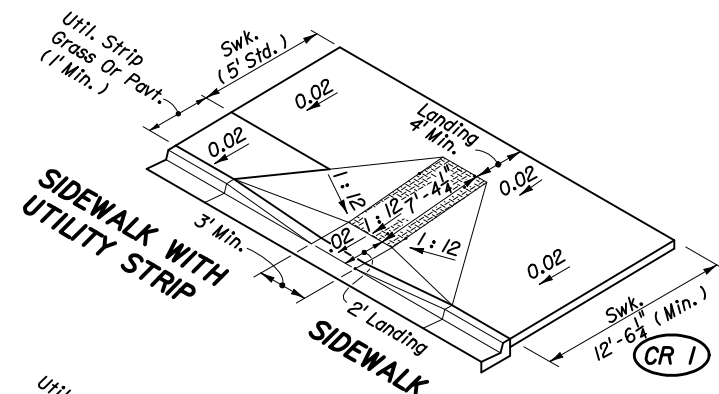
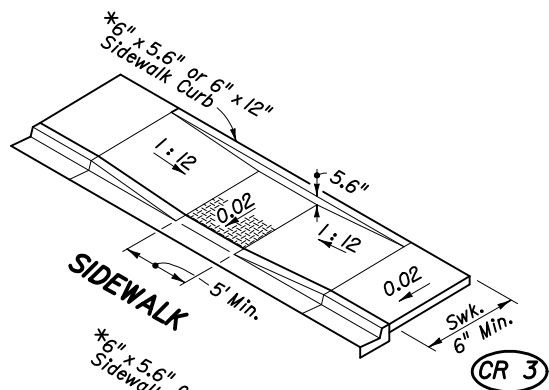
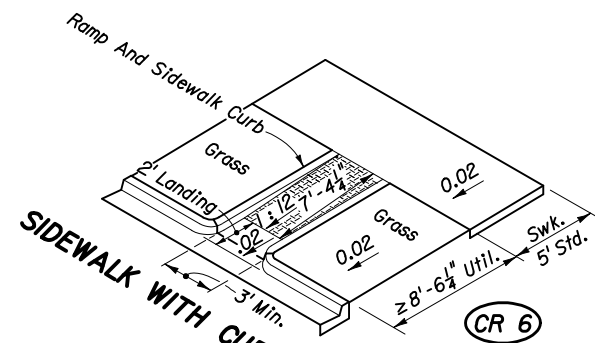

PAVEMENT RELIEF AT LIP OF CURB

* For BACK OF SIDEWALK CURB OR BUFFER TRANSITION And For RAMP AND SIDEWALK CURB OPTIONS See Sheet 4.

DIMENSIONAL FEATURES FOR PUBLIC SIDEWALK CURB RAMPS WHERE RAMP AND LANDING DEPTH ARE NOT RESTRICTED BY RIGHT OF WAY

STATE OF FLORIDA DEPARTMENT OF TRANSPORTATION				
PUBLIC SIDEWALK CURB RAMPS				
Names	Dates	Approved By		
Designed By	STAFF	10/94	 State Roadway Design Engineer	
Drawn By	HKH	10/94		
Checked By	JVG	10/94		
Revision	02	Sheet No.		
Index No.	304			

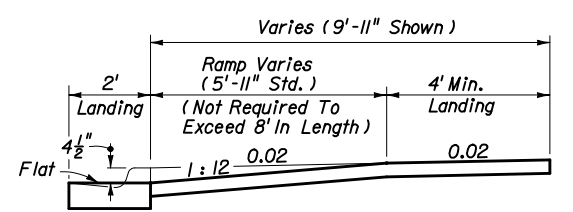
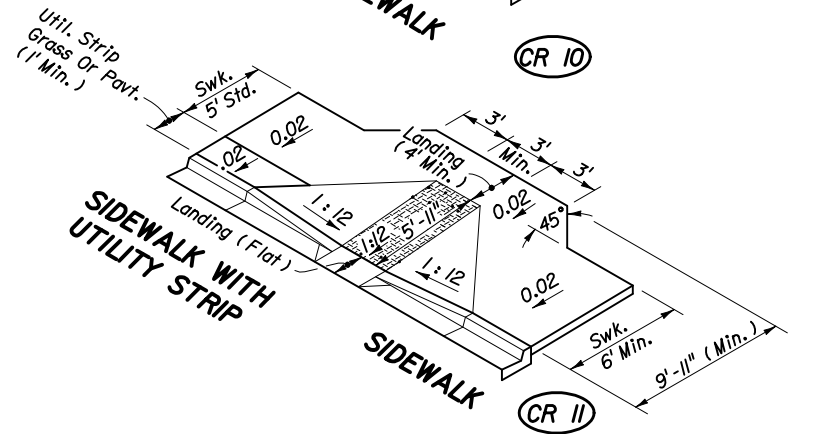
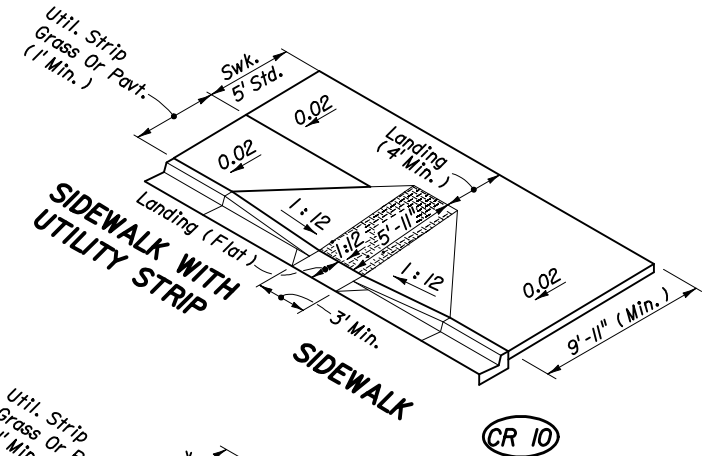
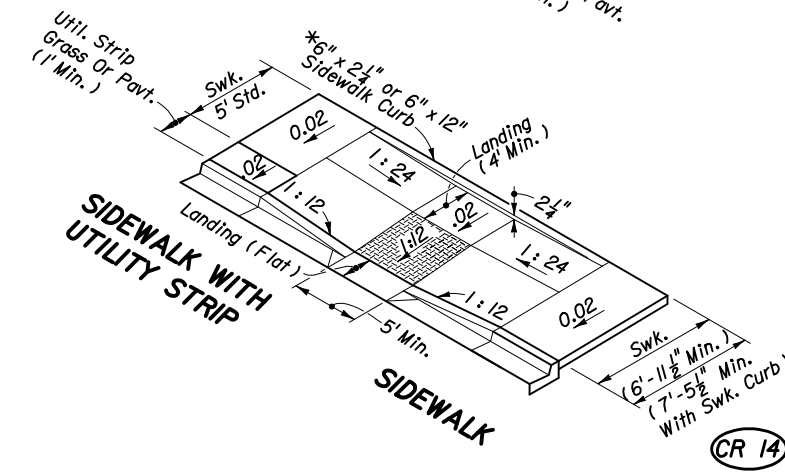
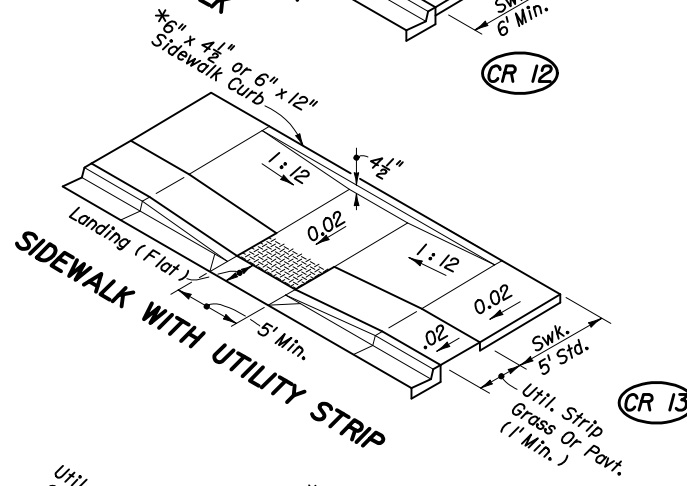
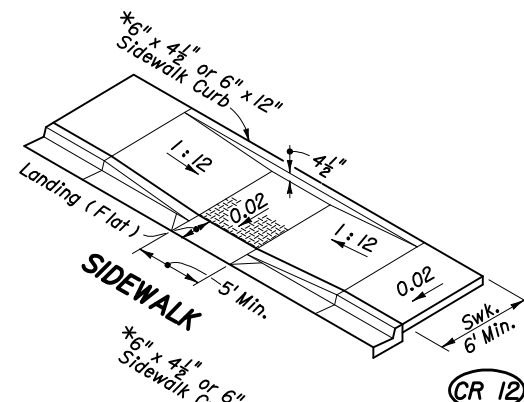
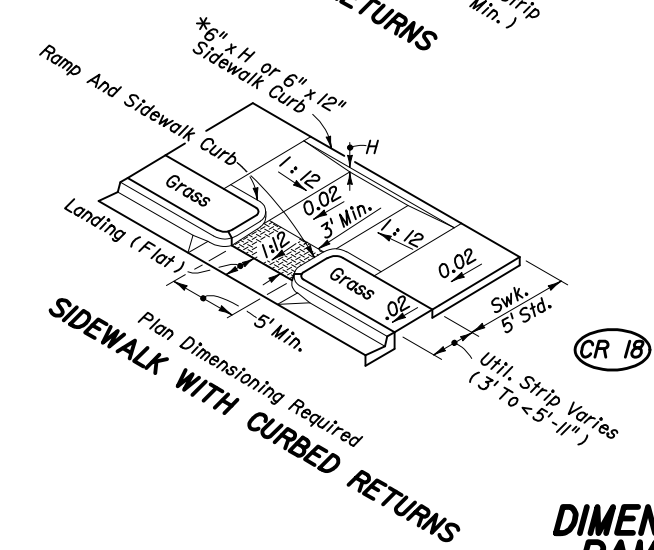
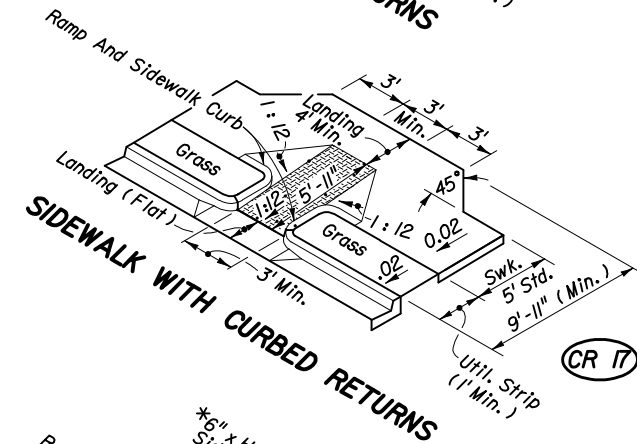
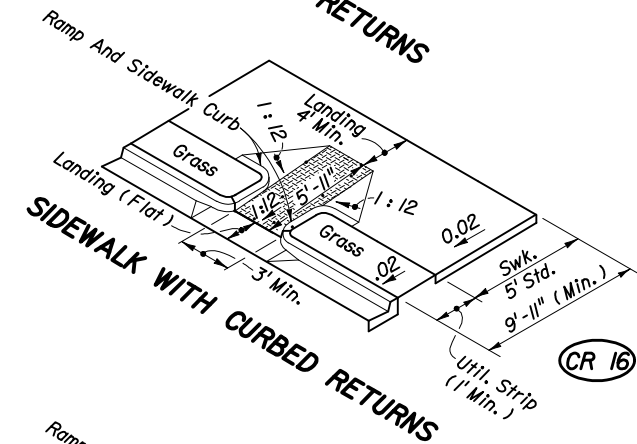
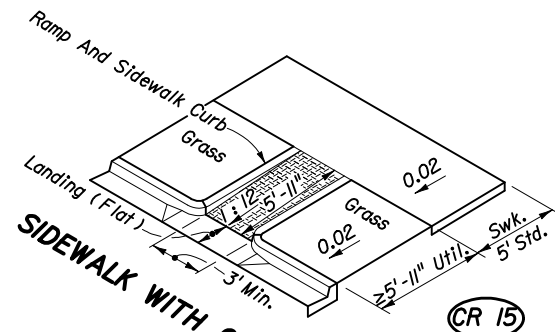

SECTION THROUGH RAMP RUN AND LANDINGS WITH UPPER LANDING AT NORMAL SIDEWALK ELEVATION

* For BACK OF SIDEWALK CURB OR BUFFER TRANSITION And For RAMP AND SIDEWALK CURB OPTIONS See Sheet 4.

DIMENSIONAL FEATURES FOR PUBLIC SIDEWALK CURB RAMPS WHERE RAMP AND LANDING DEPTH ARE RESTRICTED BY RIGHT OF WAY

STATE OF FLORIDA DEPARTMENT OF TRANSPORTATION

PUBLIC SIDEWALK CURB RAMPS

Names	Dates	Approved By		
Designed By	STAFF	10/94	 State Roadway Design Engineer	
Drawn By	HKH	10/94		
Checked By	JVG	10/94		
Revision	00	Sheet No.		
		3 of 5	304	

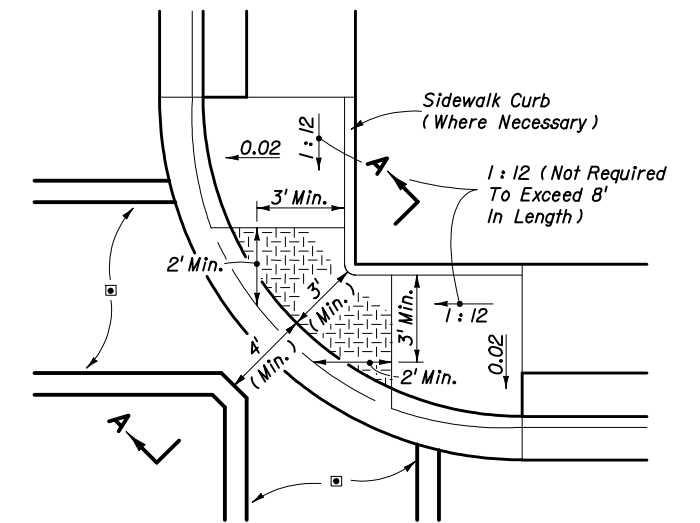
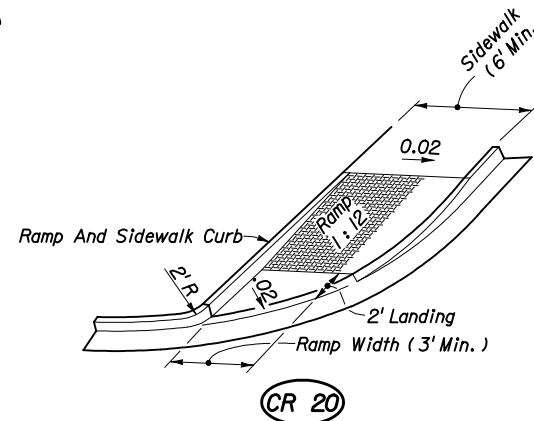
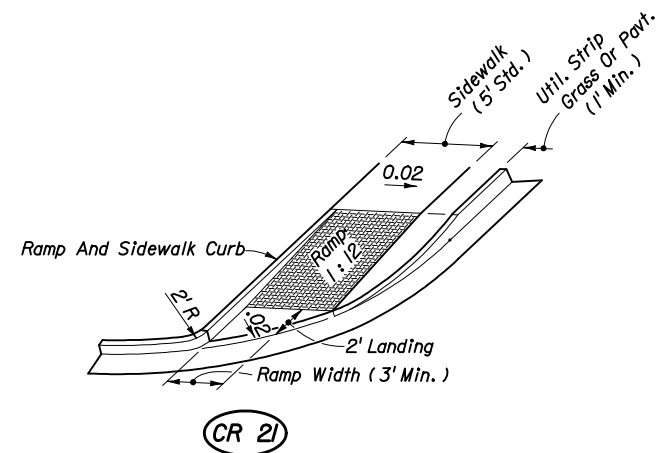
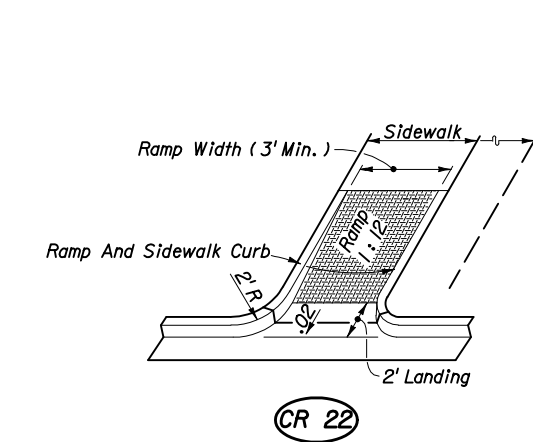
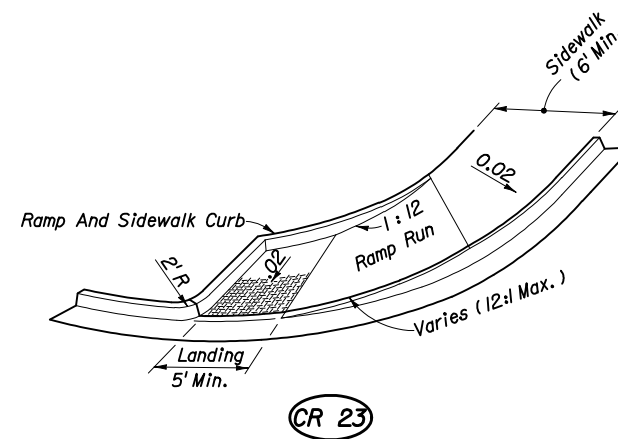
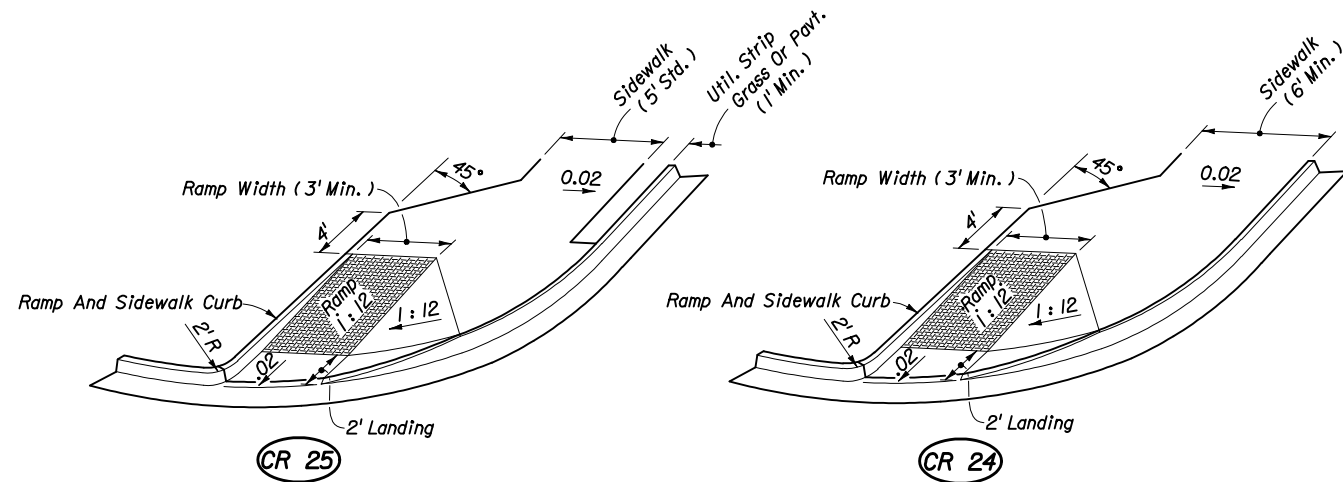

□ Crosswalk width and configuration vary; must conform to Index No. I7344 and I7346.

PLAN

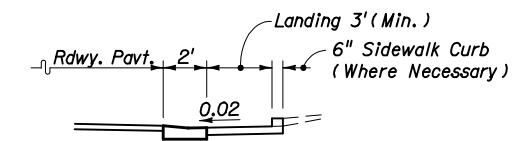

SECTION AA

CR 26

DIMENSIONAL FEATURES FOR PUBLIC SIDEWALK CURB RAMPS FOR LINEAR PEDESTRIAN TRAFFIC

DIMENSIONAL FEATURES FOR PUBLIC SIDEWALK COMBINED CORNER RAMPS UNDER CONDITIONS OF INFEASIBILITY

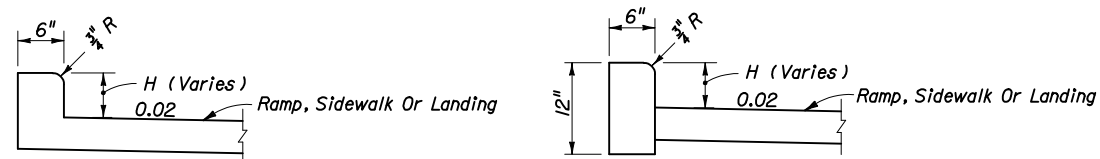

MONOLITHIC CAST CURB

SEPARATELY CAST CURB

RAMP AND SIDEWALK CURB OPTIONS

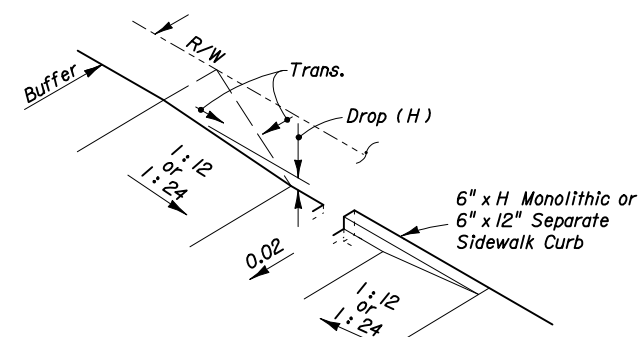

Construct Sidewalk Curb In Absence Of Adequate Buffer, Maintainable Surface Contour, Abutting Structure, Or When Called For In The Plans Or Standards

BACK OF SIDEWALK CURB OR BUFFER TRANSITION

STATE OF FLORIDA DEPARTMENT OF TRANSPORTATION				
PUBLIC SIDEWALK CURB RAMPS				
Names	Dates	Approved By		
Designed By	STAFF	10/94	 State Roadway Design Engineer	
Drawn By	HKH	10/94		
Checked By	JVG	10/94		
Revision	00	Sheet No.		
			Index No.	304

5' Refuge With Maximum Slope Of 0.02 Must Be Provided When Slopes Of 0.05 Or Flatter And 5' In Length Are Not Available On Crosswalk; The Refuge Can Be Constructed At Any Location Within The Crosswalk; Or, A 5' x 5' Concrete Landing With Maximum Slope Of 0.02 Can Be Constructed Adjacent To The Crosswalk.

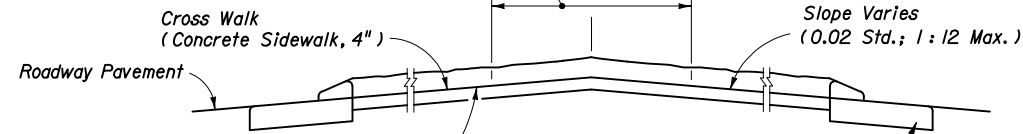

Slopes Shall Intersect At Centerline Of Median On The 0.02 Rate When The Edge Of Pavement Elevations Are Equal. The Slopes May Intersect Off The Centerline For Variable Edge Of Pavement Elevations Or To Accommodate Other Construction In The Median; However, Slopes Shall Not Be Steeper Than 1:12.

SECTION CC

MEDIAN CROSSWALKS

Curb Transition (On Existing Facilities Remove And Reconstruct Curb Or Curb And Gutter) For Payment See General Note 8.

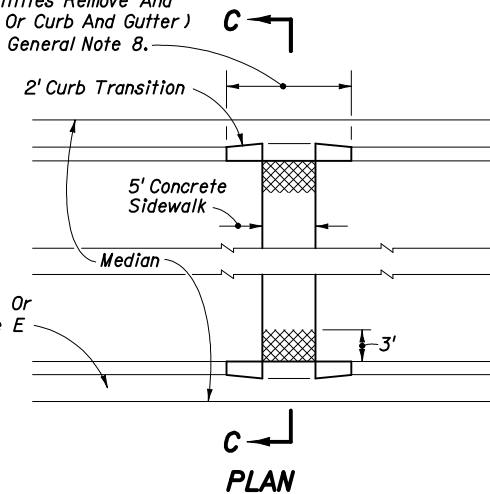

Curb Types A Or B Or Curb & Gutter Type E (Curb And Gutter Type E Shown)

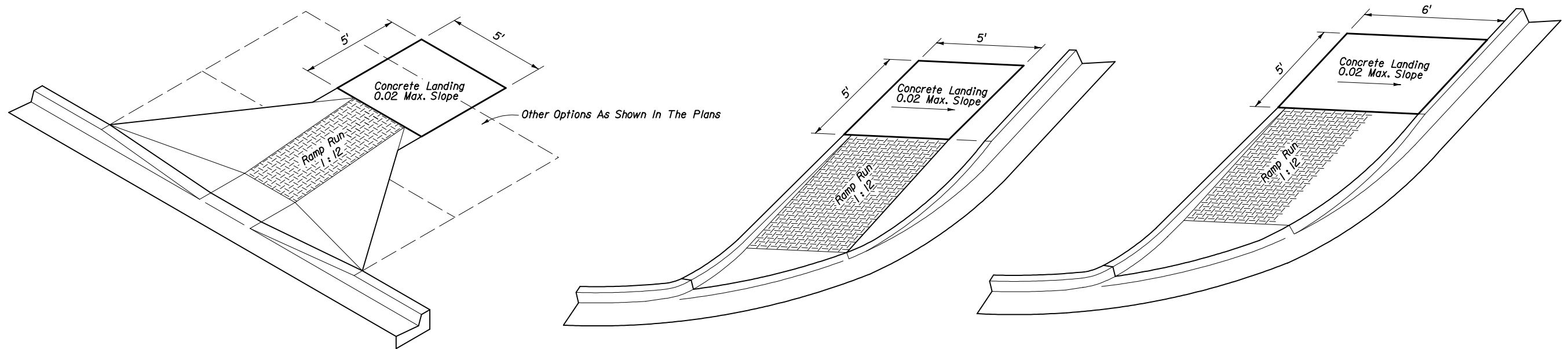

LANDINGS FOR RAMPS WITHIN PUBLIC RIGHT OF WAY CONSTRUCTED AT LOCATIONS WHERE FUTURE SIDEWALKS ARE PROPOSED, WHERE STABLE SURFACES OTHER THAN SIDEWALKS ARE PART OF A CONTINUOUS PASSAGE OR WHERE A CURB FALLS ALONG THE CIRCULATION PATH TO PEDESTRIAN ROUTES ON ADJACENT SITES

STATE OF FLORIDA DEPARTMENT OF TRANSPORTATION				
PUBLIC SIDEWALK CURB RAMPS				
Names	Dates	Approved By		
Designed By	STAFF	10/94	<i>Brian Blankenship</i> State Roadway Design Engineer	
Drawn By	HKH	10/94	Revision	Sheet No.
Checked By	JVG	10/94	00	5 of 5
				Index No.
				304