

Foundations apply only to slopes of 1:4 or flatter.

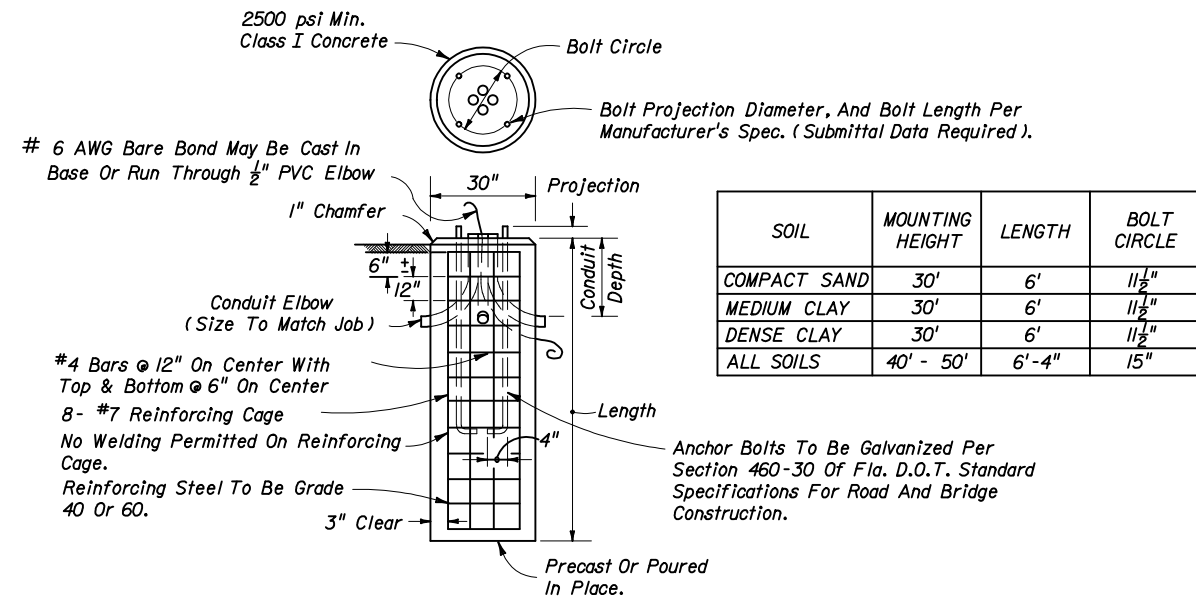

METAL POLE CONCRETE FOUNDATION DETAIL

At All Pull Boxes, And Pole Bases, Ends Of Conduit Shall Be Sealed In Accordance With Section 630 Of The Standard Specifications For Road And Bridge Construction.

All Splices Shall Be Made In Pull Box Or Pole Base With Compression Sleeves Or Split Bolt Connectors Properly Taped And Weatherproofed.

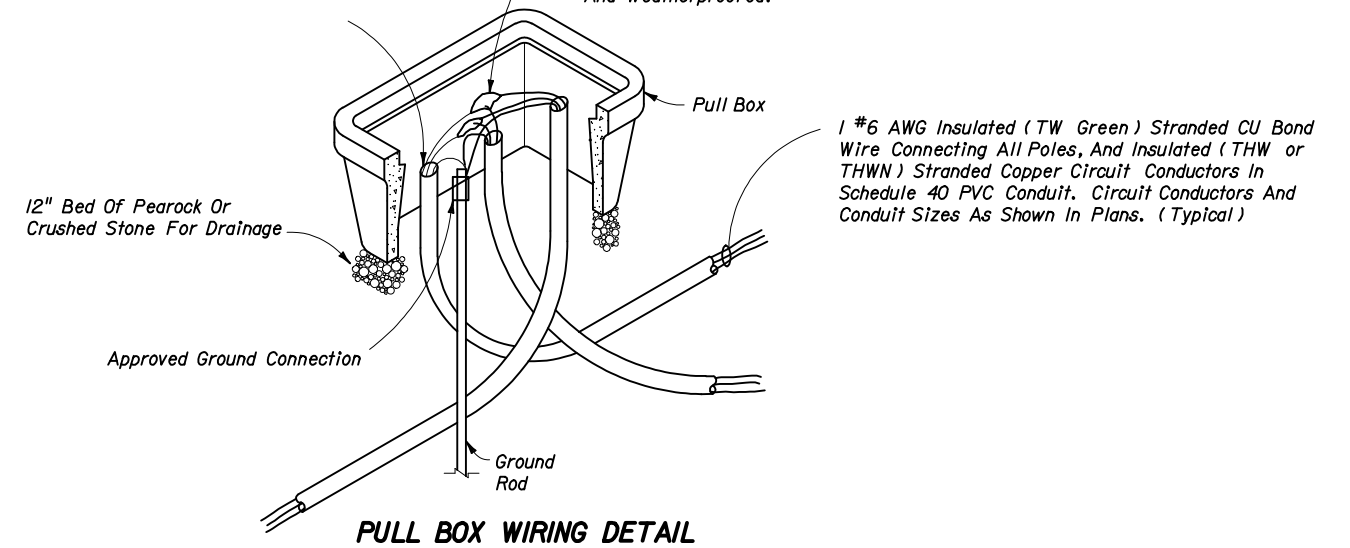

PULL BOX WIRING DETAIL

1 #6 AWG Insulated (TW Green) Stranded CU Bond Wire Connecting All Poles, And Insulated (THW or THWN) Stranded Copper Circuit Conductors In Schedule 40 PVC Conduit. Circuit Conductors And Conduit Sizes As Shown In Plans. (Typical)

STATE OF FLORIDA DEPARTMENT OF TRANSPORTATION				
ROADWAY LIGHTING DETAILS				
Designed By	Names	Dates	Approved By <i>Charles A. Scott</i> State Traffic Standards Engineer	
Drawn By			Revision	Sheet No. 1 of 1
Checked By			00	Index No. 17503