

SLIP BASE AND FOOTING DETAIL

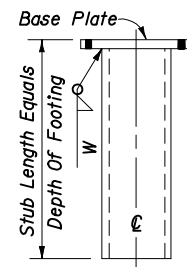

**Stub Size Equals Min. Sleeve Size Or Longer
STUB DETAIL**

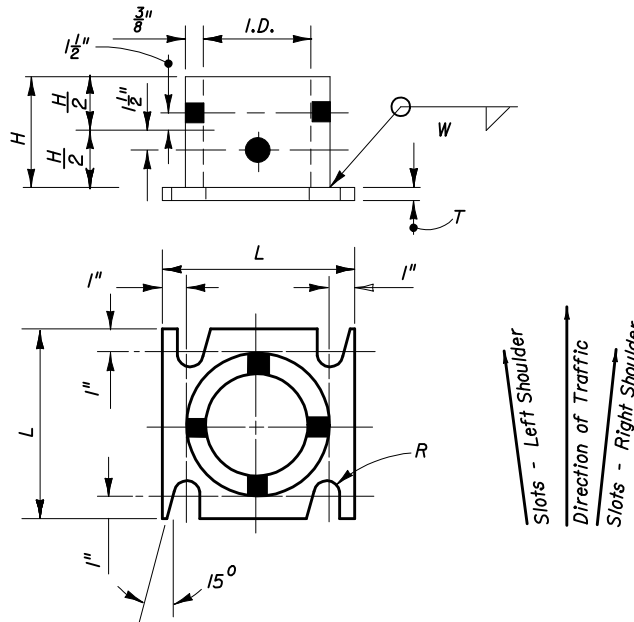

SLEEVE & BASE PLATE DETAILS

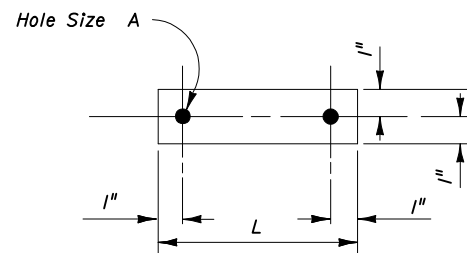

**0.04" Thick Alum. Strip-2 Req'd Per Base
BOLT KEEPER DETAIL**

SLIP BASE DETAILS

Note: Unless noted otherwise, all dimensions are in inches

| Column Size | Sleeve I.D. (Max) | Sleeve Height H | Weld W | Base Plate | | Radius R | Base Bolt | | Base Bolt Torque | | Hole Size A |
|-------------|-------------------|-----------------|--------|------------|-----|----------|-----------|--------|------------------|--------|-------------|
| | | | | L | T | | Size | Length | Ft-lbs | In-lbs | |
| 4 x 1/4 | 4 1/16 | 6 | 5/8 | 8 | 3/4 | 11/32 | 5/8 | 3 | 29 | 355 | 11/16 |
| 4 1/2 x 1/4 | 4 9/16 | 6 | 5/8 | 8 | 7/8 | 11/32 | 5/8 | 3 1/4 | 29 | 355 | 11/16 |
| 5 x 1/4 | 5 1/16 | 7 | 5/8 | 8 | 7/8 | 11/32 | 5/8 | 3 1/4 | 29 | 355 | 11/16 |
| 6 x 1/4 | 6 1/16 | 8 | 11/16 | 9 | 1 | 7/16 | 3/4 | 3 1/2 | 48 | 580 | 13/16 |
| 8 x 5/16 | 8 1/16 | 10 | 3/4 | 11 | 1 | 1/2 | 7/8 | 3 3/4 | 53 | 640 | 15/16 |

NOTES

- Work this Standard with Standard Index Numbers 11860 and 11865.
- To determine column (post) size and footing requirements use the required Sign Identification Number and Sign Height (H), Designs for Heights (H) lower than those listed in the Table are included in Standard Index Number 11865.
- Single Column installations are not allowed for heights (H) exceeding the maximum height shown in the Table, and for sign profiles (Sign Identification Numbers) without any design tabulated. In this event, the sign(s) will have to be supported by multiple columns (posts) featuring breakaway devices. See Standard Index Number 9535.
- The Column (Post) material shall be aluminum. The size is given as outside diameter and wall thickness. Columns (posts) larger than 3 1/2" x 3/16" are non-fragible and shall be installed with breakaway supports and will have concrete footings and slip bases.
- The foundation size is given as outside diameter and depth.
 - Frangible Supports: Foundations for Frangible Supports do not require concrete. The column (post) shall be driven into the ground to the depth indicated.
 - Breakaway Supports: Foundations for Breakaway Supports require concrete. The column support shall be set in a concrete foundation, sized as shown in the table. The first dimension indicates the diameter and the second dimension the depth into the ground. In all cases the ground is to be considered as undisturbed earth, road material, or properly compacted fill.
- SLIP BASE NOTES :
 - The Inside Diameter (I.D.) of the sleeve shall be no more than 1/16" larger than the Outside Diameter (O.D.) of the Column.
 - The sleeve bolts shall be 1/2" Ø with locknuts. The bolts shall be galvanized steel (ASTM A-307) or Aluminum Association Alloy 2024-T4 or 6061-T6 (ASTM B-211).
 - The base bolts, nuts and washers shall be high strength ASTM A-325 and shall have an electroplated zinc coating SC3, Type II applied in accordance with ASTM B633.
 - An alternate cast base of aluminum alloy 356 and T6 temper in lieu of the fabricated base may be submitted for approval by the Engineer. If a cast base is used the stub will be the same as the column and will be bolted to the casting.
 - Assemble the slip base connection in the following manner :
 - Connect column to sleeve using two (2) 1/2" Ø machine bolts.
 - Assemble top base plate to stub base plate using high strength bolts with three (3) hardened washers per bolt. One (1) washer per bolt and two (2) bolt keeper plates go between the base plates.
 - Use shim stock as required to plumb the column.
 - Tighten all bolts the maximum possible with a 12" to 15" wrench to bed the washers and shims and to clear the bolt threads. Loosen each bolt one (1) turn and retighten to the prescribed torque (see table). Bolts shall be tightened with properly calibrated wrenches under the supervision of the project engineer.
 - Burr threads at junction with nut using a center punch to prevent nut loosening.
 - Use galvanized steel shims to obtain a tight fit between the column face and the sleeve. Place shims in all quadrants between the 1/2" Ø sleeve bolts. The shim length shall be 1" shorter than the height of the sleeve.

COLUMN SIZE, COLUMN HEIGHT & COLUMN FOOTINGS

STATE OF FLORIDA DEPARTMENT OF TRANSPORTATION

SINGLE COLUMN GROUND SIGNS

| | | | | | | | |
|-----------|----------------------------|------|-------|----------|-------------|--------------------------------------|-----------|
| 60 | M.P.H. WIND LOADING | | Names | Dates | Approved By | State Structures Design Engineer | |
| | Designed By | DER | 10/94 | Revision | Sheet No. | | Index No. |
| | Drawn By | DDDS | 10/94 | 02 | 1 of 2 | | 11861 |
| | Checked By | RES | 11/94 | | | | |

| COL. SIZE | 2 x 1/8 | 2 1/2 x 1/8 | 3 x 1/8 | 3 1/2 x 3/16 | 4 x 1/4 | 4 1/2 x 1/4 | 5 x 1/4 | 6 x 1/4 | 8 x 5/16 | | | |
|----------------------------|---------------|-------------|---------|--------------|-----------|-------------|-----------|-----------|-----------|--------|----|----|
| FOUNDATION | 0 x 4-0 | 0 x 4-3 | 0 x 4-9 | 0 x 5-3 | 2-0 x 3-9 | 2-0 x 4-0 | 2-0 x 4-3 | 2-0 x 4-9 | 2-0 x 4-9 | | | |
| Sign Identification Number | HEIGHT (Feet) | | | | | | | | | | | |
| | (+) to | (+) to | (+) to | (+) to | (+) to | (+) to | (+) to | (+) to | (+) to | (+) to | | |
| 1 | 15 | 15 | 20 | 20 | 25 | | | | | | | |
| 2 | | | 17 | 17 | 22 | 22 | 25 | | | | | |
| 3 | | | 13 | 13 | 18 | 18 | 25 | | | | | |
| 4 | | | 9 | 9 | 11 | 11 | 18 | 18 | 25 | | | |
| 5 | | | | | | | | | | | | |
| 6 | | | 9 | 9 | 12 | 12 | 18 | 18 | 25 | | | |
| 7 | | | | 6 | 6 | 12 | 12 | 23 | 23 | 25 | | |
| 8 | 15 | 15 | 20 | 20 | 25 | | | | | | | |
| 9 | | | 15 | 15 | 20 | 20 | 25 | | | | | |
| 10 | | | 12 | 12 | 15 | 15 | 22 | 22 | 25 | | | |
| 11 | | | 9 | 9 | 12 | 12 | 18 | 18 | 25 | | | |
| 12 | | | | | 12 | 12 | 22 | 22 | 25 | | | |
| 13 | | | 12 | 12 | 14 | 14 | 22 | 22 | 25 | | | |
| 14 | | | | 12 | 12 | 20 | 20 | 25 | | | | |
| 15 | | | 11 | 11 | 13 | 13 | 20 | 20 | 25 | | | |
| 16 | | | 9 | 9 | 12 | 12 | 18 | 18 | 25 | | | |
| 17 | | | | 9 | 9 | 13 | 13 | 25 | | | | |
| 18 | | | | | 12 | 12 | 23 | 23 | 25 | | | |
| 19 | | | | | 9 | 9 | 18 | 18 | 23 | 23 | 25 | |
| 20 | | | | | | | | | | | | |
| 21 | | | 8 | 8 | 11 | 11 | 17 | 17 | 25 | | | |
| 22 | | | | 11 | 11 | 15 | 15 | 25 | | | | |
| 23 | | | 7 | 7 | 11 | 11 | 16 | 16 | 25 | | | |
| 24 | | | | 10 | 10 | 14 | 14 | 25 | | | | |
| 25 | | | 11 | 11 | 13 | 13 | 20 | 20 | 25 | | | |
| 26 | | | 10 | 10 | 12 | 12 | 20 | 20 | 25 | | | |
| 27 | | | 9 | 9 | 12 | 12 | 18 | 18 | 25 | | | |
| 28 | | | 9 | 9 | 12 | 12 | 18 | 18 | 25 | | | |
| 29 | | | 9 | 9 | 12 | 12 | 18 | 18 | 25 | | | |
| 30 | | | 8 | 8 | 12 | 12 | 16 | 16 | 25 | | | |
| 31 | | | 6 | 6 | 10 | 10 | 14 | 14 | 25 | | | |
| 32 | | | | 8 | 8 | 12 | 12 | 25 | | | | |
| 33 | | | 7 | 7 | 11 | 11 | 16 | 16 | 25 | | | |
| 34 | | | 6 | 6 | 10 | 10 | 14 | 14 | 25 | | | |
| 35 | | | | 10 | 10 | 14 | 14 | 25 | | | | |
| 36 | | | | 9 | 9 | 12 | 12 | 25 | | | | |
| 37 | | | | | 11 | 11 | 21 | 21 | 25 | | | |
| 38 | | | | | 11 | 11 | 20 | 20 | 25 | 25 | 25 | |
| 39 | | | | | 9 | 9 | 18 | 18 | 23 | 23 | 25 | |
| 40 | | | | | | | | | | | | |
| 41 | | | | | | 14 | 14 | 18 | 18 | 23 | 23 | 25 |
| 42 | | | | | | 12 | 12 | 16 | 16 | 20 | 20 | 25 |
| 43 | | | | | | | | | | | | |
| 44 | 16 | 16 | 22 | 22 | 25 | | | | | | | |
| 45 | | | 16 | 16 | 21 | 21 | 25 | | | | | |
| 46 | | | 16 | 16 | 21 | 21 | 25 | | | | | |
| 47 | | | 16 | 16 | 21 | 21 | 25 | | | | | |
| 48 | | | 16 | 16 | 21 | 21 | 25 | | | | | |
| 49 | | | 14 | 14 | 18 | 18 | 25 | | | | | |
| 50 | | | 13 | 13 | 18 | 18 | 25 | | | | | |
| 51 | | | | | 18 | 18 | 25 | | | | | |
| 52 | | | 13 | 13 | 17 | 17 | 25 | | | | | |

| COL. SIZE | 2 x 1/8 | 2 1/2 x 1/8 | 3 x 1/8 | 3 1/2 x 3/16 | 4 x 1/4 | 4 1/2 x 1/4 | 5 x 1/4 | 6 x 1/4 | 8 x 5/16 | | | | |
|----------------------------|---------------|-------------|---------|--------------|-----------|-------------|-----------|-----------|-----------|--------|----|----|----|
| FOUNDATION | 0 x 4-0 | 0 x 4-3 | 0 x 4-9 | 0 x 5-3 | 2-0 x 3-9 | 2-0 x 4-0 | 2-0 x 4-3 | 2-0 x 4-9 | 2-0 x 4-9 | | | | |
| Sign Identification Number | HEIGHT (Feet) | | | | | | | | | | | | |
| | (+) to | (+) to | (+) to | (+) to | (+) to | (+) to | (+) to | (+) to | (+) to | (+) to | | | |
| 53 | | | 13 | 13 | 16 | 16 | 24 | 24 | 25 | | | | |
| 54 | | | 13 | 13 | 16 | 16 | 24 | 24 | 25 | | | | |
| 55 | | | 12 | 12 | 15 | 15 | 23 | 23 | 25 | | | | |
| 56 | | | 11 | 11 | 13 | 13 | 21 | 21 | 25 | | | | |
| 57 | | | 11 | 11 | 13 | 13 | 21 | 21 | 25 | | | | |
| 58 | | | 11 | 11 | 13 | 13 | 20 | 20 | 25 | | | | |
| 59 | | | 11 | 11 | 13 | 13 | 20 | 20 | 25 | | | | |
| 60 | | | 10 | 10 | 12 | 12 | 20 | 20 | 25 | | | | |
| 61 | | | 10 | 10 | 13 | 13 | 19 | 19 | 25 | | | | |
| 62 | | | 9 | 9 | 12 | 12 | 17 | 17 | 25 | | | | |
| 63 | | | | | 12 | 12 | 17 | 17 | 25 | | | | |
| 64 | | | 8 | 8 | 12 | 12 | 17 | 17 | 25 | | | | |
| 65 | | | | | 11 | 11 | 16 | 16 | 25 | | | | |
| 66 | | | | | 11 | 11 | 15 | 15 | 25 | | | | |
| 67 | | | 7 | 7 | 11 | 11 | 15 | 15 | 25 | | | | |
| 68 | | | | | 10 | 10 | 14 | 14 | 25 | | | | |
| 69 | | | | | 10 | 10 | 14 | 14 | 25 | | | | |
| 70 | | | 6 | 6 | 10 | 10 | 14 | 14 | 25 | | | | |
| 71 | | | | | | | | | | | | | |
| 72 | | | | | 9 | 9 | 14 | 14 | 25 | | | | |
| 73 | | | | | 9 | 9 | 13 | 13 | 25 | | | | |
| 74 | | | | | | | | | | | | | |
| 75 | | | | | 7 | 7 | 12 | 12 | 24 | 24 | 25 | | |
| 76 | | | | | 7 | 7 | 12 | 12 | 23 | 23 | 25 | | |
| 77 | | | | | | | 11 | 11 | 23 | 23 | 25 | | |
| 78 | | | | | 7 | 7 | 12 | 12 | 24 | 24 | 25 | | |
| 79 | | | | | | | | | | | | | |
| 80 | | | | | | | 10 | 10 | 19 | 19 | 23 | 23 | 25 |
| 81 | | | | | | | 9 | 9 | 18 | 18 | 23 | 23 | 25 |
| 82 | | | | | | | | | | | | | |
| 83 | | | | | | | | | | | | | |
| 84 | | | | | | | | | | | | | |
| 85 | | | | | | | | | | | | | |
| 86 | | | | | | | 15 | 15 | 19 | 19 | 23 | 23 | 25 |
| 87 | | | | | | | 13 | 13 | 17 | 17 | 21 | 21 | 25 |
| 88 | | | | | | | | | | | | | |
| 89 | | | | | | | | | | | | | |
| 90 | | | | | | | | | | | | | |
| 91 | | | | | | | | | | | | | |

The Column Size is O.D. x Wall Thickness in inches.
The Foundation Size is O.D. x Depth in feet & inches.
A zero O.D. means that a concrete foundation is not necessary.

COLUMN SIZE , COLUMN HEIGHT & COLUMN FOOTINGS

STATE OF FLORIDA DEPARTMENT OF TRANSPORTATION

SINGLE COLUMN GROUND SIGNS

| | | | |
|-------------|-------|-------|----------------------------------|
| | Names | Dates | Approved By <i>[Signature]</i> |
| Designed By | DER | 10/94 | State Structures Design Engineer |
| Drawn By | DDDS | 10/94 | Revision Sheet No. Index No. |
| Checked By | RES | 11/94 | 02 2 of 2 11861 |

60 M.P.H. WIND LOADING