

Sign Identification Number	SIGN			TYPE OF SIGN BRACKET				Sign Identification Number	SIGN			TYPE OF SIGN BRACKET				Sign Identification Number	SIGN			TYPE OF SIGN BRACKET			
	PROFILE	SIZE	SQ. FT.	WIND ZONE					PROFILE	SIZE	SQ. FT.	WIND ZONE					PROFILE	SIZE	SQ. FT.	WIND ZONE			
				60	70	80	90					60	70	80	90					60	70	80	90
1		24 x 24	1.7	2-I	2-I	2-I	2-I	30		15 x 30 24 x 30	8.1	1-I	1-I	1-I	1-I	55		30 x 24	5.0	2-I	2-I	2-I	2-I
2		30 x 30	2.7	2-I	2-I	2-I	2-I	31		15 x 21 36 x 30	9.7	1-I	1-I	1-I	1-I	56		36 x 48	5.6	2-II	2-II	2-II	2-II
3		36 x 36	3.9	2-I	2-I	2-I	2-I	32		15 x 30 36 x 30	10.6	1-I	1-I	1-I	1-I	57		24 x 36	6.0	2-I	2-I	2-I	2-I
4		48 x 48	6.9	1-II & 1-I	1-II & 1-I	1-II & 1-I	1-II & 1-I	33		12 x 24 24 x 24 15 x 21	8.2	1-I	1-I	1-I	1-I	58		36 x 24	6.0	2-I	2-I	2-I	2-I
5		60 x 60	10.8	DO NOT USE SINGLE COLUMN				34		15 x 30 24 x 24 15 x 21	9.3	1-I	1-I	1-I	1-I	59		30 x 30	6.3	2-I	2-I	2-I	2-I
6		36 Ø	7.1	2-I	2-I	2-I	2-I	35		12 x 24 24 x 30 15 x 21	9.2	1-I	1-I	1-I	1-I	60		30 x 30	6.3	2-I	2-I	2-I	3-I
7		48 Ø	12.6	2-II	2-II	2-II	2-II	36		15 x 30 24 x 30 15 x 21	10.3	1-I	1-I	1-I	1-I	61		36 x 36	6.75	2-I	2-I	2-I	2-I
8		18 x 18	1.9	2-I	2-I	2-I	2-I	37		12 x 24, 12 x 24 24 x 24, 24 x 24 15 x 21	13.6	1-II	1-II	1-II	1-II	62		30 x 36	7.5	2-I	2-I	2-I	2-I
9		24 x 24	3.3	2-I	2-I	2-I	2-I	38		12 x 24, 12 x 24 24 x 24, 24 x 24 15 x 21, 15 x 21	15.2	1-I	1-I	1-I	1-I	63		36 x 30	7.5	2-I	2-I	2-I	2-I
10		30 x 30	5.2	2-I	2-I	2-I	2-I	39		12 x 24, 12 x 24 24 x 24, 24 x 24 15 x 21, 15 x 21	16.4	1-I	1-I	1-I	1-I	64		24 x 48	8.0	2-II	2-II	2-II	2-II
11		36 x 36	7.5	2-I	2-I	2-I	2-I	40		15 x 30, 15 x 30 24 x 30, 24 x 30 15 x 21, 15 x 21	19.2	DO NOT USE SINGLE COLUMN				65		12 x 36 30 x 30	8.2	1-I	1-I	1-I	1-I
12		48 x 48	13.3	2-II	2-II	2-II	2-II	41		12 x 24, 12 x 24 24 x 24, 24 x 24 15 x 21, 15 x 21	20.4	1-II	1-II	1-II	1-II	66		30 x 42	8.8	2-I	2-I	2-II	2-II
13		12 x 24 24 x 24	5.4	1-I	1-I	1-I	1-I	42		15 x 21 24 x 24 12 x 24, 12 x 24 24 x 24, 24 x 24 15 x 21, 15 x 21	22.6	1-I	1-I	1-I	1-I	67		36 x 36	9.0	2-I	2-I	2-I	2-I
14		15 x 30 24 x 24	6.5	1-I	1-I	1-I	1-I	43		12 x 24 24 x 30 15 x 21 12 x 24, 12 x 24 24 x 24, 24 x 24 15 x 21, 15 x 21	25.6	DO NOT USE SINGLE COLUMN				68		36 x 36	9.0	2-I & 1-II	2-I & 1-II	2-I & 1-II	2-I & 1-II
15		12 x 24 24 x 30	6.3	1-I	1-I	1-I	1-I	44		18 x 12	1.5	1-I	1-I	1-I	1-I	69		12 x 36 30 x 30	9.3	1-I	1-I	1-I	1-I
16		15 x 30 24 x 30	7.4	1-I	1-I	1-I	1-I	45		12 x 36	3.0	1-I	1-I	1-I	1-I	70		30 x 30 18 x 24	9.3	2-I	2-I	2-I	2-I
17		15 x 30 36 x 36	10.8	1-I	1-I	1-I	1-I	46		18 x 24	3.0	2-I	2-I	2-I	2-I	71		48 x 64	9.9	DO NOT USE SINGLE COLUMN			
18		15 x 30 36 x 45	12.6	1-I	1-I	1-I	1-I	47		24 x 18	3.0	2-I	2-I	2-I	2-I	72		30 x 48	10.0	2-II	2-II	2-II	2-II
19		15 x 30 48 x 48	16.7	1-I	1-I	1-I	1-I	48		18 x 18 9 x 12	3.0	2-I	2-I	2-I	2-I	73		12 x 36 36 x 36	10.5	1-I	1-I	1-I	1-I
20		15 x 30 48 x 60	20.1	DO NOT USE SINGLE COLUMN				49		18 x 30	3.8	2-I	2-I	2-I	2-I	74		30 x 54	11.3	DO NOT USE SINGLE COLUMN			
21		12 x 24 24 x 24 15 x 21	7.6	1-I	1-I	1-I	1-I	50		30 x 40	3.9	2-I	2-I	2-I	2-I	75		36 x 48	12.0	2-II	2-II	2-II	2-II
22		15 x 30 24 x 24 15 x 21	8.7	1-I	1-I	1-I	1-I	51		24 x 24	4.0	2-I	2-I	2-I	2-I	76		48 x 36	12.0	2-I	2-I	2-I	2-I
23		12 x 24 24 x 30 15 x 21	8.5	1-I	1-I	1-I	1-I	52		24 x 24	4.0	2-I	2-I	2-I	2-I	77		36 x 36 18 x 24	12.0	2-I & 1-II	2-I & 1-II	2-I & 1-II	2-I & 1-II
24		15 x 30 24 x 30 15 x 21	9.6	1-I	1-I	1-I	1-I	53		18 x 36	4.5	2-I	2-I	2-I	2-I	78		48 x 48	12.0	1-I & 1-II	1-I & 1-II	1-I & 1-II	1-I & 1-II
25		12 x 24 24 x 24	6.0	1-I	1-I	1-I	1-I	54		30 x 30	4.7	2-I	2-I	2-I	2-I	79		30 x 60	12.5	DO NOT USE SINGLE COLUMN			
26		24 x 24 15 x 21	6.2	2-I	2-I	2-I	2-I							80		48 x 48	16.0	2-II	2-II	2-II	2-II		
27		15 x 30 24 x 24	7.1	1-I	1-I	1-I	1-I							81		48 x 48	16.0	2-I & 1-II	2-I & 1-II	2-I & 1-II	2-I & 1-II		
28		12 x 24 24 x 30	7.0	1-I	1-I	1-I	1-I							82		30 x 78	16.3	DO NOT USE SINGLE COLUMN					
29		24 x 30 15 x 21	7.2	2-I	2-I	2-I	2-I							83		30 x 84	17.5	DO NOT USE SINGLE COLUMN					
														84		48 x 54	18.0	DO NOT USE SINGLE COLUMN					
														85		42 x 66	19.3	DO NOT USE SINGLE COLUMN					
														86		60 x 48	20.0	3-II	3-II	3-II	3-II		
														87		66 x 48	22.0	3-II	3-II	3-II	3-II		
														88		60 x 72	30.0	SEE NOTE					
														89		96 x 48	32.0	DO NOT USE SINGLE COLUMN					
														90		24 x 78	13.0	DO NOT USE SINGLE COLUMN					
														91		36 x 78	19.5	DO NOT USE SINGLE COLUMN					

NOTE:

The Gore Exit Panel (FTP-31, Index 17355, Sheet 3), Sign Identification Number 88, can be installed on a single column with the following stipulations:

1. Maximum height to bottom of sign is 14'.
2. Column size is 6" aluminum round tube with 1/4" wall.
3. 3 Type II Brackets required for attachment.
4. For Type II Bracket details, Attachment and General Notes see Index No. 11860.
5. Footing shall be 2'-0" Ø x 5'-0" deep.
6. Slip Base Details, see Index No. 11863.

Sign size is in inches unless otherwise specified.

STATE OF FLORIDA DEPARTMENT OF TRANSPORTATION

**SINGLE COLUMN
GROUND SIGNS**

Designed By	RBS	10/94	Approved By	
Drawn By	DDDS	10/94	State Structures Design Engineer	
Checked By	DER	11/94	Revision	02
			Sheet No.	1 of 3
			Index No.	11860

GENERAL NOTES

GENERAL SPECIFICATIONS : Florida Department of Transportation Standard Specifications for Road and Bridge Construction (1999) and Supplements thereto.

DESIGN SPECIFICATIONS : Standard Specifications for Structural Supports for Highway Signs, Luminaires and Traffic Signals, AASHTO 1994.

ALUMINUM : Except as noted below, Aluminum Materials shall meet the requirements of Aluminum Association Alloy 6061-T6 (ASTM B209, B221, or B308).

1. Permitted Alternate for Sheets and Plates--- Alloy 5154-H38 (ASTM-B209)

CONCRETE : All concrete shall be Class I (Special), the specified compressive strength at 28 days (f'c) shall be 3 ksi min.

SIGN PANELS : Sign Panels shall be 0.08 inches min. thick Aluminum Plate with all corners rounded. See sign layout sheet. Panels are to be degreased, etched, neutralized and treated with Alodine 1200, Irdine 14-2, Bonderite 721 or equal. No stenciling permitted on panels.

ALUMINUM BOLTS, NUTS & LOCKWASHERS : Aluminum bolts shall meet the requirements of ASTM F468, Alloy 2024-T4. The Bolts shall have an Anodic Coating of at least 0.0002 inches thick and be chromate sealed. Lockwashers shall meet the requirements of Aluminum Association Alloy 7075-T6 (ASTM B221). Nuts shall meet the requirements of ASTM F-467, Alloy 6061-T6 or 6262-T9.

STAINLESS STEEL BOLTS, NUTS AND LOCKWASHERS : Stainless Steel Bolts, Nuts and Lockwashers conforming to ASTM F593 Alloy Group 2 Condition A, CW2, or SH4 may be provided in lieu of Aluminum Bolts, Nuts and Washers.

U-BOLTS, NUTS & LOCKWASHERS : U-Bolts, Nuts and Lockwashers shall meet the requirements of ASTM A307, Grade A and shall be galvanized in accordance with ASTM A153.

INSTALLING FRANGIBLE COLUMN SUPPORTS : Columns (Posts) may be installed by driving the columns in accordance with index Nos. 11861 thru 11865, or as an alternate method the contractor may set the columns (Posts) to the depth indicated in preformed holes backfilled with suitable material tamped in layers not thicker than 6" to provide adequate compaction.

SHOP DRAWINGS : When Type C ground sign supports are furnished and fabricated in accordance with these plans, shop drawings will NOT be required for approval by the Engineer.

HOW TO USE THIS TABLE : Select the appropriate Sign Profile and Size to determine the Sign Identification Number. If the exact Sign Size of all Components are not listed, select the appropriate profile and larger Component Sizes. This table also gives the Quantity and Type of Sign Brackets required for each Sign for each Wind Zone. Where the Sign Size is given as a Vertical and Horizontal Dimension, the Vertical Dimension (Depth) is given first and the Horizontal Dimension (Length) is given last. For Column Sizes, Heights and Footings see appropriate (Wind Zone or Height =14' Max.) sheets titled "Column Sizes, Column Heights and Footings " Index Numbers 11861 thru 11865. No Shop or Field Splice is allowed in Sign Panels. All Panels shall be furnished in one piece.

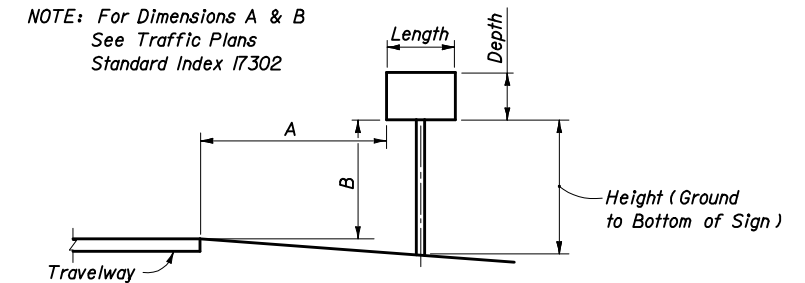

TYPICAL SECTION

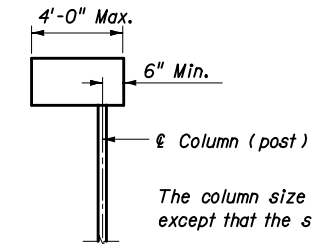

The column size shall be as tabulated in the Standard except that the size shall not be smaller than 3 1/2" Ø.

Note: All cantilever sign installations shall comply with standard Index 17302. The sign shall be supported by an aluminum round column with concrete footing and breakaway support. All sign brackets shall be Type II.

CANTILEVER SIGN

WIND SPEEDS BY COUNTY

ZONE NO. 1 (60 M.P.H.)

Alachua, Baker, Bay, Bradford, Calhoun, Clay, Columbia, Escambia, Gadsden, Gilchrist, Hamilton, Holmes, Jackson, Jefferson, Lafayette, Lake, Leon, Liberty, Madison, Marion, Okaloosa, Putnam, Santa Rosa, Sumter, Suwannee, Union, Walton and Washington Counties.

ZONE NO. 2 (70 M.P.H.)

Citrus, De Soto, Dixie, Duval, Flagler, Franklin, Glades, Gulf, Hardee, Hendry, Hernando, Highlands, Hillsborough, Levy, Nassau, Okeechobee, Orange, Osceola, Pasco, Pinellas, Polk, Seminole, St. Johns, Taylor and Wakulla Counties.

ZONE NO. 3 (80 M.P.H.)

Brevard, Charlotte, Collier, Indian River, Lee, Manatee, Martin, Palm Beach, Sarasota, St. Lucie and Volusia Counties.

ZONE NO. 4 (90 M.P.H.)

Broward, Dade and Monroe Counties.

STATE OF FLORIDA DEPARTMENT OF TRANSPORTATION

SINGLE COLUMN GROUND SIGNS

Names	Dates	Approved By <i>W. V. [Signature]</i>		
Designed By	RES	10/94	State Structures Design Engineer	
Drawn By	DDDS	10/94	Revision	Sheet No.
Checked By	DER	11/94	02	2 of 3
				Index No. 11860

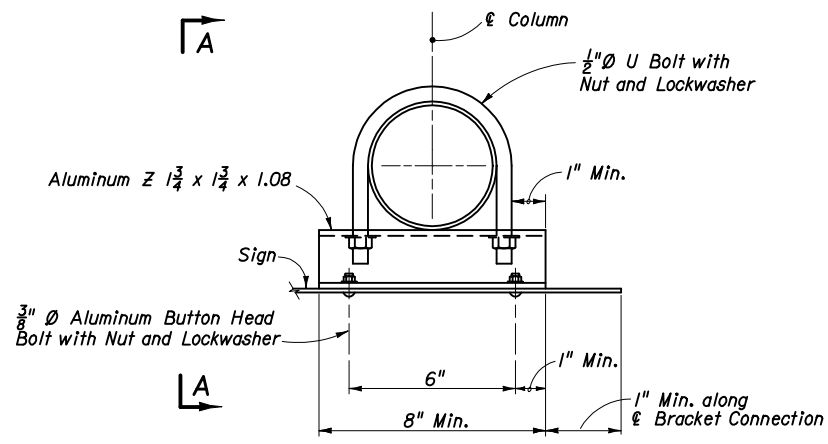

TYPE I BRACKET

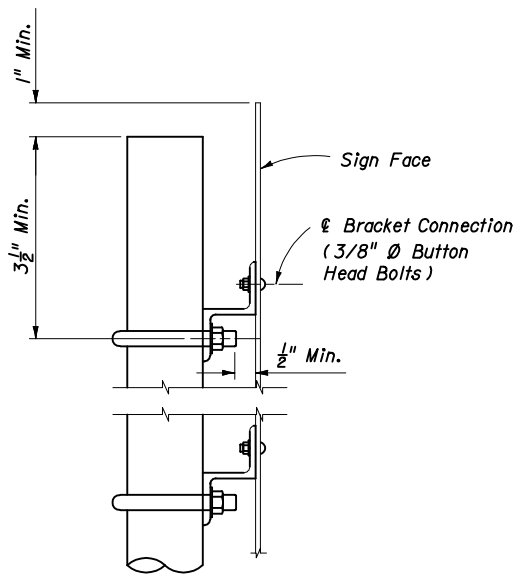

VIEW AA

NOTE: Use profile of largest sign and height to bottom of largest sign to determine column size.

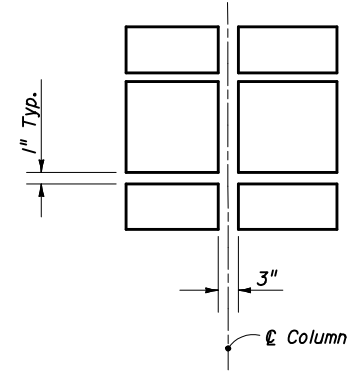

SIGN CLEARANCE

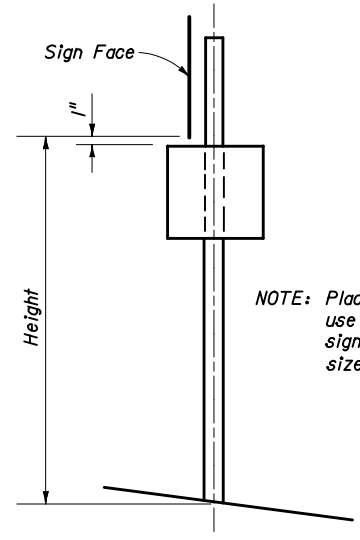

SIGNS AT 90°

NOTE: Place largest sign on top, use profile of largest sign to determine column size.

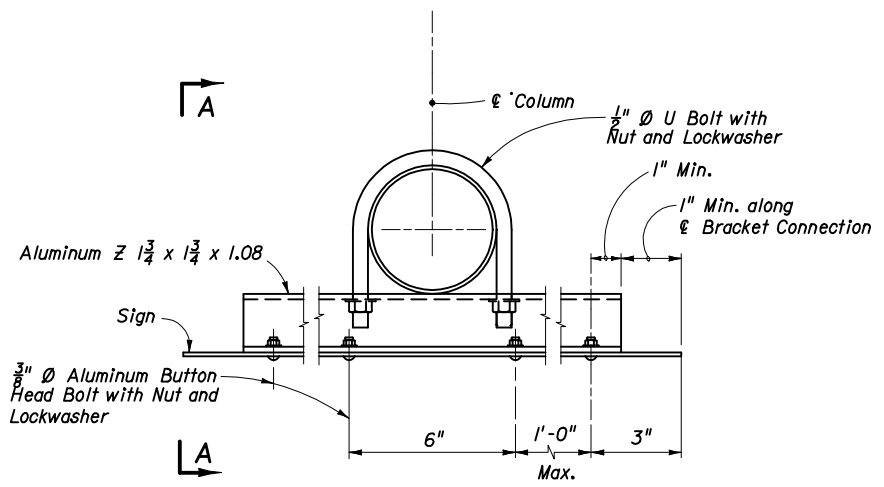

TYPE II BRACKET (SINGLE SIGN)

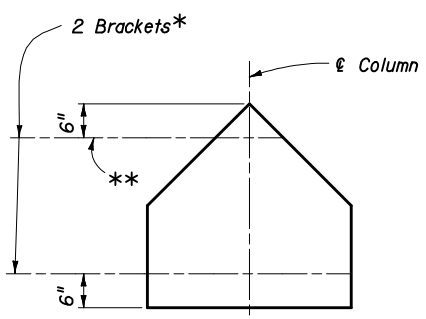

SCHOOL

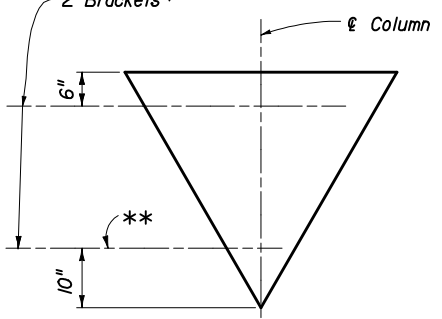

YIELD

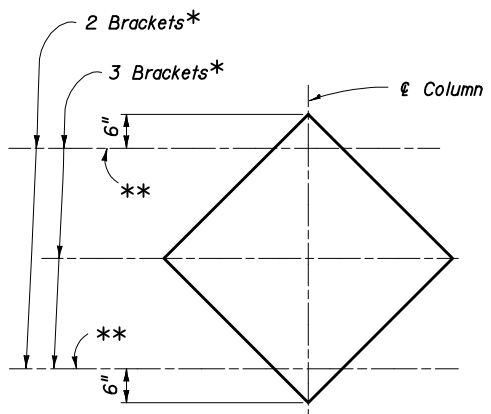

DIAMOND

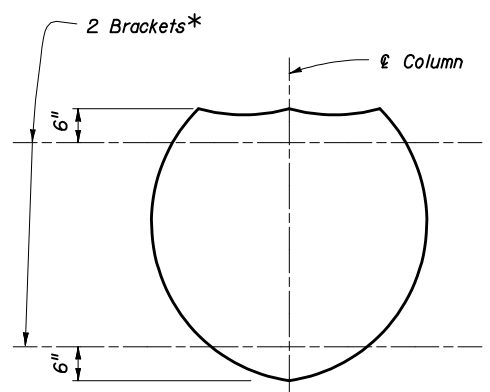

SHIELD

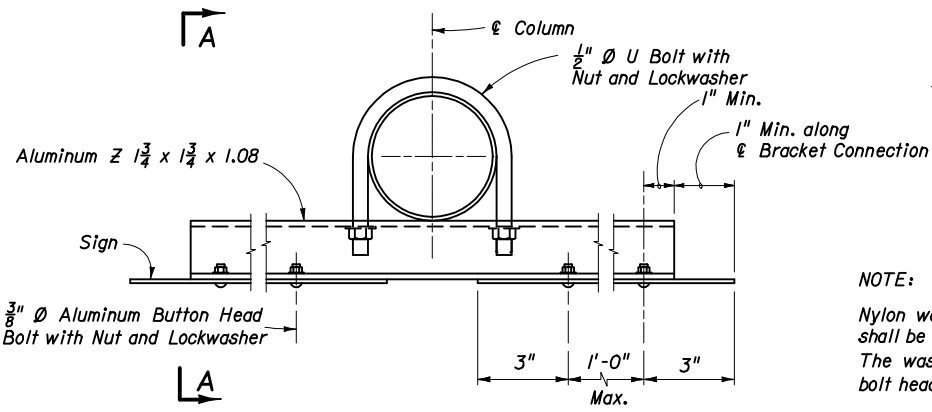

TYPE II BRACKET (DOUBLE SIGNS)

NOTE: 5/16" Stainless Steel Hex Head Bolts with Flat Washer under Head and Lockwasher under Nut may be used in lieu of 3/8" Aluminum Button Head Bolts.

NOTE: Nylon washers provided by the sheeting supplier shall be used on all ground mounted signs. The washers shall be installed under the sign bolt head to protect the sheeting.

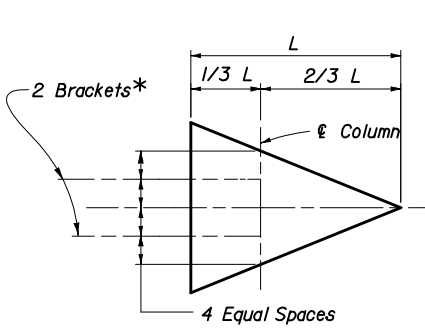

PENDANT

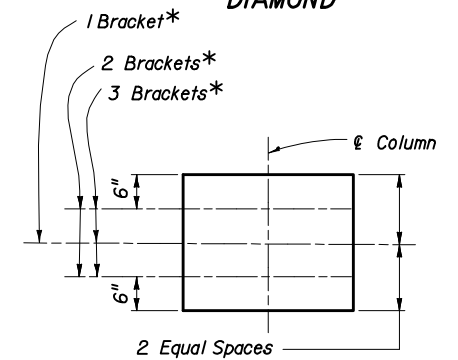

RECTANGLE

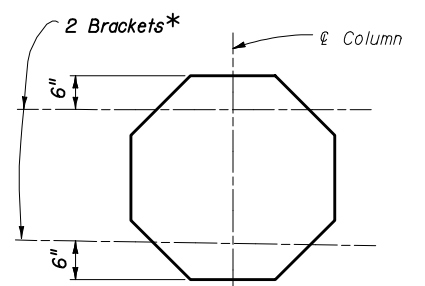

STOP

BRACKET LOCATIONS (SEE VIEW AA)

* NOTE: The above Bracket locations apply at the center of Bracket-Sign Connection (3/8" Button Head Bolts). See View AA. The locations also apply at Double Signs configurations. When installing back-to-back signs the topmost bracket location of one of the signs will require adjustment as shown on the above detail.

** NOTE: Use Type I Bracket at the apex location (always).

STATE OF FLORIDA DEPARTMENT OF TRANSPORTATION

SINGLE COLUMN GROUND SIGNS

Designed By	RES	10/94	Approved By	<i>[Signature]</i>	
Drawn By	DDDS	10/94	Revision	Sheet No.	Index No.
Checked By	DER	11/94	00	3 of 3	11860