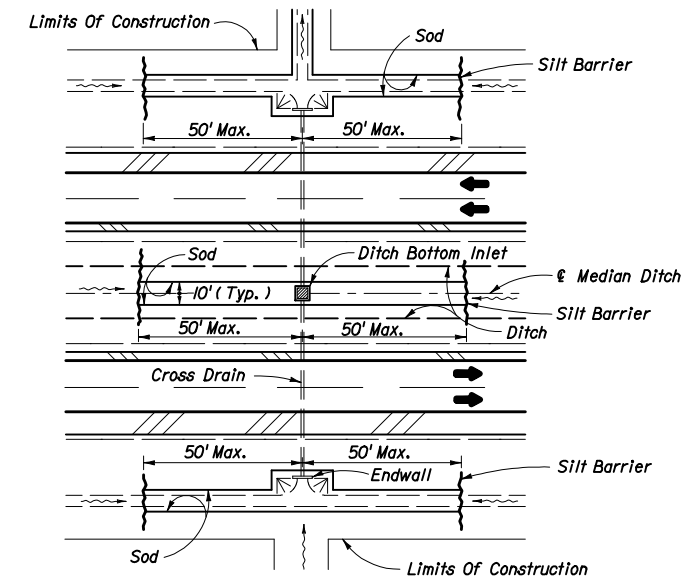

**CHART I**

RECOMMENDED SPACING FOR BALED HAY BARRIERS AND TYPE III SILT FENCE



DITCH INSTALLATIONS AT DRAINAGE STRUCTURES

STATE OF FLORIDA DEPARTMENT OF TRANSPORTATION				
<b>TEMPORARY EROSION AND SEDIMENT CONTROL</b>				
Designed By	EGR	02/80	Approved By <i>S. A. McHenry</i> State Drainage Engineer	
Drawn By	HSD	09/82	Revision	Sheet No. Index No.
Checked By	JVG	09/82	00	1 of 3 102

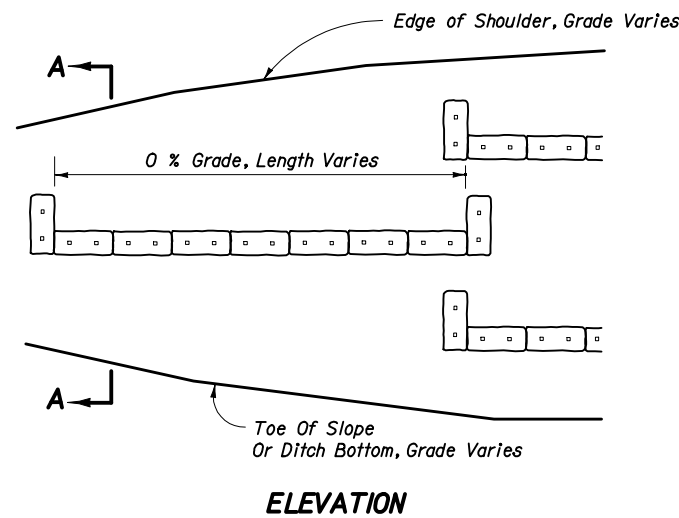
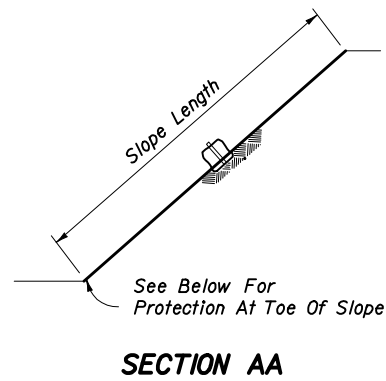
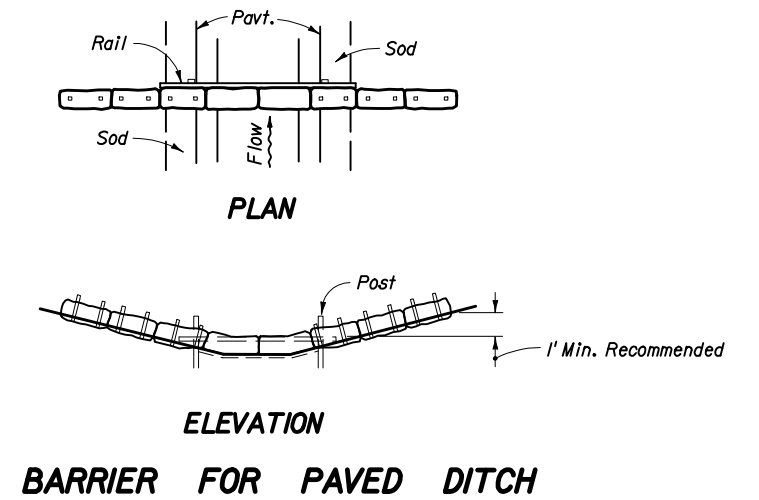
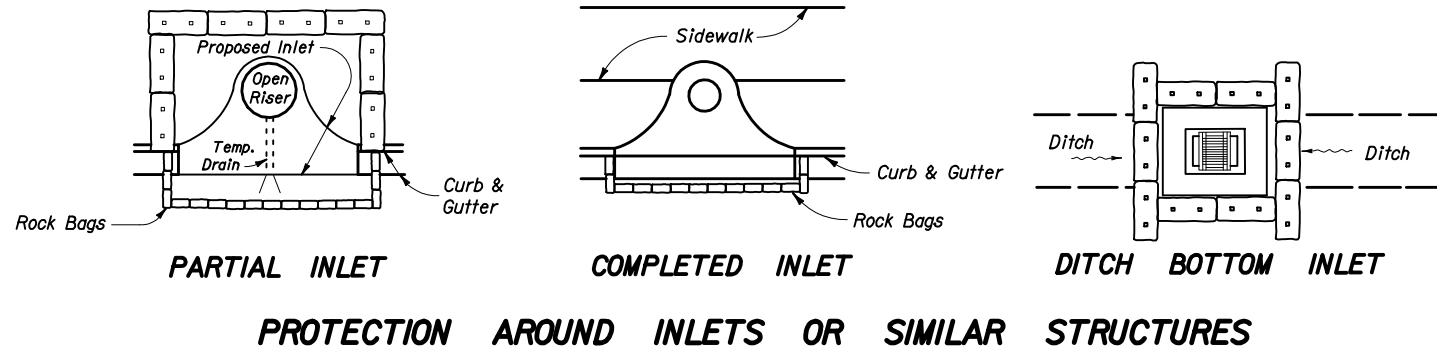

**Note:**  
Where the slope length exceeds 25 feet, construct one row of bale barriers at 0% longitudinal grade midway up the slope. Construct two rows of bale barriers where the slope length exceeds 50 feet.

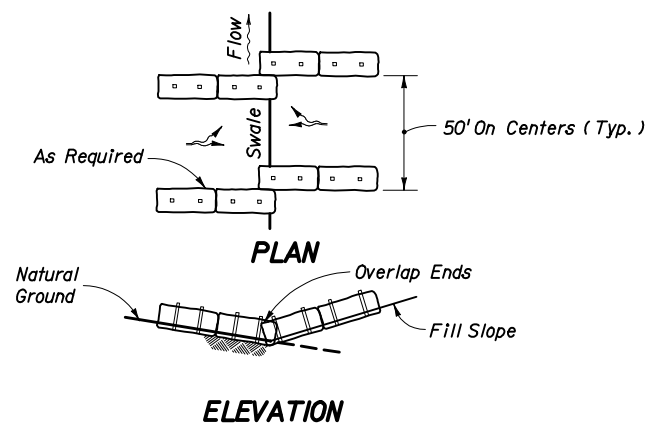
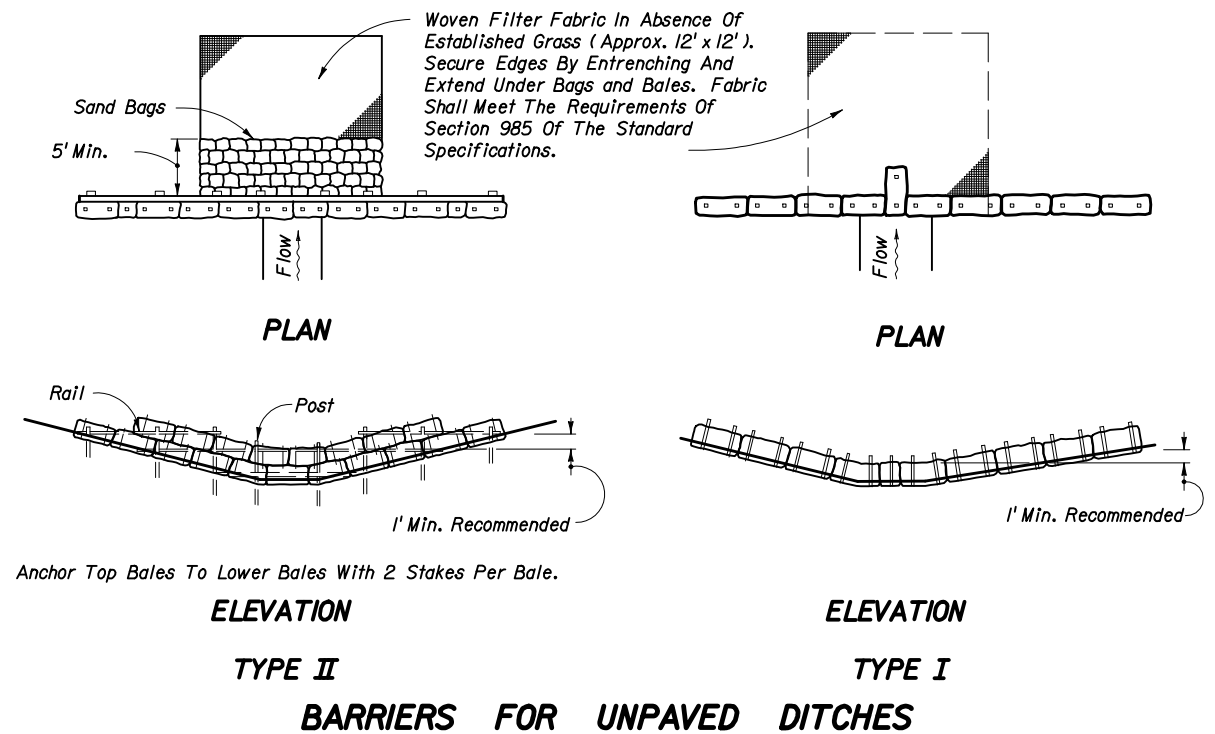

TO BE USED WHERE THE NATURAL GROUND SLOPES TOWARD THE TOE OF SLOPE

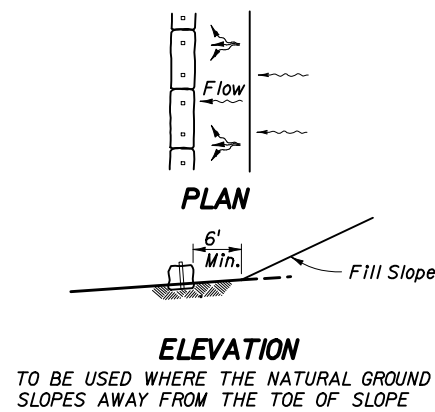

TO BE USED WHERE THE NATURAL GROUND SLOPES AWAY FROM THE TOE OF SLOPE

**AT TOE OF SLOPE**  
**BARRIERS FOR FILL SLOPES**

**NOTES FOR BALED HAY OR STRAW BARRIERS**

- Type I and II Barriers should be spaced in accordance with Chart 1, Sheet 1.
- Hay bales shall be trenched 3" to 4" and anchored with 2 - 1" x 2" (or 1" dia.) x 4' wood stakes. Stakes of other material or shape providing equivalent strength may be used if approved by the Engineer. Stakes other than wood shall be removed upon completion of the project.
- Rails and posts shall be 2" x 4" wood. Other materials providing equivalent strength may be used if approved by the Engineer.
- Adjacent bales shall be butted firmly together. Unavoidable gaps shall be plugged with hay or straw to prevent silt from passing.
- Where used in conjunction with silt fence, hay bales shall be placed on the upstream side of the fence.
- Bales to be paid for under the contract unit price for Baled Hay or Straw, EA. The unit price shall include the cost of filter fabric for Type I and II Barriers. Sand bags shall be paid for under the unit price for Sandbagging, CY. Rock bags to be paid for under the contract unit price for Rock Bags, EA.

STATE OF FLORIDA DEPARTMENT OF TRANSPORTATION				
<b>TEMPORARY EROSION AND SEDIMENT CONTROL</b>				
Designed By	WJR	Dates	5/74	Approved By
Drawn By		Revision		 State Drainage Engineer
Checked By	HLB	6/74	00	
			Sheet No.	Index No.
			2 of 3	102

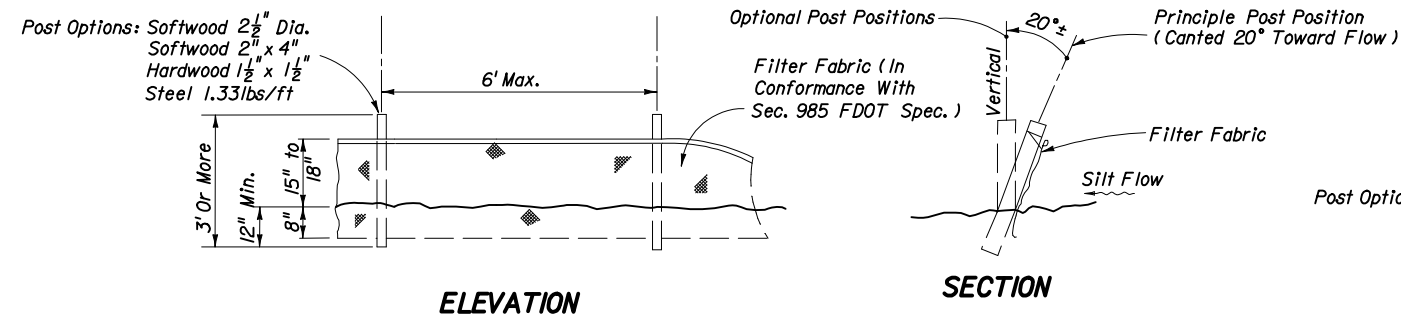

ELEVATION

SECTION

**TYPE III SILT FENCE**

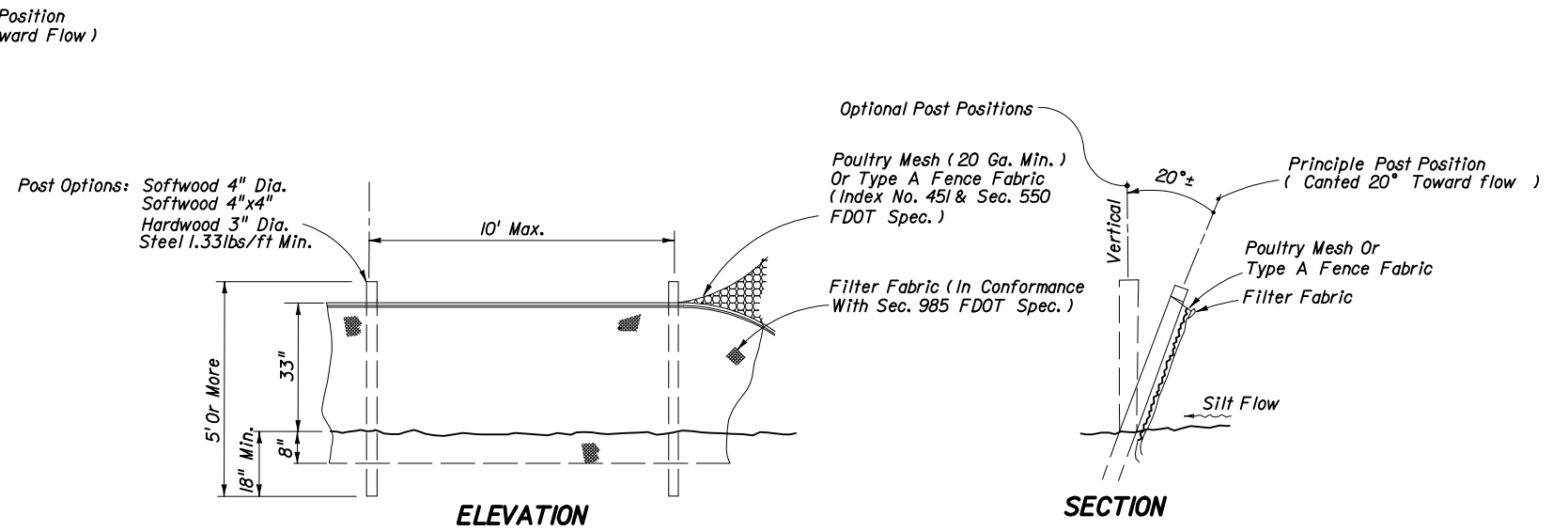

ELEVATION

SECTION

**TYPE IV SILT FENCE**

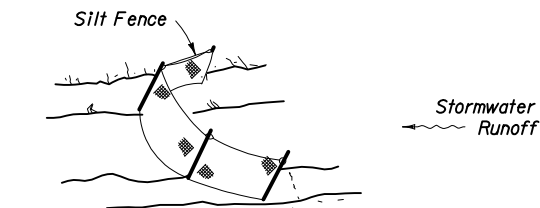
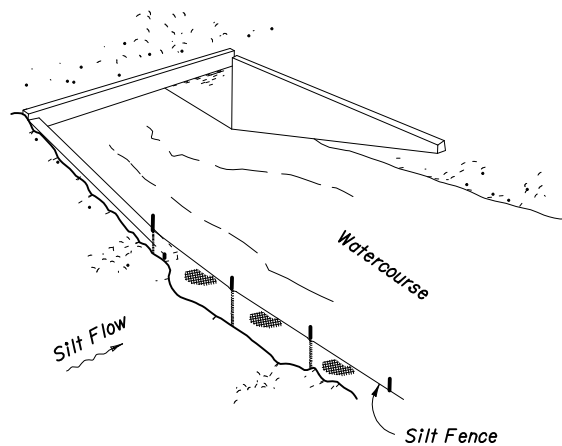

Silt Fence Protection in Ditches with Intermittent Flow

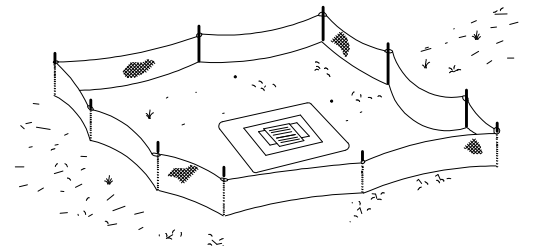

Silt Fence Protection Around Ditch Bottom Inlets.

**SILT FENCE APPLICATIONS**

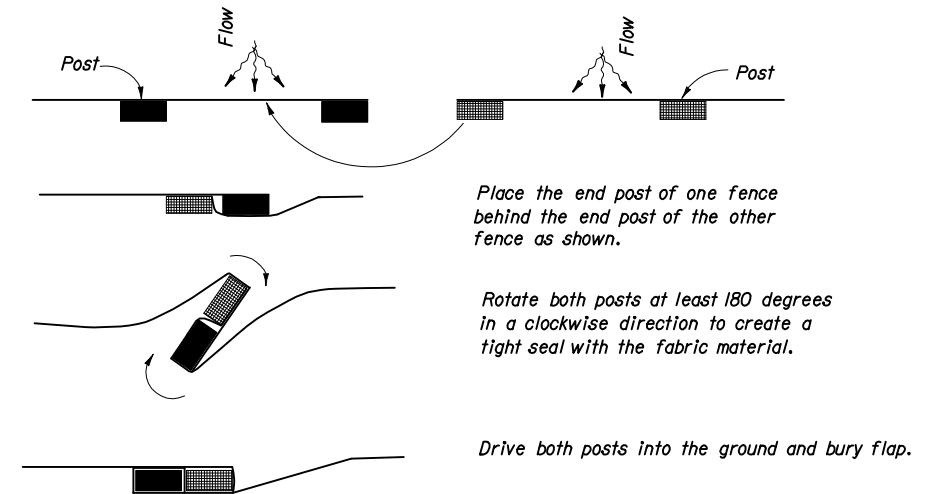

PLAN VIEW

**JOINING TWO SILT FENCES**

**NOTES FOR SILT FENCES**

1. Type III Silt Fence to be used at most locations. Where used in ditches, the spacing for Type III Silt fence shall be in accordance with Chart 1, Sheet 1.
2. Type IV Silt Fence to be used where large sediment loads are anticipated. Suggested use is where fill slope is 1:2 or steeper and length of slope exceeds 25 feet. Avoid use where the detained water may back into travel lanes or off the right of way.
3. Do not construct silt fences across permanent flowing watercourses. Silt fences are to be at upland locations and turbidity barriers used at permanent bodies of water.
4. Where used as slope protection, Silt Fence is to be constructed on 0% longitudinal grade to avoid channelizing runoff along the length of the fence.
5. Silt Fence to be paid for under the contract unit price for Staked Silt Fence, (LF).

STATE OF FLORIDA DEPARTMENT OF TRANSPORTATION				
<b>TEMPORARY EROSION AND SEDIMENT CONTROL</b>				
Names	Dates	Approved By <i>S. A. McHenry</i>		
Designed By RAA/CJA	09/85	State Drainage Engineer		
Drawn By LRE	09/85	Revision	Sheet No.	Index No.
Checked By RAA	10/85	02	3 of 3	102