Report No. BC354 RPWO #48
FINAL REPORT

August 2003

Contract Title: Design Guidelines and Specifications for Engineered Grouts Used in
Anchorage and Pile Splice Applications
UF Project No. 4910 4504 858 12
Contract No. BC354 RPWO #48

DESIGN GUIDELINES AND SPECIFICATIONS FOR ENGINEERED GROUTS

Principal Investigators:	Ronald A. Cook
Graduate Research Assistant:	Jennifer L. Burtz
Project Manager:	Marcus H. Ansley

Department of Civil & Coastal Engineering
College of Engineering
University of Florida
Gainesville, Florida 32611

Engineering and Industrial Experiment Station



1. Report No. BC354 RPWO #48		2. Government Accession No.		3. Recipient's Catalog No.	
4. Title and Subtitle Design Guidelines and Specifications for Engineered Grouts				5. Report Date August 2003	
				6. Performing Organization Code	
				8. Performing Organization Report No. 4910 4504 858 12	
7. Author(s) R. A. Cook and J. L. Burtz				10. Work Unit No. (TRAIS)	
9. Performing Organization Name and Address University of Florida Department of Civil Engineering 345 Weil Hall / P.O. Box 116580 Gainesville, FL 32611-6580				11. Contract or Grant No. BC354 RPWO #48	
				13. Type of Report and Period Covered Final Report	
12. Sponsoring Agency Name and Address Florida Department of Transportation Research Management Center 605 Suwannee Street, MS 30 Tallahassee, FL 32301-8064				14. Sponsoring Agency Code	
				15. Supplementary Notes Prepared in cooperation with the Federal Highway Administration	
16. Abstract <p>Based on experimental test results, a set of design equations were developed for computing the tensile pullout resistance of headed and unheaded single and group grouted anchors. Edge distance and group spacing effects are considered, and values for the critical edge distance and critical anchor spacing are proposed. The results of this testing program, along with those from previous experimental programs, were analyzed to ascertain grout susceptibility to various installation and in-service factors. Stemming from these results, a series of product approval tests was proposed to determine if an engineered grout product is suitable for a desired application.</p>					
17. Key Words grout, anchors, polymer grouts, cementitious grouts			18. Distribution Statement No restrictions. This document is available to the public through the National Technical Information Service, Springfield, VA, 22161		
19. Security Classif. (of this report) Unclassified		20. Security Classif. (of this page) Unclassified		21. No. of Pages 119	22. Price

DESIGN GUIDELINES AND SPECIFICATIONS FOR ENGINEERED GROUTS

Contract No. BC 354 RPWO #48
UF No. 4910 4504 858 12

Principal Investigators:	Ronald A. Cook
Graduate Research Assistant:	Jennifer L. Burtz
FDOT Technical Coordinator:	Marcus H. Ansley

Engineering and Industrial Experiment Station
Department of Civil Engineering
University of Florida
Gainesville, Florida

August 2003

TABLE OF CONTENTS

	<u>page</u>
TABLE OF CONTENTS.....	iv
LIST OF TABLES.....	vii
LIST OF FIGURES.....	viii
CHAPTER	
1. INTRODUCTION.....	1
2. BACKGROUND.....	2
2.1 Types of Anchor Systems.....	2
2.2 Bonded Anchors.....	3
2.2.1 Adhesive Anchors.....	4
2.2.2 Grouted Anchors.....	6
2.3 Previous and Current Studies with Grouted Anchors.....	8
3. BEHAVIORAL MODELS.....	12
3.1 General.....	12
3.2 Concrete Capacity Design (CCD) Method.....	12
3.3 Uniform Bond Stress Model.....	13
4. DEVELOPMENT OF TEST PROGRAM.....	18
4.1 General.....	18
4.2 Single Grouted Anchor Test Program.....	19
4.3 Group Grouted Anchor Test Program.....	21
5. IMPLEMENTATION OF TEST PROGRAM.....	22
5.1 General.....	22
5.2 Concrete.....	22
5.3 Specimen Preparation.....	23
5.4 Installation Procedure.....	24
5.5 Apparatus.....	25

5.6 Loading Procedure	27
5.7 Data Reduction.....	30
5.7.1 Displacement Calculations for Single Anchor Tests	30
5.7.2 Displacement Calculations for Group Anchor Tests	30
6. TEST RESULTS.....	32
6.1 General.....	32
6.2 Single Grouted Anchor Test Results.....	32
6.3 Group Grouted Anchor Test Results.....	35
7. TESTED FACTORS INFLUENCING GROUT BOND STRENGTH.....	37
7.1 General.....	37
7.2 Strength versus Curing Time	37
7.3 Threaded Rod versus Deformed Reinforcing Bar	38
7.4 Threaded Rod versus Smooth Rod	38
7.5 Regular Hex Nut versus Heavy Hex Nut.....	39
7.6 Hole Drilling Technique	40
7.7 Damp Hole Installation.....	40
7.8 Elevated Temperature	41
7.9 Summary	41
8. DISCUSSION ON DESIGN METHOD FOR GROUTED ANCHORS	43
8.1 Current Models	43
8.2 Predicted Model for Grouted Anchor Behavior.....	43
8.3 Proposed Critical Edge Distance and Critical Anchor Spacing Revision.....	44
8.4 Proposed Model for Single Grouted Anchors.....	46
8.5 Proposed Design Model for Grouted Anchor Groups	48
9. DISCUSSION ON PROPOSED PRODUCT APPROVAL TESTS	49
9.1 General.....	49
9.2 Grout/Concrete Bond Stress (τ_0).....	50
9.3 Test Series to Establish Steel/Grout Bond Stress (τ).....	50
9.4 Strength versus Curing Time	51
9.5 Threaded Rod versus Deformed Reinforcing Bar	51
9.6 Hole Drilling Technique	52
9.7 Moisture Condition of Hole	53
9.8 Elevated Temperature	54
9.9 Horizontal and Overhead Hole Orientation (Optional)	54
9.10 Long-term Load (Optional).....	56
9.11 Additional Factors.....	57
10. SUMMARY, CONCLUSIONS, AND RECOMMENDATIONS.....	58

10.1 Summary	58
10.2 Conclusions.....	58
10.3 Recommendations.....	60
 APPENDIX	
A NOTATION.....	62
B TENSILE LOAD VS. DISPLACEMENT GRAPHS FOR BASELINE AND HOLE DRILLING TECHNIQUE TEST SERIES.....	65
C TENSILE LOAD VS. DISPLACEMENT GRAPHS FOR EDGE DISTANCE TEST SERIES.....	72
D TENSILE LOAD VS. DISPLACEMENT GRAPHS FOR GROUP TEST SERIES	77
E REPRESENTATIVE PHOTOGRAPHS OF ANCHOR SPECIMENS FROM TESTING.....	85
F COMPILATION OF PRODUCT APPROVAL TEST RESULTS.....	91
G PROPOSED REVISIONS TO FDOT SECTION 416 TO INCLUDE GROUTED ANCHORS	96
H PROPOSED REVISIONS TO FDOT SECTION 937 TO INCLUDE GROUTED ANCHORS	101
I PROPOSED REVISIONS TO FM 5-568 TO INCLUDE GROUTED ANCHORS ..	105
J RECEIPTS FROM CONCRETE POURS	114
REFERENCE LIST	118

LIST OF TABLES

<u>Table</u>	<u>page</u>
5-1 Summary of testing program for grout product CA	24
5-2 Grout installation summary	25
6-1 Summary of single anchor test results exhibiting bond failure	33
6-2 Summary of baseline single anchor test results	35
6-3 Summary of multiple anchor test results	36
7-1 Summary of tested factors influencing grout bond strength.....	42
B-1 Individual baseline and hole drilling technique anchor test results	66
C-1 Individual edge distance anchor test results.....	73
D-1 Individual group anchor test results.....	78

LIST OF FIGURES

<u>Figure</u>	<u>page</u>
2-1 Types of anchor systems.....	2
2-2 Examples of typical unheaded and headed grouted anchors	7
2-3 Typical bond failures at the steel/grout and grout/concrete interfaces for unheaded grouted anchors.....	7
2-4 Typical bond failure at the grout/concrete interface and concrete cone breakout failure of headed grouted anchors.....	8
3-1 Calculation of A_{N0} for the CCD method	13
3-2 Projected areas for single anchors and anchor groups for the CCD method.....	14
3-3 Calculation of A_{N0} for the uniform bond stress model using the anchor diameter	16
3-4 Projected areas for single anchors and anchor groups for the uniform bond stress model using the anchor diameter	16
3-5 Calculation of A_{N0} for the uniform bond stress model using the hole diameter	16
3-6 Projected areas for single anchors and anchor groups for the uniform bond stress model using the hole diameter	17
5-1 Single anchor test apparatus	27
5-2 Group anchor test apparatus	28
5-3 Minimum reaction positions of test apparatus for headed anchors	28
5-4 Diagram of displacement calculation for individual anchor in group test	31
8-1 Critical edge distance of $8d_0$ compared to experimental results.....	45
8-2 Critical anchor spacing of $16d_0$ compared to experimental results	45
8-3 Critical edge distance of $5d_0$ compared to experimental results.....	46

8-4 Critical anchor spacing of $10d_0$ compared to experimental results	47
B-1 Graphs of test results of first installation of core-drilled anchors.....	67
B-2 Graphs of test results of second installation of core-drilled anchors	68
B-3 Graphs of test results of third installation of core-drilled anchors.....	69
B-4 Graphs of test results of first installation of hammer-drilled anchors	70
B-5 Graphs of test results of second installation of hammer-drilled anchors.....	71
C-1 Graphs of test results of core-drilled anchors installed 4.5 inches away from one edge	74
C-2 Graphs of test results of core-drilled anchors installed 6.0 inches away from one edge	75
C-3 Graphs of test results of core-drilled anchors installed 7.5 inches away from one edge	76
D-1 Graphs of results of first core-drilled anchor group installed with anchor spacing of 5.0 inches.....	79
D-2 Graphs of results of second core-drilled anchor group installed with anchor spacing of 5.0 inches.....	80
D-3 Graphs of results of third core-drilled anchor group installed with anchor spacing of 5.0 inches.....	81
D-4 Graphs of results of first core-drilled anchor group installed with anchor spacing of 9.0 inches.....	82
D-5 Graphs of results of second core-drilled anchor group installed with anchor spacing of 9.0 inches.....	83
D-6 Graphs of results of third core-drilled anchor group installed with anchor spacing of 9.0 inches.....	84
E-1 Typical grout/concrete bond failure of single core-drilled anchor with grout plug.....	85
E-2 Typical grout/concrete bond failure of single anchor with secondary shallow concrete cone	85

E-3 Grout/concrete bond failure of single core-drilled anchor with secondary shallow cone removed and grout plug exposed	86
E-4 Typical grout/concrete bond failure of single hammer-drilled anchor with grout plug	86
E-5 Typical grout/concrete bond failure of single hammer-drilled anchor with secondary shallow concrete cone and grout plug	87
E-6 Typical grout/concrete bond failure of single core-drilled anchor installed 4.5 inches from one edge with grout plug and diagonal cracking of surrounding concrete	87
E-7 Typical grout/concrete bond failure of single core-drilled anchor installed 6.0 inches from one edge with grout plug.....	88
E-8 Typical grout/concrete bond failure of single core-drilled anchor installed 7.5 inches from one edge with grout plug.....	88
E-9 Typical surface view of cone failure of quadruple fastener anchor group with anchor spacing of 5 inches.....	89
E-10 Typical dissection view of cone failure of quadruple fastener anchor group with anchor spacing of 5 inches.....	89
E-11 Typical grout/concrete failure of quadruple fastener anchor group with anchor spacing of 9 inches.....	90
F-1 Strength versus curing time for product CA	91
F-2 Strength versus curing time for product CG	91
F-3 Strength versus curing time for product PB	92
F-4 Comparison of average failure loads for installation with threaded rods and smooth rods	92
F-5 Comparison of average bond stresses for installation with threaded rods and reinforcing bars	93
F-6 Comparison of average failure loads for installation of headed anchors with regular hex nuts and heavy hex nuts.....	93
F-7 Comparison of average failure loads for installation in core-drilled and hammer-drilled holes	94

F-8 Comparison of average bond stresses for installation in damp and dry holes	94
F-9 Comparison of average failure loads for tests performed at ambient and elevated temperatures.....	95

CHAPTER 1 INTRODUCTION

A typical grouted anchor consists of a steel rod and the grout product installed into a hole drilled in hardened concrete. Grout products can be either cementitious or polymer based and installed into the hole with a headed or unheaded anchor. This report explores the behavior of both single and groups of grouted anchors loaded in tension in uncracked concrete. The parameters considered are hole drilling technique, anchor diameter, edge effects, and group effects. These results, along with the results from existing test databases, form the basis for a proposed design model for grouted anchors and product approval tests for engineered grout products.

The American Concrete Institute (ACI) 318-02 (ACI 2002) includes a new Appendix D addressing anchorage to concrete. Design procedures for cast-in-place anchors and post-installed mechanical anchors are included in Appendix D. As a result of extensive testing, the ACI 318 committee is currently working on including adhesive anchors in Appendix D. Grouted anchors are also being considered for inclusion.

CHAPTER 2
BACKGROUND

2.1 Types of Anchor Systems

Anchor fastenings to concrete can be divided into two main categories: cast-in-place and post-installed anchors. Figure 2-1 presents a diagram summarizing the types of anchors available and the products used for installation.

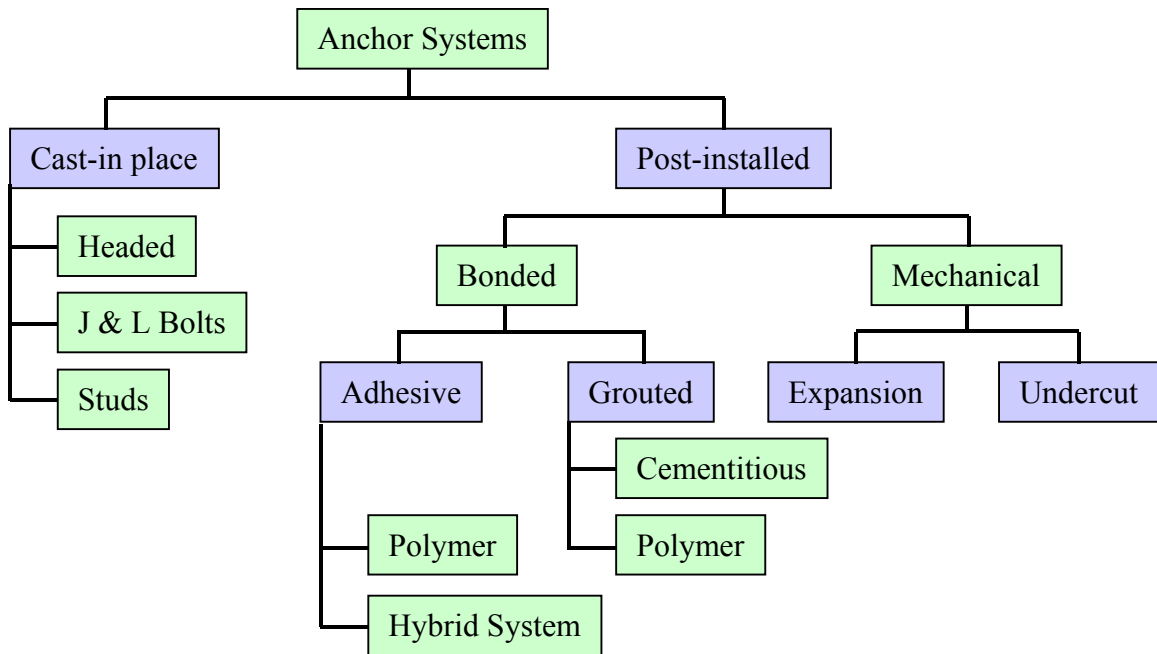

Figure 2-1 Types of anchor systems

Cast-in-place anchors are installed by first connecting them to the formwork prior to pouring concrete. A cast-in-place anchor is typically composed of a headed steel bolt or stud. The main load transfer mechanism is through bearing on the head. Extensive testing has been performed on cast-in-place anchors, and a design model has been

developed to accurately predict their behavior. Systems comprised of cast-in-place anchors behave predictably but are fixed in their location after the concrete is cast.

Post-installed anchors offer more flexibility, and their use is now common. Systems of post-installed anchors include: mechanical (expansion and undercut) and bonded (adhesive and grouted) anchors. Expansion anchors are installed by expanding the lower portion of the anchor through either torque-controlled or displacement-controlled techniques, and load is transferred through friction between the hole and the expanded portion of the anchor. Undercut anchors are installed in a similar manner to expansion anchors, but they possess a slightly oversized hole at the base of the anchor embedment. Load is transferred through bearing of the base of the undercut anchor on the hole. Both adhesive and grouted anchors fall under the heading of bonded anchors. This report is primarily concerned with the comparison of grouted anchors to cast-in-place and adhesive anchors.

2.2 Bonded Anchors

Post-installed bonded anchors can be categorized as either adhesive or grouted. An adhesive anchor can be either an unheaded threaded rod or a deformed reinforcing bar and is inserted into hardened concrete in a predrilled hole that is typically 10 to 25 percent larger than the diameter of the anchor. These anchors are bonded into the hole using a two-part structural adhesive consisting of a resin and a curing agent to bind the concrete and steel together.

Contrastingly, a grouted anchor can be an unheaded threaded rod, a deformed reinforcing bar, a headed bolt, a headed stud, a smooth rod with a nut on the embedded end, or a threaded rod with a nut on the embedded end. Grouted anchors are installed into hardened concrete in predrilled holes that are typically 50 to 200 percent larger than

the diameter of the anchor. For the purposes of this report, the break point between an adhesive anchor and a grouted anchor is when the hole diameter is equal to one and a half times the anchor diameter; all anchors installed in holes greater than or equal one and a half times the anchor diameter shall be considered as grouted anchors.

Engineered grouts can be cementitious or polymer based. Cementitious grouts are composed of primarily fine aggregates, portland cement, and water; polymer grouts are similar in nature to the structural adhesive used to bind adhesive anchors to concrete but also contain a fine aggregate component.

2.2.1 Adhesive Anchors

The curing time of adhesive products is rapid, which makes them ideal for situations requiring a quick set. Different products can be used to install adhesive anchors. These products can be polymers (epoxies, polyesters, or vinylesters) or hybrid systems. Cook et al. (1998) explain that when the resin and curing agent are mixed, the products undergo an exothermic reaction resulting in the formation of a polymer matrix that binds the anchor and the concrete together. Adhesive anchors are typically installed in clean dry holes to attain maximum bond strength. Applied load is transferred from the adhesive anchor to the concrete by one of two mechanisms: mechanical interlock or chemical binding to the concrete.

Cook et al. (1998) proposed a model to design adhesive anchors and to predict anchor strength. This model was developed by comparing the test results from an international test database of single adhesive anchors to several different design models. The uniform bond stress model was proposed and provided the best fit to the database.

McVay et al. (1996) also showed the uniform bond stress model to be rational through comparison of predictions from nonlinear computer analysis to experimental results.

Product approval standards and guidelines for adhesives currently exist in several published documents. The International Congress of Building Officials Evaluation Service (ICBO ES) AC58 (ICBO ES 2001) lists and describes various tests for evaluating adhesive performance under different anchor configurations and installation conditions. The mandatory tests include single anchor tests in tension and in shear, critical edge distance tests for single anchors in tension, tests for critical anchor spacing in anchor groups, and tests for sensitivity to in-service temperature conditions. The Florida Method of Test FM 5-568 (FDOT 2000) describes the tests required by the Florida Department of Transportation (FDOT) for determining the bond strength and sensitivity to installation and service conditions of adhesive bonded anchors and dowels. This document references both the American Society for Testing and Materials (ASTM) E 488-96 (ASTM 2001d) and ASTM E 1512-01 (ASTM 2001e) in respect to how tests on anchor systems should be performed. The FM 5-568 recommends that tension tests, damp hole installation tests, elevated temperature tests, horizontal orientation tests, short-term cure tests, and long-term loading tests be performed on anchor systems. Cook and Konz (2001) experimentally investigated the sensitivity of 20 adhesive products to various installation and service conditions through 765 tests. Installation factors examined included variations in the condition of the drilled hole, concrete strength, and concrete aggregate. Service conditions considered included short-term cure and loading at an elevated temperature.

2.2.2 Grouted Anchors

Grouted anchors can be bonded to concrete with either polymer or cementitious products. Anchors bonded with a polymer grout are intended to be installed into dry holes and under similar conditions as adhesive anchors. Polymer grouts are very similar to adhesive products in composition. Both polymer adhesive products and polymer grouts contain a resin component and a curing agent (hardener), and polymer grouts are additionally comprised of a third component, a fine aggregate that serves as a filler. Polymer grouts usually have a rapid cure time, and anchors can be loaded hours after installation.

The dry components of cementitious grout products are usually prepackaged. Water is added at the time of installation, according to the manufacturer's guidelines, to achieve the desired viscosity. Anchors bonded with a cementitious grout are intended to be installed in clean, damp holes in order to prevent excess water loss into the concrete from the grout, which would reduce the bond strength of the grout. To ensure that this does not occur, manufacturer's often recommend that the holes be saturated by filling them with water for a minimum of 24 hours prior to installation.

Grouted anchors can be installed with or without a head at the embedded end, as shown in Figure 2-2. The presence of a head, or the lack thereof, affects the load transfer mechanism from the anchor to the grout. However, load is transferred from the grout to the concrete primarily through bond and mechanical interlock regardless of the presence or absence of a head.

Unheaded anchors installed by using a threaded rod or a deformed reinforcing bar transfer load to the grout through bond and mechanical interlock. These anchors are

expected to experience a bond failure either at the steel/grout interface or the grout/concrete interface with a secondary shallow concrete cone. Previous testing performed at the University of Florida by Kornreich (2001) and Zamora (1998) confirms that these failure modes occur. Figure 2-3 shows the typical failure modes for unheaded grouted anchors.

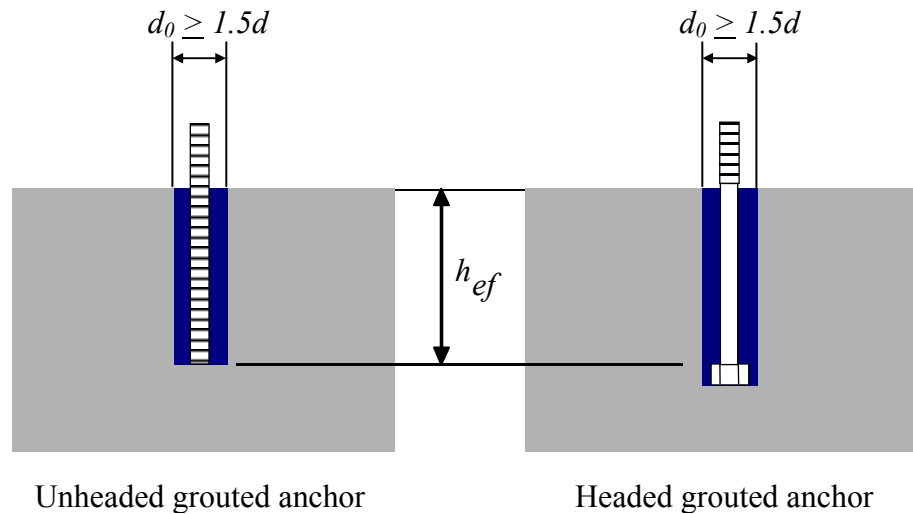

Figure 2-2 Examples of typical unheaded and headed grouted anchors

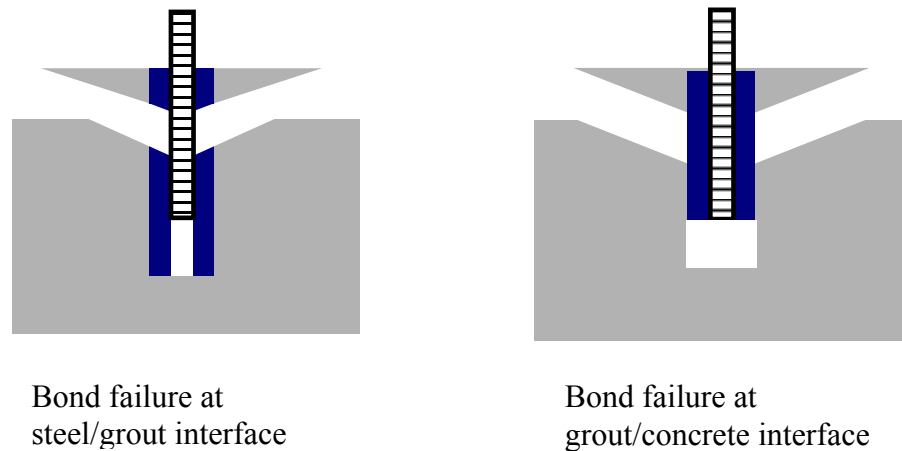

Figure 2-3 Typical bond failures at the steel/grout and grout/concrete interfaces for unheaded grouted anchors

Headed anchors installed with a headed bolt or a smooth rod with a nut at the embedded end of the anchor transfer load to the grout through bearing on the head.

These anchors are expected to fail either in a bond failure at the grout/concrete interface with a secondary shallow cone or in a full concrete cone breakout depending on the bond strength of the grout. Failure at the steel/grout interface is precluded due to the presence of the head. Similar to unheaded grouted anchors, previous testing performed at the University of Florida by Kornreich (2001) and Zamora (1998) confirms these failure modes occur. Figure 2-4 shows the typical failure modes for headed grouted anchors.

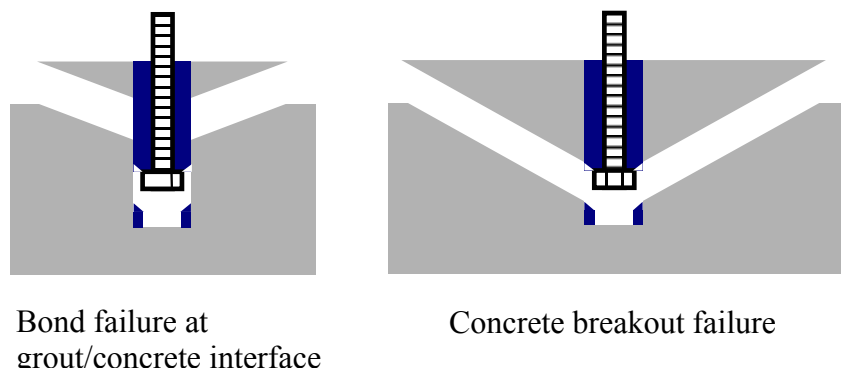

Figure 2-4 Typical bond failure at the grout/concrete interface and concrete cone breakout failure of headed grouted anchors

2.3 Previous and Current Studies with Grouted Anchors

Experimental and analytical studies focusing on the strength and behavior of grouted anchors under tensile load have been presented in published literature. In the earlier stages of grouted anchor research, the theoretical behavior of polymer grouts was examined. James et al. (1987) presented an analysis of post-installed epoxy (polymer) grouted anchors in reinforced concrete based on linear and nonlinear finite element models and comparisons to previously reported experimental data. Parameters considered in this study included various ratios of embedment depth to bolt diameter, different grout properties, and two concrete failure theories: the maximum tensile stress criteria and the Mohr-Coulomb criteria. According to James et al. (1987), when bond

failure occurs at the grout/concrete interface, testing has shown that the load capacity was directly related to the size of the drilled hole. As the hole size increased, the load capacity of the epoxy was increased due to the increase in bond area and displacement of the head of the bolt also increased. If higher strength grouts are utilized, the shear strength of the concrete will control, and failure at the grout/concrete interface is precluded. Additionally, the location of the reaction ring was crucial because, if it was too close to the anchor, it could result in falsely inflated anchor strength.

Other studies were experimental in nature and examined the behavior of polymer and cementitious grouts while varying physical parameters. One such experimental study was reported by Zamora (1998) and contained 290 tension tests on post-installed unheaded and headed grouted anchors. The bond strength of unheaded and headed grouted anchors was tested for influence of anchor diameter, hole diameter, embedment depth, grout product (cementitious or polymer), installation conditions, and concrete strength. A product approval test program for grout products was also investigated, and the following tests were performed: damp hole installation, elevated temperature, threaded rod versus deformed reinforcing bar, regular hex nut versus heavy hex nut, and a test series to establish bond stress at the grout concrete interface. Portions from Zamora (1998) pertaining to behavior and design of grouted anchors installed in uncracked concrete away from a free edge and under tensile load are presented in Zamora et al. (2003). Test results showed unheaded grouted anchors experienced a bond failure and, in general, behaved similar to adhesive anchors, and headed grouted anchors experienced either a bond failure at the grout/concrete interface or a concrete cone breakout. This study recommended that the strength of unheaded grouted anchors be predicted using the

uniform bond stress model; the strength of headed grouted anchors was recommended to be taken as the smaller strength of a bond failure at the grout/concrete interface or a concrete cone breakout. Some differences in bond strengths were found to exist between installation of threaded rods and deformed reinforcing bars when cementitious grouts were utilized. Cementitious grouts experienced a lower bond strength when installed using a heavy hex nut as opposed to a regular hex nut; the effect was opposite for the one polymer grout product tested. Additionally, tests indicated that the bond strength of polymer grouts was generally reduced with an increase in temperature or damp hole installation. These results are discussed in detail in Chapter 7.

In a more recent experimental program, Kornreich (2001) tested post-installed headed and unheaded grouted anchors by varying several parameters. Tests included: grout strength versus curing time, bond of grout to smooth steel, bond of grout to concrete, and basic bond strength at the steel/grout interface. Based on the results obtained, recommended design equations were presented including capacity reduction factors.

In the present report, the results of post-installed headed grouted anchor tests examining the effects of hole drilling technique, edge distance effects, and group spacing effects are presented. The results from previous studies and existing test databases on headed and unheaded grouted anchors and cementitious and polymer grouts are considered. All of this information is combined into recommendations for design specifications for grouted anchors and product approval tests for engineered grout products. Additionally, proposed revisions to current FDOT adhesive-bonded anchor

design and product approval guidelines to include grouted anchors are presented in Appendices G, H, and I.

CHAPTER 3 BEHAVIORAL MODELS

3.1 General

In previous testing programs, grouted anchors were expected to behave in a similar manner to either cast-in-place headed anchors or post-installed adhesive anchors depending on whether the anchors were headed or unheaded. Both cast-in-place headed anchors and post-installed adhesive anchors have been extensively studied, and behavioral models have been developed that accurately predict anchor strength. The Concrete Capacity Design (CCD) method and the uniform bond stress model were therefore used to evaluate the behavior of grouted anchors in this test program, as well as in previous test programs. The development, applicability, and general equations of these models are presented in the following sections.

3.2 Concrete Capacity Design (CCD) Method

Fuchs et al.(1995) first proposed the CCD method in 1995. This model was created to predict the failure loads of cast-in-place headed anchors and post-installed mechanical anchors loaded in tension or in shear that form a full concrete cone. The mean tensile capacity for single cast-in-place headed anchors installed in uncracked concrete is predicted by the following equations:

$$N_{c,0} = 40\sqrt{f'_c} h_{ef}^{1.5} \quad (\text{lbf}) \quad (1a)$$

or

$$N_{c,0} = 16.7\sqrt{f'_c} h_{ef}^{1.5} \quad (\text{N}) \quad (1b)$$

Similarly, the CCD method predicts the tensile capacity of cast-in-place headed anchor groups using the following equations:

$$N_c = \frac{A_N}{A_{N0}} \Psi_{c,e} N_{c,0} \quad (\text{lbf or N}) \quad (2)$$

$$\text{where } \Psi_{c,e} = 0.7 + 0.3 \frac{c}{1.5h_{ef}}$$

Figures 3-1 and 3-2 are adapted from figures found in ACI 318-02 Appendix D (ACI 2002). Figure 3-1 illustrates the calculation of A_{N0} . Figure 3-2 depicts the projected areas for single anchors and groups of anchors for the CCD method as well as the calculation of A_N .

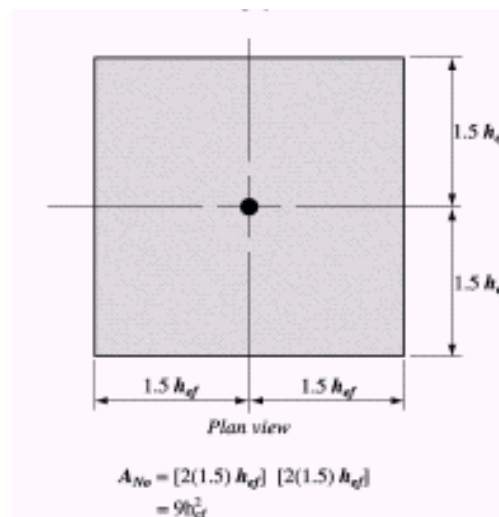

Figure 3-1 Calculation of A_{N0} for the CCD method

3.3 Uniform Bond Stress Model

As mentioned in the previous chapter, Cook et al. (1998) compared several different models, and the uniform bond stress model using the anchor diameter was found

to be the best fit to the test database. As a result, a uniform bond stress can be assumed along the entire embedment depth of the adhesive anchor and accurately predict the bond strength when the embedment length does not exceed 25 times the anchor diameter. For cases where the length exceeds 25 times the anchor diameter, essentially no test data is available. McVay et al. (1996) indicated that analytically the full redistribution of bond stress does not occur when the length exceeds 25 times to anchor diameter. For

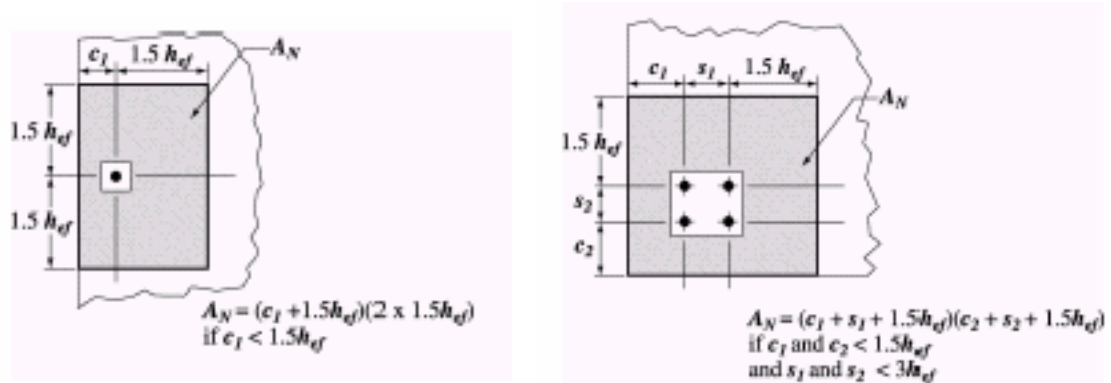

Figure 3-2 Projected areas for single anchors and anchor groups for the CCD method

grouted anchors with the hole diameter greater than or equal to one and a half times the anchor diameter, bond failure can be distinguished at either the steel/grout interface or at the grout/concrete interface. Zamora et al. (2003) presented two variations of this model to account for failure at the inner and outer surfaces of the bonding agent as shown in the following equations for single anchors installed away from a free edge:

$$N_{\tau,0} = \tau \pi d h_{ef} \quad (\text{lbf or N}) \quad (3)$$

$$N_{\tau_0,0} = \tau_0 \pi d_0 h_{ef} \quad (\text{lbf or N}) \quad (4)$$

Lehr and Eligehausen (2001) proposed an extension of the uniform bond stress model for unheaded adhesive anchor groups shown below in Equation (5). This equation could also be applied to grouted anchor groups that experience a bond failure at the steel/grout interface. When bond failure occurs at the grout/concrete interface, Equation (5) may be revised as shown in Equation (6). In this way, the tensile capacity of anchor groups can be predicted by the uniform bond stress model using the following equations:

$$N_{\tau} = \frac{A_N}{A_{N0}} \Psi_{\tau,e} N_{\tau,0} \quad (\text{lbf or N}) \quad (5)$$

$$\text{where } \Psi_{\tau,e} = 0.7 + 0.3 \frac{c}{8d}$$

$$N_{\tau_0} = \frac{A_N}{A_{N0}} \Psi_{\tau_0,e} N_{\tau_0,0} \quad (\text{lbf or N}) \quad (6)$$

$$\text{where } \Psi_{\tau_0,e} = 0.7 + 0.3 \frac{c}{8d_0}$$

Figures 3-3 through 3-6 are adapted for the uniform bond stress model from similar figures for the CCD method found in ACI 318-02 Appendix D (ACI 2002). Figures 3-3 and 3-5 show the calculation of A_{N0} for bond failure at the steel/grout and grout/concrete interfaces, respectively. Figures 3-4 and 3-6 depict the projected areas for single anchors and groups of anchors for the uniform bond stress model as well as the calculation of A_N at the steel/grout and grout/concrete interfaces, respectively.

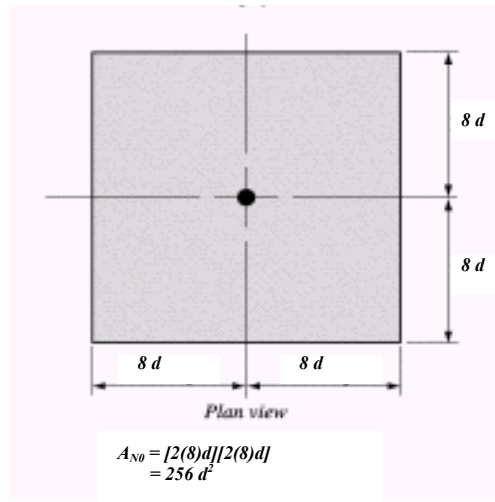

Figure 3-3 Calculation of A_{N0} for the uniform bond stress model using the anchor diameter

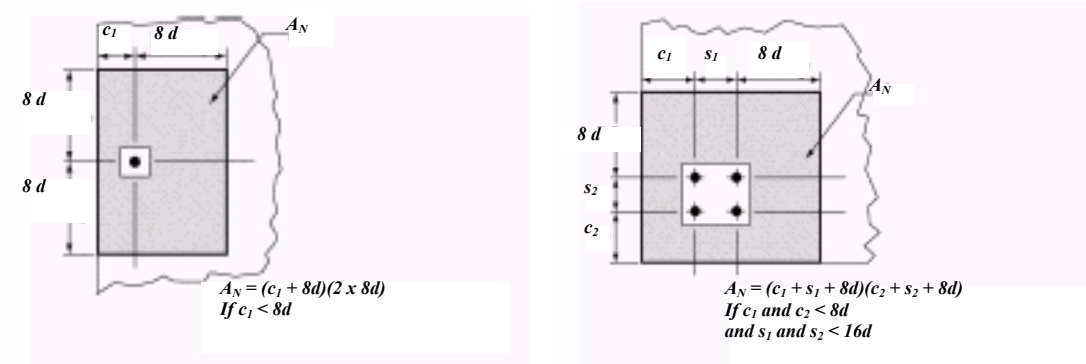

Figure 3-4 Projected areas for single anchors and anchor groups for the uniform bond model

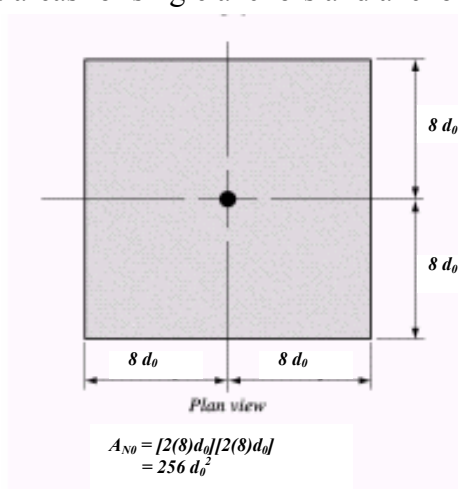

Figure 3-5 Calculation of A_{N0} for the uniform bond stress model using the hole diameter

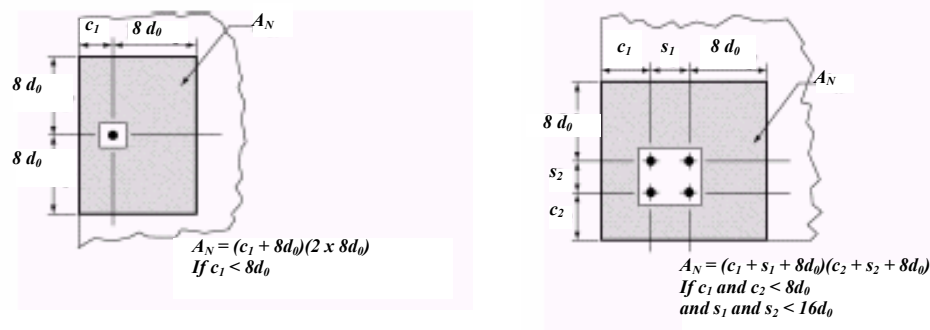

Figure 3-6 Projected areas for single anchors and anchor groups for the uniform bond stress model using the hole diameter

Since adhesive anchors are typically installed in holes with diameters only 10 to 25 percent larger than the anchor diameter, Zamora (1998) conjectured that it is difficult to differentiate between a failure at the steel/grout interface and the grout/concrete interface. However, grouted anchors are usually installed in holes with diameters ranging from 50 to 200 percent larger than the anchor diameter. The larger hole size makes it easier to determine at which interface a bond failure occurred.

Equation (3) has been shown by Cook et al. (1998) to be a good approximation of single adhesive anchor tensile strength even though the interface at which bond failure occurred is not always readily apparent. Similarly, Equation (5) is applicable to groups of adhesive anchors according to Section 7.12 of the Structures Design Guidelines for Load and Resistance Factor Design (FDOT 2002b). In general, both Equation (3) and Equation (4) are applicable to evaluating the strength of single grouted anchors since the interface at which bond failure occurred is more easily observed. For headed grouted anchors experiencing bond failure, only Equation (4) should be considered when determining the tensile strength since failure at the steel/grout interface is precluded by the presence of the head. The applicability of Equation (6) to headed grouted anchor groups will be examined in this test program.

CHAPTER 4 DEVELOPMENT OF TEST PROGRAM

4.1 General

The objective of this test program was to perform additional grouted anchor tests in order to provide a more complete picture of the behavior of engineered grout products. The results of these tests, along with current test databases, will be used to evaluate the applicability of existing design models, to recommend a design model to predict strength of grouted anchors, and to advocate a series of product approval tests to perform in the assessment of engineered grouts. Previous test programs have not fully addressed the failure mode of grouted anchors at the grout/concrete interface. In order to develop a complete design model, this failure mode needs to be further examined.

To investigate the behavior of grouted anchors experiencing this failure mode, this test program chose certain parameters in an attempt to force a failure at the grout/concrete interface. Concrete strength was selected to prevent a concrete cone breakout failure. All anchor specimens were post-installed with a non-shrink cementitious grout product, CA (cementitious grout product A) for the purposes of this report, as headed anchors to preclude a failure at steel/grout interface. In addition, the hole diameter was minimized, allowing only a small clearance between the heavy hex nut of the headed anchor and the side of the hole, to promote a grout/concrete bond failure.

To properly evaluate this failure mode, other anchor parameters were varied. The experimental program included factors often encountered during design and installation of anchors including hole drilling technique (diamond-headed core drill or rotary impact

hammer drill), anchor diameter, edge distance effects, and group spacing effects.

Embedment depth was held constant. The test program was separated into two primary sections: single and group grouted anchor tests. In general, each single anchor series consisted of at least three repetitions, and each group anchor series consisted of three repetitions.

4.2 Single Grouted Anchor Test Program

In the single grouted anchor test program, three separate installations of headed grouted anchors were conducted. Each installation contained a baseline series of anchors grouted into core-drilled holes. All baseline series consisted of three repetitions except the first baseline series, which contained five tests. Other installation parameters were explored in addition to the baseline series of tests to establish which factors affect the general anchor strength and to quantify this effect where present.

The first installation in the single grouted anchor test program was comprised of ten anchors, separated into two series of five, and aimed to test the potential effects of hole drilling techniques. All ten anchors were 0.625 inch (15.9 mm) in diameter, smooth steel rods with threaded ends, and headed using a heavy hex nut. In addition, the embedment depth was 5 inches (127.0 mm) measured from the top of the nut to the top of the concrete, and the edge distance of 12 inches (304.8 mm) was sufficiently large to eliminate concern of edge distance effects. The baseline series consisted of five of the aforementioned anchors damp-installed into core-drilled holes 1.5 inches (38.1 mm) in diameter. The second single anchor series in the first installation varied one factor from the baseline series; these five anchors were damp-installed into hammer-drilled holes 1.5 inches (38.1 mm) in diameter.

The second installation in this test program consisted of 11 anchors with the purpose of examining edge effects and to further inquire into effects arising from hole drilling techniques. All anchors in this installation were 0.75 inch (19.1 mm) in diameter, smooth steel rods with threaded ends, and headed using a heavy hex nut. As in the previous installation, all anchors were embedded 5 inches (127.0 mm), and all holes were 1.5 inches (38.1 mm) in diameter. The baseline series consisted of three anchors damp-installed into core-drilled holes. The second series in this installation contained three anchors damp-installed into hammer-drilled holes. All anchors in both of these series were installed a minimum of 15 inches (381 mm) from the edge of the concrete block to eliminate the possibility of edge effects. The final test series on this installation was comprised of five anchors damp-installed in proximity to a single edge. These anchors were 7.5 inches (190.5 mm) from one edge and a minimum of 24 inches (609.6 mm) from all additional edges.

The third installation contained 13 anchors and endeavored to observe edge distance effects in more detail. All anchors in this installation were 0.75 inch (19.1 mm) in diameter, smooth steel rods with threaded ends, and headed with a heavy hex nut. Again, all anchors were embedded 5 inches (127.0 mm); all holes were core-drilled and 1.5 inches (38.1 mm) in diameter. The baseline series consisted of three anchors damp-installed and placed a minimum of 15 inches (381 mm) from all edges to preclude this type of effect. The two edge effects series included five anchors damp-installed 6 inches (152.4 mm) from one edge and five anchors damp-installed 4.5 inches (114.3 mm) from one edge. All ten anchors were placed a minimum of 24 inches (609.6 mm) from the remaining edges.

4.3 Group Grouted Anchor Test Program

In the group grouted anchor test program, two separate installations of quadruple fastener headed grouted anchor groups were carried out. In order to evaluate the group effect, the single anchor strength N_0 must be established. For this reason, a baseline series, as discussed in the previous section, was installed in the same concrete on the same day as the group specimens. This allowed for a direct comparison of group strength to the strength of a single anchor.

The first quadruple fastener series of three tests was installed in the first installation. Each anchor group contained four anchors 0.625 inch (15.9 mm) in diameter with smooth steel shafts, threaded ends, and headed using heavy hex nuts. All anchors were embedded 5 inches (127.0 mm) deep in holes 1.5 inches (38.1 mm) in diameter and spaced 5 inches (127.0 mm) from each adjacent anchor to form a square.

The second series of three tests was installed in the third installation. Each anchor group included four anchors 0.75 inch (19.1 mm) in diameter with smooth steel shafts, threaded ends, and headed using heavy hex nuts. All anchors were embedded 5 inches (127.0 mm) deep in holes 1.5 inches (38.1 mm) in diameter and spaced 9 inches (228.6 mm) from each adjacent anchor to form a square.

CHAPTER 5 IMPLEMENTATION OF TEST PROGRAM

5.1 General

This test program consisted of two concrete pours and three sets of anchor installations. All tests were unconfined tension tests and performed in general accordance with applicable sections of ASTM E 488-96 (ASTM 2001d) and ASTM E 1512-01 (ASTM 2001e). General test methods for single and group post-installed and cast-in-place anchorage systems are presented in ASTM E 488. More specific testing procedures for bonded anchors are addressed in ASTM E 1512.

5.2 Concrete

For both pours, concrete was ordered from a local ready-mixed plant that batched, mixed, and delivered the concrete to the University of Florida Structures Laboratory. The first pour occurred on February 22, 2002; the second pour occurred on July 18, 2002. All concrete was FDOT Class II to achieve the compressive strengths necessary to preclude a concrete cone breakout failure. Mix details are located in Appendix J, which contains copies of the delivery receipts. The mix design specified a 28-day compressive strength of 3400 psi, but cylinder tests yielded a compressive strength of 6460 to 7670 psi. Wooden formwork was utilized to construct the seven rectangular blocks in each pour: six blocks 4x4x1.25 feet (1219x1219x381 mm) and one block 4x8x1.25 feet (1219x2438x381 mm). Each block contained a single steel reinforcing mat to accommodate handling stresses and prevent cracking. The reinforcement was located 9 inches (228.6 mm) down from the top surface of the concrete. This distance was greater

than the embedment depth of the anchors, which avoided any interactions during testing and failure. After the concrete was poured, consolidated, and smoothed, the blocks were covered with plastic sheets for three days to cure; the blocks were then removed from the formwork. Blocks were allowed to sit for a minimum of 28 days after pouring to attain adequate strength before drilling holes. Concrete compressive strength was determined through cylinder tests performed in accordance with ASTM C 39-01 (ASTM 2001a).

5.3 Specimen Preparation

Once the concrete had sufficiently cured, the required holes for the anchors were drilled into the concrete blocks by using either a core drill or a hammer drill. The holes were drilled deeper than the desired embedment depth to provide room for the nut, the end of the anchor, and a pocket of grout at the base of each hole. A summary of the dimensions, hole drilling technique, type of anchor installed, and the type of test being performed can be found in Table 5-1.

After the completion of hole drilling, the holes were cleaned according to the grout manufacturer's directions. This was accomplished by first vacuuming out the loose matter resulting from the drilling process. Next, the holes were flushed several times with clean water, and the water was vacuumed out each time. The holes were then brushed, while damp, using a bottlebrush in accordance with the grout manufacturer's directions. The holes were flushed several more times with clean water, and the water was vacuumed out each time. Then the holes were prepared for installation according to the grout manufacturer's instructions. This consisted of filling the cleaned holes with water for a minimum of 24 hours to allow for a damp hole installation. The holes were sealed with duct tape to prevent foreign matter from entering. Just prior to anchor

installation, the duct tape was removed and excess water was vacuumed out. The anchors were cleaned prior to installation using paint thinner as a degreaser according to the grout manufacturer's recommendations.

Table 5-1 Summary of testing program for grout product CA

Installation #	Tested Effect	Hole Type	Anchor Diameter d , in (mm)	Hole Diameter d_o , in (mm)	Embedment Depth h_{ef} , in (mm)	Edge Distance c , in (mm) ^a	Spacing s , in (mm) ^b	# of Tests n
1	Baseline	Core	0.625 (15.9)	1.5 (38.1)	5.0 (127.0)	N/A	N/A	5
1	Hammer	Hammer	0.625 (15.9)	1.5 (38.1)	5.0 (127.0)	N/A	N/A	5
1	Group	Core	0.625 (15.9)	1.5 (38.1)	5.0 (127.0)	N/A	5.0 (127.0)	3
2	Baseline	Core	0.750 (19.1)	1.5 (38.1)	5.0 (127.0)	N/A	N/A	3
2	Hammer	Hammer	0.750 (19.1)	1.5 (38.1)	5.0 (127.0)	N/A	N/A	3
2	Edge	Core	0.750 (19.1)	1.5 (38.1)	5.0 (127.0)	7.5 (190.5)	N/A	5
3	Baseline	Core	0.750 (19.1)	1.5 (38.1)	5.0 (127.0)	N/A	N/A	3
3	Edge	Core	0.750 (19.1)	1.5 (38.1)	5.0 (127.0)	4.5 (114.3)	N/A	5
3	Edge	Core	0.750 (19.1)	1.5 (38.1)	5.0 (127.0)	6.0 (152.4)	N/A	5
3	Group	Core	0.750 (19.1)	1.5 (38.1)	5.0 (127.0)	N/A	9.0 (128.6)	3

^a Edge distances designated as N/A refer to anchors installed at $\geq 8d_o$.

^b Spacing between anchors designated as N/A refers to anchors installed at $\geq 16d_o$.

5.4 Installation Procedure

Three separate anchor installations were performed at the University of Florida Structures Laboratory in 2002. All installations were conducted similarly, and grout cubes were also cast whenever anchors were installed. The compressive strength of the grout product was determined through the testing of grout cubes in accordance to ASTM C 109-99 (ASTM 2001b). The holes were filled approximately 75% full, and the headed anchors were inserted. The anchors were shifted about in the holes to remove any entrapped air and then supported in position at the proper embedment depth. Moist curing occurred for seven days by wrapping the anchors with saturated paper towels and covering the slabs with plastic sheets to retain the moisture.

For the first installation, a field representative from the grout manufacturer was on site to oversee, train, and assist in the installation process. This ensured that the grout was proportioned, mixed, and installed to the manufacturer's specifications. For all installations, the grout product CA was mixed to a fluid consistency with a high torque electric drill and mixing paddle for five minutes. The grout mixture was then subjected to a standard 1725 mL flow cone test in accordance with ASTM C 939-97 (ASTM 2001d). The grout product, date of installation, flow rate, and minimum cure time from all three installations are summarized in Table 5-2. The flow rates fell within the manufacturer's requirements of 25 to 30 seconds with a tolerance of ± 1 second.

Table 5-2 Grout installation summary

Installation #	Date of Installation	Grout Product	Flow Rate (seconds)	Minimum Grout Cure Time (days)
1	April 11, 2002	CA	31	28
2	July 11, 2002	CA	26	14
3	August 22, 2002	CA	25	14

5.5 Apparatus

A schematic diagram of the equipment used in the tension tests for the single grouted anchors can be seen in Figure 5-1. The tests performed were unconfined, since the position of the reactions was in accordance with ASTM E 488. Figure 5-3 shows the positions of these reactions in relation to the anchor specimen. The equipment setup was designed to allow direct measurement of the load and displacement of the single anchor specimens. The test apparatus consisted of the following parts:

- Reaction ring ($Diameter \geq 4h_{ef}$)
- Two steel wide range flange section
- Three steel bearing plates for center apparatus

- One 120 kip (534 kN) hydraulic ram
- One 200 kip (890 kN) load cell
- One 1.125 inch (28.6 mm) diameter pull bar/coupling rod and retaining nut
- Coupling nut
- Steel plate for Linear Variable Differential Transducers (LVDT's)
- Two LVDT's (2 inch range)

The edge distance tests used two steel channels instead of the reaction ring due to the anchor proximity to one edge of the concrete block.

The equipment used in the group grouted anchor tension tests is shown in the schematic diagram in Figure 5-2. These tests were also unconfined due to the position of the reactions as shown in Figure 5-3. The equipment setup was designed to allow direct measurement of the load and displacement for each individual anchor as well as the whole group. The test apparatus consisted of the following parts:

- Reaction ring ($Diameter \geq 4h_{ef} + s$)
- Two steel wide range flange section
- Two steel channels
- Three steel bearing plates for center apparatus
- One pull plate 12x12x2 inches (304.8x304.8x50.8 mm)
- One 120 kip (534 kN) hydraulic ram
- One 200 kip (890 kN) load cell
- Four 100 kip (445 kN) load washers
- One 1.125 inch (28.6 mm) diameter pull bar/coupling rod and

retaining nut

- Four steel angles
- Two steel frames for potentiometers
- Four steel bearing plates for single anchors
- Four potentiometers (1.5 inch range)
- C-Clamps of various sizes

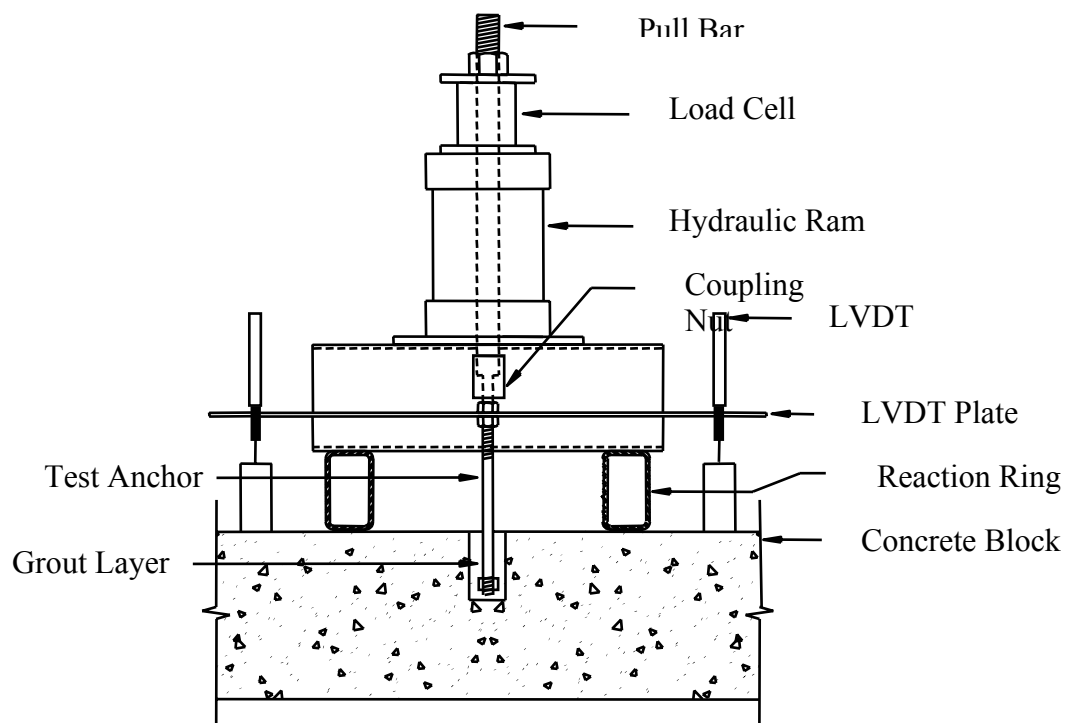

Figure 5-1 Single anchor test apparatus

5.6 Loading Procedure

To pull out a single grouted anchor, the anchor was connected to the coupling rod using a coupling nut. The reaction ring/steel channels and steel flanges were arranged to provide an unconfined test surface. The hydraulic ram was placed atop these supports so that the pull rod passed through its center. The load cell was placed between two bearing

plates above the hydraulic ram. Finally, a retaining nut was tightened down the coupling rod to the topmost bearing plate, and the LVDT's were secured in position.

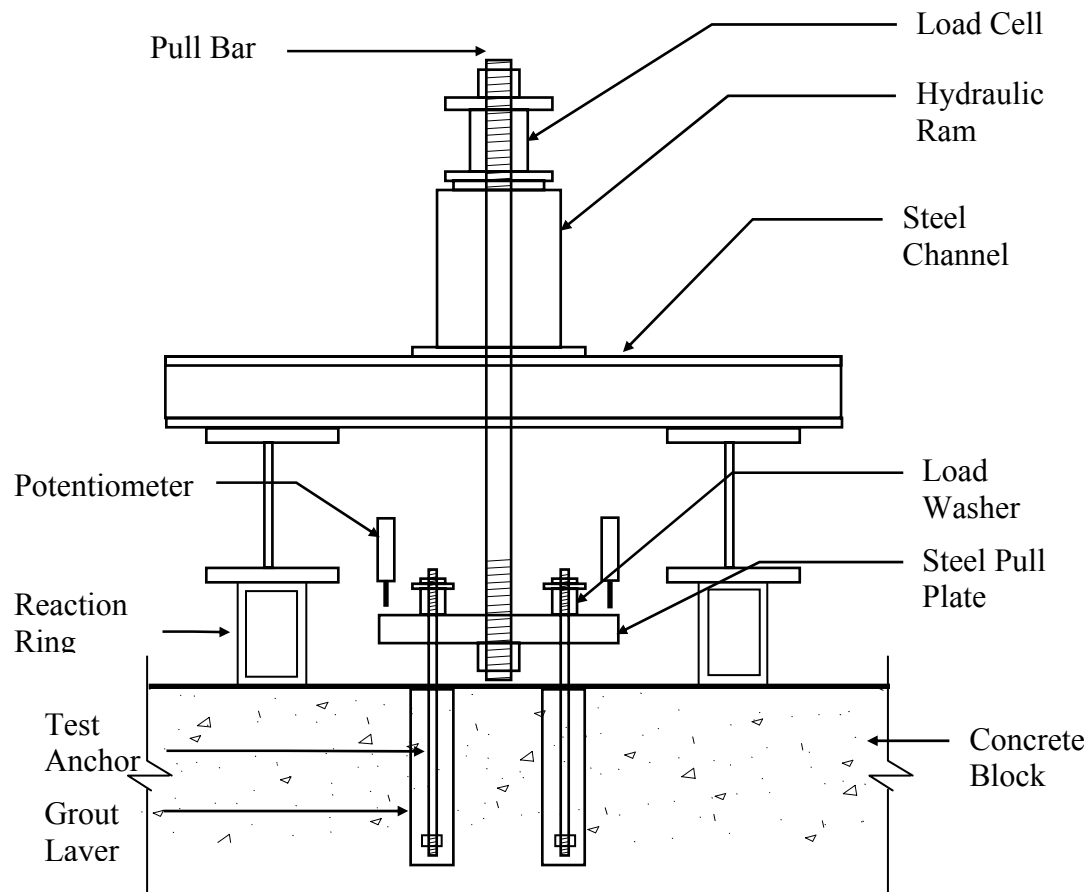

Figure 5-2 Group anchor test apparatus

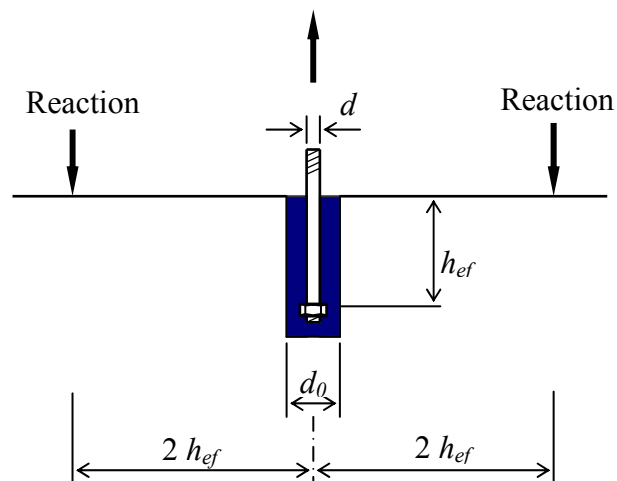

Figure 5-3 Minimum reaction positions of test apparatus for headed anchors

The hydraulic ram was powered and advanced using a 10,000 psi (68,950 MPa) electric pump. The pump was outfitted with two valves. The first controlled the supply to the ram from the pump. The other regulated a bypass from the ram to the oil reservoir. These valves were manually adjusted to control the load applied to the anchor specimen. This setup was used in tandem with a data acquisition system capable of continuously measuring and recording the load and displacement readings.

The typical single anchor testing procedure contained the following steps:

1. Assembling the test apparatus as described above
2. Start data acquisition and LabVIEW software (NI 1999)
3. Adjust the LVDT's to be in range
4. Start pump and pull out anchor
5. Stop test and disassemble apparatus

The loading procedure for the group tests was similar to the single anchor tests. Each anchor passed through holes in the pull plate, and the coupling rod passed through the center hole and was secured with a nut. A load washer was placed on top of each anchor and secured with a bearing plate and a nut. The rest of the test apparatus was assembled as shown in Figure 5-2. The hydraulic ram was operated in the same manner as in the single anchor tests. The data acquisition program was also similar but modified to record the readings from the main load cell, the four load washers, and the four potentiometers.

The typical group anchor testing procedure contained the following steps:

1. Assembling the test apparatus as described above
2. Start data acquisition and LabVIEW software (NI 1999)

3. Adjust the potentiometers to be in range
4. Start pump and pull out anchor
5. Stop test and disassemble apparatus

5.7 Data Reduction

5.7.1 Displacement Calculations for Single Anchor Tests

Single anchor specimens were located directly under the coupling rod. Two LVDT's were used to measure displacement readings. The displacement of a single anchor during testing was calculated by taking the mean of these two readings.

5.7.2 Displacement Calculations for Group Anchor Tests

For each test conducted, the potentiometers were placed at the same location on the pull plate. This position was 5 inches (127 mm) measured from the center of the pull plate through the center of the sides and 7.07 inches (179.6 mm) measured from the center of the pull plate through the corners. Thus, the potentiometers formed a square 10 inches (254 mm) on each side.

All anchor displacements were calculated assuming that the pull plate was rigid. The deflection of each anchor relative to the concrete block was found using displacement readings and the geometry of the test setup.

The overall displacement of the group was computed as the mean of the four potentiometers:

$$d_{tot} = \frac{(d_1 + d_2 + d_3 + d_4)}{4} \quad (\text{inches or mm}) \quad (7)$$

The displacement of the single anchors within the group was calculated according to the test geometry as shown in Figure 5-4:

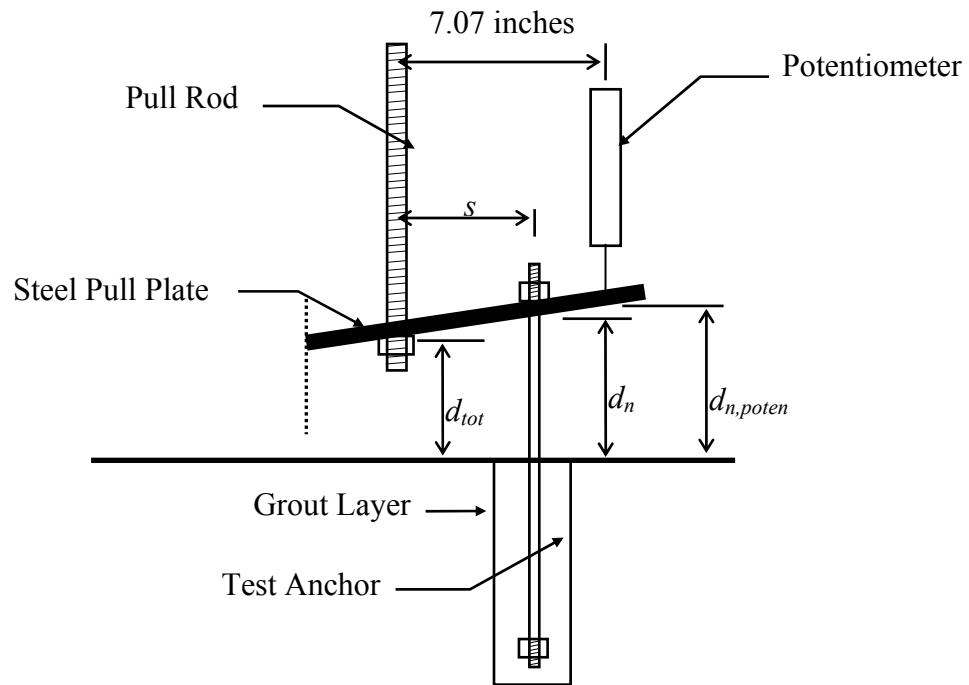

Figure 5-4 Diagram of displacement calculation for individual anchor in group test

$$d_n = d_{tot} + \frac{(d_{n,poten} - d_{tot})s}{7.07} \text{ (inches)} \quad (8a)$$

or

$$d_n = d_{tot} + \frac{(d_{n,poten} - d_{tot})s}{179.6} \text{ (mm)} \quad (8b)$$

CHAPTER 6 TEST RESULTS

6.1 General

The following sections provide a summary of all test series performed. All tests were performed using the same cementitious grout product, CA. A total of three installations were performed. All anchors were post-installed as headed with an effective embedment depth of 5 inches. Appendix B provides the load-displacement graphs and detailed results for baseline and hole drilling technique anchor tests. The load-displacement graphs and detailed results for anchors installed near one edge are presented in Appendix C. Finally, Appendix D contains the load-displacement graphs and detailed results for the quadruple fastener group anchor tests.

6.2 Single Grouted Anchor Test Results

Three types of single anchor tests were performed. First, baseline anchors were installed in core-drilled holes. Second, anchors testing the effects of hole drilling technique were installed in hammer-drilled holes. Finally, anchors were installed in core-drilled holes at various distances from one edge of the concrete block and subsequently tested.

Table 6-1 provides a summary of the test results for each type of single anchor test performed that resulted in bond failure (i.e. tests exhibiting steel failure are excluded from Table 6-1). In general, single anchors experienced a failure at the grout/concrete interface accompanied frequently by the formation of a shallow secondary concrete cone as evidenced by the diagonal cracking that was observed in the concrete after testing.

Frequently, this secondary concrete cone did not remain attached to the anchor during the tension tests, and cracking and spalling of the concrete was observed on the surface of the concrete block in addition to the internal diagonal cracks aforementioned. Photographs of representative failed specimen are contained in Appendix E.

Table 6-1 Summary of single anchor test results exhibiting bond failure

Installation #	Test Series	Tested Effect	N_0 kips (kN)	A_{bond} in ² (mm ²)	τ_0 psi (MPa)	COV	# of Tests in Calculation
1	CD 1	Baseline	29.4 (131)	23.6 (15200)	1250 (8.60)	0.046	5
1	HD 1	Hammer	30.3 (135)	23.6 (15200)	1290 (8.90)	0.012	2
2	CD 2	Baseline	35.1 (156)	23.6 (15200)	1490 (10.3)	0.040	3
2	HD 2	Hammer	29.0 (129)	23.6 (15200)	1230 (8.50)	0.326	3
2	E 7.5	Edge 7.5	31.9 (142)	23.6 (15200)	1350 (9.30)	0.099	5
3	CD 3	Baseline	39.3 (175)	23.6 (15200)	1670 (11.5)	0.097	3
3	E 4.5	Edge 4.5	28.7 (128)	23.6 (15200)	1220 (8.40)	0.086	5
3	E 6.0	Edge 6.0	32.5 (145)	23.6 (15200)	1380 (9.50)	0.070	5

For the first installation, the average bond stress for the baseline series of core-drilled holes was 1250 psi (8.60 MPa) with a coefficient of variation of 0.046. For the test series containing hammer-drilled holes, three of the specimens experienced a steel failure at a level below the ultimate anchor stress capacity specified by the manufacturer. The average bond stress for the remaining two specimens installed in hammer-drilled holes was 1290 psi (8.90 MPa) with a coefficient of variation of 0.012. Normalizing the mean of the hammer-drilled series with the mean of the baseline series yields a ratio of 1.03 times the baseline series bond stress.

In the second installation, the average bond stress for the baseline series of core-drilled holes was 1490 psi (10.3 MPa) with a coefficient of variation of 0.040. Anchors installed in hammer-drilled holes were also tested and resulted in an average bond stress of 1230 psi (8.50 MPa) and a coefficient of variation of 0.326. Normalizing the mean of the hammer-drilled series with the mean of the baseline series yields a ratio of 0.826

times the baseline series bond stress. Anchors were also tested for edge effects in the second installation. The average bond stress for anchors installed in core-drilled holes 7.5 inches away from one edge was 1350 psi (9.30 MPa) with a coefficient of variation of 0.099. Normalizing the mean of the edge distance series with the mean of the baseline series yields a ratio of 0.909 times the baseline series bond stress.

Baseline anchors, as well as those installed near one edge, were tested in the third installation. The average bond stress for the baseline series of anchors installed in core-drilled holes was 1670 psi (11.5 MPa) with a coefficient of variation of 0.097. Anchors installed in core-drilled holes 4.5 inches away from one edge had an average bond stress of 1220 psi (8.40 MPa) with a coefficient of variation of 0.086. Normalizing the mean of the edge distance series with the mean of the baseline series yields a ratio of 0.730 times the baseline series bond stress. Finally, the average bond stress of anchors installed in core-drilled holes 6.0 inches away from one edge was 1380 psi (9.50 MPa) with a coefficient of variation of 0.0700. Normalizing the mean of the edge distance series with the mean of the baseline series yields a ratio of 0.827 times the baseline series of the bond stress.

For further comparison, all 11 baseline test results from the three installations were combined into one database. The average bond stress was 1390 psi (9.60 MPa) with a coefficient of variation of 0.192. The coefficient of variation is less than 0.200, which generally indicates that the grout product's behavior is reasonably consistent when repeated in the given application. FDOT Section 937 (FDOT 2002a) limits the coefficient of variation for uniform bond stress to 20%, which serves as a basis for using

this limit for the purposes of this report. Table 6-2 provides a summary of the tests performed to establish τ_0 for grout product CA in the current report.

Table 6-2 Summary of baseline single anchor test results

Installation #	N_0 kips (kN)	τ_0 psi (MPa)	COV	n
1	29.4 (131)	1250 (8.60)	0.046	5
2	35.1 (156)	1490 (10.3)	0.040	3
3	39.3 (175)	1670 (11.5)	0.097	3
All	32.7 (145)	1390 (9.58)	0.192	11

6.3 Group Grouted Anchor Test Results

Two sets of quadruple fastener group anchor test series were installed and tested. All anchors were installed in core-drilled holes. All parameters, except anchor spacing, were held constant. Table 6-3 provides a summary of the group test series results.

In the first anchor installation, groups of grouted anchors were installed in core-drilled holes with an anchor spacing of 5 inches. All of the repetitions in this test series experienced a concrete cone breakout failure. Due to this, an average bond stress could not be calculated. The average total tensile failure load was 64.1 kips (285 kN) with a coefficient of variation of 0.040. According to the CCD method shown in Equation (2), the predicted strength of the grouted anchor groups with anchor spacing of 5 inches was 69.6 kips.

Groups of grouted anchors were also installed in core-drilled holes in the third installation. In this test series, the anchor spacing was increased to 9 inches. All of the repetitions in this test series exhibited a bond failure at the grout/concrete interface. The average total tensile failure load was 104 kips (460 kN) with a coefficient of variation of 0.027. The average bond stress of the anchor group was 1100 psi (7.60 MPa). The predicted strength of the grouted anchor groups using the diameter of the hole in the

uniform bond stress model was 74.4 kips. This value is conservative, and a revision to the critical spacing will be presented in the proposed design model in Chapter 8.

Table 6-3 Summary of multiple anchor test results

Installation #	Tested Effect	Group in Series	f'_c at test psi (MPa)	Failure Mode ^a	N_{test} kips (kN)	$\tau_{0,test}$ psi (MPa)
1	G 5.0	1	7670 (52.9)	cone	63.4 (282)	NA
1	G 5.0	2	7670 (52.9)	cone	66.9 (298)	NA
1	G 5.0	3	7670 (52.9)	cone	62.0 (276)	NA
<i>Mean N</i>					64.1 (285)	
<i>COV</i>					0.040	
3	G 9.0	1	7330 (50.5)	g/c	105 (465)	1110 (7.65)
3	G 9.0	2	7330 (50.5)	g/c	106 (469)	1119 (7.72)
3	G 9.0	3	7330 (50.5)	g/c	100 (446)	1065 (7.34)
<i>Mean N</i>					104 (460)	
<i>COV</i>					0.027	

^a Tests in which a failure at the grout/concrete interface occurred are designated as g/c.

CHAPTER 7 TESTED FACTORS INFLUENCING GROUT BOND STRENGTH

7.1 General

Grouted anchor performance can be influenced by a wide variety of factors ranging from grout properties, to installation conditions, to loading and environmental conditions while in-service. It is important to understand the effects that various conditions have on grout bond strength to enable proper design of a structure. Testing of a variety of potential effects were performed over the course of several grouted anchor testing programs with the purpose of determining what types of product approval tests might apply to engineered grout products. The following is a written summary of these results. Graphical representations of these results can be found in Appendix F.

7.2 Strength versus Curing Time

Kornreich (2001) performed tests on unheaded threaded rods installed using three different grout products: one polymer (PB) and two cementitious (CA and CG) grouts. Tests were performed at 24 hours, 3 days, 7 days, 14 days, and 28 days. The rate at which the grouts attained their full bond strength appeared to be product dependent. However, the polymer based grout product seemed to reach its full bond strength in a shorter time period; product PB appeared to reach full strength after only 24 hours. Grout CG matured to full strength after 7 days, and grout CA did not attain full strength until 14 days after installation. Currently, FM 5-568 (FDOT 2000) only requires a short-term cure test for adhesive anchors in which tests are performed at only 24 hours.

7.3 Threaded Rod versus Deformed Reinforcing Bar

Zamora (1998) performed tests to investigate the potential differences between the grout bond strength of unheaded threaded rods and deformed reinforcing bars. Four cementitious grout products were examined. Three of the four products experienced a lower bond strength when the grout was installed with a deformed reinforcing bar. Two of these showed small decreases; products CB and CF experienced a reduction in bond strength of 9% and 4%, respectively. However, the bond strength of product CD diminished by 27%. The fourth product, CC, showed a 104% increase in bond strength when installed with deformed reinforcing bars. However, this product is no longer marketed for this application and should not be used to draw conclusions. The effect on bond strength appears to be product dependent, and products should be tested to observe if a significant strength variation, defined as over 20% for the purposes of this report, occurs. This limit on bond strength variation is similar to the limit set forth in ICBO ES AC58 (ICBO ES 2001) for variation between strengths obtained from testing anchors installed in damp holes and in baseline dry holes.

7.4 Threaded Rod versus Smooth Rod

Kornreich (2001) compared the bond strength of grouts for unheaded threaded rods and unheaded smooth rods for both cementitious and polymer grout products. For all three products tested, the bond strength for smooth rods was lower than that for threaded rods. However, the amount of bond strength reduction seemed dependent on the type of grout product installed. Grout products CA and CG experienced an 91% and a 81% reduction in bond strength, respectively. The polymer grout product tested, PB, exhibited a 53% decrease in bond strength. All of these reductions in bond strength are

sufficiently large such that it is recommended that unheaded smooth rods should not be relied upon in tension.

7.5 Regular Hex Nut versus Heavy Hex Nut

Zamora (1998) performed a test series to examine the possible effects that the use of various types of nuts in headed anchor applications have on pullout resistance. The study found that a difference in pullout resistances existed depending on the type of nut that was used.

The pullout resistance of anchors installed with cementitious grouts decreased when a heavy hex nut was used. Products CA, CB, and CC demonstrated a reduction in pullout resistance of 15%, 19%, and 8%, respectively, when installed with a heavy hex nut. Contrastingly, the pullout resistance increased by 10% when anchors were installed using polymer grout product PA and a heavy hex nut instead of a regular hex nut. Since only one polymer grout product was tested, it is unclear if all polymer grouts behave in a similar manner. When installed with a regular hex nut, products CA, CB, CC, and PA exhibited a coefficient of variation of 0.052, 0.136, 0.070, and 0.066, respectively. Products CA, CB, CC, and PA had a coefficient of variation of 0.124, 0.150, 0.093, and 0.034, respectively, when a heavy hex nut was used for installation. The change in pullout resistance appears to be dependent on the grout product used. However, when the regular hex nut and heavy hex nut tests are considered in tandem for each product, the coefficients of variation are 0.126, 0.187, 0.086, and 0.058 for products CA, CB, CC, and PA, respectively. These coefficients of variation are not significant as they are less than 20%, and, therefore, it seems that it is unnecessary to test products using different types of nuts.

7.6 Hole Drilling Technique

Two test series comparing headed anchors installed in hammer-drilled holes to those installed in core-drilled holes were performed in the testing program of the current report. In one test series, there was essentially no difference between the bond strength of anchors installed in the two types of holes. When anchors were installed in hammer-drilled holes, the bond strength increased by 3% with a coefficient of variation of 0.012. A subsequent test series examined the same grout product, CA. It was found that the results of anchors installed in hammer-drilled holes were widely scattered with a coefficient of variation of 0.326, and the average bond strength was 17% lower than the bond strength of the baseline anchors installed in core-drilled holes. Combining the results of both test series yielded a coefficient of variation of 0.244. These tests from different installations could be considered together since each series was normalized with respect to the baseline series of that installation.

It is possible that when the holes were hammer-drilled the pores in the concrete became filled with dust from the drilling process. The presence of this dust could have prevented the grout product from fully bonding to the concrete even though the cleaning procedures recommended by the manufacturer were performed. This could account for the scatter observed in one of the two installations. It is recommended that tests be performed on cementitious grouts to determine if sensitivity to hole drilling technique exists whenever they are to be installed in holes drilled in a manner other than that recommended by the manufacturer.

7.7 Damp Hole Installation

This test series consisted of anchors installed in damp holes free of standing water. Zamora (1998) tested three polymer grouts: PA, PB, and PC. Two of the products

had a noticeable bond strength reduction when installed in damp holes rather than dry holes. Product PB experienced a 17% strength reduction, and product PC exhibited a 27% decrease in bond strength. A third product, PA, experienced a bond strength increase 11%. The effect of a damp hole installation on bond strength seems significant and product dependent. Therefore, polymer grout products should be tested for the effects of this variable on bond strength.

7.8 Elevated Temperature

Anchors installed with polymer grouts are believed to be more sensitive to temperature variations than cementitious products. Zamora (1998) tested two polymer grouts, PA and PB, at elevated temperatures and found a reduction in bond strength of 6% for both products when compared to those tested at ambient temperature. It appears that the bond strengths of these two products are not greatly influenced by elevated temperatures.

However, Cook and Konz (2001) performed similar elevated temperature sensitivity tests on 15 adhesive products. Of the 15 products tested, ten exhibited a bond strength variation of greater than 20%. Adhesive products consist of two components: a resin and a hardener. Polymer grouts contain similar components as adhesives with a filler for the additional third component. Since adhesive products are strongly influenced by elevated temperatures and polymer grout products are similar in composition, it is important to test polymer grout products being for sensitivity to elevated temperature.

7.9 Summary

Previous testing programs, as well as the current testing program, have tested the bond strength sensitivity of various grouts to several installation conditions. The effects of strength versus curing time, threaded rod versus deformed reinforcing bar for

cementitious grouts, threaded rod versus smooth bar, varying types of nuts on headed anchors, hole drilling technique for cementitious grouts, damp hole installation for polymer grouts, and elevated temperature were tested for polymer grouts. Table 7-1 provides a brief summary of the tested variable of interest, the type of grout product installed, and a short explanation of the results of testing.

Table 7-1 Summary of tested factors influencing grout bond strength

Test	Grout Type	
	Cementitious	Polymer
Strength vs. Curing Time	Effect appears product dependent; generally slower than polymer	One product tested
Threaded Rod vs. Deformed Reinforcing Bar	Effect appears product dependent	Not tested
Threaded Rod vs. Smooth Bar	Large reduction in bond strength for both products tested	Reduction in bond strength; one product tested
Regular Hex Nut vs. Heavy Hex Nut	Reduction in pullout resistance for heavy hex; amount appears product dependent	Increase in pullout resistance for heavy hex; unclear if this is a general pattern for polymer products
Hole Drilling Technique	Effect is not consistent and results are at times widely scattered	Not tested
Damp Hole Installation	Not tested	Effect appears product dependent
Elevated Temperature	Not tested	Reduction in bond strength

CHAPTER 8 DISCUSSION ON DESIGN METHOD FOR GROUTED ANCHORS

8.1 Current Models

Previous studies have developed design models for adhesive anchors as well as cast-in-place anchors. Cook et al. (1998) found the uniform bond stress model to be an adequate predictor of adhesive anchor behavior. Similarly, Fuchs et al. (1995) found that the strength of cast-in-place anchors can be accurately predicted using the CCD method. Equations describing the uniform bond stress model and the CCD method are shown in Chapter 3. Modification factors can be applied to both models to account for anchors near a free edge or spaced close enough to act as an anchor group.

8.2 Predicted Model for Grouted Anchor Behavior

Grouted anchors can experience one of three different embedment failure modes: failure at the steel/grout interface, failure at the grout/concrete interface, or concrete cone breakout failure. Steel failure may also occur. The embedment failure mode and strength can be predicted from equations that represent the behavior of each failure mode. The lowest of these predicted strengths indicates the expected failure mode unless this failure mode is prevented by physical constraints of the anchor configuration. For example, failure at the steel/grout interface is not possible if a headed anchor is utilized.

As previously mentioned, equations to predict anchor strength when failure occurs from a concrete cone breakout or at the steel/grout interface have undergone extensive testing. Zamora (1998) proposed using the hole diameter instead of the anchor diameter in the uniform bond stress model to predict anchor strength when failure occurs

at the grout/concrete interface. This substitution was shown previously in Equation (4). Using the failure load obtained from testing, the bond stress, τ_0 , can be calculated.

Anchors in the current test program were designed to exhibit a failure at the grout/concrete interface. It was predicted that the bond strength would correspond to the failure load calculated using the hole diameter in the uniform bond stress model. Therefore, the critical edge distance was expected to be $8d_0$, and the critical spacing between adjacent anchors was anticipated to be $16d_0$ as shown previously in Figure 3-6. However, Figures 8-1 and 8-2 show that the coefficients of 8 and 16 are overly conservative for predicting the mean anchor bond strength for anchors installed near a free edge and in fastener groups, respectively. Figure 8-1 depicts a plot of the normalized anchor strength versus edge distance. To normalize, the test result and the predictive curve were divided by the predicted strength of a single anchor installed away from an edge and surrounding anchors. Figure 8-2 presents a graph of the normalized anchor group strength versus anchor spacing. The test result and predictive curve were divided by four times the predicted strength of a single anchor installed away from an edge and surrounding anchors to normalize. Therefore, the behavior of grouted anchors experiencing a bond failure at the grout/concrete interface can be better represented if the critical edge and spacing distances are revised.

The following sections provide recommended equations and modification factors for determining the design strength of single grouted anchors and groups of grouted fasteners in uncracked concrete using Load and Resistance Factor Design (LRFD).

8.3 Proposed Critical Edge Distance and Critical Anchor Spacing Revision

Different values for the critical edge distance and anchor spacing were considered by graphically fitting design equations to the test data. It was assumed that the critical

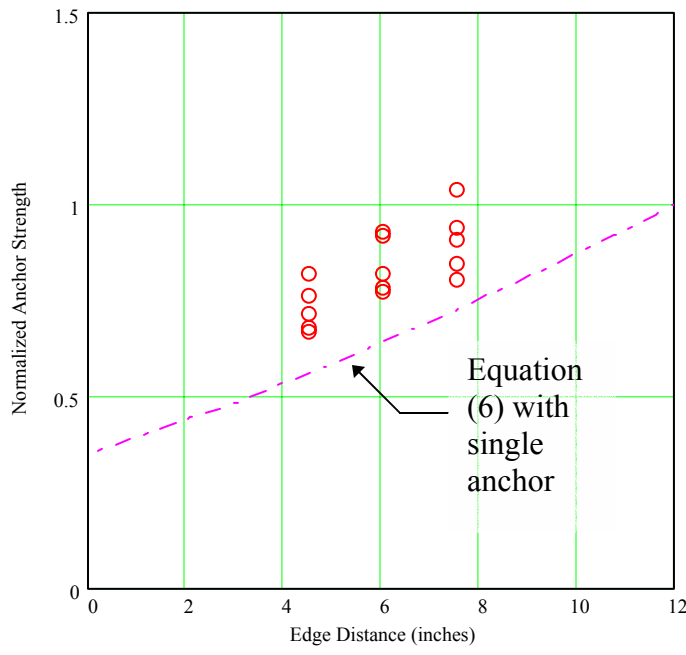

Figure 8-1 Critical edge distance of $8d_0$ compared to experimental results

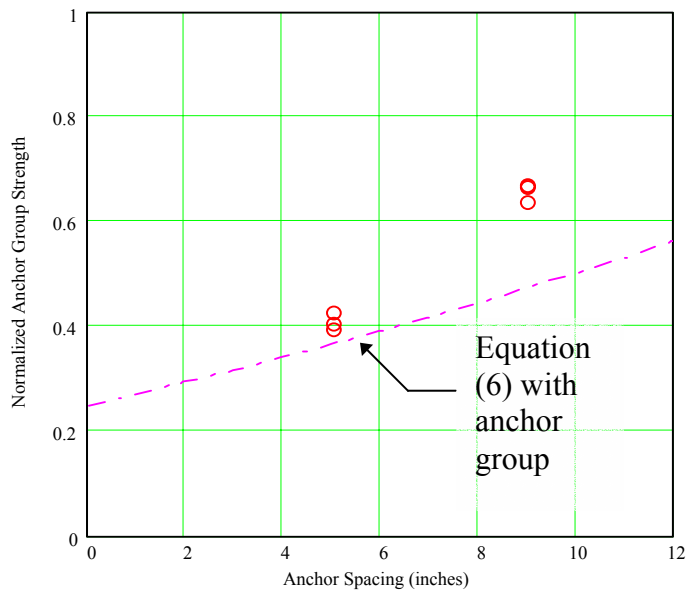

Figure 8-2 Critical anchor spacing of $16d_0$ compared to experimental results
anchor spacing is twice the critical edge distance, similar to the existing uniform bond stress model. The values chosen to best fit the experimental data of the current report's

test program were $5d_0$ for the critical edge distance and $10d_0$ for the critical spacing between anchors. Figures 8-3 and 8-4 display how these new coefficients more accurately predict the mean failure loads obtained during testing and are normalized as discussed in the previous section for Figures 8-1 and 8-2. In Figure 8-4, the proposed equation predicts a higher strength for bond failure at the grout/concrete interface than that found from testing when the anchor spacing equals 5 inches. This was as expected since the failure mode observed during testing was a concrete cone breakout which occurred at a lower load than a failure at the grout/concrete interface.

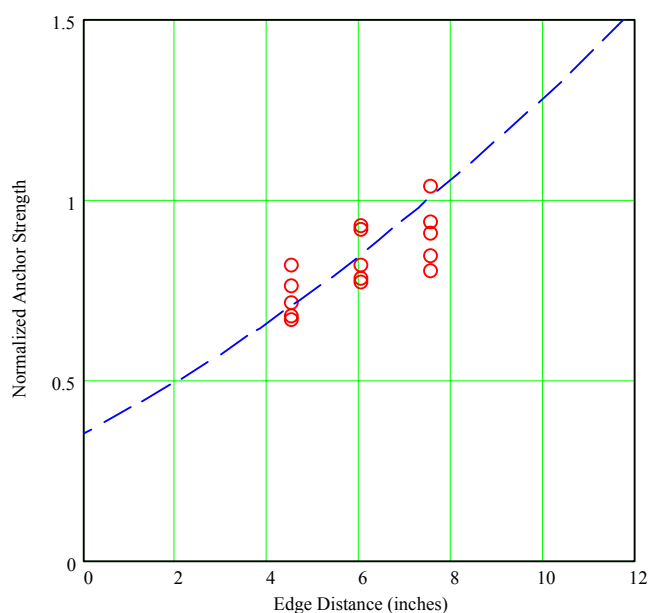

Figure 8-3 Critical edge distance of $5d_0$ compared to experimental results

8.4 Proposed Model for Single Grouted Anchors

For single unheaded grouted anchors, it is recommended that the design strength be taken as the smaller of the bond strengths calculated at the steel/grout interface and at the grout/concrete interface using Equation (9) and Equation (10), respectively. The following design equations are based on the uniform bond stress model and a 5% fractile.

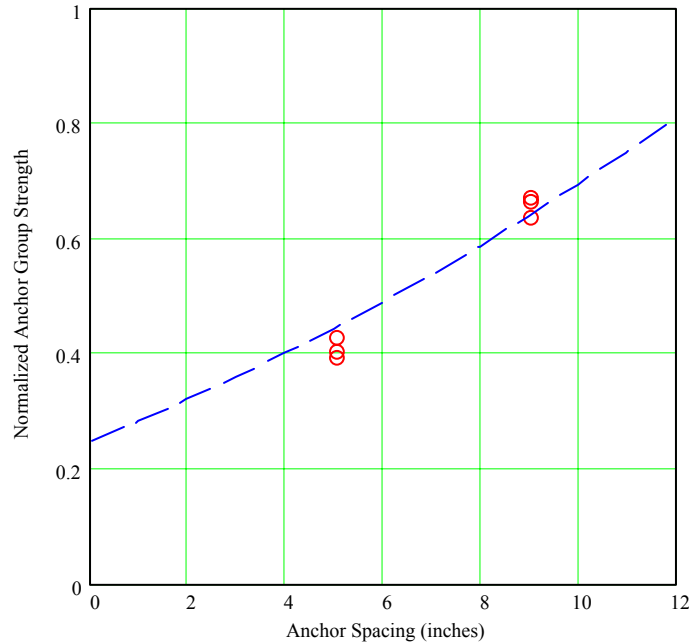

Figure 8-4 Critical anchor spacing of $10d_0$ compared to experimental results

$$\phi_b N'_{\tau,0} = \phi_b (\Psi'_{\tau,e} \tau' \pi d h_{ef}) \quad (\text{lbf or N}) \quad (9)$$

$$\phi_b N'_{\tau_0,0} = \phi_b (\Psi'_{\tau_0,e} \tau'_0 \pi d_0 h_{ef}) \quad (\text{lbf or N}) \quad (10)$$

$$\text{where } \Psi'_{\tau_0,e} = 0.7 + 0.3 \frac{c}{5d_0}$$

For single headed grouted anchors, it is recommended that the design strength be taken as the smaller of the bond strength calculated at the grout/concrete interface and the concrete cone breakout strength using Equations (10) and (11a or 11b), respectively. The following design equations are based on the CCD model and a 5% fractile.

$$\phi_c N'_{c,0} = \phi_c (\Psi'_{c,e} 30 \sqrt{f'_c} h_{ef}^{1.5}) \quad (\text{lbf}) \quad (11a)$$

or

$$\phi_c N'_{c,0} = \phi_c (\Psi_{c,e} 12.6 \sqrt{f'_c} h_{ef}^{1.5}) \quad (\text{N}) \quad (11b)$$

8.5 Proposed Design Model for Grouted Anchor Groups

For groups of unheaded grouted fasteners, it is recommended that the design strength be taken as the smaller of the bond strengths calculated at the steel/grout interface and at the grout/concrete interface using Equations (12) and (13), respectively. The following design equations are based on the uniform bond stress model and a 5% fractile.

$$\phi_b N'_{\tau} = \phi_b \left(\frac{A_N}{A_{N0}} N'_{\tau,0} \right) \quad (\text{lbf or N}) \quad (12)$$

$$\phi_b N'_{\tau_0} = \phi_b \left(\frac{A_N}{A_{N0}} N'_{\tau_0,0} \right) \quad (\text{lbf or N}) \quad (13)$$

For groups of headed grouted anchors, it is recommended that the design strength be taken as the smaller of the bond strength calculated at the grout/concrete interface and the concrete cone breakout strength using Equations (13) and (14), respectively. The following design equation is based on the CCD model and a 5% fractile.

$$\phi_c N'_{cone} = \phi_c \left(\frac{A_N}{A_{N0}} N'_{c,0} \right) \quad (\text{lbf or N}) \quad (14)$$

In Equations (12 and 14), A_N and A_{N0} are calculated as shown in Figures 3-4 and 3-2, respectively. In Equation (13), A_N and A_{N0} are calculated as shown in Figure 3-6 except using a critical edge distance of $5d_0$ and a critical anchor spacing of $10d_0$.

CHAPTER 9
DISCUSSION ON PROPOSED PRODUCT APPROVAL TESTS

9.1 General

A good grout product will possess the following desirable qualities:

- flowability for ease of placement and sufficient working time
- low sensitivity to hole drilling technique
- low sensitivity to hole cleaning technique
- low sensitivity to moisture condition of hole
- low sensitivity to temperature differentials
- rapid development of bond strength
- consistent bond strength when installed using various types of anchors

Currently, the FDOT has working technical documents for installation, performance standards, and anchor system tests for adhesive anchors and dowels. At this time, no such documents exist for grouted anchors. Proposed revisions to FDOT Section 416, FDOT Section 937, and FM 5-568 to include grouted anchors are presented in Appendices G, H, and I.

The following sections present the proposed product approval tests to evaluate engineered grout products. In all of the following, the maximum coefficient of variation is limited to 20% unless otherwise stated by the Engineer for the given application. This is similar to the aforementioned limit placed on the coefficient of variation for uniform bond stress in FDOT Section 937 (FDOT 2002a) for adhesives. As mentioned in Section

7.3, the level that constitutes a significant change in bond strength is 20% for the purposes of this report. Additionally, in all sections a minimum of five repetitions should be performed in accordance with ASTM E 488 (ASTM 2001d). When only steel failure occurs, ASTM E 488 requires a minimum of three repetitions.

9.2 Grout/Concrete Bond Stress (τ_θ)

This proposed product approval test allows the grout/concrete bond stress (τ_θ) to be determined for a given grout product. This value can be calculated from the anchor strength if a bond failure occurs at the grout/concrete interface. Failure at the grout/concrete interface is a failure mode that occurs infrequently, but test parameters can be configured to force this failure mode to occur. This failure mode can be achieved by using a headed anchor to preclude failure at the steel/grout interface and minimizing the hole diameter. Additionally, a bond failure at the grout/concrete interface can be achieved by using a higher strength concrete such that the tensile capacity associated with a grout/concrete bond failure will be less than the breakout capacity of the concrete. All anchors shall be installed per manufacturer instructions using a 0.75 inch diameter anchor headed with a heavy hex nut and installed in a 1.5 inch diameter hole with an embedment length of 5 inches measured from the top of the nut. Once τ_θ is determined for a grout product, it can be used in calculations for predicting the strength of various anchor configurations such as edge distance and group tests.

9.3 Test Series to Establish Steel/Grout Bond Stress (τ)

This test series allows the steel/grout bond stress (τ) to be determined for a given grout product. This value can be calculated from the bond strength if a failure is forced at the steel/grout interface. This failure mode can be initiated by using unheaded anchors

installed in concrete whose breakout capacity is greater than the bond capacity of the grout product. All anchors shall be installed in accordance with the manufacturer's instructions and as unheaded to promote a failure at the steel/grout interface. All anchors shall be installed per manufacturer instructions using a 0.75 inch diameter unheaded anchor installed in with an embedment length of 5 inches measured from the base of the anchor. Once τ has been determined for a grout product, it can be used in subsequent strength prediction calculations.

9.4 Strength versus Curing Time

In certain scenarios, it may be necessary for an anchor to sustain loading a short time after installation. It is advantageous to know when a product develops sufficient strength so that premature loading, and the resulting problems, may be avoided. In the same vein, construction time may be saved if it is known that a particular grout product achieves sufficient strength in a short amount of time.

Anchors shall be installed according to manufacturer directions and as unheaded. Polymer grouted and quick setting cementitious grouted anchors should be tested at 24 hours and 7 days. Non-quick setting cementitious grouted anchors should be tested at 7 days and 28 days. A minimum of five anchors should be tested at each interval. The interval at which the bond strength reaches a sufficient value should be noted. This knowledge can be used in construction scheduling as well as in choosing a grout product whose strength development fits into a given time frame.

9.5 Threaded Rod versus Deformed Reinforcing Bar

It is important to compare the bond strength a grout product possesses for threaded rods and deformed reinforcing bars. Both of these materials are commonly installed in the field, so being able to predict how they will behave while in-service is

imperative. This test program should investigate the performance of unheaded grouted anchors installed with a threaded rod and compare this behavior to that when a deformed reinforcing bar is installed. Installation using a threaded rod shall be considered as the baseline series. Unheaded anchors must be used to try to force a failure at the steel/grout interface. A failure at this location will allow calculation of the bond stress, τ , directly from the bond strength.

All anchors shall be installed in accordance with the manufacturer's directions and as unheaded. The resulting bond strengths should be compared. Ideally, the grout product would exhibit similar bond strengths for both types of anchors. The results from testing of threaded rods and reinforcing bars should be compared. If the deformed reinforcing bar average bond strength is more than 20% less than the average bond strength of threaded rods, or if the coefficient of variation of the deformed reinforcing bar test series exceeds the aforementioned maximum, the grout product should be limited to installation with threaded rods.

9.6 Hole Drilling Technique

Anchor test series should include the baseline series of installing headed anchors in core-drilled holes as well as a series of headed anchors in holes drilled with the hole drilling technique to be evaluated. In order to evaluate the effect of the hole drilling technique, a bond failure at the grout/concrete interface must occur. Therefore, all anchors shall be installed using the type of nut, anchor diameter, hole diameter, and embedment depth described in Section 9.2. If either the coefficient of variation for the tested hole drilling technique or the reduction in the bond strength between the baseline and the variable test series exceed the limit of 20%, the grout product tested should not be installed in holes drilled using the tested hole drilling technique.

9.7 Moisture Condition of Hole

Bond strength can be influenced by the moisture condition of the hole depending on the type of grout product used for anchor installation. Cementitious grout products commonly require installation in damp holes to prevent excessive water loss from the grout to the concrete, which could reduce the bond strength of the grout. Polymer grouts are usually installed in dry holes to allow the chemical reactions to occur, thus binding the grout to the concrete. If a polymer grouted anchor is installed in a damp hole (i.e. a core-drilled hole that has not been given sufficient time to dry), the presence of water could impede the bonding process, thus reducing the bond strength. Grout products being evaluated should be tested for sensitivity to damp or dry hole conditions. In order to evaluate the effect of the moisture condition of the hole, it is necessary for failure to occur at the grout/concrete interface. Therefore, all anchors shall be installed using the type of nut, anchor diameter, hole diameter, and embedment depth described in Section 9.2.

In the damp hole installation test series, polymer grouted anchors should be installed as headed and according to the manufacturer's instructions, except the holes shall be damp at the time of installation as described in Section 5.3. Additionally, a baseline series needs to be installed as per manufacturer instructions. The bond strength from the baseline series and the damp hole installation series should be compared. ICBO ES AC58 (ICBO ES 2001) states that all dampness specimen results shall be at least 80% of the average of the baseline specimens. The appropriate restrictions, if any, should be assigned to the polymer grout product based on the bond strength results evaluated in accordance with ICBO ES AC58 and the maximum coefficient of variation as set forth in this report.

In the dry hole installation test series, cementitious grouted anchors should be installed in accordance with the manufacturer's instructions, except the holes shall be dry at the time of installation. Additionally, a baseline series needs to be installed per manufacturer instructions. The bond strength from the baseline series and the dry hole installation series should be compared. Dry specimen shall be considered in a similar manner to dampness specimen. All dry hole installation specimen results shall be at least 80% of the average of the baseline series. The coefficient of variation of the dry hole installation series shall be less than the aforementioned maximum. The appropriate restrictions, if any, should be assigned to the cementitious grout product based on the bond strength results.

9.8 Elevated Temperature

This parameter is considered more critical for polymer grouts as they are believed to be more sensitive to temperature changes. Test series of headed and unheaded anchors installed, cured, and tested at elevated temperature (110° F; 43.3° C) should be performed. The anchors should be installed in accordance with the manufacturer's directions, except at elevated temperature. The bond strengths from each series should then be compared. The grout product may be approved for use in elevated temperature applications if the average bond strength at elevated temperature is not more than 20% less than the bond strength of the baseline series and the coefficient of variation of the elevated temperature series is less than the limit set forth in this report.

9.9 Horizontal and Overhead Hole Orientation (Optional)

Bond strength has the potential to be significantly reduced when anchors are installed at an orientation other than vertically downward. This reduction is due to the grout settling unevenly or flowing out of the hole. For a horizontal installation, the

anchor is perpendicular to the vertical face of the concrete. The anchor potentially settles against the lower surface of the hole resulting in a non-uniform grout thickness around the anchor. Additionally, air voids can form along the upper hole surface. This diminishes the bond area and thus results in a corresponding reduction in bond strength.

For an overhead orientation, the anchor is installed vertically upward. The grout wants to flow out of the hole, and the anchor potentially settles in an outward movement. This settlement can result in a reduction in the effective embedment depth and corresponding losses of bond area and bond strength.

In order to minimize the punitive effects an alternate hole orientation can have on bond strength, it is highly recommended that cementitious grouts should not be installed in this type of application. Non-quick setting cementitious grouts are not sufficiently viscous, and their initial set time is too long to make their use practical for alternate hole orientation installations. Similarly, polymer grouts possessing low viscosities should also not be utilized.

In the optional horizontal hole orientation test series, grouted anchors shall be installed in accordance with manufacturer directions, except in horizontally oriented holes. The bond strength from the baseline series installed in vertical holes and horizontal hole orientation series should be compared. If the bond strength is reduced by more than the limit set forth in this report when installed horizontally, or if the coefficient of the horizontal hole test series exceeds the aforementioned maximum, the grout product shall be excluded from installation in horizontally oriented holes.

Similar optional tests to those performed on anchors in the horizontal hole orientation test series should be performed on grouted anchors installed in overhead

holes. This test series should also be compared to the baseline series. Similarly, if the reduction in bond strength or the coefficient of variation of the overhead test series exceed the limits set forth in this report, the grout product shall be excluded from use in this application.

9.10 Long-term Load (Optional)

Anchors subjected to sustained tension loading may undergo displacements due to creep. If the rate of displacement does not attenuate, the anchor displacement will reach unacceptable levels. The variable of interest is the amount of displacement. Therefore, the applied load should not induce failure. The applied load should be a service level load that can be taken as a percentage of the tensile load that incites failure. Similar to FM 5-568 (FDOT 2000), it is recommended that a tensile load that is 40% of the mean failure load value from the baseline series be used.

This test series is optional unless sustained long-term load is anticipated. Both headed and unheaded anchors shall be tested. In these test series, anchors should be installed per the manufacturer's directions. In accordance with FM 5-568, creep tests shall be performed at elevated temperature.

Displacements should be measured more frequently near the beginning of the loading period. It is recommended that displacement data should be sampled for a minimum of 42 days. At the end of 42 days, the load can be removed from the anchors. In accordance with FDOT Section 937 (FDOT 2002a), the rate of displacement shall decrease during the 42 day loading period. Also, at the end of the loading period, the total creep displacement shall be less than 0.03 inch (0.75 mm) and less than 0.003 inch (0.075 mm) during the last 14 days of loading.

The anchors that have not exceeded the predefined displacement limit should then be reloaded in tension and tested to failure. The bond strength from these reloaded anchors should be compared to that of the baseline test series. If the coefficient of variation or the reduction in bond strength of the creep test series exceed the limits set forth in this report, it may be appropriate to limit the use of the product to applications in which service loads would not need to be sustained long-term. If the level of creep displacement exceeds the limit, the anchor can be considered to have failed.

9.11 Additional Factors

Other factors may also need to be considered when determining whether a grout product can be used in a certain application. Some additional factors are: repeated loads, freezing and thawing cycles, seismic (shear and tension), cracked concrete, and concrete aggregate. Testing methods for these factors are outside the scope of this report.

CHAPTER 10 SUMMARY, CONCLUSIONS, AND RECOMMENDATIONS

10.1 Summary

This report addresses the behavior of headed and unheaded grouted anchors tested in tension. Data from this test program as well as a summary of data from other test programs are presented. A variety of products, anchor configurations, installation conditions, edge distances, and group anchor spacings have been tested. The anchors tested in this and the other test programs were installed in uncracked concrete test specimens. The performance of grouted anchors in cracked concrete was not included in this project. Test results were used to establish if existing behavioral models for adhesive and cast-in-place anchors could be extended to accurately predict the strength of grouted anchors. These models are the uniform bond stress model and the concrete capacity design model, respectively. Additionally, factors that constitute a desirable grout product are discussed. The results from various installation and service condition tests are analyzed, and product approval tests for grouts are proposed.

10.2 Conclusions

Grouted anchor behavior varies depending on the product used for installation, whether the anchor is installed as unheaded or headed, installed near an edge, installed in an anchor group, and what installation and service conditions the anchor is exposed to. Four different failure modes exist for grouted anchors: bond failure at the steel/grout interface, bond failure at the grout/concrete interface, concrete breakout failure, and steel failure. Assuming steel failure does not control, unheaded grouted anchors predominantly experience a bond failure at the steel/grout interface, but a bond failure at the grout/concrete interface has also been observed. Again, assuming steel failure does

not control, headed grouted anchors may experience either a bond failure at the grout/concrete interface or a concrete cone breakout.

In general, the capacity of unheaded grouted anchors can be predicted by the uniform bond stress model (Equations (3) and (5)), which is based on the bond stress (τ) at the steel/grout interface. If the grout/concrete bond stress (τ_0) is low enough, a bond failure may occur at the grout concrete interface (Equations (4) and (6)). The failure mode can be predicted based on which equation yields the smaller bond strength. For design, the expected anchor strength can be taken as the lesser of Equation (9) and Equation (10).

Bond failure at the steel/grout interface is precluded for headed grouted anchors by the presence of the head. The capacity of headed grouted anchors can be predicted by either the uniform bond stress model (Equations (4) and (6)) or the concrete capacity design model (Equations (1a or 1b) and (2)). The failure mode can be predicted by which of these two models yields the lower result. For design, the expected anchor strength can be taken as the lesser of Equation (10) and Equations (11a or 11b).

The test program reported in this report indicated that the critical edge distance and critical anchor spacing of the uniform bond stress model currently used for adhesive anchors ($8d$ for critical edge and $16d$ for critical spacing) is valid for the steel/grout bond failure mode but not for the grout/concrete bond failure mode. The data were analyzed, and the critical edge distance for grouted anchors exhibiting a grout/concrete bond failure was found to be $5d_0$; the critical anchor spacing for grouted anchors was found to be $10d_0$.

This report includes an analysis of tests of installation and service conditions.

The tests performed in the current test program and in previous testing programs led to the following conclusions:

- Products develop strength at different rates. In general, polymer grouts develop a significant portion of strength more rapidly than cementitious grouts.
- The type of grout product used to install the anchor can greatly influence the anchor strength. Unheaded smooth rods should not be relied upon in tension.
- Headed grouted anchors are not sensitive to the type of nut (regular hex or heavy hex) used on the embedded end during installation.
- The moisture condition of the hole affects the bond strength of anchors installed with polymer grouts, and it is conjectured that cementitious grouts can also be sensitive to the moisture condition of the hole.
- Polymer grouts are believed to be sensitive to elevated temperatures since they are similar in composition to adhesives, which have been shown to possess this sensitivity.

10.3 Recommendations

Based on the test results presented in this report, the following tests are proposed to establish grout product properties and sensitivities:

- Establish τ_0 .
- Establish τ .
- Establish strength development curve.
- Compare threaded rod versus deformed reinforcing bar.
- Evaluate sensitivity to hole drilling technique.

- Evaluate sensitivity to moisture condition of hole.
- Evaluate sensitivity to elevated temperature.

Additionally, hole orientation and long-term loading (creep) tests are proposed as optional tests.

A comprehensive design model for grouted anchors is needed, and the CCD method and modifications to the uniform bond stress model were shown to accurately predict anchor capacity. It was observed that installation and service conditions will affect the behavior of grouted anchors, and product approval tests were proposed to investigate some of these effects. Further testing is recommended to establish safety factors for the aforementioned installation and service conditions. Future study is recommended for the following topics not addressed in this report:

- The effect of repeated loads on the performance of grouted anchors.
- The effect of freezing and thawing cycles on the performance of grouted anchors.
- The effects of seismic forces (shear and tension) on the performance of grouted anchors.
- The effect of cracked concrete members on the performance of grouted anchors.
- The effect of various concrete aggregates on the performance of grouted anchors.

APPENDIX A
NOTATION

- c = distance from center of an anchor shaft to the edge of concrete, in (mm).
- c_1 = distance from the center of an anchor shaft to the edge of concrete in one direction, in (mm).
- c_2 = distance from the center of an anchor shaft to the edge of concrete in the direction orthogonal to c_1 , in (mm).
- d = diameter of the anchor, in (mm).
- d_0 = diameter of the hole, in (mm).
- d_i = net potentiometer displacement; subscript ranges from 1 to 4 for quadruple fastener anchor groups, in (mm).
- d_n = distance from the surface of the concrete to the bottom of the pull plate at each anchor in an anchor group; subscript ranges from 1 to 4 for quadruple fastener anchor groups, in (mm).
- $d_{n,poten}$ = distance from the surface of the concrete to the bottom of the pull plate at each potentiometer in an anchor group; subscript ranges from 1 to 4 for quadruple fastener anchor groups, in (mm).
- d_{tot} = overall displacement of an anchor group, in (mm).
- f'_c = concrete compressive strength, psi (N/mm^2).
- h_{ef} = effective anchor embedment depth, in (mm).
- k = factor based on a 5% fractile, 90% confidence, and number of tests performed.
- n = number of tests performed.
- s = anchor center-to-center spacing, in (mm).
- s_1 = anchor center-to-center spacing in one direction, in (mm).

- s_2 = anchor center-to-center spacing in the direction orthogonal to s_1 , in (mm).
- A_{bond} = bonded surface area between grout and concrete, in² (mm²).
- A_N = projected concrete failure area of an anchor or group of anchors, for calculation of strength in tension, in² (mm²).
- A_{N0} = projected concrete failure area of one anchor, for calculation of strength in tension when not limited by edge distance or spacing, in² (mm²).
- N = general mean tensile strength for an anchor group with unspecified failure mode, lbf (N).
- N_0 = general mean tensile strength for a single anchor with unspecified failure mode, lbf (N).
- $N_{c,0}$ = mean tensile strength for concrete cone breakout of a single anchor, lbf (N).
- $N_{\tau,0}$ = mean tensile strength for steel/grout failure of a single anchor, lbf (N).
- $N_{\pi,0}$ = mean tensile strength for grout/concrete failure of a single anchor, lbf (N).
- N_c = mean tensile strength for concrete cone breakout of an anchor group, lbf (N).
- N_{test} = tensile strength of a single anchor or an anchor group for one test repetition, lbf (N).
- N_{τ} = mean tensile strength for steel/grout failure of an anchor group, lbf (N).
- N_{π} = mean tensile strength for grout/concrete failure of an anchor group, lbf (N).
- $N'_{c,0}$ = nominal tensile strength for concrete cone breakout of a single anchor, lbf (N).
- $N'_{\tau,0}$ = nominal tensile strength for steel/grout failure of a single anchor, lbf (N).
- $N'_{\pi,0}$ = nominal tensile strength for grout/concrete failure of a single anchor, lbf (N).
- N'_{cone} = nominal tensile strength for concrete cone breakout of an anchor group, lbf (N).
- N'_{τ} = nominal tensile strength for steel/grout failure of an anchor group, lbf (N).
- N'_{π} = nominal tensile strength for grout/concrete failure of an anchor group, lbf (N).
- COV = coefficient of variation.

- ϕ_b = strength reduction factor for bond failure (0.85 is recommended).
- ϕ_c = strength reduction factor for concrete cone breakout (0.75 is recommended).
- τ = mean uniform bond stress at the steel/grout interface, psi (MPa).
- τ_0 = mean uniform bond stress at the grout/concrete interface, psi (MPa).
- $\tau_{0,test}$ = uniform bond stress at the grout/concrete interface for a single anchor or an anchor group in one test repetition, psi (MPa).
- τ' = $\tau(1-kCOV)$, nominal uniform bond stress at the steel/grout interface, psi (MPa).
- τ'_0 = $\tau_0(1-kCOV)$, nominal uniform bond stress at the grout/concrete interface, psi (MPa).
- $\Psi_{\tau,e}$ = modification factor, for strength in tension, to account for edge distances when bond failure occurs at the steel/grout interface.
- $\Psi_{\tau_0,e}$ = modification factor, for strength in tension, to account for edge distances when bond failure occurs at the grout/concrete interface.
- $\Psi_{c,e}$ = modification factor, for strength in tension, to account for edge distances when concrete cone breakout failure occurs.

APPENDIX B
TENSILE LOAD VS. DISPLACEMENT GRAPHS FOR BASELINE AND HOLE
DRILLING TECHNIQUE TEST SERIES

Single anchor test designation is as follows:

CD 1-2

Where:

“CD”: First two letters specify the type of hole drilled

CD – Core-drilled

HD – Hammer-drilled

“1”: First number identifies the test series of the hole type

“2”: Second number identifies the individual anchor in a series

1 – First anchor of the series

2 – Second anchor of the series

3 – Third anchor of the series

4 – Fourth anchor of the series

5 – Fifth anchor of the series

Table B-1 Individual baseline and hole drilling technique anchor test results

Installation #	Tested Effect	Anchor in Series	f'_c at test psi (MPa)	Failure Mode	N_{test} kips (kN)	$\tau_{0,test}$ psi (MPa)
1	Baseline	1	6600 (45.5)	g/c	27.6 (123)	1170 (8.07)
1	Baseline	2	6600 (45.5)	g/c	30.2 (134)	1280 (8.84)
1	Baseline	3	6680 (46.1)	g/c	28.67 (127)	1220 (8.39)
1	Baseline	4	6680 (46.1)	g/c	29.2 (130)	1240 (8.54)
1	Baseline	5	6680 (46.1)	g/c	31.1 (138)	1320 (9.09)
1	Hammer	1	6600 (45.5)	g/c	30.0 (134)	1280 (8.79)
1	Hammer	2	6600 (45.5)	steel	26.1 (116)	NA
1	Hammer	3	6680 (46.1)	g/c	30.6 (136)	1300 (8.94)
1	Hammer	4	6680 (46.1)	steel	24.4 (109)	NA
1	Hammer	5	6680 (46.1)	steel	24.1 (107)	NA
2	Baseline	1	7200 (49.6)	g/c	35.8 (159)	1520 (10.5)
2	Baseline	2	7200 (49.6)	g/c	36.1 (160)	1530 (10.6)
2	Baseline	3	7200 (49.6)	g/c	33.5 (149)	1420 (9.80)
2	Hammer	1	7200 (49.6)	g/c	38.9 (173)	1650 (11.4)
2	Hammer	2	7200 (49.6)	g/c	20.0 (89.2)	851 (5.86)
2	Hammer	3	7200 (49.6)	g/c	28.0 (125)	1190 (8.19)
3	Baseline	1	7330 (50.5)	g/c	41.7 (186)	1770 (12.2)
3	Baseline	2	7330 (50.5)	g/c	41.3 (184)	1750 (12.1)
3	Baseline	3	7330 (50.5)	g/c	34.9 (155)	1480 (10.2)

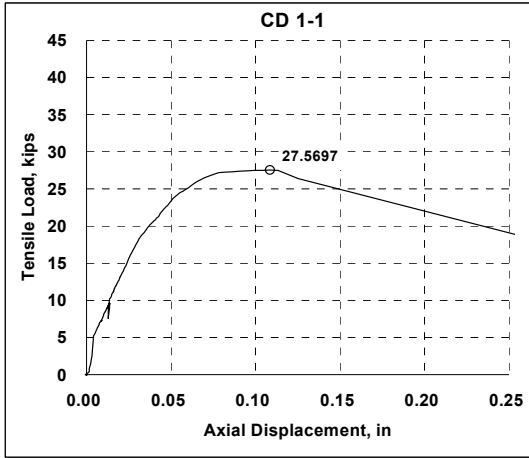

A)

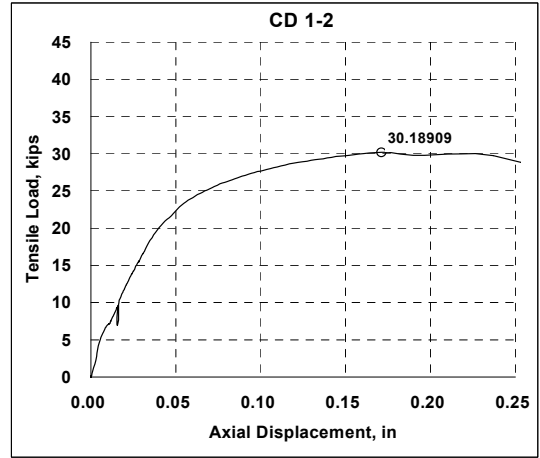

B)

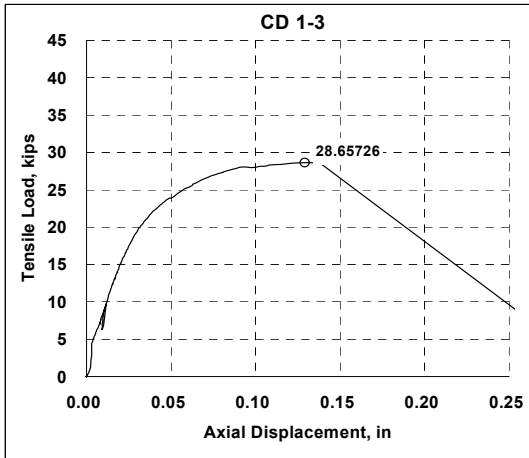

C)

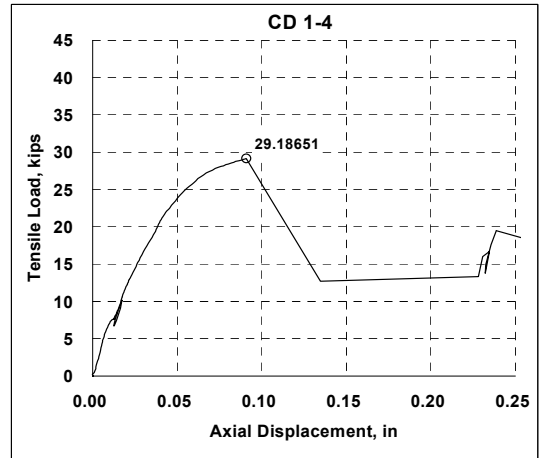

D)

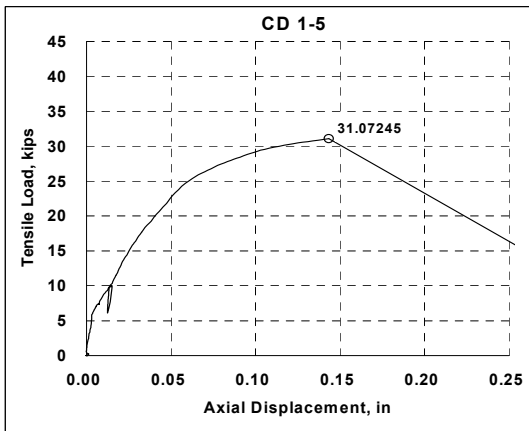

E)

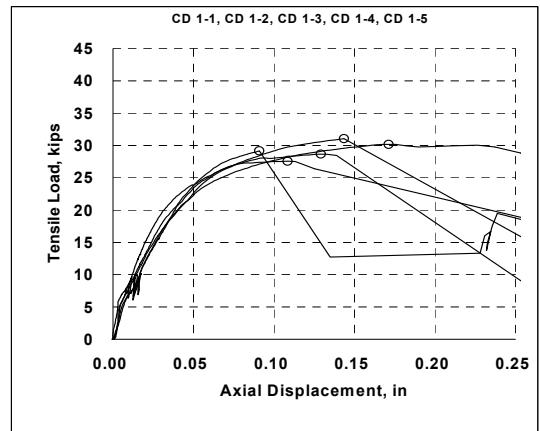

F)

Figure B-1 Graphs of test results of first installation of core-drilled anchors A) First test in series; B) Second test in series; C) Third test in series; D) Fourth test in series; E) Fifth test in series; F) Comparison of all test in series

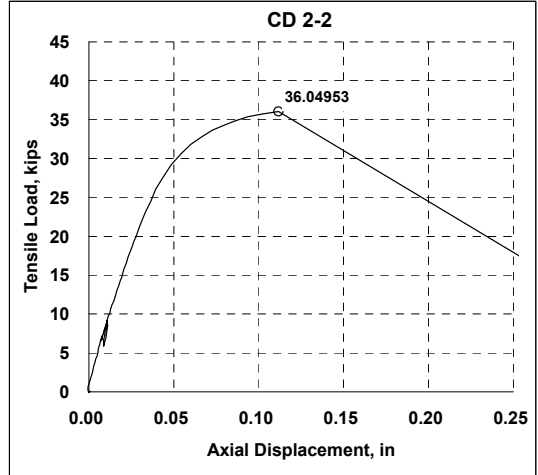
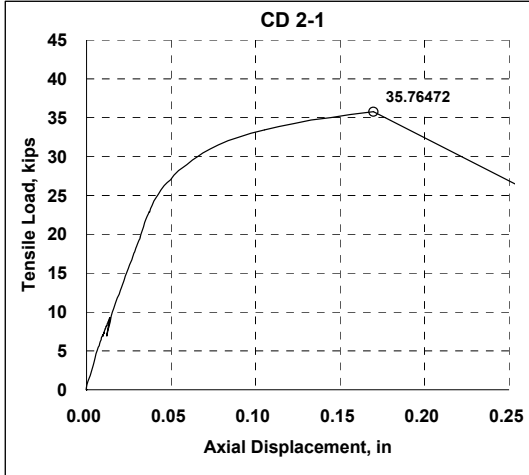

A)

B)

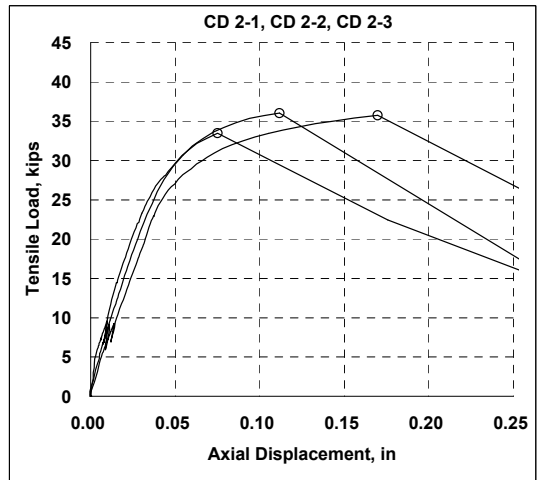
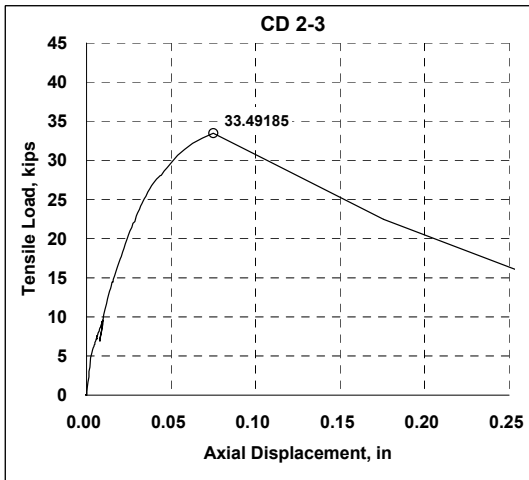

C)

D)

Figure B-2 Graphs of test results of second installation of core-drilled anchors A) First test in series; B) Second test in series; C) Third test in series; D) Comparison of all test in series

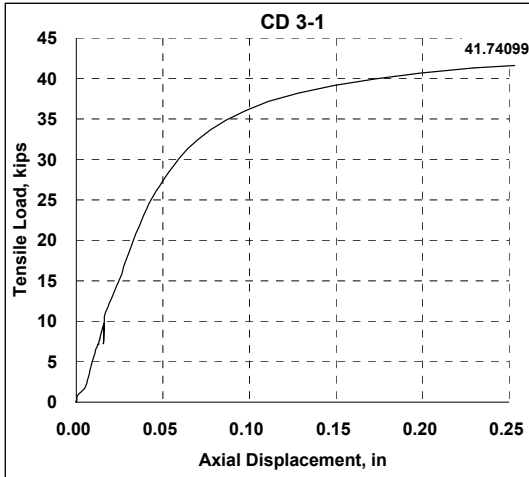

A)

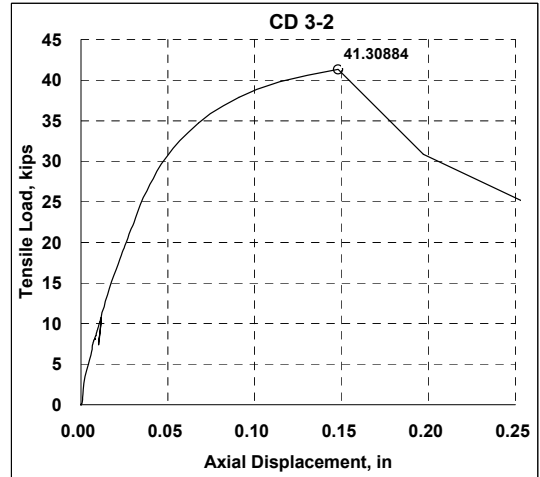

B)

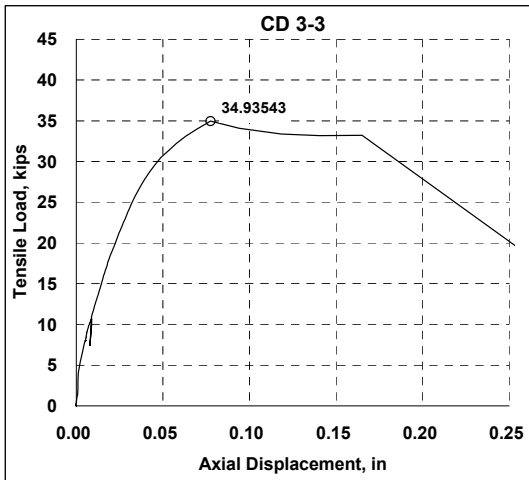

C)

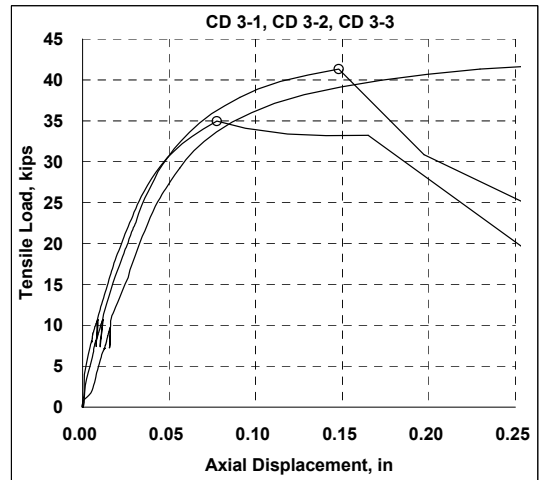

D)

Figure B-3 Graphs of test results of third installation of core-drilled anchors A) First test in series; B) Second test in series; C) Third test in series; D) Comparison of all test in series

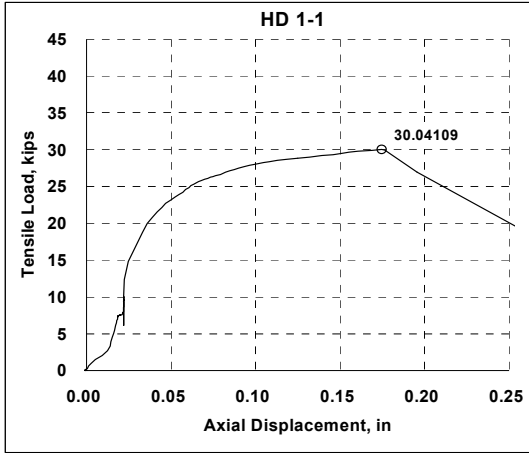

A)

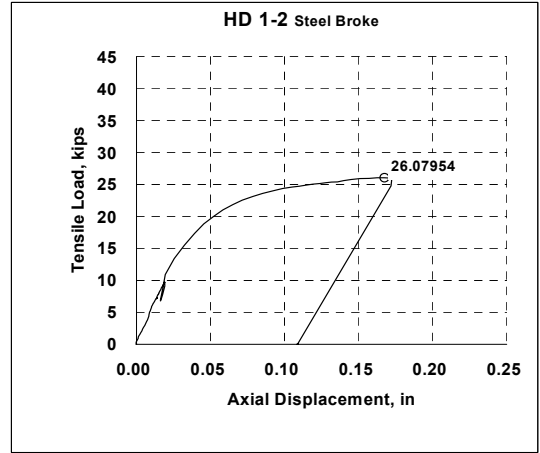

B)

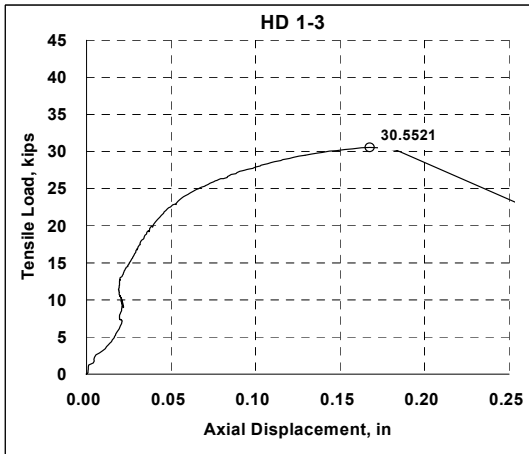

C)

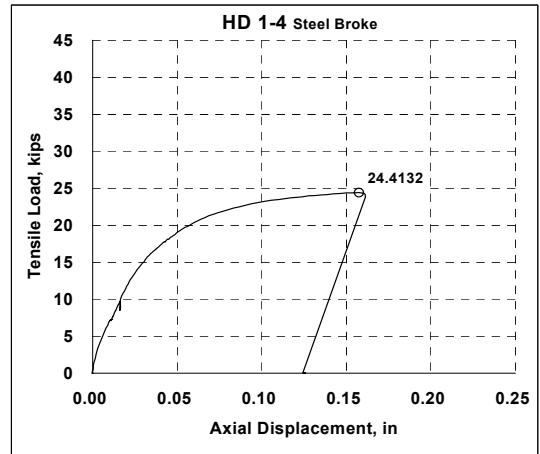

D)

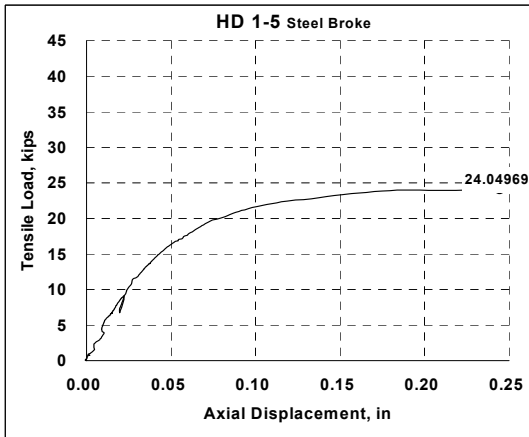

E)

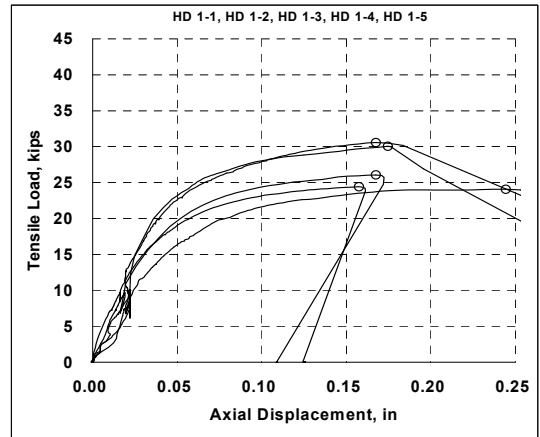

F)

Figure B-4 Graphs of test results of first installation of hammer-drilled anchors A) First test in series; B) Second test in series; C) Third test in series; D) Fourth test in series; E) Fifth test in series; F) Comparison of all test in series

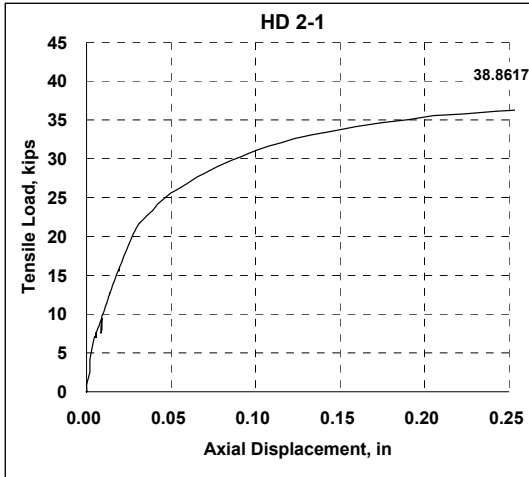

A)

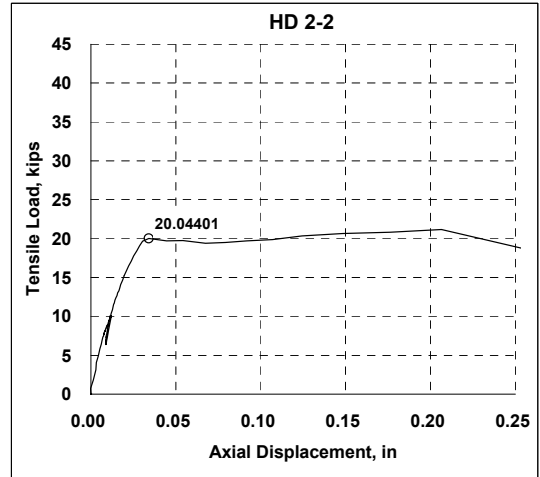

B)

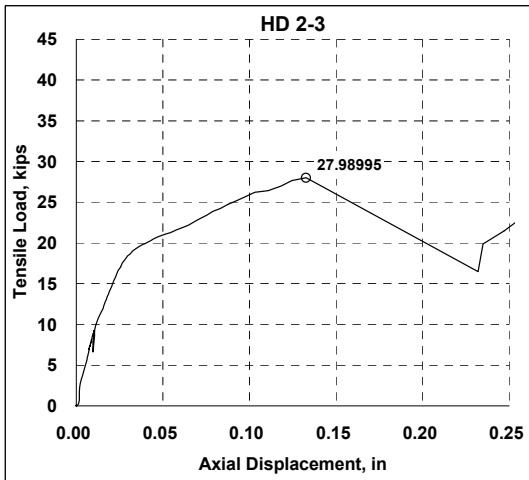

C)

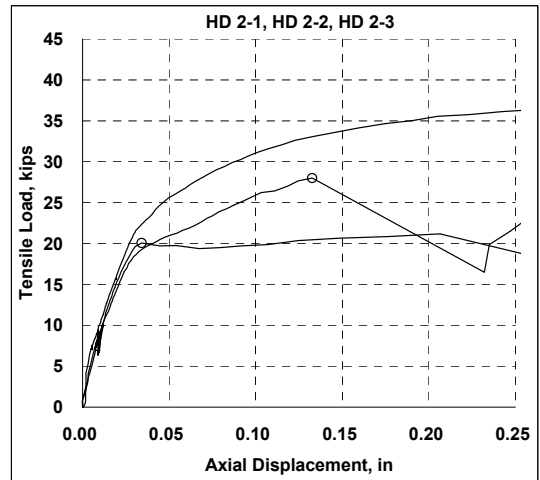

D)

Figure B-5 Graphs of test results of second installation of hammer-drilled anchors
 A) First test in series; B) Second test in series; C) Third test in series; D) Comparison of all test in series

APPENDIX C
TENSILE LOAD VS. DISPLACEMENT GRAPHS FOR EDGE DISTANCE TEST
SERIES

Single edge distance anchor test designation is as follows:

E 4.5-1

Where:

“E”: First letter specifies the test parameter
E – Edge distance test

“4.5”: First number identifies the edge distance of the test series

“1”: Second number identifies the individual anchor in a series
1 – First anchor of the series
2 – Second anchor of the series
3 – Third anchor of the series
4 – Fourth anchor of the series
5 – Fifth anchor of the series

Table C-1 Individual edge distance anchor test results

Installation #	Tested Effect	Anchor in Series	f'_c at test psi (MPa)	Failure Mode	N_{test} kips (kN)	$\tau_{0,test}$ psi (MPa)
2	Edge 7.5	1	6460 (44.5)	g/c	29.7 (132)	1260 (8.70)
2	Edge 7.5	2	6460 (44.5)	g/c	31.95 (142.14)	1360 (9.35)
2	Edge 7.5	3	6460 (44.5)	g/c	36.5 (162)	1550 (10.7)
2	Edge 7.5	4	6460 (44.5)	g/c	33.1 (147)	1400 (9.67)
2	Edge 7.5	5	6460 (44.5)	g/c	28.3 (126)	1200 (8.29)
3	Edge 4.5	1	7600 (52.4)	g/c	32.2 (143)	1370 (9.42)
3	Edge 4.5	2	7600 (52.4)	g/c	28.2 (126)	1200 (8.26)
3	Edge 4.5	3	7600 (52.4)	g/c	30.1 (134)	1280 (8.80)
3	Edge 4.5	4	7600 (52.4)	g/c	26.7 (119)	1130 (7.81)
3	Edge 4.5	5	7600 (52.4)	g/c	26.3 (117)	1110 (7.68)
3	Edge 6.0	1	7330 (50.5)	g/c	36.2 (161)	1540 (10.6)
3	Edge 6.0	2	7330 (50.5)	g/c	30.9 (137)	1310 (9.04)
3	Edge 6.0	3	7330 (50.5)	g/c	32.6 (145)	1390 (9.55)
3	Edge 6.0	4	7330 (50.5)	g/c	32.3 (144)	1370 (9.45)
3	Edge 6.0	5	7330 (50.5)	g/c	30.4 (135)	1290 (8.90)

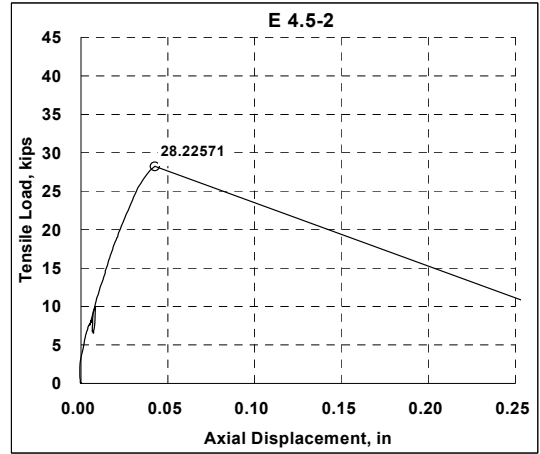
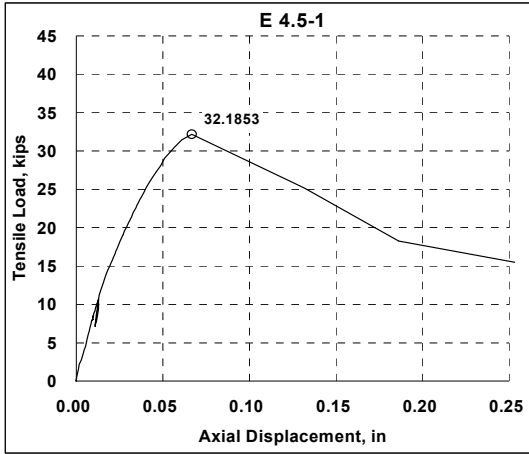

A)

B)

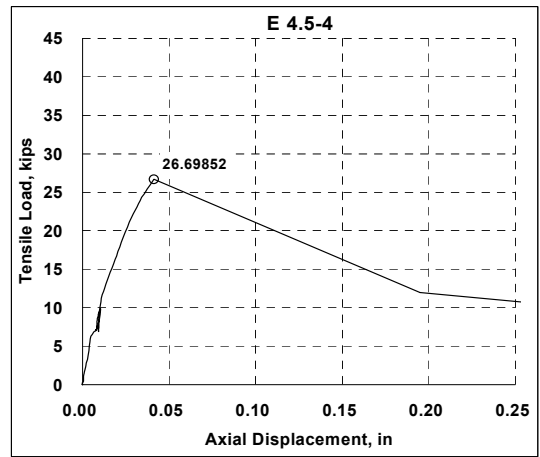
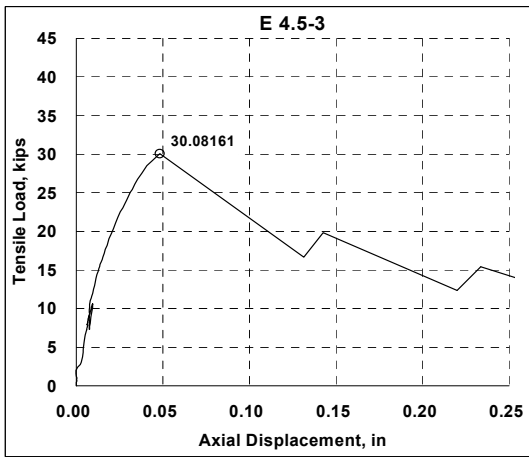

C)

D)

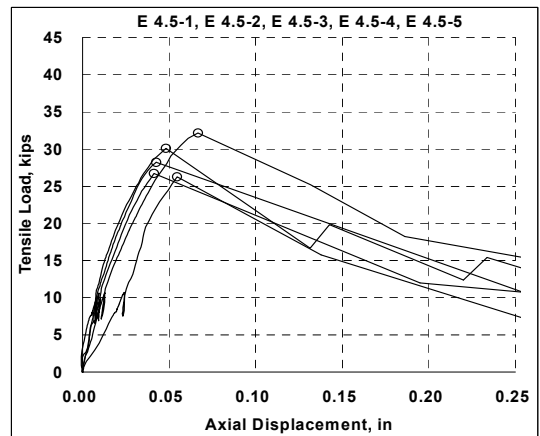
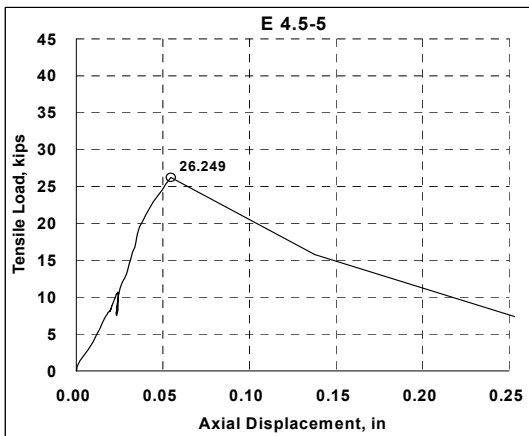

E)

F)

Figure C-1 Graphs of test results of core-drilled anchors installed 4.5 inches away from one edge A) First test in series; B) Second test in series; C) Third test in series; D) Fourth test in series; E) Fifth test in series; F) Comparison of all test in series

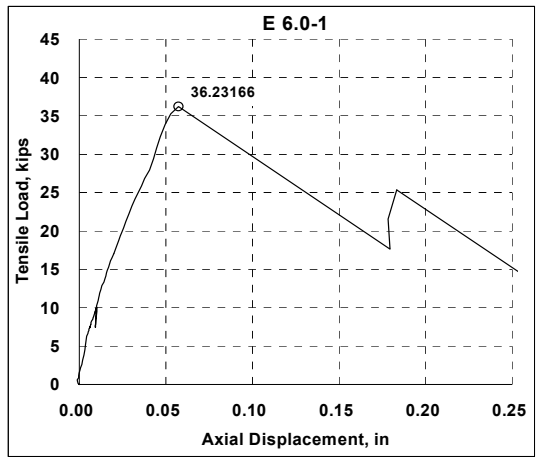

A)

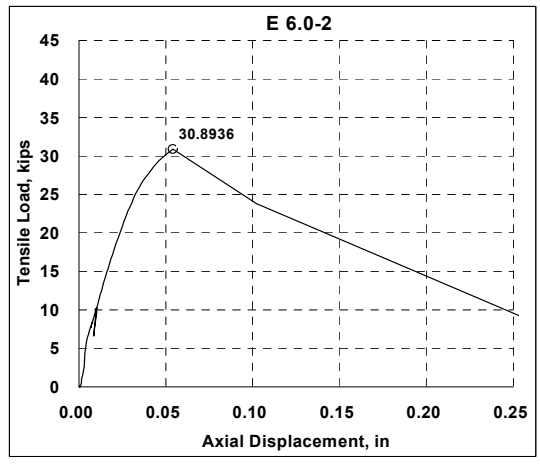

B)

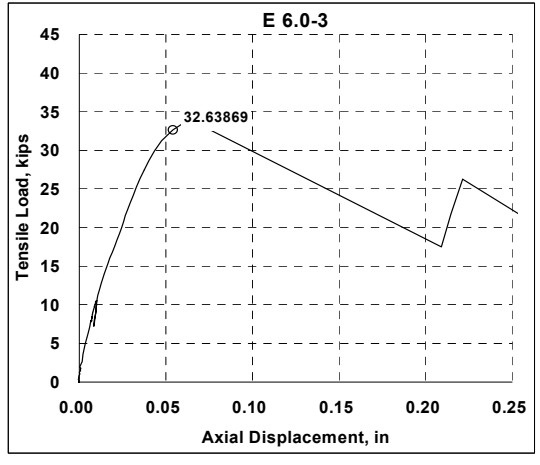

C)

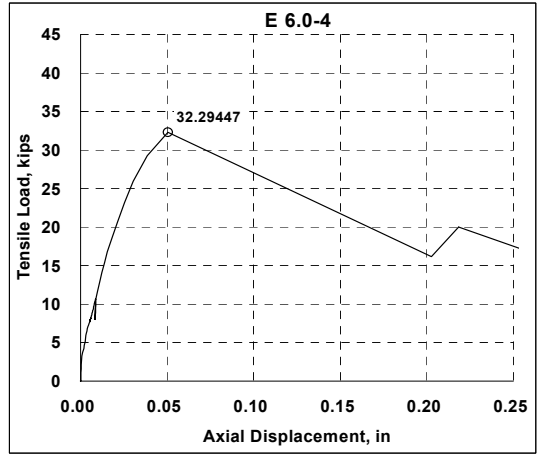

D)

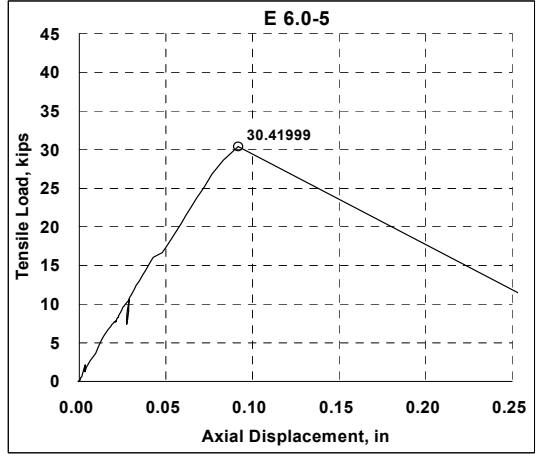

E)

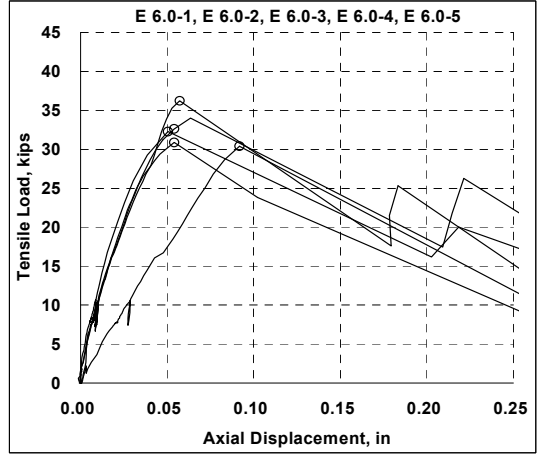

F)

Figure C-2 Graphs of test results of core-drilled anchors installed 6.0 inches away from one edge A) First test in series; B) Second test in series; C) Third test in series; D) Fourth test in series; E) Fifth test in series; F) Comparison of all test in series

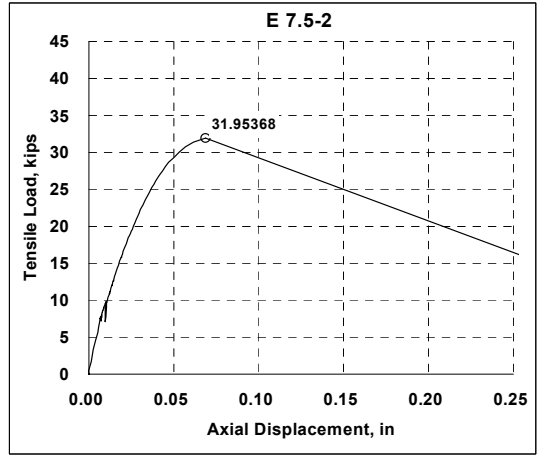
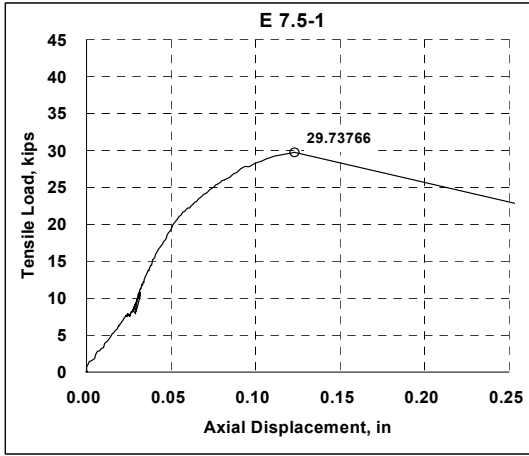

A)

B)

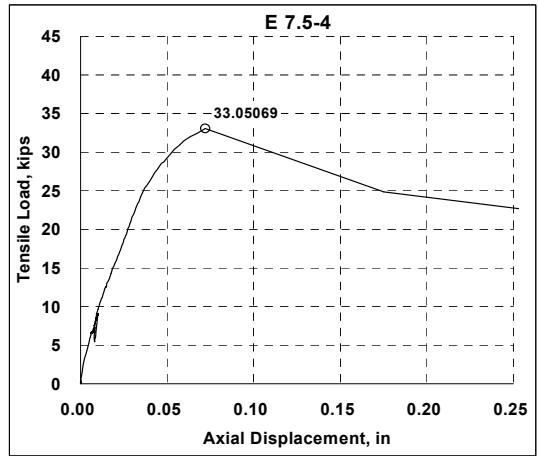
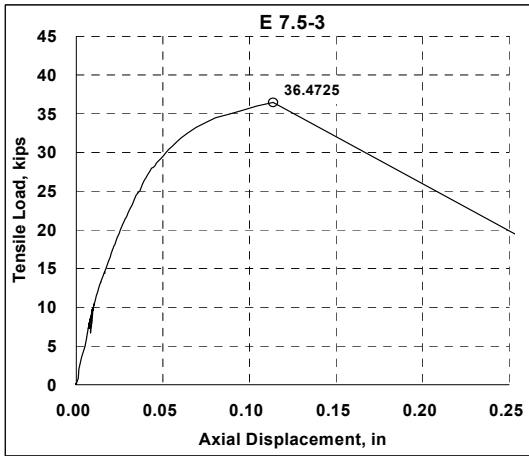

C)

D)

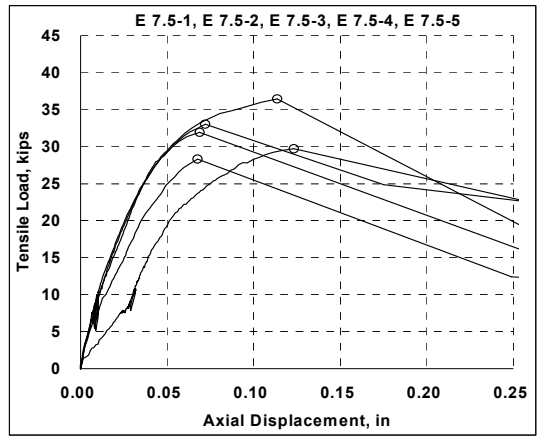
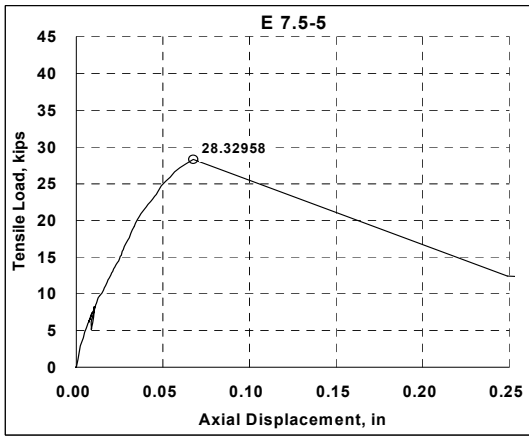

E)

F)

Figure C-3 Graphs of test results of core-drilled anchors installed 7.5 inches away from one edge A) First test in series; B) Second test in series; C) Third test in series; D) Fourth test in series; E) Fifth test in series; F) Comparison of all test in series

APPENDIX D
TENSILE LOAD VS. DISPLACEMENT GRAPHS FOR GROUP TEST SERIES

Anchor group test designation is as follows:

G 5-1 LW 2

Where:

- “G”: First letter specifies the test parameter
G – Multiple anchor (group) test

- “5”: First number identifies the anchor spacing of the test series

- “1”: Second number identifies the group in a series
1 – First group of the series
2 – Second group of the series
3 – Third group of the series

- “LW”: Second and subsequent letters specify the load measuring instrument
LW – Load washer on each individual anchor
OLC – Overall load cell for the whole group

- “2”: Third number identifies the individual anchor on which data is being measured
1 – First anchor of the group
2 – Second anchor of the group
3 – Third anchor of the group
4 – Fourth anchor of the group

Table D-1 Individual group anchor test results

Installation #	Tested Effect	Group in Series	f'_c at test psi (MPa)	Failure Mode	Anchor	N_{test} kips (kN)	$\tau_{0,test}$ psi (MPa)
1	G 5.0	1	7670 (52.9)	cone	1	Error	NA
					2	13.7 (61.1)	NA
					3	15.2 (67.5)	NA
					4	13.2 (58.5)	NA
					All	63.4 (282)	NA
1	G 5.0	2	7670 (52.9)	cone	1	Error	NA
					2	13.8 (61.2)	NA
					3	16.1 (71.8)	NA
					4	16.2 (72.1)	NA
					All	66.9 (298)	NA
1	G 5.0	3	7670 (52.9)	cone	1	Error	NA
					2	16.7 (74.1)	NA
					3	13.67 (60.8)	NA
					4	15.0 (66.6)	NA
					All	62.0 (276)	NA
3	G 9.0	1	7330 (50.5)	g/c	1	Error	Error
					2	27.5 (122)	1170 (8.05)
					3	28.6 (127)	1210 (8.37)
					4	25.3 (112)	1070 (7.39)
					All	105 (465)	1110 (7.65)
3	G 9.0	2	7330 (50.5)	g/c	1	Error	Error
					2	22.2 (98.7)	942 (6.49)
					3	24.3 (108)	1030 (7.10)
					4	32.7 (145)	1390 (9.57)
					All	106 (469)	1120 (7.72)
3	G 9.0	3	7330 (50.5)	g/c	1	Error	Error
					2	21.1 (93.7)	894 (6.16)
					3	23.4 (104)	991 (6.83)
					4	25.5 (114)	1080 (7.47)
					All	100 (446)	1070 (7.34)

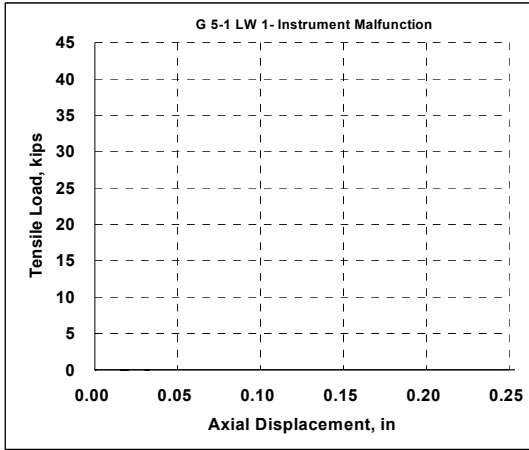

A)

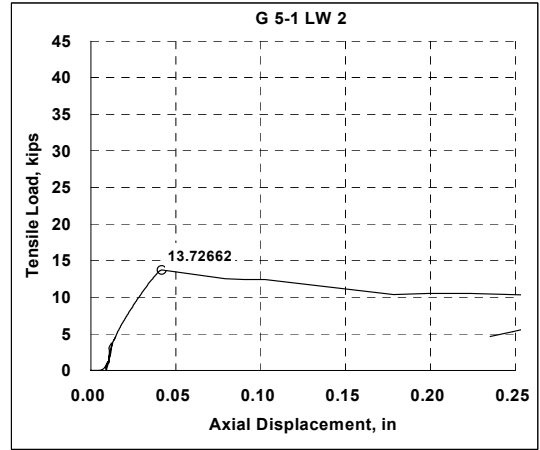

B)

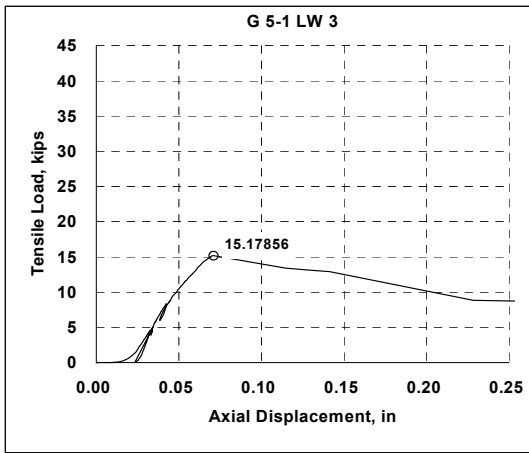

C)

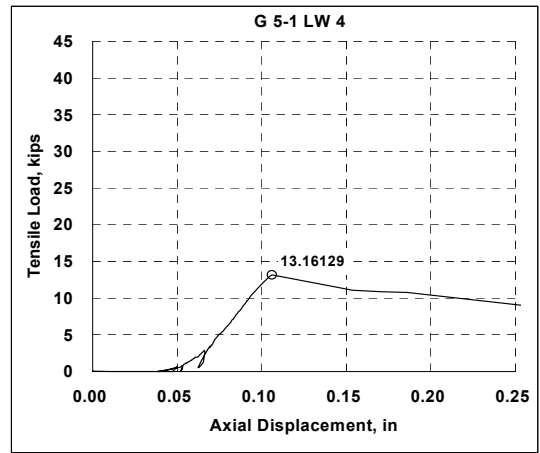

D)

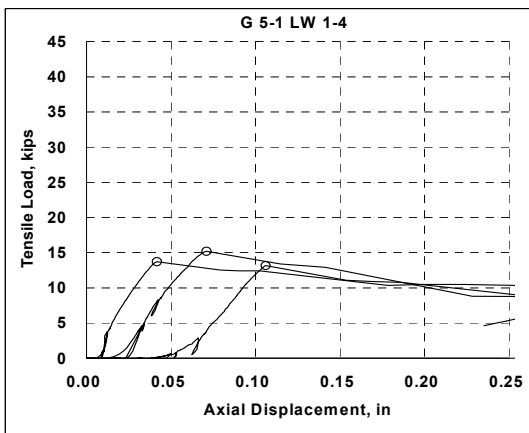

E)

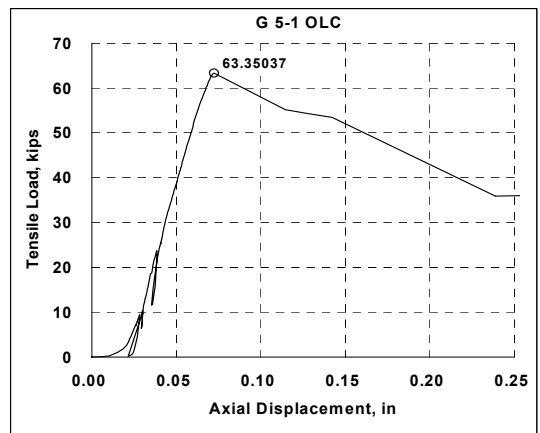

F)

Figure D-1 Graphs of results of first core-drilled anchor group installed with anchor spacing of 5.0 inches A) Load on first anchor; B) Load on second anchor; C) Load on third anchor; D) Load on fourth anchor; E) Comparison of all anchor loads in test; F) Load on entire anchor group

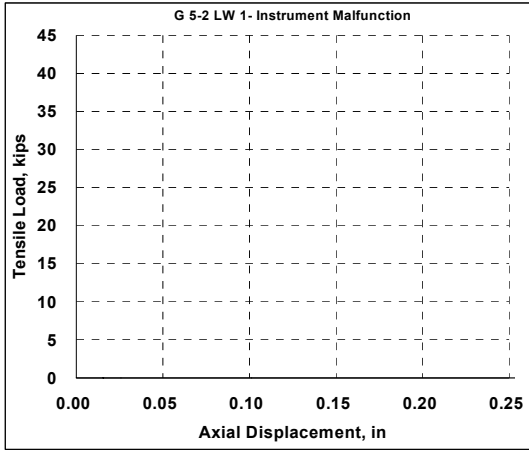

A)

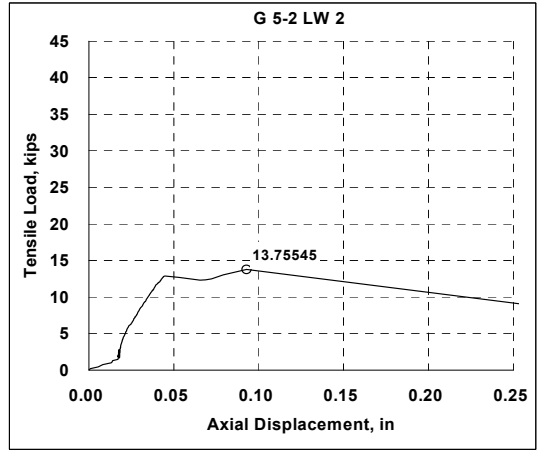

B)

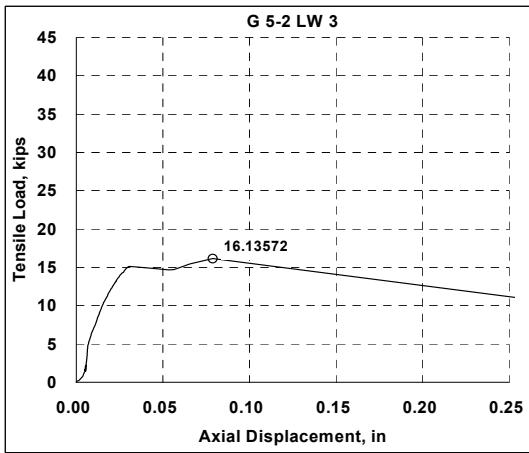

C)

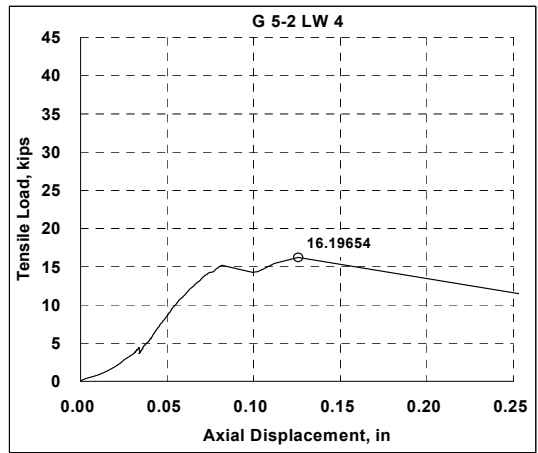

D)

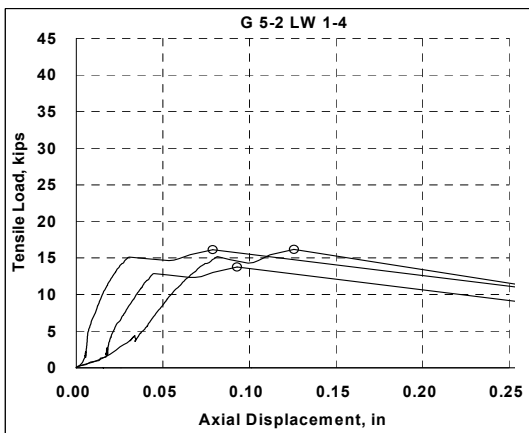

E)

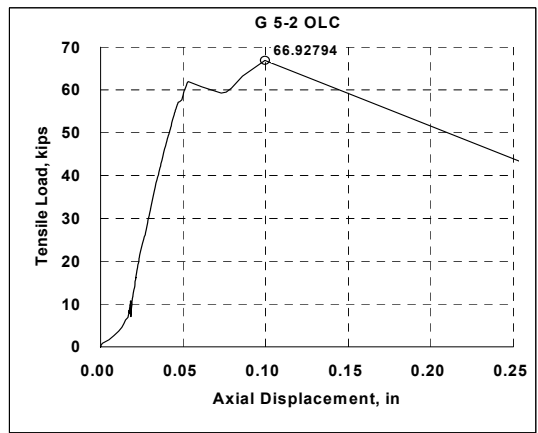

F)

Figure D-2 Graphs of results of second core-drilled anchor group installed with anchor spacing of 5.0 inches A) Load on first anchor; B) Load on second anchor; C) Load on third anchor; D) Load on fourth anchor; E) Comparison of all anchor loads in test; F) Load on entire anchor group

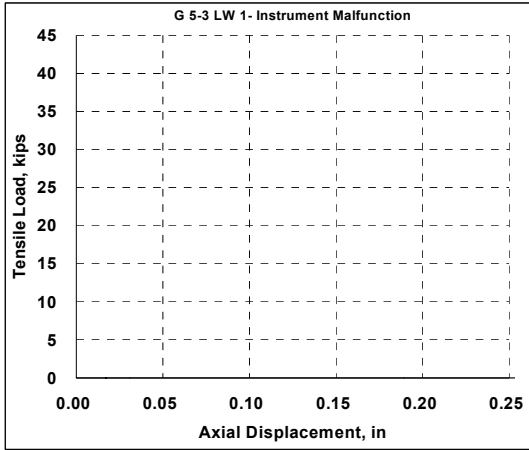

A)

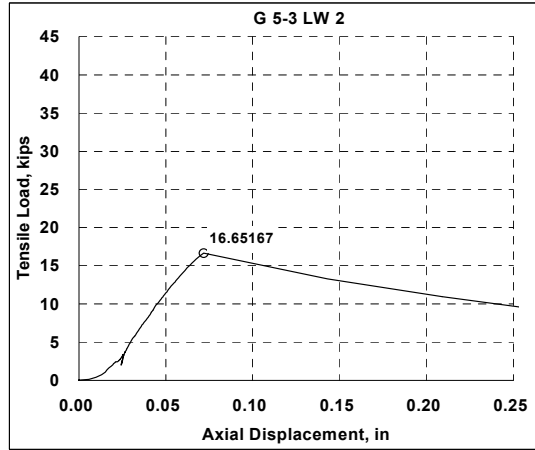

B)

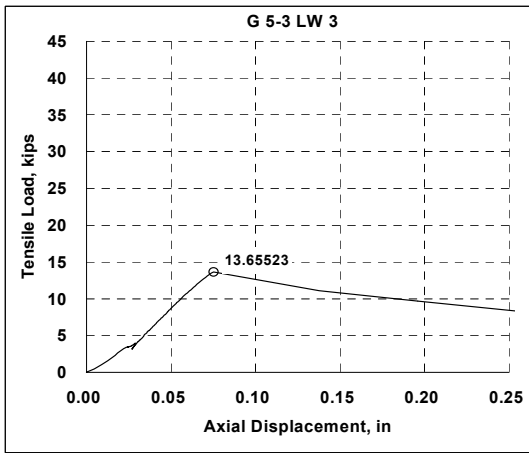

C)

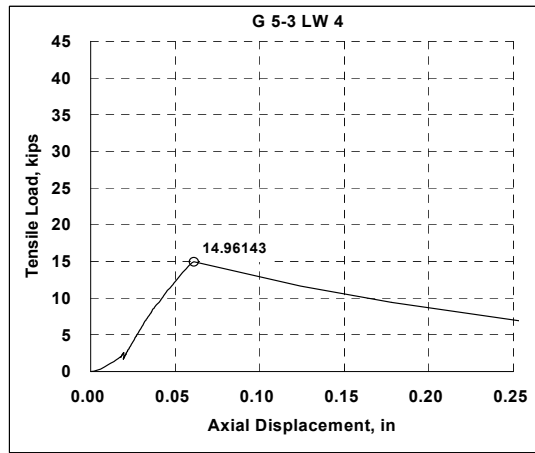

D)

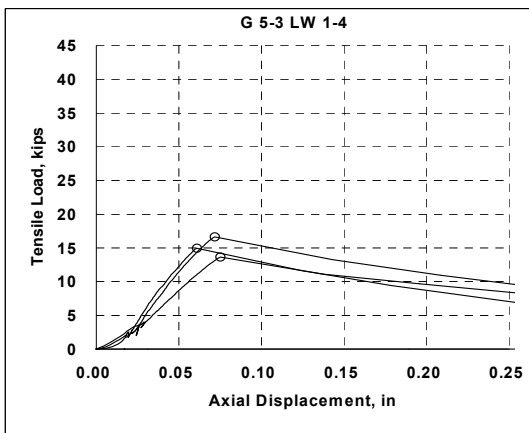

E)

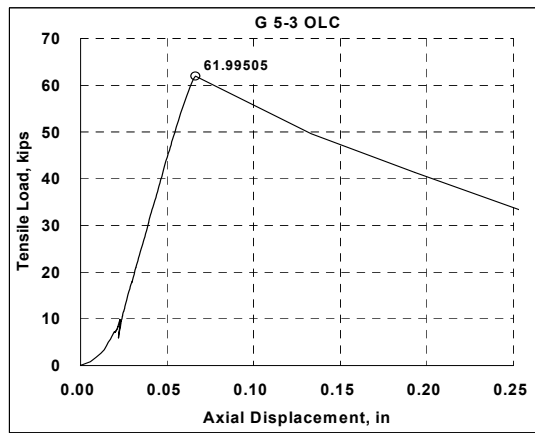

F)

Figure D-3 Graphs of results of third core-drilled anchor group installed with anchor spacing of 5.0 inches A) Load on first anchor; B) Load on second anchor; C) Load on third anchor; D) Load on fourth anchor; E) Comparison of all anchor loads in test; F) Load on entire anchor group

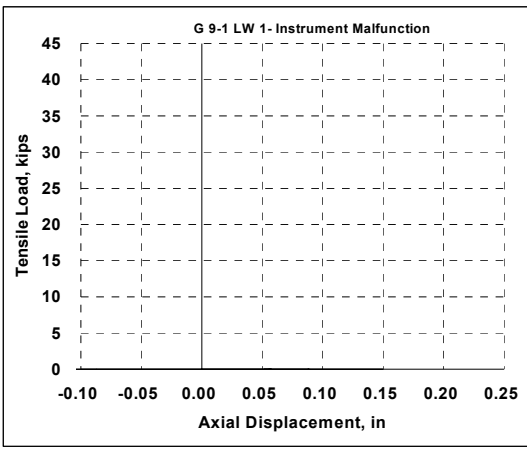

A)

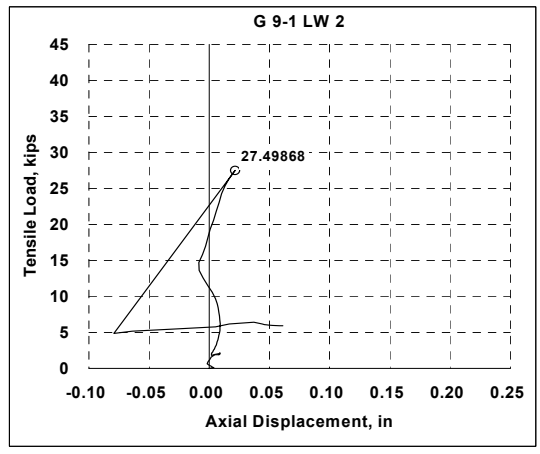

B)

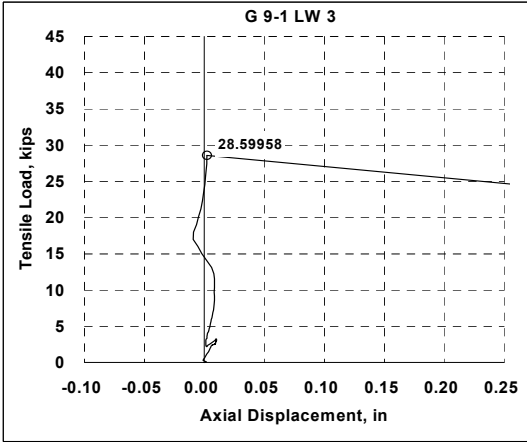

C)

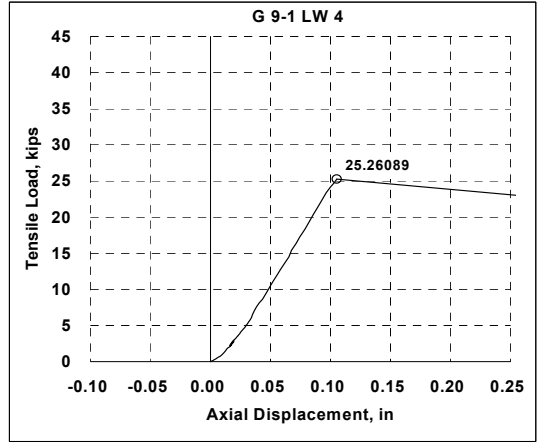

D)

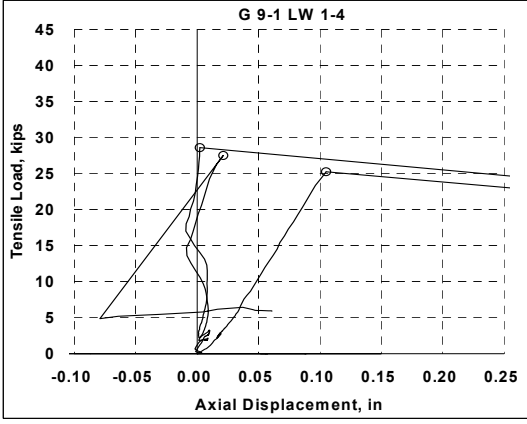

E)

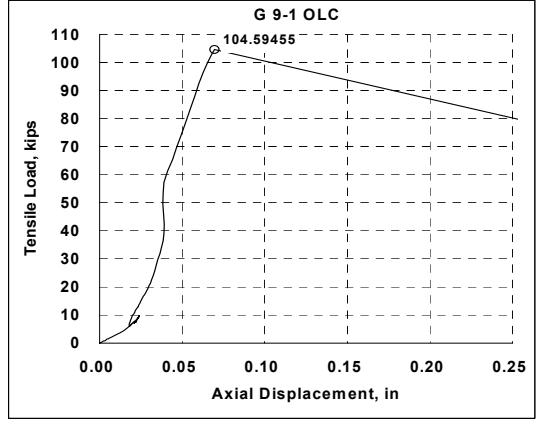

F)

Figure D-4 Graphs of results of first core-drilled anchor group installed with anchor spacing of 9.0 inches A) Load on first anchor; B) Load on second anchor; C) Load on third anchor; D) Load on fourth anchor; E) Comparison of all anchor loads in test; F) Load on entire anchor group

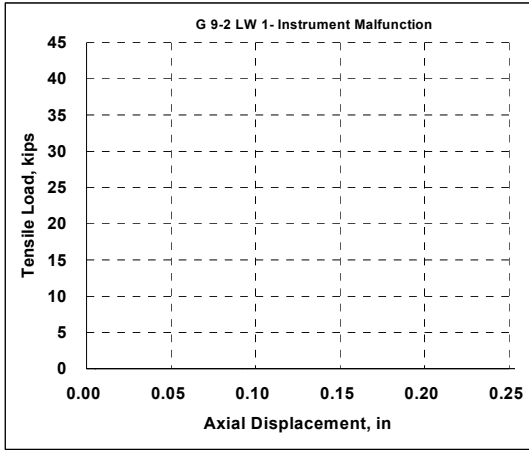

A)

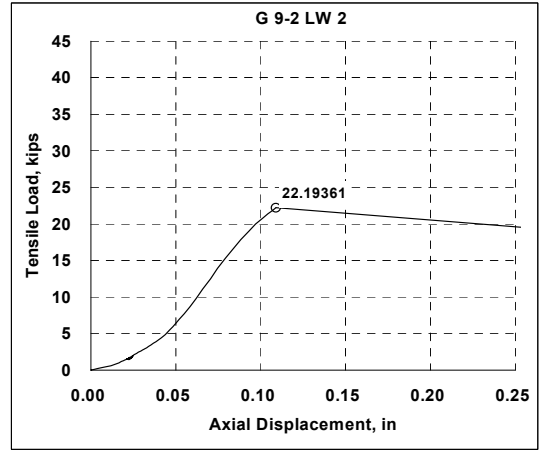

B)

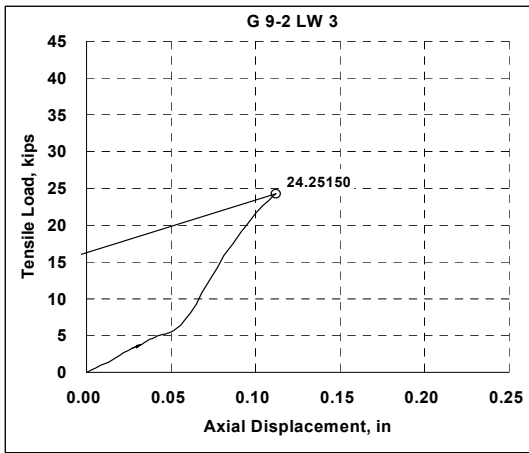

C)

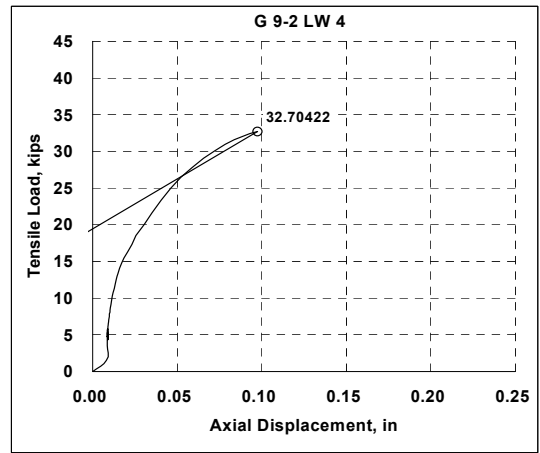

D)

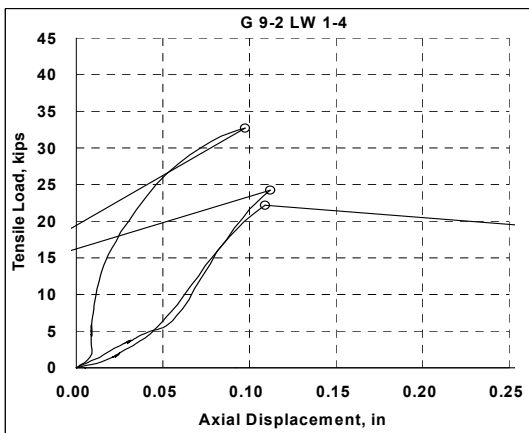

E)

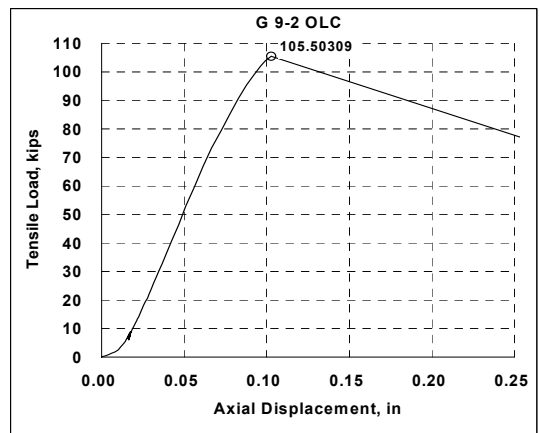

F)

Figure D-5 Graphs of results of second core-drilled anchor group installed with anchor spacing of 9.0 inches A) Load on first anchor; B) Load on second anchor; C) Load on third anchor; D) Load on fourth anchor; E) Comparison of all anchor loads in test; F) Load on entire anchor group

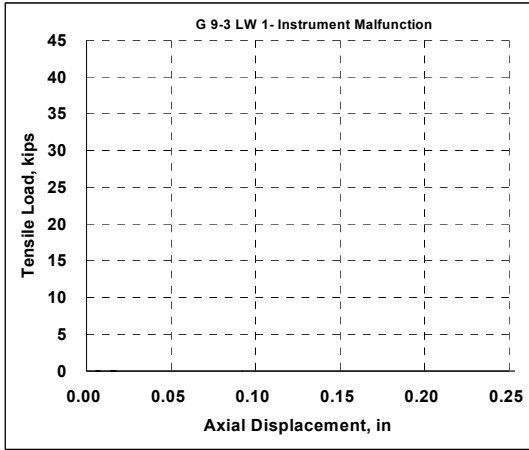

A)

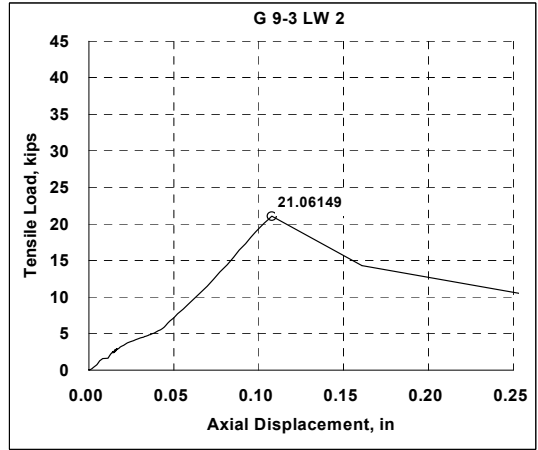

B)

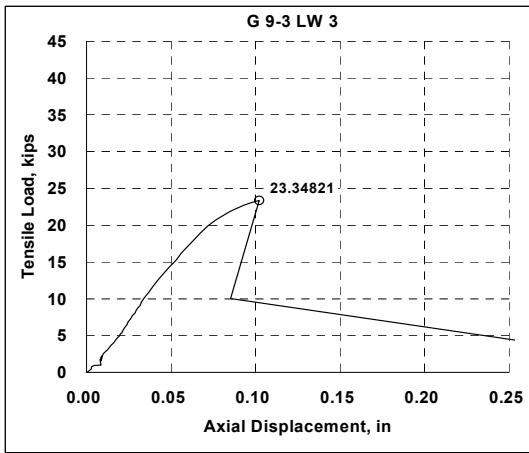

C)

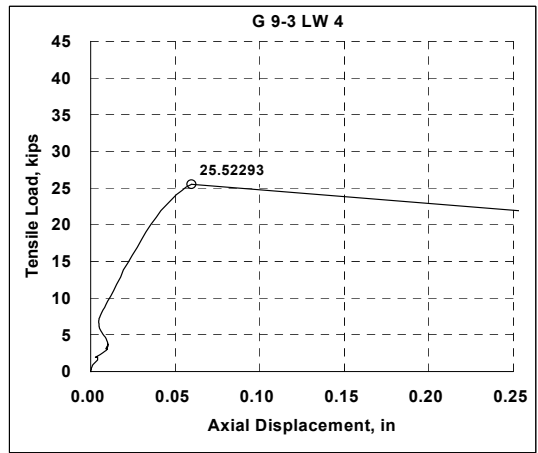

D)

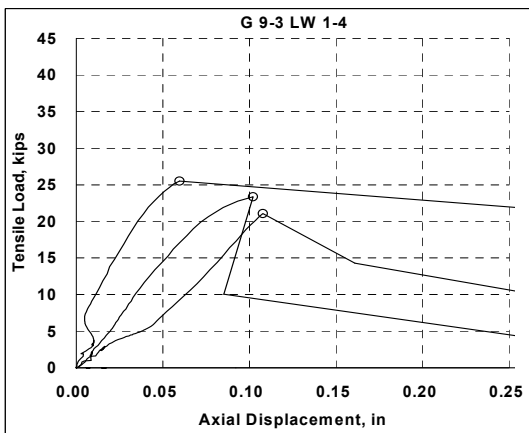

E)

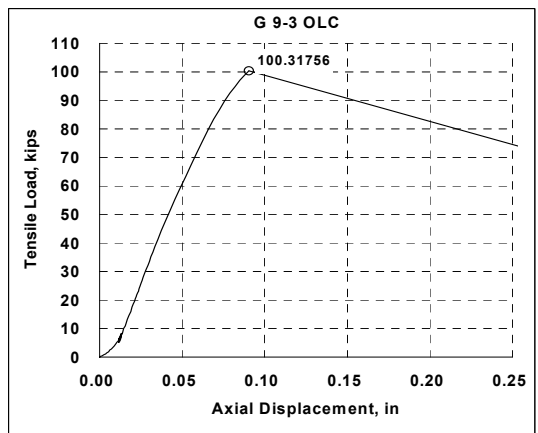

F)

Figure D-6 Graphs of results of third core-drilled anchor group installed with anchor spacing of 9.0 inches A) Load on first anchor; B) Load on second anchor; C) Load on third anchor; D) Load on fourth anchor; E) Comparison of all anchor loads in test; F) Load on entire anchor group

APPENDIX E
REPRESENTATIVE PHOTOGRAPHS OF ANCHOR SPECIMENS FROM TESTING



Figure E-1 Typical grout/concrete bond failure of single core-drilled anchor with grout plug



Figure E-2 Typical grout/concrete bond failure of single anchor with secondary shallow concrete cone



Figure E-3 Grout/concrete bond failure of single core-drilled anchor with secondary shallow cone removed and grout plug exposed



Figure E-4 Typical grout/concrete bond failure of single hammer-drilled anchor with grout plug



Figure E-5 Typical grout/concrete bond failure of single hammer-drilled anchor with secondary shallow concrete cone and grout plug



Figure E-6 Typical grout/concrete bond failure of single core-drilled anchor installed 4.5 inches from one edge with grout plug and diagonal cracking of surrounding concrete



Figure E-7 Typical grout/concrete bond failure of single core-drilled anchor installed 6.0 inches from one edge with grout plug



Figure E-8 Typical grout/concrete bond failure of single core-drilled anchor installed 7.5 inches from one edge with grout plug



Figure E-9 Typical surface view of cone failure of quadruple fastener anchor group with anchor spacing of 5 inches



Figure E-10 Typical dissection view of cone failure of quadruple fastener anchor group with anchor spacing of 5 inches



Figure E-11 Typical grout/concrete failure of quadruple fastener anchor group with anchor spacing of 9 inches

APPENDIX F
 COMPILATION OF PRODUCT APPROVAL TEST RESULTS

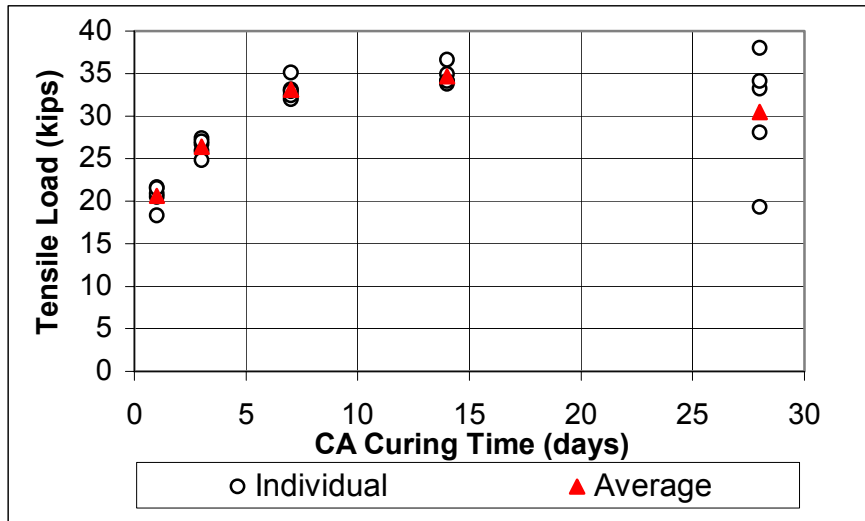

Figure F-1 Strength versus curing time for product CA

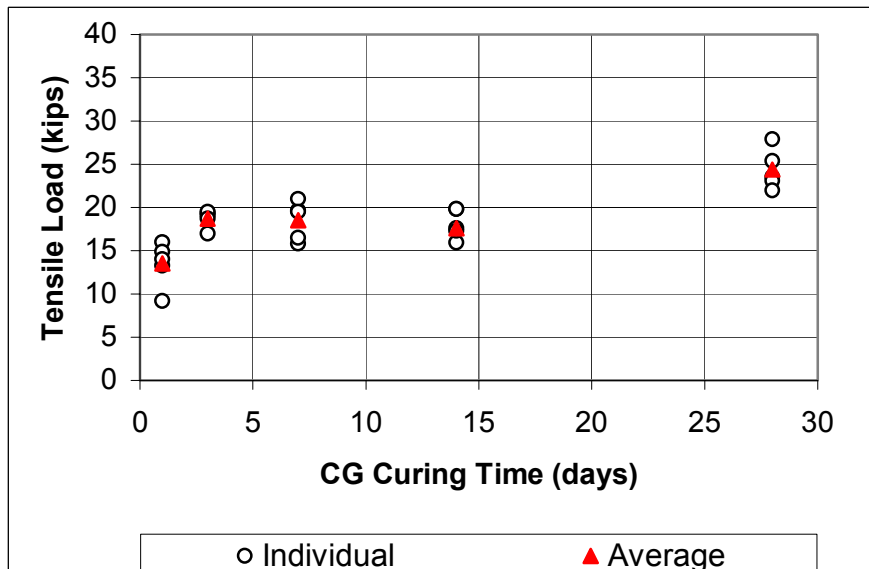

Figure F-2 Strength versus curing time for product CG

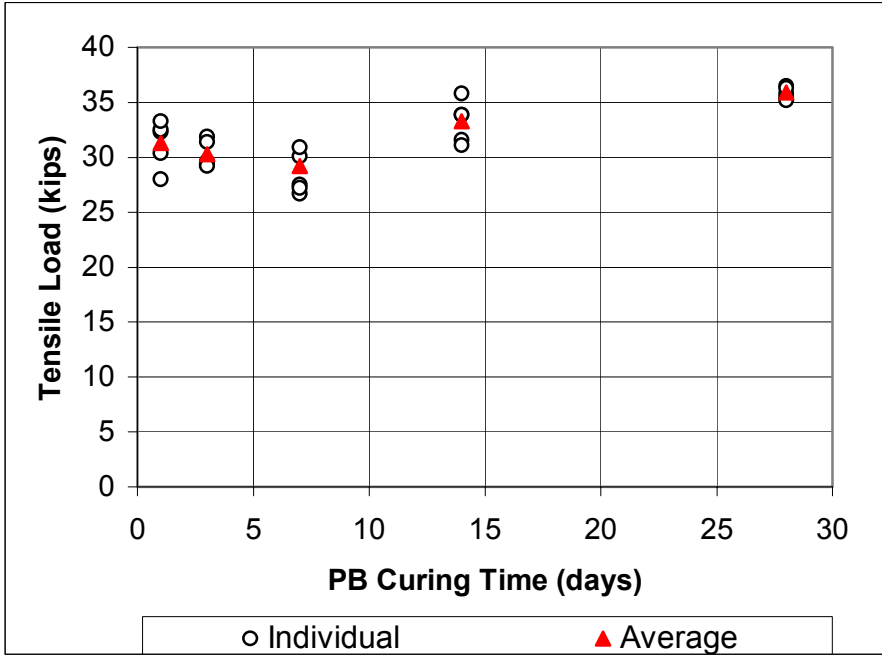

Figure F-3 Strength versus curing time for product PB

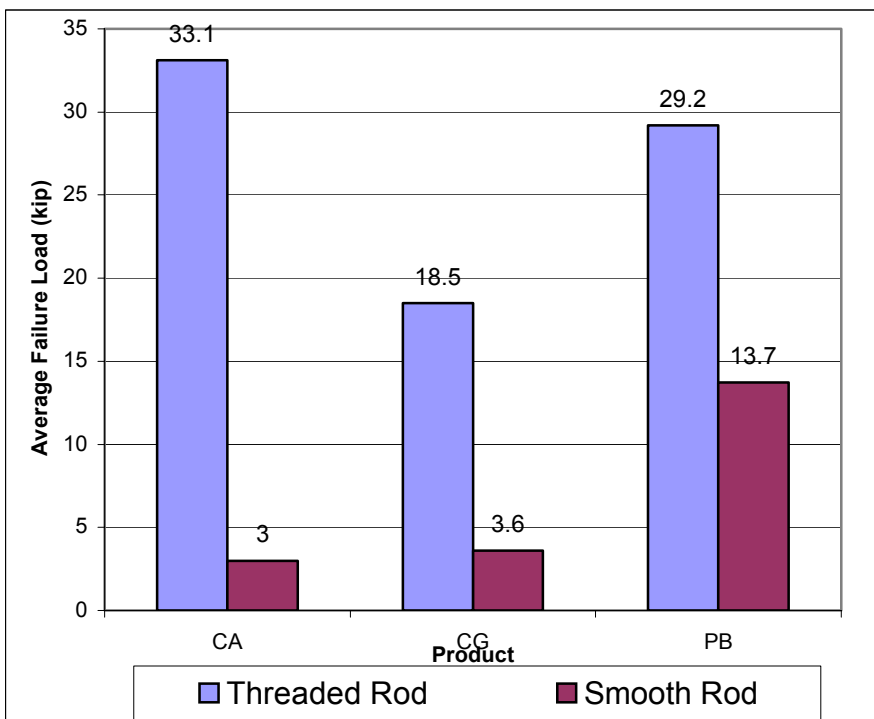

Figure F-4 Comparison of average failure loads for installation with threaded rods and smooth rods

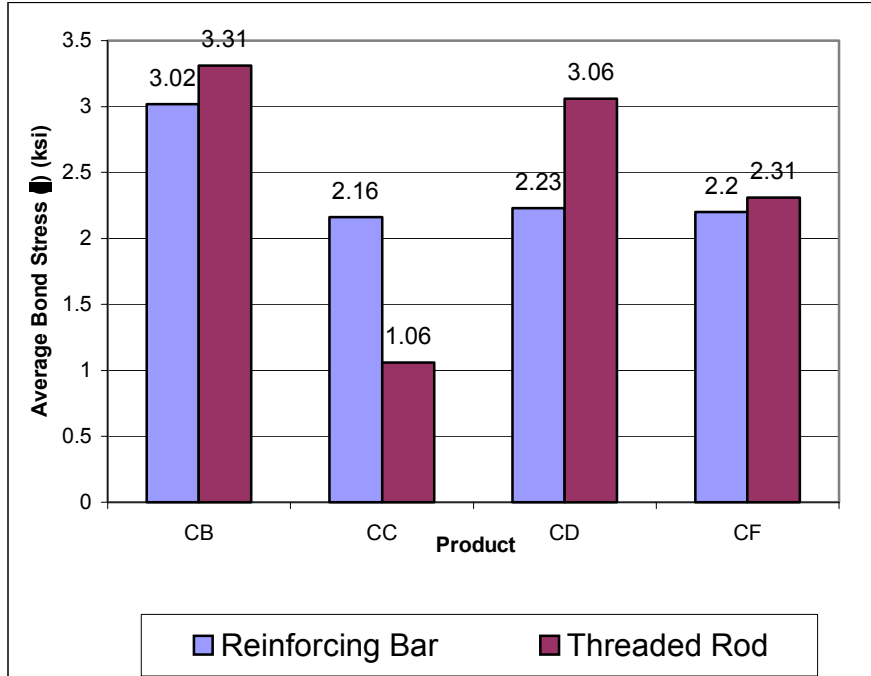

Figure F-5 Comparison of average bond stresses for installation with threaded rods and reinforcing bars

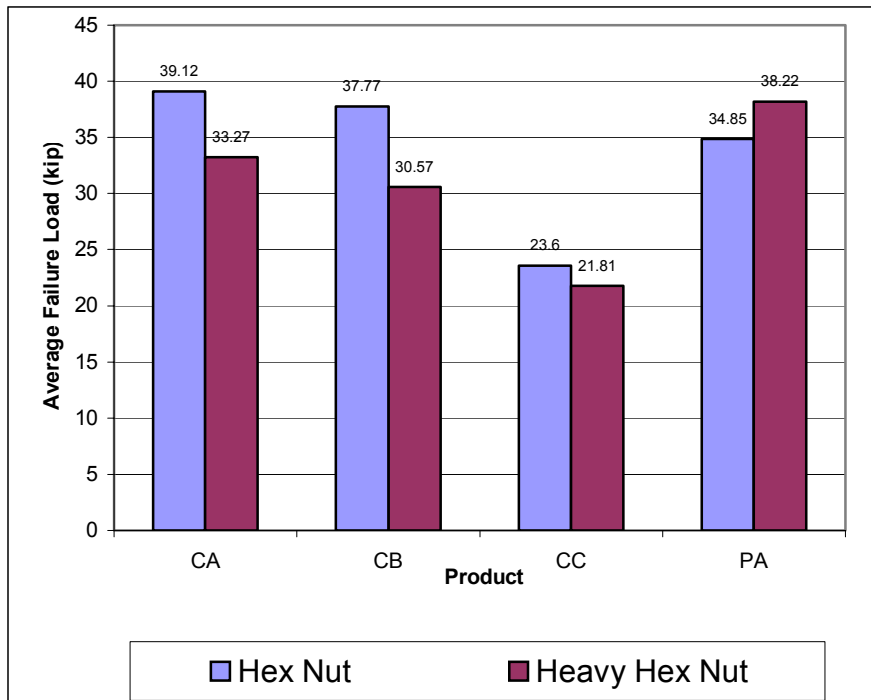

Figure F-6 Comparison of average failure loads for installation of headed anchors with regular hex nuts and heavy hex nuts

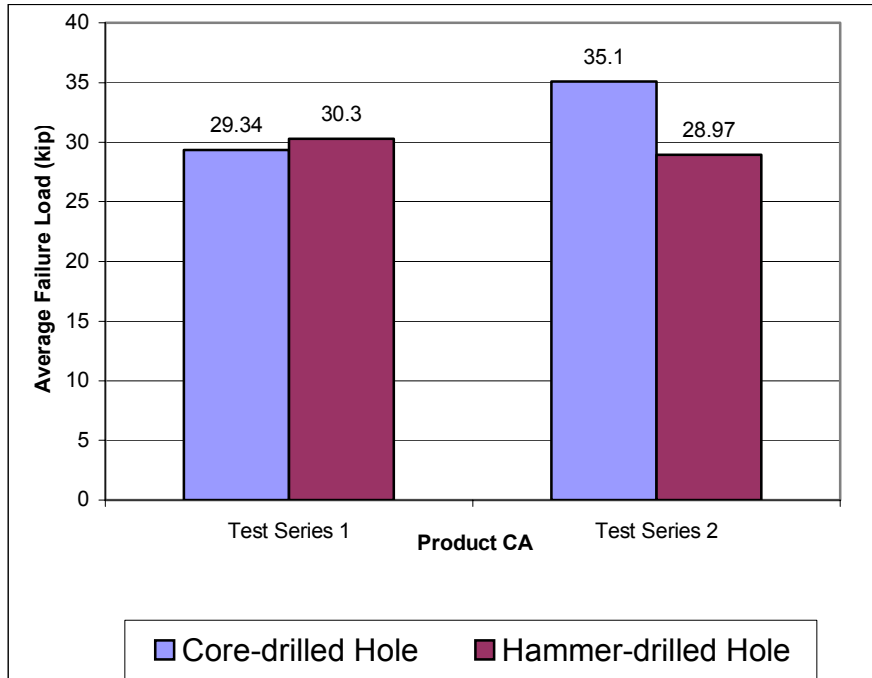

Figure F-7 Comparison of average failure loads for installation in core-drilled and hammer-drilled holes

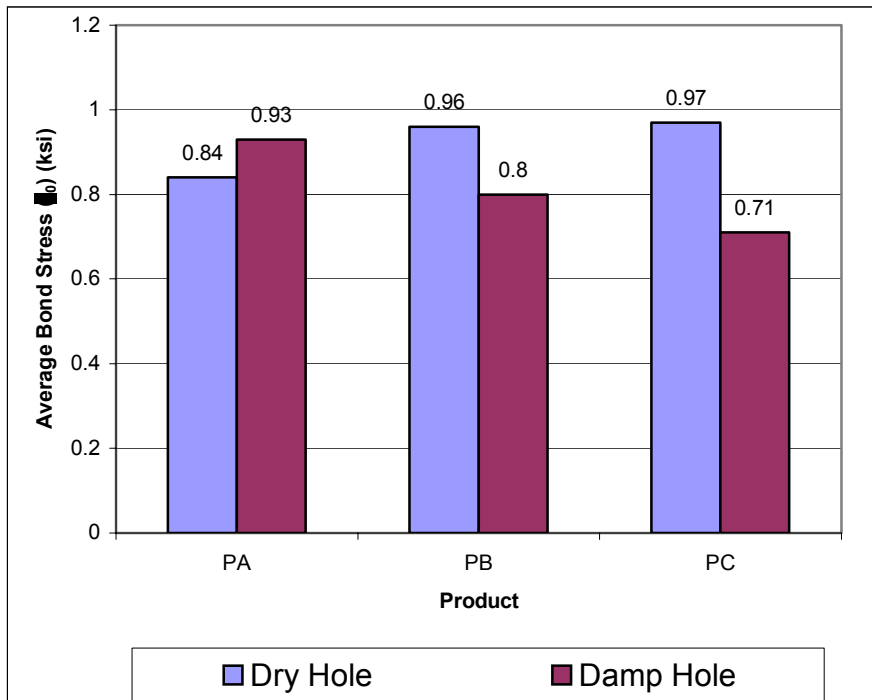

Figure F-8 Comparison of average bond stresses for installation in damp and dry holes

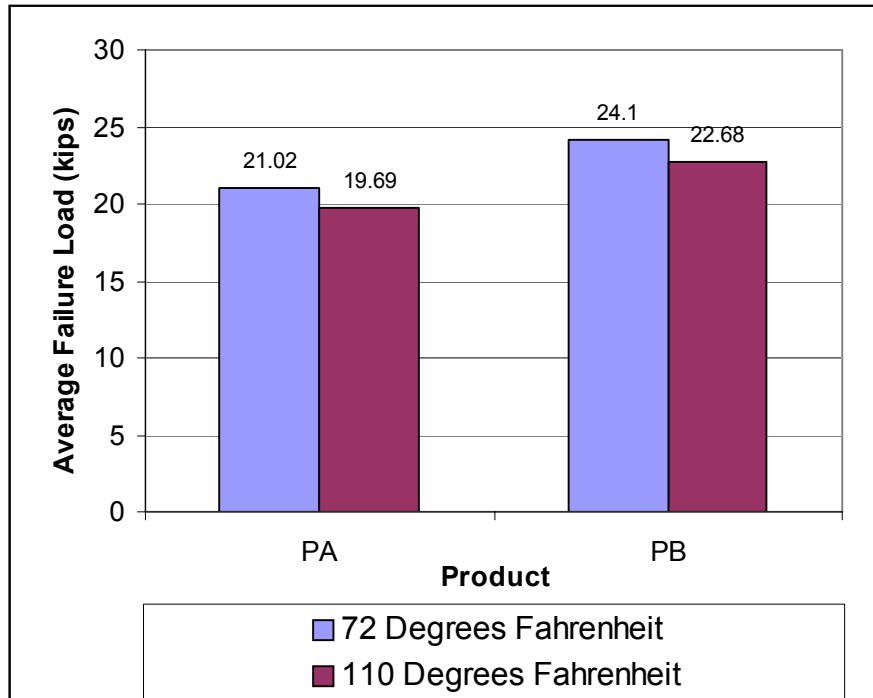

Figure F-9 Comparison of average failure loads for tests performed at ambient and elevated temperatures

APPENDIX G
PROPOSED REVISIONS TO FDOT SECTION 416 TO INCLUDE GROUTED
ANCHORS

PROPOSED REVISED COPY -- NOT FOR DISTRIBUTION OR USE

416 INSTALLING ~~ADHESIVE~~-BONDED ANCHORS AND DOWELS FOR STRUCTURAL APPLICATIONS.

~~(REV 5-1-02) (FA 7-19-02) (1-03)~~ Change dates as appropriate.

SECTION 416 (Pages ~~429~~ and ~~430~~) is deleted and the following substituted:

**SECTION 416
INSTALLING ~~ADHESIVE~~-BONDED ANCHORS AND DOWELS
FOR STRUCTURAL APPLICATIONS**

416-1 Description.

Prepare and install ~~adhesive~~-bonded anchors and dowels in hardened concrete as indicated in the Contract plans, as directed by the Engineer, and in accordance with the manufacturer's instructions and this Section.

Anchors and dowels in this Section are intended for use in structural applications where designated on the Contract plans.

Bonding material systems are defined as either adhesives or grouts. Adhesive bonding material systems for structural applications shall consist of pre-packaged 2-part chemical components. Grouted bonding material systems can be either polymer or cementitious. Polymer grouts are similar to adhesive bonding material systems but contain a filler of fine aggregate as an additional component. Cementitious grouts shall consist of a pre-packaged proportioned amount of cement, fine aggregate, and proprietary additives to which water is added at the time of mixing.

416-2 Materials.

Use ~~adhesive~~-bonding material systems which meet the requirements of Section 937, and are included on the Qualified Products List. For applications involving installation of traffic railing barrier reinforcement and anchor bolts to existing bridge decks and approach slabs, use only Type HSHV adhesives or grouts.

416-2.1 Storage of Materials: Store materials delivered to the job-site in the original unopened containers within an appropriate facility capable of maintaining storage conditions consistent with the manufacturer's recommendations.

416-3 Equipment.

Ensure that the equipment used to install ~~adhesive~~-bonded anchors and dowels is in conformance with the recommendations of the manufacturer.

416-4 Preparing of Concrete Members.

Ensure that concrete members receiving ~~adhesive~~-bonded anchors or dowels are structurally sound and free of cracks in the vicinity of the anchor or dowel to be installed. For adhesive anchors, Uunless other equipment is recommended by the adhesive manufacturer, drill holes to the diameter required by the manufacturer, but as a minimum, not less than 105% of the diameter including deformations, nor more than 150% of the nominal diameter of the steel bar anchor or dowel, using a rotary hammer drill and bit. For grouted anchors, unless other equipment is recommended by the grout manufacturer, drill holes to the diameter required by the manufacturer, but as a minimum, not less than 150% of the diameter including deformations of the steel bar anchor or dowel, using a core drill and bit.

Use a metal detector specifically designed for locating steel in concrete to avoid conflicts with existing steel reinforcement whenever placement tolerances and edge clearances permit. Perform core drilling to clear existing steel reinforcement only when approved by the Engineer. When adhesive or polymer grout products are to be used, Dry the drilled holes completely prior to cleaning and installing the anchors or dowels.

Clean and prepare drilled holes in accordance with the manufacturer's recommendations, but as a minimum for installation with adhesive products or polymer grout products, use oil-free compressed air to remove loose particles from drilling, brush inside surface to free loose particles trapped in pores, then use compressed air again to remove the remaining loose particles. As a minimum for installation with cementitious grouts products, flush the hole with clean water to remove loose particles from drilling, brush inside surface to free loose particles trapped in pores, then flush with clean water again to remove the remaining loose particles. In all holes, Use a non-metallic bristle brush and avoid over-brushing to prevent polishing the inside surface of the drilled hole.

416-5 Installing of Anchors or Dowels.

Remove all debris, oils, and any other deleterious material from the anchors and dowels to avoid contamination of the ~~adhesive~~-bonding material. Install anchors or dowels in accordance with the details shown on the plans and the manufacturer's instructions, with particular attention to requirements and/or limitations due to anchor position, ~~dampness~~moisture condition of the hole, ambient temperature, and curing.

Use adequate quantities of the ~~adhesive~~-bonding material to fill the drilled hole to within 1/4 inch [5 mm] of the concrete surface measured after placement of the steel bar or anchor. For horizontal and inclined installations, provide temporary supports to maintain the anchors or dowels in the center of the drilled holes until the ~~adhesive~~-bonding material has cured.

416-6 Testing of Anchors or Dowels.

Field test installed anchors and dowels for traffic railing barrier applications using Type HSHV adhesives or Type HSHV grouts. The Engineer may also require testing of installed anchors and dowels for other applications. Testing must be conducted by an Independent Testing Agency approved by the Engineer.

416-6.1 Field Testing: Provide a qualified professional Independent Testing Agency to perform field testing of the installed anchors and dowels in accordance with the applicable sections of ASTM E 488 and ASTM E 1512, in the presence of the Engineer. Perform restrained static tension tests to prevent damage, when possible, to the surrounding concrete, except anchors installed as headed should be tested using unconfined static tension tests. Displacement measurement for field testing is not required. Test individual anchors and dowels by proof loading in tension to 85% of the Specified Bond Strength in Section 937, based on the nominal anchor or dowel diameter and embedment depth, but not more than 90% of the yield strength of the anchor or dowel.

Divide the anchors and dowels into LOTs for testing and acceptance. Each LOT must be all headed or all unheaded specimens and contain a maximum of 100 anchors or dowels, of the same diameter, embedment length and ~~Adhesive~~-Bonding Material System. Randomly select 10% of the anchors and dowels in each LOT for testing, with a minimum of five tests per LOT, unless otherwise directed by the Engineer. For every failed field test, perform two additional field tests on adjacent untested anchors or dowels within the LOT. Continue additional field tests until no more test failures occur, or all anchors and dowels within the LOT are tested. Determine failure of the field test in accordance with ASTM E 488. Submit certified test reports from the Independent Testing Agency to the Engineer for each LOT.

416-6.2 Removal & Replacement of Failed Test Specimens: Remove all anchors and dowels that fail the field test, without damage to the surrounding concrete. Redrill holes to

remove adhesive bonding material residue and clean in accordance with 416-4. Reinstall new anchors and dowels in accordance with 416-5. Do not reuse the failed anchors and dowels unless approved by the Engineer. Assign reinstalled anchors into new LOTs only containing [all headed](#) or [all unheaded](#) reinstalled anchors or dowels of the same diameter, embedment length and ~~adhesive~~-bonding material system, and field test in accordance with 416-6.1.

416-7 Acceptance.

The Engineer will base acceptance of ~~adhesive~~-bonded anchors and dowels on determining that the material requirements of Section 937, the installation and testing requirements of this Section, and the placement requirements of the plans have been met.

416-8 Basis of Payment.

The work specified in this Section will not be paid for directly, but will be considered as incidental work.

APPENDIX H
PROPOSED REVISIONS TO FDOT SECTION 937 TO INCLUDE GROUTED
ANCHORS

PROPOSED REVISED COPY -- NOT FOR DISTRIBUTION OR USE

937 ~~ADHESIVE~~ BONDING MATERIAL SYSTEMS FOR STRUCTURAL APPLICATIONS.

~~(REV 4-30-02) (FA 7-25-02) (1-03)~~ Change dates as appropriate.

SECTION 937 (Pages ~~873-875~~) is deleted and the following substituted:

**SECTION 937
~~ADHESIVE~~ BONDING MATERIAL SYSTEMS
FOR STRUCTURAL APPLICATIONS**

937-1 General Requirements.

Bonding material systems are defined as either adhesives or grouts. Adhesive bonding material systems for structural applications shall consist of pre-packaged 2-part chemical components. Grouted bonding material systems can be either polymer or cementitious. Polymer grouts are similar to adhesive bonding material systems but contain a filler of fine aggregate as an additional component. Cementitious grouts shall consist of a pre-packaged proportioned amount of cement, fine aggregate, and proprietary additives to which water is added at the time of mixing. The material systems shall be specifically intended for use in structural applications for bonding anchors and dowels to hardened concrete. Applications are limited to anchors and dowels installed in positions ranging from vertically downward to horizontal.

Adhesive M material systems for Type V materials may be supplied in two pre-proportioned containers with one container sized to allow the contents of the second container to be added and mechanically mixed. The two components shall be distinctly pigmented so that mixing produces a third color similar to the color of concrete. Polymer grout material systems for Type V materials may be supplied in a similar manner to adhesives. The resin and the curing agent (hardener) are combined first. Then the fine aggregate, which functions as a filler, is mixed with the resin mixture. Cementitious grout material systems for Type V materials may be supplied in a pre-packaged bag that contains the proper proportions of cement, fine aggregate, and proprietary additives. This material is mixed with water as recommended by the manufacturer to achieve the proper flow rate for installation. Do not use material from containers which are damaged or have been previously opened. Use only full packages of components. Combining of epoxy bonding components from bulk supplies is not permitted.

Adhesive M material systems for Type HV and HSHV shall be pre-packaged to automatically proportion and mix the materials for use. Manual proportioning of the components will not be permitted.

937-1.1 Type V-Adhesives: Use Type V ~~adhesive~~-bonding materials, except non-quick setting cementitious grouts, for constructing doweled pile splices in concrete piles. Type V ~~adhesives~~ materials may not be substituted for Type HV or HSHV ~~adhesives~~ materials.

937-1.2 Type HV-Adhesives: Use Type HV ~~adhesive~~-bonding materials for all horizontal installations and vertical installations other than constructing doweled pile splices, except when Type HSHV is required. Type HV ~~adhesives~~ materials may not be substituted for Type HSHV ~~adhesives~~ materials.

937-1.3 Type HSHV-Adhesives: Use higher strength Type HSHV ~~adhesive~~-bonding materials for installation of traffic railing barrier reinforcement and anchor bolts into existing concrete bridge decks and approach slabs. Type HSHV ~~adhesives~~ materials may be substituted for Type V or Type HV ~~adhesives~~ materials.

937-2 Qualified Products List.

Manufacturers of ~~adhesive~~ bonding material systems may apply for inclusion of individual products on the Qualified Products List. The application shall be made in accordance with 6-1 and shall include certified test reports from an independent testing laboratory which shows the material system meets all the requirements specified herein.

937-3 Minimum Performance Requirements (FM 5-568).

When tested in accordance with FM 5-568, the ~~adhesive~~ bonding material system, for general use, shall meet the following requirements:

Uniform Bond Stress*			
	Type V (τ , τ_0)	Type HV (τ , τ_0)	Type HSHV (τ , τ_0)
Confined Tension**	2,290 psi [15.8 MPa] 1,530 psi [10.5 MPa]	2,290 psi [15.8 MPa] 1,530 psi [10.5 MPa]	3,060 psi [21.1 MPa] 2,040 psi [14.1 MPa]
Damp-Hole Moisture Condition Installation	1,680 psi [11.6 MPa] 1,120 psi [7.7 MPa]	1,680 psi [11.6 MPa] 1,120 psi [7.7 MPa]	1,830 psi [12.6 MPa] 1,220 psi [8.4 MPa]
Elevated Temperature	2,290 psi [15.8 MPa] 1,530 psi [10.5 MPa]	2,290 psi [15.8 MPa] 1,530 psi [10.5 MPa]	3,060 psi [21.1 MPa] 2,040 psi [14.1 MPa]
Horizontal Orientation	Not Applicable, Not Applicable	2,060 psi [14.2 MPa] 1,370 psi [9.5 MPa]	2,060 psi [14.2 MPa] 1,370 psi [9.5 MPa]
Short-Term Cure***	1,710 psi [11.8 MPa] 1,140 psi [7.9 MPa]	1,710 psi [11.8 MPa] 1,140 psi [7.9 MPa]	1,710 psi [11.8 MPa] 1,140 psi [7.9 MPa]
Specified Bond StrengthStress	1,080 psi [7.5 MPa] 720 psi [5.0 MPa]	1,080 psi [7.5 MPa] 720 psi [5.0 MPa]	1,830 psi [12.6 MPa] 1,220 psi [8.4 MPa]

* If a product is to be installed in a hole type or with an anchor type that is other than that recommended by the bonding product's manufacturer, all the minimum values of this table must be satisfied for approval.

** Confined Tension Tests shall not be performed on headed bonded anchors. Unconfined Tension test shall be performed on headed bonded anchors, but headed bonded anchors shall meet the minimum τ_0 requirements of Confined Tension Tests.

*** Short-Term Cure Tests shall not apply to non-quick setting cementitious grouts.

Maximum Coefficient Of Variation for Uniform Bond Stress 20%

Long Term Load (Creep):

- (1) The rate of displacement shall decrease during the 42 day application of load.
- (2) At 42 days the total displacement due to creep (with load still applied) shall be less than 0.03 inch [0.75 mm] and during the last 14 days of the 42 day load duration, the total displacement due to creep shall be less than 0.003 inch [0.075 mm].
- (3) After removal of the 42 day load, the uniform bond ~~S~~stress from a subsequent ~~€~~Unconfined Tension Test shall not be less than ~~1,826~~1,830 psi [12.6 MPa] for failure at the interface between the anchor and the product or 1,220 psi [8.4 MPa] for failure at the interface between the product and the concrete.

937-4 Product Identification (Fingerprint) Properties (FM 5-569).

References for comparison including Infrared Absorption, Density or Average Weight, Gel Time or Setting Time, and Bond Strength shall be determined in accordance with FM 5-569.

937-5 Packaging and Marking.

The ~~adhesive~~-bonding material system shall be delivered to the project site in original unopened containers with the manufacturer's label identifying the product. Each package shall be clearly marked with the following information:

- Manufacturer's name and address
- Product Name
- Date of Manufacture
- Expiration Date
- LOT Identification Number
- Storage and Handling Requirements

Each package shall include the manufacturer's instructions for anchor and dowel installation. The instructions shall include the following information:

- Diameters of drilled holes for applicable anchor and dowel sizes.
- Cleaning procedure for drilled holes, including a description of permitted and prohibited equipment and techniques.
- Allowable temperature ranges for storage, installation and curing.
- Identification of acceptable mixing/dispensing nozzles [where applicable](#).
- Fabrication requirements for anchors and dowels.
- Description of tools permitted or required for installation.
- Method of identifying properly proportioned and mixed ~~adhesive~~[bonding](#) materials.
- Time and temperature schedule for initial set and full-strength cure.
- Special requirements for special installation conditions such as damp [or dry](#) holes, or horizontal or near horizontal orientation of the anchor or dowel.

APPENDIX I
PROPOSED REVISIONS TO FM 5-568 TO INCLUDE GROUTED ANCHORS

PROPOSED REVISED COPY -- NOT FOR DISTRIBUTION OR USE

Florida Method of Test
for
ANCHOR SYSTEM TESTS FOR ~~ADHESIVE~~-BONDED
ANCHORS AND DOWELS

Designation: FM 5-568

1. SCOPE

1.1 This document describes the test methods for determining the bond strength and performance characteristics of ~~adhesive~~-bonded anchors and dowels in structural applications of connections to uncracked concrete. This method is applicable to products specified under FDOT Standard Specifications Section 937 and installed under Section 416.

2. OUTLINE OF METHOD

2.1 Proposed adhesive or grout products are used to bond threaded steel anchor rods to concrete test members under various installation conditions. Cured specimens are then tested for response to various loading and exposure conditions.

2.2 Referenced Documents

2.2.1 American Society of Testing and Materials, Philadelphia

ASTM E 488 "Standard Test Methods for Strength of Anchors in Concrete and Masonry Elements."

ASTM E 1512 "Standard Test Methods for Testing Bond Performance of Adhesive-Bonded Anchors."

2.2.2 Standard Specifications for Road and Bridge Construction, Florida Department of Transportation.

Section 416 "Installing ~~Adhesive~~-Bonded Anchors and Dowels."

Section 937 "~~Adhesive~~-Bonded Anchors and Dowels"

3. TERMINOLOGY

3.1 Terms used in this document shall have the following meanings:

Adhesive – a two-part structural bonding system consisting of a resin and a curing agent (hardener) which react when mixed to form the chemical bonding agent and that can be divided into epoxies, polyesters, vinylesters, and hybrid systems.

Adhesive Anchor – an unheaded threaded rod, deformed reinforcing bar, or dowel installed in a predrilled hole that is not less than 105% of the diameter including deformations, nor more than 150% of the nominal anchor diameter.

Cementitious Grout – a structural bonding system comprised of cement, fine aggregate, and water, which is added at the time of mixing.

Confined Test Specimen - -a bonded anchor in which the reaction force from a static tension load is sufficiently close to the anchor to preclude concrete failure, but allow bond failure.

Effective Embedment Depth - -the depth through which the anchor transfers force to the surrounding concrete by an ~~n~~-adhesive bond.

Encapsulated System - an adhesive anchor system in which pre-proportioned components are packaged in a capsule. Mixing is accomplished inside the drilled hole as the capsule and its contents are crushed by the anchor rod, which is driven by a rotating drill.

Grouted Anchor – an unheaded threaded rod, deformed reinforcing bar, or dowel, or a headed bolt, rod, or stud installed in a predrilled hole that is not less than 150% of the nominal anchor diameter including deformations.

Injection System - an adhesive anchor system in which pre-proportioned components are contained in separate cartridges. Mixing is automatically accomplished within the cartridge head or by static vanes inside a dispensing nozzle.

Polymer Grout – a three-part structural bonding system consisting of a resin and a curing agent (hardener), similar to adhesive products, but also containing a filler of fine aggregates.

Unconfined Test Specimen - -a bonded anchor in which the reaction force

from a static tension load is a sufficient distance from the anchor to allow concrete failure and/or bond failure.

3.2 Symbols used in this document shall have the following meanings:

d	Nominal diameter of a bonded anchor rod, mm.
d_0	<u>Nominal diameter of a drilled hole, mm.</u>
h_{ef}	Effective embedment depth, mm.
N_0	Tension failure load for a Confined Tension test, kN.
N_d	Tension failure load for a Damp - <u>Moisture Condition of</u> Hole Installation test, kN.
N_h	Tension failure load for a Horizontal Installation test, kN.
N_s	Tension failure load for a Short-Term Cure test, kN.
N_t	Tension failure load for a Elevated Temperature test, kN.
N_u	Tension failure load for a Unconfined Tension test, kN.
$\hat{\tau}_o$	Uniform bond stress for a Confined Tension series <u>at the interface between the anchor and the bonding product</u> , MPa A .
$\hat{\tau}'$	Uniform bond stress <u>strength</u> for an adhesive bonding product <u>at the interface between the anchor and the bonding product</u> , MPa.
$\hat{\tau}_d$	Uniform bond stress for a Damp - <u>Moisture Condition of</u> Hole Installation series <u>at the interface between the anchor and the bonding product</u> , MPa A .
$\hat{\tau}_h$	Uniform bond stress for Horizontal Installation series <u>at the interface between the anchor and the bonding product</u> , MPa A .
$\hat{\tau}_s$	Uniform bond stress for Short-Term Cure series <u>at the interface between the anchor and the bonding product</u> , MPa.
$\hat{\tau}_t$	Uniform bond stress for Elevated Temperature series <u>at the interface between the anchor and the bonding product</u> , MPa A .
$\hat{\tau}_u$	Uniform bond stress for an Unconfined Tension series <u>at the interface between the anchor and the bonding product</u> , MPa A .
$\tau_{0,o}$	<u>Uniform bond stress for a Confined Tension series at the interface between the bonding product and the concrete, MPa.</u>
τ_0'	<u>Uniform bond stress for a bonding product at the interface between the bonding product and the concrete, MPa.</u>
$\tau_{0,d}$	<u>Uniform bond stress for a Moisture Condition of Hole Installation series at the interface between the bonding product and the concrete, MPa.</u>
$\tau_{0,h}$	<u>Uniform bond stress for Horizontal Installation series at the interface between the bonding product and the concrete, MPa.</u>
$\tau_{0,s}$	<u>Uniform bond stress for Short-Term Cure series at the interface between the bonding product and the concrete, MPa.</u>

- $\tau_{0,t}$ Uniform bond stress for Elevated Temperature series at the interface between the bonding product and the concrete, MPa.
- $\tau_{0,u}$ Uniform bond stress for an Unconfined Tension series at the interface between the bonding product and the concrete, MPa.
- v_u Coefficient of variation for an Unconfined Tension series.

4. CALCULATED VALUES

- 4.1 Except as otherwise stated herein, the strength performance of test specimens shall be based on the applied tension load at failure. Failure shall be defined in accordance with ASTM E 488.
- 4.2 An average tension failure load for each test series shall be calculated and reported as the arithmetic mean of the individual failure loads for all specimens in that series.
- 4.3 Coefficients of variation for each applicable test series shall be calculated and reported as the sample standard deviation divided by the mean.
- 4.4 For grouted anchors that experience a bond failure at the anchor/grout interface and for all adhesive anchors, An average uniform bond stress shall be calculated for each test series as:

$$\hat{\tau}_x = \frac{(N_x)_{avg}}{\pi \times d \times h_{ef}} \quad \text{where: } x = o, d, h, s, t, \text{ or } u$$

- 4.5 A specified bond stress strength for the adhesive bonding product shall be calculated as:

$$\hat{\tau}' = \hat{\tau}_u [1 - 2.0 v_u]$$

- 4.6 For grouted anchors that experience a bond failure at the grout/concrete interface, an average uniform bond stress shall be calculated for each test series as:

$$\tau_{0,x} = \frac{(N_x)_{avg}}{\pi \times d_0 \times h_{ef}} \quad \text{where: } x = o, d, h, s, t, \text{ or } u$$

- 4.5 A specified bond stress for the grout product shall be calculated as:

$$\tau_0' = \tau_{0,u}[1-2.0 v_u]$$

5. APPARATUS

- 5.1 The test apparatus shall be as required by the applicable sections of the referenced documents and described herein.
- 5.2 Structural test members shall be constructed using FDOT Class II concrete with limestone aggregate to the minimum dimensions required by ASTM E 488. Members shall be uncracked and unreinforced within the potential failure region of the test specimen. Reinforcement shall only be used to accommodate handling.
- 5.3 Anchor rods with continuous threads shall be fabricated from high-strength steel sufficient to fail the adhesive bond without fracture of the concrete (e.g. ASTM A 193 Grade B7).
- 5.4 An environmental chamber shall be capable of maintaining concrete test members, anchor specimens, and related test apparatus at not less than 43°C for a continuous period of not less than 42 days.

6. SAMPLING

- 6.1 Adhesive and grout products shall be randomly selected by the testing agency from commercial distribution sources.

7. PROCEDURE

- 7.1 Handling, preparation, installation, and curing of proposed adhesive or grout products shall be in accordance with the manufacturer's published instructions. Only tools and dispensing equipment recommended by the manufacturer shall be used. Specimens shall be prepared such that they are representative of field installations of commercially available products.

8. REQUIRED TESTS

- 8.1 Perform each of the following test series in accordance with the applicable sections of ASTM E 488 and ASTM E 1512 except as otherwise stated.
 - 8.1.1 Confined Tension - Perform static tension tests on single anchors except:

-
- a. Anchor diameter shall be 16 mm and embedment shall be 102 mm.
 - b. Test loads shall be applied to confined test specimens.
 - c. Anchors shall be unheaded.

8.1.2 ~~Damp~~ Moisture Condition of Hole Installation - Perform static tension tests on single anchors except:

- a. Anchor diameter shall be 16 mm and embedment shall be 102 mm.
- b. Adhesive and polymer grouted anchors shall be installed in damp holes.
- c. Cementitious grouted anchors shall be installed in dry holes.

8.1.3 Elevated Temperature - Perform static tension tests on single anchors except:

- a. Anchor diameter shall be 16 mm and embedment shall be 102 mm.
- b. Minimum temperature during testing shall be 42°C.
- ~~c. Test loads shall be applied to confined test specimens.~~ Unheaded anchors may be tested as either confined or unconfined specimens.
- d. Headed anchors shall be tested as unconfined specimens.
- e. Cementitious grouts need not be tested for this application.

8.1.4 Horizontal Orientation - Perform static tension tests on single anchors except:

- a. Anchor diameter shall be 16 mm and embedment shall be 102 mm.
- b. The longitudinal axis of the anchor shall be horizontal during installation and curing.
- ~~c. Test loads shall be applied to confined test specimens.~~ Unheaded anchors may be tested as either confined or unconfined specimens.
- d. Headed anchors shall be tested as unconfined specimens.

8.1.5 Short-Term Cure - Perform static tension tests on single anchors except:

- a. Anchor diameter shall be 16 mm and embedment shall be 102 mm.
- b. The longitudinal axis of the anchor shall be horizontal during installation and curing.
- c. Test loads shall be applied no later than 24 hours after installation.
- d. Non-quick setting cementitious grouts should not be used for this application, and therefore short-term cure tests on these products need not be performed.

8.1.6 Long-Term Load (Creep) - Perform static tension tests on single anchors except:

- a. The distance between the reaction force and anchor location of the testing assembly shall be in accordance with the requirements of Table 2 of ASTM E 488.
- b. The minimum long-term test load shall be 40 percent of the average tension failure load established by an Unconfined Tension test series using the same anchor diameter and embedment depth.
- c. The minimum temperature of the concrete test members and anchor specimens during application of the long-term test load shall be 43°C.
- d. The duration of applied load shall be a minimum of 42 days.
- e. After the 42 day loading period, the temperature of the concrete members and anchor specimens shall be permitted to cool to 21°C ± 3°C after which an Unconfined Tension test shall be performed on all anchor specimens.

8.1.7 Unconfined Tension - Perform static tension tests on single anchors except:

- a. A separate test series shall be performed for each of three aspect ratios of h_{ef} and d as follows:
 - 1. An anchor diameter of 16 mm and embedment of 102 mm, and
 - 2. An anchor diameter of 16 mm and embedment of 152 mm, and

3. An anchor diameter of 19 mm and embedment of 152 mm.

9. REPORT

9.1 All installed anchor specimens shall be reported. Any deviations from the requirements of this document shall be identified and described. Any installed specimens not tested shall also be reported with a description of why testing was not performed. A complete and separate report shall be prepared for each proposed adhesive [or grout](#) product, and shall include, as a minimum:

9.1.1 All applicable information required in Section 13 of ASTM E 488, Section 8 of ASTM 1512, and this document.

9.1.2 Manufacturer's published product information including, as a minimum:

a. Complete and detailed instructions for proper installation and curing.

b. Complete and detailed descriptions of any related accessories permitted or required for field installation including mixing nozzles and installation tools.

9.1.3 A statement certifying that all tests were performed in accordance with the requirements of this document with any deviations or untested specimens described within, and are accurately represented by the report result. This statement shall bear the seal of a professional engineer licensed to practice in the State of Florida who is independent of the manufacturer.

APPENDIX J
RECEIPTS FROM CONCRETE POURS

ISSUED: C. ROBERTS
 REVIEWED: F. NIEMCZENIA
 DATE: 10/16/01
 MIX NO.: 02-M0938

A2-0938

CONCRETE MIX DESIGN

CONCRETE SUPPLIER: FLORIDA ROCK INDUSTRIES
 ADDRESS: 1518 N.E. SANTA FE BLVD. HIGH SPRINGS, FLORIDA 32655
 PLANT LOCATION: HIGH SPRINGS TELEPHONE NO: 352/454-1360
 FDOT ASSIGNED PLANT NO.: 26-315 PROJECT NO: 21293415201
 DATE: 10/01/01

w/c = .47

CLASS CONCRETE: II (23 MPA)
 3400

SOURCE OF MATERIALS

COARSE AGGREGATE:	FLORIDA ROCK	GRADE:	57	S.G. (SSD):	2.460
FINE AGGREGATE :	FLORIDA ROCK	F.M.:	2.36	S.G. (SSD):	2.630
PIT NO. (COARSE) :	08-004	TYPE:	CRUSHED LIMESTONE		
PIT NO. (FINE) :	76-349	TYPE:	SILICA SAND		
CEMENT :	FLORIDA ROCK	SPEC:	AASHTO M-85 TYPE II		
AIR ENTR. ADMIX :	MBAE 90	MASTER BUILDERS	SPEC: AASHTO M-154		
1ST ADMIX :	POZZ 80	MASTER BUILDERS	SPEC: AASHTO M-194 TYPE D		
2ND ADMIX :	----		SPEC: ----		
3RD ADMIX :	----		SPEC: ----		
FLY ASH :	S SUPERCEM		SPEC: ASTM C-989		

\$ BLAST FURNACE SLAG AGGREGATE CORRECTION FACTOR = 0.7
 HOT WEATHER METRIC DESIGN MIX

CEMENT	kg:	169.00	285	SLUMP RANGE	:	35.00 TO 115.00	mm
COARSE AGG	kg:	1020.00	1720	AIR CONTENT	:	1.00 TO 6.00	%
FINE AGG	kg:	731.00	1232	UNIT WEIGHT (WET)	:	2249.00	kg/m3
AIR ENT ADMX	mL:	147.00	10	W/C RATIO (PLANT)	:	0.47	kg/kg
1ST ADMIXTURE	mL:	2321.00	60	W/C RATIO (FIELD)	:	0.47	kg/kg
2ND ADMIX	mL:	0.00		THEO YIELD	:	1.00	m3
3RD ADMIX	mL:	0.00					
WATER	L:	160.00					
WATER	kg:	160.00	270				
FLY ASH	kg:	169.00	S				

PRODUCER TEST DATA

CHLORIDE CONT :	0.14	kg/m3
SLUMP :	70.00	mm
AIR CONTENT :	4.90	%
TEMPERATURE :	37.00	DEG C
COMPRESSIVE STRENGTH MPA		
26 -DAY-	42.90	-DAY-
-DAY-		-DAY-

CC:
 D.M.E. 2
 TEST FILE

285
 32.9 g/m³



FLORIDA ROCK INDUSTRIES, INC.

CONTROL NUMBER
93895

UNLOADING

CAUTION
may cause eye or skin injury. Contains Portland cement. Freshly mixed cement, mortar, concrete, or grout may cause skin injury.

- TAKE THESE PRECAUTIONS:**
1. Avoid all contact with eyes.
 2. Wear rubber boots and gloves, and avoid prolonged contact directly with skin or through porous materials.
 3. In case of contact with skin or eyes, FLUSH THOROUGHLY WITH WATER.
 4. If irritation persists, get medical attention promptly.
 5. Keep children away.

Drivers are prohibited from delivering concrete except under the brand own power, and where site conditions permit the safe and proper operation of his equipment. Drivers are not permitted to add water to the mix to exceed the maximum slump or to go beyond the curb line, except upon the authorization of the customer and his acceptance of risk for any loss or damage.

WATER ADDED BY RECEIVER OF CONCRETE _____ GAL
MAX 30 REVS JOBSITE WATER ADDED.

[Signature]
CUSTOMER SIGNATURE

CUSTOMER ID. 93895		P.O. NUMBER 471778		JOB NUMBER 003		DATE 22Feb02		TIME OUT 10:47AM	TIME ON JOB 11:00
SOLD TO University of Florida, Leachville, Fl. 32201				DELIVER TO Civil Eng.		START POUR 11:05		TIME OFF JOB	TIME IN
QUANTITY THIS LOAD	QUANTITY ORDERED	QUANTITY DELIVERED	PRODUCT CODE	PRODUCT DESCRIPTION		UNIT	UNIT PRICE	EXTENDED PRICE	
5.50 4.50 1.00	6.50	6.50	20938	Class 2) 3400 PSI Environmental Surcharge Fuel Surcharge Per Load		yd3			
TRUCK 9905	DRIVER Tommy 23	SLUMP 4"	BATCHED BY JW	USE OF EQUIPMENT 30		EXTRA CHARGES			
DOT MIX ID.	DOT PLANT ID.	ORDERED BY Ron Cook	PLAN 3401	3401 Gainesville RM		SUB TOTAL			
INSTRUCTIONS 352-392-1036						TAX			
						TOTAL			
						GRAND TOTAL			

Material	Target	Actual	Moist	
CEMENT	1852 Lb	1930		FLA ROCK
OSLAG	1852 Lb	1898		LAFARGE
ROCKSTONE SAND	11301 Lb	11300	1.8%	Pit #08-004
	8400 Lb	8360	4.9%	PIT #76-349
Water	51	114 Gal	114 +10	124
Pressure	7	0z	7	Master Builders
Wind	300	0z	300	Master Builders

Water allowed at jobsite: 15 Gal

W/(C+P) Ratio: 0.40

CONTROL NUMBER
93895

Timed 11:10
4" Slump (Free)
370 Aie
75 CT
65 OST

CERTIFICATION: ISSUANCE OF THIS TICKET CONSTITUTES CERTIFICATION TO THE ACCURACY OF THE ABOVE RECORDED INFORMATION AND COMPLIANCE TO THE APPROVED P.C.D. TESTS.

SIGNED BY COMPANY REPRESENTATIVE: *[Signature]*

FORM # 1440 (Rev. 04/01)

OFFICE COPY



FLORIDA ROCK INDUSTRIES, INC.

CONTROL NUMBER

UNLOADING 239679

CAUTION

cause eye or skin injury. Contains Portland cement. Freshly mixed cement, mortar, concrete, or grout may cause skin injury.

TAKE THESE PRECAUTIONS:

1. Avoid all contact with eyes.
2. Wear rubber boots and gloves, and avoid prolonged contact directly with skin or through porous materials.
3. In case of contact with skin or eyes, FLUSH THOROUGHLY WITH WATER.
4. If irritation persists, get medical attention promptly.
5. Keep children away.

Drivers are prohibited from delivering concrete except under the truck's own power, and where site conditions permit the safe and proper operation of his equipment. Drivers are not permitted to add water to the mix to exceed the maximum slump nor to go beyond the curb line, except upon the authorization of the customer and his acceptance of risk for any loss or damage.

WATER ADDED BY RECEIVER OF CONCRETE 7 1/2 GAL
MIX 30 REVS IF JOBSITE WATER ADDED.

Jennifer Bush
CUSTOMER SIGNATURE

CUSTOMER ID. 24361		P.O. NUMBER 471778		JOB NUMBER 023		DATE 18 July 08		TIME OUT 10:58 AM	TIME ON JOB
SOLD TO University of Florida Jacksonville, Fl. 32201				DELIVER TO U/F CIVIL ENG. BLD.		START POUR	END POUR	TIME OFF JOB	TIME IN
QUANTITY THIS LOAD	QUANTITY ORDERED	QUANTITY DELIVERED	PRODUCT CODE	PRODUCT DESCRIPTION		UNIT	UNIT PRICE	EXTENDED PRICE	
7.00	7.00	7.00	20938	Class 2) 3400 PSI		yd3			
1.00			FUELS	Fuel Surcharge Per/Load					
7.00			EF	Environmental Surcharge					
TRUCK 5117	DRIVER RL	SLUMP 4	BATCHED BY ///	USE OF CONCRETE		EXTRA CHARGES			
DOT MIX ID.	DOT PLANT ID.	ORDERED BY JENIFER	PLANT LOCATION 3401 Gainesville RM		SUB TOTAL				
INSTRUCTIONS						TAX			
						TOTAL			
						GRAND TOTAL			

REFERENCE LIST

- ACI Committee 318 (2002), Building Code Requirements for Structural Concrete (ACI 318-02) and Commentary (318R-02), American Concrete Institute, Farmington Hills, Michigan.
- American Society for Testing and Materials (ASTM) (2001a), Standard Test Method for Compressive Strength of Cylindrical Concrete Specimens, *Annual Book of ASTM Standards*, C 39-01. West Conshohocken, Pennsylvania, pp. 18-22.
- American Society for Testing and Materials (ASTM) (2001b), Standard Test Method for Compressive Strength of Hydraulic Cement Mortars (Using 2-in. or [50-mm] Cube Specimens), *Annual Book of ASTM Standards*, C 109-99. West Conshohocken, Pennsylvania, pp. 83-88.
- American Society for Testing and Materials (ASTM) (2001c), Standard Test Method for Flow of Grout for Preplaced-Aggregate Concrete (Flow Cone Method), *Annual Book of ASTM Standards*, C 939-97. West Conshohocken, Pennsylvania, pp. 494-496.
- American Society for Testing and Materials (ASTM) (2001d), Standard Test Method for Strength of Anchors in Concrete & Masonry Elements, *Annual Book of ASTM Standards*, E 488-96. West Conshohocken, Pennsylvania, pp. 66-73.
- American Society for Testing and Materials (ASTM) (2001e), Standard Test Method for Testing Bond Performance of Bonded Anchors, *Annual Book of ASTM Standards*, E 1512-01. West Conshohocken, Pennsylvania, pp. 660-664.
- Cook, R. A., and Konz, R. C. (2001), Factors Influencing Bond Strength of Adhesive Anchors, *ACI Structural Journal*, Vol. 98, No. 1, pp. 76-86.
- Cook, R. A., Kunz, J., Fuchs, W., and Konz, R. C. (1998), Behavior and Design of Single Adhesive Anchors under Tensile Load in Uncracked Concrete, *ACI Structural Journal*, Vol. 95, No. 1, pp. 9-26.
- Florida Department of Transportation (FDOT) (2000), Florida Method of Test for Anchor System Tests for Adhesive-Bonded Anchors and Dowels, Florida Department of Transportation, FM 5-568. Tallahassee, Florida.
- Florida Department of Transportation (FDOT) (2002a), Adhesive Bonding Material Systems for Structural Applications, Florida Department of Transportation, Section 937. Tallahassee, Florida.

- Florida Department of Transportation (FDOT) (2002b), Structures Design Guidelines for Load and Resistance Factor Design, Florida Department of Transportation, Tallahassee, Florida.
- Fuchs, W., Eligehausen, R., and Breen, J. E. (1995), Concrete Capacity Design (CCD) Approach for Fastening to Concrete, *ACI Structural Journal*, Vol. 92, No. 1, pp. 73-94.
- International Congress of Building Officials Evaluation Services (ICBO ES) (2001), Acceptance Criteria for Adhesive Anchors in Concrete and Masonry Elements, International Congress of Building Officials Evaluation Services, AC58. Whittier, California, pp. 1-14.
- James, R. W., De la Guardia, C., and McCreary, Jr., C. R. (1987), Strength of Epoxy-Grouted Anchor Bolts in Concrete, *Journal of Structural Engineering*, American Society of Civil Engineers, Vol. 113, No. 12, pp. 2365-2381.
- Kornreich, B. (2001), Grouted and Adhesive Anchor Tests: Chemrex Products 1090, Thoroc 10-60, 648 CP+, 928, Masters Report, University of Florida, Gainesville, Florida.
- Lehr, B., and Eligehausen, R. (2001), Design of Anchorages with Bonded Anchors under Tension Load, *Connections between Steel and Concrete*, Vol. 1, University of Stuttgart, Germany, pp. 411-421.
- McVay, M., Cook, R. A., and Krishnamurthy, K. (1996), Pullout Simulation of Postinstalled Chemically Bonded Anchors, *Journal of Structural Engineering*, American Society of Civil Engineers, Vol. 122, No. 9, pp. 1016-1024.
- National Instruments Corporation (NI) (1999), LabVIEW Development System (Version 5.1), [Computer program]. Available from National Instruments Corporation, 11500 North Mopac Expressway, Austin Texas 78759-3504.
- Zamora, N. A. (1998), Behavior and Design of Headed and Unheaded Grouted Anchors Loaded in Tension, Masters Report, University of Florida, Gainesville, Florida.
- Zamora, N. A., Cook, R. A., Konz, R. C., and Consolazio, G. R. (2003), Behavior and Design of Headed and Unheaded Grouted Anchors Loaded in Tension, *ACI Structural Journal*, Vol. 100, No. 2, pp. 222-230.