

# Steel Plate Girder Diaphragm and Cross Bracing Loads

**FDOT Contract No. BDK80 977-20**  
**Final Report**

May 2014

Jawad H. Gull, Florida International University  
Atorod Azizinamini, Ph.D., P.E., Florida International University

## **DISCLAIMER**

The opinions, findings, and conclusions expressed in this publication are those of the authors and not necessarily those of the State of Florida Department of Transportation

# CONVERSION TABLES

## Approximate conversion to SI Units

Symbol	When you know	Multiply by	To find	Symbol
<b>Length</b>				
<b>in</b>	inches	25.4	millimeters	mm
<b>ft</b>	feet	0.305	meters	m
<b>yd</b>	yards	0.914	meters	m
<b>mi</b>	miles	1.61	kilometers	km
<b>Area</b>				
<b>in<sup>2</sup></b>	square inches	645.2	square millimeters	mm <sup>2</sup>
<b>ft<sup>2</sup></b>	square feet	0.093	square meters	m <sup>2</sup>
<b>yd<sup>2</sup></b>	square yard	0.836	square meters	m <sup>2</sup>
<b>ac</b>	acres	0.405	hectares	ha
<b>mi<sup>2</sup></b>	square miles	2.59	square kilometers	km <sup>2</sup>
<b>Volume</b>				
<b>fl oz</b>	fluid ounces	29.57	milliliters	mL
<b>gal</b>	gallons	3.785	liters	L
<b>ft<sup>3</sup></b>	cubic feet	0.028	cubic meters	m <sup>3</sup>
<b>yd<sup>3</sup></b>	cubic yards	0.765	cubic meters	m <sup>3</sup>
<b>Mass</b>				
<b>oz</b>	ounces	28.35	grams	g
<b>lb</b>	pounds	0.454	kilograms	kg
<b>T</b>	short tons (2000 lb)	0.907	megagrams (or "metric ton")	Mg (or "t")
<b>Temperature</b>				
<b>°F</b>	Fahrenheit	5 (F-32)/9 or (F-32)/1.8	Celsius	°C
<b>Illumination</b>				
<b>fc</b>	foot-candles	10.76	lux	lx
<b>fl</b>	foot-Lamberts	3.426	candela/m <sup>2</sup>	cd/m <sup>2</sup>
<b>Force and Pressure or Stress</b>				
<b>lbf</b>	pound force	4.45	newtons	N
<b>lbf/in<sup>2</sup></b>	pound force per square inch	6.89	kilopascals	kPa

### Approximate conversion to US Customary Units

Symbol	When you know	Multiply by	To find	Symbol
<b>Length</b>				
mm	millimeters	0.039	inches	in
m	meters	3.28	feet	ft
m	meters	1.09	yards	yd
km	kilometers	0.621	miles	mi
<b>Area</b>				
mm <sup>2</sup>	square millimeters	0.0016	square inches	in <sup>2</sup>
m <sup>2</sup>	square meters	10.764	square feet	ft <sup>2</sup>
m <sup>2</sup>	square meters	1.195	square yards	yd <sup>2</sup>
ha	hectares	2.47	acres	ac
km <sup>2</sup>	square kilometers	0.386	square miles	mi <sup>2</sup>
<b>Volume</b>				
mL	milliliters	0.034	fluid ounces	fl oz
L	liters	0.264	gallons	gal
m <sup>3</sup>	cubic meters	35.314	cubic feet	ft <sup>3</sup>
m <sup>3</sup>	cubic meters	1.307	cubic yards	yd <sup>3</sup>
<b>Mass</b>				
g	grams	0.035	ounces	oz
kg	kilograms	2.202	pounds	lb
Mg (or "t")	megagrams (or "metric ton")	1.103	short tons (2000 lb)	T
<b>Temperature</b>				
°C	Celsius	1.8C+32	Fahrenheit	°F
<b>Illumination</b>				
lx	lux	0.0929	foot-candles	fc
cd/m <sup>2</sup>	candela/m <sup>2</sup>	0.2919	foot-Lamberts	fl
<b>Force and Pressure or Stress</b>				
N	newtons	0.225	pound force	lbf
kN	Kilonewtons	0.225	kilopound	kip
kPa	kilopascals	0.000145	kilopound per square inch	ksi
kPa	kilopascals	0.145	pound force per square inch	lbf/in <sup>2</sup>

# TECHNICAL REPORT DOCUMENTATION PAGE

1. Report No.		2. Government Accession No.		3. Recipient's Catalog No.	
4. Title and Subtitle Steel Plate Girder Diaphragm and Cross Bracing Loads				5. Report Date May 2014	
				6. Performing Organization Code	
7. Author(s) Jawad H. Gull, Atorod Azizinamini (PI)				8. Performing Organization Report No.	
9. Performing Organization Name and Address 10555 W. Flagler Street, EC 3680 Miami, FL 33174 USA				10. Work Unit No. (TRAIS)	
				11. Contract or Grant No. BDK80-977-20	
12. Sponsoring Agency Name and Address Florida Department of Transportation 605 Suwannee Street Tallahassee, FL 32399 USA				13. Type of Report and Period Covered Final Report Jun. 2011-May 2014	
				14. Sponsoring Agency Code	
15. Supplementary Notes					
<p>16. Abstract</p> <p>The wide spectrum of options available to designers for analyzing and determining cross-frame forces can be a source of problems because different options may not result in similar solutions. The main objective of this project was to develop a set of recommendations and procedures and instructions to address analysis, design, and construction issues related to braces in steel I-girder bridges.</p> <p>Different methods that can be used to calculate brace loads are categorized and discussed in detail to identify the strengths and limitations of each method. The traditional 2D-grid analyses that are often used by commercial software packages ( such as MDX and DESCUS) does not take into account the full warping stiffness, resulting in underestimation of torsional stiffness of the girders. Although improved 2D-grid analyses may result in an improved representation of the full warping stiffness, these models are generally applicable to a no-load fit condition for cross-frames or diaphragms. The procedure by which 2D-grid analyses can be used for calculating cross-frame forces and other structural responses of bridges detailed with dead load detailing methods (erected fit and final fit) are described. It has been found that performance of improved and traditional 2D-grid analyses also depends on the framing layout (contiguous or staggered). Improved 2D-grid analyses are preferred for calculating the cross-frame forces because of the satisfactory performance for most of the framing layouts. A relatively simple method of simulating lack-of-fit is introduced in this report which makes use of models using three-dimensional (3D) finite element method (FEM). Although past studies have recommended using initial strain to simulate lack-of-fit in the cross-frames, this method can be tedious and complex. The proposed method makes use of element birth and death techniques to activate or deactivate the cross-frame elements to obtain a measure of the force or deformation at specific desired stages. The element birth and death method is generally more simple than the initial-strain methods with the essentially the same level of accuracy. Finally, different options for framing layouts, detailing methods, cross-frame configurations, and design methods for sizing the cross-frame members are discussed.</p>					
17. Key Word Steel bridges, Bridge design, Diaphragms (Engineering), Girder bridges, Cross-frames, Structural connection, Traffic loads				18. Distribution Statement No restrictions.	
19. Security Classif. (of this report) Unclassified		20. Security Classif. (of this page) Unclassified		21. No. of Pages 149	22. Price

## **ACKNOWLEDGEMENTS**

The authors would like to thank the Florida Department of Transportation (FDOT) and specifically Project Manager, Dennis Golabek.

## EXECUTIVE SUMMARY

From a stability perspective, the most critical stage in the life of a steel bridge usually occurs during the construction stage during the placement of the concrete deck. Cross-frames or diaphragms are critical elements to prevent the failure of bridge girders during the deck casting. There are a large number of methods of analysis to determine the design forces in cross-frames and size their members; however, each method of analysis can predict different design forces in cross-frames. Designers must choose from a number of alternatives for the design of cross-frames or diaphragms. A challenging situation has consequently ensued, where different approaches can result in significantly different outcomes.

The main objective of this project was to improve the uniformity in the design methodology for cross-frames or diaphragms, by developing a set of recommendations and procedures for addressing some of the analysis, design, and construction issues for these critical bracing elements. Further, the focus of proposed methodology is to develop recommendations that avoid the necessity of using complicated three-dimensional analyses.

Functions of cross-frame and sources of cross-frame forces in different bridge configurations are discussed to categorize different methods of analysis for calculating cross-frame forces. The benefits and limitations of different analysis methods are tabulated, and specific discrepancies in the methods used by different commercial software packages are described. The popularity of some of the methods of analysis and as well as the use of commercially-available software packages in United States, are outlined based on the results of a survey conducted by the Utah Department of Transportation.

It is important to note that the complexity of the methods of analysis is significantly impacted by the detailing methods for the bracing systems in bridges with skewed supports. Geometrical effects with the support skew lead to girder twist even in straight bridge systems. As a result, the cross-frames must be detailed for assembly into the bridge system at a particular load condition. The specific load condition that cross-frames are usually detailed for fit up is either in the i) no-load condition, ii) erected-fit condition (sometimes referred to as steel-dead-load-only condition), or iii) the final fit condition (sometimes referred to as full-dead-load condition).

Most 2D-grid analyses (traditional and improved) are generally applicable to the no-load fit detailing method. An overview is provided in this report of procedures by which 2D-grid analyses can be used for calculating cross-frame forces and other structural responses of bridges detailed with the other dead load detailing methods (erected fit and final fit). Cross-frame forces for erected fit detailing at the total dead

load stage are evaluated from 2D-grid analyses by applying only the concrete dead load to the system of girders and cross-frames. The cross-frame forces for the final fit detailing method at the steel dead load stage can be obtained by reversing the sign of the cross-frame forces obtained for the erected fit detailing method at the total dead load stage. The performance of improved and traditional 2D-grid analyses also depends on the framing layout of the braces (contiguous or staggered). However, improved 2D-grid analysis is recommended for calculating cross-frame forces because of its satisfactory performance for most of the framing layouts. A simplified 3D finite element method (FEM) analyses is introduced for simulating lack-of-fit and calculating cross-frame forces for final fit detailing method. A new concept is introduced for the 3D FEM analysis using element birth and death techniques to activate or deactivate the cross-frames at various levels of the analysis to simulate lack-of-fit. The use of the element birth and death techniques is generally simpler compared to using initial strain and evaluates cross-frame forces with same accuracy.

Different options for framing layouts, detailing methods, cross-frame configurations, and design methods for sizing the cross-frame members are described as well as a discussion of the advantages and disadvantages of different framing layouts. Lean-on bracing techniques and other cross-frame configurations studied by University of Texas, Austin, are discussed in detail. Finally, two design approaches for sizing the cross-frame members are discussed.



# TABLE OF CONTENTS

<b>DISCLAIMER</b> .....	<b>ii</b>
<b>CONVERSION TABLES</b> .....	<b>iii</b>
<b>TECHNICAL REPORT DOCUMENTATION PAGE</b> .....	<b>v</b>
<b>ACKNOWLEDGEMENTS</b> .....	<b>vi</b>
<b>EXECUTIVE SUMMARY</b> .....	<b>vii</b>
<b>LIST OF FIGURES</b> .....	<b>xi</b>
<b>LIST OF TABLES</b> .....	<b>xiv</b>
<b>1 Introduction</b> .....	<b>1</b>
1.1 Problem Statement .....	3
1.2 Objective .....	3
1.3 Organization of the Report.....	3
<b>2 Methods of Analysis and Design of Cross-Frames and Diaphragms</b> .....	<b>5</b>
2.1 Functions of Cross-Frames and Diaphragms .....	5
2.2 Types of Forces in Cross-Frames and Diaphragms .....	8
2.3 Classification of Bridges .....	9
2.4 Methods of Analysis .....	9
2.4.1 Hand Methods of Analysis.....	10
2.4.2 Line-Girder (1D) Analysis.....	21
2.4.3 Traditional 2D-Grid or Grillage Methods.....	29
2.4.4 Traditional 2D-Frame Methods .....	33
2.4.5 Improved 2D-Grid Method .....	33
2.4.6 Plate and Eccentric Beam Models .....	38
2.4.7 Traditional 3D-Frame Methods .....	39
2.4.8 Thin-Walled Open-Section (TWOS) 3D-Frame Methods.....	39
2.4.9 3D Finite Element Analysis (FEA) Methods.....	42
2.5 Summary .....	45
<b>3 Simplified Methods of Analysis for Different Detailing Methods</b> .....	<b>46</b>
3.1 Description of Structures Used for Comparison of Methods Analysis.....	49
3.2 Erected Fit Detailing Method.....	51
3.2.1 Methods of Analysis .....	51
3.2.2 Comparison of Different Methods of Analysis.....	53
3.3 Final Fit Detailing Method.....	63
3.3.1 Methods of Analysis .....	63
3.3.2 Comparison of Different Methods of Analysis.....	70
3.4 Summary .....	74
<b>4 Design Approaches for Sizing Cross-frames</b> .....	<b>76</b>
4.1 Framing Layout.....	77
4.1.1 Straight Bridges with Skew $< 20^\circ$ .....	77
4.1.2 Straight Bridges with Skew $\geq 20^\circ$ Equal for All Support.....	78
4.1.3 Straight Bridges with Skew $\geq 20^\circ$ Not Equal for All Support.....	82
4.1.4 Horizontally Curved Bridges .....	83
4.2 Detailing Methods.....	83
4.2.1 Straight Bridges with Skew $< 20^\circ$ .....	84
4.2.2 Horizontally Curved Bridges .....	85
4.3 Cross-frame Configuration .....	86
4.3.1 Lean-on Bracing.....	88

4.4	Design Approaches for Sizing Cross-Frame Members .....	91
4.5	Design of Brace to Meet AASHTO LRFD Specification.....	91
4.5.1	Straight Bridges with Skew $< 20^\circ$ .....	91
4.5.2	Straight Bridges with Skew $\geq 20^\circ$ .....	92
4.5.3	Horizontally Curved Bridges .....	92
4.6	Design of Brace to Meet AISC Requirements.....	93
<b>5</b>	<b>Recommendations .....</b>	<b>96</b>
5.1	Detailing Method .....	96
5.1.1	Straight Bridges with Skew $\geq 20^\circ$ .....	96
5.1.2	Horizontally Curved Bridges .....	96
5.2	Methods of Analysis .....	96
5.2.1	Straight Bridges with Skew $< 20^\circ$ .....	96
5.2.2	Straight Bridges with Skew $\geq 20^\circ$ .....	96
5.2.3	Horizontally Curved Bridges .....	97
5.3	Calculation of Camber .....	97
5.3.1	Straight Bridges with Skew $\geq 20^\circ$ .....	97
5.3.2	Horizontally Curved Bridges .....	98
	<b>References .....</b>	<b>99</b>
	<b>Appendix A: DOT Survey .....</b>	<b>102</b>
A.1	States Having Guidelines for Calculating Forces in Cross-frames.....	102
A.2	States Having Design, And Detailing Construction Guideline for Addressing Layover of Cross-Frame In The Case Of Straight, Curved and/or Skewed Bridges.....	105
A.3	Summary of Documents Referred By Different DOTs .....	107
A.3.1	Idaho DOT .....	107
A.3.2	Kansas DOT .....	109
A.3.3	Nevada DOT .....	109
A.3.4	Texas DOT.....	109
A.3.5	Wisconsin DOT .....	110
A.4	QUESTIONNAIRE .....	112
	<b>Appendix B: International Survey .....</b>	<b>114</b>
	<b>Appendix C: Analysis using MDX .....</b>	<b>115</b>
C.1	Bridge A.....	115
C.2	Bridge B.....	117
	<b>Appendix D: Design Example .....</b>	<b>120</b>
	<b>Appendix E: Girder and cross frame stiffness matrix .....</b>	<b>131</b>
E.1	Girder Stiffness Matrix .....	131
E.1.1	Traditional.....	131
E.1.2	Improved.....	132
E.2	Cross-frame Stiffness Matrix .....	133
E.2.1	Traditional.....	133
E.2.2	Improved.....	134
E.3	Comparison of results using improved and traditional cross frame matrix .....	135

## LIST OF FIGURES

Figure 2.1: Determination of the uniformly distributed load $F_l$ .	12
Figure 2.2: Fundamental model serving as the base case for the development of torsional bracing equations.	16
Figure 2.3: Curved girder subjected to a uniform major-axis bending moment.	23
Figure 2.4: Interaction of forces in a curved girder system.	25
Figure 2.5: Nationwide use of V-Load method (Green=Method Used, Red=Method Not Used, White=Not participated in Survey or other)	29
Figure 2.6: Schematic representation of the general two-node element implemented in computer programs for 2D-grid analysis of I-girder bridges.	30
Figure 2.7: 2D-grid model of Bridge XICCS7.	30
Figure 2.8: Nationwide use of DESCUS (Green=Method Used, Red=Method Not Used, White=Not participated in Survey or other).	32
Figure 2.9: Schematic representation of the general two-node element implemented in computer programs for 2D frame analysis of I-girder bridges.	33
Figure 2.10: Schematic representation of the plate-and-eccentric-beam model.	38
Figure 2.11: Schematic representation of a general two-node 3D TWOS frame element implemented in computer programs of I-girder bridges.	40
Figure 2.12: Example of recommended 3D FEA modeling approach on a segment of a three-I-girder bridge unit.	44
Figure 3.1: Erected fit and final fit detailing methods	48
Figure 3.2. Framing plan and girder sizes of the Bridge A.	49
Figure 3.3. Framing plan and girder sizes of the Bridge B.	50
Figure 3.4. Framing plan and girder sizes of the Bridge C.	50
Figure 3.5. Comparison of layovers calculated by different analysis method for Girder 1 of Bridge A..	54
Figure 3.6. Comparison of layovers calculated by different analysis method for Girder 1 of Bridge B..	55
Figure 3.7. Comparison of vertical deflection calculated by a different analysis method for Bridge A. .	57
Figure 3.8. Comparison of vertical deflection calculated by a different analysis method for Bridge B. .	57
Figure 3.9. Comparison of vertical reactions calculated by different analysis methods for Bridge A. ....	58
Figure 3.10. Comparison of vertical reactions calculated by a different analysis methods for Bridge B.	59

Figure 3.11. Comparison of flange lateral bending stress calculated by different analysis methods in Girder 8 of Bridge A—erected fit at the TDL stage. ....	60
Figure 3.12. Comparison of flange lateral bending stress calculated by different analysis methods in Girder 4 of Bridge B—erected fit at the TDL stage. ....	61
Figure 3.13. Comparison of cross-frame forces calculated by a different analysis method for Bridge A—erected fit at the TDL stage. ....	62
Figure 3.14. Comparison of cross-frame forces calculated by different analysis method for Bridge B—erected fit at the TDL stage. ....	62
Figure 3.15. Configurations to calculate initial strain in the cross-frames that are perpendicular to girder web. ....	66
Figure 3.16: Configurations to calculate initial strain in the cross-frames that are parallel to skew .....	68
Figure 3.17. Application of concrete dead load on girders after killing cross-frame elements. ....	69
Figure 3.18. Removal of concrete dead load from girders after making cross-frame elements alive. ....	70
Figure 3.19. Comparison of layovers calculated by different analysis methods—final fit at the SDL stage. ....	71
Figure 3.20. Comparison of component of deflection due to lack-of-fit ( $D_{Y2}$ ) calculated by different analysis methods. ....	72
Figure 3.21. Comparison of change in reactions due to lack-of-fit ( $R_{Y2}$ ) calculated by different analysis method for Bridge A. ....	72
Figure 3.22. Comparison of flange lateral bending stress calculated by different analysis methods. ....	73
Figure 3.23. Comparison of cross-frame forces calculated by different analysis methods. ....	73
Figure 4.1. Framing layout for straight bridges with skew less than 20 degrees. ....	77
Figure 4.2. Framing layout for straight bridges having skew greater than 20 degrees equal for all supports .....	78
Figure 4.3: Different cross-frame orientations. ....	79
Figure 4.4: Layover for different cross-frame orientations- erected fit at the TDL stage .....	80
Figure 4.5: Bent plate and split pipe details. ....	81
Figure 4.6: Framing layout for straight bridges having unequal skews. ....	82
Figure 4.7: Framing layout for curved bridges. ....	83
Figure 4.8: Flow chart to guide designer to deal with skew bridges .....	85
Figure 4.9: Traditional and lean-on bracing line. ....	88
Figure 4.10: A skew bridge with lean-on bracing system .....	89

Figure 4.11: Lean-on bracing system in 19 <sup>th</sup> Street Bridge .....	90
Figure A.1: States having guidelines for calculating forces in cross-frames (Green = Yes, Red = No, White = Not participated) .....	103
Figure A.2: States having design, and detailing construction guideline for addressing layover of cross-frame in the case of straight, curved and/or skewed bridges (Green = Yes, Red = No, White = Not participated) .....	105
Figure A.3: Twist in girder connected by braces in skewed support bridge.....	108
Figure C.1: Framing plans and girder sizes of the Bridge A .....	115
Figure C.2: 2D Grid model of Bridge A in MDX.....	116
Figure C.3: Comparison of concrete dead load vertical deflection of Girder 5 of Bridge A obtained from different methods of analysis .....	117
Figure C.4: Framing plans and girder sizes of the Bridge B .....	118
Figure C.5: 2D Grid model of Bridge B in MDX.....	118
Figure C.6: Comparison of concrete dead load vertical deflection of Girder 5 of Bridge B obtained from different methods of analysis .....	119
Figure E.1: Flange lateral bending stress along length of girder 8 of Bridge A.....	135
Figure E.2: Cross frames forces in bottom chord of cross frames in bay 4 of Bridge A.....	135

## LIST OF TABLES

Table 2.1: Values of the C coefficient.....	27
Table 2.2: Strengths and limitation of V-Load method.....	27
Table 2.3: Strengths and limitations of 2D analysis.....	31
Table 2.4: Strengths and limitations of 3D FEM analysis.....	45
Table 3.1. Performance of traditional and improved 2D GA.....	74
Table 4.1: Stiffness of different cross-frame configuration.....	87
Table 5.1: Method of calculation of camber for different detailing methods.....	98
Table A.1: Summary of responses to question 1 of the survey.....	104
Table A.2: Summary of responses to question 2 of the survey.....	105
Table D.1: Girder radius and length.....	120
Table D.2: Location of intermediate cross frames.....	120

# 1 Introduction

The design and construction of steel bridges must consider safety of the structure at every stage throughout the life of the bridge. With regards to safety, one of the most critical stages in the life of a steel bridge is during the construction stage, particularly during the placement of the concrete deck. The stability of steel bridge girders are mainly ensured through providing cross-frames or diaphragms. Although these terms are often interchanged when discussing the braces, cross-frames typically consist of a trussed brace while diaphragms consist of either a stiffened plate or rolled beam brace. The AASHTO LRFD Bridge Design Specification defines the function of cross-frames as follows:

Cross-frame Function and Forces, According to AASHTO LRFD Bridge Design Specification

The purpose of cross-frames is defined by Section 6.7.4 of the specifications, which states:

*“Diaphragms or cross-frames may be placed at the end of the structure, across interior supports, and intermittently along the span.*

*The need for diaphragms or cross-frames shall be investigated for all stages of assumed construction procedures and the final condition. This investigation should include, but not be limited to, the following:*

- *Transfer of lateral wind loads from the bottom of the girder to the deck and from the deck to the bearings,*
- *Stability of the bottom flange for all loads when it is in compression,*
- *Stability of the top flange in compression prior to curing of the deck,*
- *Consideration of any flange lateral bending effects, and*
- *Distribution of vertical dead and live loads applied to the structure. “*

In the past, the maximum spacing of cross-frames was limited to 25 ft. This requirement, however, was removed when the AASHTO LRFD was introduced, primarily due to fatigue concerns around cross-

frame and diaphragm locations. The specification provides the following explanation in its commentary for this design change.

*“C6.7.4.1- The arbitrary requirement for diaphragms spaced at not more than 25.0 ft. in the AASHTO Standard Specifications has been replaced by a requirement for rational analysis that will often result in the elimination of fatigue-prone attachment details.”*

With respect to forces that the cross-frame should be designed for, Section 6.7.4 of the AASHTO LRFD Specifications states:

*“...At a minimum, diaphragms and cross-frames shall be designed to transfer wind loads according to the provisions of Article 4.6.2.7 and shall meet all applicable slenderness requirements in Article 6.8.4 or Article 6.9.3. Diaphragm and cross-frame members in horizontally curved bridges shall be considered to be primary members...”*

As noted above, the cross-frames, at a minimum, are required to be designed for wind loads and slenderness requirements. However, as is discussed later in this section, additional considerations should be taken into account to adequately design cross-frames.

There is a vast amount of information with respect to the design and construction of cross-frames or diaphragms. There are a variety of different methods of analysis that can be used to estimate design forces in cross-frames. The variability of the different methods for predicting the magnitude and distribution of the forces can be significant. Both simple and detailed methods of analysis are provided in the literature. AASHTO NSBA steel bridge collaboration has recently published [1] a document that summarizes and provides guidelines for the available methods of analysis in steel girder bridges. While designers can benefit from the wide spectrum of options for analyzing and determining cross-frame forces, not having a definitive solution to the problem can also become a potential source of problems. In most situations, providing an array of options gives designers choices and alternatives. This approach sounds acceptable, if the various options result in similar solutions. However, this is not the generally the case with regards to the problem with cross-frame forces since in many situations, the different methods of analysis result in different magnitudes and distribution of the forces.



## **1.1 Problem Statement**

As noted in the previous section, there are a number of alternatives for the design and construction of cross-frames and diaphragms from which a designer can choose. However, because the different alternatives can result in significantly different outcomes, designers may face a dilemma with regards to the question, “What is the best or even the correct approach?”

## **1.2 Objective**

The main objective of this project is to develop a set of recommendations and procedures to be used in the analysis, design and construction issues related to cross-frames and diaphragms so that improved uniformity can result in the design of bracing systems for various bridge geometries. This objective should prevent cases where similar bridges are observed to have wide variability in connection details etc. Attempts were made to develop recommendations that avoid the use of three-dimensional analyses, unless aspects in the structural system and/or geometry demand such complexity. The investigation addressed the use of cross-frames and diaphragms in:

- a) Straight I-Girder Bridges
- b) I-Girder Bridges with Skewed Supports
- c) Curved I-Girder Bridges

## **1.3 Organization of the Report**

The report is organized in five chapters. Chapter 2 discusses functions of cross-frame and sources of cross-frame forces in different bridge configurations to categorize different methods of analysis. Different methods that can be used to calculate brace forces are categorized and discussed in detail to provide strengths and limitations of each method. Specific discrepancies in the methods used by different commercial software are described. The chapter also outlines of some of the methods of analysis and commercial software in United States with an overview of software usage based on the survey conducted by Utah Department of Transportation.

Chapter 3 describes association between methods of analysis and detailing methods for straight skewed bridges. The traditional 2D-grid (used by popular commercial software MDX and DESCUS) and improved 2D-grid analyses are generally applicable to no-load-fit detailing method. The chapter describes the procedure by which 2D-grid analyses can be used for calculating cross-frame forces and other structural responses of bridges detailed with dead load detailing methods (erected-fit and final-fit). Cross-frame forces for erected fit detailing at the total dead load stage are evaluated from 2D-grid

analyses by applying only concrete dead load to the system of girders and cross-frames. Cross-frame forces for the final-fit detailing method at steel dead load can be obtained by reversing the sign of cross-frame forces obtained for the erected-fit detailing method at the total dead load stage. Results from the study showed that the performance of improved and traditional 2D-grid analysis also depends on the framing layout (contiguous or staggered). However, it is recommended using the improved 2D-grid analysis for calculating cross-frame forces because of its satisfactory performance for most of the framing layouts. This chapter also outlines a simplified 3D finite element method (FEM) analyses for simulating lack-of-fit and calculating cross-frame forces for final fit detailing method. The 3D FEM method uses birth and death cross-frame elements to simulate lack-of-fit. In general, the use of birth and death cross-frames is simpler compared to using initial strain and evaluate cross-frame forces with same accuracy.

Chapter 4 discusses different options for framing layouts, detailing methods, cross-frame configurations and design methods for sizing the cross-frame members. Section 4.1.3 discusses the advantages and disadvantages of the framing layout with intermediate cross-frames parallel to skewed supports and the associated split pipe connection detail. Section 4.2 summarizes the research conducted on the detailing methods. Section 4.3 discusses the lean-on bracing and other cross-frame configurations studied at the University of Texas Austin. This chapter finally discusses the two design approaches for sizing the cross-frame members.

## 2 Methods of Analysis and Design of Cross-Frames and Diaphragms

### 2.1 Functions of Cross-Frames and Diaphragms

Cross-frames and diaphragms serve a number of important functions in steel I-girder bridges. It is essential to identify these various functions as a first step in categorizing any methods for their analysis and design. The functions of cross-frames and diaphragms are summarized as follows:

- Provide geometric control during erection and deck placement. This includes achieving target girder spacing, girder plumbness or layover, and girder vertical alignment (relative elevations of the girders) within acceptable tolerances. In addition, this includes achieving target deck cross-slopes within acceptable tolerances.
- Provide a means of “pre-twisting” the girders in the opposite direction to offset the girder layover under a selected dead load condition in the completed structure. This “pre-twisting” is achieved via detailing of the cross-frames for Steel Dead Load Fit (SDLF), Total Dead Load Fit (TDLF), or theoretical fit-up (without forcing) under other intermediate dead load conditions.
- Control potential problematic differential vertical displacements between girders during the deck placement, providing the ability achieve deck thicknesses within tolerances.
- Distribute dead loads between the girders during steel erection and during placement of the deck and other appurtenances.
- Connect the girders together to form a system to stabilize one another and to resist torsional loads.
- Provide lateral support to fascia girders to reduce the torsional (i.e., flange lateral bending) effects of eccentric loads from deck overhang brackets during construction.
- Provide lateral support to the girder top flanges prior to structural participation from the deck such that flange lateral bending moments from wind, skew and/or horizontal curvature are reduced.
- Provide lateral support to the girder bottom flanges throughout the life of the bridge (ranging from the erection of the steel, to the final in-service condition, to future rehabilitation efforts such as redecking), such that flange lateral bending moments from wind, skew and/or horizontal curvature are reduced.
- Provide stability to the girder top flanges in compression prior to structural participation from the deck.
- Provide stability to the girder bottom flanges in compression throughout the life of the bridge (ranging from the erection of the steel, to the final in-service condition, to future rehabilitation efforts such as redecking).
- Assist the deck in distributing live loads between the girders.
- Work with the deck to reduce transverse deck stresses. (Although measured cross-frame strains in service are often relatively small, if large live load cross-frame forces are calculated in a structural analysis, equilibrium still must be satisfied, such that to some extent, larger forces would be expected in the deck if for instance, the cross-frames were removed.)

- Transfer lateral wind loads, and other potential lateral loads such as from vehicle collision, from the bottom of the fascia girders to the deck, and from the deck to the bearings.
- Transfer lateral earthquake loads from the deck to the bearings.
- Provide support for utilities and walkways.
- Provide end support for deck expansion dams.
- Provide ability for jacking of bridges during bearing replacement.
- In skewed bridges, provide additional transverse paths for transfer of vertical loads to the supports. These transverse paths may or may not be considered beneficial to the design, depending on the perspective that one takes as well as the magnitude of the forces generated in the cross-frames or diaphragms. However, the cross-frames and diaphragms make the girders work together as a three-dimensional structural system.
- In curved bridges, provide a transverse load path essential to the ability of the bridge to resist the effects of the horizontal curvature. (Regardless of the torsional properties of the girders, a wide overall structural system will be more efficient in resisting torsion than the individual girders acting in isolation.)
- At skewed cross-frame or diaphragm connections to the girders, induce coupling between the girder major-axis bending rotations and girder twist rotations (layovers).
- In skewed and/or curved bridges, induce coupling between girder twists (layovers) and girder differential vertical deflections due to major axis bending.

Although the cross-frames and diaphragms serve a number of important functions in the life of the bridge, accurately estimating the design forces from the structural analysis is a very difficult task. As a result, many owners and design organizations have to developed and utilize standard cross-frame or diaphragm details that may be applied for a specified range of bridges. As such, many of the functions typically are accomplished without any explicit calculation of the associated forces. For straight non-skewed bridges, the proportioning of the cross-frame or diaphragm components traditionally has been accomplished by various simple rules of thumb, and by the use of very basic analysis models to determine the force demands. For instance, the AASHTO LRFD Specifications [2] require:

- A minimum thickness of 0.3125 inches (5/16 inches) on all steel components with the exception of the web thickness of rolled beams or channels and closed ribs of orthotropic decks (Article 6.7.3).
- A maximum slenderness ratio of  $\ell/r = 140$  for primary tension members subjected to stress reversals,  $\ell/r = 200$  for primary tension members not subjected to stress reversals, and  $\ell/r = 240$  for secondary members (Article 6.8.4).
- A maximum slenderness ratio of  $K\ell/r = 140$  for secondary members loaded in compression (Article 6.9.3), and a maximum slenderness ratio of  $K\ell/r = 120$  for primary members loaded in compression (Article 6.9.3). AASHTO Article 4.6.2.5 indicates that, in the absence of a more refined analysis,  $K$  should be taken as 1.0 for single angles (largely because AASHTO now

provides a separate “equivalent”  $KL/r$  for design of single angles), regardless of the end connection, but otherwise,  $K = 0.75$  may be used for members with bolted or welded end connections at both ends.

- Diaphragms and cross-frames should be as deep as practicable, but as a minimum should be at least 0.5 of the beam depth for rolled beams and 0.75 of the girder depth for plate girders (Article 6.7.4.2).

For straight non-skewed I-girder bridges, and even for many straight skewed I-girder bridges, a common traditional practice is to proportion the cross-frame and diaphragm components based on the above requirements along with the force requirements solely from a lateral wind load analysis [3]; Mertz [3] indicates:

“Primarily based upon the difficulty, if not impossibility, associated with accurately estimating cross-frame forces from the simple live-load distribution-factor approach to girder design, in which longitudinal behavior is uncoupled from transverse behavior, live-load forces are ignored when proportioning cross-frame diaphragm members. In addition, field measurements of strains in cross-frame members of in-service bridges reveal relatively moderate stress under random and design live load.”

The AASHTO LRFD Specifications [2] recognize this practice by indicating “At a minimum, diaphragms and cross-frames shall be designed to transfer wind loads according to the provisions of Article 4.6.2.7 and shall meet all applicable slenderness requirements in Article 6.8.4 and Article 6.9.3.” However, AASHTO Article 6.7.4.1 goes on to state “If permanent cross-frames or diaphragms are included in the structural model used to determine force effects, they shall be designed for all applicable limit states for the calculated force effects.” In addition, AASHTO Article 6.7.4.1 [2] recommends a general list of intermediate cross-frame functions to be considered in design, and Article 6.7.4.2 requires the consideration of specific actions in diaphragms and cross-frames at bearing lines. These requirements encompass the majority of the above listed functions.

Recently, Helwig & Yura [4] provided detailed recommendations for the calculation of both force and stiffness requirements in bridge diaphragms and cross-frames in straight bridges with and without skew based on girder stability bracing requirements. It is noted that in certain cases, the corresponding forces from these equations can be larger than those associated with the wind loads. A summary of key considerations in the stability bracing rules is provided in Section 4.6 of this report.

For horizontally curved I-girder bridges, the AASHTO LRFD Specifications [2] clearly recognize additional important effects:

- Diaphragm and cross-frame members in horizontally curved bridges shall be considered to be primary members (Article 6.7.4.1). NHI [5] points out that the cross-frame or diaphragm forces in straight bridges with skewed supports can be much higher than found in many curved girder bridges, and that these members serve essential functions, in spite of not being classified as primary members by the AASHTO Specifications.
- Cross-frames in horizontally curved bridges should contain diagonals and top and bottom chords (Article 6.7.4.2). NCHRP Report 725 [6] indicates that K-type cross-frames without top chords should be used with significant caution, since these types of cross-frames are highly flexible and ineffective without participation from the formwork or deck acting as a top chord.

Basically, bridge engineers and bridge engineering organizations have commonly faced a dilemma of what effects must be calculated in the design of diaphragms and cross-frames, and when can standard cross-frames and diaphragm systems simply be specified for a range of bridge configurations. The advent of more sophisticated refined analysis methods (i.e., methods approximating the actual three-dimensional bridge response in various ways), has compounded this problem and has led to a wide range of situations where similar bridges are observed to have substantially different details. This is particularly the case for more highly skewed and/or sharply curved I-girder bridges.

## **2.2 Types of Forces in Cross-Frames and Diaphragms**

Analysis and design of cross-frames and diaphragms ideally requires:

- 1) Layout of the cross-frames or diaphragms in a manner that will allow them to satisfy their functions with good structural efficiency,
- 2) Identification of the significant potential force demands placed on these components by their various functions,
- 3) Development and execution of appropriate analysis models to calculate these demands, and
- 4) Proportioning of the members and connections of the cross-frames or diaphragms.

Given the functions listed in the previous section, the following is a list of potentially significant types of forces in cross-frames and diaphragms. The subsequent discussions identify particular cases where the different types of forces can be of major importance. The types of forces in cross-frames and diaphragms include:

- 1) Forces induced as a function of the detailing method.
- 2) Stability bracing forces.
- 3) Other non-composite dead load distribution forces, including eccentric loads from overhang brackets
- 4) Composite dead load distribution forces, including significant barrier loads, loads from signs, etc.
- 5) Live load forces.

- 6) Wind load forces prior to structural participation from the deck.
- 7) Wind load forces after the deck is in place and structurally active.
- 8) Forces due to vehicle collision.
- 9) Earthquake loads.
- 10) Vertical loads from deck expansion dams.
- 11) Jacking loads.
- 12) Utility and walkway loads.
- 13) Forces from restrained thermal movement.
- 14) Forces caused by rehabilitation of the bridge structure, such as redecking operations.
- 15) Forces due to substructure movement or support settlement.
- 16) In skewed bridges, additional distribution loads associated with the transverse load path(s) created by the cross-frames.
- 17) In skewed bridges, additional loads due to displacement compatibility with the girders, e.g., due to compatibility of deformations, both of the following induce girder twist rotations:
  - a. Rotation of skewed cross-frames about an axis parallel to the skew, and
  - b. Differential vertical displacement between two girder locations connected together by a cross-frame.
- 18) In curved bridges, the V-loads (a special type of distribution load specific to horizontal curvature effects).

### **2.3 Classification of Bridges**

Support skew and horizontal curvature can have a substantial influence on cross-frame and diaphragm forces. As such, the approaches to analysis and design of cross-frames and diaphragms can vary significantly depending on these attributes. Therefore, any categorization of methods of analysis and design of cross-frames and diaphragms needs to recognize the following bridge classifications:

- 1) Straight bridges with zero skew.
- 2) Skewed straight bridges.
- 3) Horizontally curved bridges with radial supports.
- 4) Horizontally curved bridges with skewed supports.

### **2.4 Methods of Analysis**

Various methods of analysis are available for the design of steel I-girder bridges, and specifically for the design of cross-frames and diaphragms. These include:

- 1) Various hand methods based on the simple application of statics, using statically determinate or simplified approximate structural analysis models. These types of models are applied commonly to estimate specific local effects on the cross-frames or diaphragms, such as the effects of eccentric loads from overhang brackets, vertical loads from expansion dams, jacking loads, utility and walkway loads, etc.
- 2) Line girder analysis (1D) methods.

- 3) Traditional 2D-grid or grillage methods.
- 4) Traditional 2D-frame methods.
- 5) Improved 2D-grid method.
- 6) Plate and eccentric beam models.
- 7) Traditional 3D-frame methods.
- 8) Thin-walled open-section (TWOS) 3D-frame methods.
- 9) 3D Finite Element Analysis (FEA) methods.

The following subsections, adapted from the NCHRP 725 research [6], summarize the essential idealizations and approximations associated with each of these methods. In simple terms, the cross-frames and diaphragms generally participate as an important part of the structural system in transferring loads to the supports in any situation where the response is significantly three-dimensional. Hence, in many cases, analysis of the cross-frames and diaphragms is synonymous with analysis of the bridge superstructure.

## 2.4.1 Hand Methods of Analysis

### 2.4.1.1 Flange Lateral Bending due to Overhang Bracket Loads

One area where simple hand methods of analysis are common is in the calculation of the effects of eccentric loads from overhang brackets. The maximum internal flange lateral bending moment due to overhang bracket loads can be estimated in a given unbraced length of fascia girders using AASHTO Eq. C.10.3.4-2:

$$M_{\ell} = F_{\ell} L_b^2 / 12 \tag{1}$$

where  $F_{\ell}$  is a lateral uniformly distributed load imposed on the flange by the overhangs, calculated by dividing the moment from the distributed loads on the overhang by the depth of the overhang brackets (see Figure 2.1), and  $L_b$  is the distance between cross-frames. The above equation is based on the assumption of symmetrical boundary conditions for the flange lateral bending at the cross-frame locations. Correspondingly, the term in the numerator is basically the end moment for a fixed-fixed beam. In Eq. (1), the value 12 is sometimes changed to 10, to recognize the fact that the flange may not be fully fixed (per symmetry boundary conditions) at the cross-frame locations (the value 12 is used in all the NCHRP 725 calculations). In many situations, the highest levels of flange lateral bending stress occur at the cross-frame positions; therefore, the stresses calculated with Eq. 1 represent reasonable estimates for design.



The cross-frames or diaphragms act as effective rigid supports in the above idealized model, reducing the overall torsion of the girders, or lateral bending of the girder flanges, due to these actions. Based on Figure 2.1, the reaction that must be resisted by the cross-frames or diaphragms is the couple

$$T_l = F_v L_b e \tag{2}$$

where  $F_v$  is the resultant of the vertical load per unit length along the bridge supported by the overhang brackets,  $L_b$  is the unsupported length of the girders between the cross-frames (typically taken as the average of the two unbraced lengths on each side of the cross-frame when these lengths are not equal), and  $e$  is the position of the resultant load relative to the centerline of the fascia girder.

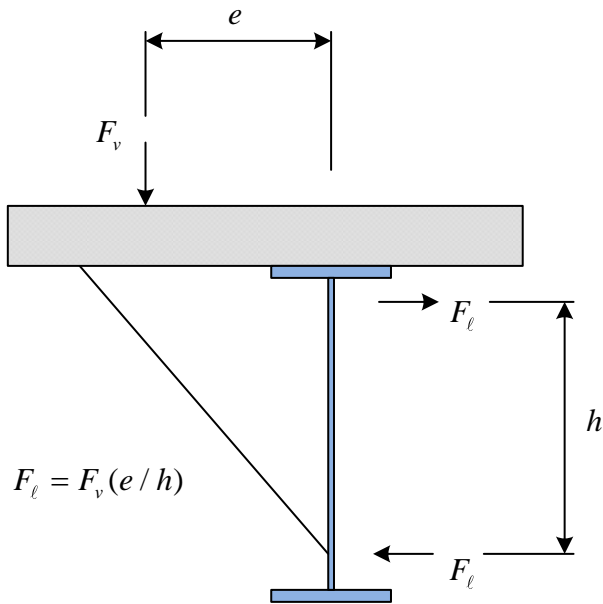
When considering concentrated loads on the overhangs ( $F_l$ ), for example from the wheel loads on a screed rail, one may wish to use the expression given in AASHTO LRFD Eq. C6.10.3.4-3:

$$M_l = \frac{F_l L_b}{8} \tag{3}$$

where  $F_l = F_v(e/h)$ , and  $e$  is the eccentricity of the concentrated load for calculating the girder flange lateral bending moments. That is, the concentrated load is placed at the mid-length between the cross-frame locations to maximize the corresponding estimate of the flange lateral bending. However, the maximum cross-frame or diaphragm forces are estimated as

$$T_l = F_v e \tag{4}$$

by positioning the load at the cross-frame or diaphragm.



**Figure 2.1: Determination of the uniformly distributed load  $F_l$ .**

#### 2.4.1.2 Flange Lateral Bending due to Horizontal Curvature

Comparable equations to the above are available for calculation of the girder flange lateral bending moments due to horizontal curvature effects. However, the determination of the cross-frame/diaphragm forces due to the couples transferred to them by the fascia and interior girders is somewhat more involved than just the calculation of the torques transferred to the cross-frames or diaphragms. This calculation is addressed below in the discussion of the V-load method extension of Line-Girder (1D) analysis methods.

#### 2.4.1.3 Flange Lateral Bending due to Wind

AASHTO [2] Article 4.6.2.7.1-1 recommends that the lateral wind load per unit length, applied to both flanges of the windward fascia girder for checking wind during steel erection, should be taken as(AASHTO LRFD Eq. C4.6.2.7.1-1):

$$W = \frac{\eta_i \gamma P_D d}{2}$$

(5a)

where  $\eta_I$  is the AASHTO load modifier addressing ductility, redundancy and operational importance specified in AASHTO Article 1.3.2.1,  $\gamma$  is the AASHTO load factor for a given loading combination,  $P_D$  is the design horizontal wind pressure specified in AASHTO Article 3.8.1, and  $d$  is the depth of the member. Once a deck that can provide horizontal diaphragm action is structurally active,  $W$  is no longer considered to be applied to the top flange of the upwind fascia girder. Rather, the Wind force from the upper half of the girder depth, the deck, vehicles, barriers and appurtenances is applied directly to the deck.

In cases where the deck or a flange-level lateral wind bracing is structurally active, the girder flange lateral bending in flanges not continuously supported by the deck can be calculated using AASHTO LRFD Eq. C4.6.7.1-2) as:

$$M_w = \frac{WL_b^2}{10} \tag{5b}$$

where  $L_b$  is the distance between the cross-frames/diaphragms, if the deck slab is structurally active. Otherwise, it is taken as the distance between the panel points of the flange-level lateral bracing truss system. One can observe that, in this case, AASHTO uses the coefficient of 10 in the denominator rather than 12 as in Eq. 1. In cases where the bridge does not have an active flange-level lateral bracing system or a deck, the girder flange lateral bending is calculated using AASHTO LRFD Eq. C4.6.7.1-3 as:

$$M_w = \frac{WL_b^2}{10} + \frac{WL^2}{8N_b} \tag{5c}$$

The second term in this equation is an estimate of the overall “global” lateral bending between the points of lateral support at the ends of the span  $L$  of all the flanges at a given level for the  $N_b$  girders in the bridge. This equation is based on the assumption that cross-frames or diaphragms act as struts in distributing the wind force on the windward fascia girder to the other girder flanges. If there are no cross-frames or diaphragms, the first term in Eq. (5c) should be taken as 0.0 and  $N_b$  should be taken as 1.0. It should be noted that Eqs. (5b) and (5c) do not correctly represent the behavior for the case of a bridge with a flange-level lateral bracing system with panel points at a spacing larger than that of the

cross-frames or diaphragms. This is a good example of the difficulty of specifying simplified analysis equations to address all possible structural arrangements. Generally, it is necessary for the bridge engineer to properly idealize the structure and correctly apply fundamental principles of equilibrium when estimating various force effects.

In the above flange loading cases, the horizontal wind force applied at each cross-frame or diaphragm location is calculated using AASHTO LRFD Eq. C4.6.2.7.1-4 as:

$$P_w = WL_b \tag{5d}$$

where  $L_b$  is the spacing between the diaphragms or cross-frames, typically taken as the average of the two adjacent lengths when these lengths are not equal.

#### 2.4.1.4 Flange Lateral Bending due to Skew Effects

Prior to the recommendations from NCHRP 725 [6], there has been limited guidance regarding the calculation of girder flange lateral bending moments due to skew effects when I-girder bridges are evaluated using a line-girder or a traditional 2D-grid analysis. In lieu of providing a predictor method, AASHTO LRFD [2] Article C6.10.1 provides a number of upper-bound estimates of the girder flange lateral bending stresses due to skew effects. These estimates are based on a limited evaluation of refined analysis results for skews approaching 60 degrees from normal and an average girder  $D/b_f$  ratio of approximately 4.0. (Interestingly, the girder flange lateral bending stresses are not necessarily reduced by increasing the girder flange widths.) In addition, Article C6.10.1 indicates, “An examination of cross-frame or diaphragm forces is also considered prudent in all bridges with skew angles exceeding 20 degrees.” However, no guidance is provided for the basic estimation of these forces.

For bridges with a skew index

$$I_s = \frac{w_g \tan \theta}{L_s} \tag{6}$$

greater than 0.30, where  $w_g$  is the width between the fascia girders normal to the girders,  $\theta$  is the maximum skew angle of the bearing lines, equal to zero for a bridge with no skew, and  $L_s$  is the smallest

span length adjacent to the bearing line under consideration, NCHRP 725 [6] recommends the use of an “improved” 2D-grid analysis as a minimum for the calculation of cross-frame or diaphragm forces. Once the cross-frame or diaphragm forces are determined from the structural analysis, NCHRP 725 recommends a specific statical procedure for estimating the girder flange lateral bending moments for analysis methods that do not provide the flange lateral bending stresses directly. The method steps or progresses along the length of each girder and considers the equivalent flange-level lateral loads from the cross-frames/diaphragms, horizontal curvature effects, overhang bracket eccentric loading effects, etc. The recommended NCHRP 725 procedures, and the meaning of the word “improved” are described below in the section *Improved 2D-Grid Method*.

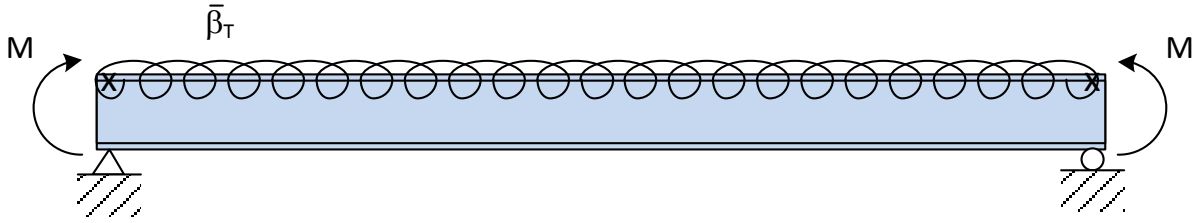
#### 2.4.1.5 Diaphragm and Cross-Frame Forces due to Stability Bracing Effects

Prior to the deck slab becoming structurally active, modern I-girder bridges typically do not utilize any flange level lateral bracing system (i.e., in-plan horizontal bracing near the top or bottom flange of the girders) for spans less than approximately 200 ft. For these structures, the stability bracing of the girders by the cross-frames and diaphragms is fundamentally a torsional bracing problem. The cross-frames and diaphragms tie the girders together so that any twisting of the girders is resisted by differential major-axis bending of the girders across the bridge cross-section.

From a stability bracing perspective, effective bracing must possess adequate stiffness and strength. For the stiffness requirements, the fundamental model used for the calculation of torsional bracing demands is the elastic eigenvalue buckling of a perfectly straight, perfectly-plumb I-section beam. Initial studies on the bracing focused on the case of a simply supported beam subjected to uniform bending moment subjected to rigid torsionally-simply supported (i.e., fork) end bracing conditions and restrained against twisting by a continuous torsional spring of stiffness  $\bar{\beta}_T$  [7]. This idealized case is illustrated in Figure 2.2. Yura et al. [8] expanded upon this research and developed detailed design requirements for both continuous and nodal (i.e., discrete grounded) beam torsional bracing. Their studies addressed the effects of cross-section distortion, moment gradient, position of loading, and location of the torsional brace relative to the member depth on the buckling behavior of I-section members. Yura [9] [10] and Helwig [4] provide a synthesis of the recommendations based on this research.

While the eigenvalue buckling analysis provides an indication of the stiffness behavior of stability bracing systems, the strength requirements must be conducted using a large-displacement analysis on an

initially imperfect system. Past studies [9] [10] and Helwig [4]) found that twice the ideal stiffness as determined from an eigenvalue analysis must be provided to control brace forces and deformations.



**Figure 2.2: Fundamental model serving as the base case for the development of torsional bracing equations.**

The detailed torsional brace stiffness and strength requirements developed by the above researchers can be summarized as follows. The central equation (representing the ideal brace stiffness – ie. perfectly straight member) for these developments is the following expression for the elastic lateral-torsional buckling resistance of a general I-section member with discrete or continuous torsional bracing along its length:

$$M_{cr} = \sqrt{(C_{bu}M_o)^2 + \frac{C_{bb}^2 EI_{eff} \bar{\beta}_T}{C_{iT}}} \tag{7a}$$

where:

$C_{bu} = C_b$  factor for the unbraced beam, i.e., the factor applied to  $M_o$  to account for moment gradient effects if there were zero intermediate bracing

$M_o =$  buckling capacity of the beam subjected to uniform moment if zero intermediate bracing were present

$C_{bb} = C_b$  factor for the critical unbraced segment of the braced beam

$I_{eff} = I_y$  for doubly symmetric sections

$= I_{yc} + \frac{t}{c} I_{yt}$  for singly symmetric sections

$c =$  distance between cross-section centroid and centroid of compression flange

$t$  = distance between cross-section centroid and centroid of tension flange

$I_{yc}$  = moment of inertia of the compression flange

$I_{yt}$  = moment of inertia of the tension flange

$C_{iT}$  = torsional bracing factor accounting for the effects of transverse load height

= 1.2 when the transverse loading is applied at the flange level in a way that is detrimental to the member stability (this occurs when the transverse loading is applied at the flange level and is directed toward the member shear center from the point of application)

= 1.0 otherwise

$\bar{\beta}_T$  = actual or equivalent continuous torsional bracing stiffness

=  $\frac{\beta_T n_T}{\alpha L}$  for equal-stiffness equally-spaced intermediate discrete nodal torsional braces

$\beta_T$  = intermediate nodal (discrete) torsional brace stiffness

$n_T$  = number of intermediate nodal torsional braces

$L$  = total beam span length between torsionally rigid end lateral braces

$\alpha = 0.75$  for a single mid-span torsional brace in beams subjected to centroidal loading (i.e., for beams with a single mid-span torsional brace in which there are no-load height effects)

= 1.0 for all other cases

The discrete torsional bracing stiffness and strength requirements recommended by Yura [10] and by Helwig [4] are derived from this equation by:

- Neglecting the contribution of the  $C_{bu}M_o$  term to the elastic LTB capacity  $M_{cr}$ ,
- Substituting  $\frac{\beta_T n_T}{L}$  for  $\bar{\beta}_T$
- Solving for the discrete torsional bracing stiffness  $\beta_T$  required to develop  $M_{cr}$  equal to the maximum moment developed throughout the span of the beam at the governing factored load level,  $M_{imax}$ ,
- Setting  $C_{iT}$  conservatively equal to 1.2, and
- Multiplying by 2.0, to double the “ideal stiffness” and control brace forces and deformations

These steps result in the required discrete torsional bracing stiffness

$$\beta_T^* = \frac{2.4LM_u^2}{n_T E I_{eff} C_{bb}^2} \quad (7b)$$

To estimate the torsional bracing strength demand, the torsional bracing initial geometric imperfection is assumed to be

$$\theta_o = \frac{L_b}{500h_o} \quad (7c)$$

where  $L_b$  is the assumed constant spacing between the cross-frames or diaphragms and  $h_o$  is the height between the mid-thickness of the flanges, the assumption that the torsional bracing initial imperfection due to the applied load is equal to  $\theta_o$ , and thus the required torsional bracing moment may be written as

$$M_{br} = \beta_T^* \theta_o = \frac{0.005LL_b M_u^2}{n_T h_o E I_{eff} C_{bb}^2} \quad (7d)$$

By substituting the relationship

$$L_b = L / (n_T + 1) \quad (7e)$$

and writing

$$\frac{\pi^2 E I_{eff}}{L_b^2} = 2P_{e,eff} \quad (7f)$$

where  $P_{e,eff}$  may be considered as an effective elastic lateral buckling load of the compression flange, Eq. 5d may be written in the form



$$M_{br} = 0.024 \left( \frac{n_T + 1}{n_T} \right) \left( \frac{M_{u\max} / C_{bb} h_o}{P_{e.\text{eff}}} \right) \left( \frac{M_{u\max}}{C_{bb}} \right) \quad (7g)$$

Equation 7g provides an important insight on the above estimate of the required moment capacity that the cross-frames or diaphragms must be designed for. If the equivalent compression flange force  $M_{u\max} / C_{bb} h_o$  is significantly smaller than the effective lateral buckling load of the compression flange  $P_{e.\text{eff}}$ , the required torsional bracing strength is substantially reduced. The commentary of the AISC Specification Appendix 6 takes this ratio equal to 1.0 to arrive at a simplified equation for the required moment taken by the torsional bracing that may be written equivalently as

$$M_{br} = 0.024 \left( \frac{n_T + 1}{n_T} \right) \left( \frac{M_{u\max}}{C_{bb}} \right) \quad (7h)$$

However, it should be noted that in many practical situations,  $(M_{u\max} / C_{bb} h_o) / P_{e.\text{eff}}$  is substantially smaller than 1.0, and thus Eq. (5g) provides a much smaller estimate for the moment that the cross-frames or diaphragms must be designed for.

Bishop et al. [11] observe that for cases in which the LTB resistance is governed by inelastic buckling, or by plastic buckling (i.e, the “plateau” of the LTB resistance curve), the bracing strength requirements tend to increase significantly as the maximum strength of the member is approached. This behavior is not predicted accurately by the above torsional bracing equations. However, Bishop et al. [11] observe that a bracing strength requirement of

$$M_{br} = 0.02M_u \quad (7i)$$

where  $M_u$  is the maximum moment within the unbraced lengths on either side of a brace location, provides a reasonable estimate of the maximum moment developed in the torsional bracing for non-seismic loading considerations. (Although in some cases, the required moment in the torsional bracing is larger than that indicated by Eq. (7i), the member is always within a close margin of reaching its maximum moment capacity when the torsional bracing moment becomes larger than this value.)

With regard to the design of bridge cross-frames or diaphragms in straight non-skewed bridges, the important conclusion that can be drawn from Eq. (7i) is that this equation can potentially place a larger force demand on the cross-frame or diaphragm members than lateral wind loading. Generally, the diaphragm and cross-frame members should be designed for the maximum of the requirements from the wind load analysis or from Eq. (7i). The engineer need not consider combined stability bracing and wind load effects, since the girder major axis bending moments associated with the maximum wind load combinations will tend to be significantly smaller than the corresponding factored moments under gravity load alone (as well as the corresponding girder elastic LTB moments).

Equation 7b may also be written in terms of the unbraced length  $L_b$  and the effective compression flange lateral buckling load as

$$\beta_T^* = 12h_o^2 \left( \frac{M_{u\max}/C_{bb}h_o}{P_{e.\text{eff}}} \right) \left( \frac{M_{u\max}/C_{bb}h_o}{L_b} \right) \frac{(n_T + 1)}{n_T} \quad (7j)$$

Similar to Eq. (7g), this equation provides useful insight into the behavior of the torsional bracing stiffness requirements. Based on an inspection of these requirements, one can conclude that typically bridge cross-frame and diaphragm systems have more than enough stiffness to brace the girders. Important cases that should be considered where this may not be the case include:

- Skewed cross-frames attached to girder connection plates by bent-plate details. The flexibility of the bent plate connection may substantially reduce the effective torsional bracing stiffness.
- Narrow I-girder systems in which global elastic LTB of the girder system is suspect.

It should be noted that AASHTO Article 6.6.1.3.1 requires that girder connection plates must be welded or bolted to both the compression and tension flanges of the cross-section. The use of a properly designed connection plate effectively eliminates any significant distortion of the girder cross-section at the brace point, and thus eliminates one source of torsional bracing flexibility. It should be noted that the overall torsional bracing stiffness is effectively achieved by the stiffness of the connection plate acting as a stiffener, the connection to the connection plate, the cross-frame or diaphragm, and the girder major-axis bending stiffnesses resisting torsion of the I-girder system, all acting in series. Therefore, the total torsional bracing stiffness is never larger than the smallest stiffness of these contributors. Yura

[10] and Helwig [4] summarize the idealizations that may be used to assess the provided torsional bracing stiffness for various details.

#### **2.4.2 Line-Girder (1D) Analysis**

A line-girder analysis is the most basic method used in the engineering of girder bridges. In this method, the bridge girders are analyzed individually, and their interaction with the cross-frames and diaphragms is ignored or accounted for only in a coarse fashion. The loads during steel erection are commonly taken as those acting directly on each girder, but various approaches are used for distributing the subsequent dead loads. NHI [12] suggests that when the width of the deck is constant, the girders are parallel and have approximately the same stiffness, and if the number of girders is not less than four, the permanent load of the wet concrete deck may be distributed equally to each of the girders in the cross-section (predicting concomitant, but often uncalculated, forces in the cross-frames). Article 4.6.2.2.4 of AASHTO [2] indicates that wearing surface and other distributed loads may be assumed uniformly distributed to each girder in the cross-section of curved steel bridges. However, NHI [5] emphasizes that heavier DC<sub>2</sub> line loads such as parapets, barriers, sidewalks or sound walls should not be distributed equally to all the girders. If the overhang widths and/or the concrete barrier loads are large, engineers commonly use the lever rule [2] to distribute the overhang and barrier loads to the girders. Alternatively, some state DOTs assign 60% of the barrier weight to the exterior girders and 40% to the adjacent interior girders [12]. If the lever rule is used, the portion of the dead load assigned to the fascia girders is increased, while the loads on the interior girders are reduced. In addition, NHI [12] indicates equal distribution of distributed loads can be suspect for skews larger than 10 degrees. All of these assumptions have corresponding statical implications on the dead load forces developed in the cross-frame members. Considering all these factors, the distributed dead loads were assigned to the girders based on tributary area in the 1D analyses conducted by NCHRP 725 [6]. Parapet loads were considered in the design of parametric study bridges in the NCHRP 725 [6] research, but these bridge designs were conducted using 2D-Grid and Plate-Eccentric Beam analysis procedures discussed subsequently.

Typically, various other supplementary calculations are added to basic line-girder estimates to account for important effects not inherently included in the 1D idealization. The next section summarizes calculations commonly utilized to extend the line-girder method to the analysis and design of horizontally curved I-girder bridges.

### 2.4.2.1 V-Load Method

The V-load method extends the capabilities of a 1D line-girder analysis to address horizontal curvature effects in I-girder bridges. The method was originally developed by Richardson, Gordon, and Associates (presently the Pittsburgh office of HDR Engineering, Inc.) and was published in the “*USS Structural Report, Analysis and Design of Horizontally Curved Steel Bridge Girders*” [13]. The V-load method has been used for more than four decades in the preliminary and final design of curved I-girder bridges. This section discusses the background of the method to highlight its attributes and applicability. The derivations are based on the work presented in Grubb [14] and Poellot [15].

Consider the simply-supported curved I-girder shown in Figure 2.3, which is subjected to a major-axis uniform bending moment,  $M$ , via forces applied at its ends. The corresponding flange axial forces,  $Q$ , are approximately equal to  $M/h$ , where  $h$  is the distance between the flange centroids. A differential element of the top flange with an arc length  $ds = R d\theta$  is extracted from the girder, where  $R$  is the horizontal radius of curvature of the girder. Figure 2.3b shows a free body diagram (FBD) of this flange segment. The longitudinal components of the forces,  $Q_x$ , cancel each other. However, the radial components

$$Q_y = \frac{M}{h} \frac{d\theta}{2} \tag{8}$$

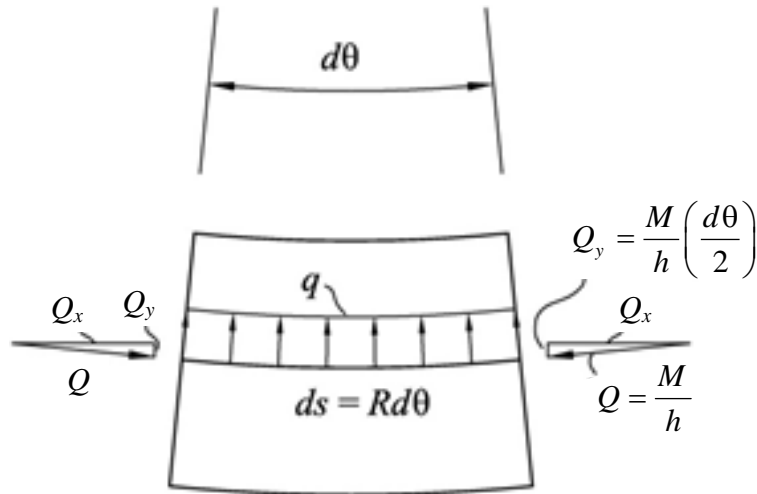
are additive. Therefore, a uniformly distributed internal force

$$q = \frac{2Q_y}{ds} = \frac{M}{Rh} \tag{9}$$

transferred via the web, is necessary to balance these components. Upon multiplying both sides of this equation by the radius  $R$ , one can observe that the flange axial force,  $Q$ , is equal to  $qR$ .



(a) Axial forces in the top flange due to uniform moment



(b) Free body diagram of the flange segment

**Figure 2.3: Curved girder subjected to a uniform major-axis bending moment.**

The above uniformly distributed force,  $q$ , subjects the flanges to lateral bending. Hence, in a two-girder system such as the one depicted in Figure 2.4a, the flanges behave like continuous-span beams in the lateral direction, while the cross-frames act like the continuous-span beam supports. The girders G1 and G2 in this figure are subjected to major-axis bending moments  $M_1(x)$  and  $M_2(x)$ , respectively, where  $x$  is the coordinate measured along the arc length of the girders. For equilibrium of the exterior girder at the first intermediate cross-frame in Figure 2.4b the reaction at the level of the cross-frame chords,  $H_1$ , must be approximately equal to  $q_1 L_{b1} h / h_{CF}$ , where  $h_{CF}$  is the depth between the centerline of the cross-frame chords and  $L_{b1}$  is the distance between cross-frames measured along the centerline of G1 (assumed constant). By substituting  $q_1 = M_1 / R_1 h$ , one obtains

$$H_1 = \frac{M_1 L_{b1}}{R_1 h_{CF}} \quad (10)$$

where  $R_1$  is taken as the radius of curvature of the girder at location 1. The moment in this equation,  $M_1$ , is taken as the value at the cross-frame position, i.e.,  $M_1 = M_1(L_{b1})$ .

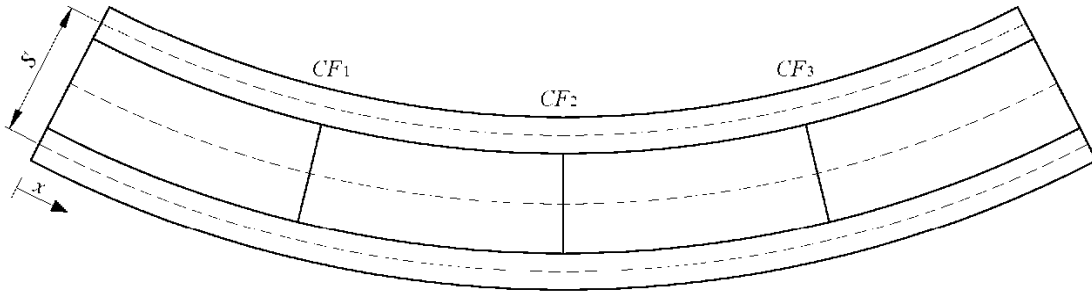
The reaction at the bottom chord level is the same as  $H_1$ , but is in the opposite direction, since the moment causes compression in the top flange and is assumed to cause an equal tension in the bottom flange. Similarly, for the interior girder, G2, the reaction,  $H_2$ , may be written as

$$H_2 = q_2 L_{b2} = \frac{M_2 L_{b2}}{R_2 h_{CF}} \quad (11)$$

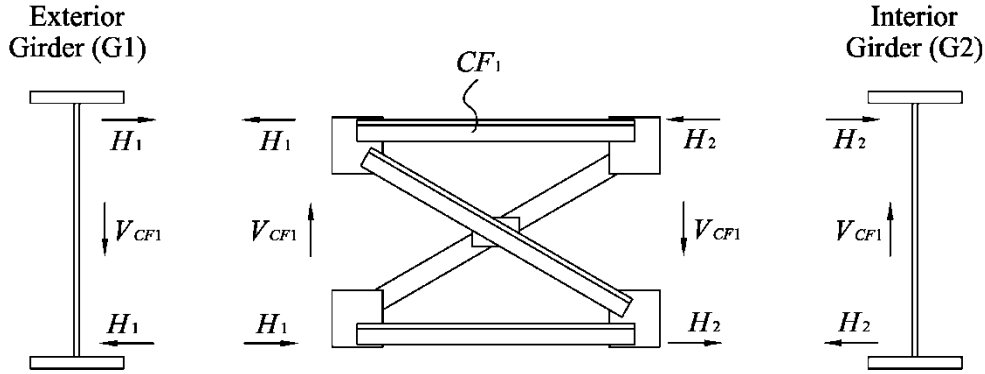
where  $M_2 = M_2(L_{b2})$ . Note that  $L_{b1}/R_1 = L_{b2}/R_2$  may be written as a common value  $L_b/R$ , such that  $H_1 = M_1 L_b/Rh_{CF}$  and  $H_2 = M_2 L_b/Rh_{CF}$ .

In the cross-frame shown in Figure 2.4b, moment equilibrium requires that

$$V_{CF1} = \frac{(H_1 + H_2)h_{CF}}{S} = \frac{M_1 + M_2}{RS/L_b} \quad (12)$$



(a) Plan view of the two-girder system



(b) Free body diagram of the first intermediate cross-frame

**Figure 2.4: Interaction of forces in a curved girder system.**

These vertical forces are a direct effect of the horizontal curvature, and are known as the V-loads. In Eq. 10, the subscript  $CF1$  is used to emphasize that this is a load at the first intermediate cross-frame position. Similarly, the loads at the other cross-frame positions can be found by substituting the corresponding moments  $M_1$  and  $M_2$ , accordingly. In the exterior girder, G1, the additional moments caused by the downward action of the V-loads,  $M_{1s}$ , add to the moments produced directly by the gravity loads,  $M_{1p}$ . In the interior girder, G2, these loads are in opposite directions, so the resulting moments are subtracted from the gravity load moments. Therefore, the total moment in a particular cross-section of girder G1,  $M_1$ , is equal to  $M_{1p} + M_{1s}$ . Likewise, for the interior girder,  $M_2 = M_{2p} + M_{2s}$ . Moreover, at any cross-frame position,  $M_{1s} \cong -M_{2s} (L_1/L_2)$ , where  $L_1$  and  $L_2$  are the arc-span lengths of G1 and G2, respectively. For practical cases, the term  $(L_1/L_2)$  is close to one, so  $M_{1s} \approx -M_{2s}$ . Given this approximation, the sum of the total moments in G1 and G2,  $M_1 + M_2$ , may be taken as  $M_{1p} + M_{2p}$ . Substituting this result into Eq. 10, one has

$$V_{CF1} = \frac{M_{1p} + M_{2p}}{RS/L_b} \quad (13)$$

Given the above approximations, the girders can be analyzed independently using a line-girder analysis. The curved girders are represented with equivalent straight girders of length  $L_1$  and  $L_2$ , and they are subjected to the gravity loads plus the V-loads.

The above development can be extended to consider cases with more than two girders. As explained by Poellot (1987), the V-loads in a multi-girder system are the total vertical loads delivered to the girders from the cross-frames (equal to the difference in the cross-frame shear forces on the interior girders). The V-load delivered to the girder farthest from the bridge centerline is calculated as

$$V = \frac{\sum M_p}{CRS/L_b} \quad (14)$$

The V-loads delivered to the other girders are assumed to vary linearly between a value of zero for any girder at the bridge centerline to the maximum value predicted by Eq. 12 for the girder(s) farthest from the centerline. The constant  $C$  in this equation depends on the number of girders in the structure.

Table 1 shows the values of  $C$  for systems with up to ten girders. These constants are derived based on the above assumption. Section 2.3.2.2.2 of NHI [12] shows a detailed derivation of the coefficient  $C$  in a four I-girder bridge.



**Table 2.1: Values of the C coefficient.**

<b>Girders</b>	<b>Coefficient</b>
2	1
3	1
4	10/9
5	5/4
6	7/5
7	14/9
8	12/7
9	15/8
10	165/81

The V-load idealization basically assumes: (1) approximately equal vertical stiffness of all the girders (defined by a unit load applied at a given cross-frame location, divided by the vertical deflection at that location due to the unit load), and (2) a linear variation in vertical displacements across the bridge cross-section due to overall torsion. In general, the V-load method is reasonably accurate for cases that closely satisfy the above assumptions used in its derivation. However, for bridges with skewed supports, staggered cross-frame patterns, etc., a line-girder analysis based on the V-load method may not be sufficient. For those cases, a 3D FEM analysis model, or 2D-grid model with the recommended improvements discussed subsequently in Section 2.5.5 (which captures the interaction between the structural components more accurately than traditional 2D-grid methods), may be required.

NCHRP report 592 [16] Appendix H describes strengths and limitation of V-load method that are summarized in Table 2.2 here.

**Table 2.2: Strengths and limitation of V-Load method**

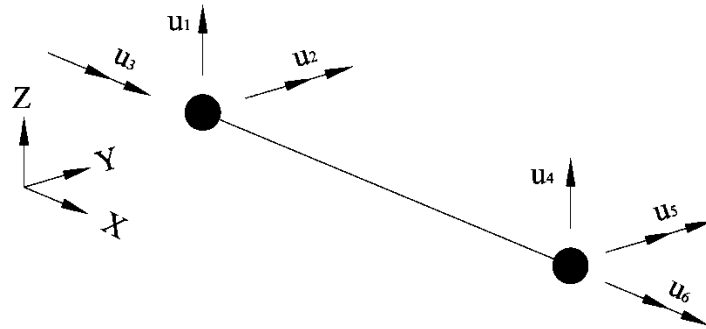
<b>Strengths</b>	<b>Limitations</b>
Method is simple and widely used for the approximate analysis of steel I-girder bridges.	The V-load method does not directly account for sources of torque other than curvature. The method does not account for the horizontal shear stiffness of the concrete deck.
The method is best suited for preliminary design, but may also be suitable for final design of structures with radial supports or	The method is only valid for loads, such as normal highway loadings. For exceptional loadings, a more refined analysis is required.

supports skewed less than approximately 10°.	
	The method assumes a linear distribution of girder shears across the bridge section; thus, the girders at a given cross-section should have approximately the same vertical stiffness.
	The V-load method is also not directly applicable to structures with reverse curvature or to a closed-framed system with horizontal lateral bracing near, or in the plane of one or both flanges.
	The V-load method does not directly account for girder twist; thus, lateral deflections, which become important on bridges with large spans and/or sharp skews and vertical deflections, may be significantly underestimated.
	In certain situations, the V-load method may not detect uplift at end bearings.

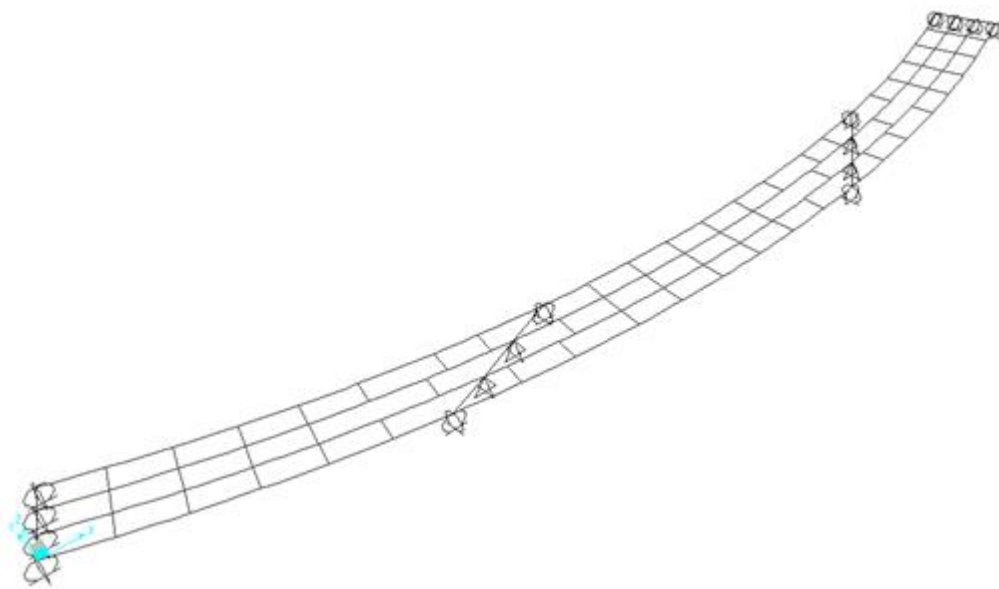
Despite many disadvantages, the V-Load method is still the most popular method nationwide. The Utah DOT conducted a nationwide survey to find the methods of analysis used for curved bridges in different states. Survey results are published in Report No. UT-03.02 [17]. Figure 2.5 shows the map generated from this published data. Out of 36 states that responded to the survey, 21 use the V-Load method, which indicates the popularity of the method.



2.6). The rotational dofs capture the girder major-axis bending and torsional response, and the translational dof corresponds to the vertical displacements. Figure 2.7 shows a perspective view of the curved and skewed continuous-span bridge XICCS7 from NCHRP 725 [6] to illustrate the characteristics of the 2D-grid models.



**Figure 2.6: Schematic representation of the general two-node element implemented in computer programs for 2D-grid analysis of I-girder bridges.**



**Figure 2.7: 2D-grid model of Bridge XICCS7.**

The vertical depth of the superstructure is not considered in 2D-grid models. The girders and their cross-frames or diaphragms are theoretically connected together at a single common elevation, implicitly taken as the centroidal axis of girders (i.e., the axes of all the girders are assumed to bend without any longitudinal or lateral displacement at the connections with the axes of the diaphragms or cross-frames, even if the centroids of the different girders, cross-frames and diaphragms are at different depths). All the girders, diaphragms and cross-frames, all of the loads, and all of the bearings are theoretically located at this same elevation in the model. The analysis calculates only the vertical displacements and the rotations within the plan of the bridge. Many commonly-used commercial software packages such as

DESCUS [18] and MDX [19] utilize these idealizations. In the NCHRP 725 [6] research, MDX as well as the LARSA 4D software [20] were used for the analysis studies conducted using 2D-grid models.

It should be noted that the traditional 2D-grid analyses conducted in the NCHRP 725 research involved the use of the physical girder St. Venant torsion constant,  $J$ , in setting the torsional properties of the girders, as well as the shear stiffness method discussed in AASHTO/NSBA G13.1 [1] for determining the stiffness of the cross-frames.

In 2D analysis techniques, the steel framing of bridge is modeled in a plane. Normally, beam elements are adopted and different geometric properties are averaged on nodes in this technique. Typical strengths and limitations are discussed in Table 2.3.

**Table 2.3: Strengths and limitations of 2D analysis**

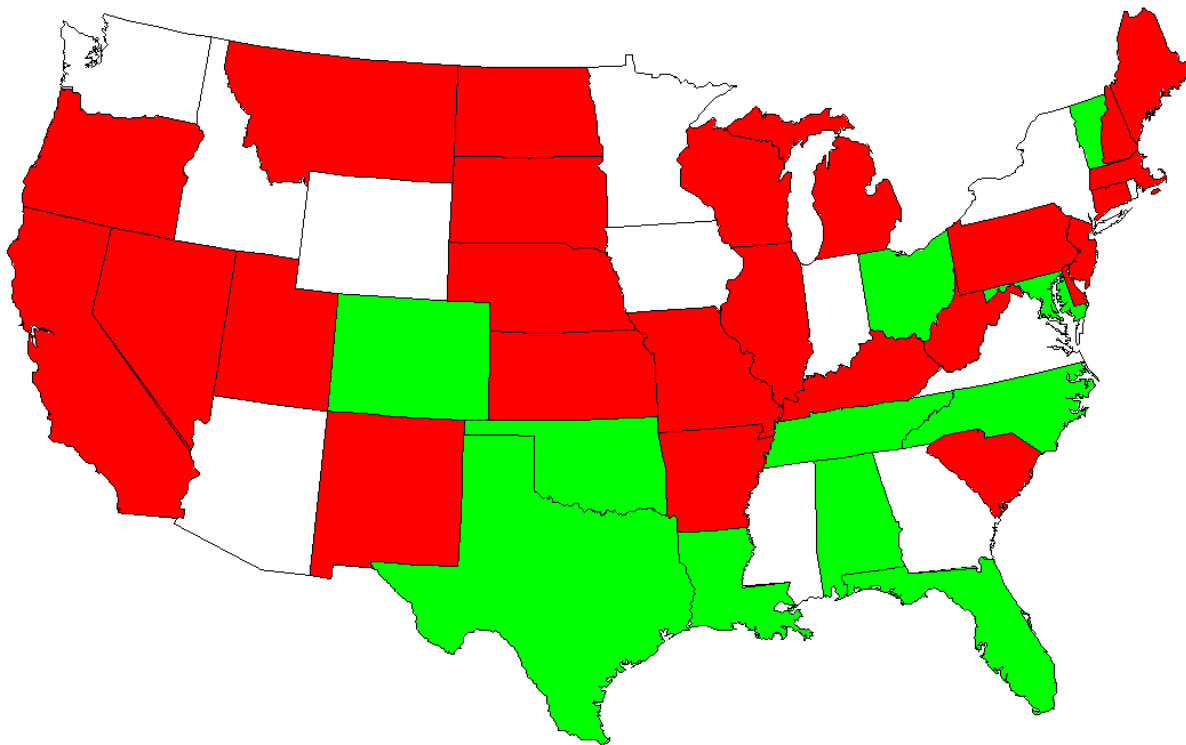
Strengths	Limitations
Relative simple compared to 3D analysis.	Consideration of geometric of members that are in third dimension e.g. cross-frames may get very complicated.
Analysis can be done quickly by using simple commercial software available.	Mechanism of load transfer from one girder to another girder may be oversimplified, especially in case of skewed bridges.
If stiffness matrix is formulated to include warping stiffness of cross-frame, results of 2D analysis are very similar to those of 3D analysis.	Not recommended for complicated geometries or problematic structures.
Can be used for simple/traditional cases for which examples of detailed analysis are already documented.	
Normally, programs based on this approach (for example DESCUS) have built-in live loads and dead loads that make the analysis simple.	

In the DESCUS program, developed at the University of Maryland, the bridge structure is modeled as a two-dimensional grid. Modeling is done in a stiffness format with three degrees of freedom at each

nodal point (corresponding to torsion, shear, and bending moment). It can be used to perform an analysis of a horizontally curved bridge composed of steel box sections. Either the Load Factor Design method or the Load Resistance Factor Design (LRFD) method can be applied in the program.

All Dead Load (DL) computations are performed automatically within the program to satisfy the construction conditions specified by AASHTO. Additional Dead Load and Superimposed Dead Load (SDL) are allowed to be input to combine with the program-generated dead load. All Live Load (LL) computations are also performed automatically where the AASHTO truck and lane loadings are applied to an influence surface previously generated for the entire bridge.

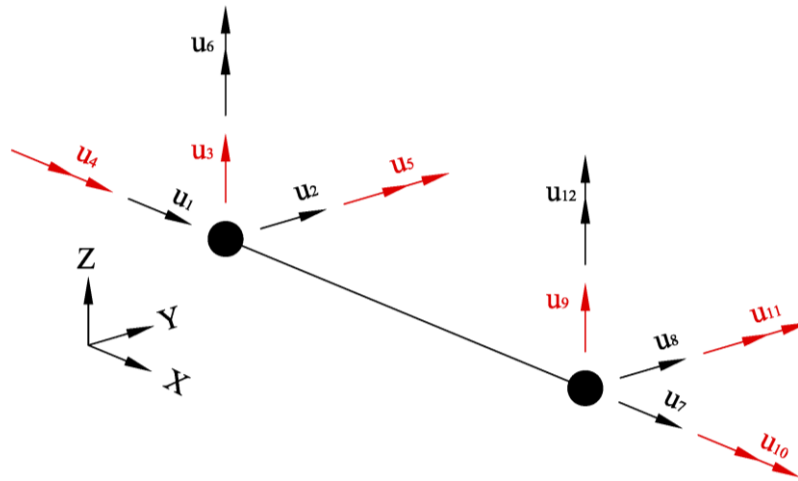
According to the Utah DOT survey results, published in 2003 in Report No. UT-03.02. [17], 11 out of 36 states used DESCUS for analysis, which makes it the second popular method. Figure 2.8 shows the map generated from this published data.



**Figure 2.8: Nationwide use of DESCUS (Green=Method Used, Red=Method Not Used, White=Not participated in Survey or other).**

#### 2.4.4 Traditional 2D-Frame Methods

When using general-purpose software packages, 2D-grid models typically are constructed using beam or frame elements that have six dofs per node. As shown in Figure 2.9, these elements have three translational and three rotational dofs at each node. In this figure, the dofs that are essential to construct a 2D-grid model are  $u_3$ ,  $u_4$ ,  $u_5$ ,  $u_9$ ,  $u_{10}$ , and  $u_{11}$ . These implementations are distinguished from the analysis types discussed in Section 2.5.3 by referring to them as 2D-frame methods.



**Figure 2.9: Schematic representation of the general two-node element implemented in computer programs for 2D frame analysis of I-girder bridges.**

If the structural model is constructed all in one plane, with no depth information being represented, and if the element formulations do not include any coupling between the traditional 2D-grid dofs and the additional dofs (which is practically always the case), 2D-frame models actually do not provide any additional information beyond the ordinary 2D-grid solutions described in Section 4.3. Assuming gravity loading normal to the plane of the structure, all the displacements at the three additional nodal dofs will be zero. Therefore, *for purposes of discussion in this report, 2D-frame models are also referred to as 2D-grid*. Nevertheless, the 2D-grid implementation in LARSA 4D discussed by White et al. (2012) [6] is specifically a 2D-frame model.

#### 2.4.5 Improved 2D-Grid Method

NCHRP 725 [6] identified four specific shortcomings of traditional 2D-grid methods that generally must be rectified to maximize the potential accuracy of 2D-grid analysis methods. The shortcomings are that traditional 2D-grid methods:

- 1) Substantially under-estimate I-girder torsional stiffness,

- 2) Commonly use an equivalent beam representation that substantially misrepresents the cross-frame responses,
- 3) Do not address girder flange lateral bending due to skew, and
- 4) Do not address the calculation of lack-of-fit internal forces due to cross-frame detailing.

The last item is also a shortcoming commonly encountered in more refined 3D finite element design analyses as well.

The research provided improvements in each of these areas that are relatively simple to implement in practice and provide substantial benefits with minimal additional calculation.

Each of the following subsections addresses these individual shortcomings and the recommended improvements.

#### 2.4.5.1 Improved I-Girder Torsion Model for 2D-Grid Analysis

The traditional use of just the St. Venant term ( $GJ/L$ ) in characterizing the torsional stiffness of I-girders results in a dramatic underestimation of the true girder torsional stiffness. This is due to the neglect of the contributions from flange lateral bending, i.e., warping of the flanges, to the torsional properties. Even for intermediate steel erection stages where some of the cross-frames are not yet installed, the typical torsional contribution from the girder warping rigidity ( $EC_w$ ) is substantial compared to the contribution from the St. Venant torsional rigidity ( $GJ$ ). It is somewhat odd that structural engineers commonly would never check the lateral-torsional buckling capacity of a bridge I-girder by neglecting the term  $EC_w$  and using only the term  $GJ$ . Yet, it is common practice in traditional 2D-grid methods to neglect the warping torsion contribution coming from the lateral bending of the flanges.

The NCHRP 725 [6] research observed that an equivalent torsion constant,  $J_{eq}$ , based on equating the stiffness  $GJ_{eq}/L_b$  with the analytical torsional stiffness associated with assuming warping fixity at the intermediate cross-frame locations and warping free conditions at the simply-supported ends of a bridge girder, potentially could result in significant improvements to the accuracy of 2D-grid models for I-girder bridges. This observation was based in part on the prior research developments by Ahmed and Weisgerber [21], as well as the commercial implementation of this type of capability within the software RISA-3D. The term  $L_b$  in the stiffness  $GJ_{eq}/L_b$  is the unbraced length between the cross-frames.

When implementing this approach, a different value of the equivalent torsional constant  $J_{eq}$  must be calculated for each unbraced length having a different  $L_b$  or any difference in the girder cross-sectional properties. Furthermore, it is important to recognize that the use of a length less than  $L_b$  typically will



result in a substantial over-estimation of the torsional stiffness. Therefore, when a given unbraced length is modeled using multiple elements, it is essential that the unbraced length  $L_b$  be used in the equations for  $J_{eq}$ , not the individual element lengths.

By equating  $GJ_{eq}/L_b$  to the torsional stiffness ( $T/\phi$ ) for the open-section thin-walled beam associated with warping fixity at each end of a given unbraced length  $L_b$ , where  $T$  is the applied end torque and  $\phi$  is corresponding relative end rotation, the equivalent torsion constant is obtained as

$$J_{eq(fx-fx)} = J \left[ 1 - \frac{\sinh(\rho L_b)}{\rho L_b} + \frac{[\cosh(\rho L_b) - 1]^2}{\rho L_b \sinh(\rho L_b)} \right]^{-1} \quad (15a)$$

where

$$\rho = \sqrt{\frac{GJ}{EC_x}} \quad (15b)$$

Similarly, by equating  $GJ_{eq}/L_b$  to the torsional stiffness ( $T/\phi$ ) for the open-section thin-walled beam associated with warping fixity at one end and warping free boundary conditions at the opposite end of a given unbraced length, one obtains

$$J_{eq(s-fx)} = J \left[ 1 - \frac{\sinh(\rho L_b)}{\rho L_b \cosh(\rho L_b)} \right]^{-1} \quad (15c)$$

The assumption of warping fixity at all of the intermediate cross-frame locations is certainly a gross approximation. TWOS 3D-frame analysis (see Section 2.7.3 for a description of this terminology) generally shows that some flange warping (i.e., cross-bending) rotations occur at the cross-frame locations. However, the assumption of warping fixity at the intermediate cross-frame locations leads to a reasonably accurate characterization of the girder torsional stiffnesses pertaining to the overall deformations of a bridge unit as long as:

- There are at least two I-girders connected together, and

- They are connected by enough cross-frames such that the connectivity index  $I_C$  is less than 20 ( $I_C \leq 20$ ).

where  $I_C$  is the connectivity index, defined as

$$I_C = \frac{15000}{R(n_{cf} + 1)m} \tag{16}$$

where  $R$  is the minimum radius of curvature at the centerline of the bridge cross-section in ft. throughout the length of the bridge,  $n_{cf}$  is the number of intermediate cross-frames in the span, and  $m$  is a constant taken equal to 1 for simple-span bridges and 2 for continuous-span bridges. In bridges with multiple spans,  $I_C$  is taken as the largest value obtained from any of the spans.

The NCHRP 725 [6] reports provide extensive documentation and demonstration of the analysis accuracy achieved by the above improvement.

#### 2.4.5.2 Improved Equivalent Beam Cross-Frame Models

Two of the most commonly used methods for determining the stiffness of equivalent beam elements representing the cross-frames are termed by AASHTO/NSBA as the flexural stiffness and shear stiffness methods. The flexural stiffness method basically equates the flexural stiffness of an Euler-Bernoulli beam element,  $4EI/L$ , to the  $M/\theta$  determined by supporting the cross-frame as a propped cantilever and subjecting it to the couple  $M$  at its simply-supported end. The resulting equation is solved for the moment of inertia  $I$  of the equivalent beam. The shear stiffness method equates the shear racking stiffness of a fixed-fixed Euler-Bernoulli beam,  $12EI/L^3$ , to the corresponding  $V/\Delta$  of the cross-frame when it is prevented from rotation at both of its ends and subjected to the transverse shear force  $V$ . Again, the resulting equation is solved for the equivalent moment of inertia of the Euler-Bernoulli beam. The MDX software system [19] provides the former of these calculations as its default cross-frame representation, but allows the user to specify the latter calculation if desired.

Both of these options can substantially mis-represent the actual cross-frame stiffness characteristics. White et al. [6] show that, whereas the Euler-Bernoulli beam element always has a carry-over factor of 0.5, meaning that the moment at the fixed end of a propped cantilever is oriented in the same global

direction and is one-half of the applied moment at the simply-supported end, the corresponding moment at the fixed end of a cross-frame with these same overall boundary conditions can easily be in the opposite global direction. This is due to the substantial shear flexibility of cross-frames, since the dominant behavior of cross-frames is their behavior as a truss. White et al. [6] also show that the correct cross-frame flexural rigidity typically can be substantially larger than that obtained using either the above flexural or shear stiffness methods. This is because the true flexural stiffness of the cross-frame is the stiffness corresponding to pure bending with zero shear.

The NCHRP 725 [6] research recommends the simplified use of a Timoshenko beam element for the modeling of cross-frames and diaphragms and specifies a procedure for determining the flexural rigidity  $EI$  and the beam-shear rigidity  $GA_s$  of this model. The Timoshenko beam element generally is still only an approximation of the true cross-frame stiffness characteristics unless the cross-frame is an X-type with equal top and bottom chords. However, the Timoshenko beam element provides good accuracy for essentially all types of cross-frames with the exception of K-type cross-frames without top chords. Alternative “exact” equivalent beam formulations also are developed in the NCHRP 725 research, but are more involved in their implementation. The Timoshenko beam element is a natural fit to the modeling of diaphragms.

In addition to the above NCHRP 725 developments, research at the University of Texas, Austin [4] has recently been completed providing a detailed investigation of the impact of bending of cross-frame single-angle members due to the connection eccentricities at their ends on cross-frame stiffnesses. Calibration factors are provided for various specific cases, but as a general rule, the single-angle cross-frame member axial stiffnesses are reduced by approximately 50 % due to the eccentric bending of these members under axial load.

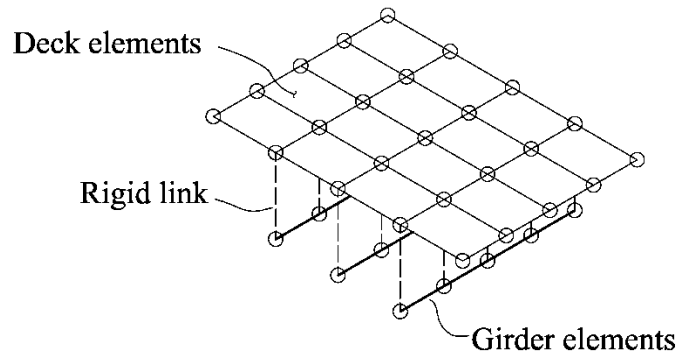
In many I-girder bridge structural systems, the cross-frames and/or diaphragms are relatively rigid compared to the I-girders due to the relatively large I-girder span lengths compared to the girder spacing and the bridge width. In these cases, all of the above stiffness models produce essentially the same results. However, in I-girder structural systems that have substantial transverse load paths associated with a large skew index (e.g.,  $I_S > 0.30$  in Eq. 6), the increased accuracy associated with the above improvements is needed.

### 2.4.5.3 Direct Calculation of Flange Lateral Bending due to Skew Effects

Given the above improvements in the modeling of the I-girder torsional stiffnesses and the cross-frame equivalent beam stiffnesses, the NCHRP 725 research [6] shows that grid analysis models are able to provide a close estimate of the results from more refined 3D FEA solutions for the overall bridge responses, including the diaphragm and cross-frame forces. Given an accurate calculation of the cross-frame and diaphragm forces, the engineer may then determine statically equivalent flange lateral loads from these members as well from the effects of horizontal curvature, eccentric loads on slab overhangs, etc. Given these statically equivalent lateral loads, one can determine an accurate estimate of the I-girder flange lateral bending stresses. The reader is referred to [6] for a detailed discussion of the processes.

### 2.4.6 Plate and Eccentric Beam Models

The MDX Software system implements a second type of model for the analysis of I- and tub-girder bridges that is commonly referred to as a plate and eccentric beam model. In this idealization, the composite bridge deck is modeled using flat shell (or plate) finite elements and the girders are modeled using 6 dof per node frame elements (total of 12 dofs per element, see Figure 2.9) with an offset relative to the slab (see Figure 2.10).



**Figure 2.10: Schematic representation of the plate-and-eccentric-beam model.**

The plate and eccentric beam (PEB) model is used typically for analysis of composite bridge structures in their final constructed configuration. In the NCHRP 725 [6] research, this type of modeling approach was used in the design of various parametric study bridges. Specifically, it was used for the design analysis of the bridges in their final constructed condition.

It should be noted that the PEB approach generally does not account for the distortional flexibility of the composite I-girders, i.e., the tendency of the I-girder webs to distort into an S shape under the action of torsional loads. In some cases, this can lead to a noticeable over-estimation of the torsional stiffness in the composite bridge system (Chang and White, 2008) [22]. The rigid link between the deck elements and the steel girders effectively models the steel portion of the composite I-girders assuming that their I-section profile is unchanged throughout the analysis. Chang and White (2008) [22] evaluate various simplified approximations and discuss a number of adjustments that can be made to refined models that otherwise accurately capture the I-section torsional stiffness.

#### **2.4.7 Traditional 3D-Frame Methods**

An analysis model may be referred to as a traditional 3D-frame if:

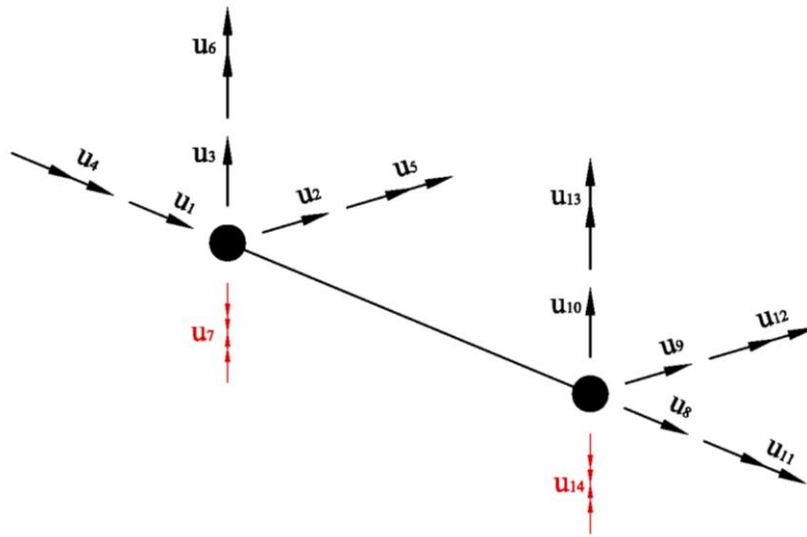
- The structure is modeled using the above 3D frame elements and the centroid and shear center of the girders are modeled at their actual spatial locations,
- The actual location of the cross-frames or diaphragms through the depth is modeled (typically using a single frame element to represent each entire cross-frame or diaphragm between the points of connection to the other components)
- Rigid offsets are used to represent the differences in the depths between the girders, the cross-frames, and the bridge bearings.

It is important to note that this type of model generally provides little to no additional accuracy in representing the bridge responses for I-girder bridges, unless accurate girder torsional stiffnesses and accurate cross-frame generalized stiffnesses are employed. This is because the typical torsional stiffness used by the elements shown in Figure 2.9 is simply  $GJ/L$ . However, it is well known that the physical I-girder stiffnesses are dominated by the nonuniform torsion associated with warping of the cross-section (i.e., lateral bending of the flanges). In most situations with I-girder bridges, the St. Venant torsional stiffness  $GJ/L$  is so small, compared to the physical torsional stiffness, any results influenced by torsion have essentially no resemblance to the true physical responses if only the St. Venant torsional response is included. Adjustments recommended by the NCHRP 725 research to rectify this problem are discussed in Section 2.5.5.

#### **2.4.8 Thin-Walled Open-Section (TWOS) 3D-Frame Methods**

The most accurate frame (i.e., line) element model for I-girder bridges is designated here as a Thin-Walled Open-Section (TWOS) 3D-frame model. This name is used to refer to bridge models constructed

with a frame element having seven dofs per node, three translations, three rotations and one warping dof. A schematic representation of a line element having these characteristics is shown in Figure 2.11. The warping degrees of freedom are numbered 7 and 14 in the sketch. This type of element can be utilized to provide a highly accurate characterization of bridge I-girder torsional responses. Typically, this type of element has been used along with comprehensive modeling of the depth information throughout the structure, i.e., representation of the girder shear center and centroidal axes, modeling of the cross-frames, and representation of bearings all at their corresponding depths. Selected studies were conducted in the NCHRP 725 [6] research using this type of element as implemented by Chang [23] in the program GT-Sabre. GT-Sabre not only includes a refined open-section thin-walled beam theory representation of the I-girders, but it also includes the modeling of all the individual cross-frame components (i.e., the separate modeling of the cross-frame chords and diagonals using individual frame elements). In GT-Sabre, the individual elements representing the cross-frame members are tied to the girder nodes by rigid offsets.



**Figure 2.11: Schematic representation of a general two-node 3D TWOS frame element implemented in computer programs of I-girder bridges.**

The TWOS 3D-frame modeling approach is capable of matching the results of 3D FEA quite closely, with the exception that it is not able to capture the influence of I-girder web distortion on the physical responses. Web distortion can be an important factor when modeling composite I-girder torsional responses [23] [22], but otherwise, its effect is typically inconsequential. In basic terms, if a TWOS element is tied to a slab via a rigid link, similar to the plate and eccentric beam modeling approach, the slab will incorrectly restrain the lateral bending of the bottom flange unless special modeling procedures, such as those discussed by Chang [23], are invoked.

As discussed by Chang [23], there are a number of other complexities that are difficult to handle in the implementation of 3D TWOS frame elements. These include the modeling of continuity conditions at cross-section transitions (e.g., changes in flange thickness and/or width), and the modeling of the continuity conditions for bifurcated girders (three girder elements framing into a common node). In addition, GT-Sabre [23] is the only known software that correctly displays the detailed three-dimensional deformed geometry from a TWOS 3D-frame analysis. Most TWOS 3D-frame elements have been implemented only in a structural engineering research setting, and either do not include any capability for graphical display of the deflected geometry at all, or display the deformed geometry only as the deformed centroidal axis of the member. Although advanced simulation software systems such as ABAQUS [24], typically can graphically render the 3D I-section geometry, they do not graphically display the detailed warping deformations of 3D TWOS frame elements when they render the displaced geometry of the structure. As a result of the above complexities, as well as the fact that with increasing computer speeds, large degree of freedom 3D FEA computations can be conducted in a small amount of time, 3D FEA generally is preferred over TWOS 3D-frame analysis for design of steel girder bridges when line-girder or 2D-grid methods do not suffice.

### 2.4.9 3D Finite Element Analysis (FEA) Methods

Generally speaking, any matrix analysis software where the structure is modeled in three dimensions may be referred to as a three-dimensional finite element analysis (3D FEA). This report adopts the more restrictive definition of 3D FEA stated by AASHTO/NSBA G13.1 [1]. According to G13.1, an analysis method is classified as a 3D FEA if:

- 1) The superstructure is modeled fully in three dimensions,
- 2) The individual girder flanges are modeled using beam, shell or solid type elements,
- 3) The girder webs are modeled using shell or solid type elements,
- 4) The cross-frames or diaphragms are modeled using truss, beam, shell or solid type elements as appropriate, and
- 5) The concrete deck is modeled using shell or solid elements (when considering the response of the composite structure).

It is important to recognize that the finite element method generally entails the use of a large number “elements” that are small in dimension compared to the structural dimensions that influence the responses to be evaluated. Furthermore, there are many detailed decisions that either explicitly or implicitly can impact the results, and therefore it is important to recognize that not all 3D FEA models are the same. When creating a 3D FEA model, the engineer (explicitly, or implicitly) selects a theoretical representation for the various parts of the structure (e.g., 3D solid, thick shell, thin shell, Timoshenko beam, Euler-Bernoulli beam, etc.), a mesh density sufficient to ensure convergence of the FEA numerical approximations within an acceptable tolerance, an element formulation type such as a displacement-based, flexibility-based or mixed formulation, an interpolation order for the different element response quantities (e.g., linear or quadratic order interpolation of the element internal displacements), a numerical integration scheme for evaluation of the element nodal forces and stiffnesses (e.g., standard Gauss quadrature, Gauss-Lobatto integration, etc.), and procedures for calculating, extrapolating, and smoothing or averaging of element internal stresses and strains.

The handling of the above attributes, as well as various other important analytical and numerical considerations, is beyond the scope of this document. However, with the exception of the first two of the five considerations outlined above, these decisions are more within the realm of finite element software development rather than the domain of engineering design and analysis. The engineer generally should understand the broad aspects of the assumptions and limitations of the 3D FEA procedures, to ensure their proper application. Furthermore, generally he or she should conduct testing and validation studies



with the software to ensure that the methods work as intended and that they provide correct answers for relevant benchmark problems.

Basically, the objective of 3D FEA models targeted for design analysis is the accurate calculation of all the bridge responses utilized by the AASHTO LRFD Specifications for the *overall* design of the structure. Different analysis objectives, although they may be applied to the same structure, generally require different finite element models. For example, 3D FEA can be very useful for performing refined local stress analysis of complex structural details. This is not the typical objective of a 3D FE design analysis. A 3D FE design analysis typically aims to calculate accurate:

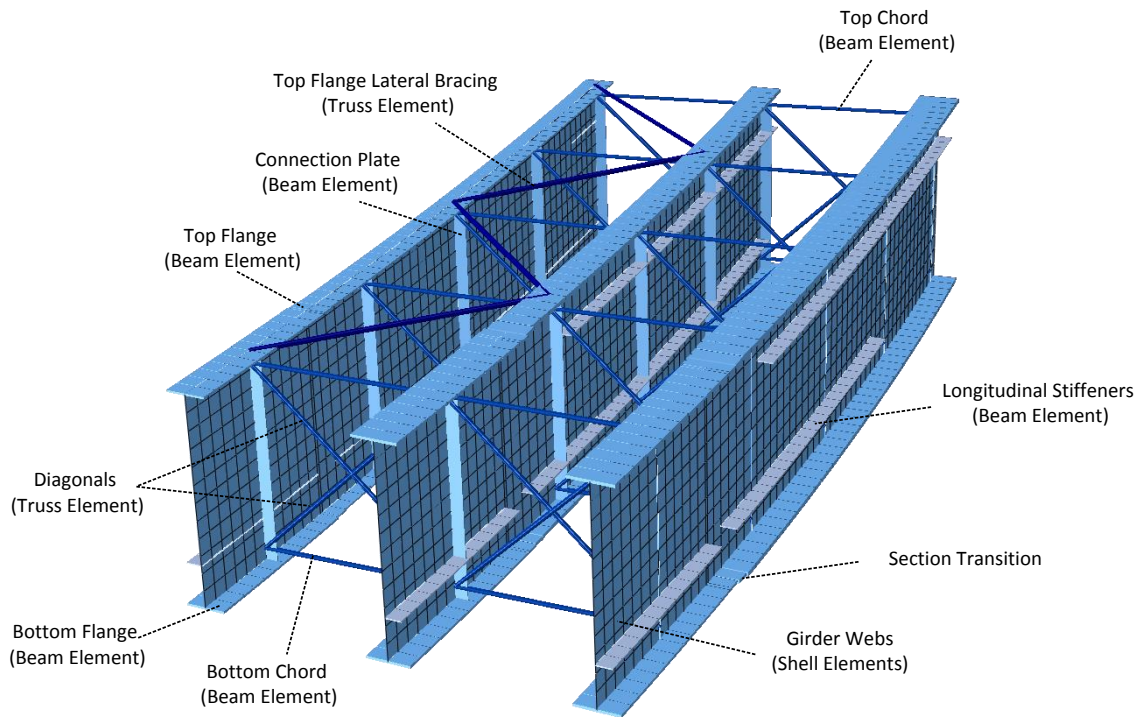
- Elastic girder vertical deflections, lateral deflections, and rotations,
- Elastic girder major-axis bending stresses, or the corresponding bending moments, flange lateral bending stresses, web shear forces, and for tub girders, bottom flange shear stresses,
- Elastic cross-frame component axial forces,
- Elastic diaphragm major-axis bending stresses and web shear stresses, or the corresponding bending moments, and web shear forces, and
- Where composite action is considered, elastic slab normal and shear stresses and strains.

There are various 3D FEA modeling strategies that can accomplish these objectives. Figure 2.12 shows a representative segment of a three I-girder bridge unit illustrating typical 3D finite element representations of the various structural steel components. All of the bridge components are modeled at their physical geometric locations using the nominal dimensions, with the exception that the girder webs are modeled between the centerlines of the girder flanges. Therefore, the flanges are at the correct physical depth in all cases, and the model of the web has an overlap of  $t_f/2$  with the flange areas. This is comparable to the manner in which joint size often is neglected in the modeling of frame structures; the resulting additional web area is on the order of the steel area from web-flange fillet welds, while the web-flange fillet welds are not explicitly included in the model.

Various decisions in addition to the direct modeling of the components that generally are required for design analysis of I-girder bridges. These include, but are not limited to

- Coarse modeling of specific sources of flexibility such as particular connection deformations, and additional flexibility of cross-frame members due to bending under eccentric axial loads.
- Modeling of the influence of bearing constraints such as guided and fixed bearings and their influence on the 3D response under vertical load, particularly for curved I-girder systems.

- Modeling of specific sources of additional stiffness such as restraint of anticipated movements at bearings.



**Figure 2.12: Example of recommended 3D FEA modeling approach on a segment of a three-I-girder bridge unit.**

- Modeling of substructure deformations and their influence on the superstructure response, particularly for systems with tall piers, and/or with substructure components such as straddle bents, which may result in significant differential support movements and interaction between the substructure and superstructure response.
- Potential uplift at bearings.
- Geometric nonlinear (stability) effects.
- For bridges involving staged deck placement, early stiffness gains of the concrete deck slab from prior stages.

The AASHTO/NSBA G13.1 document [1] provides a wide range of recommendations on handling of these and other structural characteristics.

3D analysis is normally carried out for complicated framing geometries, signature projects, or investigation of problematic bridges. Table 2.4 provides some strengths and limitations of 3D FEM analysis.

**Table 2.4: Strengths and limitations of 3D FEM analysis**

<b>Strengths</b>	<b>Limitations</b>
Unlike 2D analysis, framing component in third dimension can be modeled with more appropriate geometric properties and locations.	Compared to 2D analysis, more time and skill is required to carry out 3D analysis
It is useful for the bridges with complicated super-structure.	It may increase the cost of the project.

## 2.5 Summary

This chapter provides a detailed list of cross-frame functions and sources of cross-frame forces in steel bridges. Different methods that are currently used for calculating cross-frame forces and flange lateral bending stresses are described. The chapter also provides strengths, limitations and modeling difficulties associated with each method of analysis. These methods are generally used for the straight non-skewed bridges or bridges detailed with no-load fit detailing method.

Cross-frames practically fit between their connections to girder at all loading stages of construction for the straight bridges without skew or skew less than 20 degrees. Therefore, method of detailing cross-frames does not influence the method of analysis or the level of analysis required for calculating the cross-frame forces or other structural responses. This is not true for the straight skewed bridges with skew greater than 20 degrees and level of analysis is required is dependent on detailing method. In the next chapter, a discussion of the different detailing methods that can be used for straight skewed bridges is provided along with recommendations of simplified methods of analysis for calculating the cross-frame forces.

### **3 Simplified Methods of Analysis for Different Detailing Methods**

The girder webs in straight skewed bridges can be detailed to be plumb at one of the different construction loading stages. As noted earlier, there are generally three stages that are used to reference when the girder webs are plumb: 1) the No-load (NL) stage, 2) the Steel dead load (SDL) stage, or 3) the Total Dead Load (TDL) stage [25]. The term consistent detailing is often used to describe the case in which both the girders and the cross-frames are detailed for the webs to be plumb at the same stage. The girders are often fabricated to be plumb at the NL stage; however, cross-frames can be fabricated for web plumb at either NL or SDL or TDL stage. The term inconsistent detailing is typically used to describe the situation where the girder webs are detailed to be plumb in one stage (usually the NL stage) and the cross-frames are detailed for the web to be plumb at a different stage (i.e. the SDL or TDL stages). Another set of terminologies, No-load Fit (NLF), Steel dead load Fit (SDLF), and Total Dead Load (TDLF), is also used to describe above three scenarios. When the NLF method is employed, the cross-frames are fabricated for the web to be plumb at the NL stage. As the name implies, both the girder and cross-frame are detailed to fit when the girder rests on the ground, blocked-up in its fabricated NL geometry including any vertical curve and camber in the girders. However, once dead load is applied the girder experiences twist due to bearing line rotation and differential deflection occurs as explained earlier. When the SDLF method is employed, the cross-frames are fabricated for the web to be plumb at the SDL stage. In this scenario, both the girders and cross-frames are detailed to fit when the girders are erected and supported at the bearing lines (SDL stage). Similarly when the TDLF method is employed, the cross-frames are fabricated for the web to be plumb at the TDL stage. In this scenario, both the girders and cross-frames are detailed to fit when the girders are supported at the bearing lines under total construction dead load.

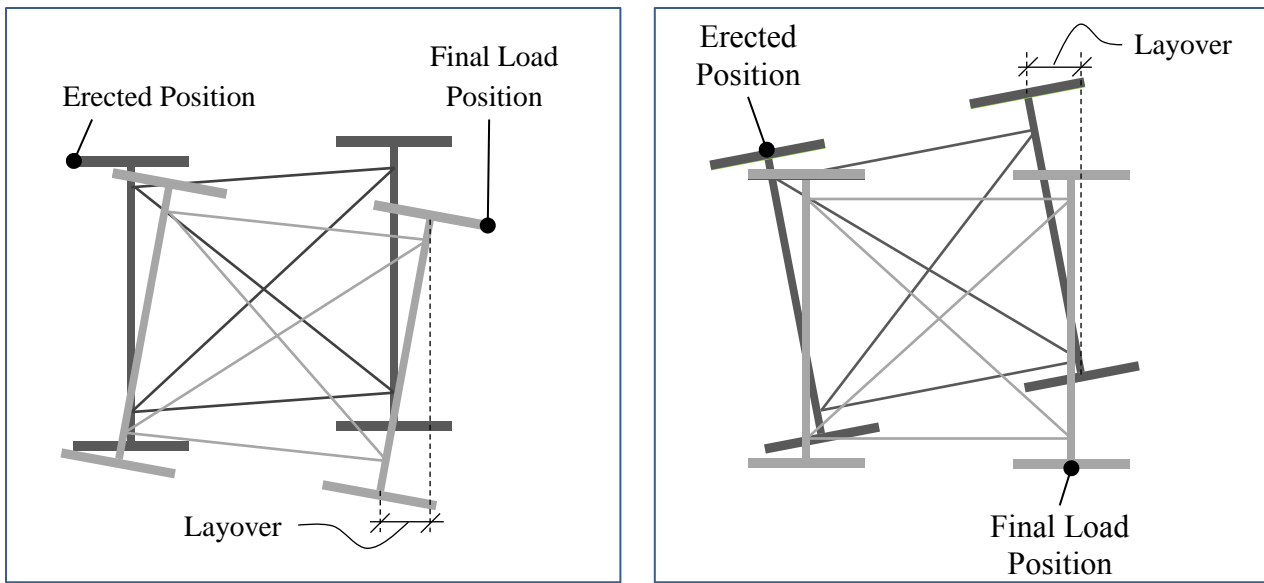
The cross-frames will generally be the easiest to install in the SDLF case as the cross-frames are typically installed as the girders are erected and the girders will have ideally deflected to the SDL condition, which matches the detail condition of the cross-frames. If the NLF scenario is used, significant force may be necessary to fit the girders and cross-frames when the construction is unshored or partially shored. If the TDLF scenario is used, significant force may be necessary to fit the girders and cross-frames, since at the time of the steel erection, the girders have not yet been deflected by the dead load from the concrete deck. As an example, consider the TDLF case in which the girders and cross-frames have been detailed for web plumbness under full construction dead load. Since the girder webs will not be plumb during steel erection, the girders will need to be twisted to install the cross-

frames. The amount of force necessary to fit the cross-frames is highly dependent on the bridge geometry. The force required to twist the girders to have web out of plumb is henceforth referred as the fit-up force.

The terms NLF, SDLF, and TDLF are generally idealized stages that may not actually occur in common practice. For example, in typical steel bridge fabrication, using bolted field splices, the girders are fabricated for the NLF (i.e. laydown). During erection, holding cranes or temporary supports may be necessary to fit-up of the main girder. Therefore, this stage is usually somewhere between the NL stage and SDL stage at the start of erection and gets close to SDL stage near the completion of erection. As a result, the development of simplified terminologies that are consistent with the erection practices is desirable.

To reduce miscommunication, in this chapter the detailing terminologies erected fit (EF) and final fit (FF) are introduced in lieu of NLF, SDLF, TDLF, consistent detailing, and inconsistent detailing.

In the erected fit detailing method, the cross-frames are detailed to fit between the girders at erection or the SDL stage as shown in Figure 3.1 (a). The deformations are not to scale and have been emphasized to demonstrate the positions of the components. The cross-frames do not fit between the girders after the deck is cast or the TDL stage as shown in Figure 3.1 (a). In the final fit detailing method, the cross-frames are detailed to fit between the girders after deck is casted or TDL stage as shown in Figure 3.1 (b). These cross-frames do not fit between the girders at erection or SDL stage as shown in Figure 3.1 (b).



(a) Erected fit detailing method

(b) Final fit detailing method

**Figure 3.1: Erected fit and final fit detailing methods**

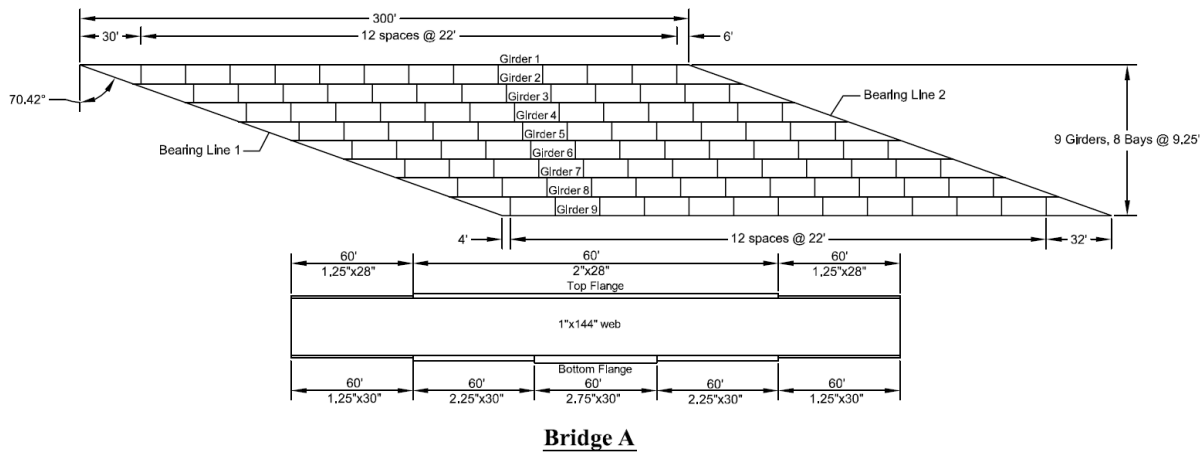
If the final fit detailing method is used for detailing the cross-frames, there is a lack-of-fit between the cross-frames and their connections to the girder at the NL and SDL stages. NCHRP 725 [6] proposed using 3D FEM analyses to simulate this lack-of-fit. The lack-of-fit is modeled into the 3D FEM analyses using initial strains in NCHRP 725 [6]. As discussed earlier, carrying out a 3D FEM analysis can be a relatively complex and a time-consuming task and calculation of initial strain for every single cross-frame makes it even more difficult and a time-consuming. Keeping in mind that the objective of this project is to develop practical guidelines, it is important to have simplified methods of analysis to estimate different responses of skewed bridges detailed with dead load detailing methods.

Therefore, the objective of this chapter is to introduce simplified methods that can be used to calculate different structural responses for erected fit detailing methods at TDL stage and final fit detailing method at SDL stage. A comparison of different methods is done to recommend a single simplified method of analysis that can be used to calculate structural responses for both erected fit and final fit detailing methods with a reasonable accuracy. The following section describes the three bridges that were comparisons of the structural response evaluated from the different methods of analysis for erected fit and final fit detailing methods.

### 3.1 Description of Structures Used for Comparison of Methods Analysis

Three straight skewed, simply supported I-girder bridges having different levels of skew, were selected for consideration in this study. The girders and cross-frames for all three bridges were designed with Grade 50 steel having a modulus of elasticity of 29,000 ksi.

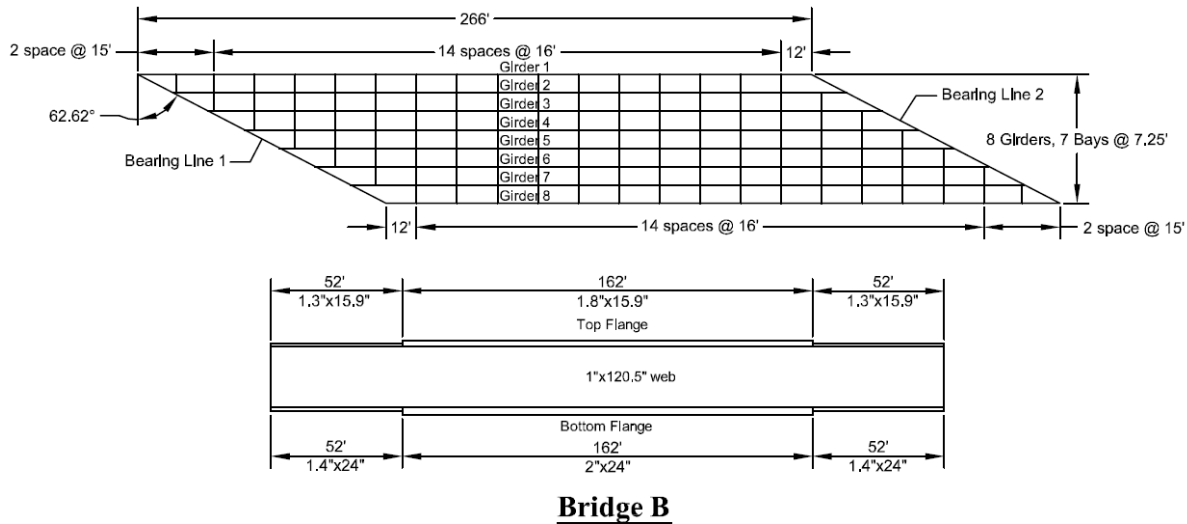
Bridge A is an extreme case of straight skew bridges and was used to show extreme skew effects in previous studies [26] [27] [6]. Bridge A has 300 ft long girders that are 144 in. deep with simple supports and a skew angle of  $70.4^\circ$ . The girders of Bridge A are braced with X-type cross-frames containing L6 x 6 x 1 angles. The bridge uses staggered cross-frames at spacing of 22 ft between 9 girders that have a 9.25 ft c/c spacing. The framing plan and sizes of the web and flanges of Bridge A are shown in Figure 3.2.



**Bridge A**

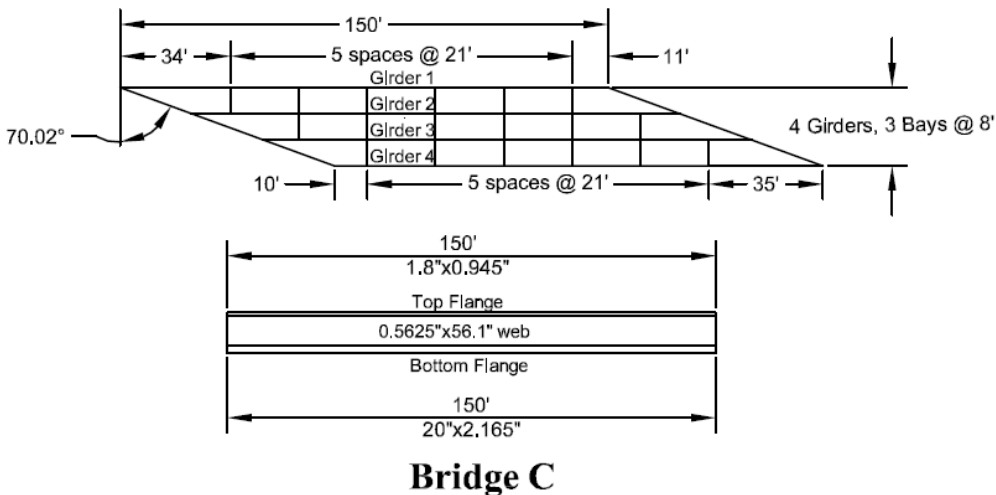
**Figure 3.2. Framing plan and girder sizes of the Bridge A.**

Bridge B is another highly skewed bridge, however the skewed effects in Bridge B are smaller compared to Bridge A. Bridge B has 266 ft long girders that are 120.5 in. deep. The bridge has simple supports with a  $62.6^\circ$  skew angle. The girders of Bridge B are braced with X-type cross-frames containing L6 x 6 x 1/2 angles. The bridge uses cross-frames at a spacing of 16 ft between the eight girders that have a c/c spacing of 7.26 ft. The framing plan and sizes of the web and flanges of Bridge B are shown in Figure 3.3.



**Figure 3.3. Framing plan and girder sizes of the Bridge B.**

Bridge C consisted of 150 ft long girders with a depth of 56.1 in. The bridge had simple supports with a skew angle of 70.0°. The girders of Bridge C are braced with X-type cross-frames containing L6 x 3 1/2 x 5/16 angles. The bridge uses cross-frames at spacing of 21 ft between that four girders that were spaced 8 ft c/c. The framing plan and sizes of the web and flanges of the bridges studied are shown in Figure 3.4.



**Figure 3.4. Framing plan and girder sizes of the Bridge C.**



## 3.2 Erected Fit Detailing Method

It is important to distinguish between the procedures used for the evaluation in the structural response of the bridge detailed with erected fit detailing method from the procedures used in NCRHP 725 [6]. NCRHP 725 [6] used only 3D FEM analyses to calculate the structural responses of the bridge detailed with the erected fit detailing method. These 3D FEM models represent the initial lack-of-fit between the cross-frames and the girders at the NL stage using initial strains. The approach used in the current study did not utilize initial strains for the evaluation on the structural responses for erected fit detailing method. Instead, all the structural responses corresponding to SDL were estimated from a line girder analysis, assuming the girders were placed on the supports without attaching cross-frames. However, the structural responses corresponding to concrete dead load were calculated by 2D-grid analysis or 3D FEM analyses modeling the cross-frames and girder connected together. Sections 3.2.1 and 3.3.2 describe the methods of calculating the structural responses for erected fit detailing method corresponding to concrete dead load only.

### 3.2.1 Methods of Analysis

Before discussing the structural responses of skewed steel girder bridges, it is important to discuss different methods of analysis that were used in the study. Although, these methods of analysis are discussed at length in NCHRP 725 [6] and Chapter 2 of this report, a brief summary is also provided in this chapter.

#### 3.2.1.1 2D-grid Analysis

In the discussion, a 2D-grid analysis (GA) refers to a modeling technique in which each node has six degrees of freedom (3 translations and 3 rotations), but the entire structural model of the bridge is in a single horizontal plane. Two types of 2D GA were considered in the study: 1) simplified methods that are used by some commercial programs, hereafter referred at as a traditional 2D GA, and 2) an improved 2D GA as recommended in NCHRP 725 [6].

In the traditional 2D GA, the torsional stiffness of the girders is estimated by the St. Venant term using the torsional constant ( $J$ ) as calculated for the I-shaped girder. In the improved 2D GA, the torsional stiffness of the girder is modeled by using an equivalent torsional constant ( $J_{eq}$ ) that takes into account both the St. Venant and warping terms in the calculation of the torsional stiffness. A detailed expression for obtaining  $J_{eq}$  for I-sections is given in the literature [21] and presented below in Eqs. 17 and 18.

Eq. 17 is based upon the assumption that both ends of the unbraced length,  $L_b$ , are fixed, while Eq. 18 is based upon the assumption that one end of the unbraced length is fixed and the other is pinned.

$$J_{eq(fx-fx)} = J \left[ 1 - \frac{\sinh(pL_b)}{pL_b} + \frac{[\cosh(pL_b) - 1]^2}{pL_b \sinh(pL_b)} \right]^{-1} \quad (17)$$

$$J_{eq(fx-fx)} = J \left[ 1 - \frac{\sinh(pL_b)}{pL_b \cosh(pL_b)} \right]^{-1} \quad (18)$$

Where

$$p = \sqrt{\frac{GJ}{EC_w}}$$

$G$  is the modulus of rigidity and can be approximated by  $G = \frac{E}{2(1+\nu)}$ ,  $E$  is modulus of elasticity,  $\nu$  is Poisson's ratio (0.3 for metals), and  $C_w$  is the warping constant.

Cross-frames were modeled using a beam element with a moment of inertia ( $I_{eq}$ ) that matches the flexural stiffness of the truss representation of the cross-frame. The beam also had a cross-sectional area ( $A_{eq}$ ) that matched the axial stiffness of the cross-frame system. The traditional 2D GA used the Euler Bernoulli beam stiffness matrix; whereas the improved 2D GA employed in the study used an equivalent beam stiffness that matched the in-plane stiffness of a truss idealization of the cross-frames. Detailed derivations and expressions for the stiffness matrices are provided elsewhere [26].

It should be noted that in the erected fit detailing method, the lack-of-fit effects such as layovers, component of deflection due to lack-of-fit, cross-frame forces, component of reactions due to lack-of-fit, and flange lateral bending stress due to skew effects are of interest after placement of the wet concrete.

Therefore, in order to carry out an erected fit analysis using the 2D GA method, a complete model of the structure is constructed with cross-frames attached to the girders followed by activating the concrete dead load.

### *3.2.1.2 3D Finite Element Analysis*

At the research stage, numerous three-dimensional modeling was carried out using ANSYS [28]. Three-dimensional finite element analysis (3D FEM) can be used with different levels of modeling techniques. For example, in a 3D FEM, the flanges can be modeled using either beam elements or shell elements and the model may or may not reflect the effect of bearing pads. 3D FEM analyses carried out as a part of NCHRP 725 modeled the flanges using beam elements and did not consider the impact of the bearing pads. In this study, flanges were modeled using shell elements and also considered in the impact of the bearing pads on the behavior. The bearing pads were modeled with solid elements of ANSYS [28] using an equivalent modulus of elasticity of 10 ksi. The 3D FEM modeling techniques for the erected fit detailing method was accomplished by following the same steps used for 2D GA.

## **3.2.2 Comparison of Different Methods of Analysis**

Different methods of analysis discussed in the above sections were used to evaluate the structural responses for the erected fit detailing method at the TDL stage. These structural responses included the impact of layovers, vertical deflection, vertical reactions, flange lateral bending stress, and cross-frame forces. In the following sections, each structural response obtained from different methods of analysis is compared in order to recommend a method of analysis for calculating the structural responses.

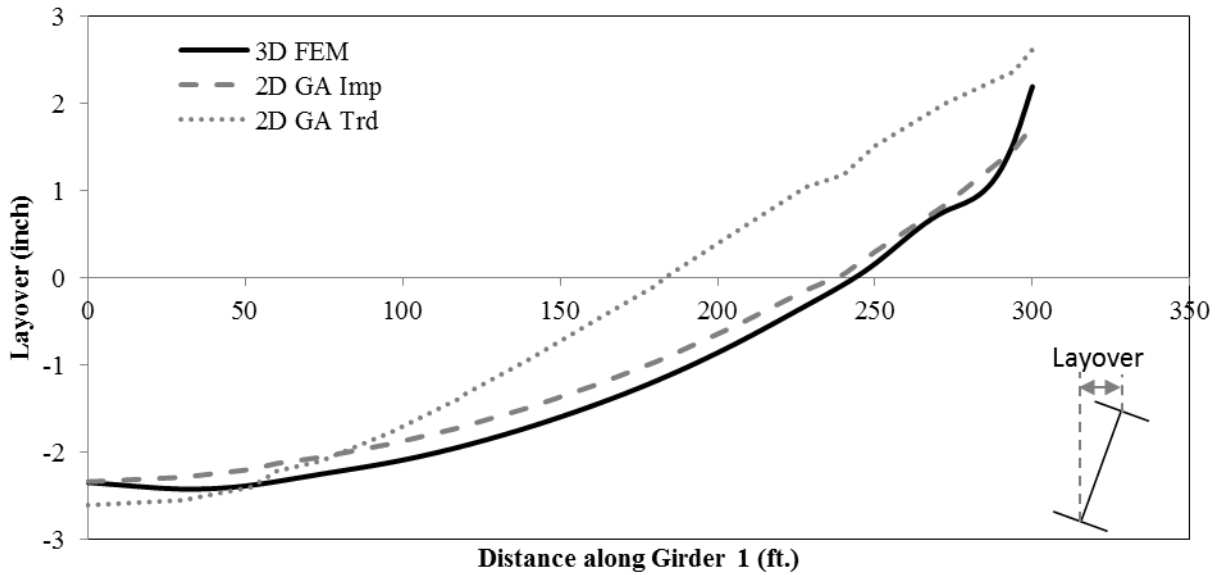
### *3.2.2.1 Layovers*

Layover is defined as the relative lateral displacement measured from the center of the top flange to the center of the bottom flange at any particular section of the girder. Layovers are basically a measure of the twist in the girders, and are expected to be affected by torsional stiffness of the girders and interaction between cross-frames and girders. The torsional stiffness of the girders is modeled more appropriately in the improved 2D-grid analysis compared to the traditional 2D-grid analysis. However, the arrangement of cross-frames can significantly affect the capability of an analysis method in the estimation of layovers.

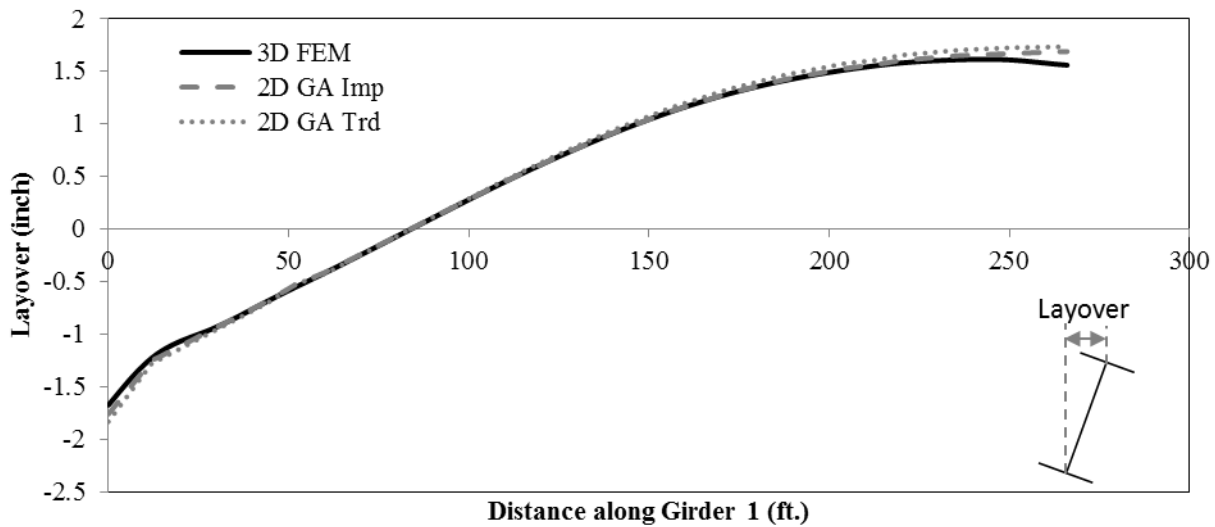
Layovers obtained from different methods of analysis are compared for Bridge A in Figure 3.5 and for Bridge B in Figure 3.6 for the erected fit detailing method at TDL stage. For Bridge A, traditional 2D

GA does not give a good estimate of the layovers. The difference between the layovers obtained from different methods of analysis is not significant for Bridge B.

It is recommended that the layovers be calculated using the improved 2D GA rather than the traditional 2D GA, since the improved method gives better estimates of the all responses, both for contiguous cross-frame and staggered cross-frames.



**Figure 3.5. Comparison of layovers calculated by different analysis method for Girder 1 of Bridge A.**



**Figure 3.6. Comparison of layovers calculated by different analysis method for Girder 1 of Bridge B.**

The traditional 2D GA provided poor estimates of layovers for Bridge A and good estimates of layovers for Bridge B. This is also true for other structural responses such as reactions and cross-frame forces, except for flange lateral bending stress,  $f_l$ . This because of the staggered framing used in the Bridge A compared to the contiguous framing used in Bridge B.

In the staggered framing, the intermediate (between the supports) cross-frames frame into the girders at non-contiguous points and forces in the cross-frames in the adjacent bays must be transferred through the girders. In contiguous framing, forces can be transferred directly from the cross-frames in adjacent bays. Therefore, in staggered framing, lack-of-fit effects are dependent on the torsional stiffness of the independent girders. Because the traditional 2D GA does not model the torsional stiffness of the independent girders, in the case of staggered framing Bridge A, the lack-of-fit affects are not estimated accurately.

In contiguous framing, adjacent cross-frames along contiguous line have a direct load path and can therefore transfer the forces through the gross frame line without relying on torsional stiffness of the girders. Therefore, lack-of-fit effects (except for flange lateral bending stress,  $f_l$ ) are not generally effected by torsional stiffness of the independent girders.

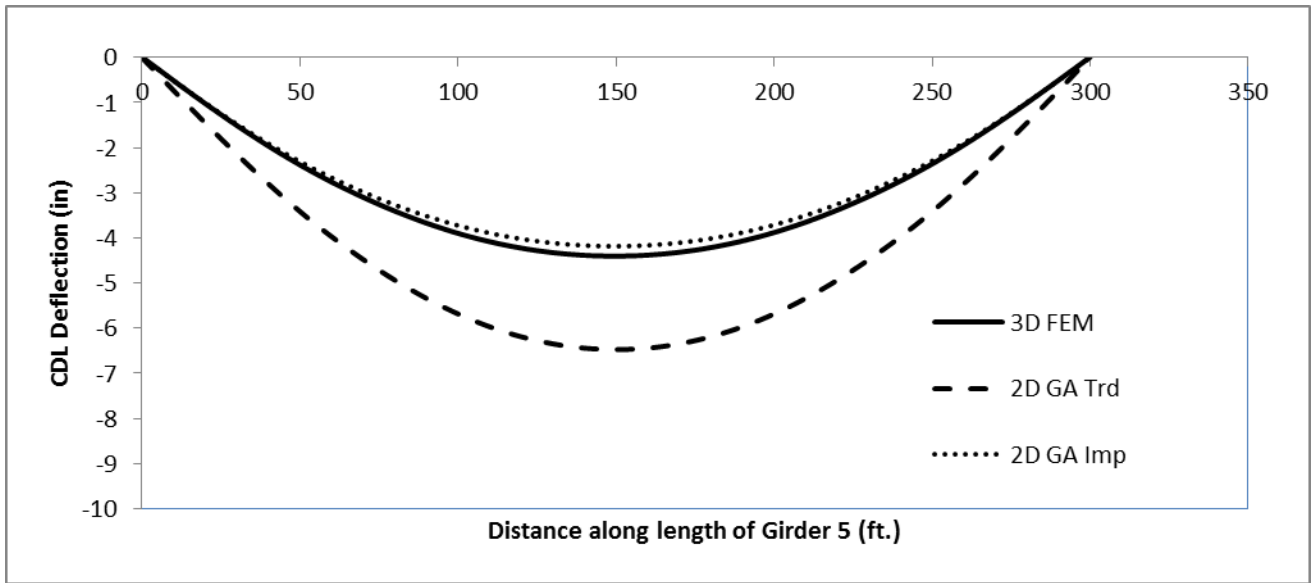
### 3.2.2.2 Vertical Deflection

The twist in the skew bridge, explained in the previous section, is accompanied by a component of vertical deflection. The capability of structural analysis to capture this component of vertical deflection largely depends on the torsional constant used for girders and interaction of the cross-frames and girders. It might be important to estimate the vertical deflections correctly because any overestimation or underestimation may increase fit-up issues during bridge erection.

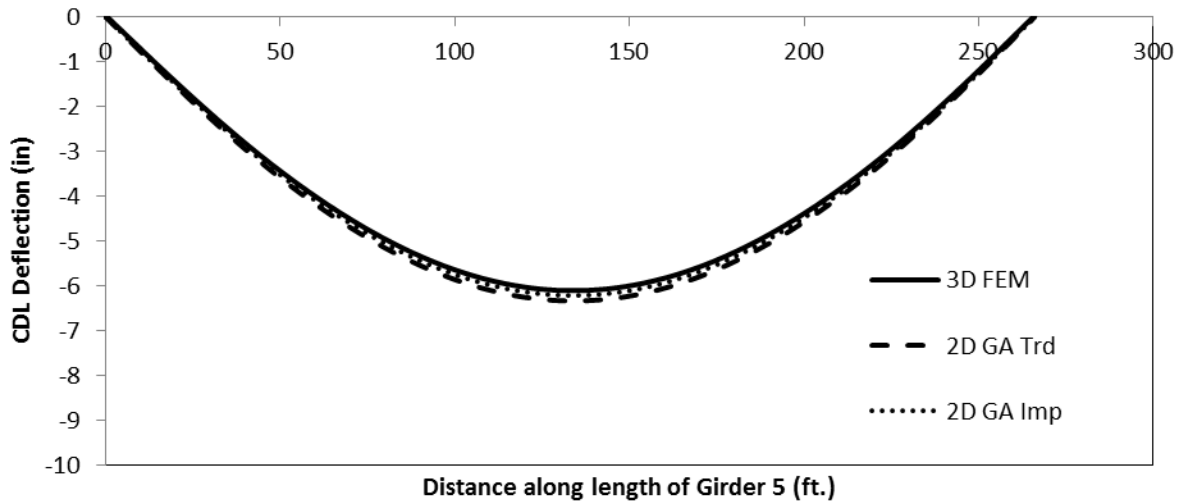
Steel dead load deflection for the erected fit detailing method can be estimated from a line girder analysis assuming the girder is placed on the supports without attaching cross-frames. The concrete dead load deflection should be calculated with cross-frames attached to the girders. Interior girders that are near the center of the bridge show more difference in vertical deflection calculated from different methods of analysis. For different methods of analysis considering the erected fit detailing method at the TDL stage, concrete dead load deflections are shown in Figure 3.7 for Girder 5 of Bridge A and in Figure 3.8 for Girder 5 of Bridge B.

For Bridge A the traditional 2D GA does not give a good estimate of the vertical deflection. The difference between the vertical deflections obtained from different methods of analysis is not significant for Bridge B.

(Note: Figure 3.7 and Figure 3.14 use 2D GA Trd to connote traditional 2D GA, 2D GA Imp to connote improved 2D GA, and CDL to connote concrete dead load.)



**Figure 3.7. Comparison of vertical deflection calculated by a different analysis method for Bridge A.**



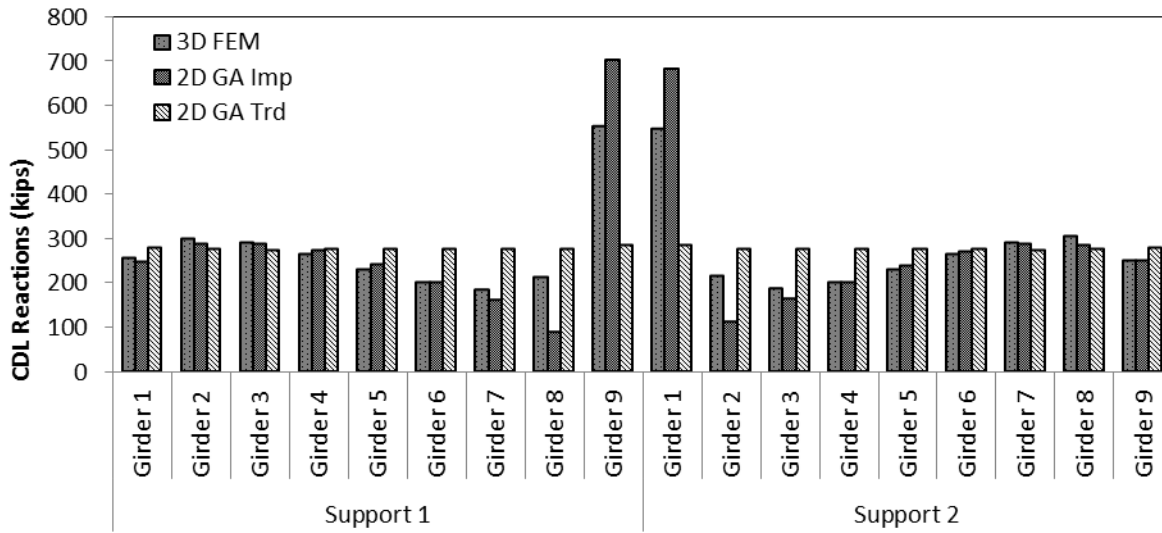
**Figure 3.8. Comparison of vertical deflection calculated by a different analysis method for Bridge B.**

### 3.2.2.3 Vertical Reactions

Vertical reactions are generally uniform for the straight bridges with zero skew given that all the girders are subject to same dead load. However, for skew bridges, vertical reactions are generally higher on the obtuse corners of the support compared to other locations. This is because of the existence of a stiff load path between the obtuse corners of the bridge.

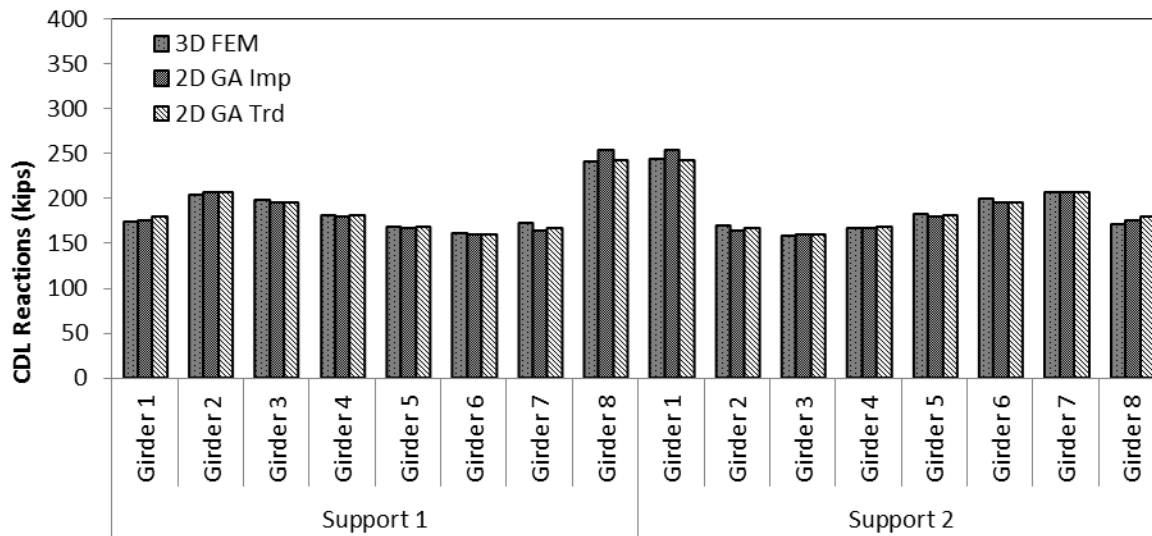
In order to check the capability of different methods of analysis to capture the variation in vertical reactions, the vertical reaction is compared for bridges with different framing plans. Vertical reactions obtained from different methods of analysis are compared for Bridge A in Figure 3.9 and for Bridge B in Figure 3.10 for the erected fit detailing method at the TDL stage.

The traditional 2D GA does not capture the variation in vertical reactions for Bridge A. However, the variation in reactions is captured for Bridge B by the analysis. The improved 2D GA gives the highest estimates of the vertical reactions. It can be concluded that the improved 2D GA is sufficient for calculating the vertical reactions.



**Figure 3.9. Comparison of vertical reactions calculated by different analysis methods for Bridge A.**





**Figure 3.10. Comparison of vertical reactions calculated by a different analysis methods for Bridge B.**

#### 3.2.2.4 Flange Lateral Bending Stress ( $f_l$ )

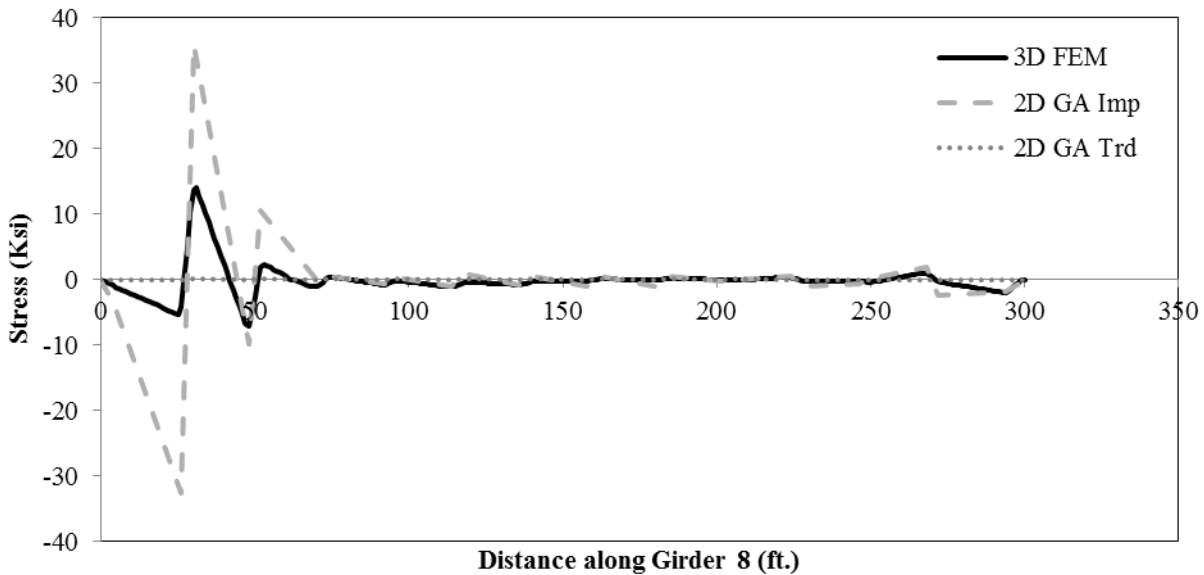
A procedure to calculate flange lateral stress from the 2D GA for the erected fit detailing method has been specified in literature [6] [26]. A brief summary of the procedure is provided here. The displacements corresponding to concrete dead load from the 2D GA method are used to calculate forces in cross-frame members. These forces are then resolved into vertical and lateral components at the connection point of the cross-frame and girder. The flange is assumed simply supported or fixed ended between the connections adjacent to the connection at which lateral forces are obtained. Using the lateral bending moment at the location of lateral load of this idealized beam model, lateral stress is calculated using flexural formula.

Flange lateral bending stresses obtained from different methods of analysis are compared for Bridge A in Figure 3.11 and for Bridge B in Figure 3.12 for the erected fit detailing method at the TDL stage. It can be noted in both Figure 3.11 and Figure 3.12 that  $f_l$  is almost zero for the traditional 2D GA which does not include the warping stiffness in modeling the torsional stiffness of girders. More appropriate values of  $f_l$  are obtained by more accurately modeling the torsional stiffness of the girder, i.e., taking into account the warping torsional stiffness that will be there during twist of the girders. As noted earlier, the warping torsional stiffness was incorporated into the improved 2D GA. As expected, the increase in the

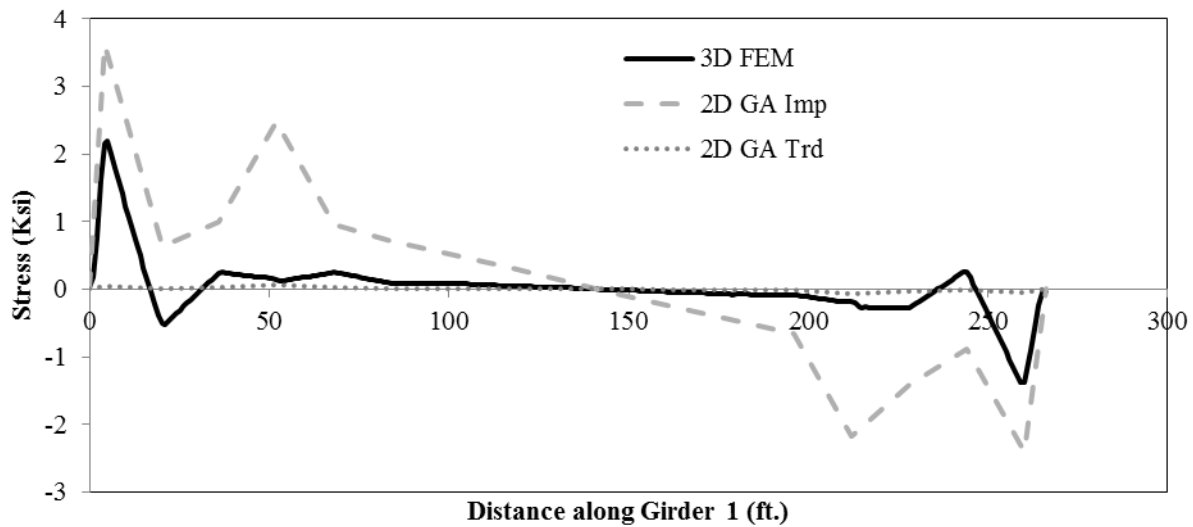
torsional stiffness of the girder by incorporating the warping stiffness attracts more force and therefore flange lateral bending stresses increase. The effect is more pronounced in the flange lateral bending stress compared to observations related to the deflections since relatively small movements can have large effects in stress.

In the improved 2D GA two assumptions can be made for the segment of girder between three consecutive cross-frames for calculation of lateral moment as explained in NCHRP 725 [6]. Assuming simply supported (s-s) boundary conditions for the segment gives more value of lateral moment and thereby results in conservative estimates of  $f_i$ , whereas assuming fix-fix boundary conditions for the segment gives unconservative estimates of  $f_i$ . In reality, the boundary conditions are somewhere between the fix-fix and s-s cases, however the exact boundary conditions are difficult to model. Results of this study indicate that the average of  $f_i$  values obtained based on the two assumptions constitutes an acceptable approach, which is in agreement with the recommendations of NCHRP 725 [3].

It could be concluded that the improved 2D GA with an average value of  $f_i$  constitutes an acceptable approach to approximate  $f_i$ .



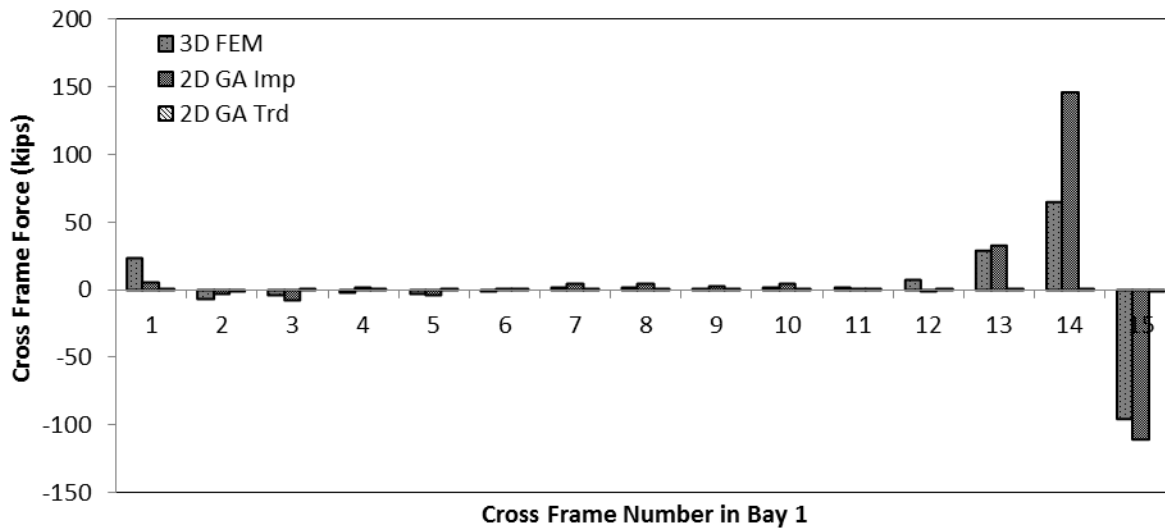
**Figure 3.11. Comparison of flange lateral bending stress calculated by different analysis methods in Girder 8 of Bridge A—erected fit at the TDL stage.**



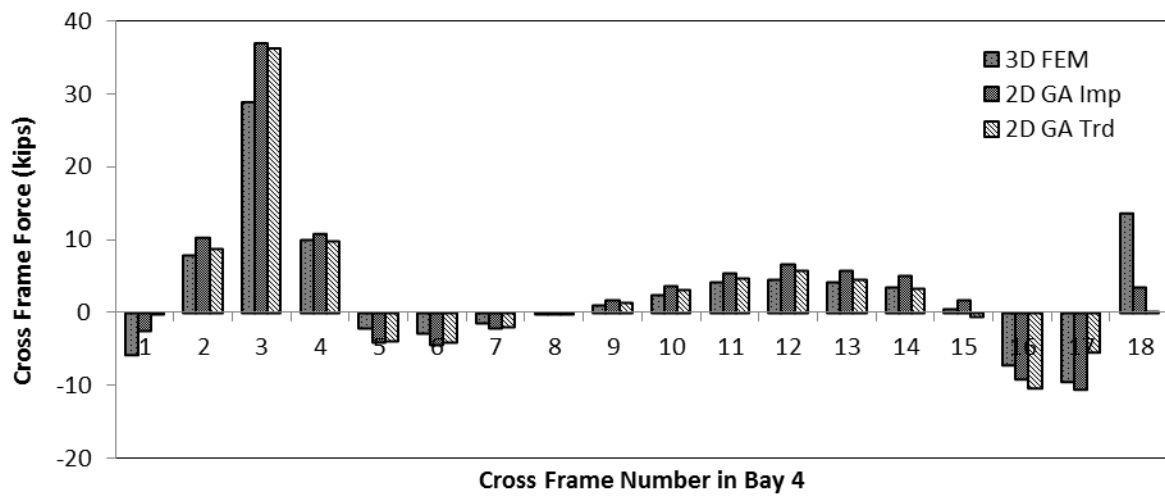
**Figure 3.12. Comparison of flange lateral bending stress calculated by different analysis methods in Girder 4 of Bridge B—erected fit at the TDL stage.**

### 3.2.2.5 Cross-frame Forces

Comparisons were made of the cross-frame forces obtained from different methods of analysis for Bridge A in Figure 3.13 and for Bridge B in Figure 3.14 for the erected fit detailing method at the TDL stage. It can be observed that the difference between the cross-frame forces obtained from the different methods of analysis is significant. The comparisons also indicate that the cross-frame forces are highest for the improved 2D GA and lowest for the 3D FEM with bearing pads modeled for Bridge A. The improved 2D GA significantly over estimates the trend in the 3D FEM forces compared to the traditional 2D GA forces in a few of the bays. The traditional 2D GA forces are essentially zero due to the gross underestimation of the girder torsional stiffness in the traditional 2DGA. The difference in the cross-frame forces for Bridge B is not very significant. The results of a broad range of analyses on the different bridges demonstrate that in general the improved 2 GA is sufficient to calculate the cross-frame forces. Although the results are on the generally on the conservative side, the improved 2D GA provides a reasonable level of accuracy compared to 3D FEM.



**Figure 3.13. Comparison of cross-frame forces calculated by a different analysis method for Bridge A—erected fit at the TDL stage.**



**Figure 3.14. Comparison of cross-frame forces calculated by different analysis method for Bridge B—erected fit at the TDL stage**

### 3.3 Final Fit Detailing Method

For the bridges detailed with the final fit detailing method, the cross-frames will not fit at the SDL stage and therefore, forces are induced into the cross-frames. The cross-frame forces at the SDL forces would be referred to as forces due to the lack-of-fit. Due to this lack-of-fit, additional structural responses appear in the cross-frame at SDL stage. In past studies, these structural responses are generally evaluated from 3D FEM analysis, by using initial strains. Calculation of the initial strain based on the camber diagram for every single cross-frame in the structure is a time-consuming task. Section 3.3.1 describes two alternative methods to estimate the structural response for final fit detailing method at SDL stage. These methods do not use initial strains. An overview of the methods is provided in the following section.

#### 3.3.1 Methods of Analysis

Different methods of analysis can be used to calculate lack-of-fit effects for the final fit detailing method at the SDL stage. These methods are:

- Reversing the 2D GA results for erected fit,
- 3D FEM using initial strains, and
- 3D FEM using element birth and death options for the cross-frames.

The following sections provide a discussion on each method.

##### 3.3.1.1 *Reversing 2D GA Results for Erected Fit*

Recent study has shown that the lack-of-fit effects for the final fit detailing method at the SDL stage are equal and opposite to the lack-of-fit effects for the erected fit detailing method at the TDL stage [29]. Lack-of-fit effects for the erected fit detailing method at the TDL stage can be obtained from grid analysis and reversing the sign of the brace forces to obtain the lack-of-fit effects for the final fit detailing method at the SDL stage.

##### 3.3.1.2 *3D FEM Using Initial Strains*

In this procedure, initial strains are used to model lack-of-fit at the SDL stage for the final fit detailing method.

The configurations of cross-frames and girders to calculate the initial strain are shown in Figure 3.15 for the intermediate cross-frames perpendicular to web, and in Figure 3.16 for the cross-frame parallel to skew. Configuration 1 represents a real situation in which cross-frames do not fit between the girders at the SDL stage for the final fit detailing method. Configuration 2 represents an imaginary condition in

which cross-frames are deformed to make the connections that were not established in Configuration 1. Configuration 2 is an imaginary high-energy configuration of the system. Once the system is allowed to establish equilibrium, it attains its lowest energy state. After equilibrium is established, the system has the real configuration of steel framing after attaching the cross-frame for the final fit detailing method at the SDL stage.

The initial strain,  $\varepsilon_{initial}$  in any cross-frame member can be calculated using the following formula:

$$\varepsilon_{initial} = \frac{L_1 - L_2}{L_2} \quad (19)$$

Where,  $L_1$  is the length of the cross-frame member in Configuration 1, and  $L_2$  is the length of the cross-frame member in Configuration 2.

The two configurations of the cross-frames are shown 1) for the cross-frame that are perpendicular to web in Figure 3.15, and 2) for the cross-frames parallel to skew in Figure 3.16.

The length of the cross-frame members that are perpendicular to girder web in Configuration 1 as shown in Figure 3.15 can be calculated as follows:

$$L_{TC_1} = L_{BC_1} = S \quad (20a)$$

$$L_{D1_1} = L_{D2_1} = \sqrt{S^2 + h_b^2} \quad (20b)$$

Where  $L_{TC_1}, L_{BC_1}, L_{D1_1}, L_{D2_1}$  are lengths of top chord (TC), bottom chord (BC), diagonal 1 (D1) and diagonal 2 (D2), members of the cross-frame in Configuration 1,  $S$  is spacing between the girders, and  $h_b$  is height of bracing.

Similarly, the length of the cross-frame members that are perpendicular to web in Configuration 2 of Figure 3.15 can be calculated as follows:

$$L_{TC_2} = L_{BC_2} = \sqrt{S^2 + \Delta^2} \tag{21a}$$

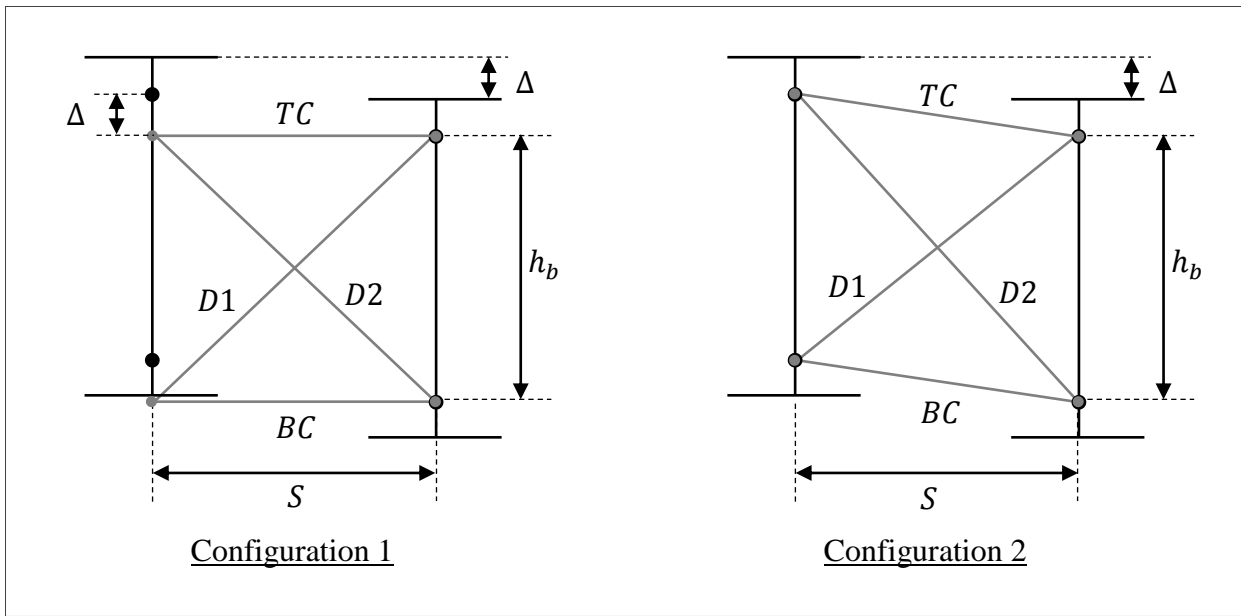
$$L_{D1_2} = \sqrt{S^2 + (h_b - \Delta)^2} \tag{21b}$$

$$L_{D2_2} = \sqrt{S^2 + (h_b + \Delta)^2} \tag{21c}$$

Where  $L_{TC_2}, L_{BC_2}, L_{D1_2}, L_{D2_2}$  are lengths of TC, BC, D1, and D2 members of the cross-frame in Configuration 2.

$\Delta$  is the difference in elevation of the girder's cross-section connected by the cross-frame and can be obtained from the concrete dead load camber calculated from LGA or isolated girder analysis (IGA). It is worth noting that  $\Delta$  is obtained from the concrete dead load camber calculated from deflection of system of girders and cross-frames attached together in NCHRP 725 [6]. This is an incorrect way of calculating  $\Delta$  for the final fit detailing method at SDL stage as explained elsewhere [29].

It should be noted that  $\Delta$  is the difference in elevation of girders to calculate the initial strains that will simulate lack-of-fit due to concrete dead load and is different from the real value of  $\Delta$  that will exist between the girders at the SDL stage.



**Figure 3.15. Configurations to calculate initial strain in the cross-frames that are perpendicular to girder web.**

Lack-of-fit in the cross-frames that are parallel to the skew supports occurs due to major axis bending rotation of the girder section as shown in Figure 3.16. Figure 3.16 illustrates the configuration of the cross-frames parallel to skewed support at the bearing lines, however the intermediate cross-frames parallel to skew shall have the similar configurations. Configuration 1 in Figure 3.16 shows that the cross-frame does not fit between the girders due to major axis bending rotation,  $\phi$  at the ends. In configuration 2, the cross-frame is deformed to establish the connections as described previously for the cross-frames perpendicular to the girder web.

The length of the cross-frame members that are parallel to the skew supports in Configuration 1 shown in Figure 3.16 can be calculated as follows:

$$L_{TC_1} = L_{BC_1} = \sqrt{\Delta_x^2 + S^2} \quad (22a)$$



$$L_{D1_1} = L_{D2_1} = \sqrt{\Delta_x^2 + h_b^2 + S^2} \quad (22a)$$

Neglecting the displacement in the Y-direction of the connection points and assuming small deflections so that  $\sin \theta \cong \theta$  it can be shown that the length of the cross-frame members that are parallel to the skew supports in Configuration 2 can be determined as follows:

$$L_{TC_2} = L_{BC_2} = \sqrt{\Delta_x^2 + S^2} \quad (23a)$$

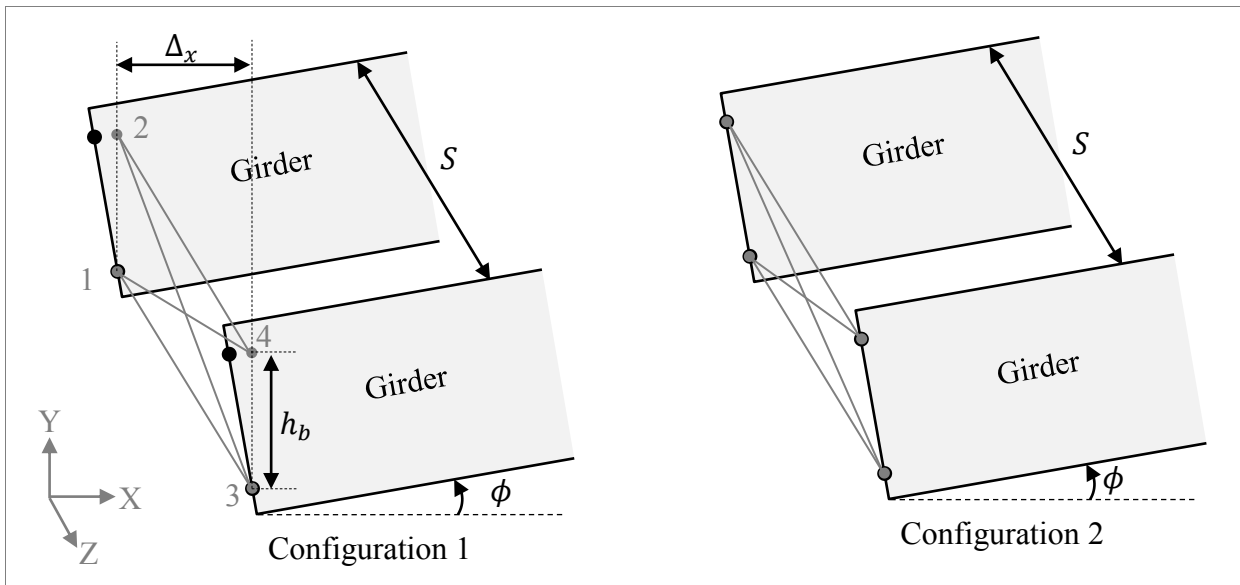
$$L_{D1_2} = \sqrt{(\Delta_x - \phi \cdot h_b)^2 + h_b^2 + S^2} \quad (23b)$$

$$L_{D2_2} = \sqrt{(\Delta_x + \phi \cdot h_b)^2 + h_b^2 + S^2} \quad (23c)$$

And

$$\Delta_x = S \times \tan \theta \quad (23d)$$

Where,  $\theta$  is the skew angle, and  $\phi$  is the major axis bending rotation due to concrete dead load at the location of the cross-frame. The rotation,  $\phi$  is positive (counter clockwise) for the bearing line having Girder 1 at the acute corner and is negative (clockwise) for the bearing line having Girder 1 at the obtuse corner.



**Figure 3.16: Configurations to calculate initial strain in the cross-frames that are parallel to skew**

In order to get the SDL configuration for final fit detailing method, the complete model of the bridge is built with cross-frames attached to the girders. A particular value of initial strain is assigned to each cross-frame member that can be calculated based on location and orientation of the cross-frame and type of the cross-frame member. Once initial strains are assigned to all the cross-frame members, a static analysis is run without applying any external load. In the static analysis the cross-frame members expand or contract depending on the initial strain value and establish equilibrium with the girders. Once equilibrium is established the steel framing of bridge achieves its stable lowest possible energy configuration. The geometry of the bridge obtained after the equilibrium is established represents the bridge geometry at the SDL stage for the final fit detailing method.

### 3.3.1.3 3D FEM Using Element Birth and Death to Model the Cross-frames

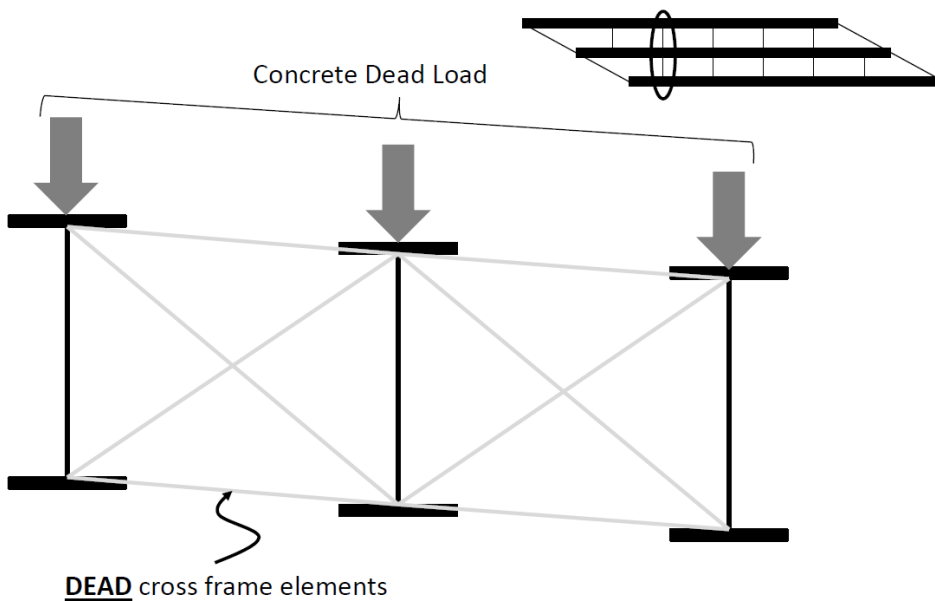
In the final fit detailing method, cross-frames are detailed to fit between the girders after application of the concrete dead load. As a result, the cross-frames will possess a fit-up force at the SDL stage. Lack-of-fit at the SDL stage for the final fit detailing method can be simulated by using birth and death options for the cross-frame elements. Many software packages have birth and death options in which elements can be activated and deactivated at different stages in the loading history. The terms “birth” and “death” refer to the respective state of the element being either “alive” or “dead”. Elements that are

“dead” are assigned a zero stiffness value, while elements that are “alive” possess the assigned stiffness in the model. Although an element that is “dead” will deform or strain as the structure is displaced, the element does not develop any stress since it has zero stiffness. Depending on the type of analysis, elements can be brought alive or dead repeatedly in the analysis at any desired stage.

In this analysis concrete dead load is applied on the girders to deflect the girders to a position where cross-frames fit between them. Once the girders are deflected by concrete dead load, the cross-frames are made alive. After that, concrete dead load is removed to get the SDL responses for final fit detailing method.

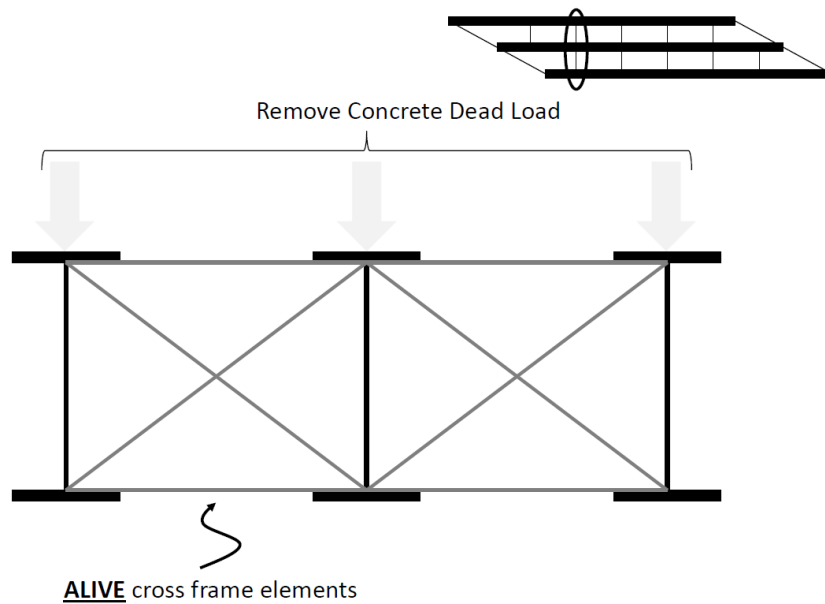
It is a two-step FEM analysis after completing the bridge geometry with cross-frames attached.

**Step 1:** All the cross-frame elements are killed (using EKILL command in ANSYS) and concrete dead load is applied as shown in Figure 3.17.



**Figure 3.17. Application of concrete dead load on girders after killing cross-frame elements.**

**Step 2:** After the concrete dead load has deflected the girders, all the cross-frame elements are made alive (using EALIVE command in ANSYS) and the concrete dead load is removed (made zero) as shown in Figure 3.18.



**Figure 3.18. Removal of concrete dead load from girders after making cross-frame elements alive.**

At the completion of Step 2, the SDL configuration of bridge framing is obtained for the final fit detailing method.

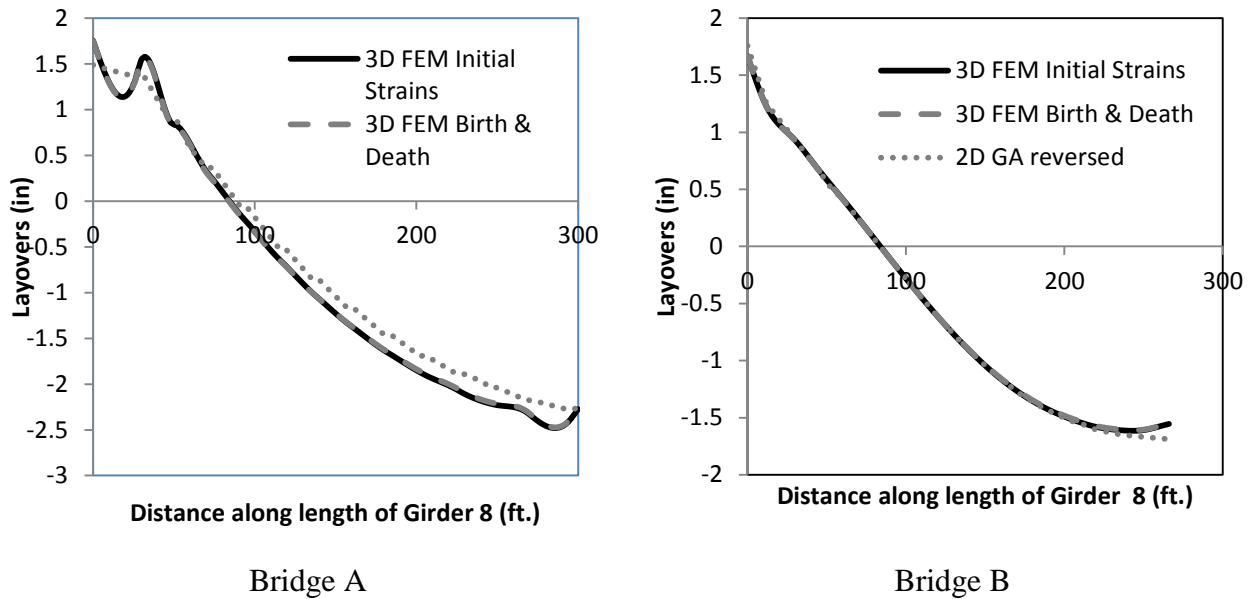
It is worth noting that this method does not involve laborious calculation of initial strain for every single cross-frame member and gives the same results as the method of initial strains. Many software packages allow the user to select a certain subset of the elements to assign a given property. In the case of ANSYS, a specific group of cross-frames can be assigned a different material (MAT constant) or other cross-sectional property (REAL constant). Therefore when the user wants to bring a certain set of the cross-frames “alive” or “dead” a group braces can be quickly selected.

Section 4.2 includes a detailed comparison of different responses obtained from different methods of analysis.

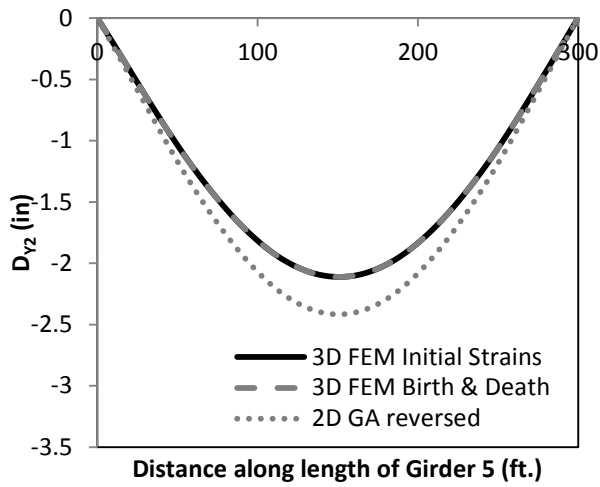
### 3.3.2 Comparison of Different Methods of Analysis

Different lack-of-fit effects such as layovers, component of deflection due to lack-of-fit ( $D_{Y2}$ ), component of reaction due to lack-of-fit ( $R_{Y2}$ ), flange lateral bending stress ( $f_l$ ), and cross-frame forces are compared for different methods of analysis in Figure 3.19 to Figure 3.23 for the final fit detailing method at the SDL stage. The 3D FEM analysis using initial strains (3D FEM Initial Strains) and 3D

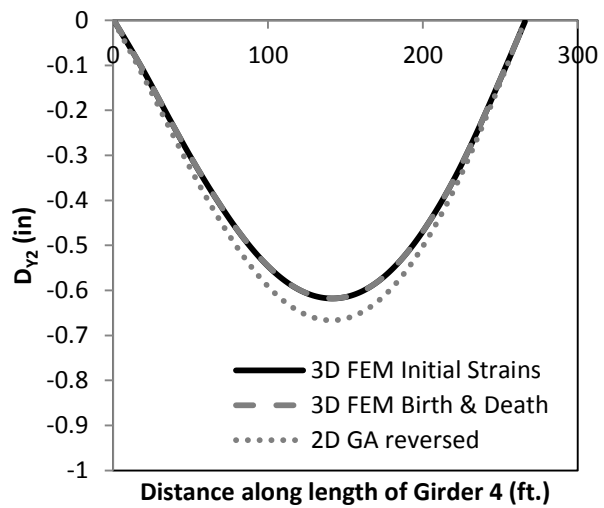
FEM analysis using element birth and death techniques in the modeling of the cross-frames (3D FEM Birth & Death) gives almost the same estimates of different lack-of-fit effects for Bridge A and Bridge B. Reasonable estimates of lack-of-fit effects are obtained by reversing the improved 2D GA for both bridges.



**Figure 3.19. Comparison of layovers calculated by different analysis methods—final fit at the SDL stage.**

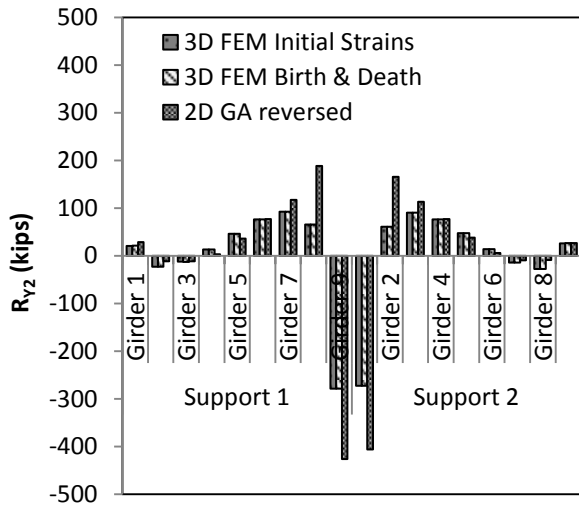


Bridge A

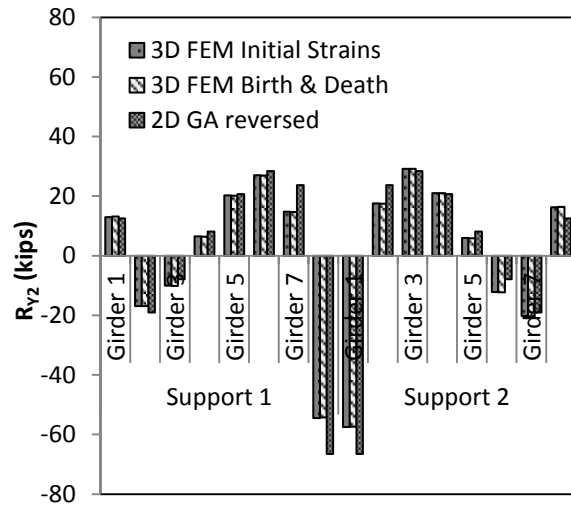


Bridge B

Figure 3.20. Comparison of component of deflection due to lack-of-fit ( $D_{Y2}$ ) calculated by different analysis methods.

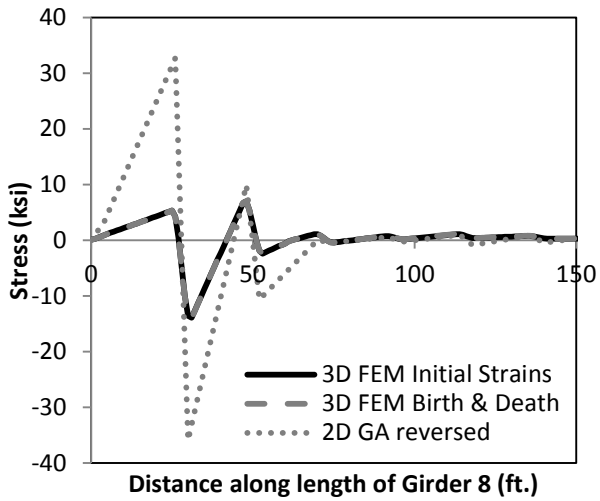


Bridge A

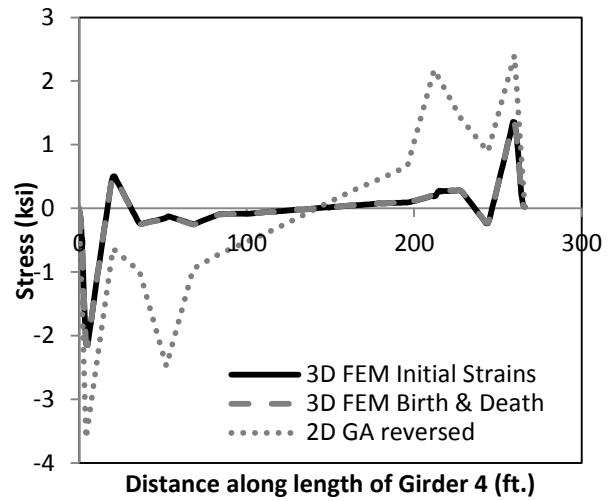


Bridge B

Figure 3.21. Comparison of change in reactions due to lack-of-fit ( $R_{Y2}$ ) calculated by different analysis method for Bridge A.

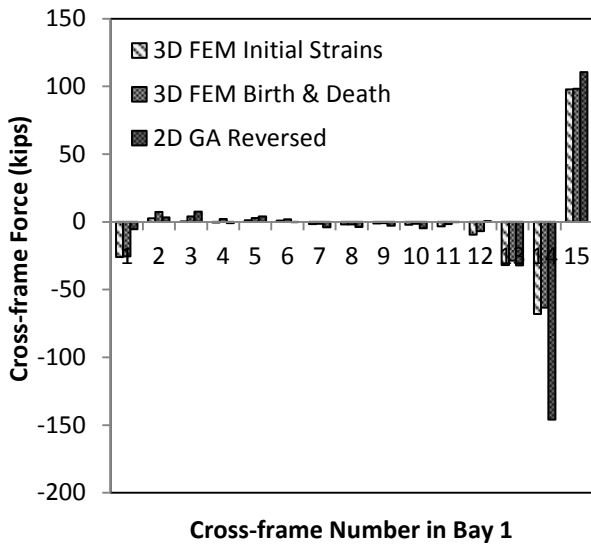


Bridge A

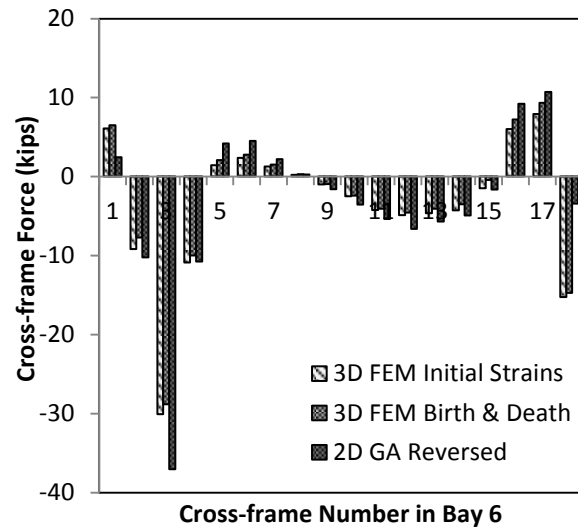


Bridge B

Figure 3.22. Comparison of flange lateral bending stress calculated by different analysis methods.



Bridge A



Bridge B

Figure 3.23. Comparison of cross-frame forces calculated by different analysis methods.

### 3.4 Summary

For the erected fit detailing method, the performance of the improved and traditional 2D GA is a function of the cross-frame details that are specified as shown in Table 3.1:

For bridges with contiguous cross-frames, the traditional 2D GA gives reasonable estimates of all responses, except for flange lateral bending stress. The improved 2D GA gives reasonable estimates of all responses.

For bridges with staggered cross-frame, the traditional 2D GA gives erroneous estimates of all the responses, and improved 2D GA gives reasonable estimates of all responses. However, when the stagger offset distance is small,  $J_{eq}$  in the improved 2D GA has very high value resulting in overestimation of lack-of-fit effects.

**Table 3.1. Performance of traditional and improved 2D GA**

Lack-of-fit effect	Staggered cross-frames		Contiguous cross-frames	
	Traditional 2D GA	Improved 2D GA	Traditional 2D GA	Improved 2D GA
Girder Layovers	Poor	Ok	Ok	Ok
Vertical Reaction	Poor	Ok	Ok	Ok
Cross-frame forces	Poor	Ok	Ok	Ok
Vertical Deflection	Poor	Ok	Ok	Ok
Flange lateral bending stress	Poor	Ok	Poor	Ok

The structural response due to lack-of-fit for the final fit detailing method at the SDL stage obtained from the method of initial strain had good agreement with the structural response obtained from the method utilizing element birth and death concepts to simulate the cross-frames. Reversing the improved 2D GA results for the erected fit detailing method at the TDL stage also gave reasonable estimates of the lack-of-fit effects for the final fit detailing method at the SDL stage.

The improved 2D GA can be used to estimate different structural responses, including cross-frame forces due to lack-of-fit in straight skewed bridges detailed with the final fit or erected fit detailing method.



This chapter provides different simplified methods for estimating the cross-frame forces and other structural responses in straight skewed bridges. The next chapter discusses different design methods that can be used for sizing the cross-frame members.

## 4 Design Approaches for Sizing Cross-frames

This chapter discusses different design approaches for designing cross-frames for straight non-skewed bridges, straight skewed bridges, and horizontally-curved bridges. There are some general design issues related to the cross-frames that should be addressed before sizing the cross-frame members. These issues include the following

- Framing layout
- Detailing method
- Cross-frame configuration

These issues can significantly affect the response of the girders and bracing and their design, particularly for cases with skewed and horizontally curved bridges. There are certain framing layouts that might be economical from the design perspective; however, these layouts might be very expensive from a detailing point of view. Similarly methods of detailing the cross-frames potentially can have a significant effect on the erection of skewed and horizontally curved bridges.

After selecting a particular framing layout, detailing method and cross-frame configuration, cross-frame members can be sized to meet the AASHTO or AISC requirements.

The following sections provide a discussion of some of the general design issues related to cross-frames, followed by different procedures that can be used to size the cross-frame members.

## 4.1 Framing Layout

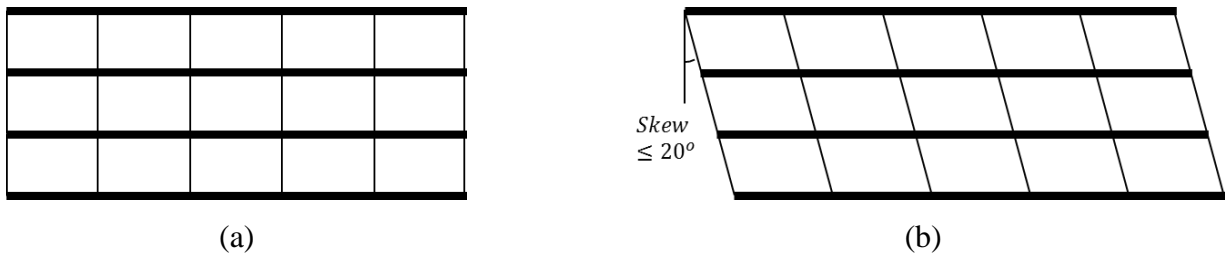
Different framing layouts can be used depending on the geometric shape of the bridge. The following section provides a discussion of the framing layouts for the following bridge configurations

- Straight non-skewed bridges or bridges with skew  $\leq 20^\circ$
- Skewed bridges with skew  $\geq 20^\circ$
- Horizontally curved bridges

FDOT structure design guidelines [30] section 5.7.B. states, “For straight I-girder units where supports are parallel and all supports are skewed less than or equal to  $20^\circ$ , orient cross-frames parallel to the supports. In general, for all other cases, orient cross-frames radial or normal to girder lines.”

### 4.1.1 Straight Bridges with Skew $< 20^\circ$

AASHTO LRFD [2] provides clear guidelines for framing layout in straight bridges with skew  $\leq 20^\circ$ . AASHTO article 6.7.4.2 states, “Where supports are not skewed more than  $20^\circ$ , intermediate diaphragms or cross-frames may be placed in contiguous skewed line parallel to skewed supports.” Therefore, for straight bridges having skew less than  $20^\circ$ , cross-frame are generally arranged in contiguous lines parallel to support as depicted in Figure 4.1.

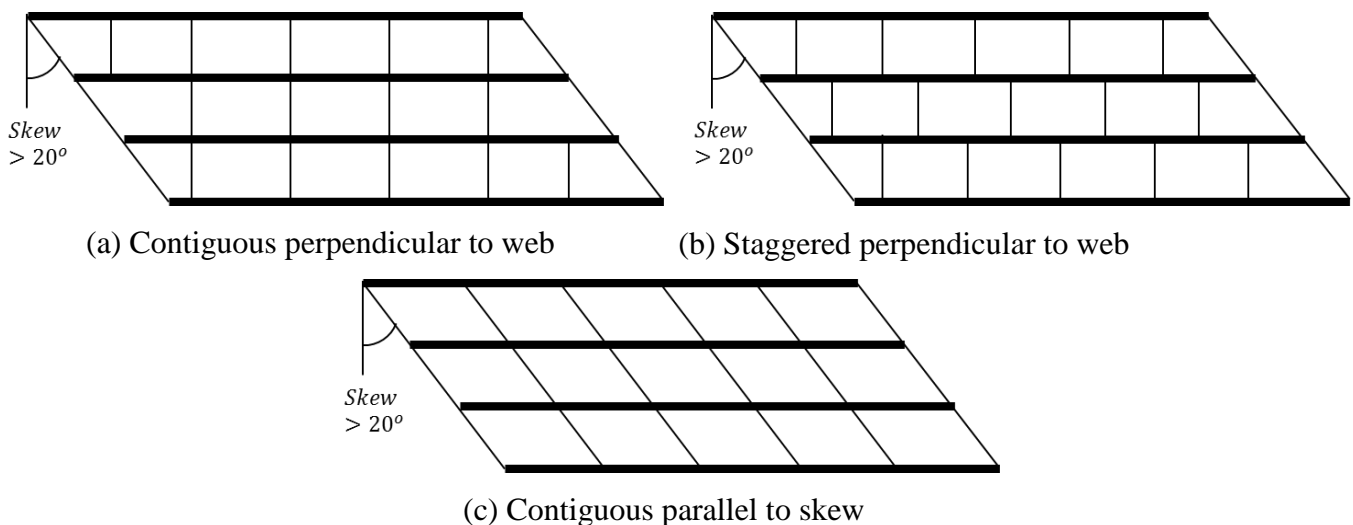


**Figure 4.1. Framing layout for straight bridges with skew less than 20 degrees**

### 4.1.2 Straight Bridges with Skew $\geq 20^\circ$ Equal for All Support

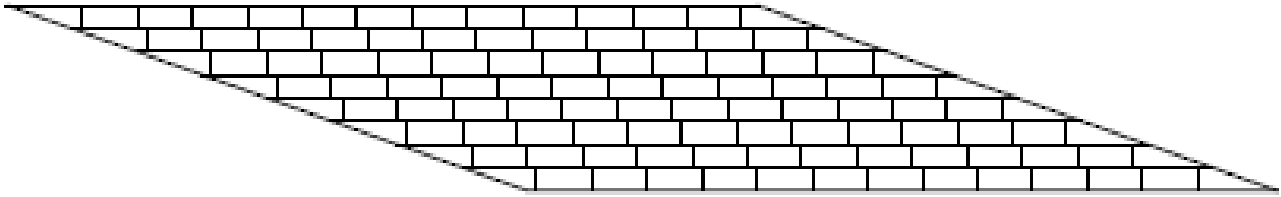
Different framing layouts for the straight bridges with equal skews at all supports and a skew angle greater than 20 degrees, are depicted in Figure 4.2. It is important to note that cross-frames at the end supports are always parallel to skew supports. For the intermediate support in case of a continuous bridge the cross-frames are either arranged parallel to intermediate supports or perpendicular to web. For the end diaphragms or cross-frame parallel to skew, generally, a bent-plate connection is often used to connect the cross-frames to girders.

The framing plan having intermediate cross-frames perpendicular to web arranged in contiguous lines as shown in Figure 4.2(a) has the tendency to develop large cross-frame forces especially near the obtuse corners of the bridge. However, this framing plan tends to develop less flange lateral bending stress. The framing plan shown in Figure 4.2(b) has intermediate cross-frames perpendicular to the web but staggered to avoid direct contact with cross-frames in adjacent bays. Staggered cross-frames are well known for decreasing the cross-frame forces and increasing the flange lateral bending stress as stated in AASHTO LRFD [31] article C6.7.4.2. Further, AASHTO LRFD [31] article C6.7.4.2 requires a special investigation of flange lateral moments and cross-frame forces for the staggered cross-frames. Further, as mentioned in Chapter 3, improved 2D-grid analyses tend to overestimate cross-frame forces and flange lateral bending stresses if the stagger distance is relatively small.

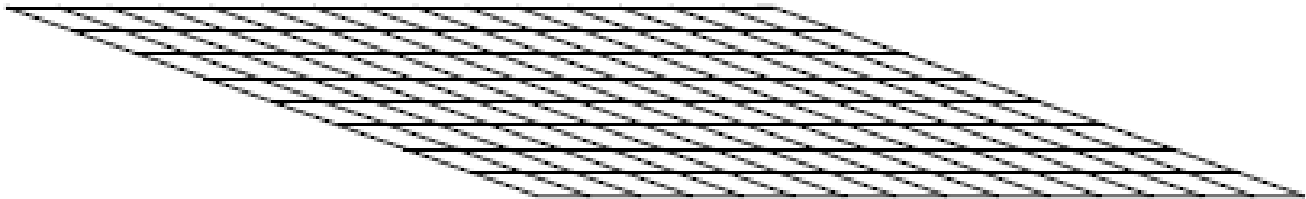


**Figure 4.2. Framing layout for straight bridges having skew greater than 20 degrees equal for all supports**

Arranging intermediate cross-frames parallel to skewed supports as shown in Figure 4.2(c) might be considered to reduce the distortion or layovers in the bridge. The effectiveness of intermediate cross-frames to reduce the layover is studied by comparing two framing options for Bridge A. In framing plan 1, the cross-frames are attached perpendicular to girder and are staggered along the length of the bridge as shown in Figure 4.3a. In framing plan 2, the cross-frames are placed parallel to the skewed supports with a typical cross-frame spacing of 20ft as shown in Figure 4.3b.



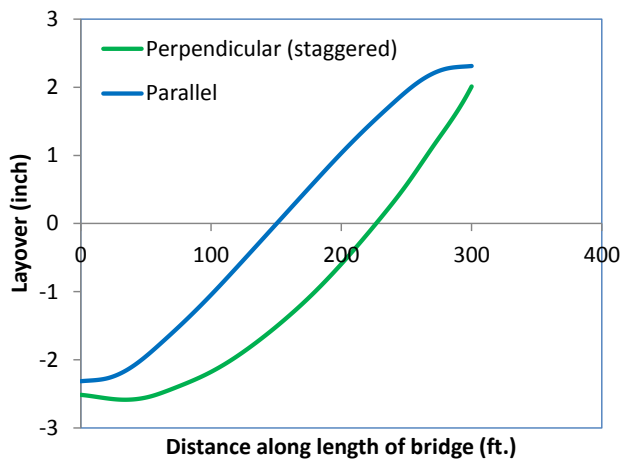
(a) Framing Plan 1



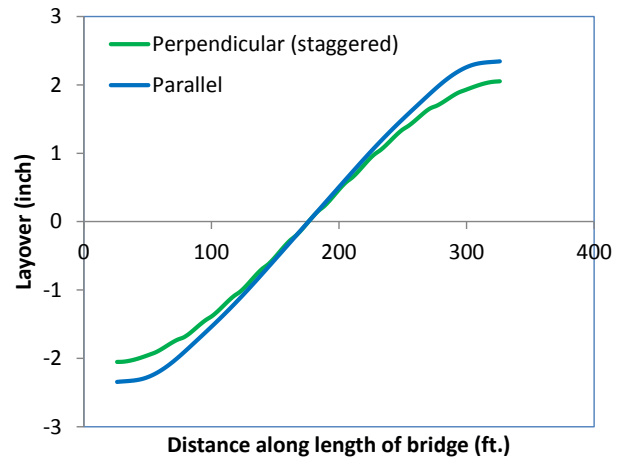
(b) Framing Plan 2

**Figure 4.3: Different cross-frame orientations**

Comparison of layovers obtained for different framing options are shown for Girder 1 and Girder 5 of Bridge A in Figure 4.4. These layovers are calculated by applying the concrete dead on the system of girders attached with cross-frames detailed with the erected fit detailing method. In Girder 1, the layovers are higher for framing plan 1 compared to the layovers obtained for framing plan 2. For Girder 5 the layovers are less for framing plane 1 compared to framing plane 2. However, in both case the difference in layovers is not that significant. Results of the study indicate that having the cross-frame parallel to skew does not significantly reduce the layovers. When cross-frames are parallel to the skew, they still cause twist of the girder, because the axis of rotation of these cross-frames is not parallel to the axis of rotation for the major bending axis of the girders.



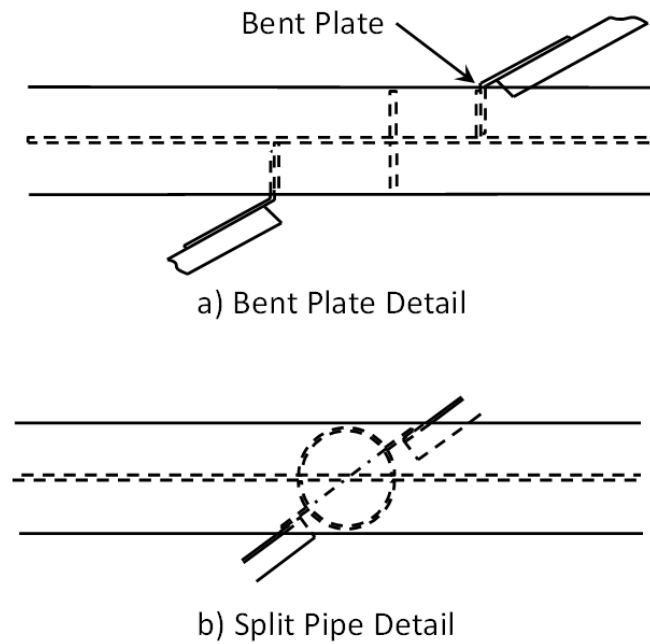
(a) Girder 1



(b) Girder 5

**Figure 4.4: Layover for different cross-frame orientations- erected fit at the TDL stage**

The results show that arranging the cross-frame parallel to the skew does not help in reducing the girder twist. Further, arranging the intermediate cross-frames parallel to the skewed supports might need a bent plate connection or split pipe detail as shown in Figure 4.5. The bent-plate detail is frequently used by fabricators due to the ease welding and connecting the stiffeners and cross-frames. It is important to mention that Bridge Welding Code [32] does not cover pipe, therefore, qualification testing might be required to use the split pipe as a stiffener. The pipe stiffener shall enclose an area of girder that shall be difficult to inspect for corrosion. Calculating the capacity of pipe stiffener for carrying compressive and tensile load, from load bearing cross-frames, shall complicate the design of steel bridge. The behavior of the bent-plate and split pipe details from a static, stiffness, and fatigue behavior are discussed in literature [33].

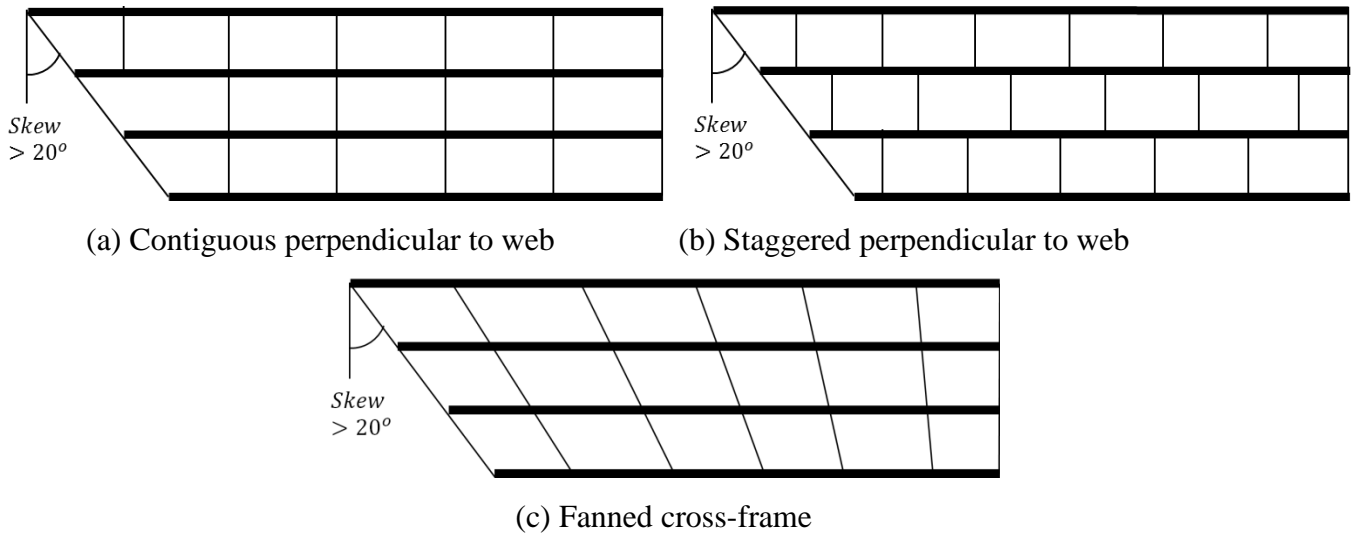


**Figure 4.5: Bent plate and split pipe details.**

Arranging the intermediate cross-frames parallel to the skew also requires longer cross-frame members. Therefore, satisfying AASHTO LRFD [2] slenderness ratio might require larger member areas of the cross-frame member, thereby reducing the economy. As a result, for larger skew angles ( $>20$  degrees) it is not generally recommended to arrange the intermediate cross-frames parallel to skew. If a designer does decide to arrange the intermediate cross-frames parallel to the skew, the bent plate detail should not be used due to a reduction in the stiffness of the resulting system.

### 4.1.3 Straight Bridges with Skew $\geq 20^\circ$ Not Equal for All Support

Three framing options for the straight bridges with unequal skew are shown in Figure 4.6(a) (b) and (c). The first two framing options have similar strengths and limitations as discussed in section 4.1.2. Figure 4.6(c) depicts a fanned cross-frame arrangement for the bridges with unequal skew. An earlier study [26] showed that the fanned cross-frame layout shown in Figure 4.6 or similar types of framing with elimination of some more cross-frames are efficient in diminishing the skew effect. However, the fanned framing or similar type of framing requires different angles of intersect at each cross-frame line, leaving more opportunity for error. In fanned framing every single cross-frame has a different length that requires each cross-frame to be fabricated differently which will likely dramatically increase the fabrication costs.

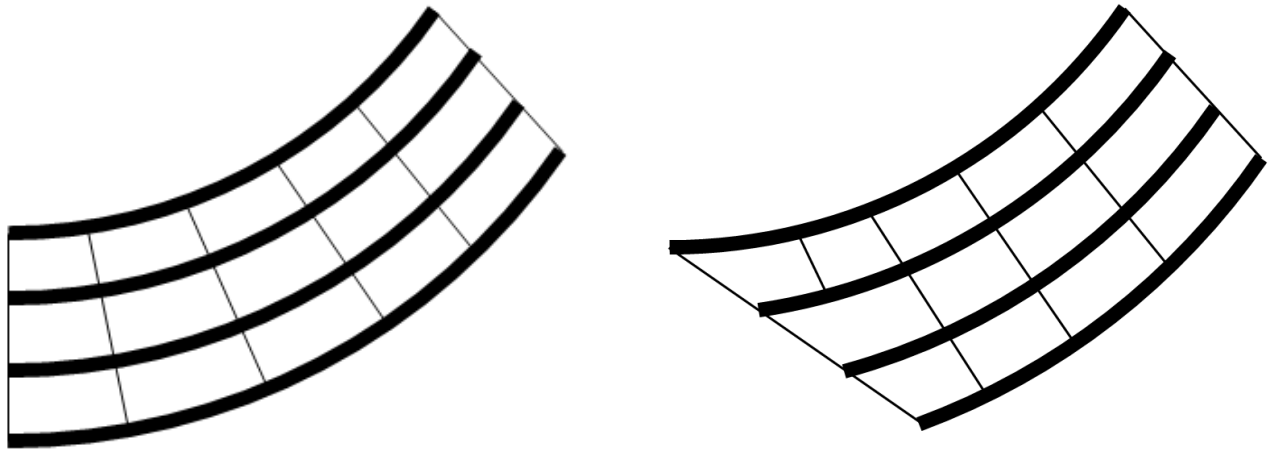


**Figure 4.6: Framing layout for straight bridges having unequal skews.**



#### 4.1.4 Horizontally Curved Bridges

In general, all cross-frames are detailed to be perpendicular to webs along the radial line for the horizontally curved bridge having radial supports as shown in Figure 4.7(a). For horizontally curved bridges with skewed support(s), intermediate cross-frames are generally arranged along the radial lines and the cross-frames at the skewed supports are parallel to the skew as shown in Figure 4.7(b).



(a) Curved bridge with radial supports

(b) Curved bridge with skew support

**Figure 4.7: Framing layout for curved bridges.**

#### 4.2 Detailing Methods

For straight bridges or bridges with skew less than  $20^\circ$ , cross-frames can be assumed to fit between the girders at all loading stages and therefore the detailing method is relatively unimportant for these bridges.

For horizontally curved and skewed bridges, there are different detailing methods that can be used to detail the cross-frame to fit between the connection point at a particular loading stage.

AASHTO (2012) [2] Article C6.7.2 describes two erected positions of I-girders in straight skewed and horizontally curved bridges. The girders can be erected as webs plum or webs out-of-plumb at three different loading stages. These loading stages are 1) No-load Stage 2) Steel Dead Load Stage, and 3) Total Dead Load Stage.

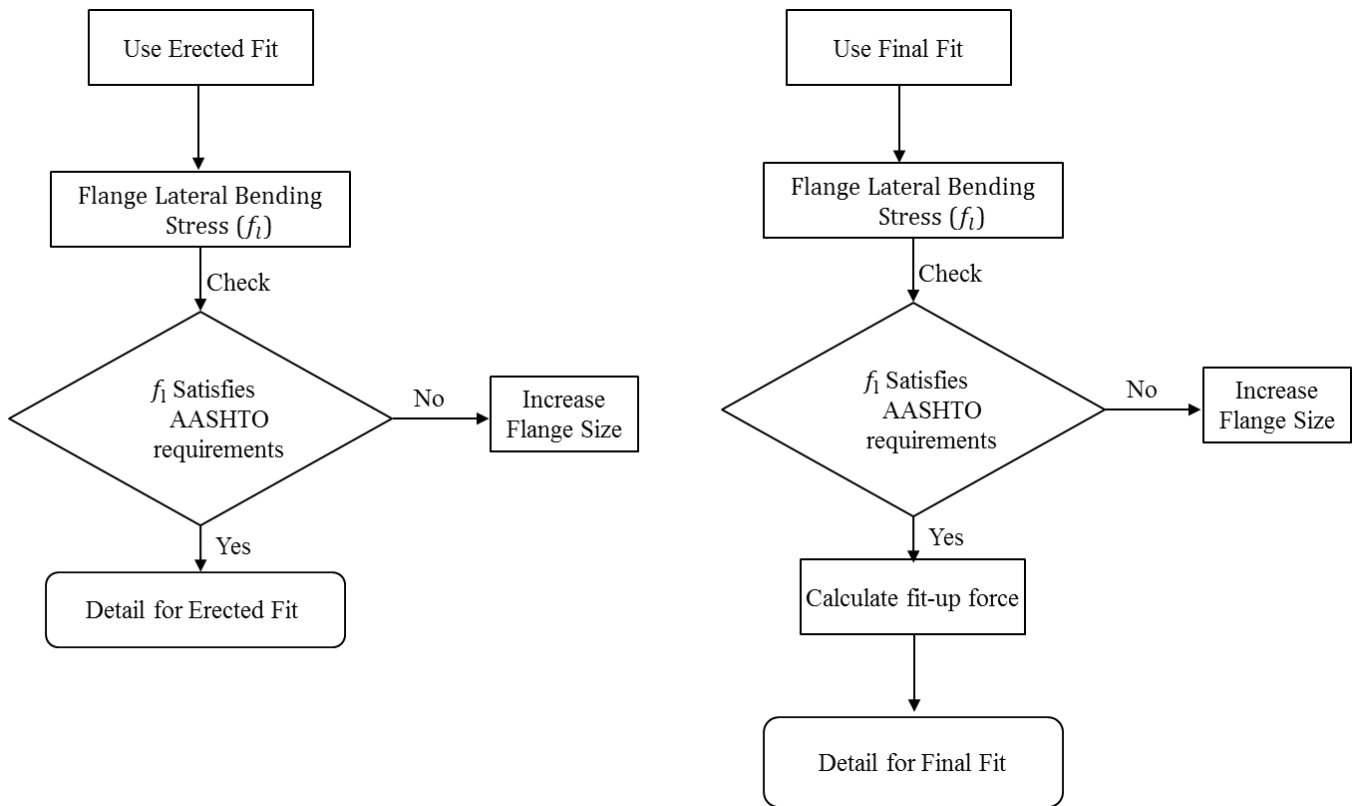
#### 4.2.1 Straight Bridges with Skew < 20°

The detailing methods for skewed bridges are discussed in detail in the final report of the companion project on framing of straight skewed I-girder bridges. The flowchart in Figure 4.8 summarizes our recommendations for selecting the detailing method.

The selection of the detailing method depends on many factors, and the final choice may be influenced by several factors, such as, local practices and owner, designer, fabricator and erector preferences. However, a flow chart is developed for each detailing method, as shown in Figure 4.8, to facilitate the selection of the detailing method.

The flange lateral bending stress,  $f_l$ , needs to be checked for both Final Fit and Erected Fit detailing methods to satisfy the AASHTO bridge design requirements. For the Final Fit detailing method,  $f_l$  at the SDL stage comes from lack-of-fit and wind load. For the Erected Fit detailing method,  $f_l$  at the TDL stage comes from the lack-of-fit and knee braces. AASHTO LRFD Bridge Design Specifications should be used to check the level of flange lateral bending stresses,  $f_l$ . There may be a need to increase the flange sizes, which may dictate the choice of detailing method.

In the Final-Fit method, the additional structural response that needs to be checked is the fit-up forces required for fitting the cross-frames between the adjacent girders during erection. The knowledge of fit-up forces will allow the erector to assess the need for having special equipment to fit the cross-frames between the adjacent girders.



**Figure 4.8: Flow chart to guide designer to deal with skew bridges**

#### 4.2.2 Horizontally Curved Bridges

Preliminary analyses of a curved bridge indicate that cross-frames in curved bridges can be detailed to fit between the girders at the No-load (NL) stage only. The cross-frames in the curved bridges cannot be detailed to fit at Steel Dead Load (SDL) stage or Total Dead Load (TDL) stage due to following reasons

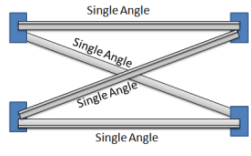
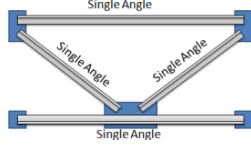
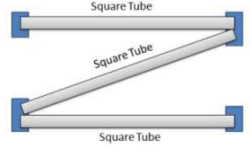
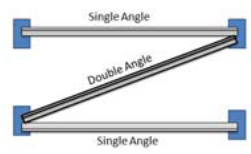
- Isolated curved girders without cross-frames attached statically unstable compared to isolated straight girders that do not have a static instability.
- For detailing the cross-frame for SDLF or TDLF, line girder analyses cambers are required. For a curved girder, an isolated or a line girder analysis cannot be done because of the static instability of the girder.

It is important to note that both straight and curved girders have buckling instabilities in the absence of lateral support (cross-frames). However this buckling instability is entirely a different phenomenon and cannot be considered in a static analysis.

### 4.3 Cross-frame Configuration

Recent research at University of Texas Austin [34] has evaluated the stiffness of different cross-frame configurations. These configurations include both traditional cross-frames, such as, single angle X-frames and the single angle K-frames, and newly proposed cross-frame configurations, such as, single angle Z-frame and Z-frame comprised of tubular members. The stiffness obtained from experimental tests and different finite element models in the study [34] for the cross-frame configurations is shown in Table 4.1. As indicated in Table 4.1 there is large difference between the stiffness obtained from FEM using truss elements and experiments for the single angle K-frame and X-frame. This difference is due to eccentricity of the single angles to their connection as pointed out in the previous studies. It is important to take into account this eccentricity as less stiff cross-frames attract relatively less cross-frame forces. The effect of the eccentricity can be observed by comparing the stiffness for the tubular members to the other three systems. The experimental results agree very well with the FEM using truss and shell element models for the case of the cross-frame comprised of tubular members. The tubular members have concentric connections. The other cross-frames had single angles and as a result there is a significant difference in the experimental results and the results using the FEM truss model. Although the shell element models work well in these cases, such a model is not practical from a design perspective, even if a 3D finite element model was used for the girder system. The researchers developed modifications that can be used for the truss configuration. These modifications should be applied to cross-frames modeled in 3D FEM models, as well as the 2D-grid models discussed earlier. When single angle(s) are used in a cross frame, truss element models overestimate the stiffness of the cross frames. The modification factor or the stiffness reduction factor (R-value) was found to be between 0.55 and 0.65. Detailed expression for calculating stiffness reduction fraction is given in literature [34].

**Table 4.1: Stiffness of different cross-frame configuration**

Cross-Frame Configuration		Member Sizes	Torsional of cross-frames (kip-in/rad)		
			Experimental	FEM Truss	FEM shell
Single Angle	X-Frame 	L4x4x3/8	872,000	1,572,000	867,000
Single Angle	K-Frame 	L4x4x3/8	760,000	1,180,000	781,000
Square Tube	Z-Frame 	HSS5x5x3/16	658,000	647,000	657,000
Double angle	Z-frame 	2L4x4x3/8	597,000	905,000	616,000

However if the cross-frames are designed to meet the stability requirements, the required braces stiffness is better provided by concentric cross-frame members such as, double angles, WT sections, channel section, and tubular sections.

The study [34] also evaluate the efficiency of different cross-frame configuration by comparing weight of the different cross-frame configuration for same value of cross-frame stiffness. It has been concluded that K-frame with concentric members are most efficient in providing the required stiffness. However, as mentioned in the study, the cost of fabrication can have a significant effect in determining the efficiency of cross-frame configuration and is not considered in the study [34].

Regarding the cross-frame configuration, FDOT structure design guidelines [30] section 5.7.A. states, “Design cross-frames and diaphragms (cross-frames at piers and abutments) with bolted connections at transverse and bearing stiffener locations and connected directly to stiffeners without the use of connection plates whenever possible. Generally, a "K-frame" detailed to eliminate variation from one cross-frame to another is the most economical arrangement and should be used. For straight bridges with a constant cross-section, parallel girders, and a girder-spacing-to-girder-depth ratio less than two,

an "X-frame" design is generally the most economical and must be considered." However, this section is not applicable to non-traditional projects.

### 4.3.1 Lean-on Bracing

The lean-on bracing system is developed by eliminating the diagonal cross-frame members from a traditional bracing system. In traditional bracing layouts for steel bridges, a bracing line typically has a full line of cross-frames across the bridge. The cross-frames are typically comprised of two struts and two diagonal members. In a lean-on system, full cross-frames are positioned in some of the bays within a bracing line while select cross-frames are replaced with systems that only have top and bottom struts. Such a system is shown in Figure 4.9. In the lean-on bracing system the girders attached to cross-frames with only top and bottom chord "lean" on the girders attached with full cross-frames. Elimination of diagonal members from the cross-frames results in the reduction of cross-frame forces due to differential deflection in skew bridges. A potential framing plan of a skew bridge using lean-on bracing system is shown in Figure 4.10. The cross-frames marked with X have full cross-frames while other cross-frames have only top and bottom chord members. The full cross-frames are arranged along the longer diagonal of skew bridge, between the acute corners, instead of the shorter diagonal, between the obtuse corner, that has large stiffness. It is important to have a few intermediate within at least every bay so that differential displacement of the girder is controlled. The detailed design of cross-frames is provided elsewhere [34].

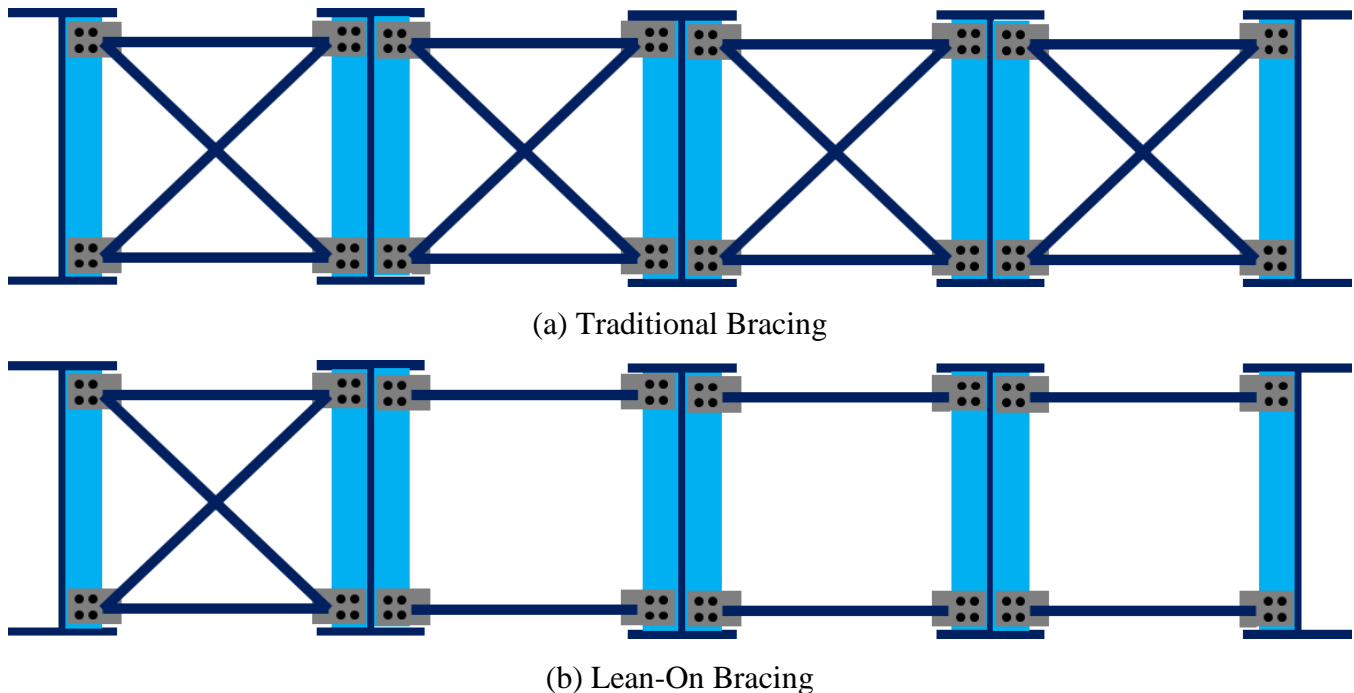
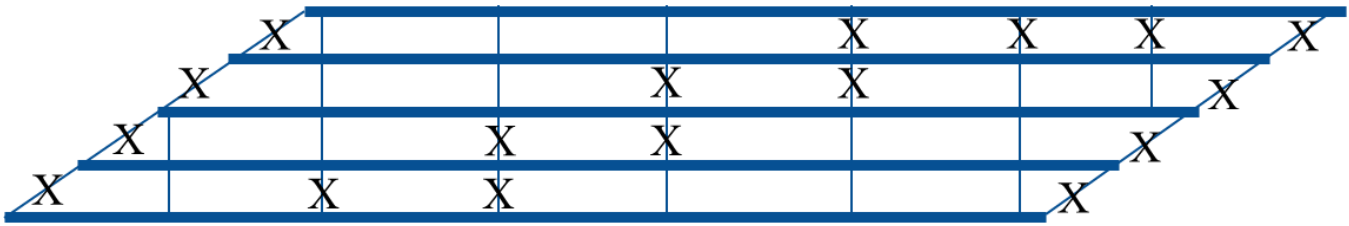


Figure 4.9: Traditional and lean-on bracing line.



**Figure 4.10: A skew bridge with lean-on bracing system**

The lean-on bracing system was implemented in three skewed bridges in Lubbock, Texas. One of the bridges was the 19<sup>th</sup> Street Bridge in Lubbock, Texas (shown in Figure 4.11). The bridge is two spans continuous with 60° skew at supports consisting of six girders that are 300 ft. long and 54 inches deep. The bridge was instrumented to get the cross-frame forces, deflection and layovers during deck casting. The instrumented cross-frame had 14.5 kips tension and 2.7 kip compression during deck casting. Due to use of stiff bearing pads in the bridge, field measured rotation was less than predicted by the ANSYS 3D model that assumed flexible supports. The maximum measured rotation was around 0.51°.



**Figure 4.11: Lean-on bracing system in 19<sup>th</sup> Street Bridge**

Lean-on bracing might reduce fabrication costs due to fewer bracing members. It might also provide advantages in maintenance over the life of the bridges due to fewer cross-frames to inspect. The most significant advantage of using lean-on cross-frame concepts in skewed bridges is the reduction in cross-frame forces under truck traffic in the completed bridge, compared to cross-frame force in a traditional cross-frame layout.

Lean-on cross-frame configuration is not available in most the commercial 2D-grid analysis software. There are no studies on the effect of lean-on bracing on the redundancy bridge. Using lean-on bracing is not a well-established common practice in steel bridge. Lean-on bracing is designed based on stability; however AASHTO LRFD code does not include the design of braces based on stability.



## 4.4 Design Approaches for Sizing Cross-Frame Members

Once, the framing layout, the detailing method and the cross-frame configuration are finalized, the cross-frame members can be sized using different design approaches. These approaches include following

- Design of braces to meet the AASHTO LRFD Specification requirements
- Design of braces to meet the AISC requirements

## 4.5 Design of Brace to Meet AASHTO LRFD Specification

AASHTO section 6.7.4.1 requires the cross-frames and diaphragms to be investigated for transfer of lateral wind loads, stability of top flange in compression, flange lateral bending, and distribution of live loads.

### 4.5.1 Straight Bridges with Skew < 20°

For straight non-skewed bridges, the proportioning of the cross-frame or diaphragm components traditionally has been accomplished by various simple rules of thumb, and by the use of very basic analysis models to determine the force demands. For instance, the AASHTO LRFD Specifications (2012) require:

- A minimum thickness of 0.3125 inches (5/16 inches) on all steel components with the exception of the web thickness of rolled beams or channels and closed ribs of orthotropic decks (Article 6.7.3).
- A maximum slenderness ratio of  $\ell/r = 140$  for primary tension members subjected to stress reversals,  $\ell/r = 200$  for primary tension members not subjected to stress reversals, and  $\ell/r = 240$  for secondary members (Article 6.8.4).
- A maximum slenderness ratio of  $K\ell/r = 140$  for secondary members loaded in compression (Article 6.9.3), and a maximum slenderness ratio of  $K\ell/r = 120$  for primary members loaded in compression (Article 6.9.3). AASHTO Article 4.6.2.5 indicates that, in the absence of a more refined analysis,  $K$  should be taken as 1.0 for single angles (largely because AASHTO now provides a separate “equivalent”  $K\ell/r$  for design of single angles), regardless of the end connection, but otherwise,  $K = 0.75$  may be used for members with bolted or welded end connections at both ends.
- Diaphragms and cross-frames should be as deep as practicable, but as a minimum should be at least 0.5 of the beam depth for rolled beams and 0.75 of the girder depth for plate girders (Article 6.7.4.2).

AASHTO LRFD Specifications also states, “At a minimum, diaphragms and cross-frames shall be designed to transfer wind loads according to the provisions of Article 4.6.2.7 and shall meet all applicable slenderness requirements in Article 6.8.4 and Article 6.9.3.” AASHTO Article 6.7.4.1 goes on to state, “If permanent cross-frames or diaphragms are included in the structural model used to determine force effects, they shall be designed for all applicable limit states for the calculated force effects.”

In Florida cross-frames are considered permanent for steel I-girder bridges regardless of bridge geometry (straight non-skewed, straight skewed, or curved). Therefore, the cross-frames need to be designed for all applicable limit states.

#### **4.5.2 Straight Bridges with Skew $\geq 20^\circ$**

The AASHTO LRFD Bridge Specification does not recognize cross-frames as primary members in both straight non-skewed bridges as well as in straight skewed bridges. Therefore, cross-frames in the skew bridges need to satisfy the same requirements as discussed above for the non-skewed bridges.

#### **4.5.3 Horizontally Curved Bridges**

For horizontally curved I-girder bridges, the AASHTO LRFD Specifications clearly recognize additional important effects:

- Diaphragm and cross-frame members in horizontally curved bridges shall be considered to be primary members (Article 6.7.4.1).

Further Article 6.7.4.2 specifies the spacing requirement for intermediate cross-frame in horizontally curved I-girder bridges as follows.

$$L_b \leq L_r \leq \frac{R}{10} \tag{24}$$

Where:

$L_r$  = limiting unbraced length determined from Eq. 6.10.8.2.3-5 (ft)

$R$  = minimum girder radius within the panel

$L_b$  = Spacing of intermediate cross-frames always less than 30 ft.

The following steps can be followed to design cross-frames in a curved bridge:

- Step 1. Select a framing plan
- Step 2. Select the cross-frame diaphragm configuration
- Step 3. Select a cross-frame member satisfying AASHTO minimum thickness and slenderness ratio requirements
- Step 4. Select cross-frame spacing satisfying the spacing requirement in section AASHTO (2012) section 6.7.4.2
- Step 5. Calculated lateral load from the knee brace and wind load (AASHTO section 4.6.2.7)
- Step 6. Use following load combinations to apply vertical and lateral load on girders to evaluate maximum cross-frame forces. Improved 2D-grid analysis can be used to carry out the structural analysis.
  - a.  $1.25(DC+DW)+1.5(CEL+CLL)$
  - b.  $1.25(DC+DW)+1.5(CEL)+1.25(WS)$

The load combination 'b' is conservative since WS is for 75 year life of the bridge.

- Step 7. Calculate the maximum tensile and compressive forces in the cross-frame
- Step 8. Check the compression capacity (AASHTO section 6.9.4.1) and tension of capacity (AASHTO section 6.8.2) of cross-frame members.

Detailed example of sizing the cross-frames for a horizontally curved bridge is provided in the appendix D.

#### **4.6 Design of Brace to Meet AISC Requirements**

AISC [35] Appendix article A6.3 on beam bracing states, “*Beams and trusses shall be restrained against rotation about their longitudinal axis at points of support. When a braced point is assumed in the design between points of support, lateral bracing, torsional bracing, or a combination of the two shall be provided to prevent the relative displacement of the top and bottom flanges (i.e., to prevent twist).*”

The required strength for nodal torsional bracing is given by the following equation:

$$M_{rb} = \frac{0.024 M_r L}{n C_b L_b} \quad (25)$$

The required stiffness of the brace is

$$\beta_{Tb} = \frac{\beta_T}{\left(1 - \frac{\beta_T}{\beta_{sec}}\right)} \quad (26)$$

Where,

$$\beta_T = \frac{1}{\phi} \left( \frac{2.4 L M_r^2}{n E I_y C_b^2} \right) \text{ (LRFD)} \quad (27)$$

$C_b$  = modification factor defined in Chapter F

$E$  = modulus of elasticity of steel = 29,000 ksi

$I_y$  = out-of-plane moment of inertia, in.<sup>4</sup>

$L$  = length of span, in.

$n$  = number of nodal braced points within the span

$\beta_T$  = overall brace system stiffness, kip-in./rad

$\beta_{sec}$  = web distortional stiffness, including the effect of web transverse stiffeners, if any, kip-in./rad

$M_r$  = required flexural strength using LRFD load combinations, kip-in.

Further the commentary of AISC specification on beam torsional bracing states, “A web stiffener at the brace point reduces cross-sectional distortion and improves the effectiveness of a torsional brace. When a cross-frame is attached near both flanges or a diaphragm is approximately the same depth as the girder, then web distortion will be insignificant so  $\beta_{sec}$  equals infinity.” The stiffeners are generally used in all I-girder bridges. Therefore, the required torsional stiffness is equal to brace stiffness as per equation A-6-10.

$$C_b = \frac{12.5M_{max}}{2.5M_{max} + 3M_A + 4M_B + 3M_C}$$

(28)

Where

$M_{max}$  = absolute value of maximum moment in the unbraced segment, kip-in.

$M_A$  = absolute value of moment at quarter point of the unbraced segment, kip-in.

$M_B$  = absolute value of moment at centerline of the unbraced segment, kip-in.

$M_C$  = absolute value of moment at three-quarter point of the unbraced segment, kip-in.

- Step 1. Select a framing plan
- Step 2. Select the cross-frame diaphragm configuration
- Step 3. Calculate the required flexural strength ( $M_r$ ) using the following LRFD load combinations.
- Step 4. Calculate the required brace stiffness using Equation A-6-10
- Step 5. Size the brace members to meet the stiffness requirement

## 5 Recommendations

### 5.1 Detailing Method

#### 5.1.1 Straight Bridges with Skew $\geq 20^\circ$

Two detailing methods, erected fit and final fit, are recommended for detailing the cross-frames for straight skewed bridges having a skew angle greater than  $20^\circ$ . It is recommended to use the flow chart shown in Figure 4.8 to facilitate the selection of detailing method and carrying out necessary design checks.

#### 5.1.2 Horizontally Curved Bridges

It is recommended to use the No-load Fit detailing method to detail the cross-frames for horizontally curved bridges. This is because of the inherent static instability and excessive twisting of isolated girders (not attached together with cross-frames) makes it difficult to find a dead load condition in which cross-frames fit between their connections to girders.

### 5.2 Methods of Analysis

#### 5.2.1 Straight Bridges with Skew $< 20^\circ$

Approximate hand methods of analysis can be used for straight bridges with skew  $< 20^\circ$  as discussed in Chapter 2. The cross-frames are negligibly small due to skew effects. The cross-frames are sized to transfer the wind load and the lateral load from knee braces.

#### 5.2.2 Straight Bridges with Skew $\geq 20^\circ$

Performance of the 2D-grid analyses is dependent on the framing layout. The traditional 2D-grid analysis can be used to calculate the cross-frame forces with contiguous framing layout. However, the traditional 2D-grid analysis does not give good estimate of cross-frame forces for staggered framing layout. The improved 2D-grid analysis gives good estimates of cross-frame forces for contiguous framing and most of staggered framing layouts. However, the improved 2D-grid analysis tends to overestimate cross-frame forces for staggered framing layout with small stagger distance.

It is recommended to use improved 2D-grid analysis because it gives good estimate of cross-frame forces for most of the framing layouts.

Detailed procedures for calculating cross-frame forces for the erected fit and the final fit detailing methods using improved 2D-grid analysis are given in Chapter 3. Concrete dead is applied to system of cross-frames and girder. The cross-frame forces are evaluated by multiplying the relative displacement to the stiffness of the cross-frames. For the final fit detailing method cross-frame forces at the steel dead load stage can be evaluated by reversing the sign of cross-frame forces evaluated for erected fit detailing at steel dead load stage.

When 3D FEM analysis method is required for evaluating cross-frame force due to lack-of-fit, it is recommended using cross-frames that have employed element birth and death techniques in lieu of using initial strains for simulating lack-of-fit. The element birth and death approach is simpler compared to using initial strain and evaluate cross-frame forces with same accuracy.

### **5.2.3 Horizontally Curved Bridges**

The 2D-grid analysis program developed by the authors is not applied to the curved bridges. The recommendation of using improved 2D-grid analysis for curved bridges is based on the results presented in NCHRP 725, G13.1 and G13.2.

There is no need for developing procedures for using improved 2D-grid analysis for the dead load detailing method because it is recommended to use only No-load Fit detailing method for horizontally curved bridge.

## **5.3 Calculation of Camber**

The calculation of camber depends on the detailing method used for the cross-frames. The following sections provide the recommendations for calculating cambers for skewed and curved bridges.

### **5.3.1 Straight Bridges with Skew $\geq 20^\circ$**

For the erected fit detailing method, steel dead load cambers should be estimated by line girder analysis and the concrete dead load cambers should be calculated by 2D-grid analysis or 3D FEM analysis modeling all the girders and cross-frames connected together. For the final fit detailing method both steel dead load and concrete dead load cambers need to be calculated by line girder analysis as shown in Table 5.1.

**Table 5.1: Method of calculation of camber for different detailing methods**

Detailing Method	Method of calculation of camber for	
	Steel dead load	Concrete dead load
Erected fit	Line girder analysis	2D-grid analysis
Final fit	Line girder analysis	Line girder analysis

### **5.3.2 Horizontally Curved Bridges**

It is recommended to estimate both steel dead load and concrete dead load cambers by improved 2D-grid analyses for horizontally curved bridges. This is because of the fact that horizontally curved bridges can be detailed only using the no-load fit detailing method.



## References

- [1] AASHTO/NSBA Steel Bridge Collaboration. (2011). *G 13.1 Guidelines for steel girder bridge analysis*. AASHTO/NSBA Steel Bridge Collaboration.
- [2] AASHTO. (2012). *AASHTO LRFD Bridge Design Specifications*. Washington, DC: American Association of State Highway and Transportation Officials.
- [3] Mertz, D. R. (2001). *Designers' Guide to Cross-Frame Diaphragms. Prepared for the American Iron and Steel Institute* .
- [4] Helwig, T., & Yura, J. (2012). Bracing System Design. In FHWA, *Steel Bridge Design Handbook: Bracing System Design*. Washington, D.C.: Federal Highway Administration.
- [5] NHI. (2011). *Analysis and design of skewed and curved steel bridges with LRFD : reference manual*. U.S. Dept. of Transportation, Federal Highway Administration, National Highway Institute.
- [6] White, D. W., Coletti, D., Chavel, B. W., Sanchez, A., Ozgur, C., Chong, J. M., et al. (2012). *NCHRP 725: Guidelines for Analysis Methods and Construction Engineering of Curved and Skewed Steel Girder Bridges*. NCHRP and NSBA.
- [7] Taylor, A. C., & Ojalvo, M. (1966). Torsional Restraint of Lateral Buckling. *Journal of the Structural Division, ASCE 92 (ST2)* , 115–12.
- [8] Yura, J., Phillips, B., Raju, S., & Webb, S. (1992). *Bracing of Steel Beams in Bridges*. Austin, TX: Center for Transportation Research, Univ. of Texas at Austin.
- [9] Yura, J. (1993). “Fundamentals of Beam Bracing,” Is Your Structure Suitably Braced? *1993 Conference, Milwaukee, Wisconsin* (pp. 1-40). Bethlehem, PA: Structural Stability Research Council.
- [10] Yura, J. (2001). Fundamentals of Beam Bracing. *Engineering Journal, AISC, 38(1)* , 11-26.
- [11] Bishop, C., Sharma, A., Kim, Y., & White, D. (2010). *Flange Bracing Requirements for Stability of Metal Building Systems*. Atlanta, GA: School of Civil and Environmental Engineering, Georgia Institute of Technology.
- [12] NHI. (2007). *Load and Resistance Factor Design (LRFD) for Highway Bridge Superstructures*. US Department of Transportation, FHWA.

- [13] Richardson, Gordon and Associates. (1963). *Analysis and Design of Horizontally Curved Steel Bridge Girders*. United States Steel Structural Report.
- [14] Grubb, M. (1984). Horizontally Curved I-Girder Bridge Analysis: V-Load Method. *Transportation Research Record 289* , 26-36.
- [15] Poellot, W. (1987). Computer-Aided Design of Horizontally Curved Girders by the V-Load Method. *Engineering Journal, AISC, Vol. 24, No. 1* , 42–50.
- [16] BridgeTech, Inc., Tennessee Technological University, & Mertz, D. (2007). *NCHRP Report 592: Simplified Live Load Distribution Factor Equations*. Washington, DC: Transportation Research Board.
- [17] Womack, K., & Crookston, B. (2003). *Method of Analysis Comparison Study for a Curved, Steel Girder Bridge*. West Salt Lake City, Utah: Utah Department of Transportation Research Division.
- [18] The BEST Center . (2011). DESCUS I and II Design and Analysis of Curved I-Girder Bridge System.
- [19] MDX Software. (2011). MDX Version 6 Curved & Straight Steel Bridge Design and .
- [20] LARSA, Inc. (2010). LARSA 4D Advanced software for the analysis and design of bridges and structures.
- [21] Ahmed, M., & Weisberger, F. (1996). Torsion Constant for Matrix Analysis of Structures Including Warping Effect. *International Journal of Solids and Structures, Elsevier 33(3)* , 361-374.
- [22] Chang, C.-J., & White, D. W. (2008). An assessment of modeling strategies for composite curved steel I-girder bridges. *Engineering Structures, Volume 30, Issue 11* , 2991–3002.
- [23] Chang, C. (2006). Construction Simulation of Curved Steel I-Girder Bridges. *PhD thesis* . Georgia Institute of Technology, Atlanta, GA.
- [24] Simulia. (2010). Abaqus Software.
- [25] Chavel, B. W., & Earls, C. J. (2006). Construction of a horizontally curved steel I-girder bridge: Inconsistent detailing. *Journal of Bridge Engineering, Vol. 11, No. 1* , 91-98.
- [26] Grunauer, T. A. (2011). Influence of bracing systems on the behaviour of curved and skewed steel I-Girder Bridges during construction. *PhD thesis* . Georgia Institute of Technology.

- [27] Ozgur, C. (2011). Influence of Cross frame detailing on curved and skewed steel I-Girder Bridges. *PhD Thesis* . Georgia Institute of Technology.
- [28] ANSYS. (2009). ANSYS Release 12.1 UP20091102. *Analysis Software* . Copyright 2009 SAS IP, ANSYS Inc.
- [29] Gull, J. H., Azizinamini, A., White, D. W., & Helwig, T. A. (2013). Framing of Straight Skewed Steel I-Girder Bridges: Comparison of Erected Fit and Final Fit detailing methods. *AISC Engineering Journal* , Submitted.
- [30] FDOT. (2013). *Structure Design Guidelines*. Tallahassee: Florida Department of Transportation.
- [31] AASHTO. (2007). *AASHTO LRFD Bridge Design Specifications*. Washington, DC: AASHTO.
- [32] AWS, & AASHTO. (2010). *Bridge Welding Code (Joint Publication with AASHTO)*. American Welding Society .
- [33] Quadrato, C., Engelhardt, M., Battistini, A., W., W., Helwig, T. A., & and Frank, K. (2010). *Cross-Frame and Diaphragm Layout and Connection Details*. Austin, TX: The University of Texas at Austin.
- [34] Wang, W. (2013). A Study of Stiffness of Steel Bridge Cross Frames. *Doctoral Dissertation* . The University of Texas at Austin.
- [35] AISC. (2010). *Specification for Structural Steel Buildings*. Chicago, Illinois: American Institute of Steel Construction.
- [36] Elhelbawey, M., & Fu, C. (1998). Effective Torsional Constant for Restrained Open Section. *J. Struct. Eng.*, *124(11)* , 1363–1365.

## **Appendix A: DOT Survey**

The main objective of this project is to develop a set of recommendations and procedures and instructions to address analysis, design and construction issues related to cross-frames and diaphragms which could lead to uniform design of cross-frames. One of the objectives of this project is conduct a survey is to gather information on design, construction, fabrication for cross-frames and diaphragms in (a) Straight I-Girder Bridges, (b) I-Girder Bridges with Skewed Supports, and (c) Curved I-Girder Bridges.

Summary of survey sent to various DOTs, attempting to collect the available information useful for this project is presented here. The survey also helped to notify the other DOTs about the work at FDOT.

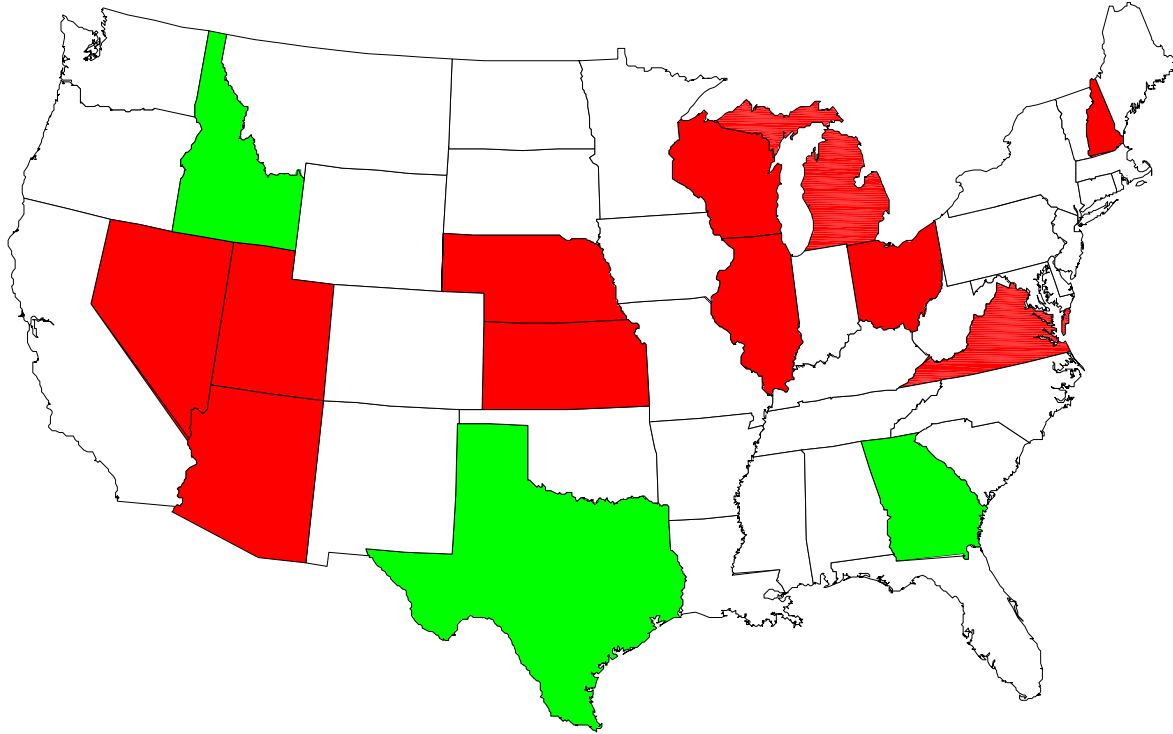
The major emphasis of the questions asked in the survey is to

- a) identify the various methods used by DOTs to design and construct cross-frames and diaphragms, especially for skewed and curved girder bridges,
- b) locate any possible field problems and solutions associated with cross-frames and diaphragms and
- c) obtain research data, published or unpublished

15 states responded to the survey questionnaire. Responses of the different states are summarized as follows

### **A.1 States Having Guidelines for Calculating Forces in Cross-frames**

Only three states have guidelines for calculating the forces in the cross-frames.



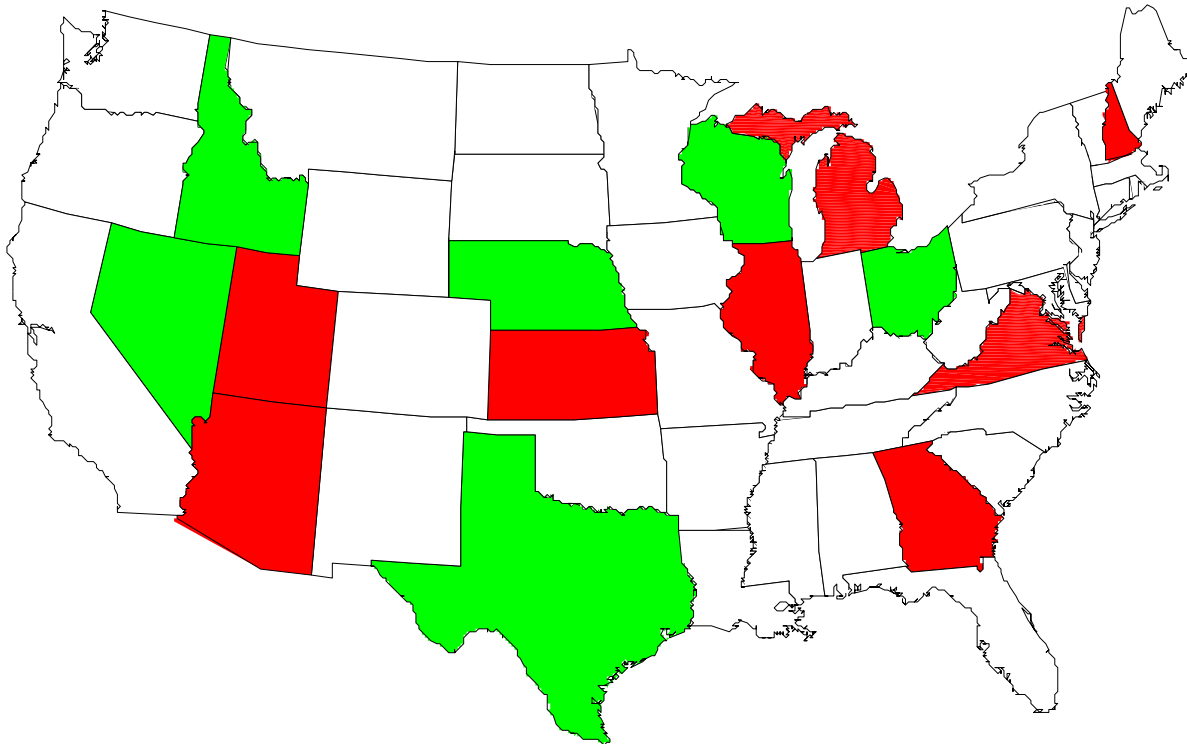
**Figure A.1: States having guidelines for calculating forces in cross-frames (Green = Yes, Red = No, White = Not participated)**

\*Alaska also responded to the survey questionnaire

**Table A.1: Summary of responses to question 1 of the survey**

State	Response to question	Explanation
'Alaska'	No	
'Georgia'	Yes	<p>“We generally just size diaphragms based on the overall depth of the girders. This is true for straight bridges and skewed bridges. For curved girders, the diaphragms are designed based on the AASHTO Specifications.”</p>
'Kansas'	No	<p>“We only require <math>L/r &lt; 140</math> and spacing <math>&lt; 25</math> ft.”</p>
'Michigan'	No	<p>“Only base cross-frame member sizes on <math>kl/r</math> ratio per section 6.9.3 of the AASHTO LRFD Design Specifications. Conservatively, the smallest radius of gyration of the two axis is used and 1.0 is used for “k” instead of the permitted 0.75 value shown in section 4.6.2.5 of AASHTO.”</p>
'Texas'	Yes	<p>“A unique cross-frame system is lean-on bracing, explored in a TxDOT-funded research project. A design method to determine cross-frame needs is provided in the report, available here: <a href="http://library.ctr.utexas.edu/pdf1/1772-1.pdf">http://library.ctr.utexas.edu/pdf1/1772-1.pdf</a>.</p> <p>We constructed at least one highly skewed bridge with the lean-on bracing described in the report.”</p>

**A.2 States Having Design, And Detailing Construction Guideline for Addressing Layover of Cross-Frame In The Case Of Straight, Curved and/or Skewed Bridges**



**Figure A.2: States having design, and detailing construction guideline for addressing layover of cross-frame in the case of straight, curved and/or skewed bridges (Green = Yes, Red = No, White = Not participated)**

\*Alaska also responded to the survey questionnaire

**Table A.2: Summary of responses to question 2 of the survey**

State	Response to question	Explanation
'Alaska'	No	
'Kansas'	No	"KDOT has always required the frames be plumb in the "No-Load" condition. The choices are plumb in with the "Girder Self Weight" Condition " No- Load" "Full- Load"."
'Nebraska'	Yes	We use V-loads analysis for curved girders. And follow AASHTO guidelines for addressing the skewed bridges. We have standard details. Please refer to our BOPP design manual on line
'Nevada'	Yes	<p>"Cross-frame layout and detailing guidelines are provided in Section 15.5.4 of the NDOT Structures Manual which can be accessed at:</p> <p><a href="http://www.nevadadot.com/About_NDOT/NDOT_Divisions/Engineering/Structures/Structures_Manual.aspx">http://www.nevadadot.com/About_NDOT/NDOT_Divisions/Engineering/Structures/Structures_Manual.aspx</a></p> <p>A revision to this section is included within the file labeled "Revision 2011-01" also located at this web address."</p>
'Ohio'	Yes	<p>"ODOT requires that the beam/girder be plumb at the time of erection (see ODOT Construction and Material Specifications, Section 513.26). ODOT provided guidance to Designers in an April 2007 seminar, limiting the amount of girder rotation to 1/8" per foot of beam height. This seminar is available for viewing at:</p> <p><a href="http://www.dot.state.oh.us/Divisions/Engineering/Structures/stadard/Pages/SkewedBridges.aspx">http://www.dot.state.oh.us/Divisions/Engineering/Structures/stadard/Pages/SkewedBridges.aspx</a></p>
'Texas'	Yes	"We erect girders plumb, detail the cross-frames to fit in the final condition (full dead load), and connect cross-frames to girders by field welding. There have been isolated cases of bolting instead of welding, but welding is the normal field connection for cross-frames. In a recent meeting of the Texas Steel Quality Council, we discussed the topic of steel detailing and cross-frame fit vs load condition. It was agreed to



		continue the above practice as no problems of significance have occurred with this method. Field welded cross-frame to girder connections still use at least one erection bolt at each corner of the cross-frame. In some instances, usually high skews, the holes for these erection bolts have been slotted to allow for differential deflection between girders. In these cases, welding the cross-frame to girder connection has been restricted until the slab has been placed”.
'Wisconsin'	Yes	“Not very detailed guidance, but some in Chapter 24 of the WisDOT Bridge Manual (see attached).”

### **A.3 Summary of Documents Referred By Different DOTs**

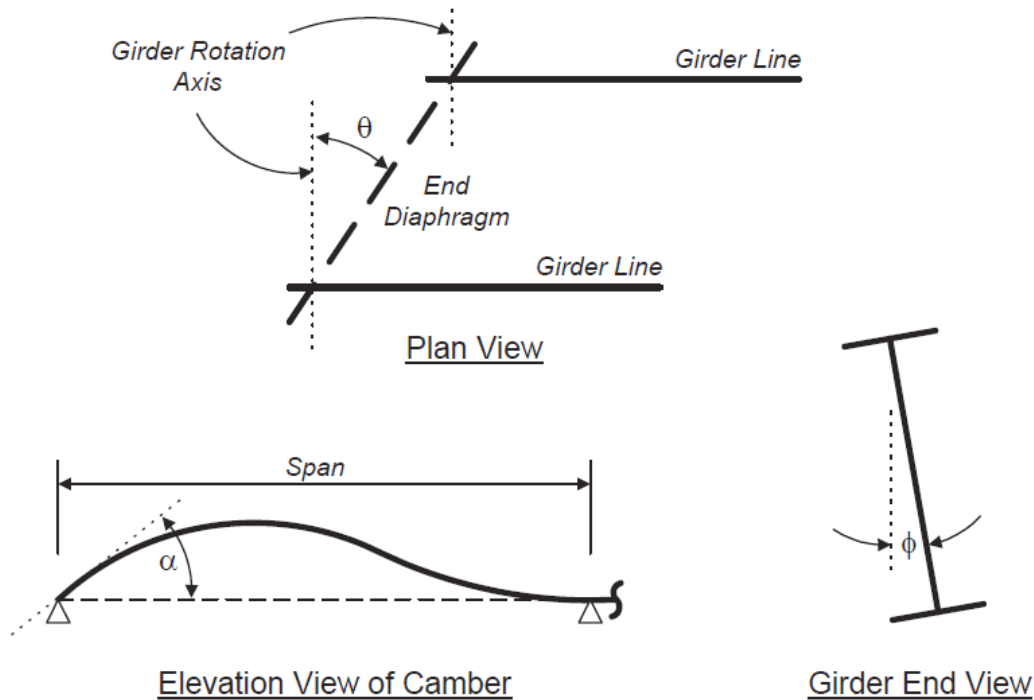
#### **A.3.1 Idaho DOT**

Idaho DOT referred to section “6. 10.3 Constructability Considerations for Steel Plate Girder Bridges” of their bridge manual [1]. This section addresses the second question in survey about detailing construction guideline for addressing layover of cross-frame in the case of straight, curved and/or skewed bridges. A brief description of this article is as follows.

Twist in the girders are described on bridges with skew supports due to different axis of rotations of the girders. As shown in the Figure A.3 each girder has its own axis of rotation that is at an offset from axis of rotation of adjacent girder. So when load is applied and ends of the girders rotate a distorting force is applied to the brace. Braces are very stiff diagonally compared to the torsional stiffness of the girders. Therefore the distortive force twists the girders out of plumb.

$$\phi = \alpha \tan(\theta)$$

where:  $\phi$  = the out-of-plumb angle  
 $\theta$  = the bridge skew angle  
 $\alpha$  = the angle of the end of the girder due to the dead load camber (other than girder self weight)



**Figure A.3: Twist in girder connected by braces in skewed support bridge**

The section 6.3.10 also describes briefly the detailing methods and Idaho Transportation Department (ITD). As written in the section and I quote here

*“While there is no way to prevent girder twisting without the complete removal of diaphragms, when and how the girders twist can be controlled by the way the girders are detailed and fabricated. If the girders and diaphragms are detailed and fabricated for the diaphragms to fit the initial position of the girders, before the bridge deck is placed, then the girders will be plumb when the erection is complete. However, after the deck is placed, the girders will be twisted permanently in their final position, the girders will not sit level on the bearings and high distortional stresses will be locked into the diaphragms and girders. The only advantage to this method is that the girders and diaphragms fit initially, making it easier for the contractor to assemble.”*

*“On the other hand, if the girders and diaphragms are detailed and fabricated for the final position then the girders will need to be twisted out of plumb initially in order to get the diaphragms installed. However, after the deck is placed, the girders will be plumb for their final permanent position with a*

*minimum amount of permanent distortional stresses in the diaphragms and girders. Standard practice for ITD is to detail diaphragms for the final position....”*

It should be noted that ITD requires both girders and cross-frames to be plumb for final position. In other words ITD requires both girders and cross-frames to be detailed for Total Dead Load Fit.

### **A.3.2 Kansas DOT**

Kansas DOT has published a report on “Cross-Frame Diaphragm Bracing of Steel Bridge Girders” in 2008 [2]. This report does not discuss the problem of layovers in skewed bridge. It describes the recent changes in bridge design like elimination of in-plane bracing, composite girder, high performance steel, and phase deck placement and impact of these changes on design and spacing of cross-frames. An example of a bridge that suffered from construction difficulties due to inadequately stiff cross-frames is also presented.

### **A.3.3 Nevada DOT**

According to Nevada DOT policies as stated in their structures manual 2008 [3] are summarized as followings

- Diaphragms are designed as primary members in curved bridge and secondary members in straight skewed bridges
- A rational analysis is required to determine cross-frame forces for bridges have exceptional skew
- End cross-frames should be placed along the centerline of bearing
- Intermediate cross-frames should be oriented perpendicular to web. For skewed bridges the stiffeners may be skewed to connect the diaphragms of cross-frames directly to the stiffeners
- Interior support diaphragms are recommended to be place along the centerline of bearing
- All the intermediate cross-frames needs to be placed perpendicular to girders
- Diaphragms for the curved girders should be oriented radially
- Cross-frames and diaphragms are typically detailed to follow the cross of the deck
- K-Frames are preferred for plate girder bridge and X-Frames are used when girder have relatively smaller spacing to depth ratio (less than 1.75)

### **A.3.4 Texas DOT**

Texas DOT has referred to a presentation by Todd Helwig of University of Texas at Austin [4]. The presentation describes three types of bracing systems

- Lean-on bracing
- Lateral bracing by Permanent Metal Deck Forms
- Trapezoidal box girder systems

Brace strength and stiffness formulas are given for lean-on bracing.

Advantages of lean-on bracing system include the reduction in number of cross-frames. The proposed bracing system is implemented to three bridges in Lubbock District. Lean-on layout required 35 intermediate cross-frames and traditional layout require 128 intermediate cross-frames.

Permanent metal deck forms can have eccentric connections due variation in flange thickness differential camber and super elevation. Different types of details are tested for PMDF. The proposed detail is implemented to the Fulton and Irvington Overpasses.

Torsional stiffness of box girders is much higher than torsional stiffness of I girders. From finite element analysis relation between the cross-frame force and length from skew support is established both for continuous flange and discontinuous flange.

### **A.3.5 Wisconsin DOT**

Wisconsin DOT has discussed different framing options available for bridges with skew supports.

#### *A.3.5.1 Adjacent Girders with Unequal Stiffness*

“However, when the relative stiffness of points on adjacent girders attached by cross-frames or diaphragms is different (for example, when the cross-frames or diaphragms are perpendicular to the girders), the design becomes more problematic. The skew affects the analysis of these types of skewed bridges by the difference in stiffness at points connected by perpendicular cross-frames.”

#### *A.3.5.2 Effect of Skew on Load Distribution*

It should be noted that dead load as well as live load is affected by skew. The specifications address the effect of skew on live load by providing correction factors to account for the effect of skew on the wheel-load distribution factors for bending moment and end support shear in the obtuse corner. There is currently no provision requiring dead load on skewed bridges to be addressed differently than for other bridges.

#### *A.3.5.3 Simple and Continuous Span*

Skewed simple spans seem to be more problematic than continuous spans with the same skew.

#### *A.3.5.4 Orientation of Cross-Frames*

“If the skew is 15 degrees or less and both supports have the same skew, it is usually desirable to skew the cross-frames or diaphragms to be parallel with the supports. This arrangement permits the cross-frames or diaphragms to be attached to the girders at points of equal stiffness, thus reducing the relative deflection between cross-frame and diaphragm ends, and thus, the restoring forces in these members. AASHTO LRFD permits parallel skews up to 20 degrees.”

#### *A.3.5.5 Staggering of Cross-Frames*

“Typically, the cross-frames or diaphragms can be staggered. This arrangement reduces the transverse stiffness because the flanges flex laterally and relieve some of the force in the cross-frames or diaphragms. There is a resultant increase in lateral bending moment in the flanges. Often, this lateral bending is not critical and the net result is a desirable reduction in cross-frame forces or diaphragm forces. Smaller cross-frame forces or diaphragm forces permit smaller cross-frame or diaphragm members and smaller, less expensive cross-frame or diaphragm connections. Alternatively, they are placed in a contiguous pattern with the cross-frames or diaphragms matched up on both sides of the interior girders, except near the bearings. This arrangement provides the greatest transverse stiffness. Thus, cross-frame forces or diaphragm forces are relatively large, and the largest amount of load possible is transferred across the bridge. This results in the largest reduction of load in the longitudinal members (that is, the girders). The bearings at oblique points receive increased load.”

#### *A.3.5.6 Refined Analysis Requirement*

“In lieu of a refined analysis, LRFD [C6.10.1] contains a suggested estimate of 10.0 ksi for the total unfactored lateral flange bending stress,  $f_l$ , due to the use of discontinuous crossframe or diaphragm lines in conjunction with a skew angle exceeding 15 degrees. It is further suggested that this value be proportioned to dead and live load in the same proportion as the unfactored major-axis dead and live load bending stresses. It is currently presumed that the same value of the flange lateral buckling,  $f_l$ , should be applied to interior and exterior girders, although the suggested value is likely to be conservative for exterior girders for the reason discussed previously. Therefore, lateral flange bending due to discontinuous cross-frame lines in conjunction with skew angles exceeding 15 degrees is best handled by a direct structural analysis of the bridge superstructure.”

## A.4 QUESTIONNAIRE

### Florida Department of Transportation Project, BDK80 977-20 Steel Plate Girder Diaphragm and Cross Bracing Loads

#### Background

This survey is being conducted as part of FDOT project: Steel Plate Girder Diaphragm and Cross Bracing Loads. The main objective of this project is to develop a set of recommendations and procedures and instructions to address analysis, design and construction issues related to cross-frames and diaphragms which could lead to uniform design of cross-frames. One of the objectives of this survey is to gather information on design, construction, fabrication for cross-frames and diaphragms in (a) Straight I-Girder Bridges, (b) I-Girder Bridges with Skewed Supports, and (c) Curved I-Girder Bridges.

We would deeply appreciate your time and efforts to provide the information for this survey. Please return the completed questionnaire via e-mail before November 15, 2011, to:

Dr. Atorod Azizinamini  
Professor and Chair  
Civil and Environmental Engineering Department  
Florida International University  
College of Engineering and Computing  
10555 West Flagler Street, EC 3677  
Miami, FL 33174  
Phone (305) 348-6875  
Fax (305) 348-2802  
Email: [atorod.azizinamini@fiu.edu](mailto:atorod.azizinamini@fiu.edu)

Please provide the name of the person completing this questionnaire or someone who may be contacted to obtain any needed follow-up information:

Name: \_\_\_\_\_

Title: \_\_\_\_\_

Agency: \_\_\_\_\_

Address: \_\_\_\_\_

City: \_\_\_\_\_ State: \_\_\_\_\_ Zip: \_\_\_\_\_

Country: \_\_\_\_\_

Phone: \_\_\_\_\_ Fax: \_\_\_\_\_

E-mail: \_\_\_\_\_

1. Do you have any guideline for calculating forces in cross-frames?

Yes

No

If yes, please give your reference.

---

---

---

---

---

---

---

---

---

---

2. Do you have any design, and detailing construction guideline for addressing layover of cross-frame in the case of straight, curved and/or skewed bridges?

Yes

No

If yes, please give your reference.

---

---

---

---

---

---

---

---

---

---

## **Appendix B: International Survey**

PI has visited Europe in August 2012 and discussed various issues related to the construction of skewed and curved I-girder bridges with bridge engineers and experts. The European specification does not have any special provisions on cross-frame force calculations, etc. They predominantly use 3-D finite element analysis for complex bridges.



## Appendix C: Analysis using MDX

As described earlier in chapter 2, the popular software packages DESCUS I and II [5] and MDX [6] both utilize these traditional 2D GA. In traditional 2D GA, torsional stiffness of the girders is not modeled correctly. Effects of incorrect torsional stiffness of girders on structural responses of skew bridges are highly dependent on the framing plan of the bridge. Traditional 2D grid analysis give reasonable estimates of all structural responses except for flange lateral bending stress for the bridges with contiguous framing. Structural responses of the bridge with staggered framing are incorrectly estimated by traditional 2D GA.

This appendix shows analysis results obtained from traditional 2D grid analysis using MDX software and the software developed by FIU as part of this project and compares these results with the results obtained from 3D FEM analysis using ANSYS software. Comparisons were made for Bridge A and Bridge B. Details of these bridges and comparison of results are given in the following sections.

### C.1 Bridge A

Bridge ‘A’ has 300 ft. long 144 inches deep girders simply supported on 70.4° skewed supports. The girders of Bridge ‘A’ are braced with X-type cross-frames containing L6 x 6 x 1 angles. The bridge uses staggered cross-frames at spacing of 22 ft. between 9 girders at 9.25 ft. c/c spacing. Framing planes and sizes of the web and flanges of the bridges studied are shown in Figure C.1.

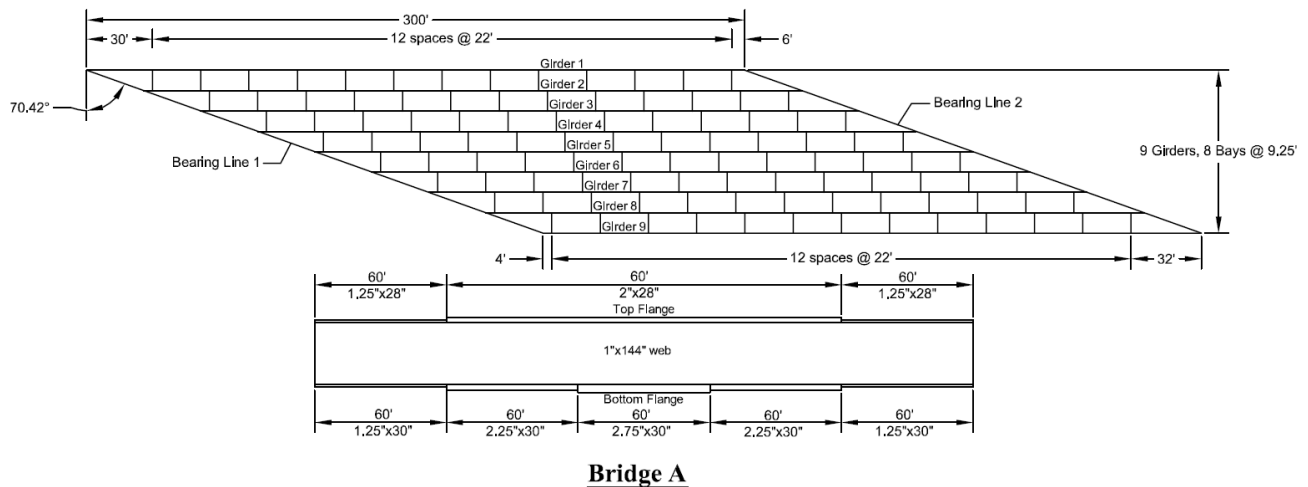
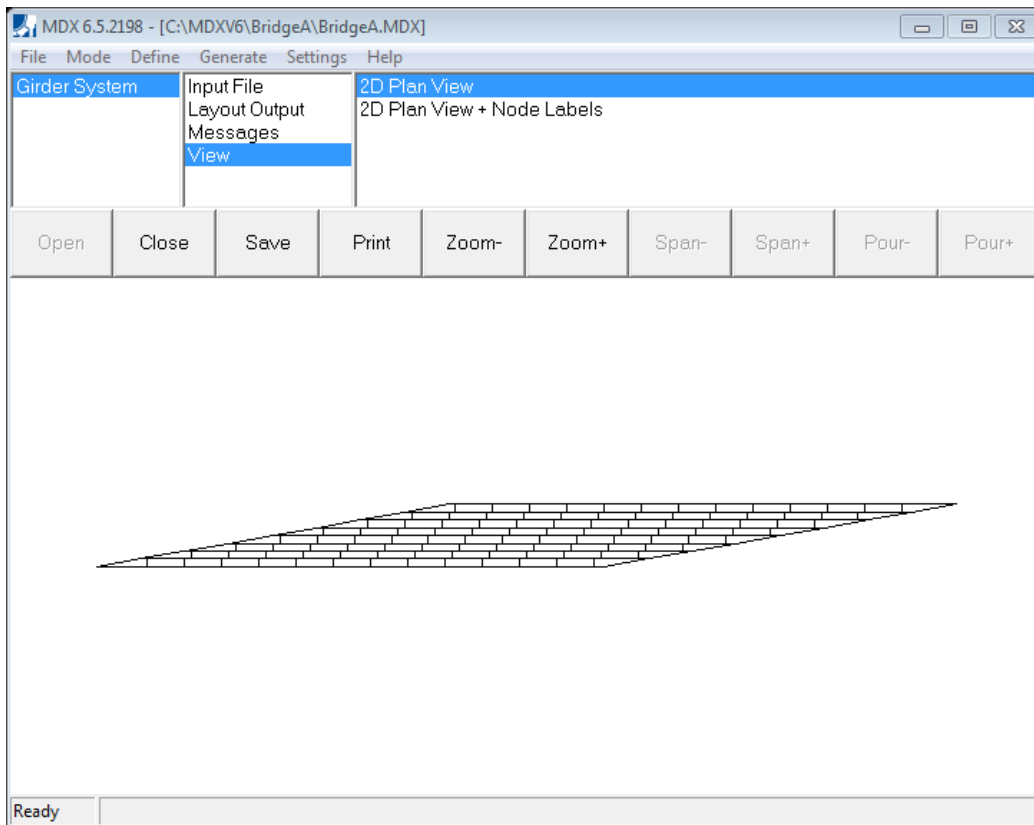


Figure C.1: Framing plans and girder sizes of the Bridge A

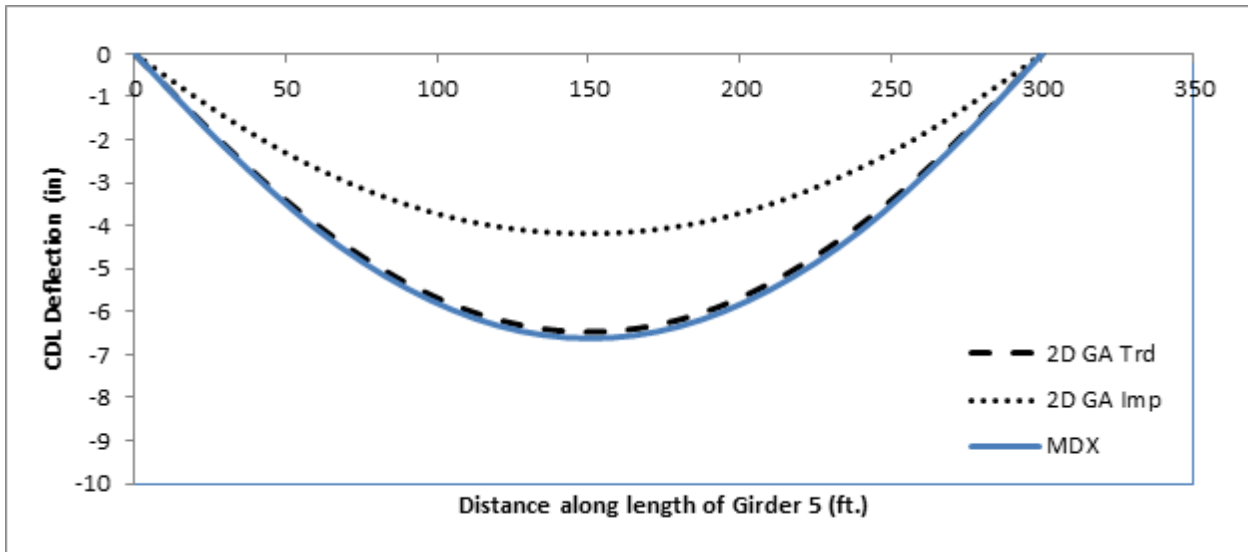


**Figure C.2: 2D Grid model of Bridge A in MDX**

The vertical deflection of Girder 5 of Bridge A due to concrete dead load (CDL) was obtained using FIU software and MDX software. The FIU software has capability of carrying out both traditional and improved 2D GA analysis, whereas, MDX software can carry out only traditional 2D grid analysis. Figure C.3 compares the vertical deflections obtained from different methods of analysis using different analysis software. Following observations can be made by inspecting the data presented in Figure C.3:

- Using FIU software, vertical deflection obtained from improved 2D grid analysis is about 2.2 inch less compared to vertical deflection obtained from traditional 2D grid analysis.
- Vertical deflection obtained from MDX software is in close agreement with the vertical deflection obtained from FIU software using traditional 2D grid analysis. This implies that MDX software uses traditional 2D GA.

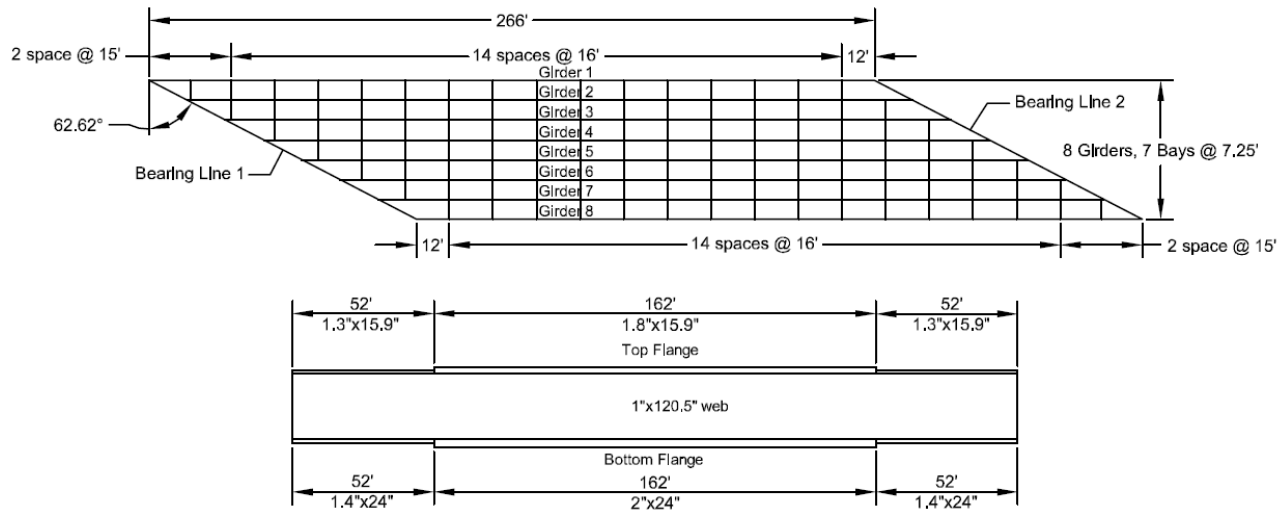
(Note: Figure C.3 and Figure C.6 use 2D GA Trd to connote traditional 2D GA carried out using FIU software, 2D GA Imp to connote improved 2D GA carried out using FIU software, and MDX to connote traditional 2D grid analysis carried out using MDX software.)



**Figure C.3: Comparison of concrete dead load vertical deflection of Girder 5 of Bridge A obtained from different methods of analysis**

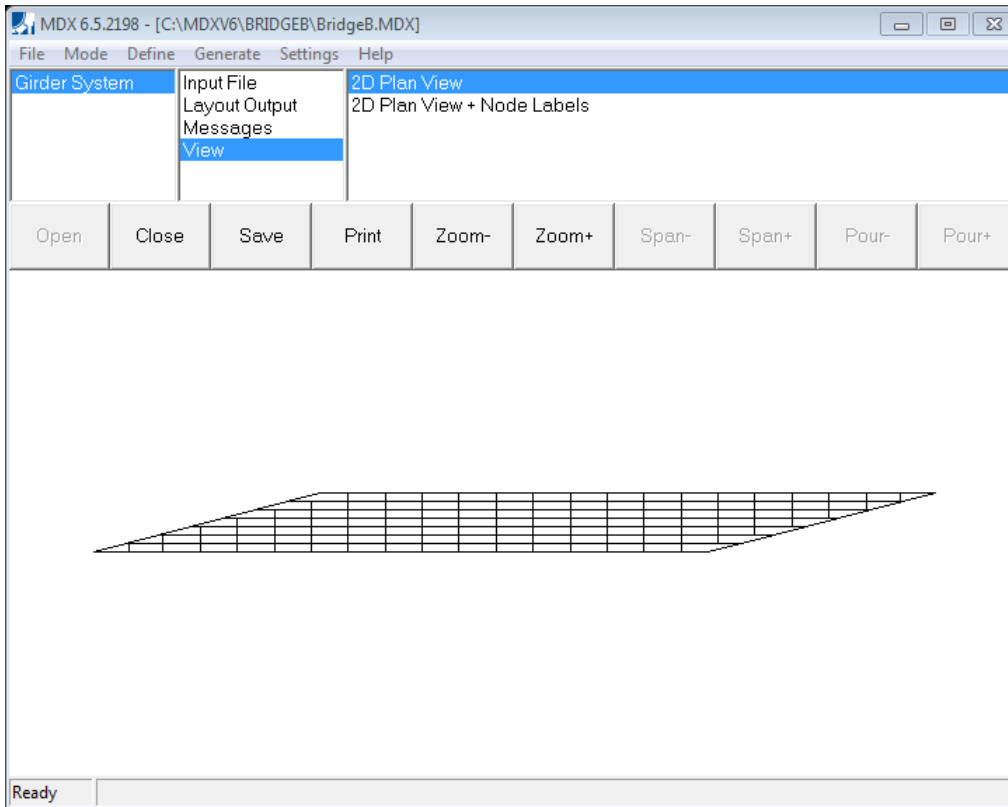
## C.2 Bridge B

Bridge ‘B’ is another highly skewed bridge, however skewed effect in Bridge ‘B’ are smaller compared to Bridge ‘A’. Bridge ‘B’ has 266 ft. long 120.5 inches deep girders simply supported on 62.6° skewed supports. The girders of the Bridge ‘B’ are braced with X-type cross-frames containing L6 x 6 x 1/2 angles. The bridge uses cross-frames at spacing of 16 ft. between 8 girders@7.26 ft. c/c spacing. Framing planes and sizes of the web and flanges of the bridges studied are shown in Figure C.4.



**Bridge B**

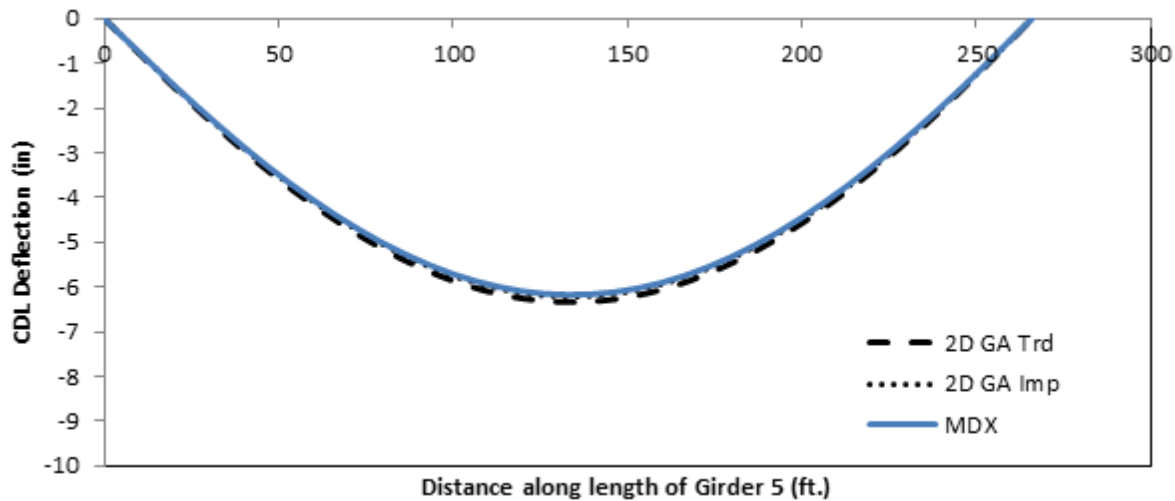
**Figure C.4: Framing plans and girder sizes of the Bridge B**



**Figure C.5: 2D Grid model of Bridge B in MDX**

Bridge B uses continuous framing for which both traditional and improved 2D grid analysis calculate similar responses except for flange lateral bending stress. This is discussed in detail in Chapter 3 of the report. Therefore, it is expected to obtain similar vertical deflection of girders of Bridge B from different methods of analysis using different software.

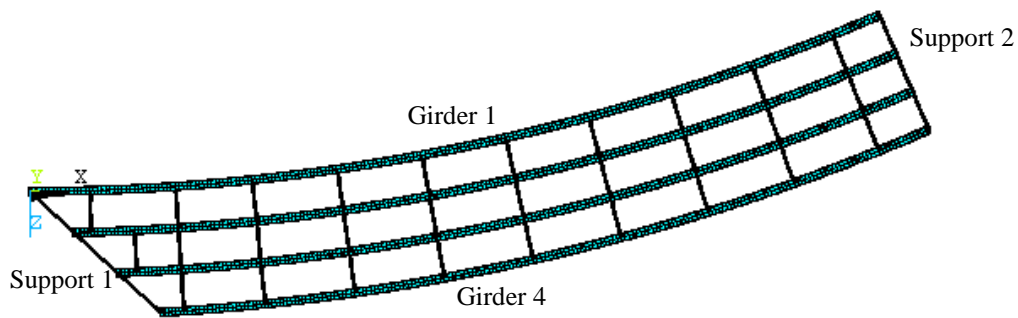
The vertical deflection of Girder 5 of Bridge B due to concrete dead load (CDL) was obtained using FIU software and MDX software. The FIU software has capability of carrying out both traditional and improved 2D GA analysis, whereas, MDX software can carry out only traditional 2D grid analysis. Figure C.6 compares the vertical deflections obtained from different methods of analysis using different analysis software. The comparison indicates that almost same CDL deflection is obtained from different methods of analysis using different software.



**Figure C.6: Comparison of concrete dead load vertical deflection of Girder 5 of Bridge B obtained from different methods of analysis**

In summary, MDX results are in good match with traditional 2D grid analysis results using FIU software for both Bridge A and Bridge B. This implies that MDX software does not model torsional stiffness of the girders correctly. The warping term is not included in torsional constant used by MDX.

## Appendix D: Design Example



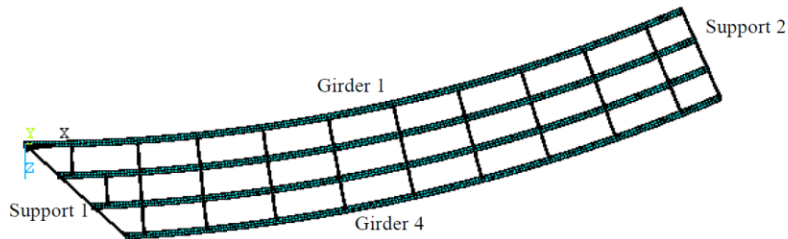
**Table D.1: Girder radius and length**

	<b>Girder 1</b>	<b>Girder 2</b>	<b>Girder 3</b>	<b>Girder 4</b>
Radius of curvature (ft.)	490.25	499.75	509.25	518.75
Arc Length (ft.)	200	203.87557	207.75115	211.62672

**Table D.2: Location of intermediate cross frames**

<b>Cross Frame No</b>	<b>Bay 1</b>	<b>Bay 2</b>	<b>Bay 3</b>
1	1.604282	2.750197	3.896113
2	3.896113	3.896113	5.958761
3	5.958761	5.958761	8.250592
4	8.250592	8.250592	10.54242
5	10.54242	10.54242	12.83425
6	12.83425	12.83425	15.12609
7	15.12609	15.12609	17.41792
8	17.41792	17.41792	19.70975
9	19.70975	19.70975	22.00158
10	22.00158	22.00158	

## Bridge D Input Data



### Bridge Geometry Input

Girder Spacing,  $S_G := 9.5\text{ft}$

Radius of Girder 1,  $R_{G1} := 490.25\text{ft}$

Width of Overhang,  $W_{oh} := 3.8\text{ft}$

### Girder Section Properties

$$b_{bf} := 22\text{in} \quad t_{bf} := 1.75\text{in}$$

$$b_{ft} := b_{bf} \quad t_{ft} := t_{bf}$$

$$b_{tf} := 20\text{in} \quad t_{tf} := 1.25\text{in}$$

$$b_{fc} := b_{tf} \quad t_{fc} := t_{tf}$$

$$h_w := 102\text{in} \quad t_w := 0.75\text{in}$$

### Material Properties

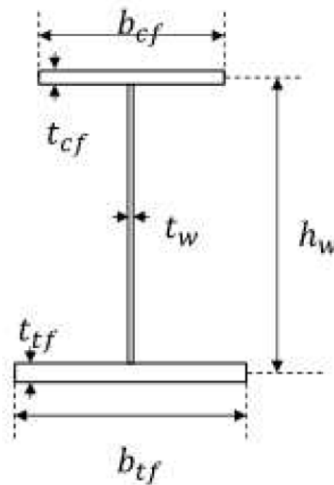
$$E := 29000\text{ksi}$$

$$F_{yf} := 50\text{ksi}$$

$$F_{yw} := 50\text{ksi}$$

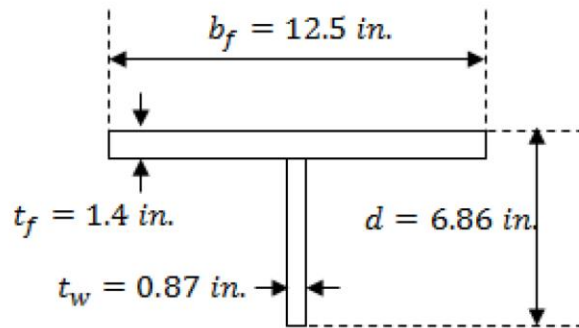
$$F_{yc} := 50\text{ksi}$$

### Cros Frame Bottom Chord (WT 6x76)



Thickness of Bottom Chord  $t_{BC} := 1.4 \text{ in}$

Length of Bottom Chord,  $l_{BC} := S_G$



Radius of gyration of Bottom Chord

$r_{xBC} := 1.61 \text{ in}$

$b_{fBC} := 12.5 \text{ in}$

$r_{yBC} := 3.19 \text{ in}$

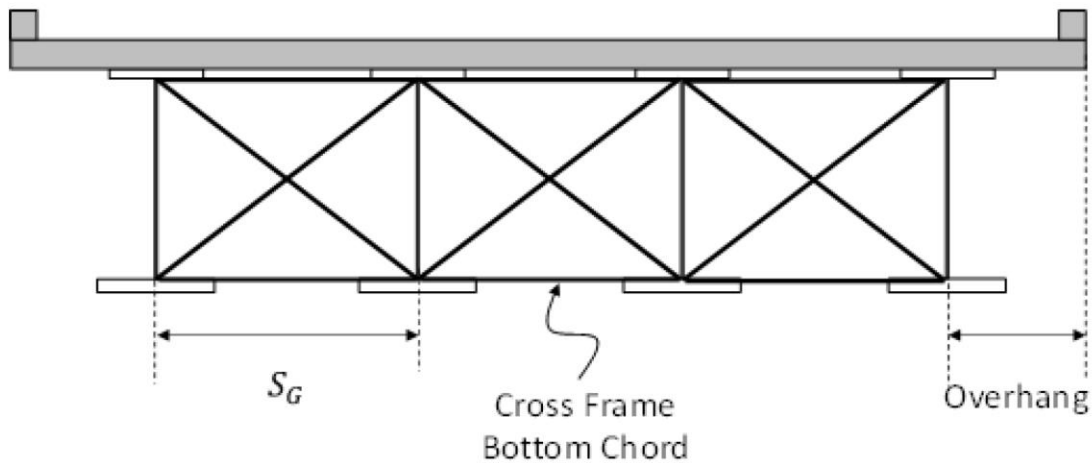
$t_{fBC} := 1.4 \text{ in}$

$r_{BC} := \min(r_{xBC}, r_{yBC})$

Cross section area,  $A_{BC} := 22.4 \text{ in}^2$

$F_{y\text{Brace}} := 50 \text{ ksi}$

$F_{u\text{Brace}} := 65 \text{ ksi}$



## Girder Section Properties Calculations



## Brace Design



## Thickness, Slenderness and brace spacing



### **Minimum thickness of steel (6.7.3)**

$$\text{ThicknessCheck} := t_{BC} \geq 0.3125\text{in} \rightarrow 1.4\text{in} \geq 0.3125\text{in}$$

$$\text{ThicknessCheck} = 1$$

### **Limiting Slenderness Ratio (6.8.4)**

Tension Members

For primary members subject to stress reversals,  $l/r < 140$

For primary members not subject to stress reversals,  $l/r < 200$

For primary members not subject to stress reversals,  $l/r < 240$

Cross frames are considered as primary members in curved bridges (6.7.4.1)

Assuming the cross frame members are not subjected to stress reversals

$$l_{BC} = 114\text{in}$$

$$r_{BC} = 1.61\text{in}$$

$$\text{SlendernessRatio} := \frac{l_{BC}}{r_{BC}} = 70.807$$

$$\text{SlendernessCheckT} := \frac{l_{BC}}{r_{BC}} \leq 200$$

$$\text{SlendernessCheckT} = 1$$

### **Limiting Slenderness Ratio (6.9.3)**

Compression members

For primary members..... $kl/r < 120$

For secondary members..... $kl/r < 140$

$$r_{BC} = 1.61\text{in}$$

$$K_{BC} := .75 \quad (4.6.2.5)$$

$$\frac{K_{BC} \cdot l_{BC}}{r_{BC}} = 53.106$$

$$\text{SlendernessCheckC} := \frac{K_{BC} \cdot l_{BC}}{r_{BC}} \leq 120$$

$$\text{SlendernessCheckC} = 1$$

### Cross frame spacing, Lb (6.7.4.2)

$$F_{yT} := 0.7 \cdot F_{yc} = 35 \cdot \text{ksi}$$

$$r_t = 0.385 \cdot \text{ft}$$

$$L_T := \pi \cdot r_t \cdot \sqrt{\frac{E}{F_{yT}}}$$

$$L_T = 34.844 \cdot \text{ft}$$

Desired bending stress ratio =  $r_{\sigma} = f/f_{bu}$  (maximum value = 0.3)

$$r_{\sigma} := 0.3$$

$$L_b := \sqrt{\frac{5}{3} \cdot r_{\sigma} \cdot R_{G1} \cdot b_{bf}} \quad (\text{C6.7.4.2-1}) \text{ for horizontally curved I-girder bridges}$$

$$L_b = 21.199 \cdot \text{ft}$$

**Selecting  $L_b = 20 \text{ ft}$**

$$L_b := 20 \text{ ft}$$

$$\text{LbCheck1} := L_b \leq L_T = 1 \quad (6.7.4.2-1)$$

$$\text{LbCheck2} := L_b \leq \frac{R_{G1}}{10} = 1 \quad (6.7.4.2-1)$$



---

### **Estimation of Brace Load by refined analysis**



#### Design for constructability

A 2D Grid or 3D FEM analysis can be conducted to calculate the forces

The Finite element model applied with above forces with following combination to get maximum force in the cross frames

Strength I

$$1.25 \cdot (DC + DW) + 1.5 \cdot (CEL + CLL)$$

Strength III

$$1.25 \cdot (DC + DW) + 1.5 \cdot (CEL) + 1.25(WS)$$

Assuming 2 inch wearing surface

### **Lateral Wind Load (4.6.2.7)**

Assuming a typical bridges with conventional levels of redundancy, design and details

$$\eta_i := 1$$

Assuming the bridge to be with in 30ft. above low ground or above design water level  
(3.8.1)

$$P_D := 0.05 \frac{\text{kip}}{\text{ft}^2} \quad (\text{Table 3.8.1.2.2 - 1})$$

$$W_{\text{wind}} := \frac{\eta_i \cdot P_D \cdot h_w}{2}$$

$$W_{\text{wind}} = 0.213 \cdot \frac{\text{kip}}{\text{ft}}$$

Horizontal wind force applied to each brace point,  $P_w$

$$P_{\text{wind}} := W_{\text{wind}} \cdot L_b$$

$$P_{\text{wind}} = 4.25 \cdot \text{kip}$$

This load is applied to exterior girders only as a point load on the brace points in lateral direction

### **Lateral load from Overhang Bracket (6.10.3.4)**

Width of overhang,  $W_{oh} = 3.8 \text{ ft}$       Density of Concrete,  $\gamma_{conc} := 150 \frac{\text{lb}}{\text{ft}^3}$

Deck thickness,  $h_{deck} := 8 \text{ in} = 0.667 \text{ ft}$

Overhang Concrete Load,  $w_1 := h_{deck} \cdot W_{oh} \cdot \gamma_{conc} = 380 \cdot \frac{\text{lb}}{\text{ft}}$

Overhang Deck Form,  $w_2 := 40 \frac{\text{lb}}{\text{ft}}$

Screed rail Load  $w_3 := 85 \frac{\text{lb}}{\text{ft}}$

Railing Load,  $w_4 := 25 \frac{\text{lb}}{\text{ft}}$

Walkway Load,  $w_5 := 125 \frac{\text{lb}}{\text{ft}}$

Finishing Machine,  $P_1 := 3000 \text{ lbf}$

Load combination

$DC1_{oh} := w_1 = 0.38 \frac{\text{kip}}{\text{ft}}$

$CEL_{oh} := w_2 + w_3 + w_3 + w_4 + w_5 = 360 \cdot \frac{\text{lb}}{\text{ft}}$

$CLL_{oh} := P_1$

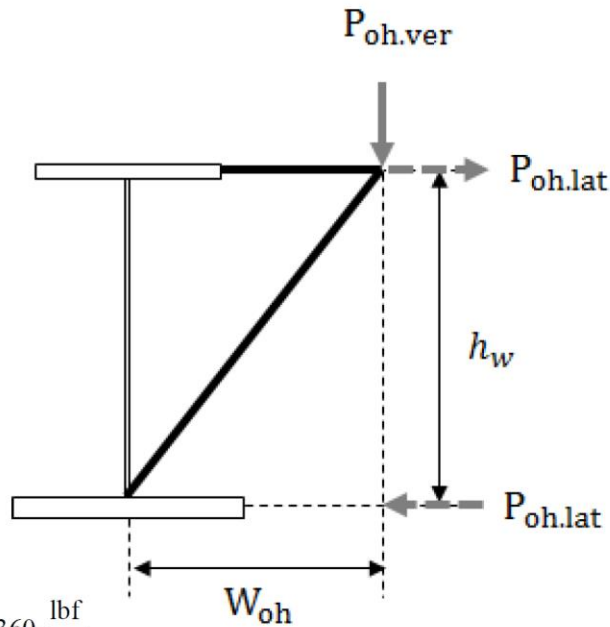
$P_{oh.ver1} := (1.25 \cdot DC1_{oh} + 1.5 \cdot CEL_{oh}) \cdot L_b + 1.5 \cdot CLL_{oh} = 24.8 \cdot \text{kip}$

$P_{oh.lat1} := P_{oh.ver1} \cdot \frac{W_{oh}}{h_w} = 11.087 \cdot \text{kip}$

$P_{oh.lat1}$  is applied at each brace point on exterior girders at top flange and bottom flange for strength limit state I

$P_{oh.ver3} := (1.25 \cdot DC1_{oh} + 1.5 \cdot CEL_{oh}) \cdot L_b = 20.3 \cdot \text{kip}$

$P_{oh.lat3} := P_{oh.ver3} \cdot \frac{W_{oh}}{h_w} + 1.25 \cdot P_{wind} = 14.388 \cdot \text{kip}$



A 2D Grid or 3D FEM analysis can be conducted to calculate the forces

The Finite element model applied with above forces with following combination to get maximum

force in the cross frames

Strength I

$$1.25 \cdot (DC + DW) + 1.5 \cdot (CEL + CLL)$$

Strength III

$$1.25 \cdot (DC + DW) + 1.5 \cdot (CEL) + 1.25(WS)$$

After conducting the analysis maximum tension and compression in

$$P_{uT} := 201 \text{kip}$$

$$P_{uC} := 89 \text{kip}$$



---

### Checking for maximum tension



#### Tensile Resistance (6.8.2)

Tension Capacity is minimum of  $P_{r1}$  and  $P_{r2}$

$$\phi_y := 0.95 \quad (6.5.4.2)$$

$$F_y := F_{y\text{Brace}} = 50 \cdot \text{ksi}$$

$$A_g := A_{BC} = 22.4 \cdot \text{in}^2$$

$$P_{r1} := \phi_y \cdot F_y \cdot A_g = 1.064 \times 10^3 \cdot \text{kip}$$

$$\phi_u := 0.80 \quad (6.5.4.2)$$

$$F_u := F_{u\text{Brace}} = 65 \cdot \text{ksi}$$

welded to the connection plate to net area is same as gross area

$$A_n := A_g$$

$$\text{Reduction Factor for holes, } R_p := 1$$

$$\text{Shear Lag Reduction Factor, } U := 0.85$$

$$P_{r2} := \phi_u \cdot F_u \cdot A_n \cdot R_p \cdot U = 990.08 \cdot \text{kip}$$

$$P_{rT} := \min(P_{r1}, P_{r2}) = 990.08 \cdot \text{kip}$$

$$P_{uT} = 201 \cdot \text{kip}$$

$$P_{rT} \geq P_{uT} = 1$$



---

### Checking for maximum compression



#### Nominal compressive Resistance (6.9.4.1)

$$K_{BC} = 0.75$$

$$l_{BC} = 9.5 \text{ ft}$$

$$r_{BC} = 1.61 \cdot \text{in}$$

$$l_{\text{eff}} := \frac{K_{BC} \cdot l_{BC}}{r_{BC}} = 53.106$$

$$E = 2.9 \times 10^4 \cdot \text{ksi}$$

$$A_g = 22.4 \cdot \text{in}^2$$

$$P_e := \frac{\pi^2 \cdot E}{(l_{\text{eff}})^2} \cdot A_g = 2.273 \times 10^3 \cdot \text{kip}$$

### **Nonslender Member Element (6.9.4.2.1)**

$$\text{Effective width } b_{BC} := \frac{b_{fBC}}{2} = 6.25 \cdot \text{in} \quad (6.9.4.2.1 - 1)$$

$$\text{Plate buckling coefficient, } k_{1BC} := 0.56$$

$$\frac{b_{BC}}{t_{fBC}} = 4.464$$

$$k_{1BC} \cdot \sqrt{\frac{E}{F_y}} = 13.487$$

$$\text{Nonslender} := \frac{b_{BC}}{t_{fBC}} \leq k_{1BC} \cdot \sqrt{\frac{E}{F_y}}$$

$$\text{Nonslender} = 1$$

$$Q := 1$$

$$P_o := Q \cdot F_y \cdot A_g = 1.12 \times 10^3 \cdot \text{kip}$$

$$\frac{P_e}{P_o} = 2.03$$

$$P_{n1} := \left[ 0.658 \left( \frac{P_o}{P_e} \right) \right] \cdot P_o = 911.306 \cdot \text{kip} \quad (6.9.4.4.4 - 1)$$

$$P_{n2} := 0.877 \cdot P_e = 1.994 \times 10^3 \cdot \text{kip}$$

$$P_n := \begin{cases} P_{n1} & \text{if } \frac{P_e}{P_o} \geq 0.44 \\ P_{n2} & \text{otherwise} \end{cases}$$

$$P_n = 911.306 \cdot \text{kip}$$

$$\phi_c := 0.9 \quad (6.5.4.2)$$

$$P_{rC} := \phi_c \cdot P_n = 820.175 \cdot \text{kip}$$





# Appendix E: Girder and cross frame stiffness matrix

## E.1 Girder Stiffness Matrix

### E.1.1 Traditional

```
aa=A*E/Le;  
gg=G*J/Le; %For using simple J  
  
az=12*E*Iz/Le^3;  
cz=6*E*Iz/Le^2;  
ez=4*E*Iz/Le;  
fz=2*E*Iz/Le;  
  
ay=12*E*Iy/Le^3;  
cy=6*E*Iy/Le^2;  
ey=4*E*Iy/Le;  
fy=2*E*Iy/Le;  
  
Ke=[aa 0 0 0 0 0 -aa 0 0 0 0 0  
0 az 0 0 0 cz 0 -az 0 0 0 cz  
0 0 ay 0 -cy 0 0 0 -ay 0 -cy 0  
0 0 0 gg 0 0 0 0 0 -gg 0 0  
0 0 -cy 0 ey 0 0 0 cy 0 fy 0  
0 cz 0 0 0 ez 0 -cz 0 0 0 fz  
-aa 0 0 0 0 0 aa 0 0 0 0 0  
0 -az 0 0 0 -cz 0 az 0 0 0 -cz  
0 0 -ay 0 cy 0 0 0 ay 0 cy 0  
0 0 0 -gg 0 0 0 0 0 gg 0 0  
0 0 -cy 0 fy 0 0 0 cy 0 ey 0  
0 cz 0 0 0 fz 0 -cz 0 0 0 ez  
1];
```

Le is the length of the element, Iy is moment of inertia about minor axis, Iz is moment of inertia about major axis, and E is modulus of elasticity of steel.

```
%section properties  
G=E/(2*(1+nue));  
  
Atf=btf*ttf;  
Aw=hw*tw;  
Abf=bbf*tbf;  
  
Area=Atf+Aw+Abf;  
  
MArea=Atf*hw+Aw*hw/2;  
NA=MArea/Area;  
  
Itfz=btf*ttf^3/12+Atf*(hw-NA)^2;  
Iwz=tw*hw^3/12+Aw*(hw/2-NA)^2;  
Ibfz=bbf*tbf^3/12+Abf*(NA)^2;  
  
Iz=Itfz+Iwz+Ibfz;  
  
Itfy=ttf*btf^3/12;  
Iwy=hw*tw^3/12;  
Ibfy=tbf*bbf^3/12;  
  
Iy=Itfy+Iwy+Ibfy;  
  
J=1/3*(btf*ttf^3+hw*tw^3+bbf*tbf^3);
```

nue is poissons ration taken equal to 0.3, btf is width of top flange, ttf is thickness of top flange, bbf is width of bottom flange, tbf is thickness of bottom flange, hw is height of web.

### E.1.2 Improved

```

aa=A*E/Le;
gg=G*Jeq/Le; %For using Jeq

az=12*E*Iz/Le^3;
cz=6*E*Iz/Le^2;
ez=4*E*Iz/Le;
fz=2*E*Iz/Le;

ay=12*E*Iy/Le^3;
cy=6*E*Iy/Le^2;
ey=4*E*Iy/Le;
fy=2*E*Iy/Le;

Ke=[aa 0 0 0 0 0 -aa 0 0 0 0 0
    0 az 0 0 0 cz 0 -az 0 0 0 cz
    0 0 ay 0 -cy 0 0 0 -ay 0 -cy 0
    0 0 0 gg 0 0 0 0 0 -gg 0 0
    0 0 -cy 0 ey 0 0 0 cy 0 fy 0
    0 cz 0 0 0 ez 0 -cz 0 0 0 fz
    -aa 0 0 0 0 0 aa 0 0 0 0 0
    0 -az 0 0 0 -cz 0 az 0 0 0 -cz
    0 0 -ay 0 cy 0 0 0 ay 0 cy 0
    0 0 0 -gg 0 0 0 0 0 gg 0 0
    0 0 -cy 0 fy 0 0 0 cy 0 ey 0
    0 cz 0 0 0 fz 0 -cz 0 0 0 ez
    ];

```

This matrix uses Jeq calculated as follows:

```

J=1/3*(btf*ttf^3+hw*tw^3+bbf*tbf^3);
Cw=hw^2*bbf^3*tbf*1/(12*(1+(bbf/btf)^3*(tbf/ttf)));

p=sqrt(G*J/(E*Cw));
q=p*Lbi;

if Bci==0
    Jeq=J/(1-sinh(q)/q+(cosh(q)-1)^2/(q*sinh(q))); %Jeq for Fix-Fix condition
elseif Bci==1
    Jeq=J/(1-sinh(q)/(q*cosh(q))); %Jeq for Free-Fix condition
end

```

Lbi is the unbrace length of the particular element. All the elements between two consecutive cross have same un-braced length equal to distance between the two consecutive cross frames. Rest of the calculations is same as in traditional matrix for girders.

## E.2 Cross-frame Stiffness Matrix

### E.2.1 Traditional

The following matrix is for X-type cross-frame.

```
Le = sqrt((Xj - Xi) ^ 2 + (Yj - Yi) ^ 2 + (Zj - Zi) ^ 2); %Length of element
Ld = sqrt(Le^2+hb^2);

% _____ Traditional Cross Frame Matrix _____

Ke(1,1)=E/Le*(Ab+At)+E*Le^2/Ld^3*(Ad1+Ad2);

Ke(2,1)=0; % Ke(2,1)=Ke(1,2);
Ke(2,2)=E*hb^2/Ld^3*(Ad1+Ad2);

Ke(3,3)=12*E/Le^3*(Ib+It);

Ke(4,3)=6*E*hb/Le^3*(Ib-It); % Ke(3,4)=Ke(4,3);
Ke(4,4)=3*E*hb^2/Le^3*(It+Ib);

Ke(5,3)=-6*E*hb/Le^2*(It+Ib); % Ke(3,5)=Ke(5,3);
Ke(5,4)=3*E*hb/Le^2*(Ib-It); % Ke(4,5)=Ke(5,4);
Ke(5,5)=4*E/Le*(Ib+It);

Ke(6,1)=0; % Ke(1,6)=Ke(6,1);
Ke(6,2)=E*hb^2*Le/(2*Ld^3)*(Ad1+Ad2); % Ke(2,6)=Ke(6,2);
Ke(6,6)=E*hb^2/(4*Le)*(Ab+At)+E*hb^2*Le^2/(4*Ld^3)*(Ad1+Ad2);

Ke(7,1)=-E/Le*(Ab+At)-E*Le^2/Ld^3*(Ad1+Ad2); % Ke(1,7)=Ke(7,1);
Ke(7,2)=0; % Ke(2,7)=Ke(7,2);
Ke(7,6)=0; % Ke(6,7)=Ke(7,6);
Ke(7,7)=E/Le*(Ab+At)+E*Le^2/Ld^3*(Ad1+Ad2);

Ke(8,1)=0; % Ke(1,8)=Ke(8,1);
Ke(8,2)=-E*hb^2/Ld^3*(Ad1+Ad2); % Ke(2,8)=Ke(8,2);
Ke(8,6)=-E*hb^2*Le/(2*Ld^3)*(Ad1+Ad2); % Ke(6,8)=Ke(8,6);
Ke(8,7)=0; % Ke(7,8)=Ke(8,7);
Ke(8,8)=E*hb^2/Ld^3*(Ad1+Ad2);

Ke(9,3)=-12*E/Le^3*(Ib+It); % Ke(3,9) = Ke(9,3);
Ke(9,4)=6*E*hb/Le^3*(Ib-It); % Ke(4,9) = Ke(9,4);
Ke(9,5)=6*E/Le^2*(Ib+It); % Ke(5,9) = Ke(9,5);
Ke(9,9)=12*E/Le^3*(It+Ib);
```

```

Ke(10,3)=6*E*hb/Le^3*(Ib-It);
Ke(10,4)=-3*E*hb^2/Le^3*(It+Ib);
Ke(10,5)=3*E*hb/Le^2*(It-Ib);
Ke(10,9)=6*E*hb/Le^3*(It-Ib);
Ke(10,10)=3*E*hb^2/Le^3*(Ib+It);

Ke(11,3)=-6*E/Le^2*(It+Ib);
Ke(11,4)=3*E*hb/Le^2*(Ib-It);
Ke(11,5)=2*E/Le*(Ib+It);
Ke(11,9)=6*E/Le^2*(It+Ib);
Ke(11,10)=3*E*hb/Le^2*(It-Ib);
Ke(11,11)=2*E/Le*(It+Ib);

Ke(12,1)=0;
Ke(12,2)=E*hb^2*Le/(2*Ld^3)*(Ad1+Ad2);
Ke(12,6)=-E*hb^2/(4*Le)*(Ab+At)+E*hb^2*Le^2/(4*Ld^3)*(Ad1+Ad2);
Ke(12,7)=0;
Ke(12,8)=-E*hb^2*Le/(2*Ld^3)*(Ad1+Ad2);
Ke(12,12)=E*hb^2/(4*Le)*(Ab+At)+E*hb^2*Le^2/(4*Ld^3)*(Ad1+Ad2);

Ke(3,10) = Ke(10,3);
Ke(4,10) = Ke(10,4);
Ke(5,10) = Ke(10,5);
Ke(9,10) = Ke(10,9);

Ke(3,11) = Ke(11,3);
Ke(4,11) = Ke(11,4);
Ke(5,11) = Ke(11,5);
Ke(9,11) = Ke(11,9);
Ke(10,11) = Ke(11,10);

Ke(1,12) = Ke(12,1);
Ke(2,12) = Ke(12,2);
Ke(6,12) = Ke(12,6);
Ke(7,12) = Ke(12,7);
Ke(8,12) = Ke(12,8);

```

Le is length of cross frame element equal to spacing between the girders, Ld is length of diagonal members in X-type cross frame, Ab is cross section area of bottom chord, At is cross section area of top chord, Ad1 is cross section area of diagonal 1 and Ad2 is cross section area of diagonal 2, hb is height of bracing or cross frame, Ib is moment of inertia of bottom chord about an axis parallel to height of cross-frame, It is moment of inertia of top chord about an axis parallel to height of cross-frame.

## E.2.2 Improved

Add following to the traditional matrix

```

% Improved Cross Frame Matrix
Ke(2,1)=E*Le*hb/Ld^3*(Ad2-Ad1);
Ke(6,1)=E*hb/(2*Le)*(Ab-At)+E*hb*Le^2/(2*Ld^3)*(Ad2-Ad1);
Ke(7,2)=E*Le*hb/Ld^3*(Ad1-Ad2);
Ke(7,6)=E*hb/(2*Le)*(Ab-At)+E*hb*Le^2/(2*Ld^3)*(Ad2-Ad1);
Ke(8,1)=E*Le*hb/Ld^3*(Ad1-Ad2);
Ke(8,7)=E*hb*Le/Ld^3*(Ad2-Ad1);
Ke(12,1)=E*hb/(2*Le)*(At-Ab)+E*hb*Le^2/(2*Ld^3)*(Ad2-Ad1);
Ke(12,7)=E*hb/(2*Le)*(Ab-At)+E*hb*Le^2/(2*Ld^3)*(Ad2-Ad1);

Ke(2,1)=Ke(1,2);
Ke(1,6)=Ke(6,1);
Ke(2,7)=Ke(7,2);
Ke(6,7)=Ke(7,6);
Ke(1,8)=Ke(8,1);
Ke(7,8)=Ke(8,7);
Ke(1,12)=Ke(12,1);
Ke(7,12)=Ke(12,7);

```

### E.3 Comparison of results using improved and traditional cross frame matrix

In order to evaluate improvement made by improved cross frame matrix, flange lateral bending stress and cross frames forces are compared. It has been found that both responses have almost the same value for both improved and traditional cross frame matrix. The improved cross frame matrix does not significantly improve the result.

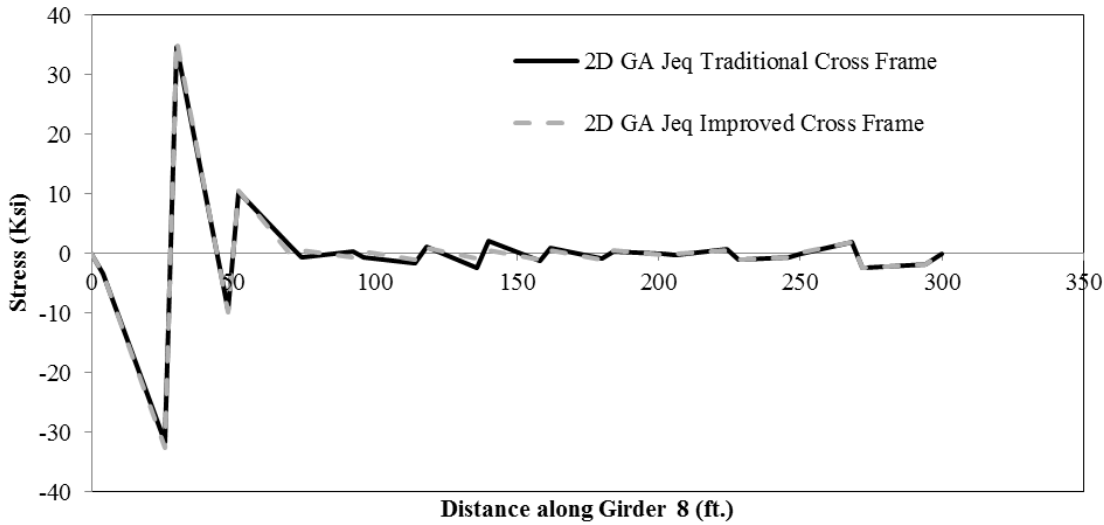


Figure E.1: Flange lateral bending stress along length of girder 8 of Bridge A

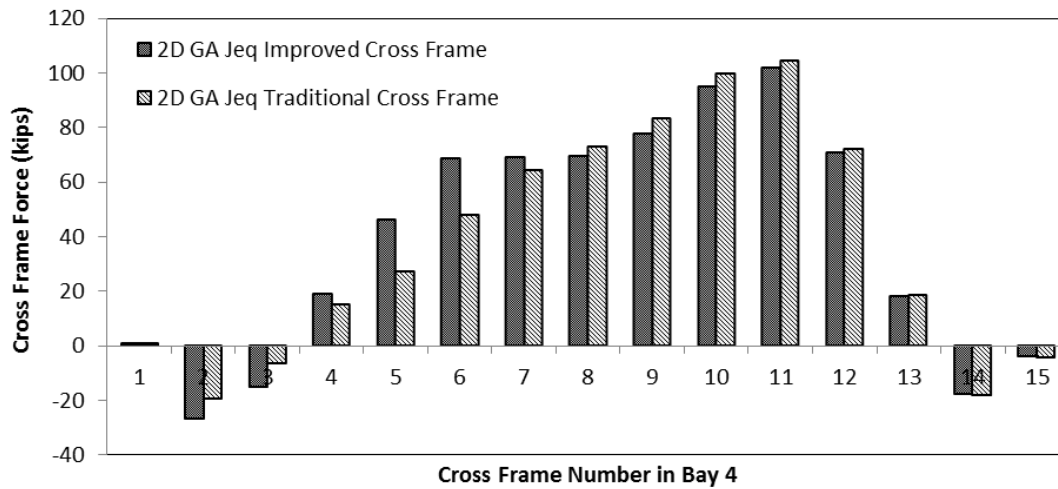


Figure E.2: Cross frames forces in bottom chord of cross frames in bay 4 of Bridge A