



Florida Department of Transportation

RICK SCOTT
GOVERNOR

605 Suwannee Street
Tallahassee, FL 32399-0450

JIM BOXOLD
SECRETARY

STRUCTURES DESIGN BULLETIN 16-07

(FHWA Approved: July 20, 2016)

DATE: July 22, 2016

TO: District Directors of Transportation Operations, District Directors of Transportation Development, District Design Engineers, District Construction Engineers, District Structures Design Engineers, District Structures Maintenance Engineers, Structures Manual Holders

FROM: Robert V. Robertson, P. E., State Structures Design Engineer

COPIES: Brian Blanchard, Phillip Gainer, Tim Lattner, David Sadler, Rudy Powell, Amy Tootle, Daniel Scheer, Bruce Dana, Gregory Schiess, Trey Tillander, SDO Staff, Jeffrey Ger (FHWA)

SUBJECT: Design and Detailing Requirements for Post-Tensioning Tendons

This bulletin updates existing policy in the *Structures Manual* for post-tensioning tendons. This bulletin also announces *Design Standards Revisions* in the *FY 2016-2017 Design Standards eBook* and associated *Instructions for Design Standards* for Indexes 21801, 21802 and 21803.

REQUIREMENTS

1. Replace *Structures Design Guidelines* Section 1.11.1.B with the following:

B. Design and detail all tendons that utilize flexible filler to be unbonded, fully replaceable, meet anchorage clearance requirements of *SDG* Table 1.11.1-1, and have clearance at the anchorages for jacking and future tendon replacement operations. Prior approval from the SDO is required for the following cases:

1. Design for replaceable tendons that requires complete or partial removal of deck or diaphragm concrete.
2. Stressing end anchorages located in locations that require demolition to replace tendons.
3. Anchorage blisters on the exterior face of a fascia I-beam or girder other than as shown in *SDM* Figures 23.7-1 and 23.7-2, on the exterior of a U-beam or girder, or on the exterior of a box girder.

Table 1.11.1-1 Minimum Clearance Requirements at Anchorages for Replaceable Strand and Wire Tendons

Anchorage Type and Location	Minimum Clearance Requirement	Example Detail
Stressing End Anchorage Near Deviator	Stressing Jack Envelope + 3'-0" (min.)	<i>SDM</i> Figure 20.8-1
Stressing End Anchorage at Intermediate Diaphragm Near Minor Obstruction ¹	Stressing Jack Envelope + 1'-0" (min.)	<i>SDM</i> Figure 20.8-2
Non-Stressing End Anchorage Near Abutment	$2'-6" + \Delta_T$ $\Delta_T = \text{Maximum Design Thermal Expansion}$	<i>SDM</i> Figure 20.8-3 <i>SDM</i> Figure 23.7-3
Non-Stressing End Near Other Structure	$2'-6" + \sum \Delta_T$ $\sum \Delta_T = \text{Summation of Maximum Design Thermal Expansion of both adjacent structures}$	<i>SDM</i> Figure 20.8-4 <i>SDM</i> Figure 23.7-4
Stressing End Anchorage at Other Locations	Jacking Envelope with fully extended piston, including Maximum Design Thermal Expansion (if applicable) and sufficient clearance for pulling existing tendon and installation of new tendon (Prior SDO approval is required to use this approach at locations other than webs of I-girders as shown in <i>SDM</i> Figures 23.7-1 and 23.7-2)	<i>SDM</i> Figures 23.7-1 and 23.7-2
Non-Stressing End Anchorage at Other Locations	2'-6" plus Maximum Design Thermal Expansion (if applicable)	-

¹ A minor obstruction is a bridge component or projection that does not impede future tendon replacement operations.

*Commentary: In general, permanent strand tail extensions will not be required for replaceable tendons. The use of non-stressing ends of tendons located at bridge end diaphragms is desirable due to reduced clearance requirements at the anchorages. Visible anchorage blisters, such as web blisters, are generally not desirable for aesthetic reasons. Anchorages embedded within a thickened web section that are not visibly distinct are preferred (See *SDM* Figures 23.7-1 and 23.7-2).*

2. Replace *Structures Design Guidelines* Section 1.11.4 with the following:

1.11.4 Ducts

- A. Design and detail using smooth wall polyethylene (PE) duct and/or steel pipe and associated couplers that meet the requirements of *Specifications* Section 960 for all external tendons, and for internal tendons with flexible filler. Specify the use of steel pipe where PE duct cannot be used due to minimum bending radius limitations.
- B. Design and detail using corrugated polypropylene (PP) duct and/or steel pipe and associated couplers that meet the requirements of *Specifications* Section 960 for grouted internal tendons. Specify the use of steel pipe where PP duct cannot be used due to minimum bending radius limitations.
- C. Design and detail using the maximum duct external dimensions shown in Table 1.11.4-1 for laying out tendon geometries and checking for clearances and required concrete cover in post-tensioned members.

Modification for Non-Conventional Projects:

Delete *SDG* 1.11.4.C and insert the following:

- C. Design and detail using project specific maximum duct external dimensions for laying out tendon geometries and checking for clearances and required concrete cover in post-tensioned members.

Table 1.11.4-1 Maximum Duct External Dimensions for Detailing

Tendon Size and Type	Corrugated Duct Outside Diameter		Smooth Wall Duct Outside Diameter	
	For use with Strand and Wire Tendons, and Bar Tendons without Couplers	For use with Bar Tendons with Couplers ¹	For use with Strand and Wire Tendons, and Bar Tendons without Couplers	For use with Bar Tendons with Couplers ¹
4 - 0.6 strands	1.54" x 3.55" (Flat duct)	N/A	3.50"	N/A
7 - 0.6 strands	2.87"	N/A	3.50"	N/A
12 - 0.6 strands	3.63"	N/A	3.50"	N/A
15 - 0.6 strands	3.95"	N/A	4.50"	N/A
19 - 0.6 strands	4.57"	N/A	4.50"	N/A
27 - 0.6 strands	5.30"	N/A	5.563"	N/A
31 - 0.6 strands	5.95"	N/A	5.563"	N/A
1" diameter bar	2.87"	4.09"	3.50"	3.50"
1 1/4" diameter bar	2.87"	4.09"	3.50"	3.50"
1 3/8" diameter bar	2.87"	4.09"	3.50"	3.50"
1 3/4" diameter bar	3.63"	4.57"	3.50"	4.50"
2 1/2" diameter bar	3.95"	5.95"	4.50"	5.563"
3" diameter bar	4.57"	7.00"	4.50"	6.625"

¹ Use duct dimensions as shown for bar tendons with couplers:

- a. For the full length of the bar tendon if its length exceeds 45 feet (including the length of bar needed for stressing and anchoring) and coupler locations are not known, or cannot be designed for and specified in the Plans.
- b. For a minimum distance of 3 times the coupler length at specified coupler locations, e.g. for bar tendons used in precast segmental piers and vertical bar tendons in C-piers that extend from the footings, through the columns and into the caps.

Modification for Non-Conventional Projects:

Delete *SDG* Table 1.11.4.-1 and use the appropriate maximum duct external dimensions from the selected post-tensioning system. Accommodate the use of bar tendon couplers as required.

D. Specify duct geometry in the plans measured to the centerline of the duct. Design ducts to meet or exceed the minimum duct radii and tangent lengths shown in Table 1.11.4-2. For ducts that follow circular curvature or combinations of tangent and circular curvature, show radii and dimensions to points of curvature and tangency (PC and PT points). For ducts that follow parabolic curvature or combinations of tangent and parabolic curvature, show offset dimensions from fixed surfaces, e.g. the bottom of the beam, or clearly defined reference lines at intervals not exceeding 3 feet. For ducts that deviate in both the vertical and horizontal planes, show the required dimensions in elevation and plan views, respectively.

Table 1.11.4-2 Minimum Duct Radius and Tangent Length

Tendon Size	Minimum Duct Radius Between Two Tangents (ft)	Minimum Duct Radius and Tangent Length Adjacent to Anchorages (See Figure 1.11.4-1)	
		Minimum Radius R (ft)	Minimum Tangent Length L (ft)
4- 0.6" diameter strands	6	9	3
7- 0.6" diameter strands	6	9	3
12- 0.6" diameter strands	8	11	3
15- 0.6" diameter strands	9	12	3
19- 0.6" diameter strands	10	13	5
27- 0.6" diameter strands	13	16	5
31- 0.6" diameter strands	13	16	5

Figure 1.11.4-1 Minimum Duct Radius and Tangent Length Adjacent to Anchorages

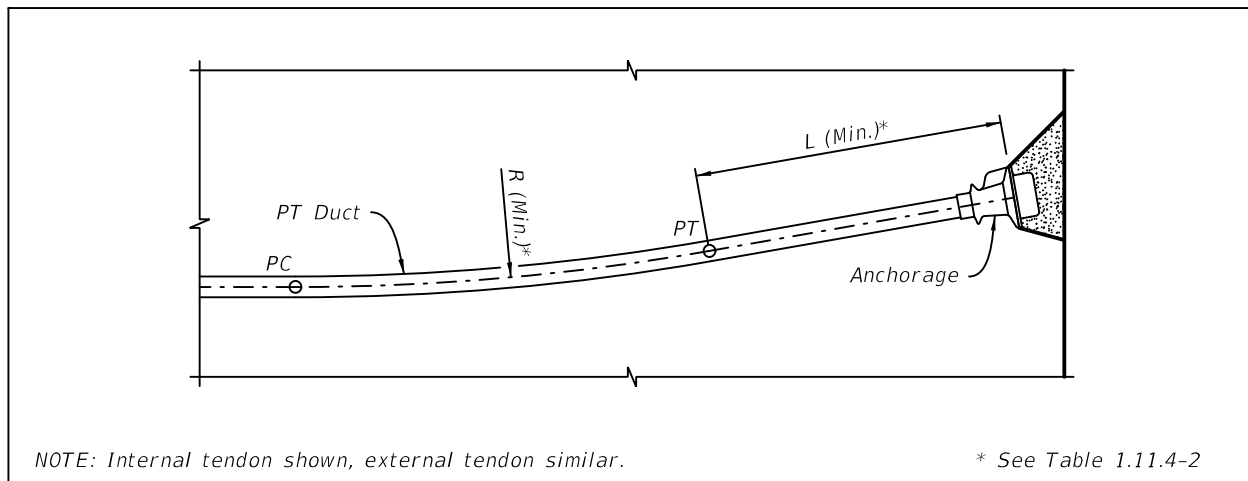

E. Design and detail ducts for external tendons as follows:

1. Design and detail duct geometry using Diabolos at the faces of all pier diaphragms, deviators, and blisters without anchorages. See **SDM** Figure 20.8-10 for Diabolo details.
2. At pier diaphragms with anchorages and at blisters without anchorages, design and detail using ducts that are embedded in the concrete and not removable as shown in **SDM** Figures 20.8-5, 20.8-6 and 20.8-7.

3. At pier diaphragms without anchorages and at deviators, design and detail using smooth formed holes and completely removable ducts that are external to the concrete as shown in *SDM* Figures 20.8-8 and 20.8-9.
 4. To allow room for the installation of duct couplers, design and detail all external tendons to provide a 1½-inch clearance between the outer duct surface and the adjacent face of the concrete as shown in *SDM* Figure 20.8-9.
- F. Design and detail using segmental duct couplers for all internal tendon ducts at all joints between precast elements. Lay out internal tendon ducts with segmental duct couplers as shown in Figure 1.11.4-2.

Figure 1.11.4-2 Layout of Internal Tendons with Segmental Duct Couplers

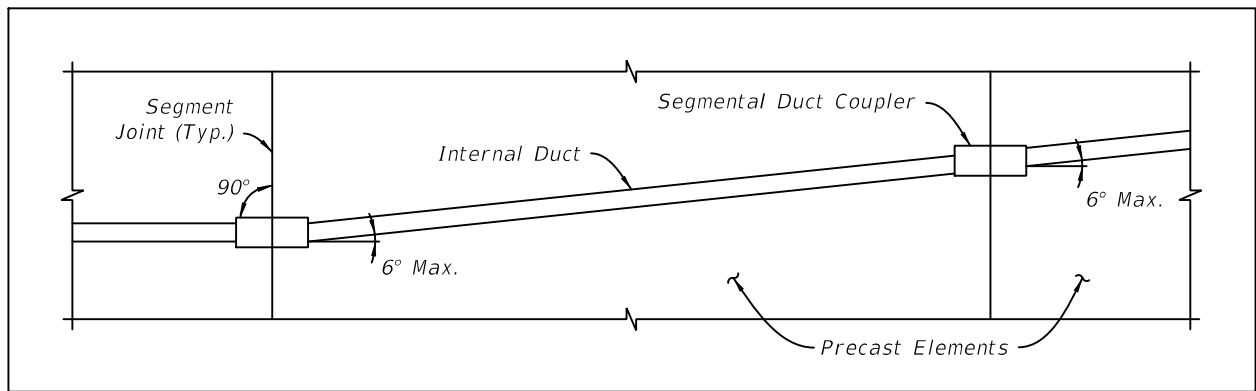

Commentary: Segmental duct couplers shall be made normal to joints to allow stripping of the bulkhead forms. Theoretically, the tendon must pass through the coupler without touching the duct or coupler. Over-sizing couplers allows for standardized bulkheads and avoids the use of curved tendons.

- G. Refer to the list of Approved Post Tensioning Systems for additional details and dimensions of other post-tensioning hardware components.
3. Replace *Structures Design Guidelines* Sections 1.11.5.A, B and C with the following:
- A. Design and detail all tendons to be unbonded except those listed in Paragraphs B and C below. For unbonded tendons, specify the use of flexible filler in the *Design Standards* Index 21800 Series data tables and include the data tables in the Plans.
 - B. Design and detail the following internal strand tendons with predominantly flat geometries to be bonded:
 1. Top slab cantilever longitudinal tendons in segmental box girders
 2. Top slab transverse tendons in segmental box girders
 3. Tendons that are draped 2'-0" or less in post-tensioned slab type superstructuresFor bonded tendons, specify the use of grout in the *Design Standards* Index 21800 Series data tables and include the data tables in the Plans.

C. Design and detail the following tendons to be bonded or unbonded:

1. Straight strand or parallel wire tendons in U-beams and girders
2. Bar tendons (predominately vertical or horizontal)

For these tendons, specify the use of grout for bonded designs or flexible filler for unbonded designs in the *Design Standards* Index 21800 Series data tables and include the data tables in the Plans.

4. Replace *Structures Design Guidelines* Paragraph 3.11.1.H with the following:

H. Design and detail post-tensioned substructure elements to meet or exceed the minimum center-to-center duct spacings in accordance with Table 3.11.1-2 using duct diameters shown in *SDG* Table 1.11.4-1.

5. Replace *Structures Design Guidelines* Table 3.11.1-2 with the following and add Figures 3.11.1-1 and 3.11.1-2:

Table 3.11.1-2 Minimum Center-to-Center Duct Spacing

Post-Tensioned Substructure Element	Minimum Center To Center Vertical Spacing “d” between Ducts	Minimum Center To Center Horizontal Spacing “s” between Ducts¹
C.I.P. Hammerhead, Straddle Beam, Pile/Drilled Shaft or C-Pier Cap (See <i>SDG</i> Figure 3.11.1-1)	Outer duct diameter plus 1.5 times maximum aggregate size, or outer duct diameter plus 2-inches, whichever is greater.	Outer duct diameter plus 3-inches
Precast Segmental Hammerhead, Straddle Beam, Pile/Drilled Shaft or C-Pier Cap (See <i>SDG</i> Figure 3.11.1-1)	2 times outer duct diameter plus 1-inch, or outer segmental coupler diameter plus 2-inches, whichever is greater.	2 times outer duct diameter plus 1-inch, or outer segmental coupler diameter plus 2-inches, whichever is greater.
C.I.P. Solid or Hollow Pier Column (See <i>SDG</i> Figure 3.11.1-2)	N/A	Outer duct diameter plus 3-inches
Precast Segmental Solid or Hollow Pier Column (See <i>SDG</i> Figure 3.11.1-2)	N/A	2 times outer duct diameter plus 1-inch, or outer segmental coupler diameter plus 2-inches, whichever is greater.

1. Usually ducts are placed in-line with PT anchorages. PT anchorage spacing is typically controlled by the size of the spirals and anchorage plates.

Figure 3.11.1-1 Section Through Post-Tensioned Pier/Beam Caps Showing Duct Spacings

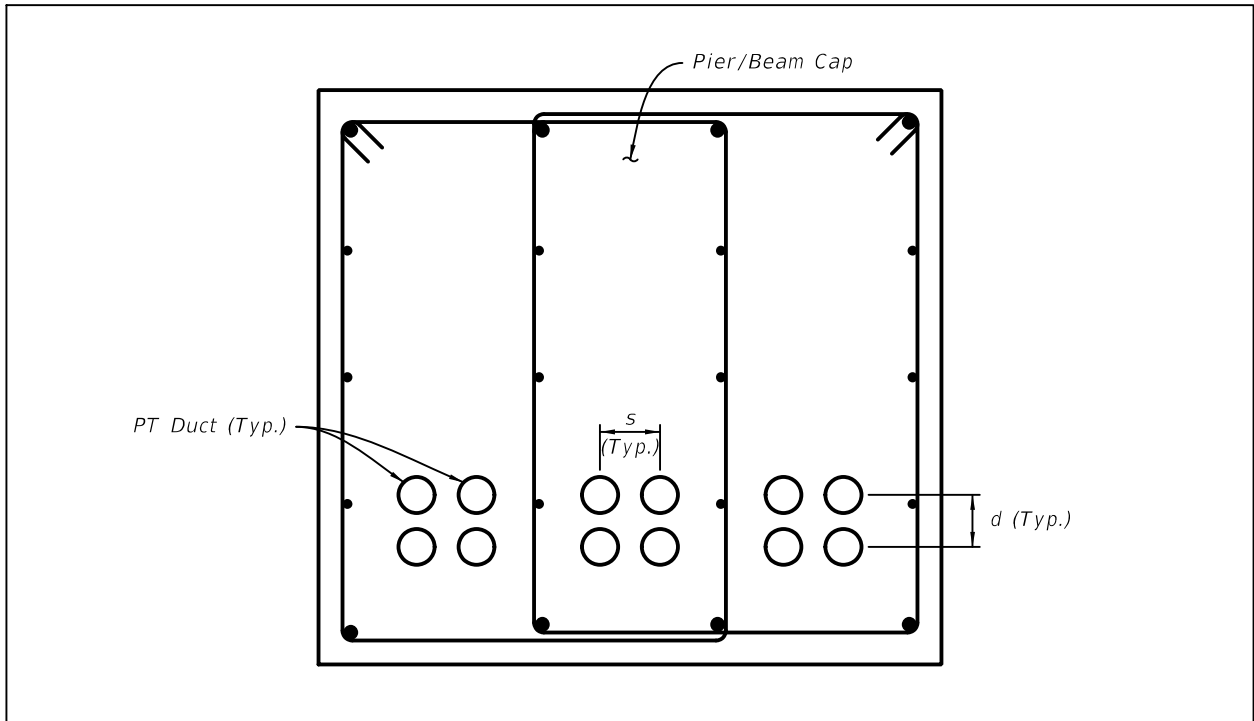
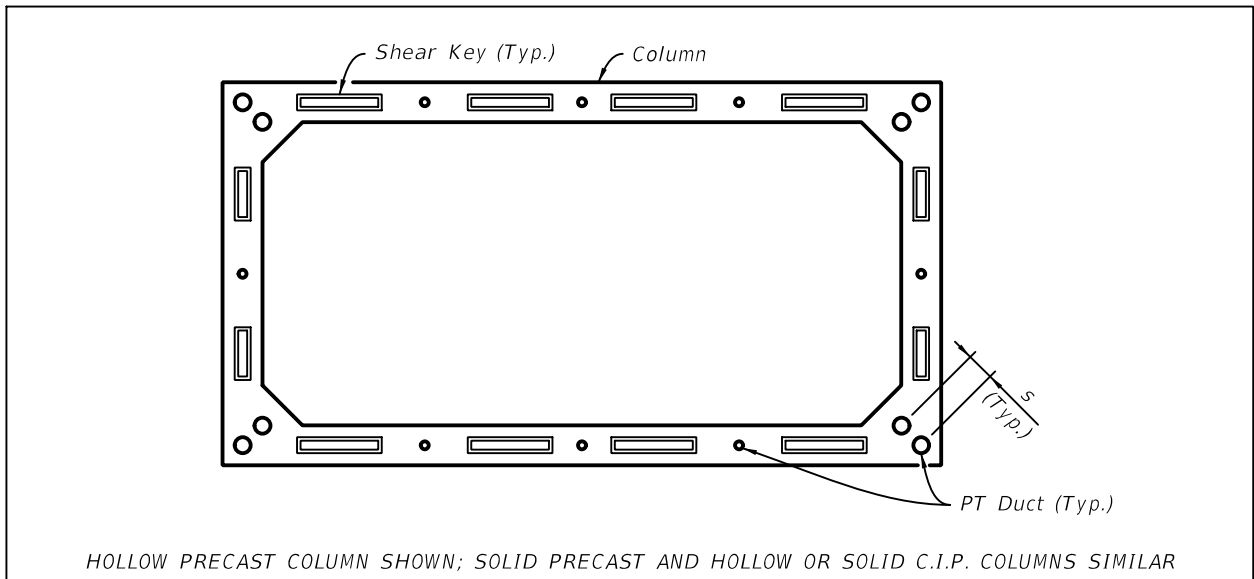

Figure 3.11.1-2 Section Through Post-Tensioned Columns Showing Duct Spacings



6. Add the following to *Structures Design Guidelines* Section 4.4.1:
 - C. Provide a minimum 8" cover from the top of the slab to the top of post tensioning ducts used for unbonded tendons.
 - D. Provide a minimum 8" cover from the top of the slab to the top of voids in a voided slab.

7. Add the following to *Structures Design Guidelines* Table 4.5.2-1:

Post-Tensioned Superstructure Element	Minimum Number of Tendons
Integral Pier Caps (Hammerhead, Straddle, etc.)	See <i>SDG</i> Table 3.11.1-1

8. Replace *Structures Design Guidelines* Section 4.5.3 with the following and add Figures 4.5.3-1 and 4.5.3-2:

4.5.3 Duct Spacing

Design and detail post-tensioned superstructure elements to meet or exceed the minimum center-to-center duct spacings in accordance with Table 4.5.3-1 using duct diameters shown in *SDG* Table 1.11.4-1.

Table 4.5.3-1 Minimum Center-to-Center Duct Spacing

Post-Tensioned Superstructure Type	Minimum Center To Center Vertical Spacing “d” between Longitudinal Ducts ¹	Minimum Center To Center Horizontal Spacing “s” between Longitudinal Ducts ¹
Precast Balanced Cantilever Segmental Bridges (See <i>SDG</i> Figure 4.5.3-1)	2 times outer duct diameter plus 1-inch, or outer segmental coupler diameter plus 2-inches, whichever is greater.	2 times outer duct diameter plus 1-inch, or outer segmental coupler diameter plus 2-inches, whichever is greater.
C.I.P. Balanced Cantilever Segmental Bridges (See <i>SDG</i> Figure 4.5.3-1)	Outer duct diameter plus 1.5 times maximum aggregate size, or outer duct diameter plus 2-inches, whichever is greater	Outer duct diameter plus 2½-inches
Post-Tensioned I-Girder and U-Girder Bridges ² (See <i>SDG</i> Figure 4.5.3-2)	Outer duct diameter plus 1.5 times maximum aggregate size, or outer duct diameter plus 2-inches, whichever is greater (measured along the slope of webs or flanges).	Outer duct diameter plus 2½-inches
C.I.P. Solid or Voided Slab Bridges and C.I.P. Multi-Cell Bridges (See <i>SDG</i> Figure 4.5.3-3)	Outer duct diameter plus 1.5 times maximum aggregate size, or outer duct diameter plus 2-inches, whichever is greater.	Outer duct diameter plus 3-inches.
Integral Pier Caps (See <i>SDG</i> Figure 3.11.1-1)	See <i>SDG</i> Table 3.11.1-2	See <i>SDG</i> Table 3.11.1-2

1. Bundled ducts are not allowed.
2. Detail draped tendons in post-tensioned I-Girders and U-Girders utilizing round ducts only.

Figure 4.5.3-1 Section Through Segmental Box Girder Showing Duct Spacings

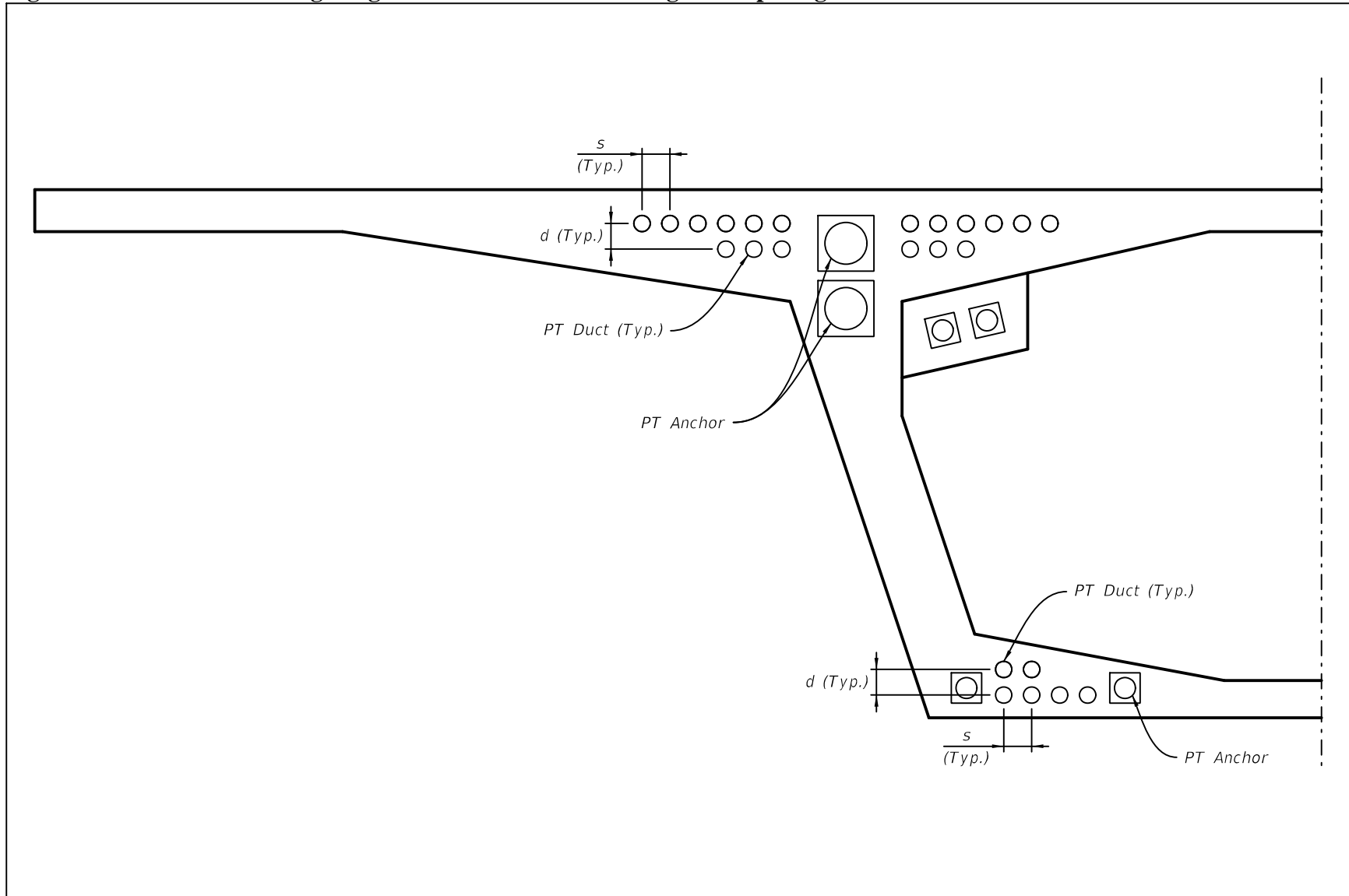

Figure 4.5.3-2 Section Through Post-Tensioned I-Girder Showing Duct Spacings

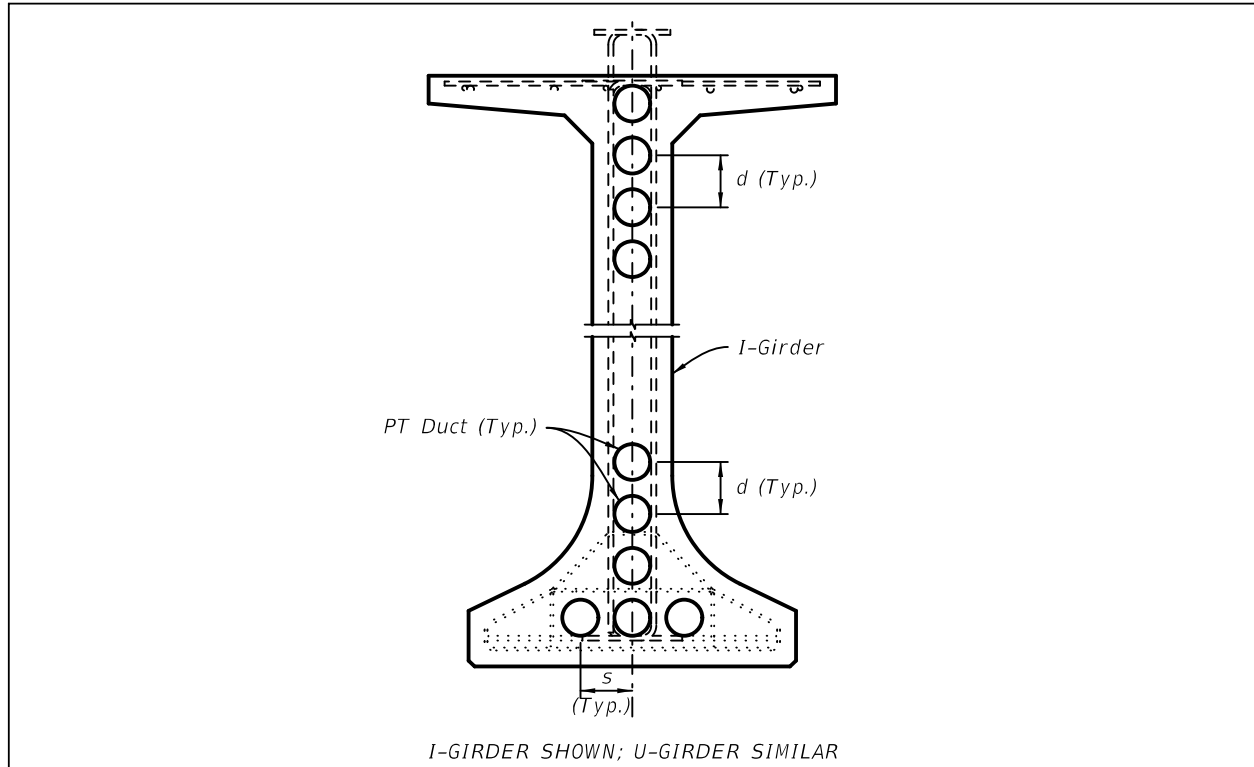
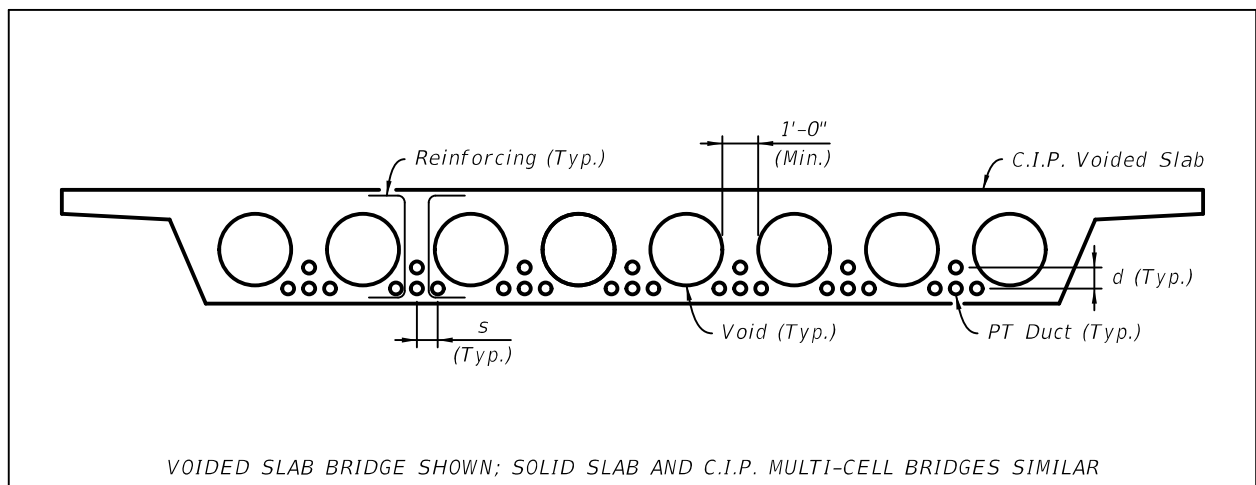

Figure 4.5.3-3 Section Through Slab or Multi-Cell Box Girder Bridge Showing Duct Spacings



9. Add the following to *Structures Design Guidelines* Section 4.6.4:
 - F. Design and detail clearance at anchorages for future inspection and replacement of unbonded tendons. See *SDG* 1.11.1.B for clearance requirements at anchorages.

10. Add the following to *Structures Design Guidelines* Section 4.7:

D. Design and detail clearance at anchorages for future inspection and replacement of unbonded tendons. See *SDG* 1.11.1.B for clearance requirements at anchorages.

11. Add the following to *Structures Design Guidelines* Section 4.8:

B. Design and detail clearance at anchorages for future inspection and replacement of unbonded tendons. See *SDG* 1.11.1.B for clearance requirements at anchorages.

12. Add the following to *Structures Design Guidelines* Section 7.3.7:

H. Obtain prior approval from the SDO to widen an existing post-tensioned bridge which has bonded (grouted) tendons with a new section of bridge which will have unbonded tendons (tendons with flexible filler).

Modification for Non-Conventional Projects:

Delete *SDG* 7.3.7.H and see the RFP for requirements.

Commentary: The structural behavior of components with bonded post-tensioning differs from that of components with unbonded post-tensioning and must be accounted for in the design of a widening.

13. Add the following new section to *Structures Design Guidelines* Chapter 11:

11.7 Temporary Access and Lifting Holes in Top Slabs of Segmental Box Girders

11.7.1 Temporary Access Holes

Temporary access holes in the top slab of segmental box girders to facilitate access for erection, jacking and tendon filling operations are permitted using the following criteria.

A. The maximum number and associated temporary access hole sizes are:

1. One 30" x 42" (maximum) temporary access hole per span, or
2. Two 12" x 12" (maximum) temporary access holes per span.

Access hole dimensions are measured at the top of the top slab.

B. Locate top slab temporary access holes within the positive moment sections of the completed structure.

C. Locate the top edges of top slab temporary access holes:

1. A minimum of 1'-0" from adjacent ducts or anchorages for longitudinal tendons in the top slab
2. A minimum of 3" from adjacent ducts and a minimum of 1'-0" from adjacent anchorages for transverse tendons in the top slab
3. A minimum of 1'-0" measured horizontally from anchorages in the bottom slab accounting for longitudinal grade and cross slope

- D. Detail the sides of temporary access holes to be sloped at 1H:6V.
- E. Utilize threaded reinforcing bar couplers/inserts for bars that must be cut and made discontinuous at the temporary access holes. Do not show cut reinforcing bars to extend into temporary access holes and be bent out of the way temporarily to facilitate access.
- F. Provide supplemental reinforcing bars placed parallel to each side and diagonally at each corner of temporary access holes.
- G. Specify temporary access holes to be filled in accordance with Specification 462.

11.7.2 Lifting Holes

Round lifting holes in the top slab of segmental box girder segments are permitted using the following criteria.

- A. Utilize through holes in lieu of embedded anchor assemblies.
- B. Design and detail lifting holes to have a constant maximum diameter of 2" or to have sloping sides with a 2" maximum diameter.
- C. Locate lifting holes a minimum of 1" from adjacent ducts and a minimum of 1'-0" from adjacent anchorages.
- D. Specify the use of removable forming devices and materials, and that they are to be removed prior to filling lifting holes.
- E. Specify lifting holes to be filled in accordance with Specification 462.

14. Replace *Structures Detailing Manual* Section 20.8 with the following:

20.8 Superstructure Drawings - Post-Tensioning Details

- A. The Post-Tensioning Details Sheet(s) incorporate all of the post-tensioning details to describe the overall geometry of the tendons not otherwise shown on other sheets. The Post-Tensioning Details Sheet(s) show the detailed PC and PT of the tendons, tendon radius/parabolic profile (plan and elevation), and anchorage location for all permanent and temporary strand and bar tendons.
- B. Provide clearances at Stressing End Anchorage locations as shown in Figure 20.8-1 and Figure 20.8-2. Provide clearances at Non-stressing End Anchorage locations as shown in Figure 20.8-3 and Figure 20.8-4.
- C. Design and detail external tendons at diaphragms, deviators and blisters as shown in Figures 20-8.5 through 20.8-10. See *SDG* 1.11.4 for additional requirements.

Figure 20.8-1 Stressing End Anchorage Clearance of Bottom Internal Tendon Near Deviator

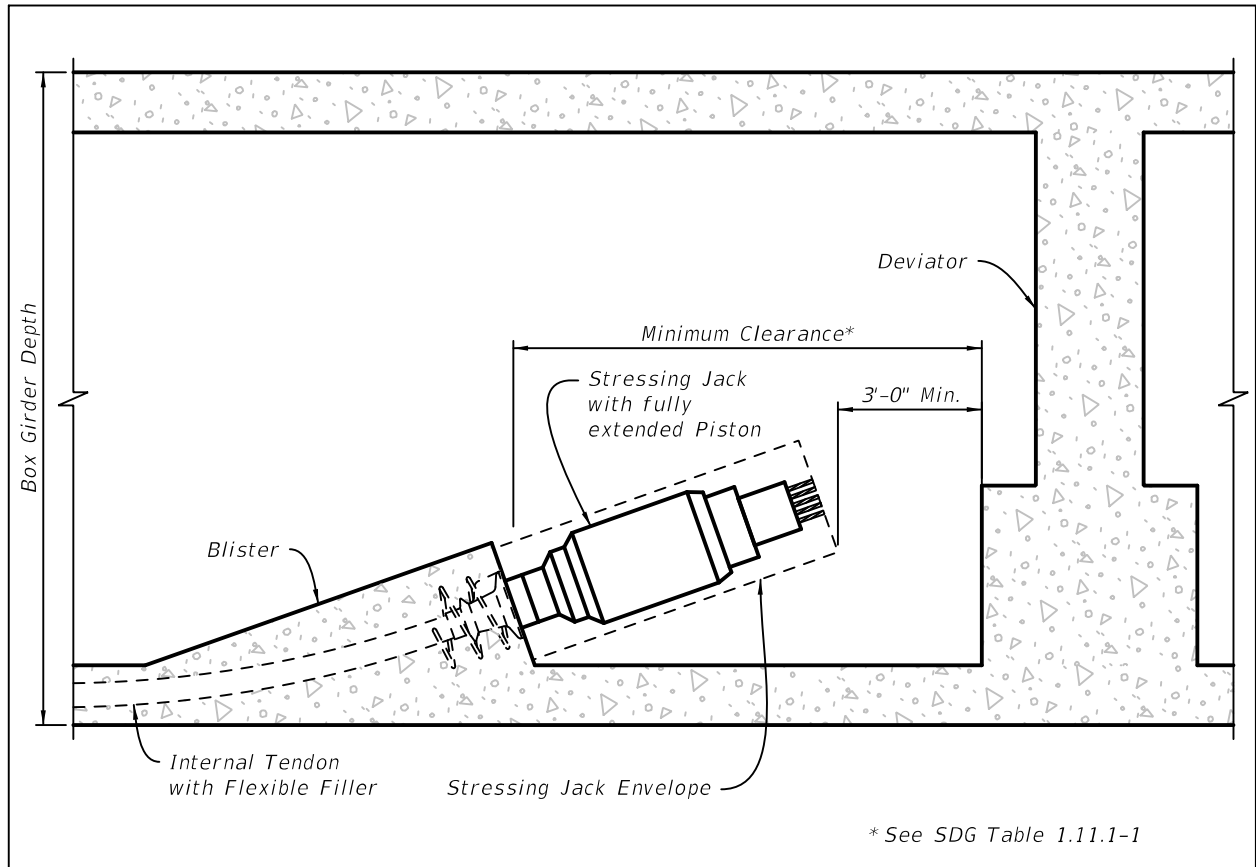

Figure 20.8-2 Stressing End Anchorage Clearance of External Tendon at Diaphragm Near Anchor Block

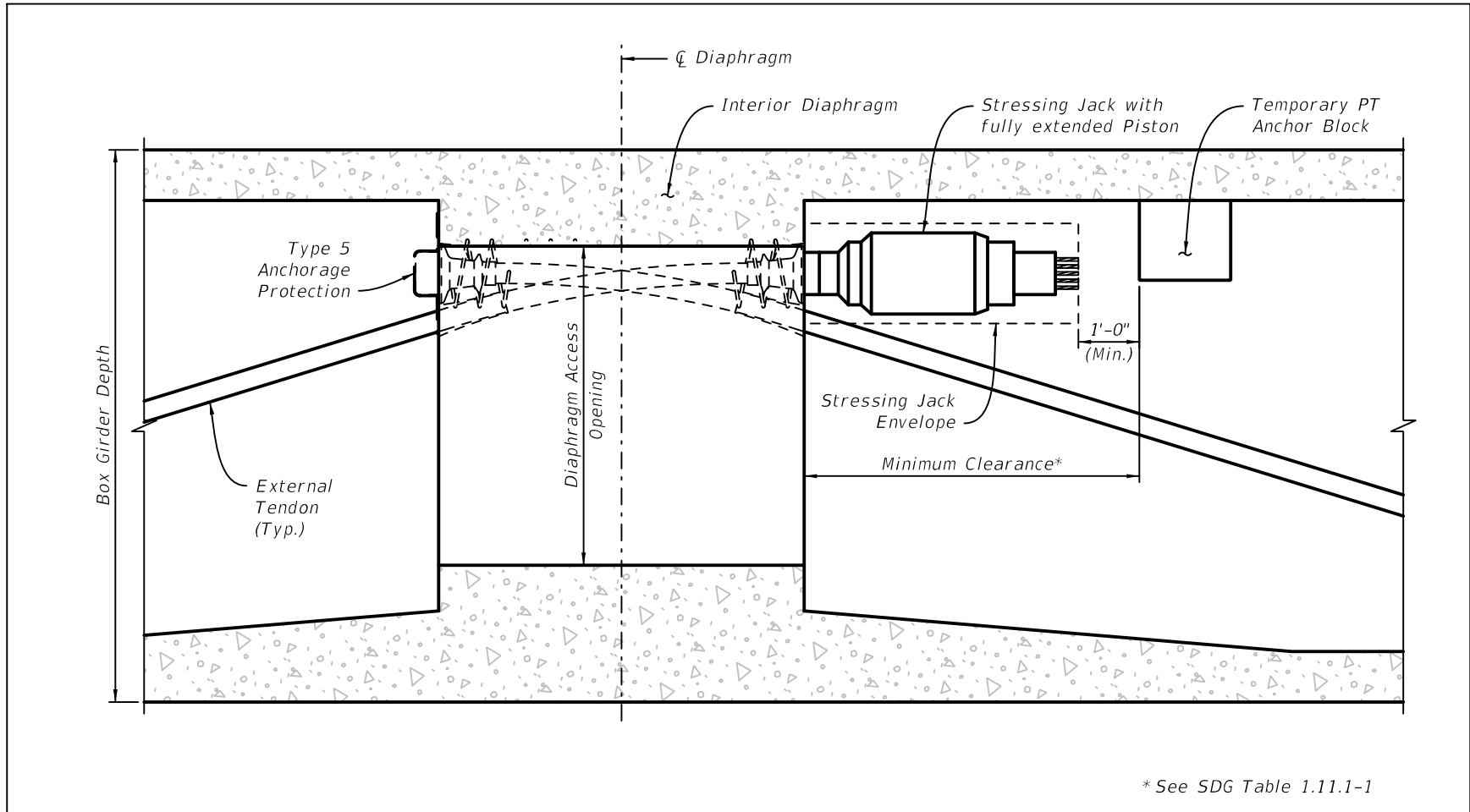

Figure 20.8-3 Non-Stressing End Anchorage Clearance at End Diaphragm Near Abutment Backwall

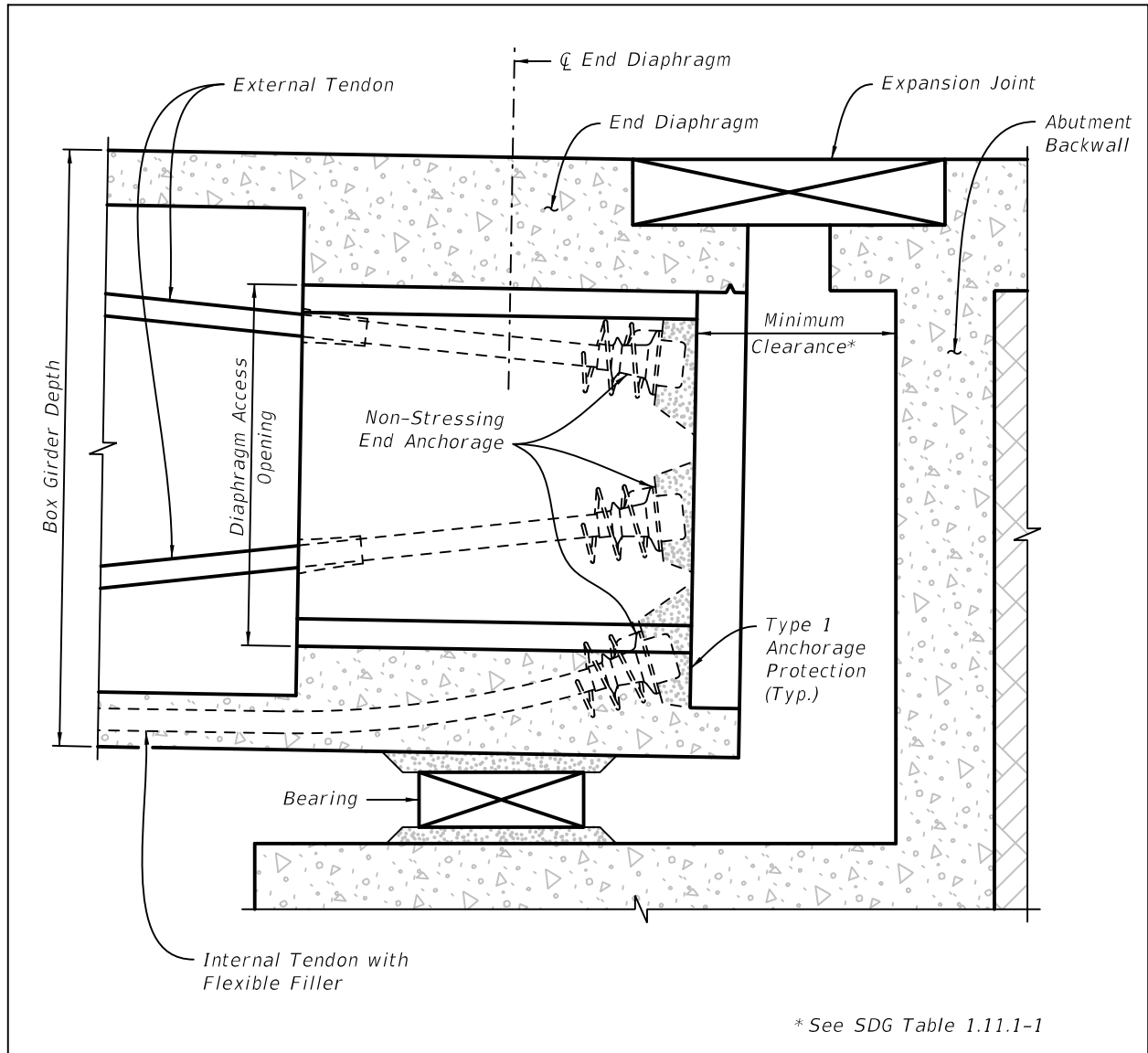

Figure 20.8-4 Non-Stressing End Anchorage Clearance at End Diaphragm Near Other Structure

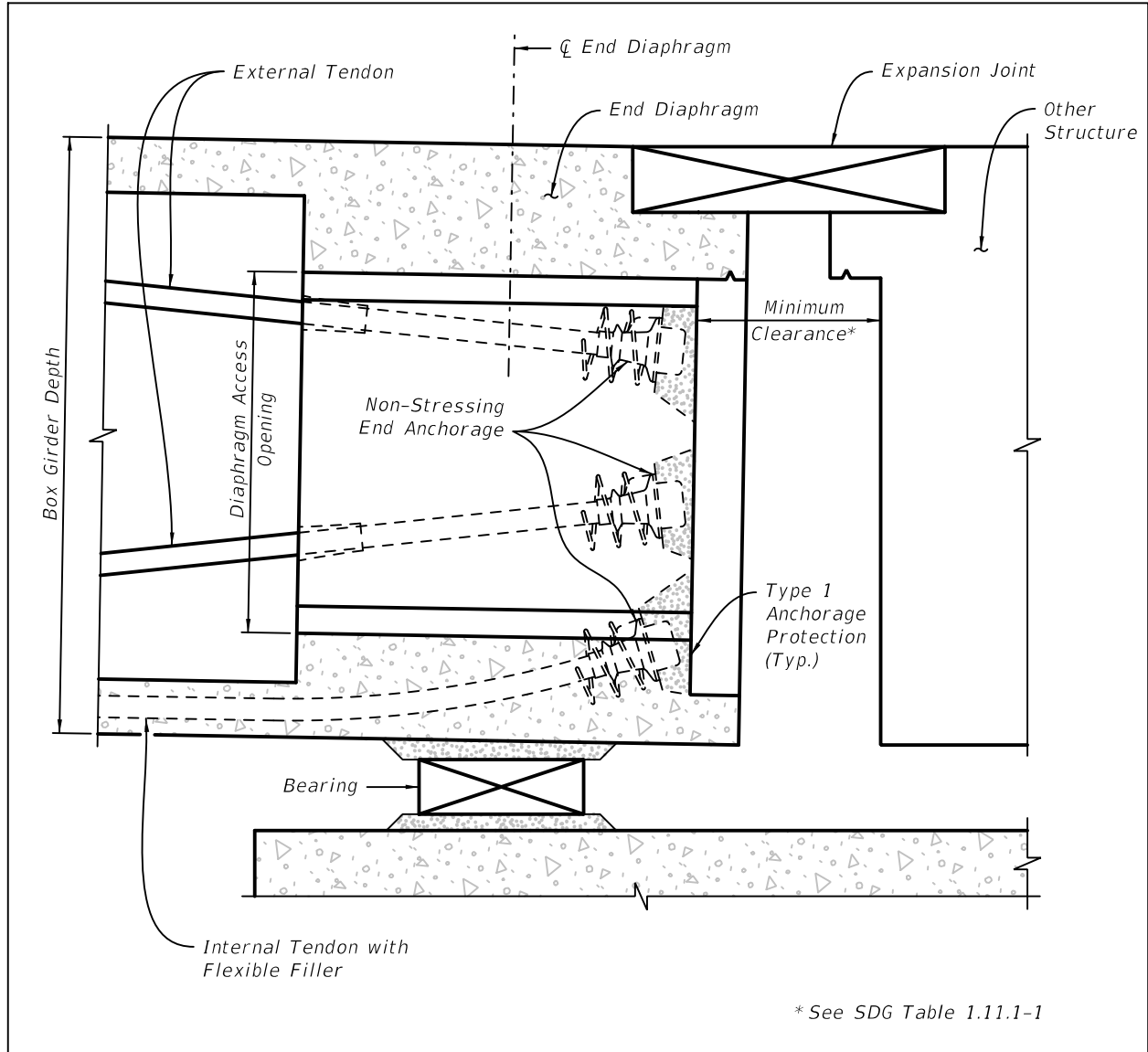

Figure 20.8-5 Detail at Pier Segment with Tendon Anchorage

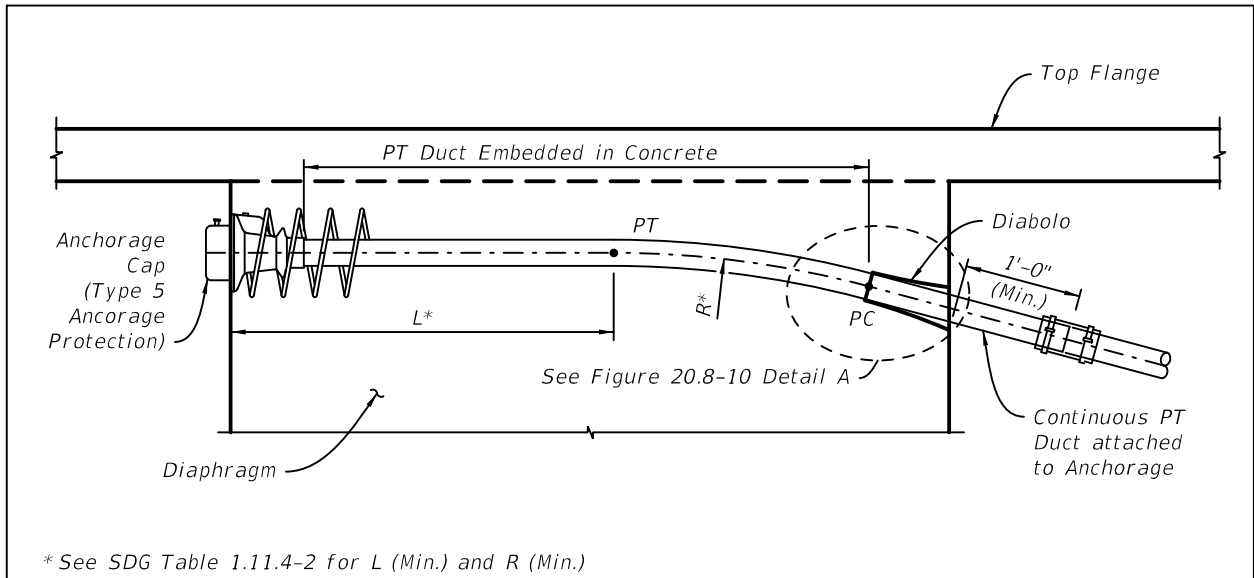

Figure 20.8-6 Detail at Expansion Joint Segment with Tendon Anchorage

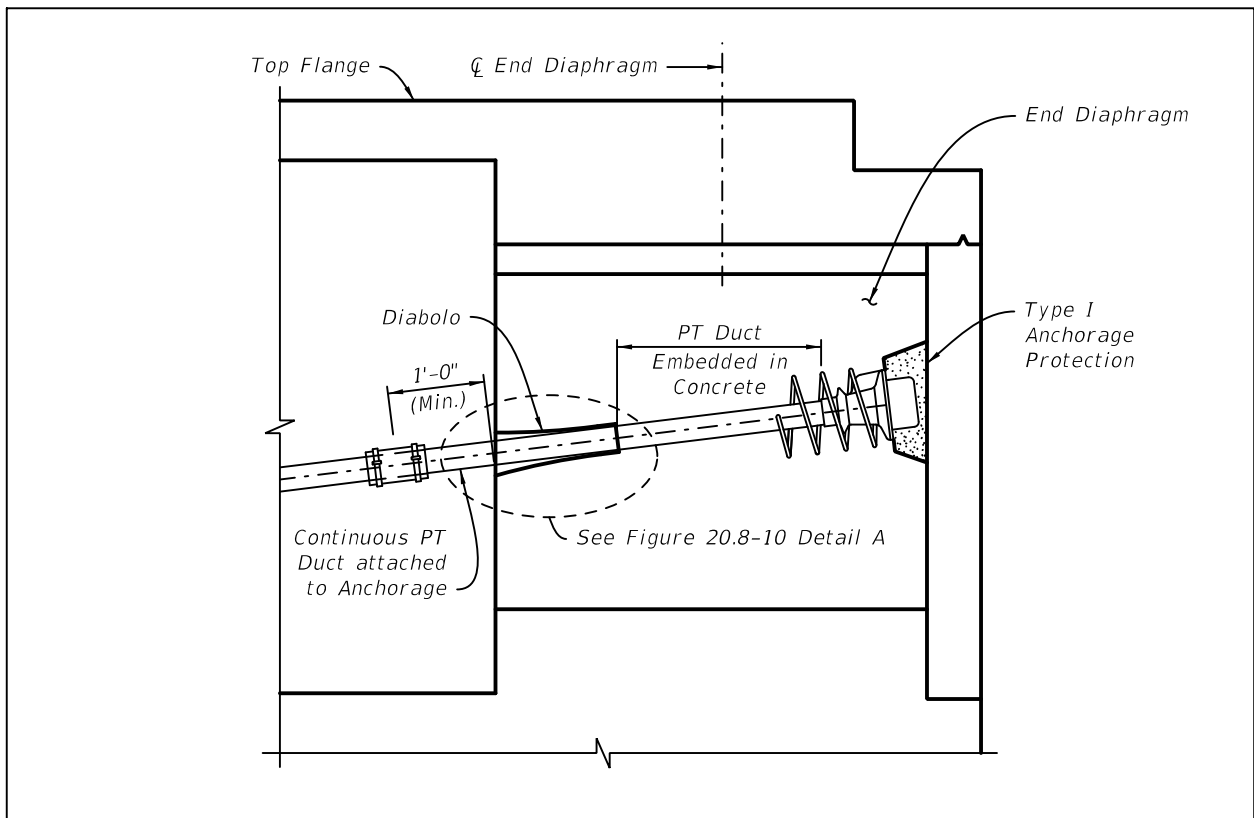

Figure 20.8-7 Detail at Blister without Anchorage

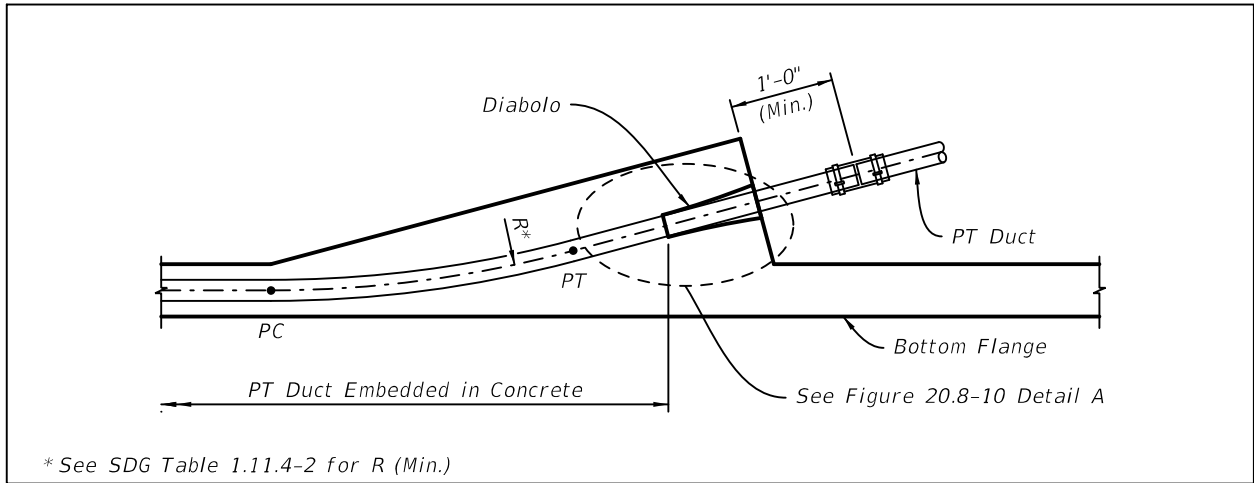

Figure 20.8-8 Detail at Pier Segment with Tendon Saddle

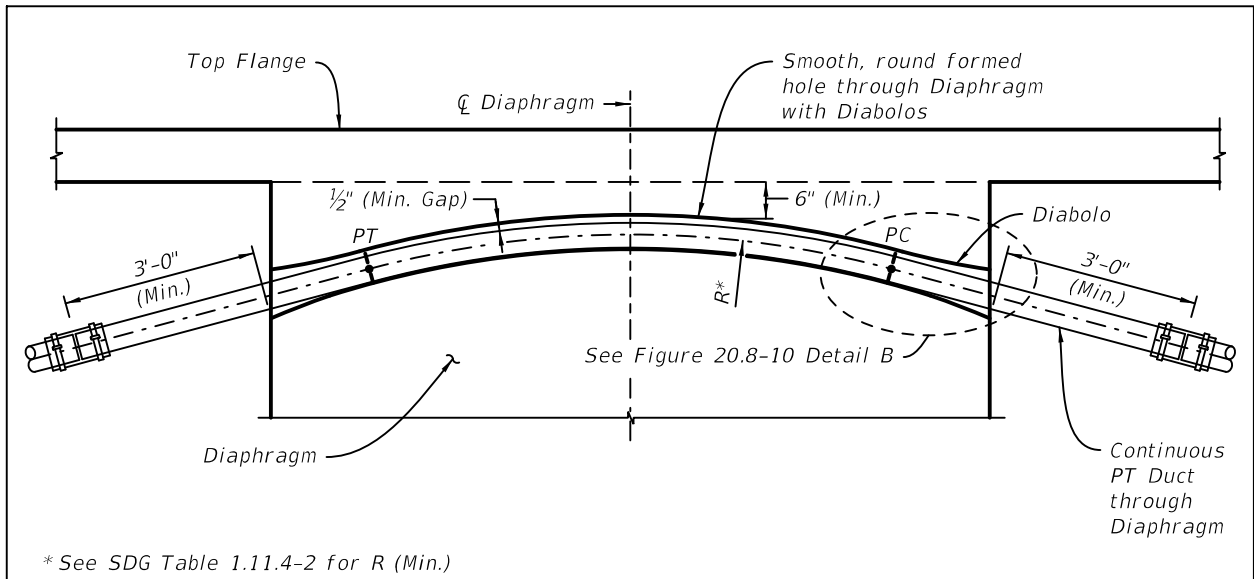

Figure 20.8-9 Detail at Deviator

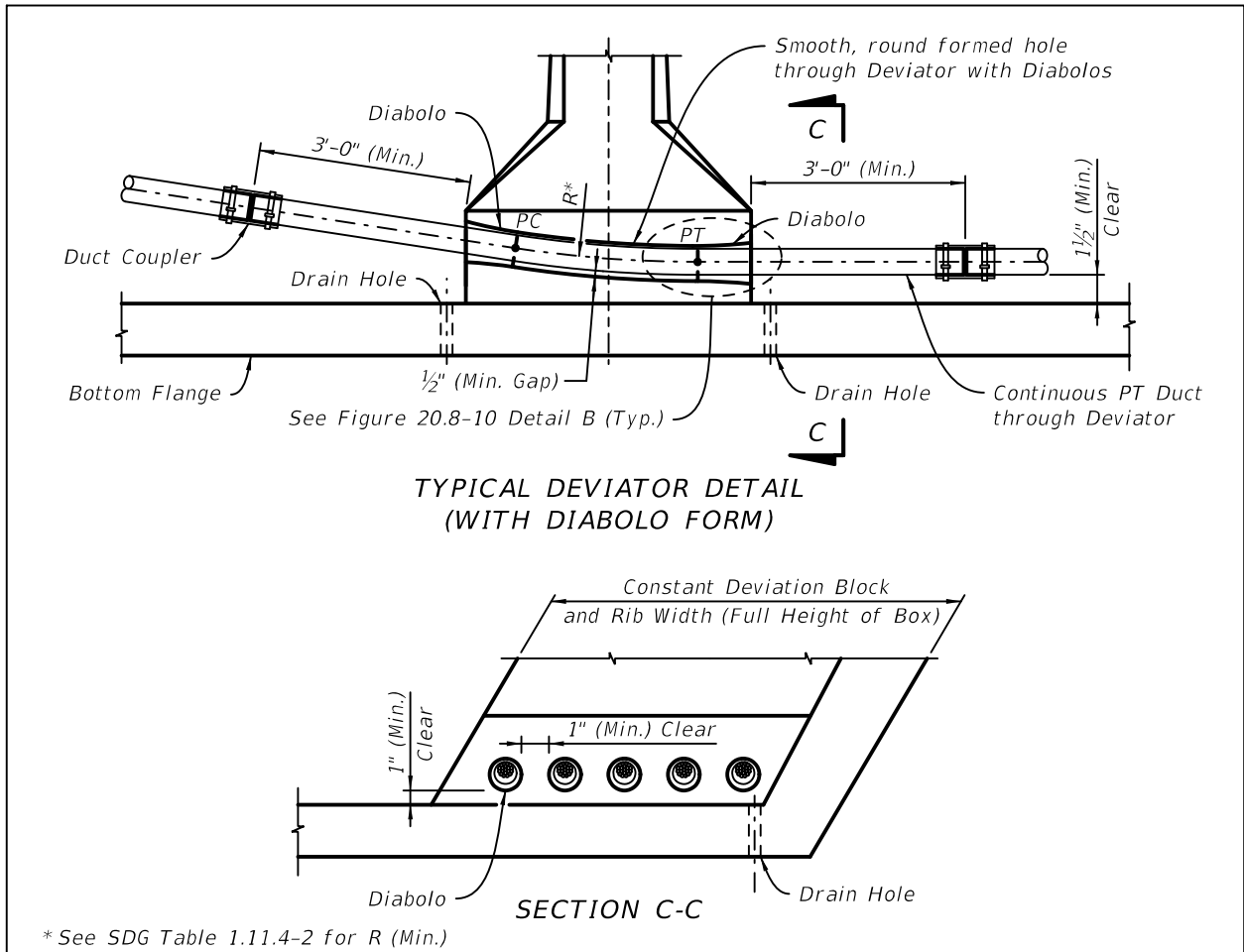
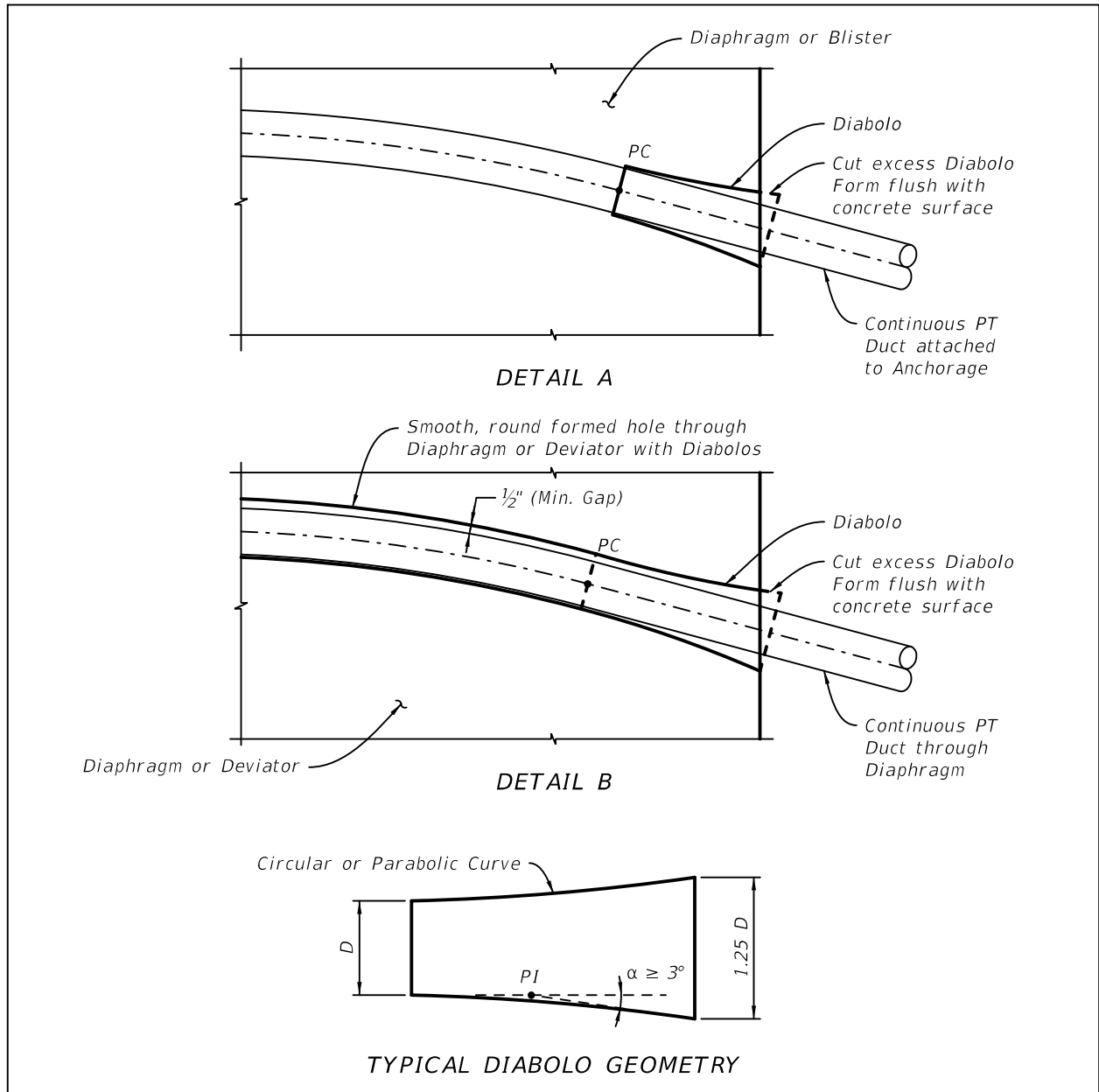

Figure 20.8-10 Diabolo Details



15. Replace *Structures Detailing Manual* Section 23.7.C with the following:

C. Detail Anchorage locations as shown in Figure 23.7-1, Figure 23.7-2, Figure 23.7-3, and Figure 23.7-4. Provide clearances at Non-stressing End Anchorage locations as shown in Figure 23.7-3 and Figure 23.7-4.

16. Replace *Structures Detailing Manual* Figure 23.7-1 and Figure 23.7-2 with the following and add Figures 23.7.3 and 23.7.4:

Figure 23.7-1 Post-Tensioned Spliced Girder Details (1 of 4)

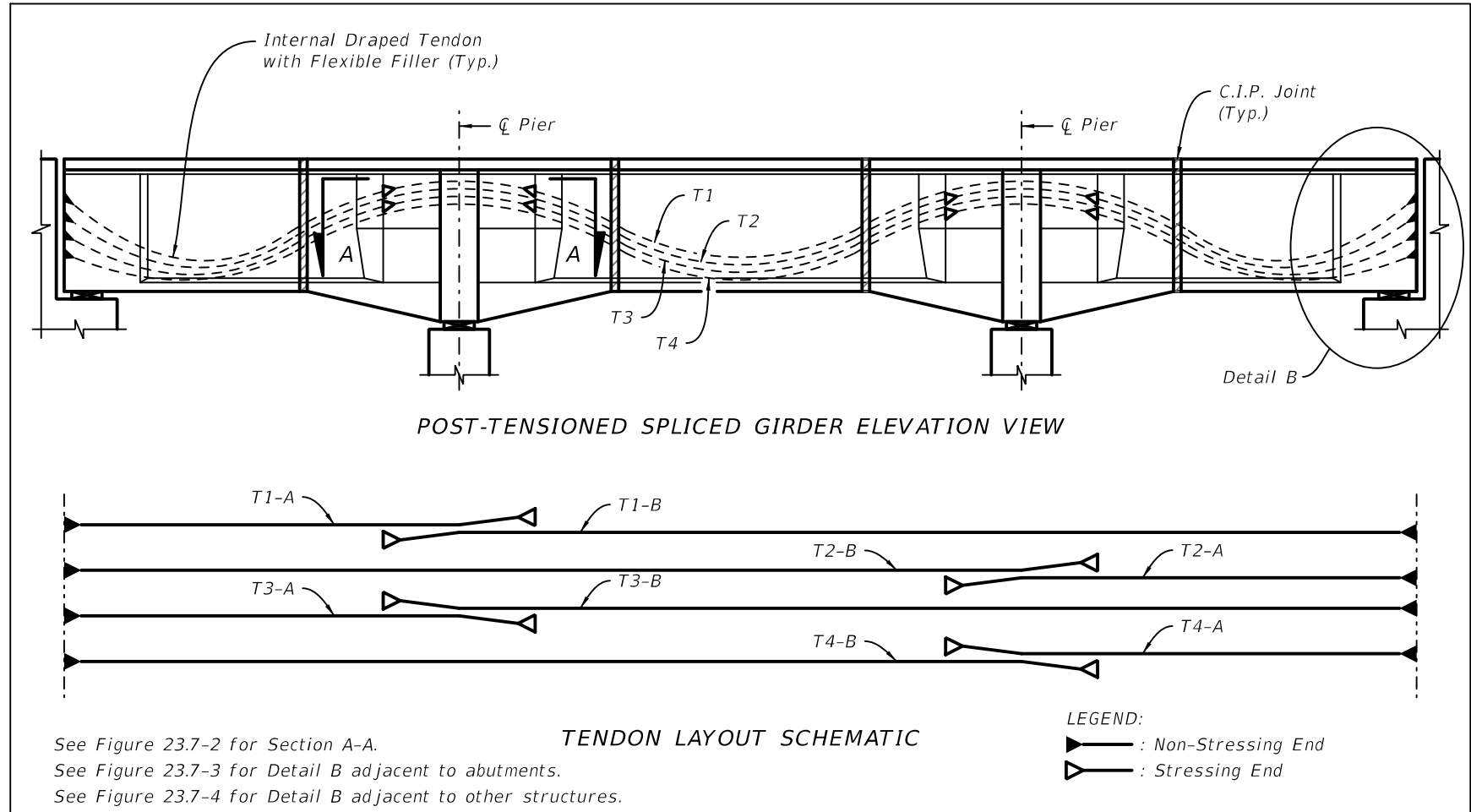

Figure 23.7-2 Post-Tensioned Spliced Girder Details (2 of 4)

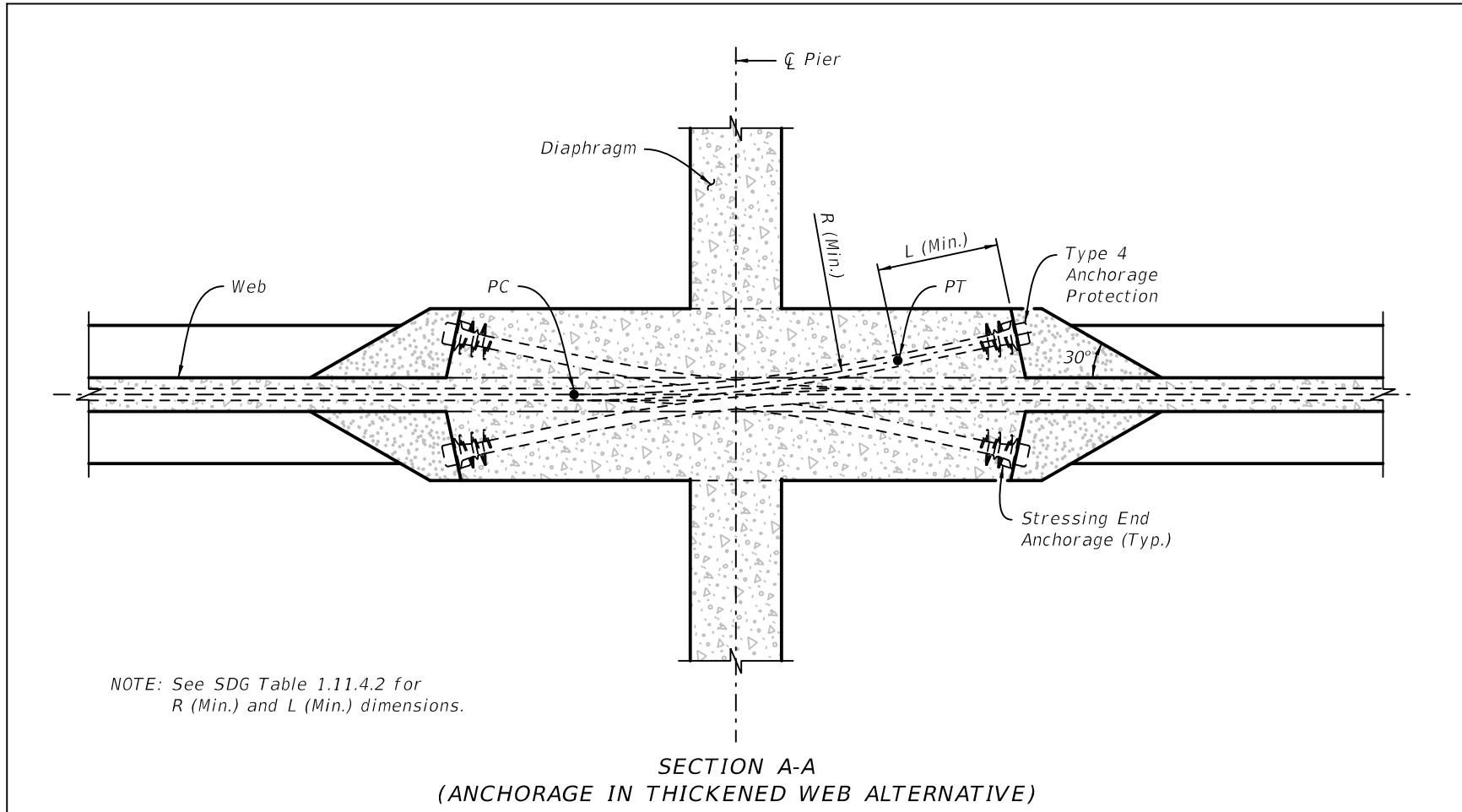

Figure 23.7-3 Post-Tensioned Spliced Girder Details (3 of 4)

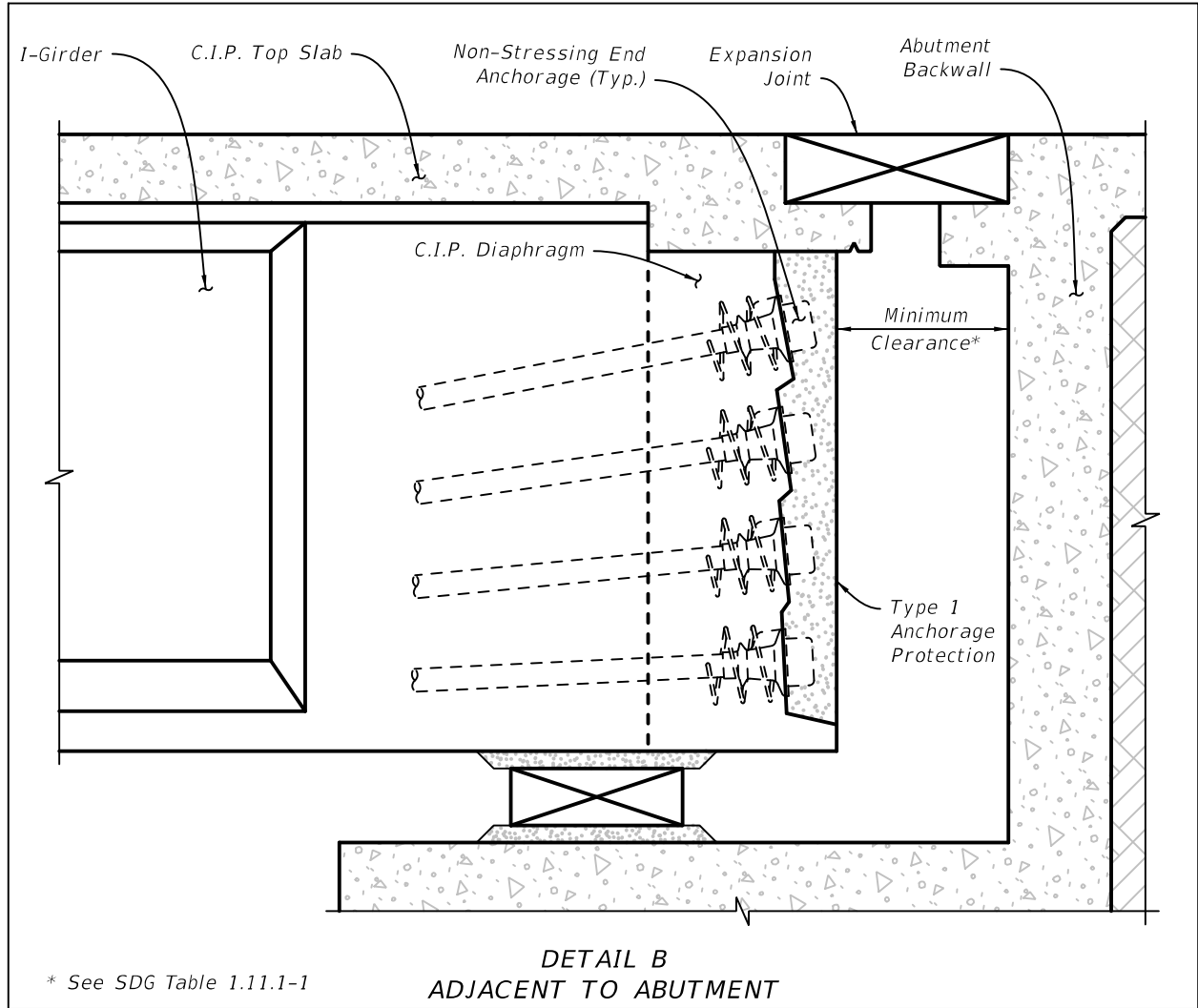
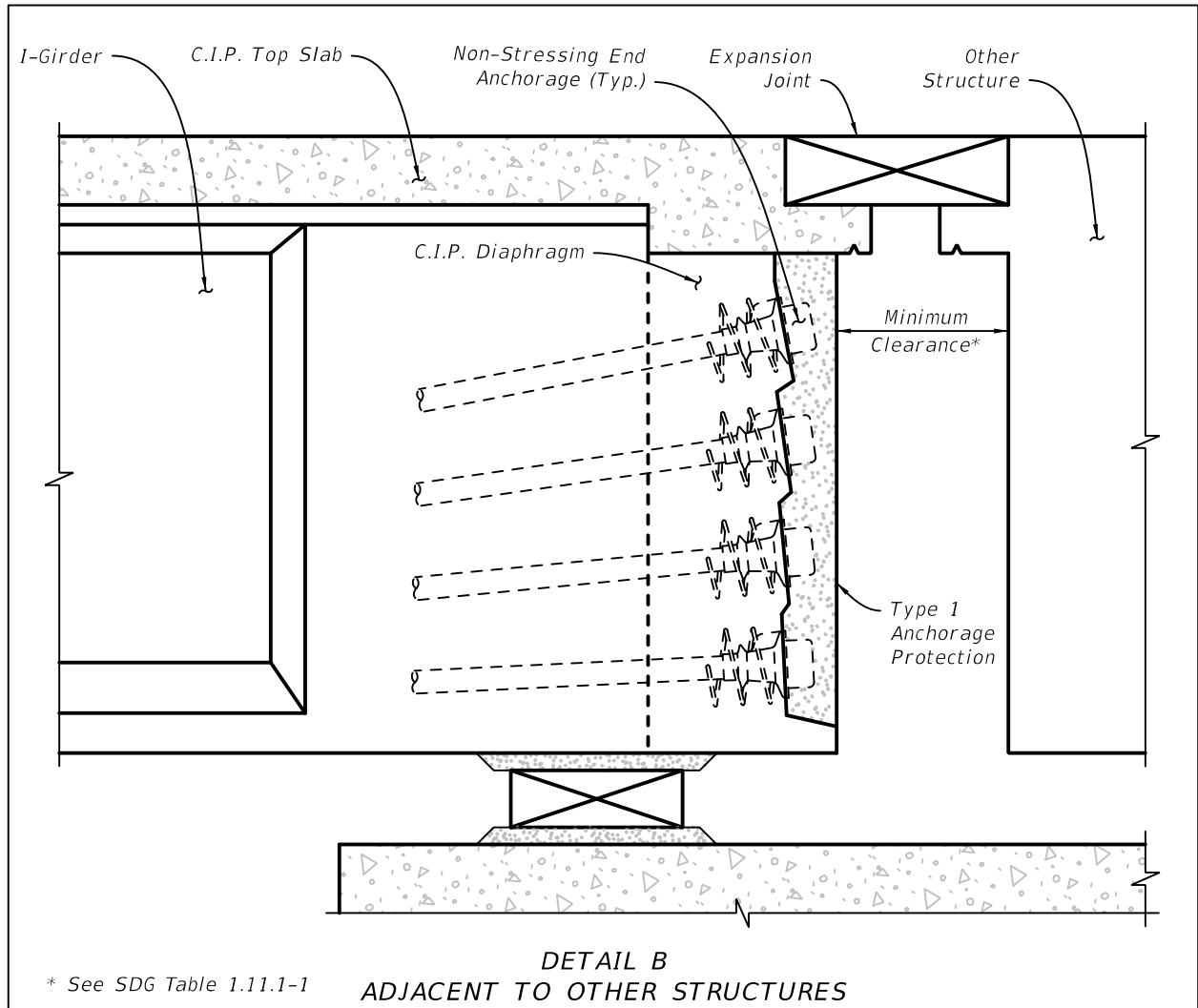

Figure 23.7-4 Post-Tensioned Spliced Girder Details (4 of 4)



17. Revisions to **Design Standards** Indexes 21801, 21802 and 21803 associated with replaceable tendons have been released as **Design Standards Revisions (DSR)** in the **FY 2016-2017 Design Standards eBook**. An update to the **Instructions for Design Standards** Index 21800 Series has also been released with the **DSR**. These revisions can be found at:
<http://www.dot.state.fl.us/rddesign/DesignStandards/Standards.shtm>.

18. Revisions to **Specifications** 105, 462 and 960 will be included in the January 2017 Workbook. These revisions can be seen at:
<http://www.dot.state.fl.us/programmanagement/Implemented/WorkBooks/History/Jan17/Default.shtm>

COMMENTARY

Current criteria in *Structures Design Guidelines* 1.11.1.B requires post-tensioning strand and wire tendons that utilize flexible filler to be replaceable. The revisions to the *Structures Manual* and the *Design Standards* included in this bulletin are intended to clarify design criteria and provide conceptual details for replaceable tendons.

BACKGROUND

Flexible filler is one of the components in the strategy to provide durable post-tensioned bridges and is intended to provide corrosion protection of PT tendons for a structure's design life. A benefit of flexible filler is replaceability of tendons during the service life of a structure, besides providing a robust corrosion protection. Design criteria and details for unbonded post-tensioning tendons have been revised and added in the Structures Manual and Design Standards to facilitate access for inspection, maintenance and replacement of critical tendons, and to minimize disruption to Florida's transportation system.

IMPLEMENTATION

The requirements of this bulletin are effective on design-bid-build projects at 30% plans or less as of the date of this bulletin.

This bulletin is effective immediately on all design-build projects for which the final RFP has not been released.

CONTACT

Charles E. Boyd, P.E.
Assistant State Structures Design Engineer
Phone (850)-414-4275
charles.boyd@dot.state.fl.us

RVR/CEB/TST