

Florida

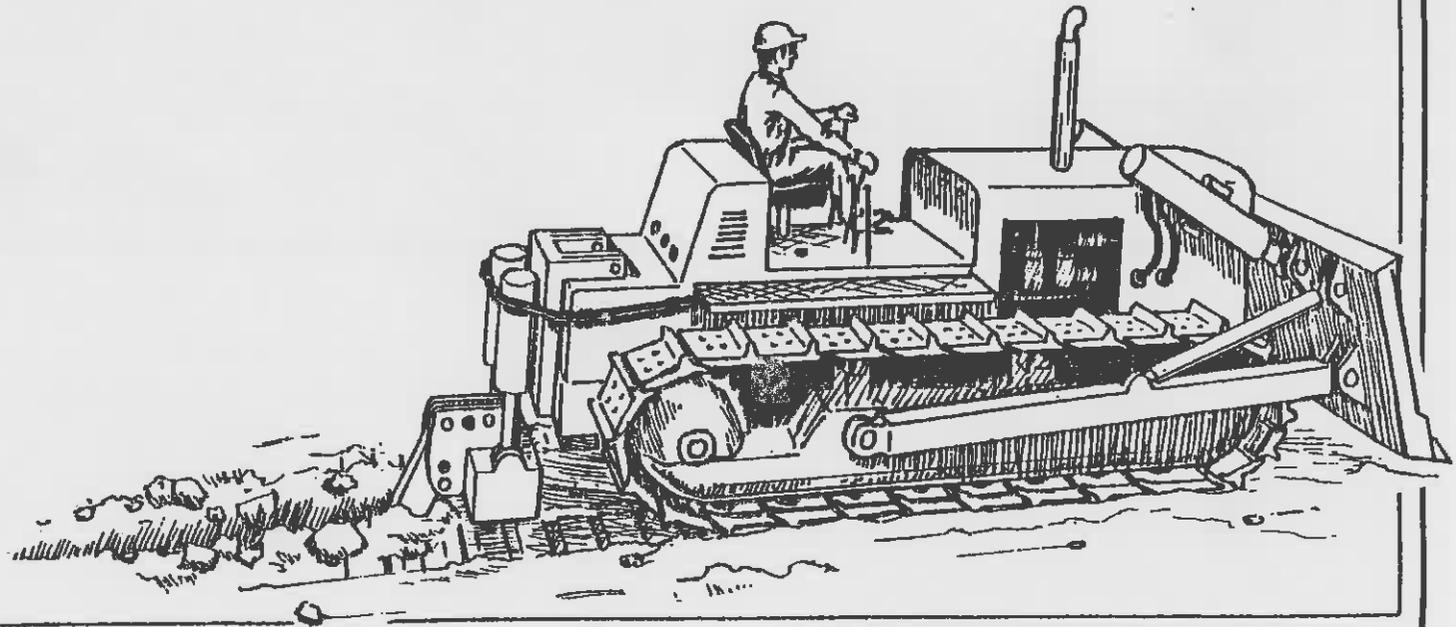

Department of Transportation

UTILITY RELOCATION, CLEARING AND GRUBBING, AND MISCELLANEOUS CONCRETE STRUCTURES INSPECTION



UTILITY RELOCATION, CLEARING AND GRUBBING AND MISCELLANEOUS CONCRETE STRUCTURES INSPECTION

a training course developed

by the

FLORIDA DEPARTMENT OF TRANSPORTATION



**This 2000 revision was carried out under the direction of
Lewis Harper, Pre-qualification Engineer**

**Office of Construction
Florida Department of Transportation**

**Douglas Townes, State Construction Training Engineer
Yvonne Collins, State Construction Training Coordinator**

FOREWORD

Utility Relocation, Clearing and Grubbing and Miscellaneous Concrete Structure Inspection is a training course that covers the activities to ensure proper field inspection of utility relocation and clearing and grubbing operations and the construction of miscellaneous structures. The major areas covered in the first part of this course include:

- ▶ a review of plan sheet, symbols and abbreviation;
- ▶ the responsibilities of Department, Contractor and Utility personnel;
- ▶ field inspection of utility adjustments;
- ▶ field inspection of cleaning and grubbing operations; and
- ▶ documentation.

The second part of the course covers the activities required to inspect the construction of:

- ▶ barrier wall,
- ▶ curb and gutter,
- ▶ traffic separator,
- ▶ sidewalk,
- ▶ ditch pavement, and
- ▶ slope pavement.

All of the above areas are discussed in terms of the Inspector=s responsibilities, but it should not be taken to mean that only one person will perform all the activities. Staffing may vary according to project size and other factors, but each Inspector should be able to do every work activity. All metric conversions are hard conversions.

TABLE OF CONTENTS

Foreword	I
Directions to Course Users	iii
Chapter One: GENERAL INFORMATION FOR UTILITY RELOCATION AND CLEARING AND GRUBBING	1-1
Chapter Two: UTILITY RELOCATION INSPECTION	2-1
Chapter Three: CLEANING AND GRUBBING INSPECTION	3-1
Chapter Four: BASIC INFORMATION FOR MISCELLANEOUS CONCRETE STRUCTURES	4-1
Chapter Five: BARRIER WALL	5-1
Chapter Six: CURB AND GUTTER	6-1
Chapter Seven: TRAFFIC SEPARATOR	7-1
Chapter Eight: CONCRETE SIDEWALK	8-1
Chapter Nine: DITCH PAVEMENT	9-1
Chapter Ten: SLOPE PAVEMENT	10-1
Chapter Eleven: REVIEW QUIZ	11-1
Appendix: PLAN BOOK	A-1
SUBJECT INDEX	

DIRECTIONS TO COURSE USERS

TRAINING TECHNIQUE

This course has been designed for self-instructional training.

1. You can work alone.
2. You can make as many mistakes as are necessary for learning -- and correct your own mistakes.
3. You can finish the training at your own speed.

You will keep this book as your reference, so work neatly.

It will be necessary for you to use the Contract Plan Reading Plan Book.

PREREQUISITES

The Department Construction Training Policy requires that you take two courses within the first year of your employment: Construction Mathematics and Contract Plan Reading. For this course you will need both. In addition, you should have completed Earthwork Inspection or know the subject matter thoroughly.

HOW TO USE THIS BOOK

This is not an ordinary book. You cannot read it from page to page as you do other books. This book gives you some information and then asks a series of questions about that information. The questions are asked in such a way that you will have to think carefully and draw some conclusions for yourself. If you have difficulty in answering the questions, review the sections that give you trouble before going on.

The answers to the questions are in the back of the chapters.

EXAMINATION

An Examination has been developed for this course.

The Examination contains questions and problems only -- and no answers. To help you prepare for the Examination, a Review Quiz is included at the end of this course. If you have no difficulty with the Review Quiz, the Examination should present no problems.

CHAPTER ONE

General Information for Utility Relocation and Clearing and Grubbing

CONTENTS

GENERAL INFORMATION	1-2
UTILITY RELOCATION	1-3
Definition	1-3
Sequence	1-4
Plan and Profile Sheets	1-5
Utility Adjustment Sheets	1-5
Utility Symbols	1-6
Inspection Responsibilities	1-6
CLEARING AND GRUBBING	1-9
Definition	1-9
Sequence	1-11
Plan and Profile Sheets	1-11
Clearing and Grubbing Sheet	1-12
ANSWERS TO QUESTIONS	1-16

GENERAL INFORMATION FOR UTILITY RELOCATION AND CLEARING AND GRUBBING

INTRODUCTION

The first chapter will be short. It will review some of the things you covered in the Contract Plan Reading Course. It will be necessary for you to use the Contract Plan Book for this chapter, so be sure you have it nearby before you start. We will define utility relocation and clearing and grubbing and we will look at plan sheets, symbols and abbreviations that are important in your work.

So let's start at the beginning - what do we mean by utility relocation?

UTILITY RELOCATION

DEFINITION

When utilities (overhead, surface and underground facilities) exist within the right-of-way (R/W) of a construction project, there are several things that can happen to them:

1. If they do not conflict with construction, they can be left in place.
2. If vertical clearance is the only problem, they can be adjusted (raised or lowered) in place.
3. They may be relocated within the R/W.
4. They may be relocated outside the R/W.
5. They may be abandoned and removed.
6. They may be abandoned and left in place.

All of these situations come under the heading of utility work but Item Nos. 2, 3, and 4 come under the heading of Utility Relocation . Utilities that are abandoned are included in the clearing and grubbing work or are left in place. If they are to be abandoned, the information will be shown on the plans.

On primary and secondary road project, underground utilities must be a minimum 36 inches (0.9m) under pavement and 30 inches (0.8m) under unpaved ground below finished grade. On interstate highway and expressways, the minimum cover below finished grade is 48 inches (1.2m).

Obviously, when utilities are left in place. Your duties as an Inspector will be less than when utilities are relocated. This course will cover both cases.

SEQUENCE

Before the actual grading operation begins, the area within the R/w must be prepared - utilities must be removed, relocated, or protected and trees, underbrush, debris and other obstructions must be removed.

In some cases, all or most of the utilities will be relocated before any other work begins. In these cases you will have few inspection duties. Where construction work overlaps relocations, you will have more important duties.

In either case, you must know the contract plan requirements. The plans provide the information you need to do your job. Do you know how to read the plans? The next few pages should help to refresh your memory.

PLAN AND PROFILE SHEETS

Who is responsible for adjusting or moving utilities? In most cases, the responsibility lies with the owner of the utility. Special notes that appear on the first plan and profile sheets of the contract plans usually will specifically identify the party responsible for each utility. In a few cases, the Contractor will be responsible for the adjustment or removal. In any case, the contract plans will hold the answer and Special Provisions will give the details.

UTILITY ADJUSTMENT SHEETS

Certain public utilities - such as power lines, telephone lines, water lines, sewer lines and gas lines - must be relocated inside or outside the project R/W. Your concern is where these utilities are located and where they are to be moved.

First, let's find out where the utilities are located. Utilities are shown as symbols on utility adjustment sheets. Utility adjustment sheets are the main source of information on utility relocations. They show plan views - and some profile views - of existing and proposed utilities. Unlike plan and profile sheets, utility adjustment sheets usually do not show a continuous view of the project. Instead, only the segments affected by utility relocation are shown. The segments are conveniently shown in the order of increasing stations.

UTILITY SYMBOLS

Many utility symbols are used on utility adjustment sheets. If you are not familiar with them, review Standard Index 002 in the Contract Plan Reading Plan Book.

Here is a rule of thumb that may be helpful in interpreting the symbols. The symbol for each object is nearly the same for both the existing and the proposed object. The only difference is that existing utility symbols tend to be open (not shaded) with dashed lines; proposed utility symbols tend to be darkened (shaded) with solid lines. With this rule of thumb in mind, compare some of the symbols in the utility symbols key.

INSPECTION RESPONSIBILITIES

As an Inspector, it will be your job to know:

- ▶ WHO is responsible for removing or relocating utilities;
- ▶ WHICH utilities are being removed or located; and
- ▶ WHERE utilities are being relocated

All the answer can be found in the contract plans. The locations and relocations are shown on plan and profile sheets - it is important to know where existing utilities are and proposed future locations.

To refresh and test your memory about the plans, try the following quiz.

QUIZ

Why would utilities be left in place?

Where in the plans will you find the names of parties responsible for utility relocations?

Utility adjustment sheets usually show:

- A. a continuous view of the project.
- B. only those segments affected by relocations.
- C. segments in order of decreasing stations.

Refer to the plan sheet on the next page to answer the question below, regarding Financial Project ID 000000-00000

What utility adjustments are called for left of station 25 + 00 through 30 + 00 along State Road 59?

Who is responsible for utility relocations? _____

Name and locate the utilities that will remain between stations 15 + 00 and 30 + 00 along State Road 59.

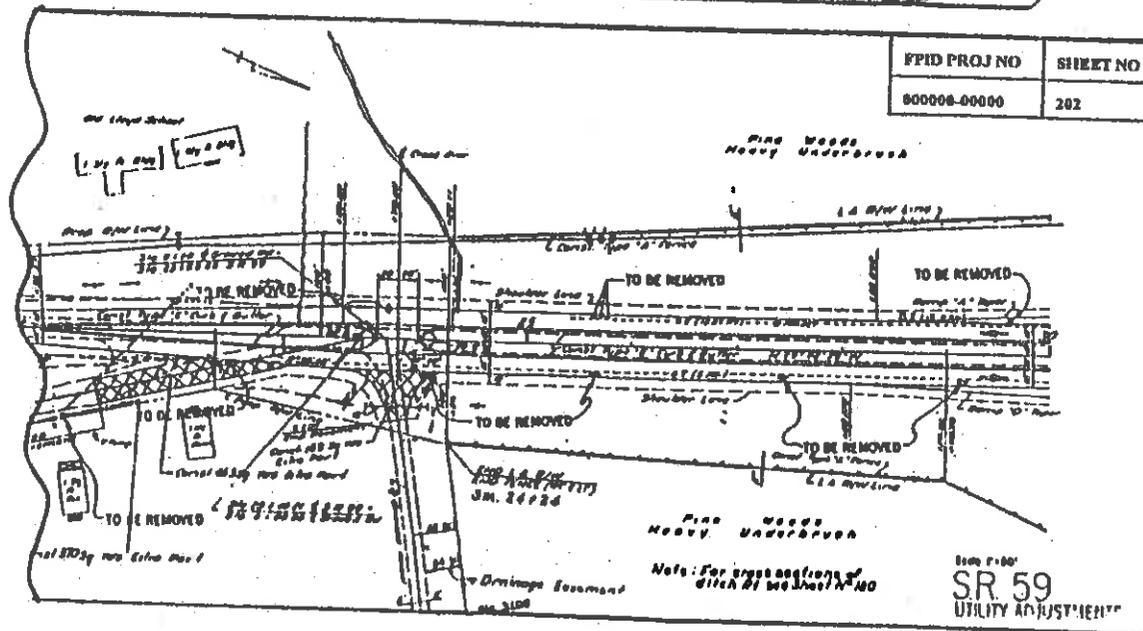
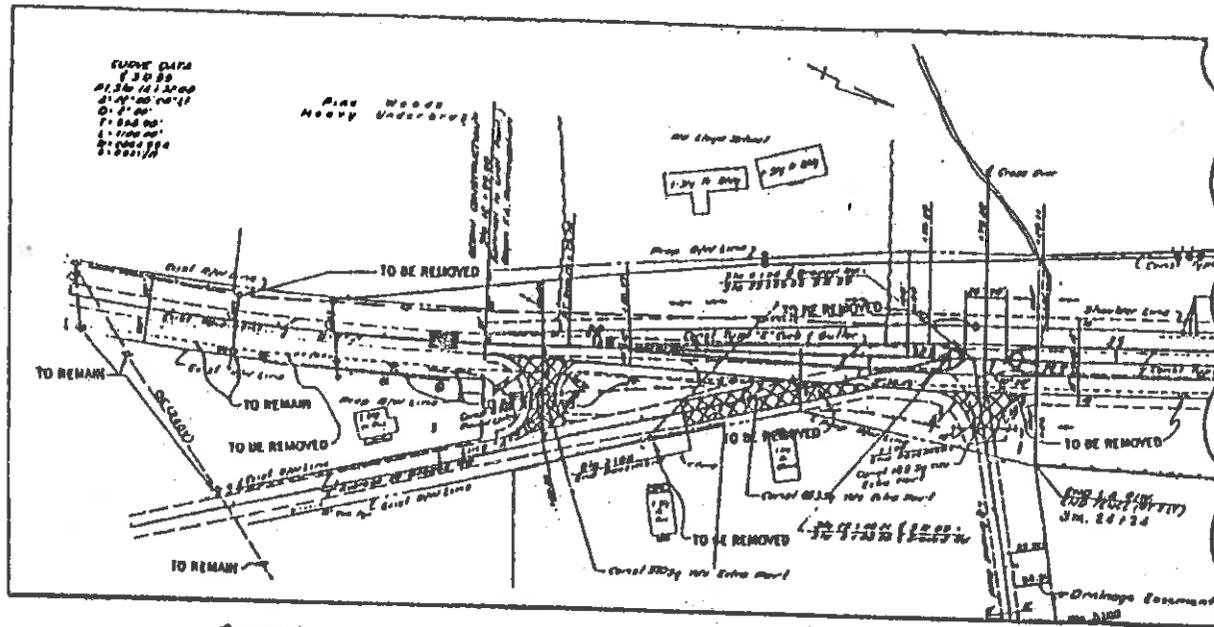

How did you do on the quiz?

As an Inspector, you must know which utilities are to be adjusted, removed, or left in place. Your key to all these is the contract plans. So it is important that you know how to read the plans. If you had any problems with the quiz, go back and study the plan book.

CLEARING AND GRUBBING

DEFINITION

Clearing and grubbing is the initial operation undertaken by the Contractor in the construction of a roadway. Clearing and grubbing is the removal and disposal of all objectionable materials - unwanted vegetation, debris and structures that are within the limits of the R/W and in borrow pits, lateral ditches, areas where structures will be built and any other areas indicated in the plans. Selective clearing and grubbing includes the preservation of tree and other vegetation, desirable for beautification and esthetics.

Generally, this the distinction between clearing and grubbing, however they are to be considered as one operation:

CLEARING - removal above the original ground.

GRUBBING - removal below the original ground.

The debris and other objectionable materials - to be removed and disposed of as indicated in the plan and in the specifications - may include the following:

- ▶ trees,
- ▶ undergrowth,
- ▶ stumps,
- ▶ underground tanks,
- ▶ rubbish,
- ▶ hedges,
- ▶ roots,
- ▶ large rocks,
- ▶ existing underground drainage facilities to be abandoned,
- ▶ any other objects in the way of construction, and
- ▶ utilities abandoned in place.

There may be separate pay items for removing obstructions such as structure and existing pavement. Otherwise, removal will be part of the clearing and grubbing work.

SEQUENCE

The Contractor will clear and grub all vegetation not designated by the Engineer to remain for aesthetic purposes. That which is designated to remain is selective clearing and grubbing. You should be aware of the arrangements that have been made to clear and grub the R/W.

PLAN AND PROFILE SHEETS

Since plan and profile sheets show existing topography, many of the items to be cleared and grubbed are shown on those sheets. The items are outlined and usually labeled. Removing these items is part of clearing and grubbing.

The wooded and open (non-wooded) areas look something like this:

Plan and profile sheets show existing topography in relation to the R/W. The sheets show buildings according to their size and shape, and most buildings are labeled as to their materials, their height or their functions. For example:

Buildings are usually removed by others before construction begins, but the plans show their location at the time the plans were drawn up prior to letting the contract.

CLEARING AND GRUBBING SHEETS

Some contract plans contain clearing and grubbing sheets, mainly on rural projects. They show more detailed notes than plan and profile sheets concerning types and boundaries of areas to be cleared along the R/W. Usually, the first clearing and grubbing sheet contains notes about selective clearing and grubbing plan sheet - so you can see where the trees are and where the limits of clearing and grubbing are shown.

QUIZ

Which of the following may be considered part of clearing and grubbing?

- A. Relocating underground cables
- B. Removing an abandoned septic tank
- C. Removing building foundations
- D. Burning or otherwise disposing of debris found in the R/W.

What three plan sheet show clearing and grubbing information and also selective clearing and grubbing?

Refer to the next page to answer the questions below, regarding Financial Project ID 000000-00000

What types of vegetation can be cleared from between stations 120 + 00 and 125 + 00?

What must be done to the well between stations 101 + 00 and 102 + 00 in the west-bound lane?

Will the oak and pines to the right of station 115 + 00 be cleared? _____

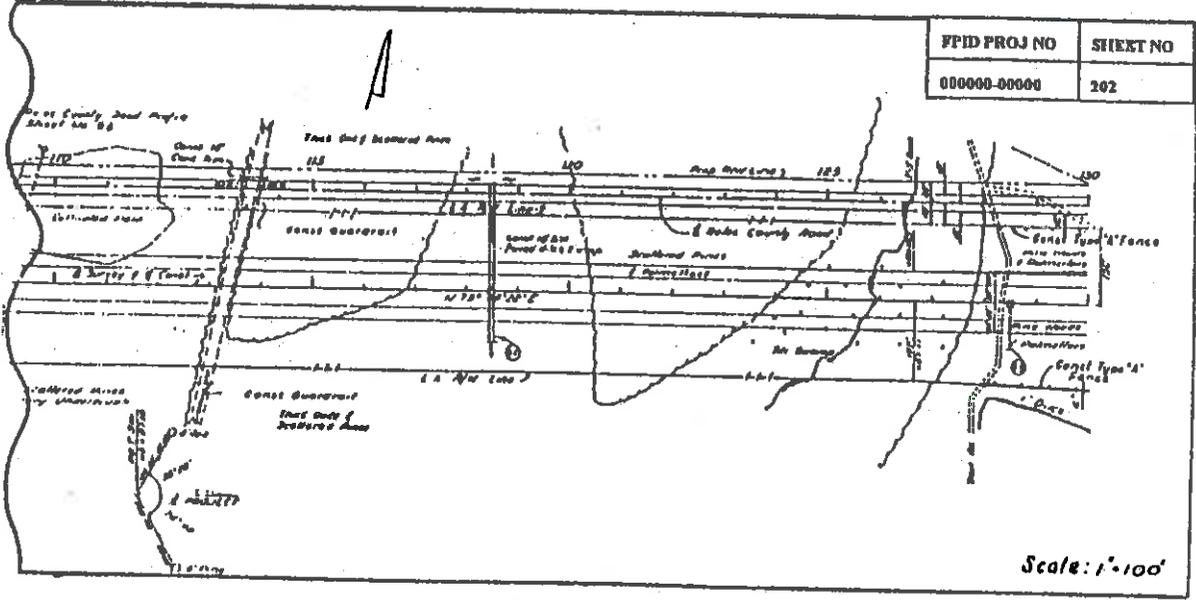
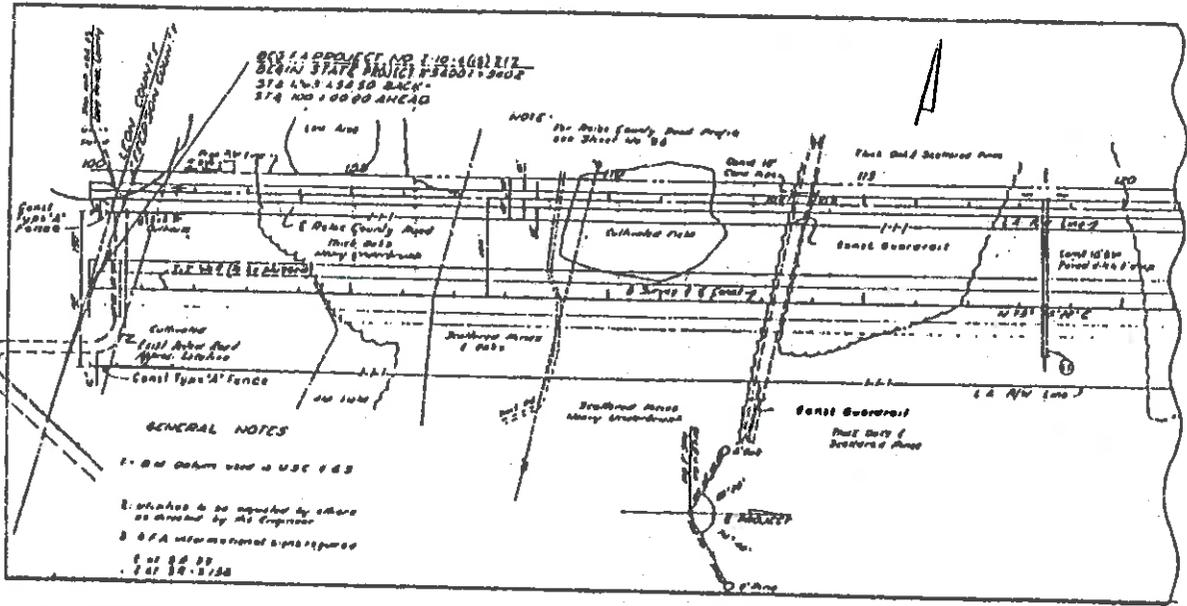

That's it for the first chapter. But before you go any further, there are a few things you should keep in mind to make the best of this course:

- ▶ Take time to study. Don't expect to learn well by just reading - you must study.

- ▶ Study is not the same as memorizing all the material. Don't try to memorize everything you read. Instead, study well enough to understand everything and remember the main points and the special terms.

- ▶ Be guided by how well you do on the quizzes in this text. If you cannot answer all the quiz questions easily, restudy the text until you can. If repeated study does not help, get help from your supervisor.

ANSWERS TO QUESTIONS

Page 1-7

- ▶ when they will not be damaged or disrupt construction
- ▶ first plan and profile sheet
- ▶ B
- ▶ remove overhead power cables and poles
- ▶ others as directed by engineer
- ▶ overhead facilities and poles right of 15 + 00 to sta. 16 + 50

Page 1-13

- ▶ B; C; D
- ▶ typical section; plan and profile; selective clearing and grubbing sheets
- ▶ scattered pines and palmettos
- ▶ no; outside R/W

CHAPTER TWO

Utility Relocation Inspection

CONTENTS

UTILITIES	2-3
Overhead Utilities	2-3
Underground Utilities	2-5
Railroads	2-6
PRECONSTRUCTION PREPARATIONS	2-8
Review of Utility Agreements and Plans	2-9
Preconstruction Conference	2-11
Field Inspections	2-12
NONREIMBURSABLE AND REIMBURSABLE UTILITY RELOCATION	2-13
FIELD LOCATION	2-15
Staking Utilities	2-16
Marking Utilities	2-18
TRAFFIC CONTROL AND SAFETY	2-21
General	2-21
Railroads	2-21
Fire Hydrants	2-22
Trench Safety	2-22
Contractor/Utility Cooperation	2-22

CONTENTS, continued

INSPECTION DUTIES	2-24
Removal of Existing Utilities	2-25
Installation of New Utilities	2-27
Backfilling and Compaction	2-31
Temporary Patches	2-32
Landscaping	2-32
Conflicts	2-33
Summary	2-36
DOCUMENTATION	2-38
Daily Report of Construction	2-38
Utility Diary - Daily Entry	2-41
Railroad Dairy - Daily Entry	2-42
Notice of Reimbursable Utility Construction Work	2-47
ANSWER TO QUESTIONS	2-50

UTILITY RELOCATION INSPECTION

UTILITIES

There are many types of utilities that must be particularly in urban areas. Before we discuss your inspection duties, we should mention briefly the main types of utilities you will encounter on the job. We can divide the types into three main groups: overhead utilities, underground utilities and railroads.

OVERHEAD UTILITIES

Generally, overhead utilities carry electrical currents. They may not all be direct power lines, but they all contain electrical charges. Some common types of overhead utilities are listed on the following page.

The listing below is by utility:

- ▶ **Power Companies**
 - distribution poles, conductors (lines) and transformers
 - transmission tower and conductors
 - transmission lines, distribution lines, service connections.

- ▶ **Telephone and Western Union**
 - telephone poles and lines
 - telegraph poles and lines.

- ▶ **State, County, Municipalities**
 - traffic signals
 - lighting systems.

- ▶ **Cable television.**

UNDERGROUND UTILITIES

Underground utilities include electrical conductors (power, telephone and telegraph lines) as well as many other types of utilities. Again, the listing below is by utility:

- ▶ **Power Companies**
 - transformers
 - television cables
 - distribution facilities
 - transmission facilities
 - vaults

- ▶ **Telephone, Western Union and Fiber Optic**
 - telephone cables
 - telephone lines
 - fiber optic cables
 - ducts
 - manholes

- ▶ **Water, Gas and Sewer**
 - mains
 - valves
 - service connections
 - manholes

You probably can easily spot overhead utilities - they are visible and you are familiar with them. But what about underground utilities? You don't see what is underground. Pipe ends are visible at certain places, but power and telephone cables are not. Also, television cables are located underground, as well as sanitary sewers, water mains and gas mains.

One thing you should know about these utilities is that many may appear similar. Most electrical conductors and telephone cables are carried in pipe - as are gas, water and sewer lines. Because of these similarities it is important that you be able to read your plans and know which utility is located where.

RAILROADS

The railroads have many different facilities that should be dealt with before highway construction. Railroad crossing and signals include the following items:

- ▶ railroad ties and rails,
- ▶ crossing slab,
- ▶ guard timbers,
- ▶ guard rails,
- ▶ rail joints,
- ▶ signal lamps and bells,
- ▶ signal masts and crossarms,
- ▶ relays
- ▶ battery boxes and signal cases,
- ▶ cantilevers,
- ▶ gate arms, and
- ▶ advance warning signals (circuitry).

These items are at ground level or above, and they can be located easily but be sure to also locate the power lines that run to the electrical power source.

QUIZ

Indicate which of the following utilities would be found underground and which overhead:

Conductors _____

Transformers _____

Telephone Lines _____

Telegraph Lines _____

Gas Mains _____

Water Valves _____

Beside underground and overhead, what is another important utility that you will encounter?

Does railroad utility relocation work include signals and light? _____

PRECONSTRUCTION PREPARATIONS

Before any utilities are located in the field, you, the Inspector, have a number of things to do. In this section, we will discuss the preparations that are made before field work begins. We will cover:

- ▶ the review of the Utility Agreement and the Utility Adjustments section of the plans.,
- ▶ the preconstruction conference, and
- ▶ on-site field inspections.

The responsibilities for these activities may vary from district to district, but each step must be taken. For the purpose of our discussion we will cover all of the steps as they relate to field Inspector - even though the staffing on any project may be different.

REVIEW OF UTILITY AGREEMENTS AND PLANS

The document that will initiate work is a Utility Agreement. In some cases you will not see this Agreement. At the very least, you should know that the Project Engineer has it. If you do see it, you are to study it, in detail:

- ▶ Be sure that utilities shown as removals or relocations on the plans are mentioned in the various Agreements. You will need to check the utility adjustment sheet for this.

- ▶ Be sure that drainage structures will not interfere. You will need to check the drainage sheets of the plans for this. Also check bridge footing and piling sections.

- ▶ Be sure that the utility relocations are realistic. A thorough examination of the agreements and plans may reveal a conflict between utilities and proposed road or bridge construction - or even other utilities work.

Any potential problems encountered during your review should be discussed with the Project Engineer. He can investigate the problems. Your job is to be familiar with the Agreement and any provisions, plans or other documents that will be used during the work.

QUIZ

In order to prepared for utility relocation, you should review _____ and _____,
know the subjects discussed at the _____, and take part in _____.

The Utility Agreement indicates that power lines must be relocated 15 feet (4.6m) from its original position.

Where do you look for verification in the contract documents? _____

If the relocation does not check out, what should you do? _____

For underground utility relocations, what other parts of the plans should you check for interference?

PRECONSTRUCTION CONFERENCE

A preconstruction conference is held prior to the beginning of road construction. This meeting is attended by representatives of the utility companies, the contractor, the FHWA, the Dot and other interested parties. At this meeting, schedules and completion dates are established, relocations are discussed and reviewed, and work sequences are coordinated so that utility and construction work do not interfere with each other.

In some instances, one or more utility relocations will be completed before the preconstruction conference. When this happens, it is important that the preconstruction conference the relocations be discussed in relation to their final locations, how they are marked in the field and any conflicts with construction that still exist.

FIELD INSPECTIONS

When practicable, you should make an on-site field inspection of the project with your Project Engineer and representatives of the Utilities. What should you look for? Well, a few things are just common sense:

- ▶ The project should be properly staked.
- ▶ The relocated utilities should not conflict with proposed highway construction.
- ▶ Access routes, traffic control and public safety should be discussed and reviewed in the field.

The importance of reading plans comes up again. All of the steps we have discussed are checks and re-checks of the plans, the field sites and the Utility Agreements.

Sometimes the plans do not show what is actually in the field due to an oversight. When this happens, a proper location for an installation may need to be found. During the field inspection is good time for the Project Engineer to recommend a new site. But keep in mind that the relocation should:

- ▶ be within the R/W ; and
- ▶ not interfere with construction or other utilities.

NONREIMBURSABLE AND REIMBURSABLE UTILITY RELOCATIONS

Before we go any further, we should mention something about the two types of utility relocations - nonreimbursable and reimbursable. Their characteristics are outlined below:

In Nonreimbursable Work:

- ▶ the Department does not share in the expense of relocation with the Utility,
- ▶ the Utility occupies Department R/W under a permit,
- ▶ the utilities must be adjusted to resolve conflicts and speed construction, and
- ▶ the work is documented on the Daily Report of Construction.

In Reimbursable Work:

- ▶ the Department pays for the relocation of the utility,
- ▶ the Utility occupies Department R/W under a permit OR the Department occupies Railroad R/W,
- ▶ the utilities will be relocated so that obstruction to construction are removed, and
- ▶ the work is noted on the Daily Report of Construction and documented in detail on the Railroad and Utility Diary - Daily Entry.

In both types of work:

- ▶ the Utility owns the facilities,
- ▶ the Utility is responsible for actually relocating their facilities,
- ▶ the Utility supplies all materials and manpower for installations, including their own inspectors, and
- ▶ the Department supplies an Inspector to check backfilling operations.

QUIZ

If utility relocations are completed prior to the preconstruction conference, what must be discussed at the conference?

If a utility relocation must be decided in the field, which of the following guidelines should be considered?

- A. Interference with construction and other utilities
- B. Outside R/W
- C. Inside R/W

Place an "N" next to the characteristics of nonreimbursable work, an "R" next to the characteristics of reimbursable work, and "B" next to those that apply to both.

- 1. Utility pays for full expense of relocation.
- 2. Utility occupies Department R/W.
- 3. Department occupies Railroad R/W.
- 4. Utility is adjusted to resolve conflicts with construction.
- 5. Department pays part of relocation cost.
- 6. Work is documented in detail on the Railroad and Utility Diary - Daily Entry.
- 7. Utility is responsible for relocating the utilities.

Do you understand the difference between reimbursable and nonreimbursable work? For you, the most important difference between them is the amount of documentation needed. But you will have similar important inspection duties in both. Let's take a look at your job when begins in the field.

FIELD LOCATION

In order to check the field site with the plans, you must be able to read the stake that the Utilities use to mark the locations of underground lines and above ground facilities. The stakes are set from lines and grades established by the Department or the Contractor. The Department will establish control points. The utility companies obtain information they need from these stakes or other Department documents, and set the stakes needed to adjust their facilities.

The stake at right is typical. It marks the centerline of the conduit, is driven to grade and is color coded for easy identification, your job will be to check with the Utilities to be sure you know what their stakes indicates and how you can use them.

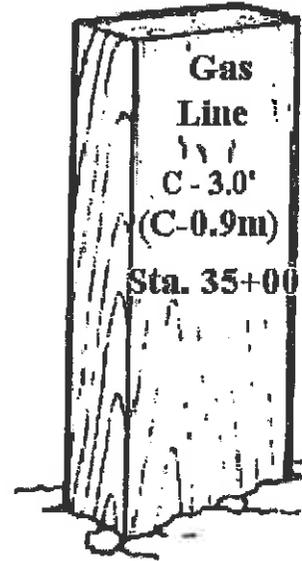

In some cases, stakes may not be used because the utility is directly under an existing pavement. Here, a tack and a can of spray paint will be all that is needed to mark and identify a point on the pavement.

STAKING UTILITIES

Sewer, water, gas and other underground utilities may be identified by stakes. These stakes will indicate the depth at which the lines are buried. They also identify the station number.

Typical water and sewer lines stakes are shown below:

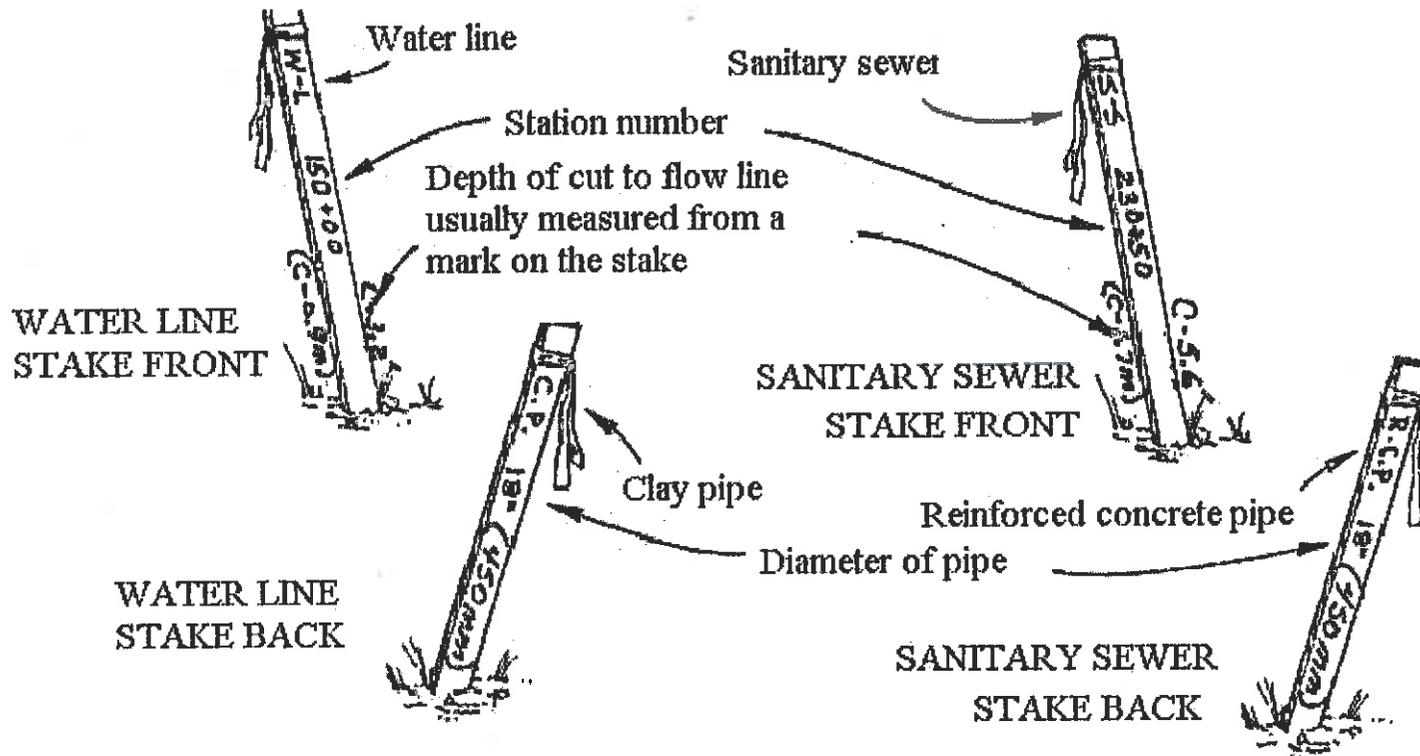

Ribbons or flags are tied to the utility stakes to make them more visible.

Existing underground facilities to remain in the R/W will be indicated on the plans. They must be protected from accidental damage during roadway construction operations. This can be done by clearly marking the location of the underground utility lines. This is the responsibility of the owner of the facility.

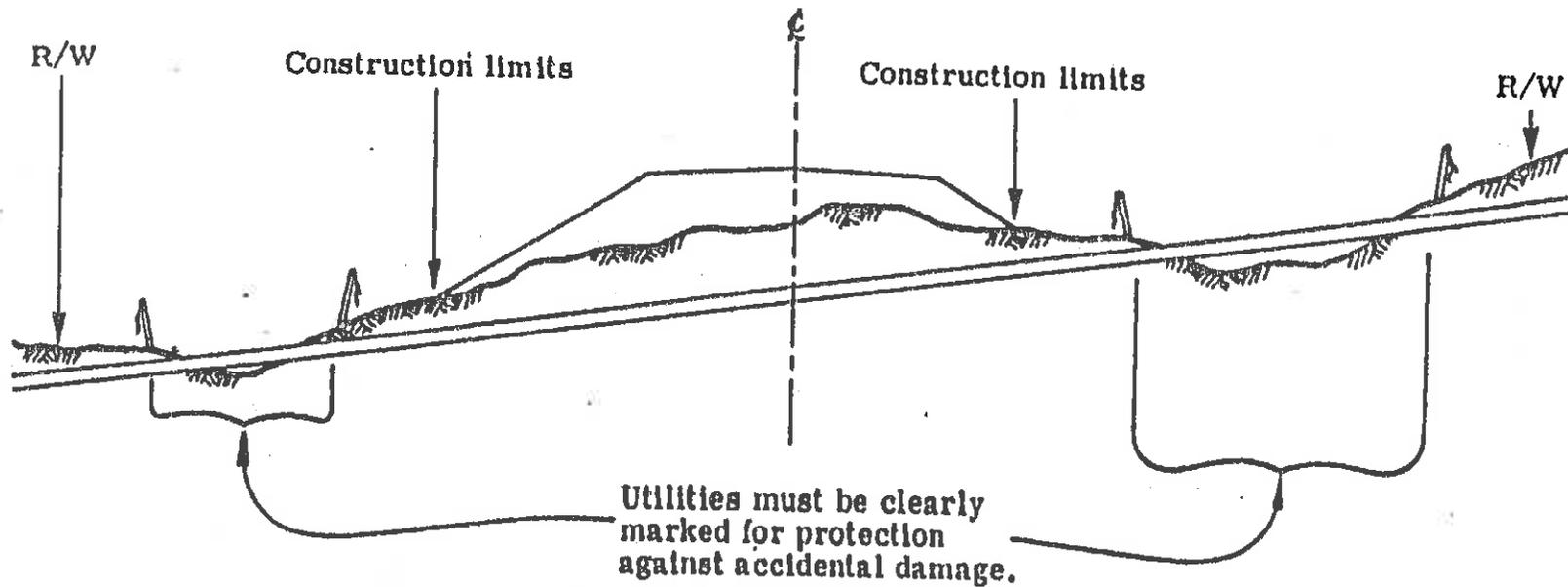

MARKING UTILITIES

Utility structures such as sewer manholes near the construction limits should be protected by barricades. If they are in the traveled roadway, they must meet the minimum standards as shown in the Manual on Uniform Traffic Control Devices. Two types are shown here. The crossbars are orange and white.

All underground utility lines must be clearly marked and protected from drainage. If damage occurs during construction, the Contractor must make repair arrangements with the owners of the utilities and restore the interrupted services. We will discuss this in detail later in this chapter.

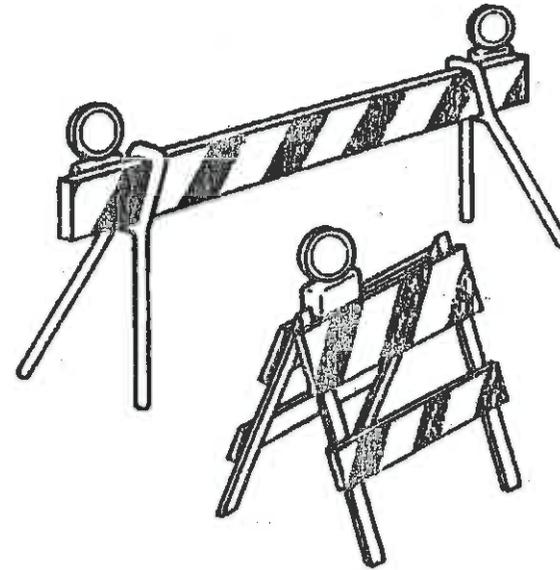

QUIZ

The questions below refer to the stake on the right.

What does this stake mark?

The utility is _____ feet (meters) below the

Where is the utility located?

If the utility passes under a paved driveway at Sta. 295 + 00, how would its location be marked?

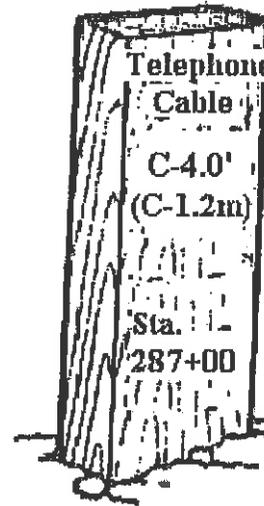

QUIZ, continued

What do the two sides of the stake shown tell you?

Who is responsible for locating and staking utility lines that are to remain in place? _____

Who is responsible for making the necessary arrangements for repair of utilities damaged during construction?

How should sewer manhole be protected from traffic? _____

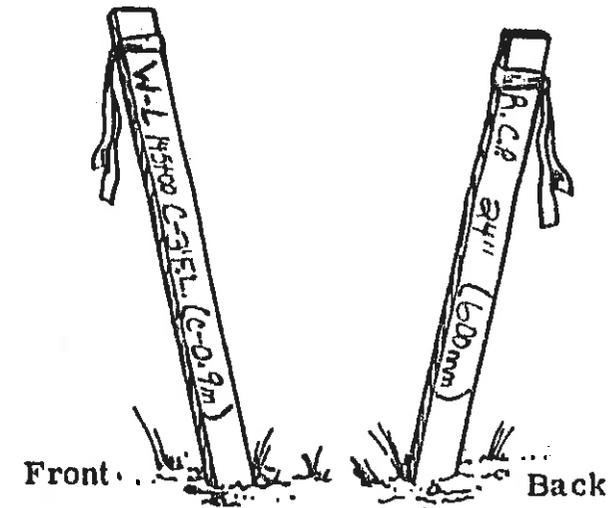

TRAFFIC CONTROL AND SAFELY

GENERAL

Utility relocations many times require access to existing roadway. In order to keep the traffic controlled and safe, the Utilities must use and maintain the proper traffic control devices. As an Inspector, you should check the traffic control procedures used, to be sure that the Utilities comply with the standards in the Manual on Uniform Traffic Control Devices. There is one important point that you must remember: the Manual presents the MINIMUM requirements for normal conditions - where complex or hazardous conditions exist, additional warning and safety devices will be needed.

Traffic must be maintained during any open trenching. During daylight, only-one way traffic may be possible, but at night, two-way traffic must be maintained. If a detour is needed, be sure that it has been approved by the Project Engineer.

RAILROADS

The railroad shall be contracted prior to any work being done within the railroad right-of-way. During work on railroad crossings, you must be sure that the Contractor erects and maintains the proper advance warning signs.

FIRE HYDRANTS

Work around fire hydrants will disrupt fire protection services. The Contractor must not begin work near fire hydrants before the local fire authorities have made provisions for continued fire protection.

TRENCH SAFETY

Shoring and bracing in trenches is required where necessary to prevent the sides of the trench from caving in. Be sure to follow the standards in the OSHA manual and the minimum standards for barricades in the Manual on Uniform Traffic Control Devices.

CONTRACTOR/UTILITY COOPERATION

Not everything works as planned. When things go wrong, your first concern should be to restore a safe and normal situation. Many problems can be quickly solved - when the Contractor and Utility personnel cooperate. Many more problems can be avoided altogether by proper coordination of utility and construction work. Where do you fit in? As an Inspector, you should ensure that the Contractor and Utility understand what each is responsible for and when the work is to done. These problems should have been ironed out during the preconstruction conference, or shortly thereafter, but it probably will not hurt to check on each party's progress from time to time.

QUIZ

The Utility company has impeded the flow of traffic in order to relocate a telephone lines, and has set up signs, cones and flashing lights. How will you know if these devices are being used properly?

If the Utility has placed the number of signs required by the Manual, but you feel the situation is extremely hazardous, could the Utility be asked to place more signs? _____

An open trench is excavated for a television cable relocation. Which of the following are proper guidelines that you should ensure?

- A. One-way traffic in daylight, two-way at night
- B. One-way traffic in daylight and at night
- C. Detour to maintain two-way two-way traffic at all times.

What must be done before work begins near fire hydrants? _____

INSPECTION DUTIES

As an Inspector, what do you actually inspect during the relocation of utility? Well, your inspection duties for utility work are not as many as for some other types of work, but they are just as important.

Keep the following in mind: If utilities are relocated in the wrong location, or if the work is not of proper quality, the errors will not appear, particularly underground, until roadway construction has begun or is completed. Then the repair work will be more dangerous, more difficult and more costly. So even though you have only a few inspection duties, be sure that you follow through on all of them.

This section covers your duties, including the inspection of:

- ▶ removal of existing utilities,
- ▶ installation of new utilities,
- ▶ backfilling and compaction,
- ▶ patches and landscaping,
- ▶ unforeseen problems.

So, what do you inspect?

REMOVAL OF EXISTING UTILITIES

Materials that are moved from the project under a reimbursable utility agreement should be stockpiled and checked by you and a Utility representative. The purpose of this inspection is to determine whether or not the material is reusable. Also, is it scrap with some monetary value or is it junk with no monetary value?

The actual removal of abandoned water and sewer lines is done mainly by the Contractor. Where pipe is to be salvaged or reused the removal is done by the utility using their own methods.

Another important purpose for inspecting removed materials is to determine the credit due the Department, for materials that are reusable and returned to storage for full credit. In order to keep track of what is done to all the materials, the Major Materials Report is completed. The Major Materials Report on the next page shows the items and how they were disposed.

STATE OF FLORIDA DEPARTMENT OF TRANSPORTATION
MAJOR MATERIALS REPORT
 Reimbursable Utility Project

FORM 710-010-03
 UTILITIES - 11/98
 Page 1 of 2

NAME OF AGENCY/UTILITY OWNER Florida Utility Co.
 FINANCIAL PROJECT ID 000000-00000
 FDOT PROJECT NUMBER 00000-0000
 FAP PROJECT NUMBER I-35-1 (377) 94
 UTILITY WORK ORDER NUMBER S10-7043-884
 REPORT NO. 1

(1) = (2) + (3) + (4)

EXPLANATION

ITEM DESCRIPTION	Removed	Re-Used on Project	Scrapped or Junked	Salvaged	
Clamps, cond., Post insulator	2	0	2	0	Junk No monetary Value
Clamps, cond., insulator	1	0	1	0	Junk No monetary Value
Clamp, pipe	1	0	1	0	Scrap Value Only
Washer, Curved 4" sq.	1	0	1	0	Junk No monetary Value
Insulator, spool	2	0	2	0	Junk No monetary Value
Protector, guy	1	0	1	0	Junk No monetary Value
Conductor, 343 AGAR	1,755 LF	0	1,755 LF	0	Scrap Value Only
Neutral, wire	585 LF	0	585 LF	0	Scrap Value Only

Interim Report

Final Report

Date of Inspection Feb. 19 99
 (See Other Side for Instructions)

Quantities Certified Correct
 Scrap Materials inspected and of no significant value
 Field diary conforms with above information

Grey Jones EAS Level II
 State of Florida Department of Transportation Representative

John Green
 Utility Owner Representative

INSTALLATION OF NEW UTILITIES

Reimbursable materials that are being installed should also be checked by the Inspector. Your check will not be to ensure quality, but to note the quantities and the quantities and the locations of the installations. You are responsible for documenting these quantities in your Utility Diary B Daily Entry. We will cover these reports later.

Nonreimbursable materials that are being installed will also be checked by you. Here again you will not be checking quality but you will note locations of the installations. You will be responsible for noting the information in your Daily Report of Construction.

On both reimbursable and nonreimbursable, you will need a tape, perhaps a hand level and level rod, and the plans to check locations.

Start at the stakes that are referenced to fixed points. Measure across, measure down, shoot a line to grade - do whatever you need to check the locations. They should match the plans. If not, get in touch with the Utility's foreman and your Project Engineer. However, be sure to check the following basic data:

- ▶ the final elevation of the utilities,
- ▶ recheck the location and size of the utilities with in the R/W,
- ▶ the clearances between the utilities and other utilities, drainage structures or passing traffic, and
- ▶ make sure the installation complies with minimum required above ground over head vertical clearance and/or underground minimum cover depths (see the Utility Accommodation Guide).

The last two checks are important - particularly where overhead utilities must meet requirements of the Specifications and the plans.

QUIZ

Why must you inspect removed utility materials?

- A. To determine credit due Depart
- B. To determine reusability
- C. To gather data for documentation.

Why must you inspect utility installations?

- A. To ensure quality workmanship
- B. To note quantities and locations
- C. To ensure that specified sizes are used.

Specifically, list four things you must check and record during utility installations?

1. _____
2. _____
3. _____
4. _____

QUIZ, continued

Use the data below to complete the Report on page 2-29A. Concern yourself with the items only.

⇒ Junk value only:

- ▶ 2 masts
- ▶ 8 lamps
- ▶ 2 cross bucks
- ▶ 2 4-way X arms
- ▶ 2 brackets

⇒ Abandoned in place

- ▶ 7 Conductor
No. 9 - 50 ft.
- ▶ 5 Conductor
No. 9 - 100 ft.

Check your entries on the next page.

STATE OF FLORIDA DEPARTMENT OF TRANSPORTATION
MAJOR MATERIALS REPORT
Reimbursable Utility Project

FORM 210-G10-1
MAY 1954
Page 1 of 1

NAME OF AGENCY/UTILITY OWNER Toonerville R.R.
FINANCIAL PROJECT ID 000000-00000
FDOT PROJECT NUMBER 11111-1111
FAP PROJECT NUMBER None
UTILITY WORK ORDER NUMBER 709-0P4-701119
REPORT NO. 1 of 1

(1) = (2) + (3) + (4)

EXPLANATION

ITEM DESCRIPTION	Removed	Re-Used on Project	Scrapped or Junked	Salvaged	

Interim Report _____

Final Report ✓

Date of Inspection April 21, 1999
(See Other Side for Instructions)

Quantities Certified Correct
Scrap Materials inspected and of no significant value
Field diary conforms with above information
Util. Coord: A.M. Bentley
State of Florida Department of Transportation Representative
Signals Maint: James T. Brown
Utility Owner Representative

Inspected By: Bill Bird, EAS Level II

The key to good documentation is always the same — supply as much information as you possibly can. This information is project both now and later.

STATE OF FLORIDA DEPARTMENT OF TRANSPORTATION
MAJOR MATERIALS REPORT
 Reimbursable Utility Project

FORM 710-010-03
 UTILITIES - 11/98
 Page 1 of 2

NAME OF AGENCY/UTILITY OWNER Toonerville R.R.
 FINANCIAL PROJECT ID 000000-00000
 FDOT PROJECT NUMBER 111111-11111
 FAP PROJECT NUMBER None
 UTILITY WORK ORDER NUMBER 709-0P4-701119
 REPORT NO. 1 of 1

(1) = (2) + (3) + (4)

EXPLANATION

ITEM DESCRIPTION		Removed	Re-Used on Project	Scrapped or Junked	Salvaged	
Mast	EA	2	0	2	0	Junk Value Only
Lamps	EA	8	0	8	0	Junk Value Only
Cross Bucks	EA	2	0	2	0	Junk Value Only
4 way x Arms	EA	2	0	2	0	Junk Value Only
Brackets	EA	2	0	2	0	Junk Value Only
7 Conductors # 9	LF	50	0	50	0	Abandoned in place
5 Conductors # 5	LF	100	0	100	0	Abandoned in place

Quantities Certified Correct

Interim Report _____

Scrap Materials inspected and of no significant value
 Field diary conforms with above information

Final Report _____

Util. Coord: A.M. Bentley
 State of Florida Department of Transportation Representative

Date of Inspection Feb. 16, 1999
 (See Other Side for Instructions)

Signals Maint.: James T. Bowen
 Utility Owner Representative

Inspected By: Bill Bird, EAS -Level II

BACKFILLING AND COMPACTION

Probably your most important inspection duty is to ensure proper backfilling and compaction around and over relocation underground utilities. If this work is done improperly, the effects will show up later as a weak area where settlement will occur.

The basic requirements are:

- ▶ Embankment material normally must be placed in approximately 8-inch (200 mm) loose lifts compacted to 6-inch (150 mm) lifts. If the Contractor constructs a test section to demonstrate that compaction can be achieved, he may place material in loose lifts of 16-inches (400 mm) and compact them 12-inches (300 mm).
- ▶ Base material must be placed in lifts where the compacted base thickness will be greater than 6-inches (150 mm).
- ▶ Excavated material that is not used as backfill can be placed at least 300 feet (90 m) from the site. The Project Engineer will direct the operation, so check with him for particulars.

One point should be made about density tests. You must determine who is responsible for conducting the test. then, the results must be recorded on the proper forms. For more details about this work, review the Earthwork Inspection training course.

TEMPORARY PATCHES

Where utilities are relocated by making open cuts in existing roadway, the finished work must be backfilled and the roadway patched. Temporary patches must be maintained to provide a smooth all-weather surface at all times. Permanent replacement of the temporary patch must be made as soon as all other work on the installation is completed. The only exception is when the roadway area will be reconstructed or paved in the immediate future.

LANDSCAPING

During the relocation of utilities, you must not allow the indiscriminate cutting of trees or disfiguring of any feature of scenic value. You should know, however, that some trimming is, at times, necessary and desirable. Any necessary trimming or cutting of trees by utility companies in the interest of public safety or continuity of utility service should not be considered indiscriminate. For example, where utilities cannot bypass the obstruction without keeping a clear roadside, then trimming and cutting may be needed.

CONFLICTS

If a conflict occurs, your major responsibility is to document it in detail and work towards a quick solution. Let's take an example B the most common problem : the Contractor is excavating for a drainage pipe and suddenly begins pulling up a telephone conduit or water line that is not shown in the plans. What should you do?

1. Notify the right people immediately and record the time of notification. You contact your Project Engineer and / or the Utility.
2. Find a reference stake and take an elevation at the damaged point. You can use a hand level and level rod B or you can contact the Project Engineer to arrange for survey work. Be sure to put your data in a field book or on a Report.
3. Make a sketch of the area if necessary. Show the proposed pipe, any other utilities, the roadway and, of course, the problem line. But, be sure to enter comments in detail.

Documenting the problem is important to resolve conflict and avoid future litigation. The field book below shows the things that you should note:

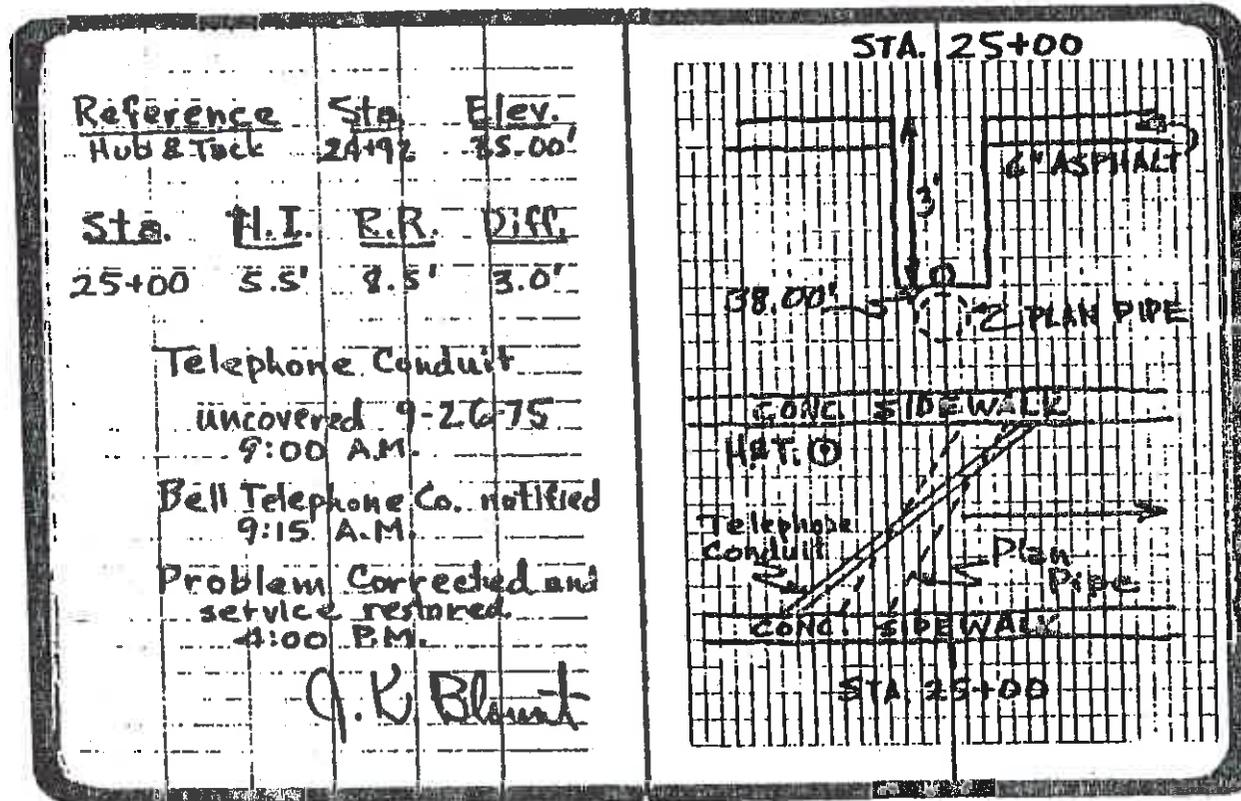

The solutions to conflicts should be coordinated between the Department, The Contractor and the Utility. You can help best by keeping detailed records and contacting your Project Engineer as soon as possible.

An optional damage report will be discussed at the end of this chapter.

QUIZ

Utility backfill materials must be placed in:

- A. 6-inch (150 mm) or 12-inch (300 mm) loose lifts.
- B. 6-inch (150 mm) or 12-inch (300 mm) compacted lifts.
- C. More than 2 lifts.

Base material must be backfilled around a utility. If the base thickness is 8 inches (200 mm), what is the minimum number of lifts that must be placed? _____

In the example above, how many moisture-density tests must be performed? _____

When is tree trimming considered necessary and desirable? _____

SUMMARY

Let's review quickly your important inspection duties. As an Inspector, you must:

- ▶ inspection utility installation and removal and complete the Major Materials Report, if performed under reimbursable agreement.
- ▶ inspect utility installations for:
 - elevations,
 - alignments,
 - dimensions, and
 - clearances which are stipulated in the Utility Accommodation Guide.
- ▶ inspect backfilling and compaction operations.
- ▶ ensure proper stockpiling of unused material.
- ▶ inspect temporary patching.
- ▶ bring conflicts to the attention of the Project Engineer.
- ▶ document all the work accomplished on the project.

We have not yet fully covered the last duty - documentation. Finish the quiz on the quiz on the next page, then start DOCUMENTATION:

QUIZ

The Contractor is excavating for a pipe line, but digs up an unknown water line. What is the first thing you should do?

The excavated material for a telephone line relocation is not needed as backfill. What can Contractor do with the excess material?

- A. Stockpile the material within sight of the construction area for later use.
- B. Stockpile the material at a site approved by the Project Engineer.
- C. Spread the material uniformly over the nearest slope.

DOCUMENTATION

One of the most critical aspects of utility relocation is documentation. Well maintained records ensure that the Department will pay correctly on reimbursable contracts, and the records indicate that the work is completed on nonreimbursable contracts. For you, the Inspector, accurate, up-to-date records eliminate embarrassments and guesswork when questions are asked and when final invoices are submitted to the Project Engineer for approval.

The basic document is the standard DAILY REPORT OF CONSTRUCTION. But reimbursable utilities work requires a few others - the UTILITY DIARYB DAILY ENTRY, and the MAJOR MATERIALS REPORT, which we have already discussed. All of these documents are printed by the Department and will be discussed in this section. We also will take a look at a worksheet which is not standard statewide, but which may be useful to you, as an Inspector.

DAILY REPORT OF CONSTRUCTION

The Daily Report of Construction is a two-page report of the work that you inspect during each day. Each day's report is not limited to two pages, however. You can use as many pages as are necessary to organize your records and describe the work underway.

On the next two pages are examples of Daily Report of Construction prepared for nonreimbursable utilities work. As you look them over, note the following:

- ▶ the number and classification of all personnel,
- ▶ the equipment used,
- ▶ the number of hours for labor and equipment, and
- ▶ the work described in detail.

This Daily Report records a utility relocation under a nonreimbursable agreement. Study the main points. Then look at the Daily Report on the next page.

STATE OF FLORIDA DEPARTMENT OF TRANSPORTATION
DAILY REPORT OF CONSTRUCTION

FORM 700-010-13
 CONSTRUCTION - 05/99
 Page 1 of 2

Select One:
 Subcontractor
 Contractor

DESCRIPTION OF WORK		
CONTRACTOR: Alexander Telephone, Co.		
OPERATION and LOCATION		TIME (AM/PM?)
Relocating telephone cables at poles at base Sta. 501 + 00.11 and Sta 503 + 00.11		BEGINNING: 7:30am ENDING: 4:00pm

PERSONNEL	NO.	HOURS WORKED
SUPT.	1	8
FOREMAN	1	8
SKILLED	2	8
SEMI SKILLED	3	8
COMMON	1	8
TRAINEE		

MATERIALS RECEIVED			

EQUIPMENT (ACTIVE/IDLE)											
A	I	A	I	A	I	A	I	A	I	A	I
1											
	AIR COMPRESSOR		CULTIVATOR		POWER BROOM		TRUCK TRAMP				
	AIR HAMMER		DRAGLINE		PUMP		TRACK FLATBED				
	ASPHALT PAVER		EARTH MOVER		ROLLER, STEEL WHEEL		TRUCK GREASE				
	ASPHALT DISTRIBUTOR		FRONT END LOADER		ROLLER, TRAFFIC		TRUCK LANE STRIPING				
	BACKHOE		HAND LINE-R		ROLLER, VIBRATORY	4	TRUCK, PICKUP				
	BULLDOZER		HANSHOW		ROTARY TILLER/MIXER		TRUCK WATER				
	CONCRETE BUCKET		GENERATOR		SPREADER, BOX		WELLPOINT SYSTEM				
	CONCRETE SAW	1	MECHANICAL TAMP		SPREADER, SEED						
	CONCRETE SCREED		WELDING MACHINE		SPREADER, FERTILIZER	2	utility truck				
	CONCRETE VIBRATOR		MOTOR GRADER		TRACTOR, FARM						
	CRANE, CRAWLER		MULCHER		TRANSPORT	1	auto motor				
	CRANE TRUCK		PILE DRIVER & HAMMER		TRUCK, BUCKET						

ESTIMATED CONTRACT QUANTITY INCREASES TODAY			
ITEM NO.	ITEM	QUANTITY	REMARKS AND CALCULATIONS

FIN PROJECT NO.: 200011-1501	F.A. PROJECT NO.: N/A	CONTRACT NO.: 16235	DATE: 4/7/1999	DAY OF WEEK: MONDAY	CONTRACT DAY: 2
---------------------------------	--------------------------	------------------------	-------------------	------------------------	--------------------

2-39A

FIN PROJECT NO.: 200011-1501	F.A. PROJECT NO.: N/A	CONTRACT NO.: 16235	DATE: 4/21/1999	DAY OF WEEK: MONDAY	CONTRACT DAY: 2
---------------------------------	--------------------------	------------------------	--------------------	------------------------	--------------------

WEATHER CONDITIONS: Clear Partly Cloudy Heavy Clouds Fog

TEMPERATURE: 78 High 65 Low Temperature Restriction Specification No. _____

WIND: None Slight Strong

RAIN: None Light Heavy Showers

RAIN DURATION: 0-2 Hrs. 2-4 Hrs. 4-6 Hrs. All Day

WORKING CONDITIONS: Excellent Good Fair Poor Bad

DURATION OF ACCEPTABLE CONDITIONS: Acceptable All Day More Than 50% of Work Day Less than 50% of Work Day Unacceptable All Day

SOIL CONDITION: Dry Wet Extremely Wet

EFFECTS OF WEATHER ON MAJOR WORK ITEMS (CHECK CONTROLLING ITEMS):

Major and/or Controlling Work Items	No Effect All Day	Effected Less Than 50% of Work Day	Effected More Than 50% of Work Day	No Work All Day
	<input type="radio"/>	<input type="radio"/>	<input type="radio"/>	<input type="radio"/>
	<input type="radio"/>	<input type="radio"/>	<input type="radio"/>	<input type="radio"/>
	<input type="radio"/>	<input type="radio"/>	<input type="radio"/>	<input type="radio"/>
	<input type="radio"/>	<input type="radio"/>	<input type="radio"/>	<input type="radio"/>
	<input type="radio"/>	<input type="radio"/>	<input type="radio"/>	<input type="radio"/>
	<input type="radio"/>	<input type="radio"/>	<input type="radio"/>	<input type="radio"/>

GENERAL COMMENTS:

VISITORS:

TECHNICIAN'S SIGNATURE AND RATING: <i>Gregory J. Fackel</i>	HOURS AT JOB SITE:	TOTAL HOURS:
	FROM 7:30 TO 4:30	8

ENGINEER IN CHARGE (NAME, RANK AND INITIALS):

G.O. Smith, EAS Level III

2-39B

This Daily Report documents an "unforeseen conflict". Note that the Inspector has been quite specific about what happened and where.

STATE OF FLORIDA DEPARTMENT OF TRANSPORTATION
DAILY REPORT OF CONSTRUCTION

FORM 700-010-13
 CONSTRUCTION - 05/99
 Page 1 of 2

Select One:
 Subcontractor
 Contractor

DESCRIPTION OF WORK		
CONTRACTOR: Golden Star, Inc.		
OPERATION and LOCATION	TIME (AM/PM?)	
	BEGINNING	ENDING
1) Setting forms from curb and gutting Sta. 55 + 60 I.I. Roadway	7:30am	4:30pm
2) Grading for sidewalk between Sta. 25 + 50 to 27 + 50 I.I. Roadway		
3) Setting sidewalk forms between Sta. 20 + 00 to 21 + 50 I.I. Roadway		
4) Tamping sidewalk materials for concrete placement between Sta. 20 + 00 to Sta. 21 + 50 I.I. Roadway		

PERSONNEL	NO.	HOURS WORKED	MATERIALS RECEIVED
SUPT.	1	8	
FOREMAN	1	8	
SKILLED	9	8	
SEMI SKILLED	3	8	
COMMON	3	8	
TRAINEE			

EQUIPMENT (ACTIVE/IDLE)											
A		I		A		I		A		I	
1								2			
								1			
						1					
		1									
2								3			
2								1			
		3									
		1									

ESTIMATED CONTRACT QUANTITY INCREASES TODAY			
ITEM NO.	ITEM	QUANTITY	REMARKS AND CALCULATIONS

FIN PROJECT NO.: 100011-15201	F.A. PROJECT NO.: N/A	CONTRACT NO.: 15839	DATE: 4/21/1999	DAY OF WEEK: MONDAY	CONTRACT DAY: 51
----------------------------------	--------------------------	------------------------	--------------------	------------------------	---------------------

2-40A

FIN PROJECT NO.: 100011-15201	F.A. PROJECT NO.: N/A	CONTRACT NO.: 16839	DATE: 4/21/1999	DAY OF WEEK: MONDAY	CONTRACT DAY: 51
----------------------------------	--------------------------	------------------------	--------------------	------------------------	---------------------

WEATHER CONDITIONS:

TEMPERATURE: Clear Partly Cloudy Heavy Clouds Fog
 82 High 69 Low Temperature Restriction Specification No. _____

WIND: None Slight Strong

RAIN: None Light Heavy Showers

RAIN DURATION: 0-2 Hrs. 2-4 Hrs. 4-6 Hrs. All Day

WORKING CONDITIONS: Excellent Good Fair Poor Bad

DURATION OF ACCEPTABLE CONDITIONS: Acceptable All Day More Than 50% of Work Day Less than 50% of Work Day Unacceptable All Day

SOIL CONDITION: Dry Wet Extremely Wet

EFFECTS OF WEATHER ON MAJOR WORK ITEMS (CHECK CONTROLLING ITEMS):

Major and/or Controlling Work Items	No Effect All Day	Effect Less Than 50% of Work Day	Effect More Than 50% of Work Day	No Work All Day
_____	<input type="radio"/>	<input type="radio"/>	<input type="radio"/>	<input type="radio"/>
_____	<input type="radio"/>	<input type="radio"/>	<input type="radio"/>	<input type="radio"/>
_____	<input type="radio"/>	<input type="radio"/>	<input type="radio"/>	<input type="radio"/>
_____	<input type="radio"/>	<input type="radio"/>	<input type="radio"/>	<input type="radio"/>
_____	<input type="radio"/>	<input type="radio"/>	<input type="radio"/>	<input type="radio"/>
_____	<input type="radio"/>	<input type="radio"/>	<input type="radio"/>	<input type="radio"/>

GENERAL COMMENTS:
 12" water main blew out over the weekend washing out the asphalt base, curb and gutter and part of pavement at intersection of Franklin and Daniels Ave. City Water Dept. called to repair leak. Contractor backfilled hole.

VISITORS: _____

TECHNICIAN'S SIGNATURE AND RATING: <i>Tom T. Lucke EAS Level II</i>	HOURS AT JOB SITE:	TOTAL HOURS:
	FROM 7:30 TO 4:30	8

ENGINEER IN CHARGE (NAME, RANK AND INITIALS):
G. T. Jones EAS Level III *GT*

2-40B

UTILITY DIARY - DAILY ENTRY

This Utility Diary - Daily Entry is a good example for reimbursable utility work.

STATE OF FLORIDA DEPARTMENT OF TRANSPORTATION
 UTILITY DIARY - DAILY ENTRY
 (FORCE ACCOUNT WORK)

Form No. 710-010-02
 UTILITIES
 11/98
 Page 1 of 2

LOCATION AND DESCRIPTION OF WORK - Relocate 6" (150 mm) Stl. Gas Main for New Construction Cut and cap 6" (150 mm) Main, Retire 40 - 6" Stl. in the ground, - Open and Close 2 bell hole	
SPECIAL REMARKS FOR THIS DATE - New reloc. To be made at a later time	
MATERIALS USED	2 - 6" (150 mm) Stl. Dress 2 - 6" (150 mm) Stl. Caps 2 - 1½ (38mm) plugs
SALVAGED SCRAPPED	
LABOR - UTILITY FORCES (CLASS AND HOURS) - 1- Mechanic 8 hrs. 3- Apprentice Mechanics 8 hrs. (24 hrs.) 1- Master System Mechanics 3 hrs. 1- Systems Operator 3 hrs. 1- District Supervisor 3 hrs. 1- Master Mechanic (welder) 3hrs. <div style="text-align: right;">Total Man Hours 44</div>	
EQUIPMENT - UTILITY FORCES (DESCRIPTION AND HOURS) - 1- 2 ton truck 8 hrs. 2- ½ ton truck 3 hrs. (6 hrs.) 1- backhoe 8 hrs. 1- Compressor 8 hrs. 1- Mud - water pump 3 hrs. 1- 1½ ton truck 3 hrs.	
LABOR - CONTRACTOR FORCES (CLASS AND HOURS) -	
EQUIPMENT - CONTRACTOR FORCES (DESCRIPTION AND HOURS) -	

2-41A

STATE JOB NO.	FED. JOB NO.	UTILITY OWNER
100013-15305	EACI-95-1 (150) 5	Orange State Gas Company
DATE AND DAY OF WEEK	PREPARED BY	CONTRACTOR (IF NOT UTILITY FORCES)
20 Aug. 99 Tues	Jake Sprven	

DISTRIBUTION: ORIGINAL - UTILITY DIARY
 COPY 1 - DISTRICT FISCAL OFFICE WITH UTILITY INVOICE
 COPY 2 - UTILITY OWNER

UTILITY DIARY- DAILY ENTRY

The Utility Diary - Daily Entry is also a good example for reimbursable railroad crossing work.

Along with this Diary, the Major Materials Report on the next page was completed.

STATE OF FLORIDA DEPARTMENT OF TRANSPORTATION
 UTILITY DIARY - DAILY ENTRY
 (FORCE ACCOUNT WORK)

Form No. 710-010-02
 UTILITIES
 11/98
 Page 1 of 2

2-42A

LOCATION AND DESCRIPTION OF WORK - S.W. 72 SL (Sunset Drive) SPECIAL REMARKS FOR THIS DATE - OP-7090 P4- 701118 Note: Scrape materials inspected and released on job site	
MATERIALS USED 40 cross ties 178 tie plates 4 kegs track spikes 4 kegs done - head drive spikes 4004.00 BMF of Longitude timber 572.00 BMF of outside fluster block	Removed: 2- 187' (100 lb) rails 90 cross ties (scrapped) 120 L.F. timbers (scrapped) See note above, for scrape materials
LABOR - UTILITY FORCES (CLASS AND HOURS) - Section 8146 1- Foreman 4hrs. 2- Apprentice Foreman 4hrs. 4- Track man 4hrs.	
EQUIPMENT - UTILITY FORCES (DESCRIPTION AND HOURS) - 2 - 2 ton flat bed truck 4hrs. 1 - pick-up 4hrs. Misc. tool	
LABOR - CONTRACTOR FORCES (CLASS AND HOURS) - See Daily Report	
EQUIPMENT - CONTRACTOR FORCES (DESCRIPTION AND HOURS) - See Daily Report	

STATE JOB NO.	FED. JOB NO.	UTILITY OWNER
200017-15908	NONE	SLOW & LONG R.R.
DATE AND DAY OF WEEK	PREPARED BY	CONTRACTOR (IF NOT UTILITY FORCES)
Wed 4 21-99	James Brown	

CONTINUED ON ORIGINAL UTILITY DIARY
 COPY 1 - DISTRIBUTION DIVISION
 COPY 2 - UTILITY OWNER

STATE OF FLORIDA DEPARTMENT OF TRANSPORTATION
MAJOR MATERIALS REPORT
 Reimbursable Utility Project

FORM 710-010-01
 UTILITIES - 11-98
 Page 1 of 2

NAME OF AGENCY/UTILITY OWNER The Rite and Rong Railroad
 FINANCIAL PROJECT ID 111111-11111
 FDOT PROJECT NUMBER 11111-1111
 FAP PROJECT NUMBER None
 UTILITY WORK ORDER NUMBER OP-7090p4-701118
 REPORT NO. 1 of 1

(1) = (2) + (3) + (4)

EXPLANATION

ITEM DESCRIPTION	Removed	Re-Used on Project	Scrapped or Junked	Salvaged	EXPLANATION
Cross Ties (5" x 7")	90 EA		90 EA		No Monetary Value
Timbers (Flangway) (12"x7")	120 LF		120 LF		No Monetary Value
100 # rails (187 L.F. EA.)	2 EA			2EA	Remove and replaced at discretion of RR inspected released material on Job site.

Interim Report _____

Final Report _____

Date of Inspection April 21, 1999
 (See Other Side for Instructions)

Quantities Certified Correct
 Scrap Materials inspected and of no significant value
 Field diary conforms with above information

James Brown EAS Level II
 State of Florida Department of Transportation Representative
B.W. Jones
 Utility Owner Representative

QUIZ

Use the information below to complete the Daily Report of Construction on the Next page.

- ▶ The contract number is 16839. It is contract day 61.
- ▶ The Orange State Gas Company installed a 4" (100 mm) gas line on FIN. Project No. 200012-15201 on October 20, 1999, from station 345 + 25 Lt. to station 349 + 90 (360 + 50) Lt. The crew consisted of one foremen, 4 skilled men, 8 semi-skilled men and 8 common laborers.
- ▶ Their equipment included a Gradall, a front-end loader, a dump truck, 2 pick-ups, 2 tampers and one service truck,
- ▶ The weather was cloudy and mild, with a high 78EF (25EC) and a low of 68EF (20EC). The weather had no effects on the work.
- ▶ The work day was from 8:00 a.m. to 4:00 p.m., Tuesday, October 20, 1999.
- ▶ The company also repaired a broken 4" (100mm) gas line right of station 361 + 00 (397 + 00). Contractor cut the line accidentally while excavating for a cross-drain pipe.
- ▶ The Inspector's name is Bob Lakitas, EAS level II, and the engineer-in-charge is John Walker, EAS Level III

When you have completed this Report, Compare it with the one on the next page.

STATE OF FLORIDA DEPARTMENT OF TRANSPORTATION
DAILY REPORT OF CONSTRUCTION

FORM 700-010-13
 CONSTRUCTION - 05/99
 Page 1 of 2

Select One:
 Subcontractor
 Contractor

CONTRACTOR:			DESCRIPTION OF WORK	
OPERATION and LOCATION			TIME (AM/PM?)	
			BEGINNING	ENDING

PERSONNEL	NO.	HOURS WORKED	MATERIALS RECEIVED
SUPT.			
FOREMAN			
SKILLED			
SEMI SKILLED			
COMMON			
TRAINEE			

EQUIPMENT (ACTIVE/IDLE)							
A	I	A	I	A	I	A	I
		AIR COMPRESSOR		CULTIPACTOR		POWER BROOM	
		AIR HAMMER		DRAGLINE		PUMP	TRUCK, DUMP
		ASPHALT PAVER		EARTH MOVER		ROLLER, STEEL WHEEL	TRUCK, FLATBED
		ASPHALT DISTRIBUTOR		FRONTEND LOADER		ROLLER, TRAFFIC	TRUCK, GREASE
		BACKHOE		HAND LINER		ROLLER, VIBRATORY	TRUCK, LANE STRIPING
		BULLDOZER		NARROW		ROTARY TILLER/MIXER	TRUCK, PICKUP
		CONCRETE BUCKET		GENERATOR		SPREADER, BOX	TRUCK, WATER
		CONCRETE SAW		MECHANICAL TAMP		SPREADER, SEED	WELLPOINT SYSTEM
		CONCRETE SCREED		MILLING MACHINE		SPREADER, FERTILIZER	
		CONCRETE VIBRATOR		MOTOR GRADER		TRACTOR, FARM	
		CRANE, CRAWLER		MULCHER		TRANSPORT	
		CRANE, TRUCK		PILE DRIVER & HAMMER		TRUCK, BUCKET	

2-45A

ESTIMATED CONTRACT QUANTITY INCREASES TODAY			
ITEM NO.	ITEM	QUANTITY	REMARKS AND CALCULATIONS

FIN PROJECT NO.:	F. A. PROJECT NO.:	CONTRACT NO.:	DATE:	DAY OF WEEK:	CONTRACT DAY:
------------------	--------------------	---------------	-------	--------------	---------------

DISTRIBUTION: ORIGINAL - PROJECT FILE
 COPY - CONTRACTOR (AS REQUESTED)
 COPY - DISTRICT CONSTRUCTION ENGINEER

COPY - FHWA (F & OVERSIGHT)

FIN PROJECT NO.:	F.A. PROJECT NO.:	CONTRACT NO.:	DATE:	DAY OF WEEK:	CONTRACT DAY:
------------------	-------------------	---------------	-------	--------------	---------------

WEATHER CONDITIONS: Clear Partly Cloudy Heavy Clouds Fog

TEMPERATURE: _____ High _____ Low Temperature Restriction Specification No. _____

WIND: None Slight Strong

RAIN: None Light Heavy Showers

RAIN DURATION: 0-2 Hrs. 2-4 Hrs. 4-6 Hrs. All Day

WORKING CONDITIONS: Excellent Good Fair Poor Bad

DURATION OF ACCEPTABLE CONDITIONS: Acceptable All Day More Than 50% of Work Day Less than 50% of Work Day Unacceptable All Day

SOIL CONDITION: Dry Wet Extremely Wet

EFFECTS OF WEATHER ON MAJOR WORK ITEMS (CHECK CONTROLLING ITEMS):

Major and/or Controlling Work Items	No Effect All Day	Effected Less Than 50% of Work Day	Effected More Than 50% of Work Day	No Work All Day
_____	<input type="radio"/>	<input type="radio"/>	<input type="radio"/>	<input type="radio"/>
_____	<input type="radio"/>	<input type="radio"/>	<input type="radio"/>	<input type="radio"/>
_____	<input type="radio"/>	<input type="radio"/>	<input type="radio"/>	<input type="radio"/>
_____	<input type="radio"/>	<input type="radio"/>	<input type="radio"/>	<input type="radio"/>
_____	<input type="radio"/>	<input type="radio"/>	<input type="radio"/>	<input type="radio"/>
_____	<input type="radio"/>	<input type="radio"/>	<input type="radio"/>	<input type="radio"/>

GENERAL COMMENTS:

VISITORS: _____

TECHNICIAN'S SIGNATURE AND RATING:	HOURS AT JOB SITE:	TOTAL HOURS:
	FROM _____ TO _____	

ENGINEER IN CHARGE (NAME, RANK AND INITIALS):

2-45B

This Daily Report is properly completed. If your Report looks similar, go on to NOTICE OF REIMBURSABLE UTILITY CONSTRUCTION WORK. If your Report is missing information or improperly recorded, go back and study pages 2-38 through 2-40 first.

FIN PROJECT NO.: 200012-15201	F.A. PROJECT NO.: N/A	CONTRACT NO.: 16839	DATE: 10/20/1999	DAY OF WEEK: TUESDAY	CONTRACT DAY: 61
----------------------------------	--------------------------	------------------------	---------------------	-------------------------	---------------------

WEATHER CONDITIONS: Clear Partly Cloudy Heavy Clouds Fog

TEMPERATURE: 78 High 68 Low Temperature Restriction Specification No. _____

WIND: None Slight Strong

RAIN: None Light Heavy Showers

RAIN DURATION: 0-2 Hrs. 2-4 Hrs. 4-6 Hrs. All Day

WORKING CONDITIONS: Excellent Good Fair Poor Bad

DURATION OF ACCEPTABLE CONDITIONS: Acceptable All Day More Than 50% of Work Day Less Than 50% of Work Day Unacceptable All Day

SOIL CONDITION: Dry Wet Extremely Wet

EFFECTS OF WEATHER ON MAJOR WORK ITEMS (CHECK CONTROLLING ITEMS):

Major and/or Controlling Work Items	No Effect All Day	Effected Less Than 50% of Work Day	Effected More Than 50% of Work Day	No Work All Day
_____	<input type="radio"/>	<input type="radio"/>	<input type="radio"/>	<input type="radio"/>
_____	<input type="radio"/>	<input type="radio"/>	<input type="radio"/>	<input type="radio"/>
_____	<input type="radio"/>	<input type="radio"/>	<input type="radio"/>	<input type="radio"/>
_____	<input type="radio"/>	<input type="radio"/>	<input type="radio"/>	<input type="radio"/>
_____	<input type="radio"/>	<input type="radio"/>	<input type="radio"/>	<input type="radio"/>
_____	<input type="radio"/>	<input type="radio"/>	<input type="radio"/>	<input type="radio"/>

GENERAL COMMENTS:

Prime contractor accidentally cut 4" (100 mm) gas line at station 397 + 00 while excavating for a cross drain pipe. Contractor to pay for repair at own expense.

VISITORS: _____

TECHNICIAN'S SIGNATURE AND RATING: <i>Dot Sahital EAS Level II</i>	HOURS AT JOB SITE:	TOTAL HOURS:
	FROM <u>8:00</u> TO <u>4:00</u>	7 1/2

ENGINEER IN CHARGE (NAME, RANK AND INITIALS):

John Walker EAS Level III



2-468

NOTICE OF REIMBURSABLE UTILITY CONSTRUCTION WORK

For reimbursable utility work, a beginning and completion report must be prepared. This is the duty of the Project Engineer or a delegated person but the Project Engineer must still sign it. The Inspector should notify the Project Engineer of the beginning and completion of the work. The reports on this and the next page are for the relocation of railroad are for the relocation of railroad signals only.

STATE OF FLORIDA DEPARTMENT OF TRANSPORTATION
NOTICE OF REIMBURSABLE/NONREIMBURSABLE
UTILITY CONSTRUCTION WORK

FORM 700-016-01
CONSTRUCTION
8-000

BEGINNING COMPLETION

UTILITY CONSTRUCTION INCLUDES CONSTRUCTION OR RELOCATION WORK DONE BY UTILITIES OR RAILROADS UNDER A REIMBURSABLE/NONREIMBURSABLE AGREEMENT WITH THE DEPARTMENT.

FINANCIAL PROJECT NO. 100014-15201 F.A.P. NO. M-5410(1)

UTILITY JOB NO. 100014-15201 W.P.I. NO. 1(RW x SH)

STATE ROAD NO. 817 (N.W. 27th Ave.) COUNTY: DADE

DESCRIPTION (ACTUAL TYPE WORK & LOCATION): Modify existing protection devices with the addition of cantilevers 2,079 ft. southwest of R.R. M.P. 1029, DOT-STD Mile Post 0.121 (N.W. 27th Ave.) Proposed Signal to be Type IV.

UTILITY OWNER: Airline R.R. (SCL File 566638-E)

DATE OF AGREEMENT: 2/5/1999 Change Order 1# 4/25/99 (signal)

DATE WORK BEGAN: 6/9/1999 Change Order 2# 4/25/99 (crossing)

DATE WORK COMPLETED: 7/10/1999

REMARKS: This work consisted of installing 2 cantilevers 40' each with ten light each and gate assemblies with 40' and 44' gate arms respectively. An additional 10' of gate arm was installed temporarily on each gate arm to cover crossing until median area is constructed. An operation test was run by means of "shunting" the track two consecutive time and activated once by actual train operation. These tests were satisfactory. Those present for test were HAT Wilson, SCL R.R., Sig. Const. Supvr., Bill Case and J. Steller. Test were run 7/10/99

J. Pells

Utility Coordinator
RESIDENT/PROJECT ENGINEER

7/16/99
DATE

6501 N.W. 36th Street, Holckiss, Fla. 33166
ADDRESS

871-4481 Ext. 24
TELEPHONE NUMBER

DISTRIBUTION

COPY 1 - DISTRICT CONSTRUCTION ENGINEER
COPY 2 - RESIDENT/PROJECT ENGINEER (UTILITY FILE - SUBMIT WITH FINAL INVOICE)
COPY 3 - FEDERAL HIGHWAY ADMINISTRATION (F A PROJECTS ONLY)
COPY 4 - FEDERAL AID PROGRAMS MANAGER (F A PROJECTS ONLY)

RECEIVED WITH 

QUIZ

When is the Daily Report of Construction the only documentation for a utility relocation? _____

Reimbursable railroad crossing work requires documentation on _____ and noting on _____

For reimbursable utilities work, is the Notice of Reimbursable Utility Construction Work done at the beginning or completion of the work B or both? _____

ANSWERS TOP QUESTIONS

Page 2-7

- ▶ underground/overhead
- ▶ underground/overhead
- ▶ underground/overhead
- ▶ underground/overhead
- ▶ underground
- ▶ underground
- ▶ railroads
- ▶ yes

Page 2-10

- ▶ utility agreement; plans; preconstruction conference; on-site field inspections
- ▶ utility adjustment sheets in plans
- ▶ contact Project Engineer
- ▶ drainage sheets, bridge footing and the piling section in the bridge plan sheets

ANSWER TO QUESTION, continued

Page 2-14

- ▶ final locations;
how they are marked;
any conflicts.
- ▶ A; C
- ▶ 1. N
- ▶ 2. B
- ▶ 3. R
- ▶ 4. B
- ▶ 5. R
- ▶ 6. R
- ▶ 7. B

Page 2-19

- ▶ telephone cable
- ▶ 4.0' (1.2m); top of stake
- ▶ sta. 287 + 00
- ▶ tack in pavement and painted

Page 2-20

- ▶ waterline located at sta. 145 + 00
3 ft. (0.9m) below top stake to flowline;
reinforced concrete pipe, 24" (600mm)
diameter
- ▶ owner of utility
- ▶ contractor
- ▶ barricades

Page 2-23

- ▶ consult Manual on Uniform Traffic
Control Devices
- ▶ yes
- ▶ A or C
- ▶ contact local fire station or department

Page 2-28

- ▶ A; B; and C
- ▶ B; C
- ▶ 1. Elevations
- ▶ 2. Station numbers
- ▶ 3. Lengths
- ▶ 4. Clearances

ANSWERS TO QUESTION, continued

Page 2-35

- ▶ B
- ▶ two
- ▶ two
- ▶ public safety or continuity of service

Page 2-37

- ▶ contact your Project Engineer
- ▶ B

Page 2-49

- ▶ when it is non-reimbursable
- ▶ Utility Diary - Daily Entry; Daily Report of Construction
- ▶ both

CHAPTER THREE

Clearing and Grubbing Inspection

CONTENTS

INTRODUCTION	3-3
STANDARD CLEARING AND GRUBBING	3-4
General Requirements	3-4
Excavation and Embankment Areas	3-5
Structure Areas	3-6
Borrow Pit, Material Pit and Lateral Ditch Areas	3-7
Other Areas	3-7
Trees	3-10
Boulders	3-11
Limits of Clearing and Grubbing	3-11
SELECTIVE CLEARING AND GRUBBING	3-13
LEVELING TERRAIN	3-14
DISPOSAL OF MATERIALS	3-15
General Disposal	3-15
Burning	3-16
Timber and Crops	3-16

CONTENTS, continued

REMOVAL OF BUILDINGS, STRUCTURES AND PAVEMENTS	3-19
Removal of Buildings	3-19
Removal of Existing Structures and Existing Pavement	3-21
MISCELLANEOUS OPERATIONS	3-24
Plugging Water Wells	3-24
Removing Abandoned Gasoline Tanks	3-25
MEASURING AND PAYMENT	3-27
Clearing and Grubbing	3-27
Removal of Existing Structures	3-28
Removal of Existing Pavement	3-29
Plugging Water Wells	3-29
DOCUMENTATION	3-31
ANSWERS TO QUESTIONS	3-37

3

CLEARING AND GRUBBING INSPECTION

INTRODUCTION

The Standard Specifications include five main items in the Clearing and Grubbing Section:

- ▶ Standard Clearing and Grubbing;
- ▶ Selective Clearing and Grubbing;
- ▶ Removal of Building, Structures and Pavement;
- ▶ Disposal of Materials; and
- ▶ Plugging Water Wells.

In this chapter we will discuss each of these items - the requirements for the work and your inspection responsibilities. We will begin with STANDARD CLEARING AND GRUBBING.

STANDARD CLEARING AND GRUBBING

GENERAL REQUIREMENTS

Unless otherwise shown in the plans, standard clearing and grubbing is done in the following areas:

- ▶ excavation areas;
- ▶ roadway embankment areas;
- ▶ borrow pit, material pit and lateral ditch areas;
- ▶ structure areas, including pipe placement areas; and
- ▶ any other required areas shown on the plans.

In all of these areas standard clearing and grubbing will include the removal and disposal of all:

- ▶ timber and brush;
- ▶ stumps and roots;
- ▶ rubbish and debris; and
- ▶ building, structures and other obstructions.

Even though this list seems to cover everything, there are some specific requirements for how deep roots, stumps and other debris are to be removed below the ground surface. Let's look at each area and its requirements.

EXCAVATION AND EMBANKMENT AREAS

Standard clearing and grubbing for excavation and embankment areas is accomplished in three steps:

- ▶ First, all visible obstructions are removed to at least 1 foot (300mm) below the original ground.
- ▶ Next, the area is plowed to a depth of 6 inches (150 mm), to reveal any roots just below the original ground.
- ▶ Finally, these newly exposed ground obstruction are also removed to at least 1 foot (300mm) below the original ground line.

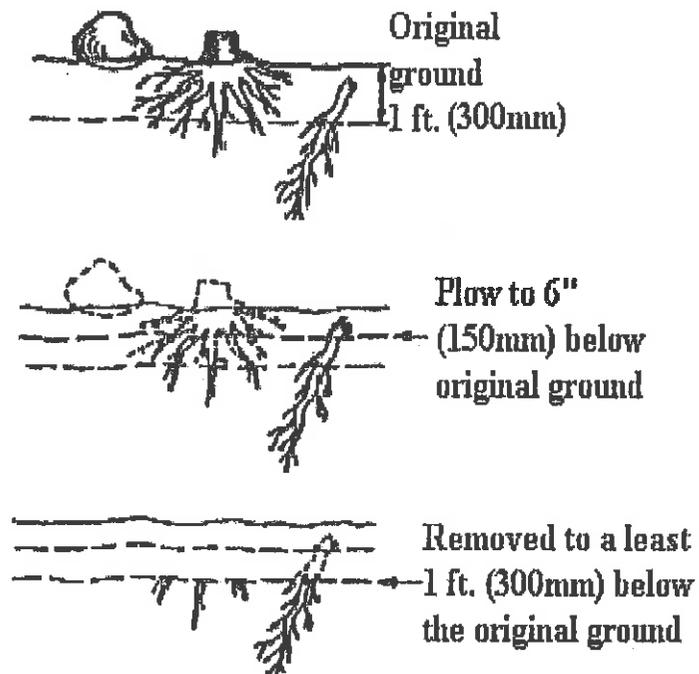

Keep in mind that this depth of 1 foot (300mm) is a minimum for roots and other debris. Tree stumps must be removed completely. Other large obstructions are generally removed completely when this is easier than cutting them off.

Clearing and grubbing in excavation areas doesn't end 1 foot (300mm) below the original ground. Any excavation within the roadway area must also be cleared and grubbing to within 1 foot (300mm) of the excavation surface. This area doesn't have to be plowed, but any visible obstructions or debris must be removed.

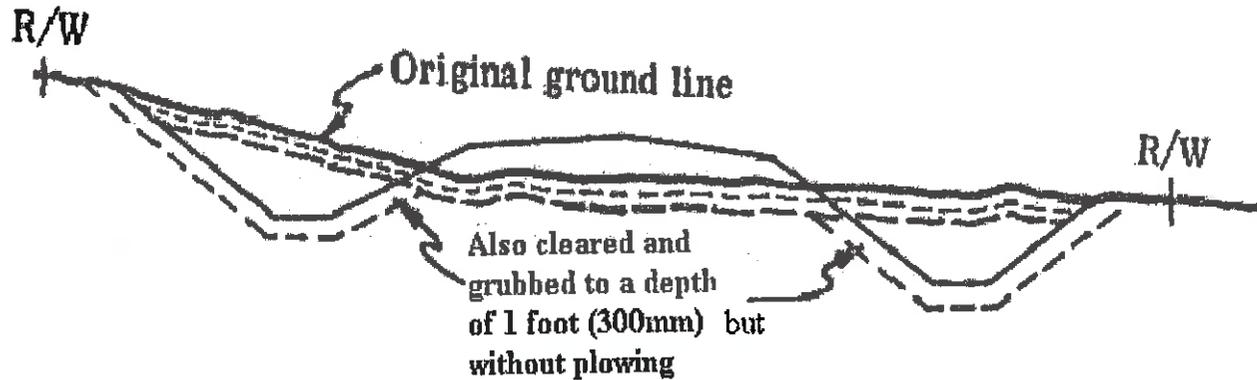

STRUCTURE AREAS

The same thing applies to excavation for structures. All roots and other debris that appear on or protrude through the surface the surface of the completed excavation must be removed to a depth of at least 1 foot (300mm) below the final excavation surface.

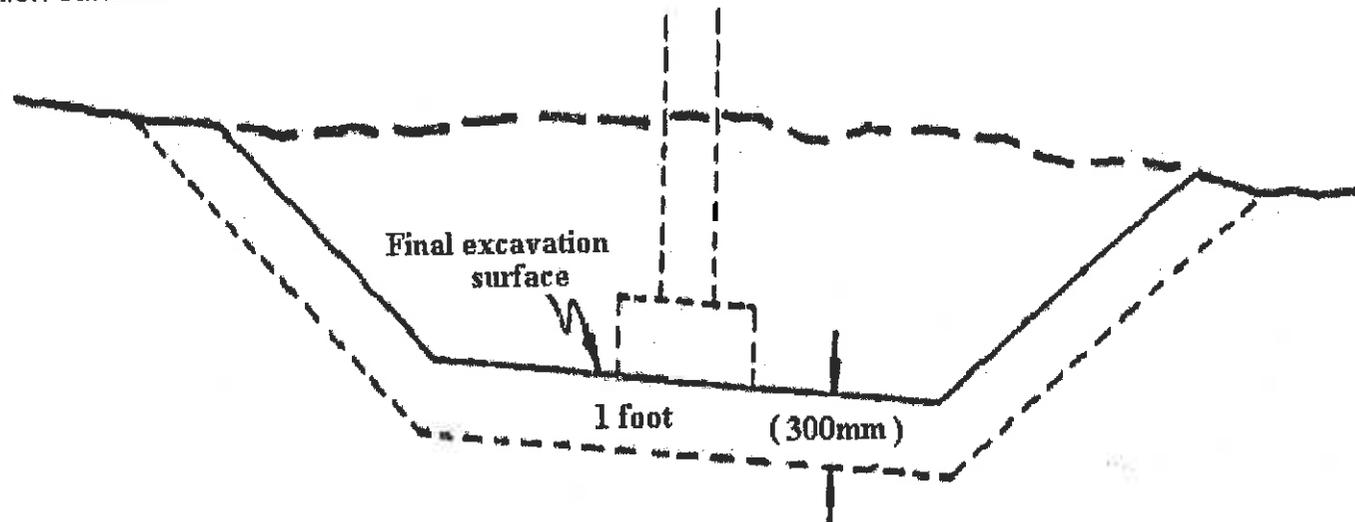

In the process of clearing and grubbing, frequent checks of all natural waterways and existing drainage ditches should be made to insure proper flow of water. Any blocked ditch or waterway should be called to the Contractor's attention and the situation corrected. Temporary pipes may be needed in some instances to provide drainage and to provide access to other parts of the project. These pipes should be of sufficient size and appropriate elevations to provide proper drainage.

BORROW PIT, MATERIAL PIT AND LATERAL DITCH AREAS

In borrow pits, material pits and lateral ditches, all stumps, roots and other debris that protrude through or appear on the surface of the completed excavation must be removed or cutoff below the final excavation surface.

In addition, clearing and grubbing in State-owned borrow pits, material pits and lateral ditches will extend to within 3 feet (900mm) of the R/W line. No clearing and grubbing is done within the 3 feet (900mm) inside the R/W line.

OTHER AREAS

Where standard clearing and grubbing is called for in other areas not covered in the above examples, all roots and other debris that appear on the original ground surface must be removed to a depth 1 foot (300mm) below the surface. However, no plowing is required in these areas.

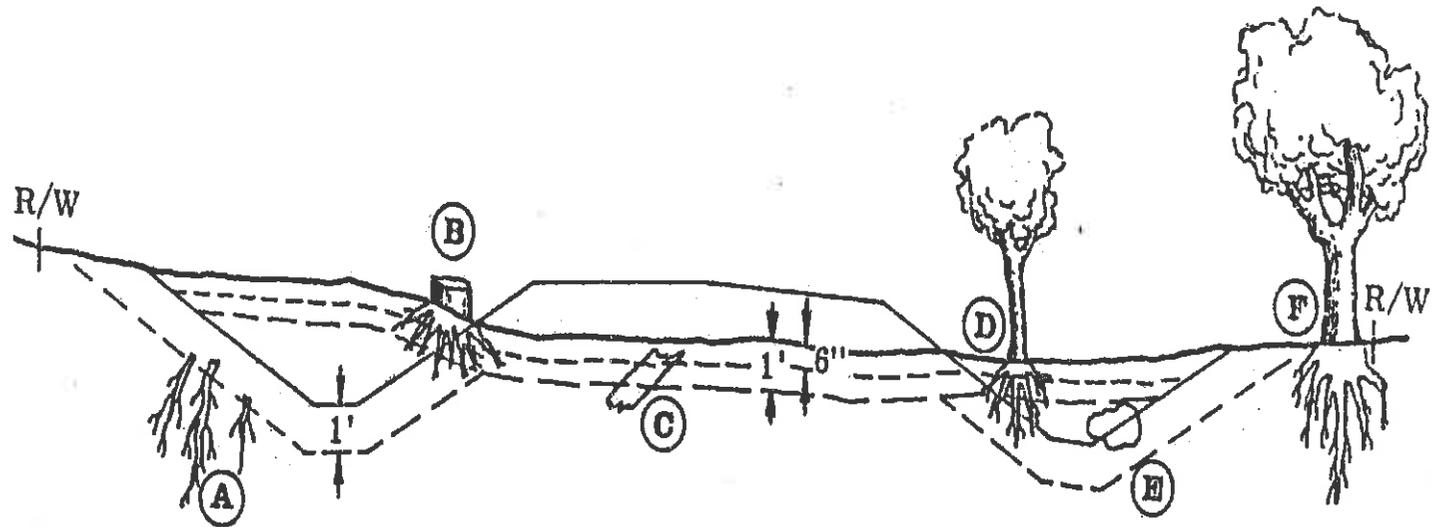

QUIZ

If standard clearing and grubbing is called for in the diagram in the diagram above -

Which item(s) will be removed before any plowing takes place? _____

Which item(s) will be removed after plowing? _____

Which item(s) will be removed as excavation is being finished? _____

Which item(s) will remain? _____

QUIZ, continued

In areas where embankment will be placed, how is clearing and grubbing done?

In the borrow pit in the diagram below, what should be done to the stump and roots shown?

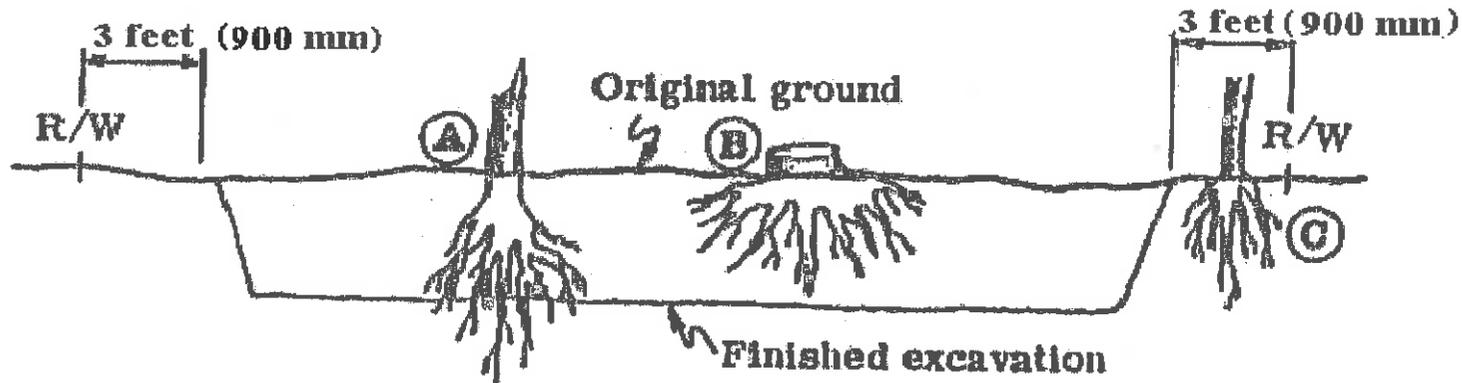

- A. _____
- B. _____
- C. _____

If you have any questions about this quiz, reread pages 3-3 through 3-7. Then go on to page 3-10.

TREES

In some cases, the Project Engineer may direct that certain trees not be removed, but left standing and protected. It may be required that low hanging and damaged limbs be removed from the trees that remain in place. This must be done in a manner that will not damage the remainder of the tree. One method is illustrated below.

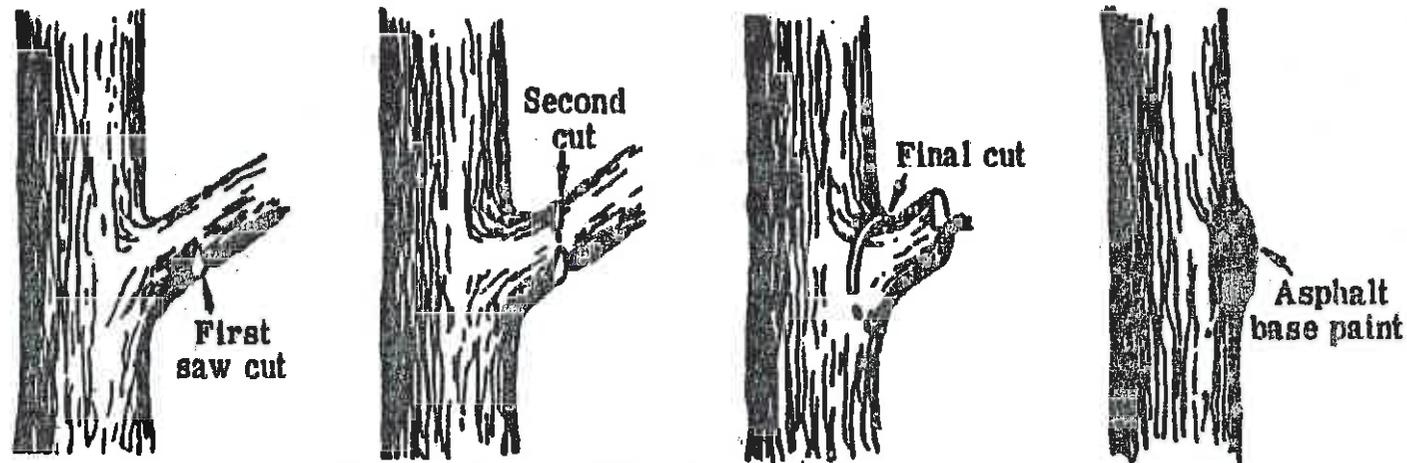

All trimming should be done by skilled workmen with good tree surgery practices.

Branches extending over the roadbed should be trimmed to give a clear height of 16 feet (5m) above the surface. Similarly, scarred areas of trees to be saved must be treated with an approved asphalt base paint.

On projects in National forest or parks, the special provisions will stipulate a date up to which forest authorities will be removing the marketable timber. This date must not be violated. In the event delay beyond such date is likely, clearance must be obtained from the District Office before permitting any cutting.

BOULDERS

Any boulders found on the surface of the ground within the construction area must be removed and placed in neat piles inside the R/W and adjacent to the R/W lines. These boulders must be piled, not placed to form a continuous wall. Be sure that the correct requirements are followed.

Boulders that are found in State-owned borrow areas may be used in the embankment if in compliance with the Standard Specifications.

LIMITS OF CLEARING AND GRUBBING

Before we leave standard clearing and grubbing, we should make one point about the amount of erodible earth that may be exposed. Under no circumstances must the surface areas of erodible earth exposed by clearing and grubbing exceed 750,000 square feet (6.97 ha) without specific prior approval by the engineer. This is an important requirement. Be sure that it is followed.

QUIZ

IF a tree is designated by the Project Engineer to remain, but has branches that extend over the roadbed, what must the Contractor do?

- A. Trim all branches extending over the roadbed to give a clear height of 16 feet (5m) above the surface and treat all scars with asphalt base paint.
- B. Trim all branches to a minimum of 10 feet (3m) from the edge of pavement.
- C. Cut all branches to a height of 20 feet (6m) above the roadway, and treat scars with asphalt bass paint.

Can the Contractor use boulders to form a wall along the R/W? _____

If the contractor begins clearing and grubbing at Station 105 + 00 on a 200 feet (60m) wide project, to what station can he expose erodible earth? _____

SELECTIVE CLEARING AND GRUBBING

In some areas it is desirable to maintain the natural beauty of the environment. To achieve this, the plans will designate selective clearing and grubbing. In general, these areas are cleared and grubbing much the same as in standard clearing and grubbing, except for the following:

- ▶ Roots and other debris may be cut flush with the ground surface.
- ▶ Certain undergrowth and trees will be designated in the plans to remain for aesthetic purpose. These items must be trimmed and preserved.

The important thing to remember is that the plans will designate areas of selective clearing and grubbing; however, the Project Engineer will direct the specific activities to take place in each area. He will specify what is to be trimmed, preserved as is, or removed.

Before the start of the clearing and grubbing operation, the Project Engineer should contact the District Landscape Specialist and make arrangements for a meeting on the Project, along with Contractor. The Landscape Specialist will assist in pointing out and marking certain areas of trees and growth to be retained.

Trees and other growth to be left in place must be marked ahead of the clearing and grubbing operations so that the Contractor will not be in doubt as to what to leave in place, careful attention should be given to the plans so as prevent a conflict in the construction of side ditches, lateral ditches, sign construction or other construction that the trees and growth would hinder.

LEVELING TERRAIN

Between the clearing and grubbing limits and the construction limits, the Contractor must fill any holes or depressions, and cut down any ridge or mound. Why? So that the Department maintenance crews will be able to mow and cut these areas without danger. However, permanent ponds and other water areas designated by the Engineer do not need to be filled.

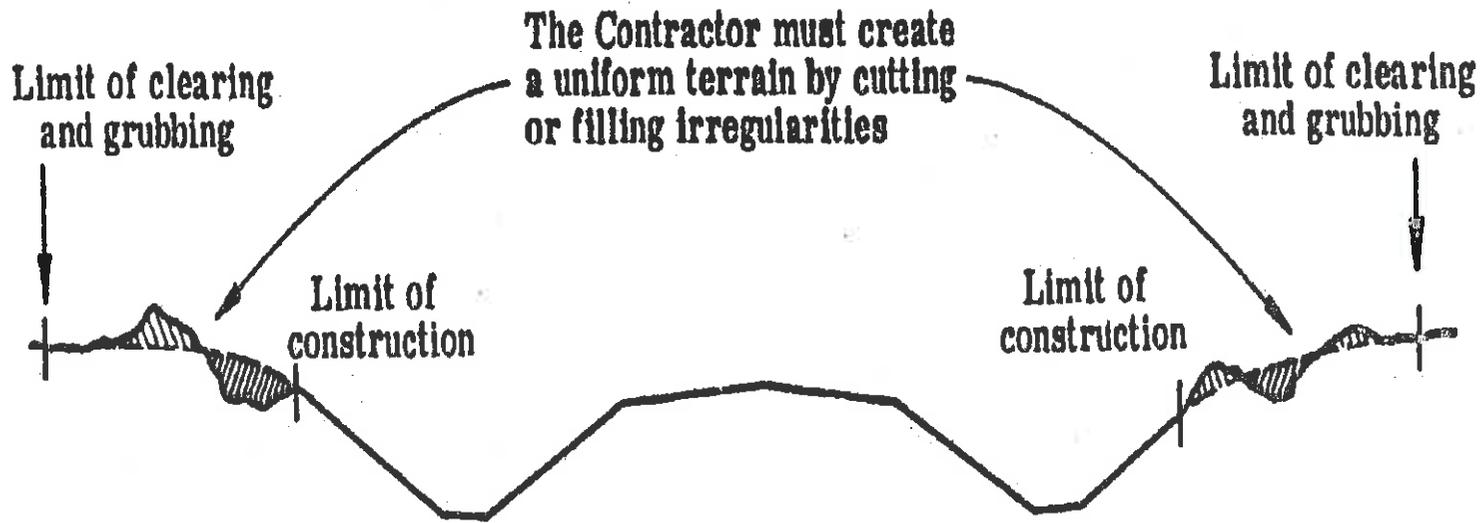

This work must be done regardless of whether the irregularities existed originally or were created by the construction work. During this final dressing of the project, there are usually a few roots to be removed and this is still Contractor=s responsibility to clear them from the project.

DISPOSAL OF MATERIALS

Disposal of debris and other materials is the responsibility of the Contractor, but there are some requirements you should know. In general, debris disposal methods must be approved by the Project Engineer. Debris should never be disposed of in a manner that would block a waterway. Some debris may be disposed of on adjacent private property when approved by the Project Engineer. But the Contractor must first obtain written permission from the property owner on whose property the debris is to be placed. The Contractor must furnish the Project Engineer with copy of the agreement before the Project Engineer will grant approval. When debris is to be disposed of on private property adjacent to the R/W, it must be at least 300 feet (90m) from the nearest project R/W line. Debris disposed of outside the R/W must not be visible from inside the R/W.

As an Inspector, you should be aware of the debris arrangements for the project. All locations and methods of disposal must be approved by the Project Engineer. Also, the Department may want certain salvable materials. The contract plans will indicate which materials, so be sure you look for them.

BURNING

If debris is to be burned, you must check the State and local laws and obeys them. State law requires a burning permit. Any burning must be under the constant care of a competent watchman, so that the surrounding property, trees and shrubs will not be jeopardized.

When burning is prohibited by law, the Contractor must dispose of debris in areas provided by him - and approved by the Project Engineer.

TIMBER AND CROPS

Any timber and crops cleared by the Contractor are his property to do with as he pleases, UNLESS the materials are diseased and must be burned. The best way to ensure compliance with this requirement is to contact the Division of Plant Industry in the Department of Agriculture before clearing begins. This is the Contractor=s responsibility. The Department of Agriculture will then send a representative who will identify diseased timber and crops and suggest precautions to be taken.

QUIZ

Which two requirements below do not apply to selective clearing and grubbing?

- A. Designated trees and brush must be preserved.
- B. All roots and debris must be removed to a depth of 1 foot (300mm).
- C. Roots and debris may be cut flush to ground surface.
- D. The ground must be plowed.

The Contractor must fill holes and depressions, and cut down ridge and mounds between the _____ and the _____ limits.

If, during terrain leveling, the Contractor comes across ridges that existed before construction began, must he cut them? _____

Are permanent ponds to be filled during terrain leveling? _____

Debris must be disposed of at least _____ from the nearest _____.

QUIZ, continued

All disposal methods must be approved by the _____.

If the Contractor wants to burn debris, what must you first be sure of _____?

What should be done to ensure that diseased timber and crops are properly disposed? _____

Before the Contractor can dispose of debris on private property, what must he do? _____

O.K. how did you do? If you need to; go back and review now. Then begin **REMOVAL OF BUILDING, STRUCTURES AND PAVEMENT.**

REMOVAL OF BUILDINGS, STRUCTURES AND PAVEMENTS

As we noted earlier, clearing and grubbing includes the removal of all parts of:

- ▶ buildings,
- ▶ existing structures, and
- ▶ existing pavements.

In this section we will cover the specifics of each.

REMOVAL OF BUILDINGS

All parts of the building, including utilities, plumbing, foundations, floors, basements, steps, connecting concrete sidewalks or other pavement, septic tanks, and any other appurtenances, must be completely removed. The methods of removal is left to the Contractor, but you must be sure that the methods do not endanger other property or utilities.

Where utilities are being removed as part of the building removal, be sure that the Contractor follows these guidelines:

- ▶ The Contractor must notify the necessary Utility Companies before any removals B so that disconnections can be made in the utility lines.
- ▶ Utilities must be removed to the point of connection with the Utility Company=s cut-in.
- ▶ After sewer connections are removed, the Contractor must construct a concrete plug at the cut-in point, unless the Utility Company elects to do their own plugging.

Where specific building are shown on the plans to be removed by others, the work included in such removals will generally have been specified as follows:

1. All building structures within the limits of the property will be removed.
2. Fences, wires and other appurtenances of the property will be removed.
3. Pipes which are party or wholly exposed above the ground will be removed.
4. Holes and cavities will be filled.
5. Rubble and debris will be removed.
6. The premises will be left in a safe, clean and sanitary condition.

Even though buildings the area to be cleared and grubbing are specified to be removed by others, you still must inspect the finished work. Many times, parts of building are left in place, for the Contractor to remove as part of cleaning and grubbing. These parts may include:

- ▶ foundations,
- ▶ curtain walls,
- ▶ concrete floors, and
- ▶ basements.

All of the parts remaining must be removed and disposed of as part of normal clearing and grubbing work.

REMOVAL OF EXISTING STRUCTURES AND EXISTING PAVEMENT

In addition to buildings, existing structures such as bridge and box culverts, and existing pavements must be removed and disposed of. Which structures are to be removed and are remain? There are three guidelines for removal:

- ▶ Structures and existing pavements designated in the plans.
- ▶ Structure within the clearing and grubbing limits.
- ▶ Structures and existing pavements which obstruct new construction.

Existing pavements include concrete pavements, sidewalks, slope and ditch pavements and curb and gutter. The Contractor can remove these structures any way he wants - but you will have to inspect the work to be sure that:

- ▶ the structures are removed completely, leaving no obstructions to new construction, existing roads or waterways.
- ▶ piling are either pulled or are cut off at least 2 feet (600 mm) below the finished ground lines.
- ▶ salvable materials are not damaged and are properly identified. Timbers should be cleaned of nails and bolts.
- ▶ concrete removed from bridges or pavements must be broken by pavement breakers, concrete saws or chipping hammers.

QUIZ

The removal of building includes the removal of utilities to the point of _____.

A sewer line is being removed as part of a building removal. What is the important point for you to remember?

A garage is removed by someone other than the Contractor, but the foundation is left in place. Who is responsible for the removal? _____

Are fences considered a part of building removal? _____

QUIZ, continued

Which of the following must be removed by the Contractor?

- A. Structures designated on the plans for removal.
- B. Structures outside the clearing and grubbing limits, but within the R/W.
- C. Existing pavements outside the clearing and grubbing limits, but which obstruct new construction.
- D. Box culverts designated for removal on the plans.

What must be done to piles supporting a removed bridge, if the pile are not pulled? _____

How did you do on the quiz? If you have any trouble, go back and review. One more point: when the U.S. Coast Guard permits work in navigable waters, the work of removing an existing structure could be inspected by the Coast Guard prior to the final acceptance by the Department.

MISCELLANEOUS OPERATIONS

There are a couple other items that may come up under clearing and grubbing: plugging water wells and removing abandoned gas tanks. These are special cases that will require special attention on your part.

PLUGGING WATER WELLS

Any water wells that are found in the R/W and which are not to remain in service must be filled or plugged. Any casing (metal or timber) that are around the well must be cut off to one foot (300mm) below the finished excavation surface or the ground line - whichever is lower.

Plugging a water well can be done a couple ways, depending on whether the well is artesian or non-artesian.

Artesian Wells

Basically, an artesian well is a well that flows naturally - without pumping. This includes wells formed by drilling to create a well.

Artesian wells are plugged by filling them with cement mortar (cement or water only). This applies to flowing and non-flowing wells, although flowing wells should be substantially stopped before plugging.

For plugging artesian wells, the Contractor should obtain advice from the Florida Bureau of Geology Department Of Environmental Regulations, and must employ a competent well-driller. The cement mixture is introduced in the well bore at a point at which it is to remain, by means of a dump-bailer or a drop-pipe through which the mixture is pumped into place. The cement mixture must not be allowed to fall freely through the water in the well.

For wells intercepting cavities or caverns, the cavernous sections may be filled with heavy mud, crushed limerock, or clean sand or gravel. Other methods may be used in filling wells which involve special or difficult problems, subject to approval by the Bureau of Geology. Should leakage around the outside of the casing appear after the well is plugged, the casing must be grouted with cement mortar to eliminate the leakage.

Non-Artesian Wells

A non-artesian well is one in which the water must be pumped out. Non-artesian wells are plugged by filling them with cement mortar, clay concrete or any other material, which will prevent surface water from draining into the well.

REMOVING ABANDONED GASOLINE TANKS

Where clearing and grubbing operations include the removal of abandoned gas stations, you must sure that the underground gasoline storage tanks are removed properly. Usually, this will require the Contractor to fill the tank with water to displace dangerous pressure and fumes, dig the tank up backfill the cavity left by it. In general then, you must be on the lookout for gas tanks and precautionary measures should be taken in removing them.

The Contractor performing the work must be certified by the Department of Environmental Regulations.

QUIZ

A casing is on a well that must be removed. What should be done to the casing if the elevation of the natural ground is 100.00 feet (30.5m) and the finished excavation surface elevation is 98.00feet (29.9m)? _____

Which of the following may be used to plug artesian water wells?

- A. Clay
- B. Cement mortar
- C. Clean sand and gravel

Which of the above may be used to plug non-artesian wells? _____

What are four steps that should be taken when removing gasoline storage tanks?

1. _____
2. _____
3. _____
4. _____

O.K., now check your answers. If you missed more than one, go back and study. Then go to MEASUREMENT AND PAYMENT.

MEASUREMENT AND PAYMENT

CLEARING AND GRUBBING

It is important to know the units of payment for clearing and grubbing, because the unit of pay will determine the type of measurement you make in the field. In general, there are two ways that a Contractor can be paid for clearing and grubbing:

- ▶ lump sum quantity, and
- ▶ by the acre (hectare).

Lump Sum Quantity

When clearing and grubbing is paid for at a lump sum price, the price covers all the clearing and grubbing work except for areas designated as special. You must keep good records of work completed, but there are no measurements to be taken.

For the monthly progress estimate (from which the Contractor gets paid), you will have to estimate the value of the work completed. For estimating partial payments, see the schedule provided in the Construction Project Administrations Manual (CPAM).

By the Acre (Hectare)

When clearing and grubbing is paid for by the acre (hectare), you will have to take measurements of the designated areas to be cleared and grubbed. You must determine the area and convert it to acres (hectare). Measurement of these areas should be done after the work has been inspected and accepted.

No Direct Payment

In some contracts, there is no direct payment for clearing grubbing. This means that you will not have to take any measurements, but you will still be required to keep proper documentation.

REMOVAL OF EXISTING STRUCTURES

If clearing and grubbing does not include removal of existing structures, then these will be paid for as each is removed. You will not need to measure anything - just inspect and document.

REMOVAL OF EXISTING PAVEMENT

Existing pavement is measured before its removal. The pavement for this work is for the area in square yards or (square meters) that is removed and disposed of the Contractor. For irregular sections such as curb and gutter, will be the area as projected to an approximate horizontal plane, as shown below:

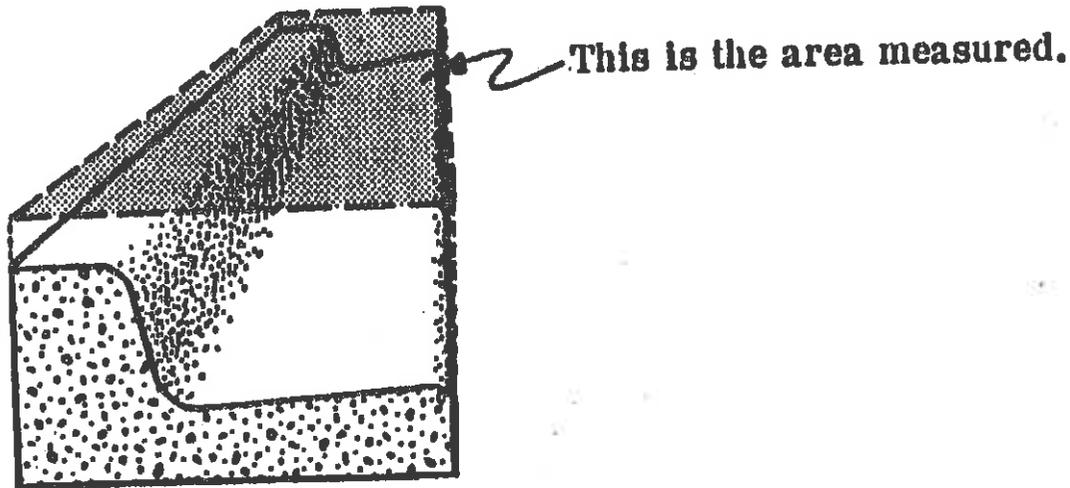

Where the removal of pavement is necessary only for the construction of drainage structures, these pavement areas must not be included in your measurements.

PLUGGING WATER WELLS

Contracts may contain items for plugging water wells. In these cases, each well will have a contract unit-price. You will not measure anything, only document plugging.

If wells are encountered unexpectedly, then plugging may be required and paid for as extra work. Check with Project Engineer for your responsibilities.

QUIZ

What ARE TWO WAYS A Contractor can be paid for clearing and grubbing?

What must you do if the Contractor is not paid directly for clearing and grubbing?

The Contractor removes a concrete pavement 18 feet (5.5m) long, 12 feet (3.7m) wide and 9 inches (230mm) thick.
What is the pay quantity?

Must you measure water wells that are plugged?

DOCUMENTATION

As we mentioned in the previous section, one of your most important inspection duties will be to maintain accurate records. For clearing and grubbing work, the document that you will keep is the Daily Report of Construction.

The Daily Report of Construction was discussed earlier in this text, under Utility Relocations Inspection, but we will discuss the basics again here and show you sample reports.

Here are the things you must document:

- ▶ **project identification information;**
- ▶ **weather conditions;**
- ▶ **items of work, locations and quantities;**
- ▶ **descriptions of the work;**
- ▶ **Contractor personnel, equipment and materials; and**
- ▶ **remarks and working hours.**

Study this report, then try the quiz on the next page.

STATE OF FLORIDA DEPARTMENT OF TRANSPORTATION
DAILY REPORT OF CONSTRUCTION

FORM 702-610-13
 CONSTRUCTION - 05/89
 Page 1 of 2

Select One:
 Subcontractor
 Contractor

DESCRIPTION OF WORK		
CONTRACTOR: Alexander Telephone, Co.		
OPERATION and LOCATION		TIME (AM/PM?)
Relocating telephone cables at poles at base Sta. 501 + 00.11 and Sta 503 + 00.11		BEGINNING: 7:30am ENDING: 4:00pm

PERSONNEL	NO.	HOURS WORKED	MATERIALS RECEIVED
SUPT.	1	8	
FOREMAN	1	8	
SKILLED	2	8	
SEMI SKILLED	3	8	
COMMON	1	8	
TRAINEE			

EQUIPMENT (ACTIVE/IDLE)											
A	I		A	I		A	I				
		AIR COMPRESSOR			CULTIVATOR			POWER BROOM			TRUCK, DUMP
		AIR HAMMER			DRAGLINE			PUMP			TRUCK, FLATBED
		ASPHALT PAYER			EARTH MOVER			ROLLER, STEEL WHEEL			TRUCK, GREASE
		ASPHALT DISTRIBUTOR			FRONTEND LOADER			ROLLER, TRAFFIC			TRUCK, LANE STRIPING
		BACCHOE			HAND LINER			ROLLER, VIBRATORY	4		TRUCK, PICKUP
		BULLDOZER			HARROW			ROTARY TILLER/MIXER			TRUCK, WATER
		CONCRETE BUCKET			GENERATOR			SPREADER, BOX			WELLPOINT SYSTEM
		CONCRETE SAW	1		MECHANICAL TAMPER			SPREADER, SEED			
		CONCRETE SCREED			MILLING MACHINE			SPREADER, FERTILIZER	2		utility truck
		CONCRETE VIBRATOR			MOTOR GRADER			TRACTOR, FARM			
		CRANE, CRAWLER			MULCHER			TRANSPORT	1		automobile
		CRANE, TRUCK			PILE DRIVER & HAMMER			TRUCK, BUCKET			

3-32A

ESTIMATED CONTRACT QUANTITY INCREASES TODAY			
ITEM NO.	ITEM	QUANTITY	REMARKS AND CALCULATIONS

FIN PROJECT NO.: 200011-1501	F.A. PROJECT NO.: N/A	CONTRACT NO.: 10235	DATE: 4/2/1999	DAY OF WEEK: MONDAY	CONTRACT DAY: 2
---------------------------------	--------------------------	------------------------	-------------------	------------------------	--------------------

FIN PROJECT NO.: 100001-15201	F.A. PROJECT NO.: FA-49-88	CONTRACT NO.: 16,250	DATE: 8/5/1999	DAY OF WEEK: THURSDAY	CONTRACT DAY: 3
----------------------------------	-------------------------------	-------------------------	-------------------	--------------------------	--------------------

WEATHER CONDITIONS: Clear Partly Cloudy Heavy Clouds Fog

TEMPERATURE: 85 High 68 Low Temperature Restriction Specification No. _____

WIND: None Slight Strong

RAIN: None Light Heavy Showers

RAIN DURATION: 0-2 Hrs. 2-4 Hrs. 4-6 Hrs. All Day

WORKING CONDITIONS: Excellent Good Fair Poor Bad

DURATION OF ACCEPTABLE CONDITIONS: Acceptable All Day More Than 50% of Work Day Less than 50% of Work Day Unacceptable All Day

SOIL CONDITION: Dry Wet Extremely Wet

EFFECTS OF WEATHER ON MAJOR WORK ITEMS (CHECK CONTROLLING ITEMS):

Major and/or Controlling Work Items	No Effect All Day	Effectd Less Than 50% of Work Day	Effectd More Than 50% of Work Day	No Work All Day
Clearing and Grubbing	<input checked="" type="radio"/>	<input type="radio"/>	<input type="radio"/>	<input type="radio"/>
_____	<input type="radio"/>	<input type="radio"/>	<input type="radio"/>	<input type="radio"/>
_____	<input type="radio"/>	<input type="radio"/>	<input type="radio"/>	<input type="radio"/>
_____	<input type="radio"/>	<input type="radio"/>	<input type="radio"/>	<input type="radio"/>
_____	<input type="radio"/>	<input type="radio"/>	<input type="radio"/>	<input type="radio"/>
_____	<input type="radio"/>	<input type="radio"/>	<input type="radio"/>	<input type="radio"/>

GENERAL COMMENTS:

Contractor disposed of roots and debris at a private location outside of RAW

VISITORS: _____

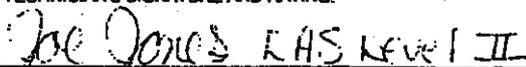
TECHNICIAN'S SIGNATURE AND RATING:  RAS Level II	HOURS AT JOB SITE:	TOTAL HOURS:
	FROM <u>8 am</u> TO <u>5 pm</u>	<u>8</u>

ENGINEER IN CHARGE (NAME, BANK AND INITIALS):

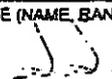
S. Smith, EAS Level III 

3-32B

QUIZ

The question below refers to the Daily Report of Construction shown on the previous page.

This Report was submitted for what date? _____

How many pay items are covered by this Report? _____

How many personnel did the Contractor have on the job? _____

Between what stations did the Contractor work on that day? _____

Where did the Contractor dispose of the debris he cleared? _____

QUIZ

Use the data below to complete the Daily Report on the next page. The work takes place the day after the work shown on page 3-32, on the same project.

- ▶ The Contractor continued clearing and grubbing. He cleared 3 more acres of R/W between stations 360 + 00 and 370 + 00, plowed the surface and disposed of all debris as before.

- ▶ The weather was fair, with a high of 85EF and as low 68EF. The work day was from 8 a.m. to 5 p.m.

- ▶ The Contractor's work force included a superintendent, a foreman, 3 equipment operators (skilled), a dump-truck driver (semi-skilled) and 10 laborers. All the equipment remained the same.

- ▶ As the Inspector, you worked 8 hours on the job, from 8 a.m. to 5 p.m. (one hour for lunch).

QUIZ, continued

When you have completed this Report, compare it to one on the next page.

STATE OF FLORIDA DEPARTMENT OF TRANSPORTATION
DAILY REPORT OF CONSTRUCTION

FORM 700-010-12
 CONSTRUCTION - 05/99
 Page 1 of 2

3-35A

DESCRIPTION OF WORK							
CONTRACTOR:							
OPERATION and LOCATION						TIME (AM/PM?)	
						BEGINNING	ENDING
PERSONNEL	NO.	HOURS WORKED	MATERIALS RECEIVED				
SUPT.							
FOREMAN							
SKILLED							
SEMI SKILLED							
COMMON							
TRAINEE							
EQUIPMENT (ACTIVE/IDLE)							
A	I	A	I	A	I	A	I
	AIR COMPRESSOR		CULTIPACTOR		POWER BROOM		TRUCK, DUMP
	AIR HAMMER		DRAGLINE		PUMP		TRUCK, FLATBED
	ASPHALT PAVER		EARTH MOVER		ROLLER, STEEL WHEEL		TRUCK, GREASE
	ASPHALT DISTRIBUTOR		FRONTEND LOADER		ROLLER, TRAFFIC		TRUCK, LANE STRIPING
	BACKHOE		HAND LNER		ROLLER, VIBRATORY		TRUCK, PICKUP
	BULLDOZER		HARROW		ROTARY TILLER/RODDER		TRUCK, WATER
	CONCRETE BUCKET		GENERATOR		SPREADER, BOX		WELLPOINT SYSTEM
	CONCRETE SAW		MECHANICAL TAMP		SPREADER, SEED		
	CONCRETE SCREED		MILLING MACHINE		SPREADER, FERTILIZER		
	CONCRETE VIBRATOR		MOTOR GRADER		TRACTOR, FARM		
	CRANE, CRAWLER		MULCHER		TRANSPORT		
	CRANE, TRUCK		PILE DRIVER & HAMMER		TRUCK, BUCKET		
ESTIMATED CONTRACT QUANTITY INCREASES TODAY							
ITEM NO.	ITEM	QUANTITY	REMARKS AND CALCULATIONS				
FIN PROJECT NO.:	F.A. PROJECT NO.:	CONTRACT NO.:	DATE:	DAY OF WEEK:	CONTRACT DAY:		

DISTRIBUTION: ORIGINAL - PROJECT FILE
 COPY - CONTRACTOR (AS REQUESTED)
 COPY - DISTRICT CONSTRUCTION ENGINEER

COPY - PRIMA (IF A OVERSIGHT)

FIN PROJECT NO.:	F.A. PROJECT NO.:	CONTRACT NO.:	DATE:	DAY OF WEEK:	CONTRACT DAY:
------------------	-------------------	---------------	-------	--------------	---------------

WEATHER CONDITIONS: Clear Partly Cloudy Heavy Clouds Fog

TEMPERATURE: _____ High _____ Low Temperature Restriction Specification No. _____

WIND: None Slight Strong

RAIN: None Light Heavy Showers

RAIN DURATION: 0-2 Hrs. 2-4 Hrs. 4-6 Hrs. All Day

WORKING CONDITIONS: Excellent Good Fair Poor Bad

DURATION OF ACCEPTABLE CONDITIONS: Acceptable All Day More Than 50% of Work Day Less than 50% of Work Day Unacceptable All Day

SOIL CONDITION: Dry Wet Extremely Wet

EFFECTS OF WEATHER ON MAJOR WORK ITEMS (CHECK CONTROLLING ITEMS):

Major and/or Controlling Work Items	No Effect All Day	Effected Less Than 50% of Work Day	Effected More Than 50% of Work Day	No Work All Day
_____	<input type="radio"/>	<input type="radio"/>	<input type="radio"/>	<input type="radio"/>
_____	<input type="radio"/>	<input type="radio"/>	<input type="radio"/>	<input type="radio"/>
_____	<input type="radio"/>	<input type="radio"/>	<input type="radio"/>	<input type="radio"/>
_____	<input type="radio"/>	<input type="radio"/>	<input type="radio"/>	<input type="radio"/>
_____	<input type="radio"/>	<input type="radio"/>	<input type="radio"/>	<input type="radio"/>
_____	<input type="radio"/>	<input type="radio"/>	<input type="radio"/>	<input type="radio"/>

GENERAL COMMENTS:

VISITORS: _____

TECHNICIAN'S SIGNATURE AND RATING:	HOURS AT JOB SITE:	TOTAL HOURS:
	FROM _____ TO _____	

ENGINEER IN CHARGE (NAME, RANK AND INITIALS):

3-35B

QUIZ, continued

Your Report should be similar to this one - neat, easy to read, accurate, and signed.

Select One:
 Subcontractor
 Contractor

STATE OF FLORIDA DEPARTMENT OF TRANSPORTATION
DAILY REPORT OF CONSTRUCTION

CONTRACTOR: **F.M. Johnson and Son** DESCRIPTION OF WORK

OPERATION and LOCATION	TIME (AM/PM?)	
	BEGINNING	ENDING
Cleared trees - plowed earth grubbing 18" below surface Sta. 360 + 00 - 370 + 00	8:00am	5:00pm

PERSONNEL	NO.	HOURS WORKED	MATERIALS RECEIVED
SUPT.	1	8	
FOREMAN	1	8	
SKILLED	3	8	
SEMI SKILLED	1	8	
COMMON	10	8	
TRAINEE			

EQUIPMENT (ACTIVE/IDLE)							
A	I	A	I	A	I	A	I

ESTIMATED CONTRACT QUANTITY INCREASES TODAY			
ITEM NO.	ITEM	QUANTITY	REMARKS AND CALCULATIONS
110-2	Clearing and grubbing	3.0 Ac.	Sta. 360 + 00 - 370 + 00
FIN PROJECT NO.: 100001-15201	F.A. PROJECT NO.: FA-49-88	CONTRACT NO.: 16,250	DATE: 8/5/1999
			DAY OF WEEK: THURSDAY
			CONTRACT DAY: 3

3-36A

DISTRIBUTION ORIGINAL - PROJECT FILE
 COPY - CONTRACTOR (AS REQUESTED)
 COPY - DISTRICT CONSTRUCTION ENGINEER

COPY - FHWA (IF A OVERSIGHT)

FIN PROJECT NO.: 100001-15201	F.A. PROJECT NO.: FA-49-88	CONTRACT NO.: 16,250	DATE: 8/5/1999	DAY OF WEEK: THURSDAY	CONTRACT DAY: 3
----------------------------------	-------------------------------	-------------------------	-------------------	--------------------------	--------------------

WEATHER CONDITIONS: Clear Partly Cloudy Heavy Clouds Fog

TEMPERATURE: 85 High 68 Low Temperature Restriction Specification No. _____

WIND: None Slight Strong

RAIN: None Light Heavy Showers

RAIN DURATION: 0-2 Hrs. 2-4 Hrs. 4-6 Hrs. All Day

WORKING CONDITIONS: Excellent Good Fair Poor Bad

DURATION OF ACCEPTABLE CONDITIONS: Acceptable All Day More Than 50% of Work Day Less than 50% of Work Day Unacceptable All Day

SOIL CONDITION: Dry Wet Extremely Wet

EFFECTS OF WEATHER ON MAJOR WORK ITEMS (CHECK CONTROLLING ITEMS):

Major and/or Controlling Work Items	No Effect All Day	Effectd Less Than 50% of Work Day	Effectd More Than 50% of Work Day	No Work All Day
Clearing and Grubbing	<input checked="" type="radio"/>	<input type="radio"/>	<input type="radio"/>	<input type="radio"/>
_____	<input type="radio"/>	<input type="radio"/>	<input type="radio"/>	<input type="radio"/>
_____	<input type="radio"/>	<input type="radio"/>	<input type="radio"/>	<input type="radio"/>
_____	<input type="radio"/>	<input type="radio"/>	<input type="radio"/>	<input type="radio"/>
_____	<input type="radio"/>	<input type="radio"/>	<input type="radio"/>	<input type="radio"/>
_____	<input type="radio"/>	<input type="radio"/>	<input type="radio"/>	<input type="radio"/>

GENERAL COMMENTS:

Contractor disposed of mnts and debris at a private location outside of ROW

VISITORS: _____

TECHNICIAN'S SIGNATURE AND RATING: <i>Joe Jones EAS Level II</i>	HOURS AT JOB SITE:	TOTAL HOURS:
	FROM <u>8am</u> TO <u>5pm</u>	<u>8</u>

ENGINEER IN CHARGE (NAME, BANK AND INITIALS):

S. Smith, EAS Level III *SS*

3-36B

ANSWERS TO QUESTIONS

Page 3-8

- ▶ B and D
- ▶ C
- ▶ E and the lower roots of D
- ▶ A and F

Page 3-9

- ▶
 1. Remove all roots, etc. At least 1 foot (300mm) below ground.
 2. plow to 6" (150mm) below ground
 3. remove exposed roots to 1 foot (300mm) below ground
- ▶
 - A. Cut off roots below finished excavation
 - B. Remove
 - C. Leave in place

Page 3-12

- ▶ A
- ▶ no
- ▶ Sta. 142 + 50

ANSWERS TO QUESTIONS, continued

Page 3-17

- ▶ B; D
- ▶ clearing and grubbing; construction
- ▶ yes
- ▶ no
- ▶ 300 feet (90m); R/W

Page 3-18

- ▶ Project Engineer
- ▶ state and local laws allow it
- ▶ Contact Division of Plant Industry before clearing
- ▶ obtain written permission from owner and the Project Engineers approval

Page 3-22

- ▶ connection with Utility=s tie-in
- ▶ concrete plug must be constructed
- ▶ contractor
- ▶ yes

Page 3-23

- ▶ A ; C ; D
- ▶ cut off 2 feet (600 mm) below finished ground

Page 3-26

- ▶ remove casing to elevation 97.00 feet (29.6m)
- ▶ B
- ▶ A; B
- ▶ 1. Check contractor=s permit
- ▶ 2. Fill with water
- ▶ 3. Dig up tank
- ▶ 4. Backfill

Page 3-30

- ▶ lump sum; by the acre (hectare)
- ▶ inspect the work and document it
- ▶ 24 sq.yds. (20.4m⁵)
- ▶ no

Page 3-33

- ▶ 8-4-99
- ▶ 3
- ▶ 21
- ▶ Sta. 342 + 00 to 360 + 00
- ▶ private location outside R/W

CHAPTER FOUR

Basic Information for Miscellaneous Concrete Structures

CONTENTS

TYPES OF STRUCTURES	4-2
Barrier Wall	4-3
Curb and Gutter	4-4
Sidewalk	4-4
Traffic Separator	4-5
Ditch Pavement	4-5
Slope Pavement	4-6
REVIEW OF PLANS	4-8
ANSWERS TO QUESTIONS	4-12

BASIC INFORMATION FOR MISCELLANEOUS CONCRETE STRUCTURES

TYPES OF STRUCTURES

Miscellaneous concrete structures include several items that we see every day along the highways and roads:

- < barrier wall,
- < curb and gutter,
- < sidewalk,
- < traffic separator,
- < ditch pavement, and
- < slope pavement.

Each structure serves a different purpose. Before we begin a discussion of the inspection of each structure, let's briefly look at the structures and how they are used on the road.

BARRIER WALL

Barrier wall is generally constructed in medians or between traffic lanes, to act as a safety barrier and/or to reduce glare. Barrier wall also may be constructed on a bridge to serve as handrail, or along side a roadway to aid in noise reduction.

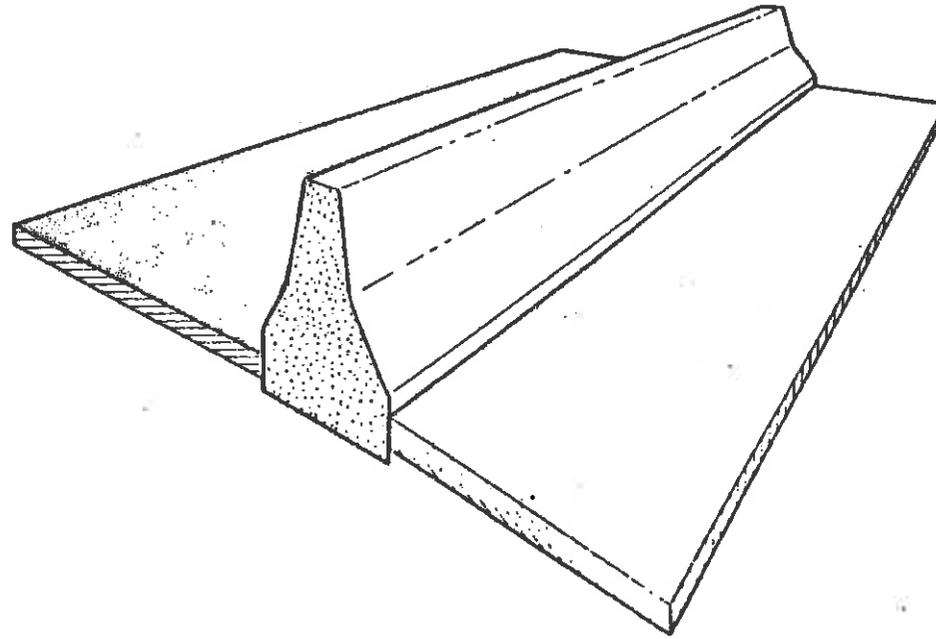

CURB AND GUTTER

Curb and gutter is designed to drain water to inlets, or other collection points. Although the term implies two separate parts, a curb and gutter is one structure.

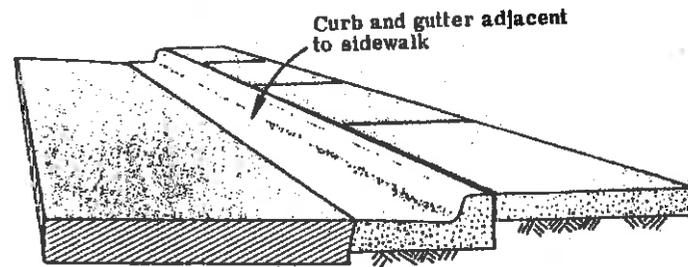

SIDEWALK

Sidewalk is used by pedestrian traffic beside roadways and in traffic islands. Sidewalk can be constructed adjacent to curb and gutter or apart.

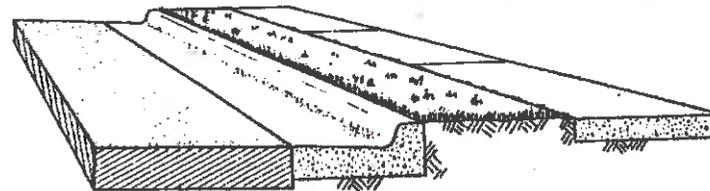

Sidewalk separated from curb and gutter by utility strip

TRAFFIC SEPARATOR

Basically, traffic separator is a low safety barrier between traffic lanes used to control and channelize traffic.

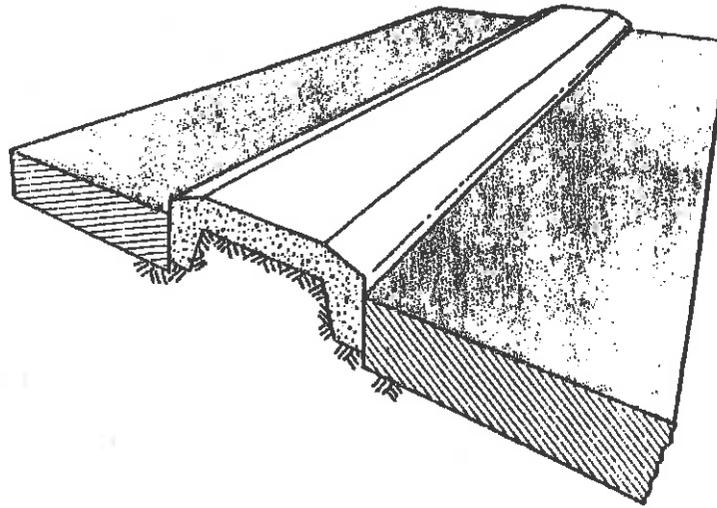

DITCH PAVEMENT

Ditch pavement is placed in areas where erosion prevention is needed. It is usually constructed to meet the drainage needs of the area.

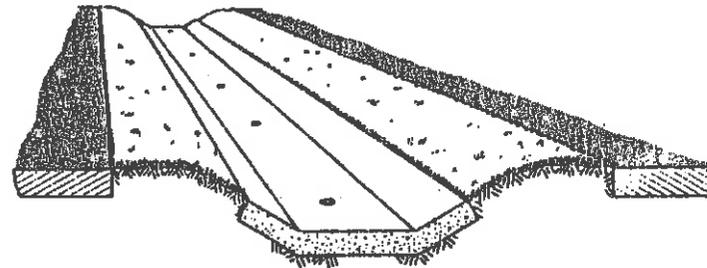

SLOPE PAVEMENT

Slope pavement is placed at bridge ends. It is one of several types of slope treatment that serve three main purposes:

1. Slope pavement provides a uniform, pleasing appearance.
2. Slope pavement reduces future maintenance problems, such as mowing.
3. Slope pavement is placed in areas such as under bridges where vegetation will not grow.

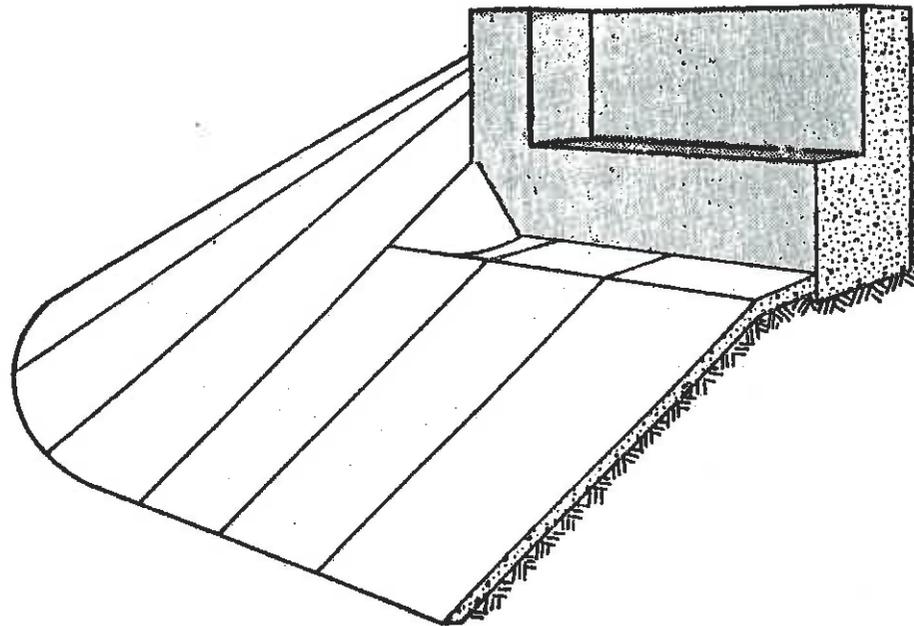

QUIZ

Match the structures with the purposes below. There may be more than one purpose for each structure.

<u>STRUCTURE</u>	<u>PURPOSE</u>
1. . Barrier wall	A. Carry pedestrian traffic.
2. . Curb and gutter	B. Reduce maintenance under bridges.
3. . Sidewalk	C. Act as a safety barrier.
4. . Traffic separator	D. Channelize and control traffic.
5. . Ditch pavement	E. Used as bridge handrail.
6. . Slope pavement	F. Drain water from pavement to inlet.
	G. Prevent erosion in ditches.

O.K. That was simple enough. If you need to, review the previous pages, then go on to REVIEW OF PLANS.

REVIEW OF PLANS

One of the basic skills you must have to do a good job inspecting miscellaneous structures is the ability to read contract plans. Some of the information you will need is found in the plans - typical sections, plan and profile sheets, bridge layout sheets, etc.; however, most of the information will be found on the Standard Index sheets in the Roadway and Traffic Design Standards.

The Appendix to this course is a Plan Book, which contains the standard drawings that you will use to inspect miscellaneous structures. You should be generally familiar with plan sheets -- from the Contract Plan Reading course -- so open your plan book and look over the sheets. When you think you're ready, try the quiz, which follows. The quiz covers basic information, so don't worry about studying the plans in detail. Just look them over to orient yourself.

QUIZ

List the Standard Index numbers for:

barrier wall _____
curb and gutter _____
traffic separator _____
ditch pavement _____
concrete sidewalk _____

Why do you think slope pavement is not a standard detail? _____

What are the minimum dimensions for concrete ditch pavement?

Depth of toe wall _____
Thickness of toe wall _____
Thickness of ditch pavement _____

What is the standard thickness for concrete sidewalk? _____

What is the standard thickness for a concrete driveway? _____

QUIZ, continued

What is the maximum spacing allowed between contraction joints in concrete ditch pavement? _____
_____ (Note: Check the general notes.)

In this course we will discuss Type F concrete curb and gutter. What is the cross slope of the gutter when Type F curb and gutter is used on the high side of the pavement? _____

For a Type I concrete traffic separator, does the stabilized subgrade extend under the traffic separator or just under the pavement? _____

How many sheets comprise the median barrier detail? _____

Can barrier wall be used when the grades of the pavement on opposite sides of the wall are significantly different? _____

How did you do? You should be able to find all of the answers to the quiz questions in the Standard Indexes. Be sure you can find them before you begin the next chapter.

The remainder of this course will deal specifically with the inspection of the construction of each structure we've mentioned -- from subgrade preparation, staking and forming for concrete-to-concrete placement, joints, finishing, payment and special problems or considerations. Many of the important points are the same for all structures, and where this is the case we will refer to previous discussions. So be sure to follow three simple guidelines for making the best use of this course:

- ▶ Take the time to study. Don't just read -- study.
- ▶ Study to understand. Don't memorize everything -- study well enough to understand and remember important points.
- ▶ Use the quizzes to guide your progress. If you cannot answer all the Quiz questions easily, restudy until you can, or get help from someone.

ANSWERS TO QUESTIONS

Page 4-7

- ▶ 1. C, E
- ▶ 2. F
- ▶ 3. A
- ▶ 4. D
- ▶ 5. G
- ▶ 6. B

Page 4-10

- ▶ 25 feet
- ▶ same as the adjacent pavement
- ▶ under separator
- ▶ 3
- ▶ yes

Page 4-9

- ▶ 410
- ▶ 300
- ▶ 302
- ▶ 281
- ▶ 282 and 515
- ▶ different design for each bridge
- ▶ 24 inches
- ▶ 6 inches
- ▶ 3 inches
- ▶ 4 inches
- ▶ 6 inches

CHAPTER FIVE

Barrier Wall

CONTENTS

SEQUENCE	5-2
ALIGNMENT CONTROL	5-3
SUBGRADE PREPARATION	5-6
FORMS	5-7
JOINTS	5-9
Expansion Joints	5-9
Contraction Joints	5-9
Construction Joints	5-9
Inspection	5-9
CONCRETING	5-13
FINISHING	5-14
CURING	5-16
ANSWERS TO QUESTIONS	5-17

5

BARRIER WALL

SEQUENCE

The construction of a barrier wall is the same as any concrete construction:

1. Alignment is staked or marked.
2. A subgrade is excavated, leveled and prepared.
3. Forms are set for the concrete.
4. The concrete is placed and joints are properly located.
5. The concrete is finished with a Class 3 finish.

In this chapter we will cover each of these steps and your inspection duties.

ALIGNMENT CONTROL

There are two types of alignment -- horizontal and vertical (line and grade).

Line and grade for a barrier wall is controlled by stakes, offset from the centerline of the wall. The control points consist of:

- < an offset distance to the wall's centerline,
- < a fill distance to the top of the wall, and
- < a station number.

The mark usually is a tack or cross, chiseled in the pavement, circled in paint, and accompanied by the control data.

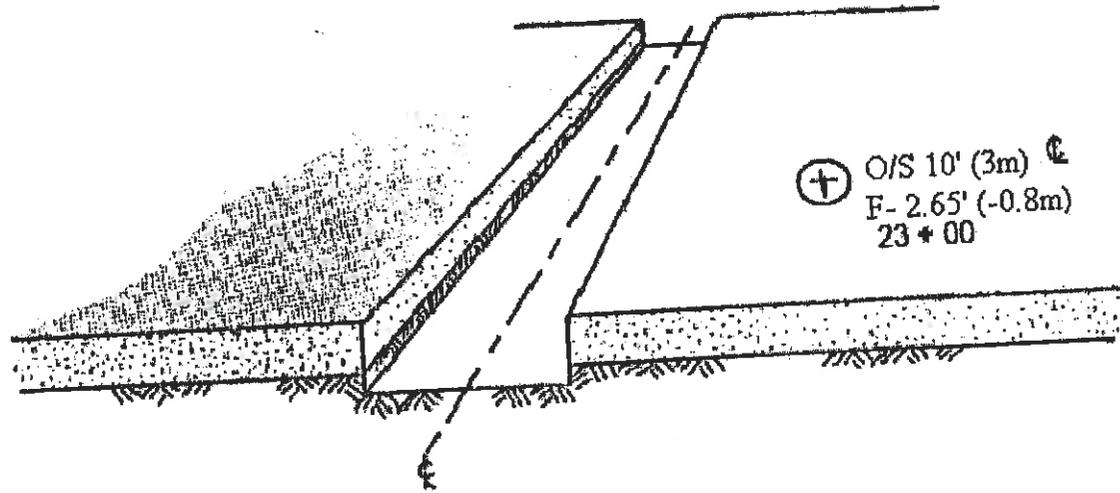

The mark in the illustration to the right is located at station 23 + 00, 10 feet (3m) from the wall centerline, 2.65 feet (0.8m) below the top of the wall.

Control marks are placed about every 25 feet (7.6m).

The diagram at the right shows the dimensions that can be determined from the control mark.

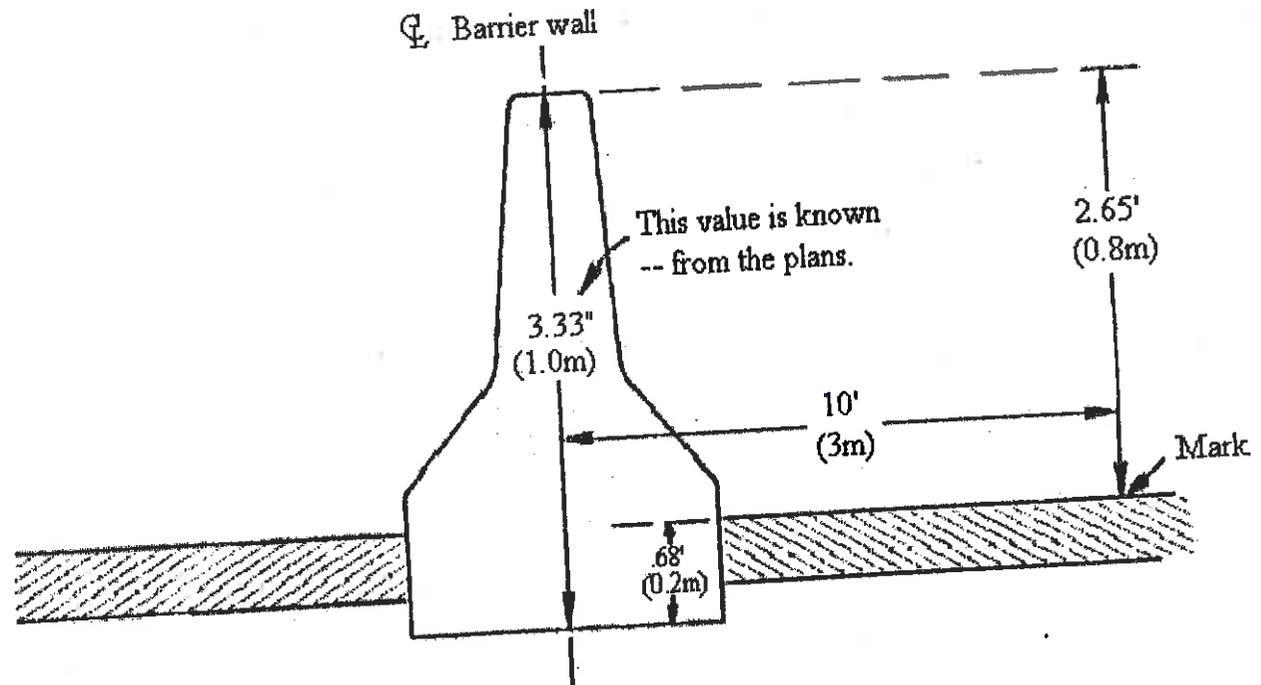

QUIZ

From the control mark shown on the right, complete the diagram below.

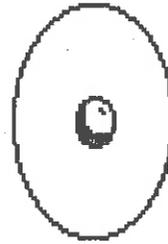

o/s 10' (3m) E
F-2.65' (-0.8m)
25 + 50

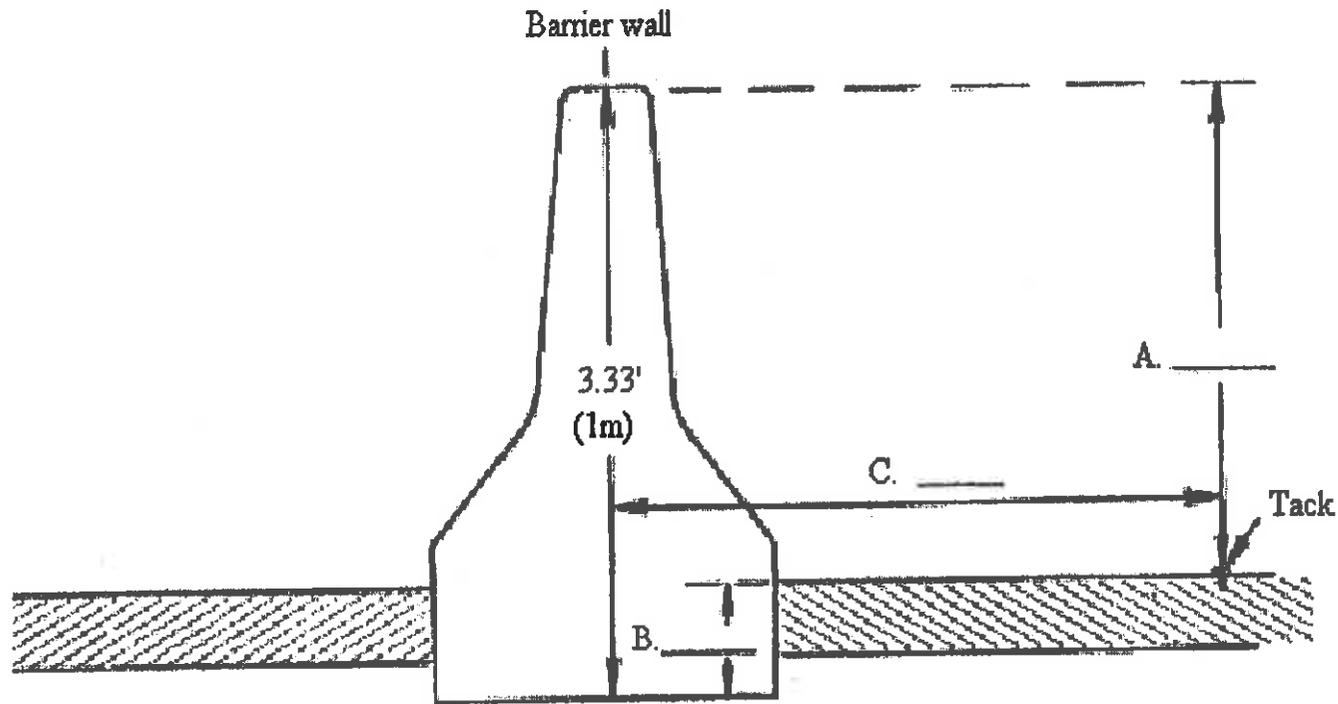

5-5

SUBGRADE PREPARATION

The first step in the construction of a barrier wall is the excavation and preparation of the subgrade. You will have two inspection duties.

1. Check the grade of the finished subgrade.
2. Inspect the condition of the subgrade.

You can check grade with a carpenter's level and a ruler. For example, look back to page 5-4. Here is how you would check the grade of that subgrade.

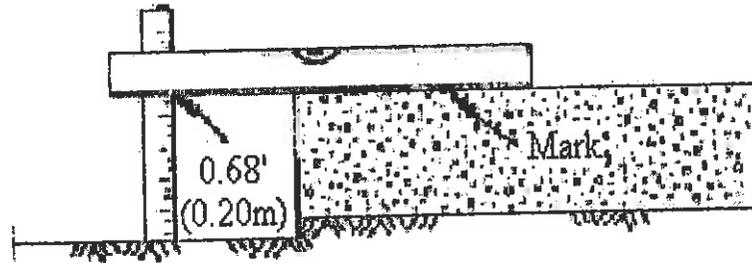

When you inspect the condition of the subgrade, you will want to see that the subgrade is:

- < uniform -- with no high or low spots.
- < damp -- if it's dry, wet it, then tamp.

The last is important. The subgrade must be wet just before concrete is placed. Otherwise, the dry subgrade will draw the moisture out of the concrete.

NOTE: The top 12 inches (300mm) of subgrade must be compacted to 100% of density.

FORMS

When the subgrade is prepared, the Contractor can begin setting forms for the concrete. As an Inspector, you should check the forms to be sure that they are metal or timber with form liners, and that they are in good condition -- no dents, bends, cracks or protruding pieces -- and that they are the proper dimensions.

There are a couple of specific things you must check when the forms are placed:

- < You must check the line and grade of the forms. You can use the control marks or stakes to check the offset and the elevation of the top of wall.
- < You must check the chamfer strips placed at the corners. Be sure that the strips are straight and at the proper height on the forms.

Barrier wall forms are shaped with tops that are much narrower than the bottoms. When the concrete is placed, there is a tendency for the concrete to exert an upward pressure causing the forms to "float" on the concrete. To counter this, the Contractor may use a suitable method to secure the forms or exercise extreme care in placing the concrete to minimize this occurrence.

One more point: some Contractors are using the Slip Form Method for constructing barrier wall. This method involves a machine that extrudes a barrier already formed as it is placed and no forms are necessary. For this method, the subgrade is prepared the same way as with the conventional forms method. Also, the staking remains the same.

In this operation, the machine follows a controlled stringline and it must be checked for grade and alignment. With this method, it is very important to check dimensions on the barrier wall.

QUIZ

What are two inspection duties you have when the contractor completes excavation for a barrier wall base?

1. _____
2. _____

Before concrete can be placed on a subgrade, the subgrade must be _____ and _____

There are two important inspection points for barrier wall forms. What are they?

1. _____
2. _____

JOINTS

Concrete expands and contracts as temperature goes up and down. Expansion and contraction joints are placed or formed in fresh concrete to relieve the stresses created by changes in temperature. At times, contraction joints may also be sawed.

EXPANSION JOINTS

Expansion joints are spaces between section of concrete that are filled with some type of filler material. When concrete expands, the filler material is compressed, avoiding buckling in the concrete sections. Expansion joint filler material is put in place just before concrete is placed in the forms.

CONTRACTION JOINTS

Contraction joints (called transverse joints) are cracks caused by sections of concrete contracting and pulling away from each other. Contraction joints are not random, however, the concrete can be weakened in certain areas -- by making a groove in the plastic concrete -- so that the contraction cracks will occur where they are needed. Cast-in-place barrier wall normally will be a continuous pour without transverse contraction joints.

CONSTRUCTION JOINTS

Construction joints are formed between sections of concrete placed at different times. Only one horizontal construction joint is allowed in a barrier wall -- between the footing and the wall.

INSPECTION

You must be sure that expansion and contraction joints are spaced and placed properly.

QUIZ

Refer to Standard Index 410 to answer the questions below.

When are transverse contraction joints used in a continuous wall pour? _____

What is the spacing of contraction joints in barrier wall placed adjacent to concrete pavement? _____

Expansion joints are called for at two locations: (1) at existing or proposed expansion joints in concrete slabs where the wall is an integral part of the concrete slab; and (2) at _____.

Does the precast barrier wall require transverse joints? _____

DISCUSSION OF QUIZ

Here are explanations of the quiz questions.

Contraction joints are referred to as transverse joints on the Standard Index because they appear at a right angle with the roadway centerline.

Expansion joints are not shown in the typical sections, but they are mentioned under the General Notes in the middle of the sheet.

The barrier wall base width is two (2) feet (610mm) wide, standard.

QUIZ, continued

These questions refer to Standard Index 410 (1 of 22) lower left hand corner.

What two types of barrier wall are shown? _____ , _____

How thick is the barrier wall base? _____

Is the barrier wall reinforced or non-reinforced? _____

If the plans do not stipulate the type of wall, what option does the Contractor have? _____

CONCRETING

Concrete construction is similar for every structure. Here are the important points to remember:

- ▶ Be sure that the base is wet before any concrete is placed.
- ▶ Check the form dimensions and grades one more time.
- ▶ Collect delivery tickets from the concrete suppliers.
- ▶ Perform the proper sampling and testing for the type of concrete, place.

For information on these tests, consult the Department's Sampling, Testing and Reporting Guide.

- ▶ Check the finished product carefully. The Contractor's finishers should use 10-foot (3.048m) straightedges to finish the tops of the barrier wall. As they straightedge, you should be looking for high or low spots. A straight, smooth line along the top of a barrier wall is very important because the public will only notice a crooked wall.

FINISHING

Concrete barrier wall must be given a Class 3 finish, which consists of:

1. Finishing the top of the barrier wall while the concrete is plastic, to a surface texture as similar to the formed portion as possible. In most cases, this will mean that the finishers should use a steel trowel to obtain a smooth, dense surface.
2. Exposing joint filler in expansion joints so that concrete does not cover the joints and set.
3. After removing the forms, the finishers must remove any metal ties or fins and smooth the entire surface. They also must fill any holes, honeycombs, chips or spalls. The cavities must be cleaned, soaked with water and then pointed (filled) with mortar.
4. On slip form walls, it is basically point and patch with no rubbing.

QUIZ

On slip form walls, finishing does not require _____

Who straightedges barrier wall? _____

Does the top of a barrier wall get a smoother finish than the sides? _____

You must be sure that joint filler material in the expansion joint is _____
after form removal.

CURING

The top of the barrier wall must be cured either by the use of a curing compound or wet burlap for a period of 72 hours. When the forms are left in place for 72 hours or longer after the concrete has been poured, then no additional curing is required for the wall sides. When the barrier wall is slip-formed, the top and sides must be cured. This is generally accomplished by the application of a membrane curing compound applied as soon as the finishing is completed. Other approved methods may be used.

That's about it for concrete barrier wall. Next we will discuss curb and gutter. Many of the inspection duties are similar, but some of the work is different, so be sure to read the chapter carefully.

ANSWERS TO QUESTIONS

Page 5-5

- ▶ A. 2.65 ft. (0.80m)
- ▶ B. 0.68 ft. (0.20m)
- ▶ C. 10 ft. (3m)

Page 5-8

- ▶ 1. Check condition of subgrade
- ▶ 2. Check density of subgrade
- ▶ Uniform; damp
- ▶ 1. Chamfer strips
- ▶ 2. Line and grade

Page 5-10

- ▶ Never
- ▶ Same as pavement joints
- ▶ bridge ends
- ▶ Yes

Page 5-12

- ▶ Cantilever Wall; AL@ Wall
- ▶ 12 inches (305mm)
- ▶ Reinforced
- ▶ Build either one

Page 5-15

- ▶ rubbing
- ▶ Contractor
- ▶ No, the same
- ▶ exposed

CHAPTER SIX

Curb and Gutter

CONTENTS

INTRODUCTION	6-2
TERMINOLOGY	6-3
STAKING	6-4
EXCAVATION	6-6
CONCRETE PLACEMENT	6-7
Forms	6-7
Slip Form	6-9
Placing Concrete	6-12
Contraction Joints	6-13
Expansion Joints	6-14
Finishing	6-16
Curing	6-17
BACKFILLING	6-18
MEASUREMENT	6-18
ANSWERS TO QUESTIONS	6-20

6

CURB AND GUTTER

INTRODUCTION

There are several types of concrete curb and gutter. Turn to Standard Index 300 in your plan book. Note that there are 2 types of gutter (valley and shoulder), 4 types of curb (A, B, D and drop) and 2 types of curb and gutter (E and F). In this chapter we will deal with Type F concrete curb and gutter, formerly known as Standard Curb and Gutter. To follow the Standard Index, you should know these basic parts.

- < the typical section of Type F curb and gutter in the upper left-center of the sheet
- < the three details in the lower right corner of the sheet
- < the general notes.

Look over these parts briefly, to become oriented -- then go on to the next page.

TERMINOLOGY

Let's start with some terminology. The diagram below names the parts of a standard curb and gutter.

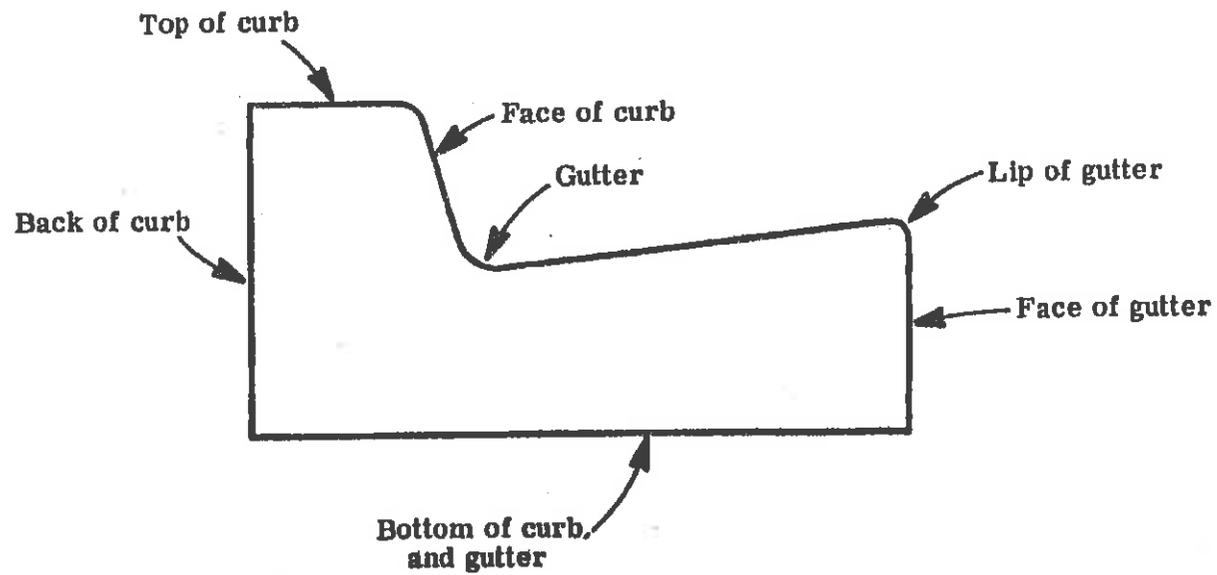

STAKING

Staking for curb and gutter is referenced to the back of the curb. Two kinds of stakes are driven:

1. hubs and tacks for horizontal alignment (line).
2. guard stakes and nails for vertical alignment (grade).

A typical staking situation is shown below.

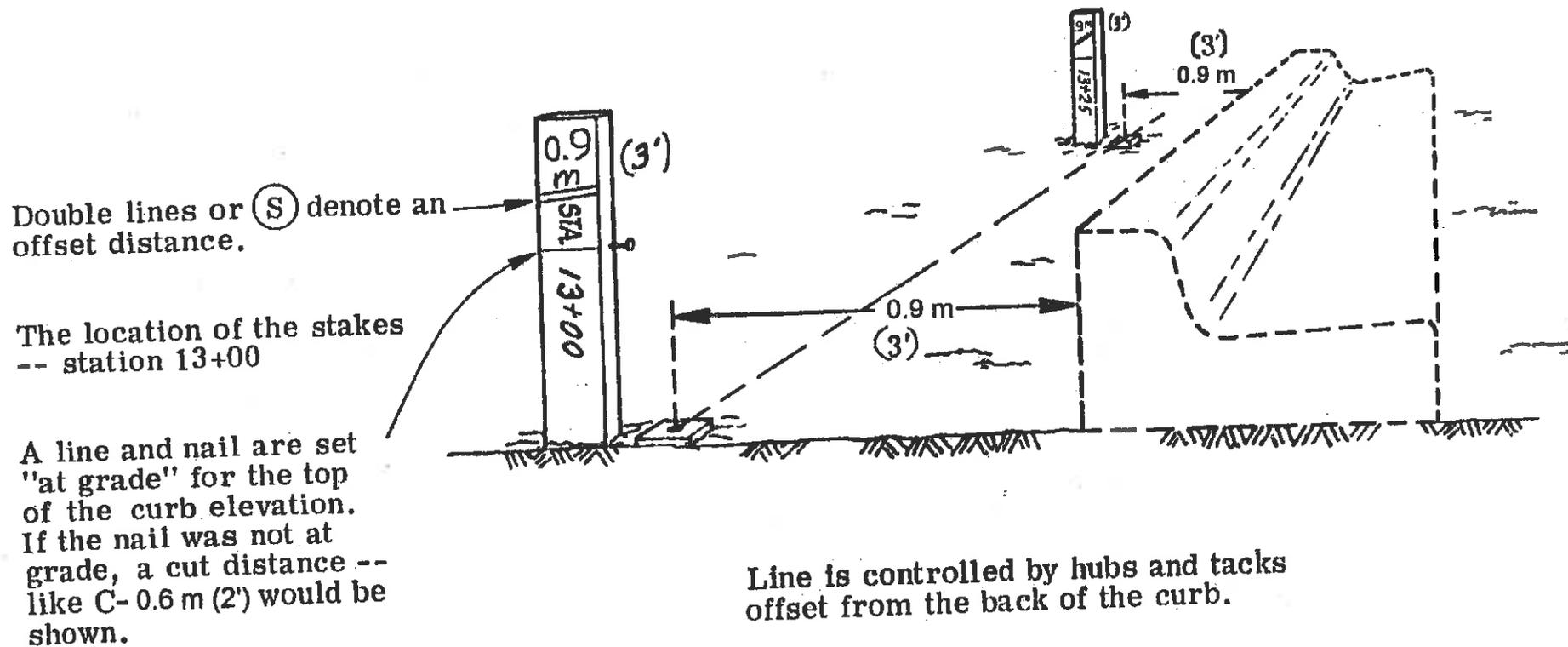

QUIZ

Refer to the Type F curb and gutter on Standard Index 300 for this quiz.

What is the height of the face of the curb? _____

What is the radius at the top of the curb? _____

What is the radius of the lip of the gutter? _____

The gutter is rounded to a _____ radius.

Use the stake and hub on the right to answer the questions below.

The curb is offset _____ meter (feet) from the tack in the

_____.

The top of the back of the curb is _____ the
nail in the _____.

These stakes are located at _____.

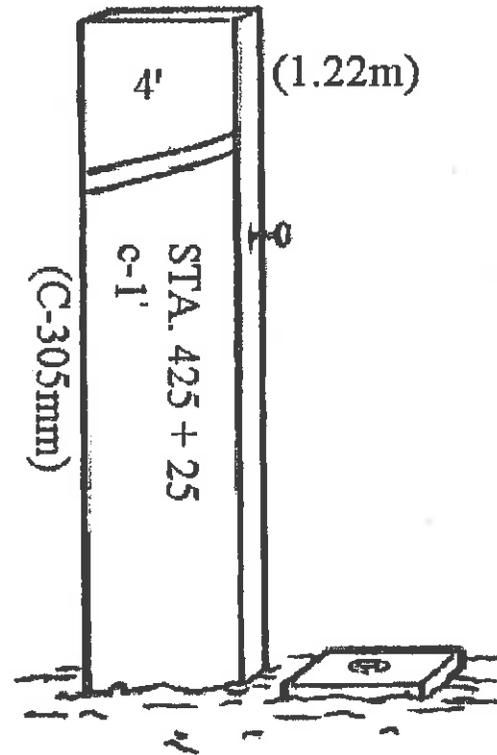

How did you do? If you need to, study now. The next few parts of this chapter are similar to the previous chapter. We will discuss excavation, forming and concreting. Start when you are ready.

EXCAVATION

Curb and gutter is constructed after the subgrade of the adjacent pavement is placed, stabilized and compacted. When determining the limits of the stabilized subgrade that extend beyond the back of the curb it is important to look at the typical section of the contract plans

The actual preparation of the subgrade may be accomplished by the use of an automatic finegrader. Finegraders are machines that operate from graded stringlines. They trim and fill the curb and gutter subgrade to the required elevation. Or the excavation may be done by hand.

Your inspection duties will be the same:

- ▶ Check the finished subgrade surface. It must be uniform -- free of holes or protruding rocks. Be sure the subgrade is wet before the concrete is placed.
- ▶ Check the grade. Use the stakes, a level or stringline, and a ruler.
- ▶ Check the depth, width and offset, to be sure that the curb and gutter will be in the right place.

CONCRETE PLACEMENT

FORMS

Forms are set at the back of the curb, face of curb, and the lip of the gutter. As an Inspector, you will be concerned with the following:

- ▶ Forms can be wood or metal, but they must be in good condition -- straight, without holes or protrusions and free of warps and bends.
- ▶ Forms must be strong enough, when staked, to hold the concrete at the proper line and grade.
- ▶ Where curb and gutter is constructed on a radius -- around a corner -- flexible forms that bend to fit the needed curvature must be used.
- ▶ All forms must have depths equal to the plan dimensions of the curb and gutter being constructed.
- ▶ "Eyeball" the form line as a double check for alignment.

Usually, curb and gutter will be formed in the manner shown below:

1. Pins and a string-line are set along back of the curb line. Forms are set against the string-line.

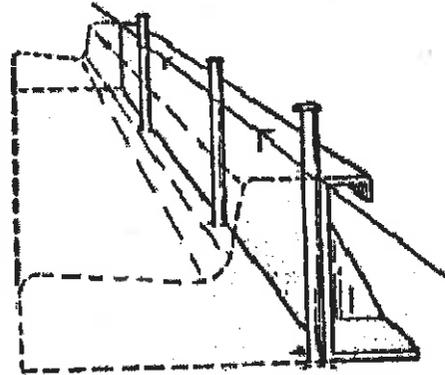

2. A "curb jack" and level are used to set the forms for the face of gutter.

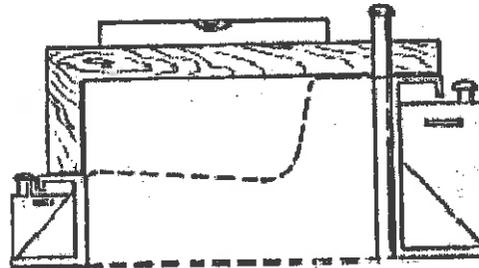

3. Curb face templets are set, supported by curb and gutter forms.

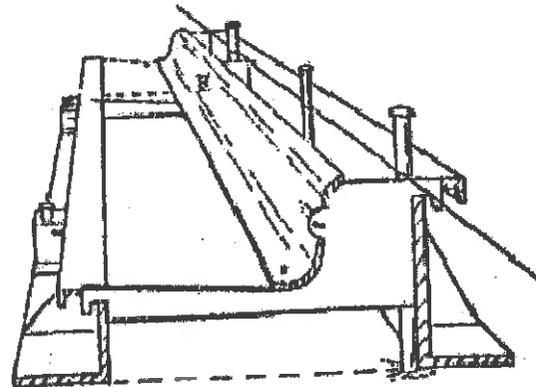

Forms must be clean, straight and oiled.

Check line and grade from the offset stakes -- not the pins and stringline.

Check curb jack accuracy-- or

Check line and grade of forms from stakes.

Check dimension of form-- at top of curb and gutter form.

Check contour of templet -- must be same as plans.

Check templet support -- may be needed every 5 feet (1.5 m)

Be sure pins and string-line are removed before concrete is placed.

SLIP FORM

Construction of a curb and gutter by machine methods may be permitted by the Engineer. It has become a common method. Concrete is placed by a piece of equipment called a slip form paver. No forms are set in place, only a stringline for grade.

The concrete is placed in the bucket of the slip form paver and is extruded in the shape of curb and gutter by use of a templet within the machine.

Before any concrete is placed, check the slip form for

- ▶ dimensions;
- ▶ the condition of the equipment;
- ▶ shape of the templet; and
- ▶ concrete, low or no slump.

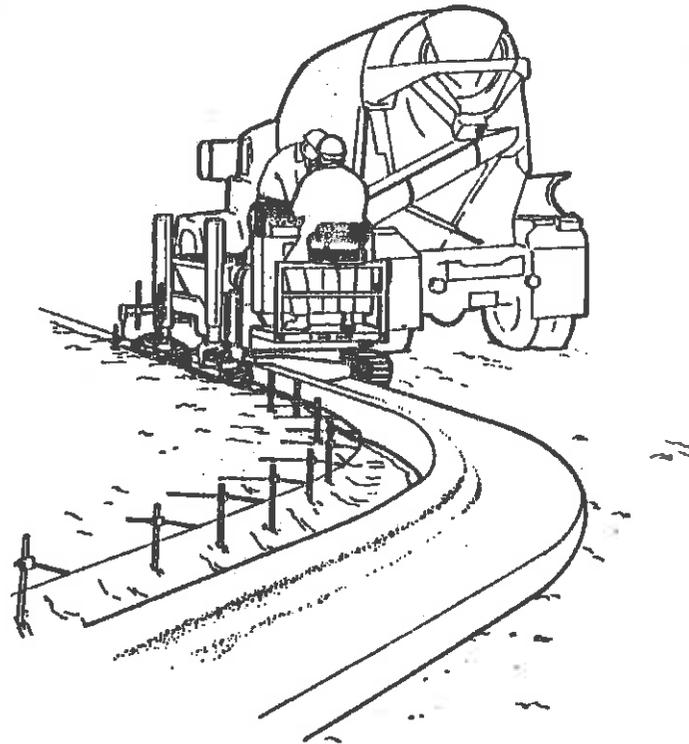

QUIZ

Curb and gutter adjacent to pavements is constructed on _____.

What four things must you check when the preparation of the subgrade is complete? _____

Curb and gutter forms must have depths equal to _____.

Besides dimensions, for what other two things must you inspect the forms? _____

As curb forms are being placed, what must you check?

1. _____
2. _____

QUIZ, continued

As the curb face templet is being placed in curb and gutter forms, what must you check?

1. _____
2. _____

If the Contractor plans to use a slip form machine to place curb and gutter, what three things must you check?

O.K. How many checks did you remember? There are a lot of them, but they are similar. If you need to, reread pages 6-6 through 6-9, then go on to PLACING CONCRETE.

PLACING CONCRETE

The actual placement of concrete -- in the forms or in the slip form paver -- is a fairly simple operation. But you do have some important inspections. Here's a good checklist:

- ▶ Is the subgrade wet? A dry subgrade will absorb moisture from the concrete.
- ▶ Is the subgrade graded and clean? Give it a final check before concrete is placed.
- ▶ Are the forms and templets straight and secure? Loose forms must be braced, and line and grade checked.
- ▶ Is the concrete workable? Is the slump within the desired range?
- ▶ Is the concrete placed and consolidated well? The concrete should be put into every corner and must be tamped and spaded until the surface is entirely covered with mortar (cement and water).
- ▶ Check the grade line. Are the dimensions and shape of the curb and gutter of the slip form correct? Check curb extruded from the paver and let the Contractor know about any problems.
- ▶ Have the tops been floated smooth and the edges rounded? Check the plans for the proper radii and make up templets to help you check quickly.

CONTRACTION JOINTS

Transverse contraction and expansion joints must be constructed in curb and gutter. Contraction joints must be placed every 10 feet (3 m), except where a lesser interval is required for closure (the end of a section). When curb and gutter is constructed adjacent to and abutting concrete pavement, the joints in the curb and gutter must be positioned to match the joints in the concrete pavement.

Contraction joints may be formed three ways:

1. Dummy joints (grooves placed at the desired contraction joint location) may be formed into the plastic concrete.
2. Dummy joints may be sawed into the hardened concrete.
3. Metal templets may be placed between the forms prior to concrete placement. Templets must have the right dimensions and be set perpendicular to the forms.

When forms are used, templets are the most common method of making contraction joints. Just be sure that the templets are secure, square to the forms and graded properly. The tops of the templets should be level with each other. The templets are removed when the concrete has set, but before the forms are removed.

When slip forms are used, sawing is the method required for making contraction joints. Be sure that the concrete has hardened enough for sawing. Check the spacing of the joints.

EXPANSION JOINTS

Transverse expansion joints are constructed at all inlets and radius points (where straight curbs begin to curve), at locations shown on the plans, and every 500 feet (150 m) on straight runs. Expansion joints are 2-inch (13 mm) in width and are filled with an approved expansion joint filler, which may be a hot joint sealer.

Longitudinal expansion joints are required between concrete pavement and gutters. Look at the Standard Index 300 for details. Note the requirements for the joint filler and the joint sealer.

QUIZ

Do you remember the checklist to inspecting concrete placement? Try to match the inspection conditions on the right with the part of the work on the left. More than one inspection condition may apply to each part.

1. ___ Subgrade
2. ___ Forms
3. ___ Concrete
4. ___ Finished curb and gutter

- A Spaded
- B Wet
- C Floated tops, rounded edges
- D Straight and secure
- E Graded
- F Shape

QUIZ, continued

A section of curb and gutter adjacent to asphalt pavement will be 38 feet (12 m) long. How many contraction joints will be constructed? _____

If the above section were adjacent to concrete pavement, what would be the requirements for spacing the joints? _____

What determines the time of sawing joints? _____

If dummy joints are not used, _____ are placed between the forms. You must check these for dimensions, stability, grade and _____.

Refer to your Standard Index. Expansion joints are used between gutters and _____ pavement. The joint is _____ inch (_____ mm) wide.

FINISHING

Finishing is an important part of this work, since curb and gutter is a highly visible structure -- to motorists and pedestrians. A good job can be ruined by a poor finish. Basically, two steps must be followed by the finishers: (1) give all exposed surfaces a final finish while the concrete is still green and (2) correct all defects.

1. Final Finish

Only a brush finish is required on curb and gutter. However, before the finishers begin, you should be sure that the gutter is checked with a 10 - foot (3.048 straightedge) straightedge -- either by the Contractor or you. This check will ensure that no bumps or depressions exist. The straightedge is laid parallel to the centerline of the roadway along the lip of the gutter. Any irregularities in excess of 1/4 inch (5 mm) must be corrected immediately.

2. Correct Defects

Curb and gutter forms must be removed within 24 hours after concrete placement, and all honeycomb areas must be filled with mortar.

Where required by the Project Engineer, the curb may need to be rubbed to a smooth surface with a soft brick or wood block -- sometimes using a thin grout or mortar.

CURING

Curing is begun as soon as the concrete finishing is completed and must be continued for 72 hours. There are three approved methods of curing in the Standard Specifications:

- ▶ wet burlap method,+
- ▶ membrane curing compound method, and
- ▶ polyethylene sheeting method.

The most common is the membrane curing compound method. The basic requirements are these:

- ▶ The compound must be applied by a sprayer at a rate of one gallon per 200 square feet (0.2 L/ m²).
- ▶ The coverage must be a uniform single-coat continuous film.
- ▶ The compound must be agitated prior to use, and during use, to minimize any settlement. The spray should be white, so if the color changes, shake it up.

Your most important check will be to ensure that the compound is not blotched or streaked on the concrete. The concrete must be cured for 72 hours. After the forms have been removed, the exposed concrete must be banked with moist soil or cured by one of the other methods for the remainder of the 72-hour period.

BACKFILLING

The backfilling requirements for curb and gutter are few:

- ▶ After forms have been removed, but no later than three days after the concrete was placed, the front and back of the curb and gutter will be backfilled using suitable material.
- ▶ Backfill must be compacted in layers not thicker than 6 inches (150 mm).

MEASUREMENT

The pay quantity for curb and gutter is determined from plan dimensions -- station to station -- unless changes were made that increased or decreased the quantity of curb and gutter or unless errors were found in the plan quantities. When either or both of these conditions exist, the final pay quantity is determined by actual field measurements taken along the gutter line.

QUIZ

What are the two steps in finishing concrete?

1. _____
2. _____

Any irregularities in excess of _____ must be corrected immediately.

If curing begins at 5:00 pm on Tuesday, until what day and hour must it continue? _____

During the application of a membrane curing compound, at one gallon/200sq. ft., (0.2 L/m²) the compound changes color. What should be done by the Contractor?

- A. Increase application rate to 1 gal./150 sq. ft. (0.2 L/m²)
- B. Begin double coating.
- C. Shake up and remix the curing compound.

An error is detected in the plan quantity for curb and gutter on a certain job. How should the final pay quantity be determined? _____

O.K. When you are ready, go on to Chapter Seven, TRAFFIC SEPARATOR, which is very similar to curb and gutter.

ANSWERS TO QUESTIONS

Page 6-5

- ▶ : inch (20 mm)
- ▶ 6 inches (150 mm)
- ▶ 2 inch (50 mm)
- ▶ 3 inches (75 mm)
- ▶ 4 feet (1.22 m); hub
- ▶ 1 foot (305 mm) below; stake
- ▶ Sta. 425 + 25

Page 6-10

- ▶ Stabilized subgrade
- ▶ surface, line, grade, damp condition
- ▶ plan dimensions
- ▶ condition; strength
- ▶
 1. Line and grade
 2. Formed dimensions

Page 6-11

- ▶
 1. Contour of templet
 2. Supports
- ▶ Dimensions; condition of slip form paver; shape of templet

Page 6-14

- ▶
 1. B,E
 2. D,E,F
 3. A
 4. C,F

Page 6-15

- ▶ 3
- ▶ must coincide with pavement joints
- ▶ hardness of concrete
- ▶ templet; squareness
- ▶ concrete; 2 inch (13 mm)

Page 6-19

- ▶
 1. final finish
 2. correct defects
- ▶ 1/4 inch (6 mm)
- ▶ Friday 5:00 p.m.
- ▶ C
- ▶ by field measurements

CHAPTER SEVEN

Traffic Separator

CONTENTS

STANDARD INDEX	7-2
CONSTRUCTION OPERATION	7-3
Types I and VI	7-3
Types XI and V	7-4
STAKING	7-4
ANSWERS TO QUESTIONS	7-6

TRAFFIC SEPARATOR

The requirements and inspection duties for traffic separator are exactly the same as those for curb and gutter. However, the construction procedure is slightly different. In this chapter we will review the Standard Index, the construction operation and the method of staking used for traffic separator.

STANDARD INDEX

Find the Standard Index for traffic separator - 302. Note that there are four types. Types I and IV are used when the adjacent pavement is flexible. Types II and V are used when the adjacent pavement is portland cement concrete. Types I and IV have Option I and Option II. The Contractor may choose which Option to construct as long as a certain one is not specified.

CONSTRUCTION OPERATION

TYPES I AND IV

Under Option 1, the construction of Types I and IV traffic separator may be poured in one or two separate operations at the discretion of the Contractor.

1. Construct the outside sections - the curb - first. By doing this the forms can be used to guide a "go—devil"-- a contoured float that will shape the curb properly.
2. Construct the inside section, using the two outside sections as concrete "forms". Construction joints will be formed between the three parts. Be sure that the finishers get the proper slope in the mid-section.

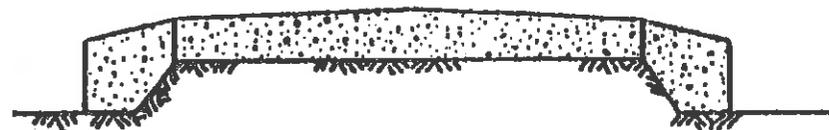
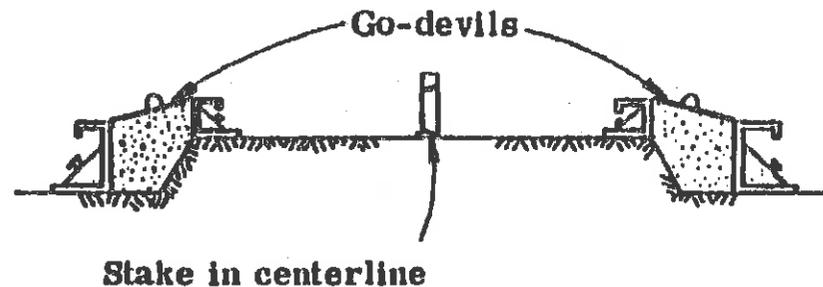

For Types I and IV, Option II, the construction is in one step.

TYPES II AND V

For types II and V traffic separator, the construction operation is done in one step. No construction joints are used. So the inspection is just the same as for curb and gutter B only the shape changes.

STAKING

As you may have determined, stakes are needed only for the curb sections of Types I and IV traffic separator. Since Types II and V are Poured adjacent to portland cement concrete pavement, the staking would not be necessary.

QUIZ

Refer to the details of Types I Concrete Traffic Separator in Standard Index to answer the questions below.

What must be done to the subgrade under the traffic separator? _____

How many construction joints are permitted? _____

How wide must the curb be? _____

Fill in the correct dimensions for a Type I Separator 6 feet (1.8m) wide, in the diagram below:

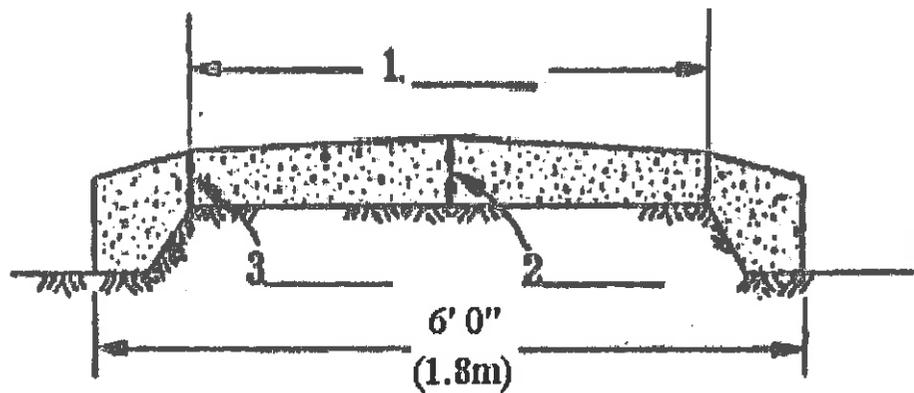

ANSWERS TO QUESTIONS

Page 7-5

- ▶ stabilized
- ▶ two
- ▶ 9 inches (225 mm)
- ▶ 4'-6" (1.35m)
- ▶ 52" (140 mm)
- ▶ 5" (125mm)

CHAPTER EIGHT

Concrete Sidewalk

CONTENTS

PLANS	8-2
STAKING	8-3
SUBGRADE PREPARATION	8-3
CONCRETE PLACEMENT	8-5
Forms	8-5
Steel Reinforcement	8-5
Concrete	8-5
Joints	8-6
Finishing	8-8
Curing	8-8
ANSWERS TO QUESTIONS	8-11

8

CONCRETE SIDEWALK

Concrete sidewalk is constructed just like the other structures we have covered -- subgrade preparation, forming, concreting, joints, finishing and curing all must be done. In this chapter we will skip those things covered in the previous chapters and cover the key inspection points you must know for sidewalk.

PLANS

First, check your plans. Three things are important:

- ▶ the cross slope of the sidewalk,
- ▶ the dimensions, and
- ▶ thickness of the concrete.

Be familiar with these facts -- they will be useful during your inspection.

STAKING

Two situations exist: (1) where the sidewalk is adjacent to and abuts a curb and (2) where the sidewalk is separated from the curb.

In the first case no stakes are needed. Be sure that the Contractor maintains the line and grade of the existing curb.

In the second case, offset stakes are set and a stringline pulled along one edge of the planned sidewalk. You can check this line by eye, and the grade can be checked from the stakes.

SUBGRADE PREPARATION

The subgrade must be flat and firm. Concrete sidewalk generally has no steel reinforcement, so the concrete depth is critical. If a rock or rise in a subgrade is present the concrete will be placed thinner than required, creating a weakened plane, which will crack when the concrete hardens. Before concrete is placed, the subgrade must be wetted thoroughly.

QUIZ

Before any sidewalk construction begins, you should check your plans for the _____, _____, and _____.

Name the line and grade controls for the two situations below.

Sidewalk adjacent to curb: _____
Sidewalk separate from curb: _____

In order to ensure proper concrete depth, the _____ must be inspected for high spots and protruding rocks.

Before concrete is placed on the subgrade, the subgrade must be thoroughly _____.

CONCRETE PLACEMENT

FORMS

Check forms for all the things we have mentioned before: strength, dimensions, uniformity and cleanliness. And, be sure that the forms are oiled prior to concrete placement.

STEEL REINFORCEMENT

If the plans call for it, steel reinforcement will be placed in the sidewalk. Check the sizes, dimensions and condition of the steel before it is placed. When it is placed check the spacings, ties and depths.

CONCRETE

Check the concrete to be sure that it is:

- ▶ thick enough. It will be either a 4 - inch (100-mm) 6- inch (150-mm) sidewalk.
- ▶ spaded well. All corners must be consolidated.
- ▶ uniformly placed. The appearance is important.

JOINTS

One of your inspection duties will be to check the placement of expansion and contraction joints.

Contraction Joints

Contraction joints may be the open type or sawed. Open-type joints are formed by $\frac{1}{2}$ -inch (13-mm) dividers staked in place. After concrete is placed and sets, the dividers are removed, leaving an open joint. During concrete placement, inspect the dividers to be sure that they remain straight and secure. The finishers will then edge the slot with a 2 - inch (13-mm) radius finishing tool, like the one on the right.

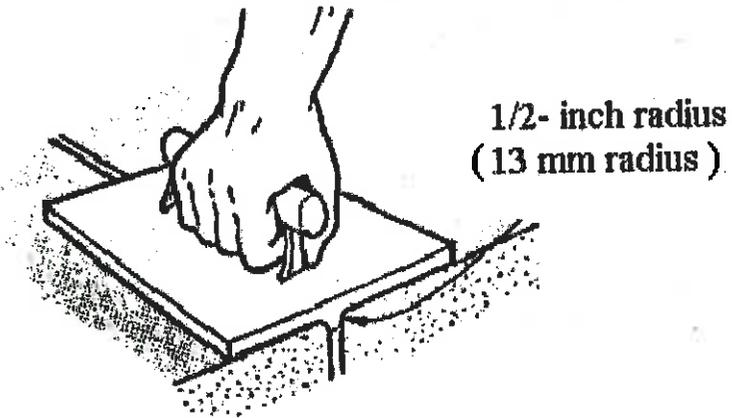

Sawed joints are cut with a concrete saw after the concrete has set. In sawing the contraction joints, the saw does not penetrate the full depth of the slab. The saw cuts a slot $\frac{3}{16}$ inch (5 mm) wide and at least 1-1/2 inches (40 mm) deep. Be sure to check the spacing of joints being cut. The timing is also important. Use these guidelines:

- ▶ within 12 hours after finishing -- cut joints at 30-foot (9-m) intervals.
- ▶ within 96 hours after finishing -- cut remaining joints.

Expansion Joints

Expansion joints are used between sidewalk and adjacent curb or at driveways. The joints are formed by using 2 - inch (13 - mm) preformed joint filler positioned before the concrete is placed.

The diagram below shows the joint filler in place. Note that the hot-poured joint sealer is not required.

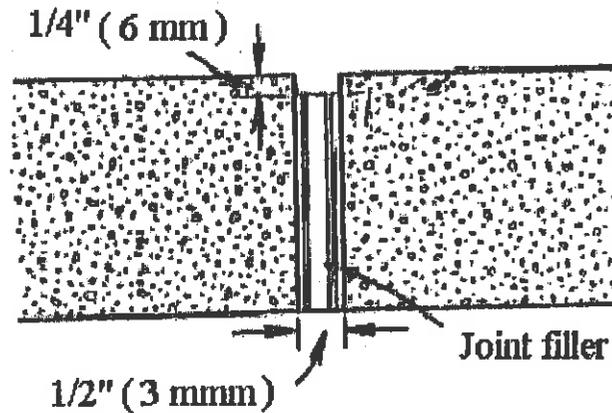

It may also be necessary to place filler material around any objects that are in the sidewalk, such as utility boxes, meters and poles. So be sure that these get the same treatment that the other expansion joints get.

What should you check?

1. The joint filler must meet the specifications.
2. The joint filler must be placed properly.
3. The top of the joint should be cleaned after concrete placement so that the joint is not closed.

FINISHING

The final finishing of a sidewalk involves three steps -- screeding, brooming, and edging. Here's what you must look for:

1. A wood or metal screed may be used, but it must be used perpendicular to the forms to obtain the desired grade and cross slope, and it must remove surplus water and laitance (the milky cement-water mixture on the surface.)
2. To check for surface irregularities, lay a 10-foot (3.048 m) straightedge on the concrete. The surface must not vary by more than 1/4 inch (6 mm) longitudinally and 1/8 inch (3 mm) on a 5-foot (1.5-m) transverse section. Then, the broom finish is applied transversely to the entire surface.
3. The edges of the sidewalk -- like the joints -- get rounded with an edging tool that has a radius of 2 inch (13 mm).

CURING

Curing must begin after finishing, and follow the same requirements as for curb and gutter. Most Contractors will use white pigmented curing compound applied by a pressure sprayer.

QUIZ

Complete the labels and dimensions in the diagram of an expansion joint below:

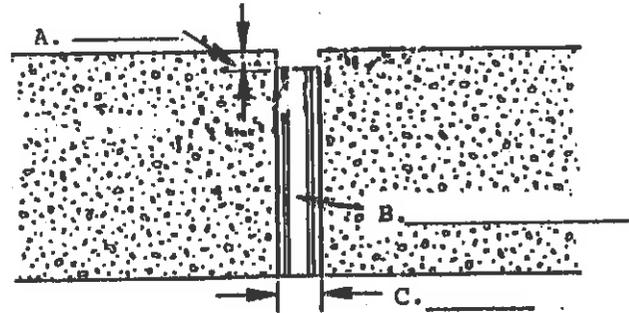

Sidewalk surfaces checked with a 10-foot (3.048m) straightedge must not vary by more than _____ longitudinally and _____ on a 5-foot (1.5 m) transverse section.

The Contractor begins sawing contraction joints but the concrete begins raveling and spalling. What should you do and why? _____

What should be the dimensions of the saw cut? _____

If joints are cut 10 hours after finishing, what is the spacing between them? _____

When must the remaining joints be cut after the first joints? _____

QUIZ, continued

Expansion joint material is placed between sidewalks and adjacent curb or driveway. You also must be sure that it is placed around _____.

Expansion joint filler is placed to within _____ inch of the top of the joint.

What three steps must be followed during final finishing:

1. _____
2. _____
3. _____

What are the straightedging requirements? _____ and _____.

That's all for concrete sidewalk. The last two chapters cover ditch and slope pavement. Now would be a good time to review the first eight chapters. Then begin Chapter Nine, DITCH PAVEMENT.

ANSWERS TO QUESTIONS

Page 8-4

- ▶ cross slope; dimensions; thickness of concrete
- ▶ existing curb; offset stakes
- ▶ subgrade
- ▶ wetted

Page 8-9

- ▶ A. 1/4 inch (6 mm)
- ▶ B. Filler Material
- ▶ C. 2 inch (13 mm)

- ▶ 1/4 inch (6 mm); 1/8 inch (3 mm)
- ▶ Stop sawing -- concrete is not hard enough
- ▶ 3/16" (5 mm) wide and 1-1/2" (40 mm) deep
- ▶ 30 feet (9 m)
- ▶ within 96 hours

Page 8-10

- ▶ Objects in the sidewalk
- ▶ 1/4 inch (6 mm)
- ▶ 1. Screeding
- ▶ 2. Brooming
- ▶ 3. Edging
- ▶ 3 inch (6mm) in 10 ft. (3.048m) longitudinally
- ▶ c inch (3 mm) in 5 ft. (1.5 m) transversely

CHAPTER NINE

Ditch Pavement

CONTENTS

PURPOSE	9-2
STANDARD INDEX	9-3
CONSTRUCTION	9-5
Staking	9-5
Subgrade	9-5
Forms	9-6
Concrete	9-6
Joints	9-6
Finishing	9-6
Curing	9-6
Weep Holes	9-8
MEASUREMENT	9-10
ANSWERS TO QUESTIONS	9-11

9

DITCH PAVEMENT

PURPOSE

Concrete ditch pavement is placed to prevent erosion, to carry water and to reduce future maintenance problems. While the location of ditch pavement is shown on the plans, you also should be aware of situations in the field, which may require ditch pavement. Usually, additional ditch pavement will be needed:

- ▶ where frequent erosion problems -- such as wash-outs -- occur.
- ▶ where the plan length of ditch pavement does not carry water far enough along the existing ditch.

In each case, you should inform your Project Engineer of the problems you encounter.

STANDARD INDEX

Most of the information you will need to inspect ditch pavements is contained in Standard Index 281. Turn to that sheet now and find the following important parts.

Two details of junctions of ditch pavement with lateral ditches

Two profiles -- one for junction with lateral ditches, one for everywhere else

Dimensions for the profile and typical section for each type of ditch pavement

An alternate plan for ditch pavement in special cases

The four most common ditch pavement typical sections

Details for transition section

Weep hole arrangement for ditch pavement

General notes

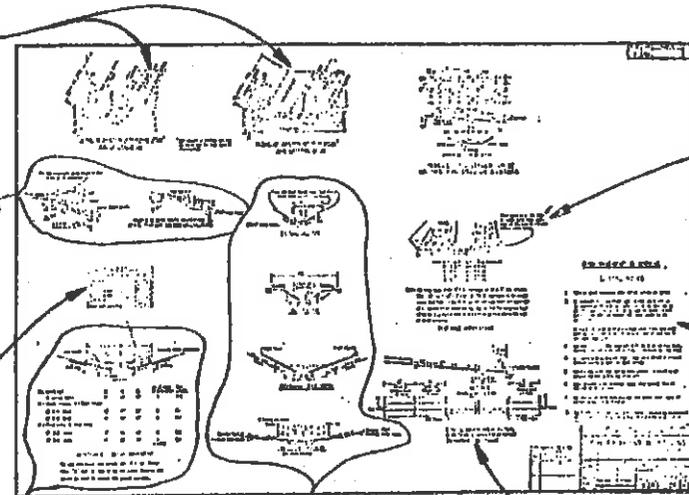

Look over the Standard Index, then try the quiz on the next page.

QUIZ

Use the Standard Index to answer the questions below.

What is the thickness of a typical section of concrete ditch pavement? _____

What is the thickness of concrete ditch pavement in a roadway side ditch? _____

What is the depth of the toe wall from the flow line of the ditch pavement? _____

Sodding is placed _____ feet (mm) on either side of the ditch pavement in medians.

Where is the specific type of ditch pavement to be used indicated? _____

What is the longitudinal spacing between weep holes? _____

CONSTRUCTION

Most of the construction of concrete ditch pavement is the same as for the other concrete structures we've discussed. So rather than go into repetitious detail, there are checklists on these two pages covering your inspection duties.

STAKING

Line
Grade
Offset

Stakes show
offset, cut to
flow line.

Hubs set
alignment
for stringline.

SUBGRADE

Slopes
Ditch Depth
Uniformity
Firmness
Grade
Toe wall
Wet before

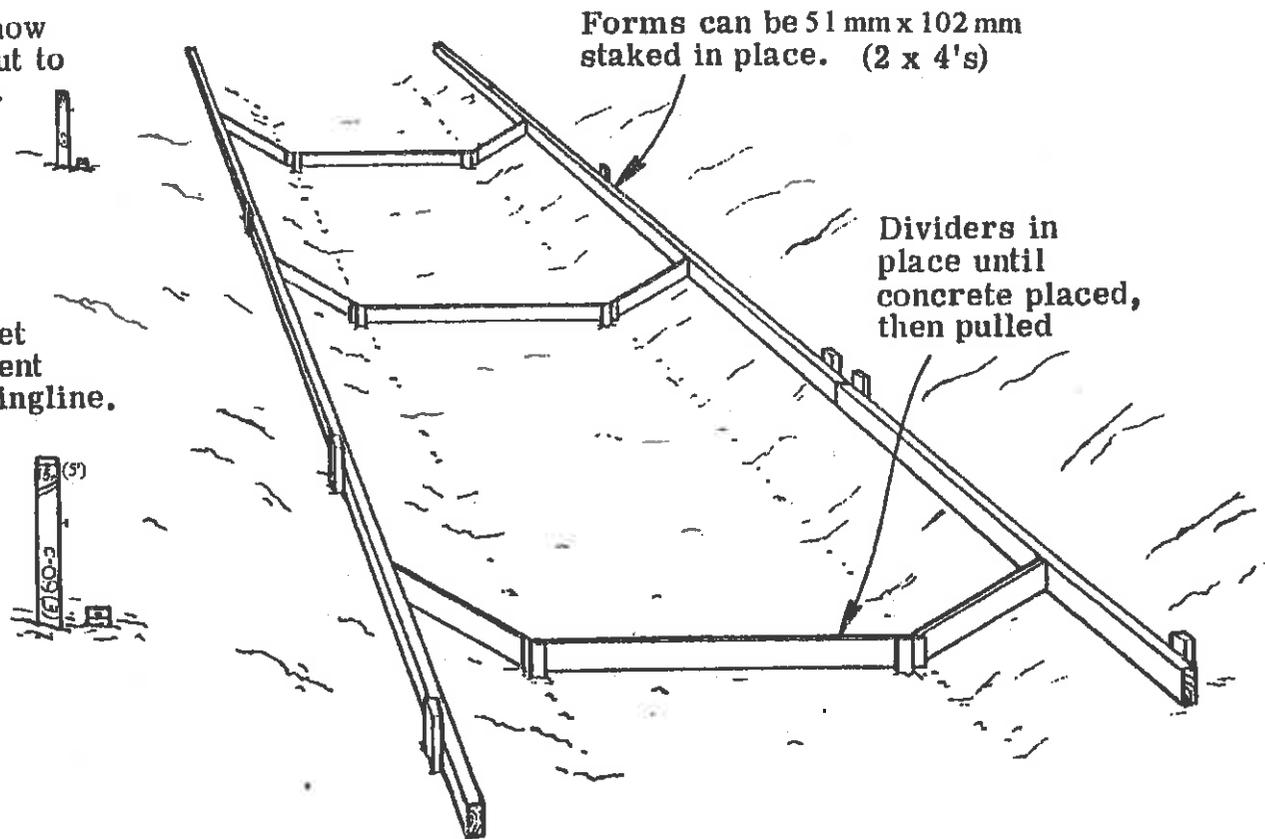

10

FORMS

Depth
Stability
Strength

CONCRETE

Place every other joint on long sections
Start placement at bottom of ditch
Check toe wall depth, thickness
Screed level with forms

JOINTS

Contraction joints every 25 feet (7.5 meters)
Expansion joints 2-inch (13 mm) at inlets, endwalls and intervals of not more than 200 feet (60 m)

FINISHING

Joints open, with 3- (6 mm) radius edges
Laitance removed

CURING

Same as curb and gutter

QUIZ

List the seven inspection points that are important for the subgrade.

1. _____
2. _____
3. _____
4. _____
5. _____
6. _____
7. _____

Contraction joints are spaced every _____ feet (meters), while expansion joints are spaced every _____ feet (meters) in long sections.

You can find information about joints and other construction points in the general notes of the Standard Index.

WEEP HOLES

Weep holes are placed in concrete ditch pavement in order to relieve pressures created by water in the ground behind or under the concrete. The Standard Index shows the arrangement of weep holes and the requirements for their construction. Generally, the construction sequence goes like this:

1. Gravel or crushed stone 2 cu. ft. -- 12" H12" H6" (0.014 m³ -- 300 mm x 300 mm x 150 mm) is placed in the subgrade. This is covered by 1 sq. ft. (0.10 m²) piece of galvanized wire mesh 3 - inch (6 mm) openings.
2. Location of weep holes are indicated by nails or marks on to form, so a stringline can be pulled across the pavement later to find the weep hole.
3. Concrete is placed.
4. Finishers find the weep hole locations, dig out concrete and place forms (tin cans can work) for weep holes.
5. When concrete is set sufficiently, forms are removed.

Most importantly, you must be sure that the correct number of weep holes are placed in the right places. Consult the Standard Index for details of the arrangement and placement of weep holes.

QUIZ

Use the Standard Index to help you with this quiz.

Why are weep holes placed in ditch pavement? _____

What is placed in the base at weep hole locations? _____

Once the concrete is placed and the subgrade covered -- how can you locate weep holes? _____

What is the maximum longitudinal spacing between weep holes? _____

If the width of the bottom of the ditch pavement were 6 ft (1.8 m), how many rows of weep holes would be required? _____

MEASUREMENT

Concrete ditch pavement is paid for by the square yard (meter). This is computed by using field measurements you or the survey crew will take. For toe walls you will have to calculate the volume of concrete, then convert this to equivalent square yards (meters), using the plan thickness of the ditch pavement.

Your calculations will not include deductions for weep holes, inlets, manholes, other drainage structures or utilities in the pavement area.

QUIZ

What is the unit of measure by which ditch pavement is paid for? _____

A section of concrete ditch pavement has the following dimensions:

Bottom width:	8 feet (2.5 m)
Side width:	4 feet (1.2 m)
Plan length:	100 feet (30.5 m)
Other dimensions according to standard drawing.	

What is the pay quantity? _____

Hint: After calculating the equivalent area in the toe walls, the remaining length of ditch pavement is 99 ft. (30.2 m)

O.K. Check over this chapter again, then go on to SLOPE PAVEMENT.

ANSWERS TO QUESTIONS

Page 9-4

- ▶ 3 inches (75 mm)
- ▶ 3 inches (75 mm)
- ▶ 24 inches (600 mm)
- ▶ 2 feet (600 mm)
- ▶ Plans
- ▶ 10 feet (3 m) C to C

Page 9-9

- ▶ To relieve water pressure under concrete
- ▶ 2 cu ft (0.014 m³) #6 aggregate and wire mesh
- ▶ Marks or nails on side form
- ▶ 10 feet (3m) C to C
- ▶ Two

Page 9-7

- ▶ 1. Slopes
- ▶ 2. Ditch depth
- ▶ 3. Uniformity
- ▶ 4. Firmness
- ▶ 5. Wet before concrete placement
- ▶ 6. Toe wall depths
- ▶ 7. Grade
- ▶ 25 feet (7.5 m); 200 feet (60 m)

Page 9-10

- ▶ Square yard (meters)
- ▶ 190.2 sq. yd. (159.0 m²)

CHAPTER TEN

Slope Pavement

CONTENTS

INTRODUCTION	10-2
PLANS	10-3
LAYOUT AND STAKING	10-6
Layout	10-6
Staking	10-9
Inspection	10-9
CONSTRUCTION	10-11
Sequence	10-11
Toe Wall and Berm	10-12
Forms	10-13
Embankment	10-15
Weep Holes	10-15
Joints	10-16
Concrete Placement	10-16
DOCUMENTATION	10-21
ANSWERS TO QUESTIONS	10-24

10

SLOPE PAVEMENT

INTRODUCTION

Slope pavement is placed around embankments at bridge abutments for three reasons:

- ▶ It prevents erosion, which eliminates maintenance problems in hard to maintain areas.
- ▶ It provides pleasing, uniform appearances.
- ▶ It protects areas where vegetation will not grow.

The construction and inspection are much the same as for the other concrete structure we have discussed. However, slope paving usually is a larger, more complicated operation, because of the size of the area covered and the steepness of the slopes. So in this chapter we will cover all phases, with special emphasis on the most critical aspects of the work. Also, at the end of this chapter is a section on documentation, for all the work discussed in this text.

PLANS

Much of the information you will need will be found in the details in the plans. A typical detail for Fin. Project No. 000000-00000. Turn now to page A-10.

Here are the important parts:

- ▶ The lower middle portion of the sheet shows a section through the forward slope with details of the weep holes. It also shows a section through the toe wall.

- ▶ To the right of the forward slope section is the drain details. Note the positioning of the filter fabric.

- ▶ In lower left hand corner is the section through the end wall showing the slope of the end wall and the expansion joint.

- ▶ Detail A above the section through the end wall shows the joint construction between the slope pavement and the end bent, end walls, toe walls and on both edges of the berm.

- ▶ For scoring the slope pavement, look for details in the note - lower left hand corner.

This diagram shows the important parts of the slope pavement in the plans.

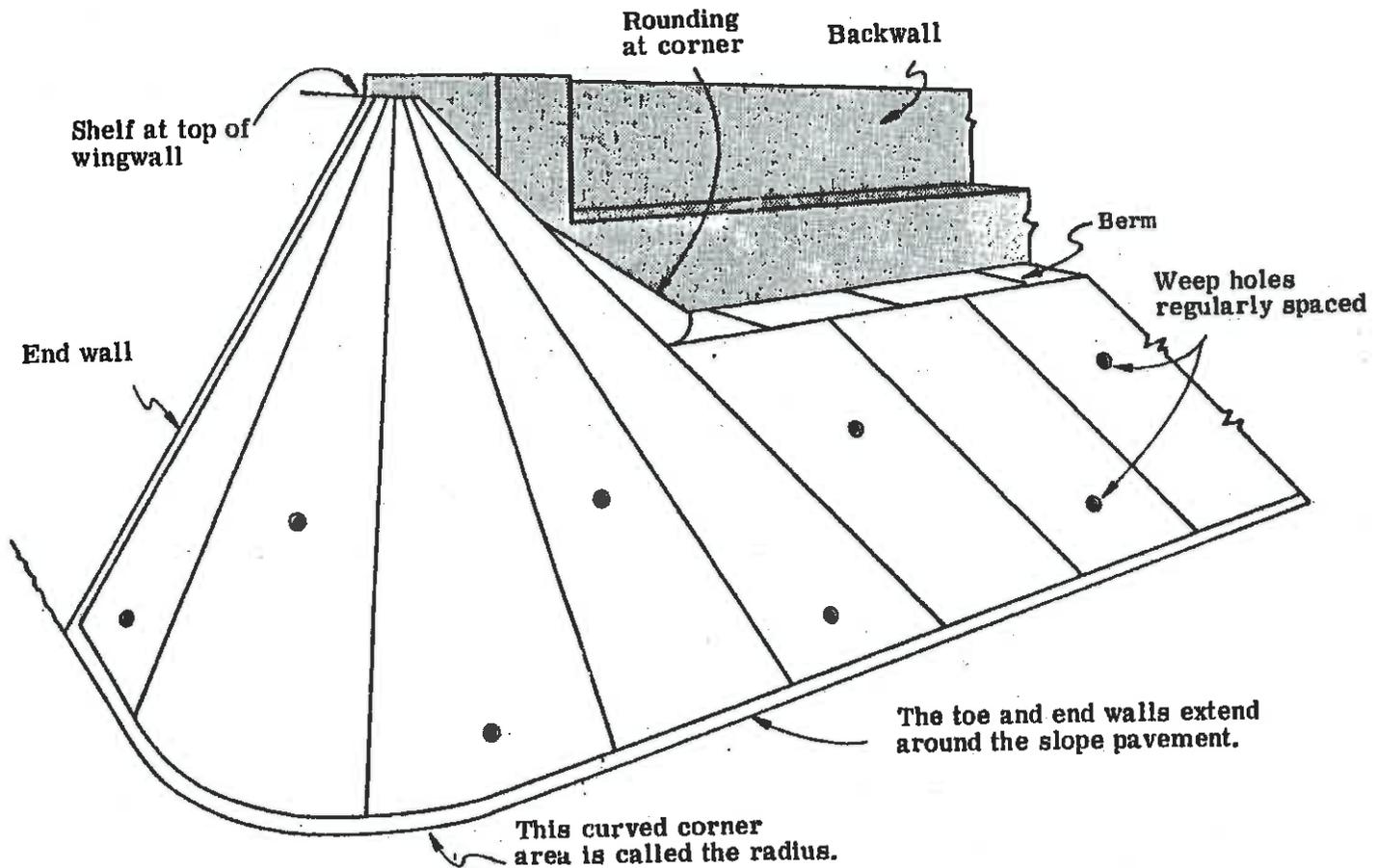

QUIZ

Refer to sheet No. A-10 of Project 000000-00000 to answer the questions below.

What is the width of the berm? _____

What is the rate of fall for the slope pavement? _____

How thick is the slope pavement? _____

What is the width of the toe wall? _____

If the slope pavement length (berm to toe wall) is 30 feet (9 m), what will be the spacing between the rows of weep holes? _____

For the last one, look at the section through forward slope. "L/3" and "L" is the length from berm to toe wall. O.K.?

Now go on to the next section.

LAYOUT AND STAKING

LAYOUT

One of the most critical phases in the construction of slope pavement is the layout. Basically the problem is this: you want to wrap a sheet of concrete around the abutment of the bridge. This may not sound too difficult -- and it's not really -- but there are a few qualifiers:

- ▶ The berm width (minimum 3 feet (0.9 m)) must be maintained.

- ▶ The line drawn between the top of the slope pavement at the shoulder of the road and the toe wall must pass below the top of the backwall.

- ▶ The slope of the slope pavement is specified to be 2:1. If a modification of the slope appears necessary, consult the Project Engineer.

This profile view should help to clarify some of the main points.

1. This point is stationary.

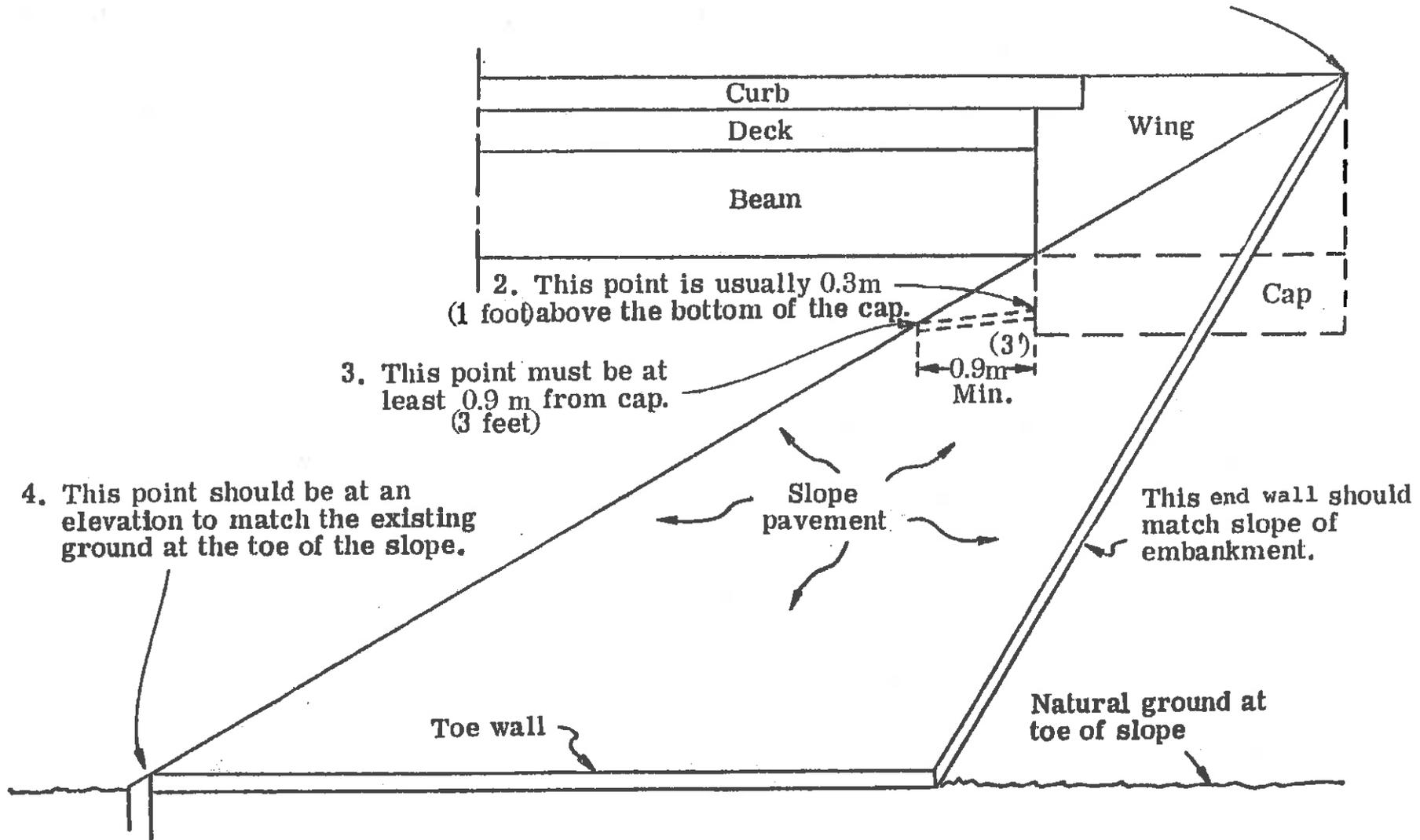

This plan view also will help. The points numbered correspond to the points on the previous page.

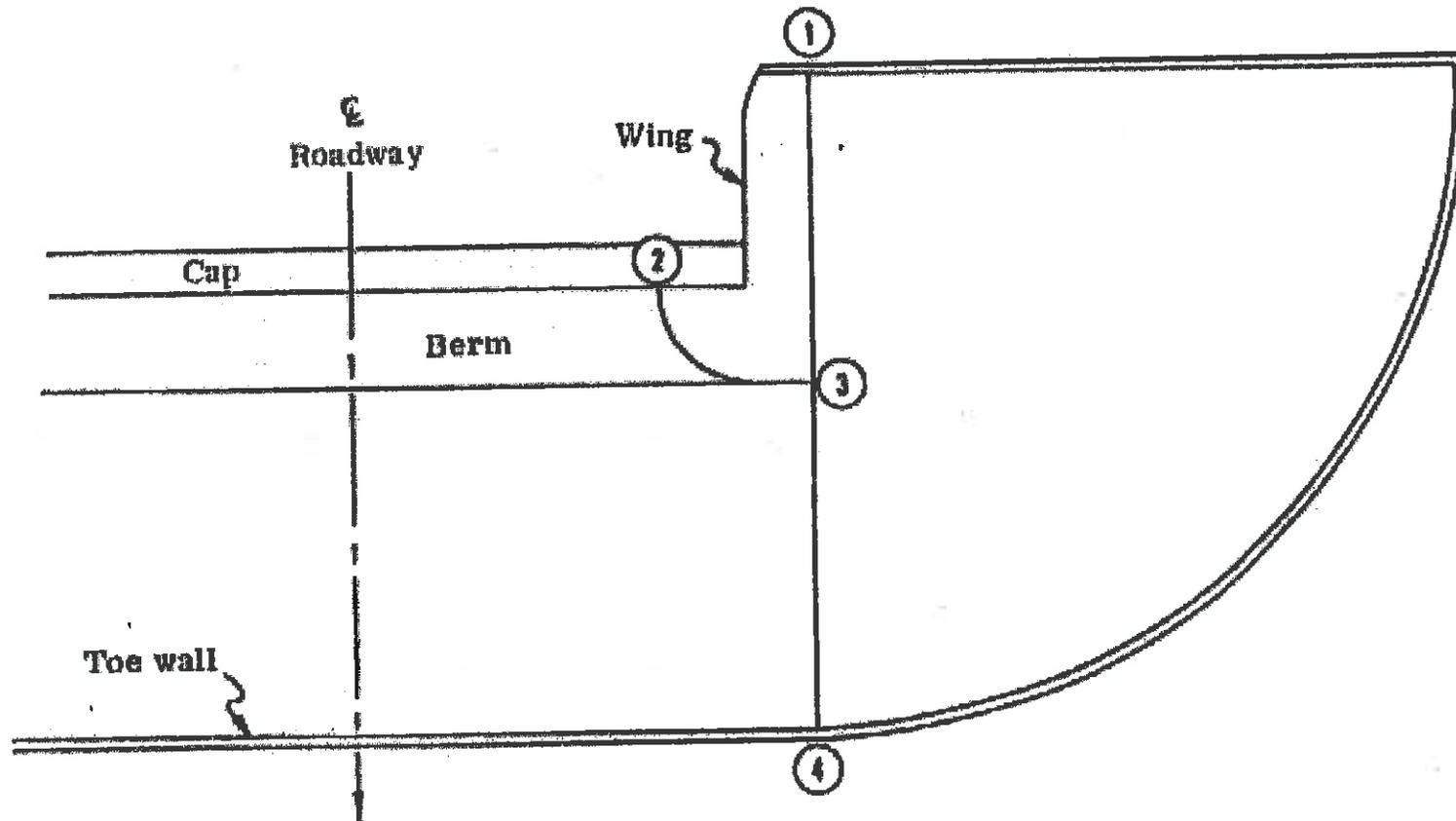

When staking slope pavement you will first establish points 1, 2, 3 and 4 on each side of the bridge. Stringlines should be pulled from point (1) through point (3) to point (4). From these lines you will determine if any adjustment at point (3) is needed. You then complete the staking under the bridge. Using point (1) as a radius point, you then stake the radius section.

STAKING

Once the layout is complete, it can be staked. Usually, stakes are needed only for the berm and the toe wall. Once these two parts are constructed, the rest of the slope pavement can be controlled from them.

The stakes themselves will be like others we have seen -- a hub and nail for alignment; a guard stake with the offset, cut or fill and a tack for grade. The amount of offset used in staking the toe wall will be determined by the Contractor to suit the existing conditions and the type of equipment he plans to use.

INSPECTION

What do you do in the field? Well, mainly you will watch and check the Contractor's methods. If you need to, call in a survey crew to double check the layout.

Also, check the accuracy of the stakes. Are they offset properly, so they will not be knocked out during work? Will the berm be set at the right place, so the slope pavement will not change slopes?

"Eyeball" the proposed slope pavement. In the field, the Contractor probably will use a stringline to measure around the radius. The curve should be smooth -- and the slope must not exceed the maximum allowable rate. Run your own stringline from the top of the slope pavement to a point on the toe wall directly below. The slope should remain constant.

Finally, check the berm slope. It should slope away from the end bent at the minimum rate of 1 inch per foot (25mm per 300mm).

QUIZ

For slope pavement to fit a bridge, it must be placed so that the minimum _____ width is maintained and the maximum _____ is not exceeded.

The one stationary control point is at the _____.

The berm slope should slope away from the end bent at the minimum rate of _____.

How can you check the slope of slope pavement on the radius? _____

Go on to CONSTRUCTION.

CONSTRUCTION

SEQUENCE

The construction sequence for slope pavement should go like this:

1. The slope is graded to the general shape and slope needed. Check to be sure the required density of the embankment is obtained.
2. The toe wall and berm are placed. Alignment and grade are controlled by offset stakes.
3. The forms for the slope pavement directly under the bridge are placed. The slope pavement is placed in "ribbons" -- 4-foot (1200 mm) strips -- that are aligned and graded from the berm to the toe wall, usually with stringlines.
4. The embankments for alternating ribbons are smoothed and compacted to the proper depths.
5. Concrete is placed in the prepared forms -- every other ribbon -- and screeded to the forms.
6. The forms are removed when the concrete has hardened.
7. The remaining ribbons are placed -- embankment prepared, weep holes placed, concrete placed and screeded along existing ribbons.
8. The radii are formed and placed in similar fashion -- in alternating ribbons.

Now, let's look at your inspection duties at each step along the way.

TOE WALL AND BERM

The first parts of the slope pavement to be constructed are the toe wall and the berm, which then form the remaining slope pavement. Your inspection of these items will be concerned mainly with ensuring proper alignment and grade. If these sections are not aligned and graded properly, then the entire slope pavement will be affected.

But you will also have to check some other things. Look at the plan sheet and check the points below:

- ▶ The berm's dimensions will be important. Be sure it has a minimum 3-foot (915 mm) width, a 1- inch per foot (25 mm per 300 mm) slope and the proper 4-inch (100-mm) thickness.
- ▶ The toe wall slopes away from the pavement. Again, check the dimensions.
- ▶ The embankment under the berm and slope pavement must be firm and well compacted.
- ▶ The concrete should be placed in all corners and well consolidated.

FORMS

After the toewall and berm are in place, the Contractor can set up forms for the slope pavement. The inspection points are listed below:

1. Place these ribbons first, using forms.

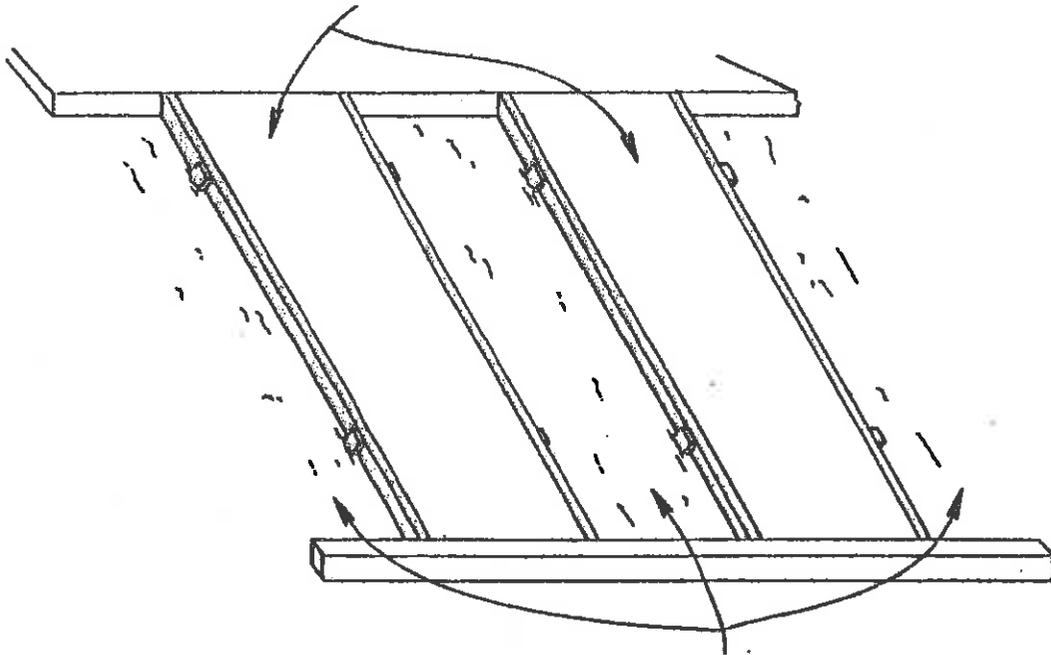

2. Place these after forms are removed.

If 2x4 is used as forms, be sure to check the depth of the slope pavement carefully before placing concrete. (A dressed 2x4 is less than 4 inches.)

The forms must be adequately staked to be secure.

QUIZ

The basic construction steps are listed below. Number them in the proper sequence.

- _____ Ribbons placed in forms.
- _____ Ribbons placed between the ribbons previously placed.
- _____ Toe wall and berm placed.
- _____ Raddi formed and placed.
- _____ Grading between forms.
- _____ Grading between ribbons.

What are the two important points to inspect on the toe wall? _____

Do toe walls slope away from or toward slope pavement? _____

Forms must be _____ so that the line will be straight.

EMBANKMENT

The embankment must be carefully prepared before any concrete is placed. In general, the surface must be firm and well compacted. If the embankment is not compacted, it will settle after the concrete is placed, causing the slope pavement to buckle and break up.

WEEP HOLES

Weep holes are placed in the concrete but they are backed up by a continuous layer of aggregate and filter fabric. This is the shape of filter beds and weep holes currently being specified.

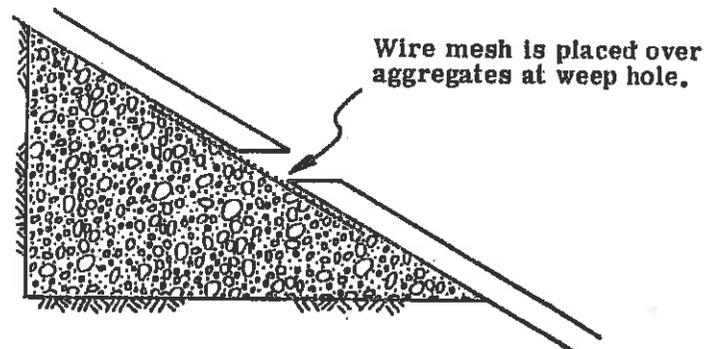

In order to prevent the concrete from setting in the wire mesh, plastic may be placed over the mesh before concrete is placed. Then, when the concrete has set, the plastic is removed through the weep hole.

The weep hole in the concrete is formed by the finishers while the concrete is still plastic. Be sure that the diameter is correct, and that the aggregates and wire are correctly positioned in relation to the weep hole.

JOINTS

Three types of joints are used in slope pavement:

- ▶ expansion joints between the pavement and the berm and walls,
- ▶ construction joints -- cold joints -- between ribbons, and
- ▶ contraction joints -- dummy joints -- formed across the slope.

All the details are in the plans. Look at your detail now.

CONCRETE PLACEMENT

Just before any concrete is placed, check the following:

- ▶ Embankment must be firm, uniform. Have the Contractor tamp any soft spots.
- ▶ Embankment must be wet. A fine spray should be used to wet it. A hard stream of water will dig up the ground.
- ▶ Weep hole aggregate, filter fabric and wire mesh should be in place.
- ▶ Premolded expansion material should be staked in place.
- ▶ The depth must be correct. Check it at several places.
- ▶ Check the form spacing and dimensions one more time.

Now the concrete can be placed. Be sure the Contractor follows these guidelines:

- ▶ Concrete should be placed from the bottom up. This will prevent segregation. If the Contractor does start at the top of the slope, he may need baffles to break the flow of the concrete. And never allow concrete to roll from the top to the bottom. The bucket or chute should move down the slope -- not the concrete.
- ▶ The concrete should have a low slump, approximately 25 to 50 mm (1 to 2 inches).
- ▶ The workmen on the slope should avoid standing in the concrete.
- ▶ The concrete must be sprayed and tamped sufficiently, especially around the edges and in the corners.
- ▶ The finishers should screed and edge the surface as called for. Construction joints are edges with 1/4-inch (6-mm) radius finishing tools.
- ▶ Curing is done the same as for curb and gutter. Membrane curing compound is most common, but be sure that the compound does not streak.
- ▶ Expansion joint material should be exposed. Concrete will slop over onto the joint, but be sure that it is cleaned off and not knocked out of place.
- ▶ Dummy joints should line up. This may be done by using a 1/4-inch (6-mm) nylon rope to form the joints.
- ▶ The spacing is marked at the 2 end ribbons (not on each one). The rope is stretched across the ribbons, then depressed into the concrete. The joints will be uniform, even and better looking.
- ▶ Radii ribbons must be tapered from a bottom width of four feet (1.2m) to a minimum width of one foot (0.3 m) at the top.

QUIZ

You probably will need to refer to the sheet No. A-10 of Fin. Project 000000-00000 to answer some of the questions in this quiz.

In order to avoid settlement in the concrete, you should be sure that the _____ is firm and well compacted.

Behind the weep holes, there are _____, aggregate and _____.

How many rows of weep holes are placed in each slope pavement? _____

What is the layout and spacing of weep holes?

- A. Staggered rows, 8ft (2.45m) horizontal centers, max. 10ft (3.m) vertical
- B. Even rows, 8ft (2.45m) horizontal centers, max. 10ft (3.m) vertical
- C. Staggered rows, L/3 vertical centers, no horizontal spacing requirement

If concrete is placed on the wire mesh, the mesh will set in the concrete and be plugged up. How can this be avoided? _____

QUIZ, continued

Name the joints required in the following locations.

Pavement/Berm _____
Across slope _____
Between ribbons _____
Pavement/End wall _____
Wing wall/Pavement _____

Expansion joints must be _____ - inch (mm) _____ expansion material, sealed with

Construction joints are permitted every _____ feet (meters) across the slope.

Contraction joints (along the slope) are tooled with a _____ at _____ intervals.

When the slope pavement under the bridge is finished, it will have the appearance of many blocks, each with the dimensions of _____.

What is the required edging on construction joints? _____

QUIZ, continued

How and when should embankment be wetted? _____

Should expansion joints be in place before concrete placement or should they be placed while the concrete is still fresh? _____

Which is the best procedure?

- _____ A. Use high slump concrete, place from bottom up.
- _____ B. Use low slump concrete, place from bottom up.
- _____ C. Use low slump concrete, place from top down.

If the Contractor is using a bucket to place concrete, should he move the bucket around a lot -- and place a lot of small piles -- or should he dump the concrete in one place and let it flow into final position? _____

On the radii, the ribbons must be no less than _____ wide at the top.

What should you be sure is avoided during curing compound application? _____

Should the expansion joints be covered with concrete by the finishers? _____

DOCUMENTATION

Miscellaneous concrete structures constructing and inspection are documented on Daily Report of Construction. As an Inspector, you must complete this Report each day -- noting the work items, pay quantities, work accomplished, workforce, equipment and hours worked.

Study this report, and the one on the next page then try the quiz that follows.

Select One: <input type="radio"/> Subcontractor <input type="radio"/> Contractor		STATE OF FLORIDA DEPARTMENT OF TRANSPORTATION DAILY REPORT OF CONSTRUCTION				FORM 700-016-13 CONSTRUCTION - 11/96 Page 1 of 2	
DESCRIPTION OF WORK							
CONTRACTOR:							
OPERATION and LOCATION					TIME (AM/PM?)		
					BEGINNING	ENDING	
PERSONNEL	NO.	HOURS WORKED	MATERIALS RECEIVED				
SUPT.							
FOREMAN							
SKILLED							
SEMI SKILLED							
COMMON							
TRAINEE							
EQUIPMENT (ACTIVE/IDLE)							
A	I	A	I	A	I	A	
	AIR COMPRESSOR		CULTIPACTOR		POWER BROOM	TRUCK, DUMP	
	AIR HAMMER		DRAGLINE		PUMP	TRUCK, FLATBED	
	ASPHALT PAVER		EARTH MOVER		ROLLER, STEEL WHEEL	TRUCK, GREASE	
	ASPHALT DISTRIBUTOR		FRONTEND LOADER		ROLLER, TRAFFIC	TRUCK, LANE STRIPING	
	BACKHOE		HAND LINER		ROLLER, VIBRATORY	TRUCK, PICKUP	
	BULLDOZER		HARROW		ROTARY TILLER/MDR	TRUCK, WATER	
	CONCRETE BUCKET		GENERATOR		SPREADER, BOX	WELLPOINT SYSTEM	
	CONCRETE SAW		MECHANICAL TAMP		SPREADER, SEED		
	CONCRETE SCREED		MILLING MACHINE		SPREADER, FERTILIZER		
	CONCRETE VIBRATOR		MOTOR GRADER		TRACTOR, FARM		
	CRANE, CRAWLER		MULCHER		TRANSPORT		
	CRANE, TRUCK		PILE DRIVER & HAMMER		TRUCK, BUCKET		
ESTIMATED CONTRACT QUANTITY INCREASES TODAY							
ITEM NO.	ITEM	QUANTITY	REMARKS AND CALCULATIONS				
FIN PROJECT NO.:		F.A. PROJECT NO.:		CONTRACT NO.:		DATE:	
				DAY OF WEEK:		CONTRACT DAY:	
DISTRIBUTION ORIGINAL - PROJECT FILE COPY - CONTRACTOR (AS REQUESTED) COPY - DISTRICT CONSTRUCTION ENGINEER							
COPY - FROM P.A. OVERSIGHT						Page ____ of ____	

STATE OF FLORIDA DEPARTMENT OF TRANSPORTATION
DAILY REPORT OF CONSTRUCTION

FORM 788-01-13
CONSTRUCTION - 02/85
Page 1 of 1

STATE JOB NUMBER: 46140-3506	F.A. JOB NO.:	CONTRACT NO.:	DATE:	DAY OF WEEK:	CONTRACT DAY NO.:
		16101	4-24-95	Thur	187

WEATHER CONDITIONS: Clear Partly Cloudy Heavy Clouds Fog
TEMPERATURE: **26° (28°) High** **16° (16°) Low** Temperature Restriction Specification No. _____
WIND: None Slight Strong
RAIN: None Light Heavy Showers
RAIN DURATION: 0-2 h 2-4 h 4-6 h All Day

WORKING CONDITIONS: Excellent Good Fair Poor Bad
DURATION OF ACCEPTABLE CONDITIONS: Acceptable All Day More Than 50% of Work Day Less than 50% of Work Day Unacceptable All Day
SOIL CONDITION: Dry Wet Extremely Wet

EFFECTS OF WEATHER ON MAJOR WORK ITEMS (CHECK CONTROLLING ITEMS):

Major and/or Controlling Work Items	No Effect	Effected Less	Effected More	No Work
	All Day	Than 50% Of Work Day	Than 50% Of Work Day	All Day
_____	<input type="checkbox"/>	<input type="checkbox"/>	<input type="checkbox"/>	<input type="checkbox"/>
_____	<input type="checkbox"/>	<input type="checkbox"/>	<input type="checkbox"/>	<input type="checkbox"/>
_____	<input type="checkbox"/>	<input type="checkbox"/>	<input type="checkbox"/>	<input type="checkbox"/>
_____	<input type="checkbox"/>	<input type="checkbox"/>	<input type="checkbox"/>	<input type="checkbox"/>
_____	<input type="checkbox"/>	<input type="checkbox"/>	<input type="checkbox"/>	<input type="checkbox"/>
_____	<input type="checkbox"/>	<input type="checkbox"/>	<input type="checkbox"/>	<input type="checkbox"/>

GENERAL COMMENTS:

VISITORS: _____

TECHNICIAN'S SIGNATURE AND RATING: <i>Stan J. Jones ET IV</i>	HOURS AT JOB SITE	TOTAL HOURS:
	FROM 7:00 am TO 5:00 pm	9

ENGINEER IN CHARGE (NAME, RANK AND INITIALS):
James E. Jones E II JH

QUIZ

Refer to the Report on the preceding page to answer the questions below.

What was the weather on the day of the Report? _____

What was the quantity of sidewalk placed during the day? _____

How thick was the sidewalk placed? _____

How much concrete was received during the day? _____

What curb work was performed during the day? _____

Was any slope pavement placed? _____

CONGRATULATIONS

You have finished the course in Utility Relocation, Clearing and Grubbing, and Miscellaneous Concrete Structures Inspection. Before you take the Examination, however, there are a couple things you should do:

1. Put this book away for a day or so -- to let the information settle in your mind.
2. Take the Review Quiz.
3. Go back into the course and study the sections that gave you trouble in the Review Quiz.
4. When you feel you are ready, tell your Supervisor that you want to take the Examination.

ANSWERS TO QUESTIONS

Page 10-5

- ▶ 3 ft.
- ▶ 2:1
- ▶ 4 inches
- ▶ 6 inches
- ▶ 10 feet

Page 10-10

- ▶ berm; slope
- ▶ top of shoulder
- ▶ 1 inch per foot (25 mm per 300 mm)
- ▶ stringline from top of shoulder to the toe wall

Page 10-14

- ▶ 3
- ▶ 5
- ▶ 1
- ▶ 6
- ▶ 2
- ▶ 4
- ▶ line and grade
- ▶ away from
- ▶ straight

ANSWERS TO QUESTIONS, continued

Page 10-18

- ▶ embankment
- ▶ filter fabric; No.57; wire mesh
- ▶ two
- ▶ A
- ▶ place plastic between concrete and wire mesh

Page 10-19

- ▶ Expansion
- ▶ Contraction
- ▶ Construction
- ▶ Expansion
- ▶ Expansion
- ▶ 2@ (13 mm); premolded; poured rubber
- ▶ 4 feet (1.23m)
- ▶ 3 (5 mm) radius tool; 2 ft. (0.6m)
- ▶ 2' x 4' (50 mm x 100 mm)
- ▶ 3 inch (5 mm) radius

ANSWERS TO QUESTIONS, continued

Page 10-20

- ▶ fine spray before concrete placement
- ▶ before
- ▶ B
- ▶ move bucket
- ▶ 1 foot
- ▶ streaking
- ▶ no

Page 10-22

- ▶ fair and mild
- ▶ 138.89 sq. yd.
- ▶ 4 inches
- ▶ 15.5 cubic yards
- ▶ forms were set from rt. sta. 105 + 00 to 106 + 25
- ▶ no

CHAPTER ELEVEN

Review Quiz

Things which you have learned in this course are going to help you do a better job as an Inspector. This Review Quiz is designed to help you know how well you have learned. It is also designed to prepare you for the Examination.

Listed below are instructions on how to take the quiz.

1. Do not take this quiz immediately after you finish the course.
2. Do not cram the night before you take the quiz. Remember that the objective is to help you evaluate how well you have learned the material and how well you can think through your everyday work problems.
3. When you take this quiz, make sure that you will not be disturbed for about one hour.
4. Attempt all questions.
5. You may refer to the course material if you get stuck on a question. But first try to reason out the problem.
6. Finally, keep track of your wrong answers. Instructions on how to grade yourself follow the Review Quiz. If you score less than 90% on the quiz, do not be disappointed. Go back and study the course materials once again and reattempt the quiz.

GOOD LUCK

REVIEW QUIZ

Name the two documents you must review before utilities are relocated in the field:

Why is it necessary to hold a preconstruction conference even though the utilities have been relocated?

During a field inspection, you find a telephone line that is not shown on the plans. What should you do?

In general, relocated utilities are installed inside the _____.

Place an "N" next to the characteristics of nonreimbursable work, an "R" next to the characteristics of reimbursable work, and a "B" next to those that apply to both.

- ___ 1. Utility pays for full expense of relocation.
- ___ 2. Utility occupies Department R/W.
- ___ 3. Department occupies Utility R/W.
- ___ 4. Utilities are adjusted to resolve conflicts with construction.
- ___ 5. Department pays part of relocation cost.
- ___ 6. Work is documented in detail on the Utility Diary -- Daily Entry and on Daily Report of Construction.
- ___ 7. Utility is responsible for relocating the utilities.

Match the following.

A. Department

B. Utility

- 1. ___ Owns utilities
- 2. ___ Responsible for relocating utilities.
- 3. ___ Supplies manpower for utility relocations.

What do the two sides of the stake shown tell you?

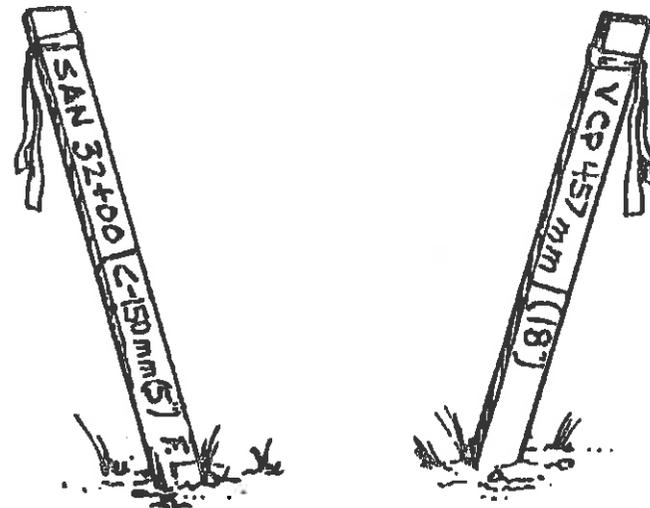

Front

Back

The minimum number of warning signs needed for relocation of a water line is found in the _____

At night, _____-way traffic must be maintained.

List five things that must be checked and recorded during reimbursable relocations or installations.

1. _____
2. _____
3. _____
4. _____
5. _____

Embankment backfill must be compacted in _____ lifts.

How many moisture-density tests are performed for four six-inch (150 mm) lifts? _____

For nonreimbursable utility relocations, where do you document the Utility's workforce and equipment?

For reimbursable work, where do you document the same things?

_____ (noted)
_____ (in-detail)

Are fences considered to be a part of building removal? _____

Mark the following statements about standard clearing and grubbing "T" for true, "F" for false.

- ___ 1. It is required in borrow pits.
- ___ 2. It includes disposal of all stumps and debris.
- ___ 3. It requires all roots and debris to be removed to 1 foot (300 mm) below the ground.
- ___ 4. The ground surface is plowed to a depth of at least 6 inches (150 mm).
- ___ 5. It will not come closer than 3 feet (0.9 m) of the borrow pit R/W.
- ___ 6. Debris may be disposed of within 300 feet (91.4 m) of the R/W when the Contractor has the landowner's permission in writing.

What should be done with boulders that are found in the construction area by the Contractor?

What may be done with boulders found in State-owned borrow pits?
_____ or _____ .

When the Contractor exposes 750,000 sq. ft. (69,677 m²) of erodible earth, what must you do?

What is the minimum clearance height that branches must be trimmed above the roadway?

If burning is prohibited by law, is the Contractor responsible for providing the disposal area?

Is the area subject to approval? _____

Who should the Contractor contact about a diseased orange grove? _____

At what point are utilities removed from buildings? _____

What must be done to abandoned sewer connections? _____

During your final inspection of a building removal by an individual (not the Contractor), you find that the concrete floor was not removed. What should you do? _____

Basically, what must you be sure is done with artesian wells not designed to remain in service?

In general, Contractors can be paid for clearing and grubbing by the:

- A. acre / hectare
- B. ton / metric ton
- C. cubic yard / cubic meter
- D. lump sum

For each of the structures listed below, briefly describe the main purposes they serve.

Barrier wall _____

Curb and gutter _____

Sidewalk _____

Traffic separator _____

Ditch pavement _____

Slope pavement _____

The control mark on the right is for a barrier wall. If the wall is 3.33 ft (1 m) high, what is the distance from the mark on the pavement to the bottom of the barrier wall? _____

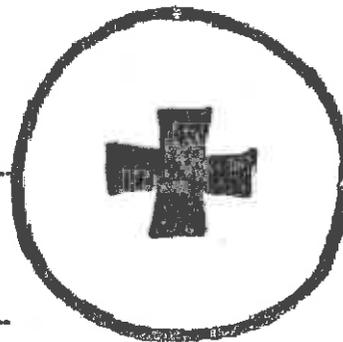

O/S 10' (3m) C
F-3' (F-0.9m) L
37+ 25

Control marks for staking a barrier wall are placed at what interval? _____

What is the height of standard barrier wall above the pavement? _____

Below we will cover your responsibilities for the general inspection of concrete construction.

What should be the condition of a subgrade before concrete is placed on it? _____

When concrete arrives at the job site, you must collect _____.

What should the condition of forms be? _____

Why should wood forms be wetted? _____

Why should forms be oiled? _____

Which of the following should be checked for line and/or grade?

- A. Subgrade.
- B. Stakes.
- C. Forms as they are being erected.
- D. Forms as concrete is placed.

What tool would be used to check the surface uniformity of a sidewalk? _____

Why is it important that miscellaneous concrete structures be as straight and level as possible?

What may happen if barrier wall forms are not weighted down?

Where in a barrier wall is a horizontal construction joint allowed?

Where are expansion joints placed in barrier walls?

Contraction joints in curb and gutter must be placed every _____ feet (meters), except where a lesser interval is required for closure.

What type of joints are needed in concrete curb and gutter that is:

adjacent to asphalt pavement? _____

adjacent to concrete pavement? _____

Which types of traffic separator permit construction joints? _____

Which do not? _____

What are the three important things that you must find in the plans for concrete sidewalks?

What will be used to control the line and grade of a concrete sidewalk placed adjacent to a concrete curb and gutter? _____

What two types of contraction joints are permitted in concrete sidewalks?

When joints in sidewalks are sawed, what are the timing and spacing requirements after finishing?

How are weep holes in ditch pavement located after the concrete has been placed? _____

How many rows of weep holes are placed in ditch pavement that has a 9-foot (2.75-m) bottom and 3-foot (0.9-meter) sides? _____

What is the backing under weep holes:

in ditch pavement? _____

in slope pavement? _____

What are the above covered with? _____

Ditch pavement expansion joints are spaced no more than every _____ feet (meters) and contraction joints are spaced no more than every ____ feet (meters).

Which of the following do you include in your Daily Report of Construction?

- A. Concrete test results
- B. Cylinder numbers
- C. Accumulated pay quantities
- D. Daily pay quantities

List the general steps in slope pavement construction.

1. _____
2. _____
3. _____
4. _____
5. _____
6. _____
7. _____
8. _____

Slope pavement is placed in alternating _____ that are no more than _____ wide in straight sections, and no less than _____ in radii sections.

Concrete in ditch and slope pavement should be placed from the _____ to the _____.

Name the types of joint between slope pavement and:

Wing wall: _____

Berm: _____

End wall: _____

Slope pavement: _____

SCORE YOUR OWN REVIEW QUIZ

The Review Quiz contains 60 possible answers. If you scored 90 percent or better -- that's 54 or more correct answers -- you should be ready for the Examination.

If you had 7 or more wrong answers, take the course again -- and spend more time studying the things that give you trouble. After you have retaken the course, work the Review Quiz again. Your score should be at least 90 percent.

Good luck on the Examination.

ANSWERS TO QUESTIONS

Page 11-2

- ▶ utility agreement; plans
- ▶ to discuss the staking and marking of the utilities; what changes were made and what utility work remains to be done
- ▶ inform the Project Engineer
- ▶ R/W

Page 11-3

- ▶ 1. N
- ▶ 2. B
- ▶ 3. R
- ▶ 4. B
- ▶ 5. R
- ▶ 6. R
- ▶ 7. B
- ▶ 1. B
- ▶ 2. B
- ▶ 3. B
- ▶ sanitary sewer at sta. 32 + 00; 5 feet (1.5 m) cut to flow line from mark on stake; 18" (450 mm) vitrified clay pipe

ANSWERS TO QUESTIONS, continued

Page 11-4

- ▶ Manual on Uniform Traffic Control Devices
- ▶ two
- ▶ 1. labor classification
- ▶ 2. manhours
- ▶ 3. equipment
- ▶ 4. materials
- ▶ 5. elevation
- ▶ 6 inch (150 mm) " 12 inch (300 mm), if approved
- ▶ 2
- ▶ Daily Report of Construction
- ▶ Daily Report of Construction; Utility Diary -- Daily Entry

Page 11-5

- ▶ yes
- ▶ 1. T
- ▶ 2. T
- ▶ 3. T
- ▶ 4. T
- ▶ 5. T
- ▶ 6. F
- ▶ placed in neat piles along R/W line
- ▶ use in embankment; stockpile in borrow area
- ▶ be sure no more is exposed without proper authorization

ANSWERS TO QUESTIONS, continued

Page 11-6

- ▶ 6 feet (5m)
- ▶ yes
- ▶ yes, by Project Engineer
- ▶ Division of Plant Industry
- ▶ point of connection with tie-in
- ▶ plug them
- ▶ be sure contractor removes it as part of clearing and grubbing
- ▶ plug by filling with cement mortar

Page 11-7

- ▶ A; D
- ▶ safety barrier; reduce glare; bridge rail
carry water to inlets
pedestrian traffic
channel traffic
control erosion; reduce maintenance
reduce maintenance; improve appearance
- ▶ 0.33ft (0.10 m)
- ▶ 25 ft (7.5 m)

ANSWERS TO QUESTIONS, continued

Page 11-8

- ▶ 2' 8" (815 mm)
- ▶ graded and wet
- ▶ delivery tickets
- ▶ clean; strong; straight; no holes
- ▶ prevent forms from absorbing moisture from the concrete
- ▶ to prevent concrete from sticking to form
- ▶ all of them
- ▶ a 10 ft.(3.048) straightedge
- ▶ for pleasing appearance to the public

Page 11-9

- ▶ forms will float up
- ▶ between the base and wall
- ▶ bridge ends; to correspond with expansion joints in concrete pavement when placed adjacent to it
- ▶ 10 feet (3 m)
- ▶ contraction; contraction and expansion
- ▶ I and IV; II and V

ANSWERS TO QUESTIONS, continued

Page 11-10

- ▶ location; cross slope; thickness
- ▶ top of curb grade
- ▶ open (formed); sawed
- ▶ within 12 hours, 30 ft. (9m) spacing; within 96 hours, remaining joints
- ▶ by marks or nails in side form
- ▶ 3 rows

Page 11-11

- ▶ 2 cu. ft., (0.014 m³) grade No. 6, aggregates; continuous, aggregate, Grade No. 57
- ▶ galvanized wire mesh
- ▶ 200 ft (60 m); 25 ft (7.5m)
- ▶ D
- ▶ 1. Grade slope
- ▶ 2. Place toe wall and berm
- ▶ 3. Form alternate ribbons
- ▶ 4. Tamp and grade embankment
- ▶ 5. Place alternate ribbons
- ▶ 6. Remove forms
- ▶ 7. Place remaining ribbons
- ▶ 8. Place the radii

ANSWERS TO QUESTIONS, continued

Page 11-12

- ▶ ribbons; 4 feet (1.2m); 1 foot (300mm)
- ▶ bottom; top
- ▶ Expansion
Expansion
Expansion
Contraction

TABLE OF STANDARD INDEXES

<u>Index No.</u>	<u>Page</u>	<u>Description</u>
217	A2	Median Barrier Inlets
281	A3	Ditch Pavement & Sobbing
282	A4	Back of Sidewall Drainage
300	A5	Curb & Curb and Gutter
302	A6	Traffic Separators
410	A7	Concrete Barrier Wall (1 of 22)
410	A8	Concrete Barrier Wall (2 of 22)
515	A9	Turnouts (2 of 6)
13456	A10	Slope Pavement Details (Fin Project No. 000000-0000)

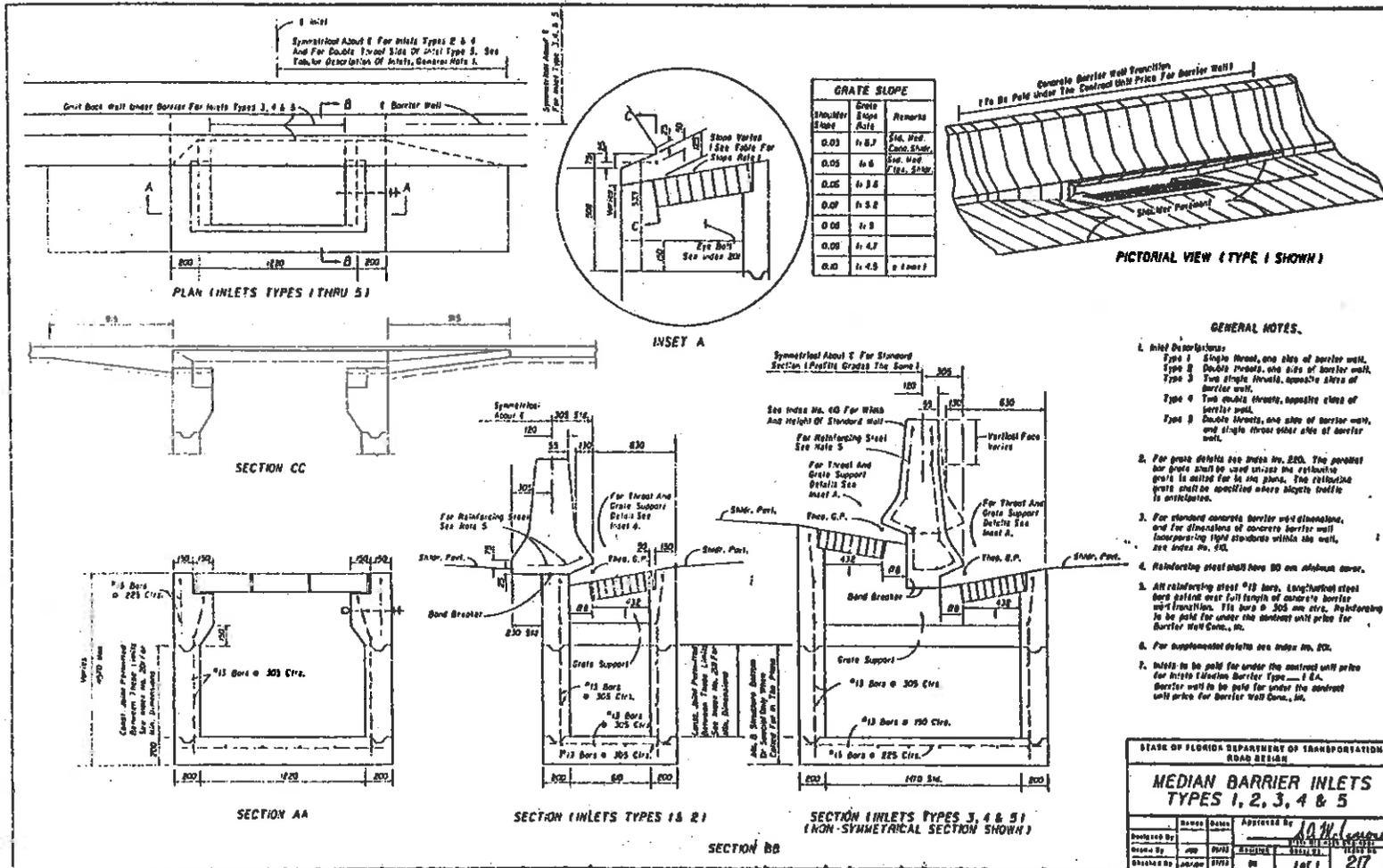

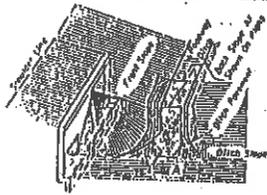

JUNCTION OF ROADWAY DITCH AND LATERAL DITCH

* Self-cement or pipe, apron will not be permitted for this type of construction.

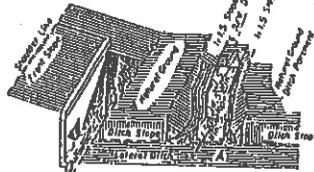

JUNCTION OF R/W DITCH AND LATERAL DITCH

One Row of Sloates Each Side of Overlap Each Side of Slope And On Outer Edges At All Slope Stes 450 Centers (Typical)

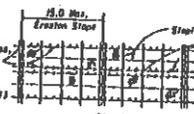

PLAN



SECTION

MATTING FOR DITCH

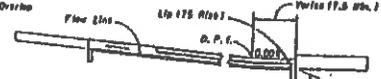

SECTION EE

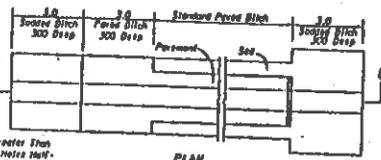

PLAN

PAVED DITCH END TREATMENT

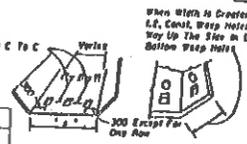

When Width is Greater Than 1.8 Const. Weep Holes Shall Be Placed at 3.0 m Spacing.

GENERAL NOTES

- Type of ditch pavement shall be as shown on plans.
- In concrete ditch pavements, construction joints are to be spaced at 7.5 meters maximum intervals, or as directed by the Engineer. Construction joints may be either formed (construction joints) or casted. No open joints will be permitted.
- Expansion joints with 15 mm preformed joint filler shall be constructed at all inlets, outlets, and at intervals of not more than 80.0 meters.
- Lip at end of ditch pavement shall normally be limited dimensions of 75 mm, or as later grades where there is a decrease in ditch velocity.
- Materials are to be used with all ditch paving. A forecast is not required adjacent to drainage structures.
- When utilized by the Engineer, weep hole spacing may be reduced to 1.8 meters minimum.
- For junction of R/W ditch, roadway and lateral ditch, slope of paving is to 300 mm high minimum.
- For ditch pavements requiring filter fabric the fabric shall be placed directly beneath the pavement for the entire length and width of the pavement. When weep holes with aprons are used the filter fabric shall be placed below the aprons to form a seal and protrude with or overlapping the pavement fabric. See Notes 100 for fabric type and application.
- Ditch pavements requiring reinforcement shall be detailed in the plans.
- Cost of plastic filter fabric to be included in the contract unit price for ditch pavement.

Do Not Construct Weep Holes in Top Area of 4:1 Slootop



SECTION AA

PROFILE OF DITCH PAVEMENT AT LOCATIONS OTHER THAN JUNCTION WITH LATERAL DITCH 75 x 100 Weep Holes

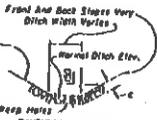
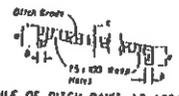

TYPICAL SECTION

Pavement Type	Dimensions			Paymen Unit	Basis of Estimate	Filter Fabric	Velocity Range	References & Remarks
	a	b	c					
Concrete	300	100	7.5	m ²	sq m	1.8	Low-Medium	Section 100 of the Standard Specifications
Asphalt	300	100	7.5	m ²	sq m	1.8	Low-Medium	Section 110
Soil Cement	300	100	7.5	m ²	sq m	1.8	Low-Medium	Section 120
Gravel	300	100	7.5	m ²	sq m	1.8	Low-Medium	Section 130
Gravel with Sloates	300	100	7.5	m ²	sq m	1.8	Low-Medium	Section 140

Notes: All weep holes to be 75 x 100 rectangles or 100 or 125 dia. circular hole. 0.04 m² (1.300 x 300 x 100) of No. 6 aggregate to be placed under each hole. 0.10 m² of gravelized wire mesh 1.8 m spacing shall be placed between the coagulates and the concrete. Cost of filter fabric, aggregate and wire mesh to be included in the cost of ditch pavement.

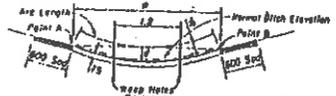

TO REPLACE	a	b	c	No. of Holes	Area (sq m)
1.0 m x 0.5 m Sloate	1.0	0.5	0.5	0	0.0
1.8 m x 0.5 m Ditch	1.8	0.5	0.5	2	1.08
1.8 m x 0.5 m Ditch	1.8	0.5	0.5	2	1.08

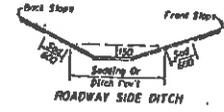

ROADWAY SIDE DITCH



SWALED MEDIUM (No Weep Holes)

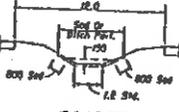

12.0 M MEDIUM

ALTERNATE DITCH PAVEMENT
For use only where ditch slopes are 1:1 or flatter. Points 'a' and 'b' are to be the same elevation and should be used to locate the paved section.

STATE OF FLORIDA DEPARTMENT OF TRANSPORTATION
ROAD DESIGN

DITCH PAVEMENT & SODDING

Designed By	Checked By	Approved By
		<i>[Signature]</i>
Dated	Scale	Sheet No.
		of 2

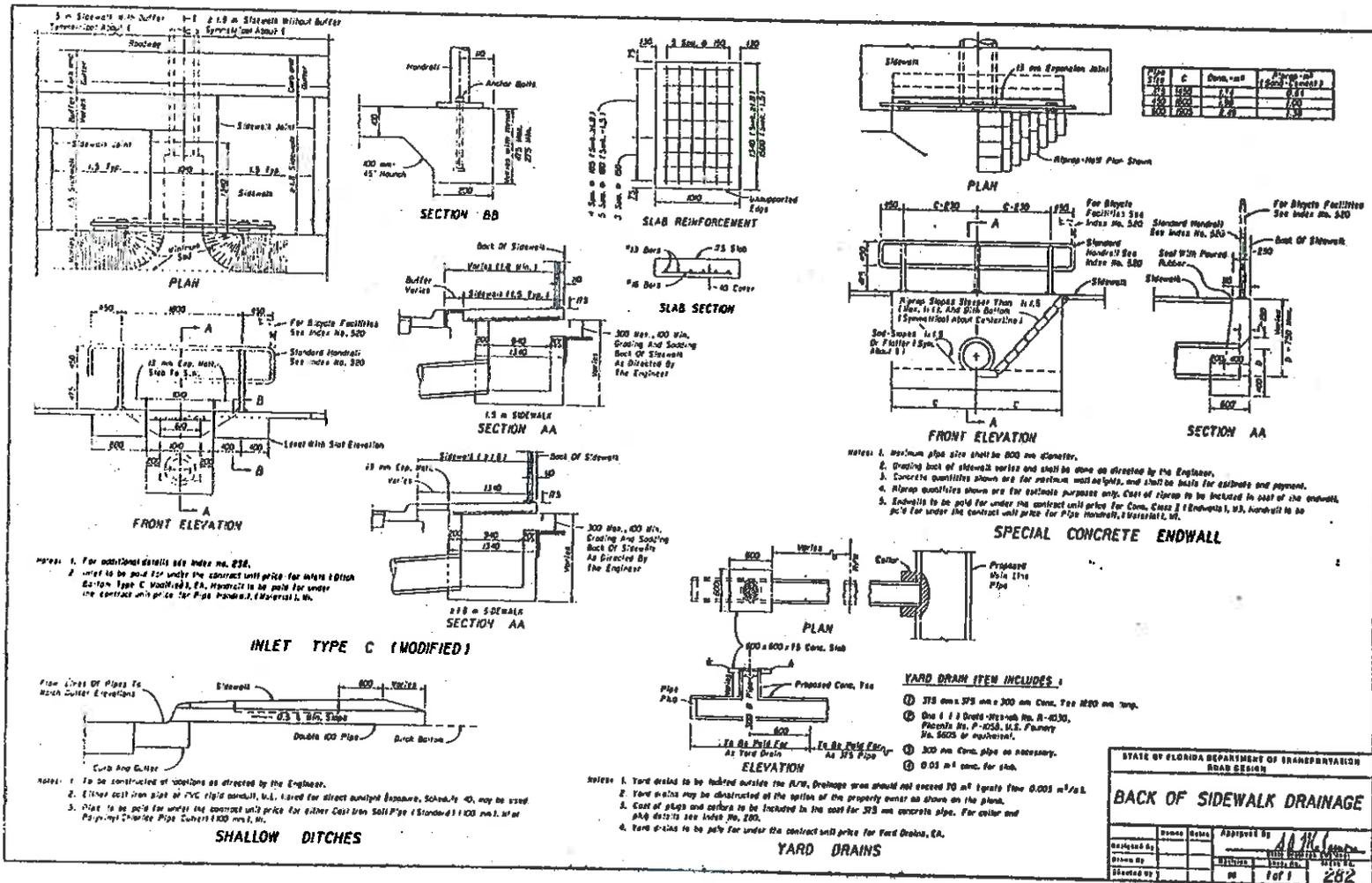

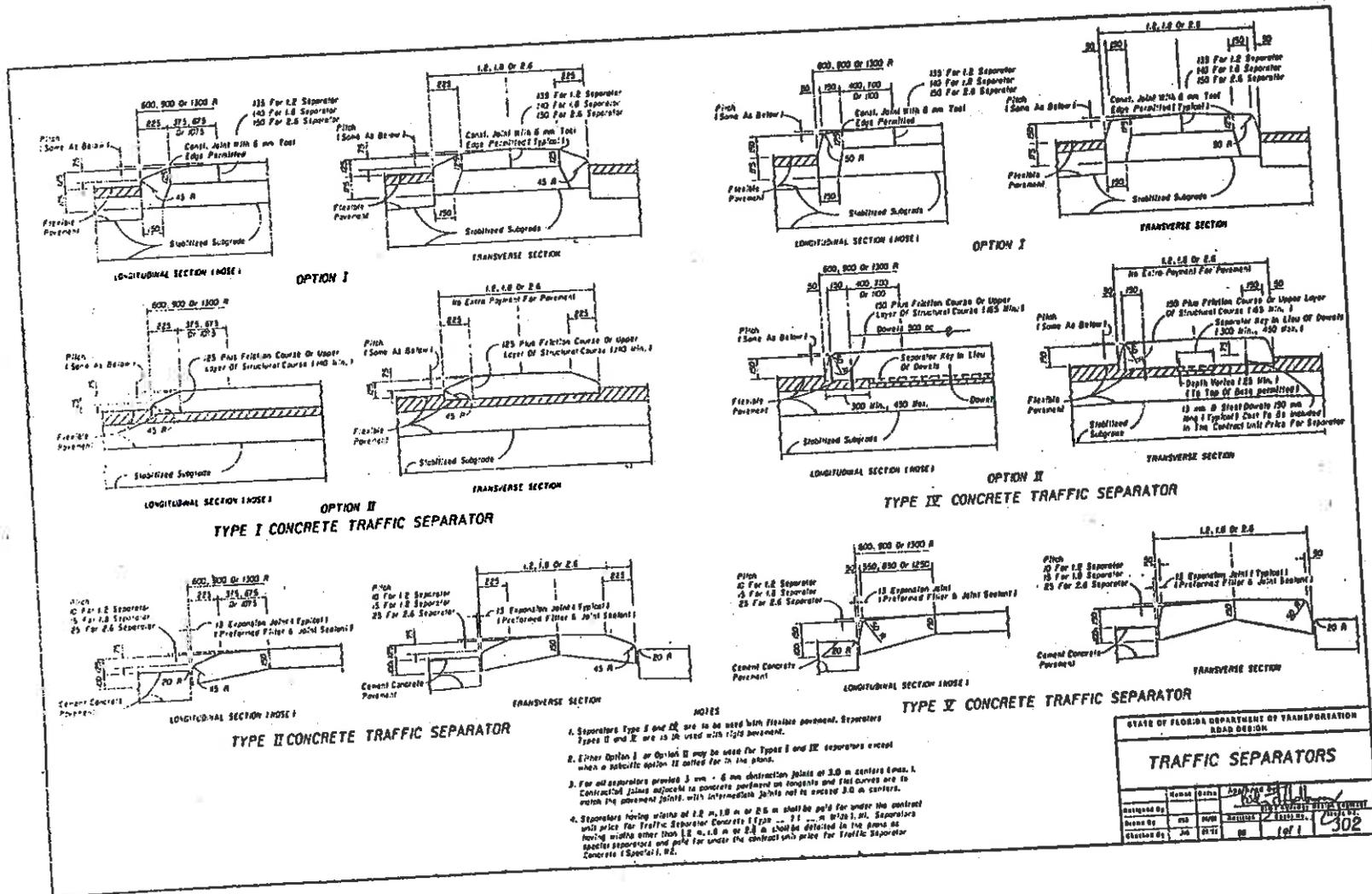

STATE OF FLORIDA DEPARTMENT OF TRANSPORTATION
ROAD DESIGN

TRAFFIC SEPARATORS

Designed By	Checked By	Scale	Date
ms	ms	1:1	10/1
ms	ms	1:1	10/1
ms	ms	1:1	10/1

302

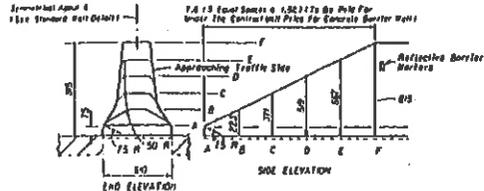

TO BE USED ONLY WHERE TERMINAL LOCATED CLEAR ZONE WIDTH FROM EDGE OF THE NEAR APPROACH TRAFFIC LANE.
**CONCRETE BARRIER WALL TERMINAL
DETAIL II**

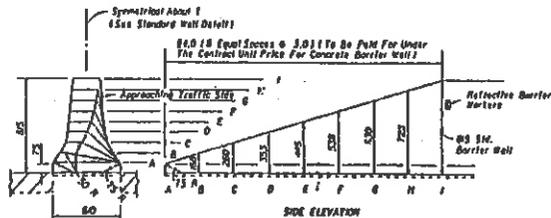

DESIGN SPEED TO MATCH OR LESS
**CONCRETE BARRIER WALL TERMINAL FOR NARROW MEDIAN
DETAIL III**

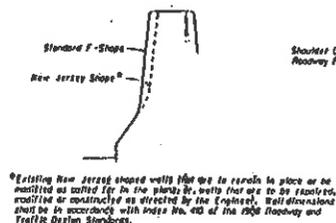
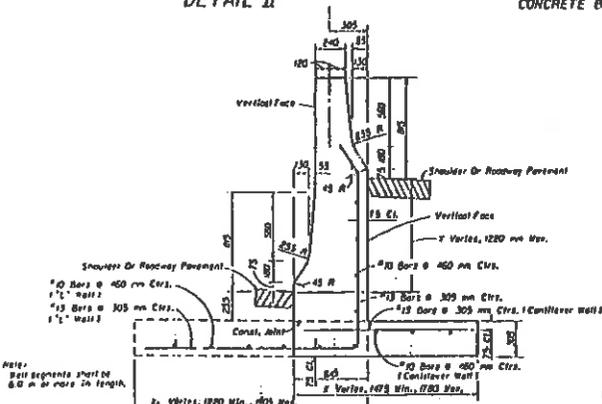

Existing New Jersey shape walls that are to remain in place or be modified as noted for the plans or walls that are to be replaced, modified or constructed as directed by the Engineer, wall dimensions shall be in accordance with Table No. 402 of the 2000 Highway and Traffic Design Standards.
Where standard F-Shape walls about existing NJ Shape walls, face transitions of not less than 1.5 m in length shall be constructed at the end of the F-Shape wall.

WALL FACE SAFETY SHAPES

GENERAL NOTES

- Class II concrete shall be used for all reinforced and plain (non-reinforced) concrete barrier walls except, in moderately and extremely exposed environments, Class III concrete shall be used. Exposed concrete surfaces shall have a Class 3 surface finish in accordance with Section 804 of the Standard Specifications, unless other finish notes for in the plans. The surfaces shall have a Class 3 Applied Finish Coating in accordance with Section 402 only when called for in the plans.
- Concrete barrier wall finished notes for design speeds 200 mph or less shall:
 - be terminated outside clear zone of the approach traffic with 'DETAIL II' end treatment,
 - be terminated within a planned location,
 - be terminated by the use of a crash cushion system,
 - be terminated in conjunction with a multi-bay designed transition to another barrier.
- Expansion joints in wall required only at bridge ends and/or at locations where wall is an integral part of existing or proposed concrete slab wall joints are to match an existing or proposed expansion joint.
- When the barrier is installed adjacent to the pavement the top 300 mm of the substrate shall be compacted to at least 95% of the density as defined in the ASTM D 1557 specifications.
- Cast-in-place barrier wall normally will be a continuous pour without transverse construction joints. Cast-in-place segments with a length >12.0 m shall be joined to adjacent sections by doweling. See Detail D.
- Precast construction is allowed as an alternate to cast-in-place construction.
 - Wall segments >12.0 m in length shall be joined by a transverse joint in accordance with Details C & D. The minimum segment length is 6.0 m.
 - Bedding of the precast sections shall be facilitated by the use of sand-gravel grid or equal method to ensure uniform bearing.
 - Reinforcement may be required for bonding stresses.
- Cost of reinforcing steel and reflective barrier markers shall be included in the contract unit price for concrete barrier wall. See individual details for any item information.
- For barrier wall inlet details see Inletting Std. 87, 88 and 89.

REFLECTIVE BARRIER MARKER SPACING ON WALL		REMARKS
Distance - Edge of Travel Lane to Barrier Wall, m (ft)	Spacing, m (ft)	1. Reflectors shall conform to Section 903-9 of the Standard Specifications.
<1.8	12.0	2. Reflector color (white or yellow) shall conform to the color of the near edge.
1.8 to 2.4	24.0	
> than 2.4	none required	

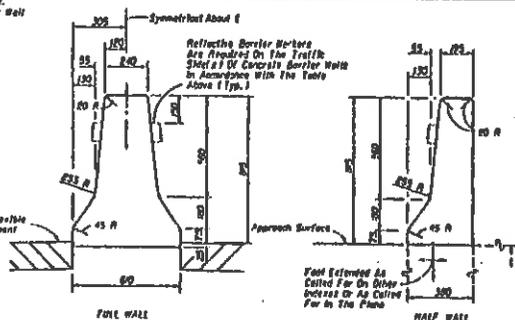

For concrete barrier wall details of pipe, highway lighting and guardrail connections, see other sheets of this book.
Standard barrier to be paid for under the contract unit price for Concrete Barrier Wall, W.

STANDARD BARRIER WALL SECTIONS

Design Criteria:
 Vehicles: HS 19,100 12m, 25', 40' Ax. Load Evaluation Factor - 10% (124.55 kN) Vehicle Force Application: 440 kN Vert. At Top of Toe; 184.55 kN Horiz. At 140 mm Above Foot.
 Unless the plans indicate a specific wall type, either the cantilever wall or the "C" wall may be constructed at the Contractor's option.
 Steel not required in walls of heights 1.0 to 1.80 m when footing and stem cast as one unit, when footing and stem cast separately by construction joints, the footing final surface shall be reinforced with #13 bars @ 60 mm long (distance of the centerline of the stem to 60 mm centers with 330 mm embedment in the footing).
 Cast of the steel and concrete footing to be included in the contract unit price for barrier wall concrete, W.

	Weight (kN/m)	0	150	305	460	60	160	305	460	1200
Cantilever wall	width 2 (mm)	1075	1365	1615	2000	2530	2875	3300	3900	7750
"C" wall	width 2 (mm)	1220	1380	1465	1565	1600	1675	1750	1830	1900

MEDIAN BARRIER WALL FOR SUPERELEVATED SECTIONS OR FOR VARIABLE ROADWAY PROFILE GRADES

STATE OF FLORIDA DEPARTMENT OF TRANSPORTATION
ROAD DESIGN

CONCRETE BARRIER WALL

Designed By: [Signature]
 Checked By: [Signature]
 Approved By: [Signature]

100 MILLER BLVD, TALLAHASSEE, FL 32310
 9000
 410

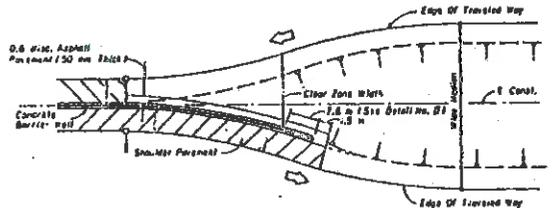

CONCRETE BARRIER WALL TRANSITION BETWEEN WIDE AND NARROW MEDIANS WHEN BARRIER WALL END LOCATED OUTSIDE APPROACH CLEAR ZONE OR HORIZONTAL CLEARANCE

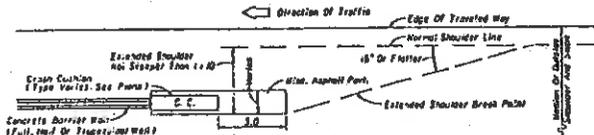

SHOULDER TREATMENT WHEN CRASH CUSHIONS SHIELDING CONCRETE BARRIER WALL END LOCATED INSIDE APPROACH CLEAR ZONE OR HORIZONTAL CLEARANCE

DETAIL A

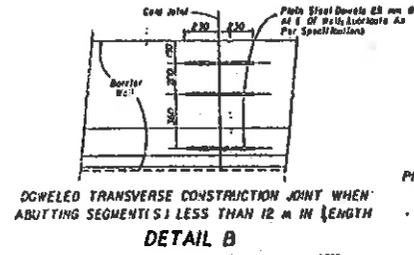

DEWELDED TRANSVERSE CONSTRUCTION JOINT WHEN ABUTTING SEGMENTS LESS THAN 12 M IN LENGTH
DETAIL B

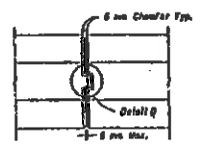

PRECAST BARRIER TRANSVERSE JOINTS
DETAIL C

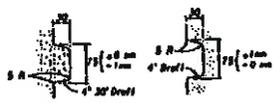

STRAIGHT TONGUE AND GROOVE
DETAIL D

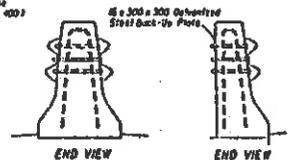
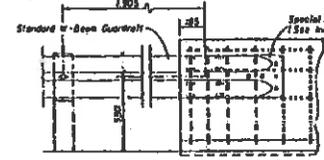

- NOTES**
- End of wall flash mounted connections are not applicable to two-lane two-way facilities. See Sheets 18 and 20 for trailing end connections on two-lane two-way facilities and for approach guardrail connections.
 - Trailing guardrail connections to concrete face safety shield walls within urban areas of the following traffic conditions and mounting methods:
 - One-way traffic trailing condition one side only - Flash mount with end steel post-in-place on back side.
 - One-way traffic trailing condition both sides - Flash mount both sides.
 - For trailing condition one side and approach traffic condition opposite side - See "Trailing Barrier Wall" mounting, Sheet 20.

W-BEAM GUARDRAIL CONNECTION TO CONCRETE BARRIER WALL TRAILING ENDS

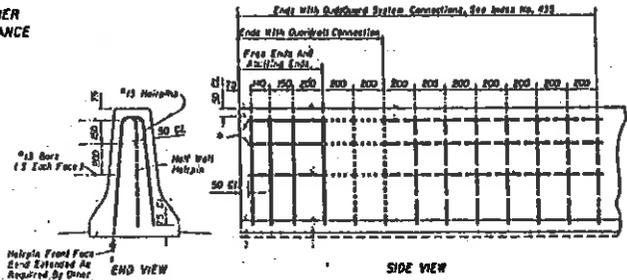

FREE END REINFORCEMENT

STATE OF FLORIDA DEPARTMENT OF TRANSPORTATION					
ROAD DESIGN					
CONCRETE BARRIER WALL					
Designed By	Checked By	Date	Scale	Sheet No.	Total No. of Sheets
Drawn By	Checked By	Date	Scale	Sheet No.	Total No. of Sheets
Checked By	Checked By	Date	Scale	Sheet No.	Total No. of Sheets
				2 of 22	416

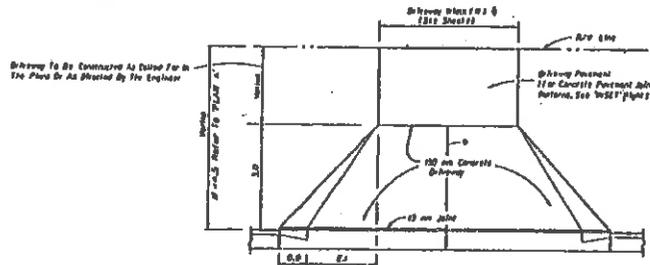

PLAN C
TURNOUT WITHOUT SIDEWALK

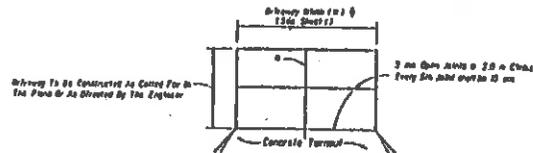

JOINT PATTERN WHEN CONCRETE DRIVE CONSTRUCTED
INSET

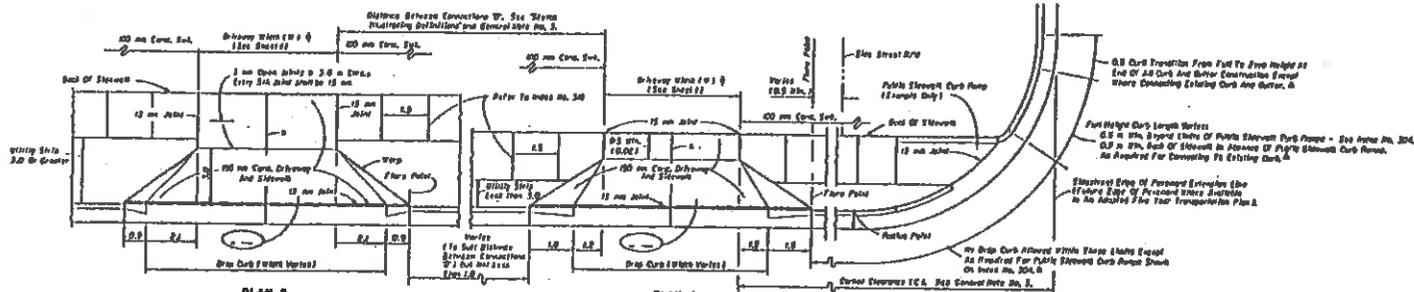

PLAN B
TURNOUT WITH SIDEWALK AND
UTILITY STRIP (3.0 m OR GREATER)

PLAN A
TURNOUT WITH SIDEWALK AND
UTILITY STRIP (LESS THAN 3.0 m)

Footnotes:

1. 100 mm wide joints shall be constructed with preformed joint filler.
2. 3 mm gaps shall be placed at 1.5 m intervals in the driveway and 1.5 m intervals in the curb and gutter in each joint in driveways.
3. When connecting to sidewalk curb and gutter sections, the no drop curb shall extend 300 mm to the sidewalk curb point, with or without curb and gutter, no driveway should overlap on the street surface.
4. Driveways 100 mm wide shall be of a uniform width 1.5 m to the right of any line.
5. A pre-numbered identification of a flared driveway type availability noted for in the plans, see sheets 3 and 4.

SPECIAL NOTES FOR URBAN FLARED TURNOUTS

1. Driveway 100 mm concrete pavement and curb shall meet the curbline and sidewalk requirements of Sections 322 and 323 respectively of the FDOT Standard Specifications. The driveway foundation shall meet the requirements of Subsection 322-4.
2. For details of curb curb and gutter connections refer to sheets No. 302 and 303 respectively.
3. Street curbs are constructed within existing curb and gutter, no existing curb and gutter shall be removed other than the street joint beyond the curb point or to the extent that no remaining section is less than 1.5 m. Curb and gutter shall be constructed in accordance with these two sheets.
4. Curb for preformed joint filler shall be included in the curb for the concrete pavement concrete driveway, 100 mm wide.
5. For details with regard to the requirements under the "Summary of Standards Requirements for Turnouts", the "Summary Notes", the details of "Road Turnout Construction" and the details of "Details of Curb & Guttering, Identification and Basic All Intersections".

DESIGN NOTES FOR URBAN FLARED TURNOUTS

1. Driveways indicated as "Access Approaches" are those with slopes that are used primarily for fire trucks.
2. The sidewalk flared driveways in this detail may not be constructed within the curb, but alternative to the opening features, shall be within the curb and gutter.
3. When curbs are flared driveways are to be constructed, the type and height shall be the same as the sidewalk curb and gutter.

Driveways indicated as "Shoulder Approaches" are those with slopes that are used primarily for emergency vehicles.

Driveways indicated as "Shoulder Approaches" are those with slopes that are used primarily for emergency vehicles.

URBAN FLARED TURNOUTS

Refer See sheet 1 for GENERAL NOTES

STATE OF FLORIDA DEPARTMENT OF TRANSPORTATION
ROAD DESIGN

TURNOUTS

Sheet No.	Scale	Date	By	Checked	Approved
100	1:1	10/15/11	J. J. ...	J. J. ...	J. J. ...
101	1:1	10/15/11	J. J. ...	J. J. ...	J. J. ...
102	1:1	10/15/11	J. J. ...	J. J. ...	J. J. ...
103	1:1	10/15/11	J. J. ...	J. J. ...	J. J. ...

SLOPE PAVEMENT DETAILS

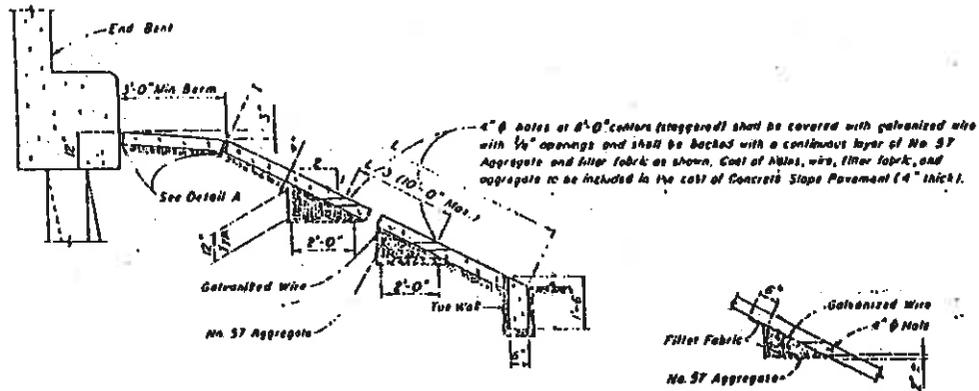

SECTION THRU FORWARD SLOPE

DRAIN DETAIL

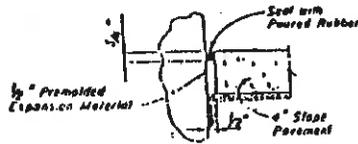

DETAIL A

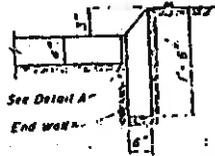

SECTION THRU END WALL

- NOTES.**
- 1 Slope pavements shall be tested with a double $\frac{1}{2}$ " radius tool at 2' intervals along the slope and at 4' across the slope. Construction joints will be permitted or joints as directed by the Engineer.
 - 2 Detail A applies to all contacting surfaces of slope pavement of end bents, end walls, toe walls, and both edges of berm.

SLOPE PAVEMENT DETAILS			
DIAZ BECKING & ASSOCIATES, INC. ENGINEERING FIRM		DATE: 11-1-59	
STATE OF FLORIDA DEPARTMENT OF TRANSPORTATION			
DIVISION OF HIGHWAYS			
FLORIDA'S TURNPIKE OVER HOLLY BLVD.			
PROJECT NO.	SECTION NO.	DATE	BY
DESIGNED BY	C.H.	CHECKED BY	J.A.R.
APPROVED BY		DATE	11-1-59
DRAWN BY			SCALE
C.H.			AS SHOWN

This document was promulgated at an annual cost of \$17.17 per copy to provide training for the Construction of highway transportation facilities by the Department of Transportation, Consultants, Contractors and the Citizens of the State of Florida.