



Florida Department of
TRANSPORTATION

MOT Session 2023 Construction Academy

**Olivia Townsend, P.E.
Construction Office**

Outline

2023 Construction Academy - MOT Session

- CPAM
- Recent Changes
- Process Review Findings
- Group Activity



Florida Department of
TRANSPORTATION

Construction Project Administration Manual (CPAM)

In this section, we will look at the various CPAM chapters related to Temporary Traffic Control and Maintenance of Traffic.

CPAM 9.1 - MAINTENANCE OF TRAFFIC AND SAFETY

- Establishes the standard for inspection and review of MOT operations

Topic No. 700-000-000
Construction Project Administration Manual
Maintenance of Traffic

Effective: July 1, 2002
Revised: June 29, 2022

Section 9.1

MAINTENANCE OF TRAFFIC AND SAFETY

9.1.1 Purpose

To establish a uniform standard for inspection and review of Maintenance of Traffic (MOT) operations used in construction projects.

9.1.2 Authority

Section 20.23(3)(a) and 334.048(3), Florida Statutes (F.S.)

9.1.3 References

FDOT Specifications, [Section 8](#) and [Section 102](#)

[Manual on Uniform Traffic Control Devices \(MUTCD\), Part VI](#)

[FDOT Standard Plans, Topic No. 625-010-003](#)

9.1.4 General

The Department oftentimes uses consultants in administering construction projects through engineering contracts. The authority of the Senior Project Engineer on Consultant Construction Engineering Inspection (CCEI) projects is identical to the Department Resident Engineer and shall be interpreted as such. Likewise, the role of the Consultant's personnel is identical to the Department's project personnel.

9.1.5 Selection of Traffic Control Plan (TCP)

A Traffic Control Plan (TCP) is included with each Department construction contract. The Contractor will furnish a letter to the Resident Engineer stating whether they plan to use the Department designed TCP or will submit an alternate TCP for approval. The alternate TCP must be signed and sealed by a Professional Engineer licensed by the State of Florida and shall be reviewed, discussed, and approved by the Resident Engineer.

When the Contractor proposes a modification to the TCP, particular attention must be given to the utility adjustment plan of the project and Utility Work Schedules. If the proposed TCP modification affects the Utility Work Schedule or

Selection of Traffic Control Plan (TCP)

- Section 9.1.5
- A TCP is should be included for each contract
- Contractor will furnish a letter whether they plan to use the Department designed TCP or will submit an alternate TCP for approval
 - Alternative TCPs are covered in Spec 102-4

Selection of Traffic Control Plan (TCP)

- Alternate TCPs
 - Must be signed and sealed by a FL P.E.
 - Be reviewed, discussed, and approved by the Resident Engineer
 - Coordinated with the District Design, District Traffic Operations, District Utilities, and the District Construction Offices
 - A new Utility Work Schedule must be executed, if the change effects the Utility Work Schedule or the planned utility adjustments
 - Notify Emergency Services in advance of any major modifications affecting traffic flow or patterns
 - **The Contractor cannot begin work under the alternate TCP until it has been approved!**

Discussion of Traffic Control Plan at Pre-Con

- Section 9.1.6
 - Must be reviewed and discussed at the pre-construction conference
 - Include reviewing the different phases of work and the provisions to maintain traffic during each phase
 - Note any errors or omissions for corrective action
 - Clarify the Contractor's role in implementing any corrective actions
 - This ensures that needed changes are performed with minimal disruption to work activities
 - A list of trained flaggers must be submitted before construction begins

CPAM 9.1 - MAINTENANCE OF TRAFFIC AND SAFETY

Discussion of Traffic Control Plan at Pre-Con

- Section 9.1.6
- In addition to the topics on the previous slide, the discussion must include the following topics if they apply to the project:
 - Inspections performed by the Contractor and corrective actions taken
 - Responsibilities of the Worksite Traffic Supervisor (WTS)
 - The Contractor's work notification to the Engineer
 - Traffic safety
 - Changes to the TCP
 - Independent Channelizing Device Supplier
 - Sign installations and removal or covering of existing signs
 - Installation and removal of pavement markings
 - Crash reporting
 - Night work
 - Flaggers
 - Motorist Awareness System (MAS)
 - Work zone clearances
 - Inactive work zones
 - PCMS, etc.
 - Traffic Control Law Enforcement Officers
 - Speed Control Law Enforcement Officers
 - Pedestrian and ADA accommodations, including proper closure of sidewalks in the construction area
 - Impacts on utilities adjustments and/or schedule
 - ***Access to the Department's Lane Closure Notification System***

CPAM 9.1 - MAINTENANCE OF TRAFFIC AND SAFETY

Work Zone Inspections

- Section 9.1.8
- ***Project personnel shall perform work zone inspections***
- ***Document all deficiencies in the weekly MOT Inspection Review Report, Form No. 700-011-37***
 - Discuss any deficiencies identified with the Contractor
 - Issue verbal warnings, deficiency warning letters and deficiency letters, as appropriate
 - The Contractor's WTS must also perform inspections of the project
 - **It is recommended that project personnel should perform work zone inspections with the WTS**
 - If deficiencies are not corrected, use the Contractor's Past Performance Rating, Section 2, to enforce compliance

CPAM 9.1 - MAINTENANCE OF TRAFFIC AND SAFETY

Department's Lane Closure Notification System

- Section 9.1.7
- ***Also known as: LCNS or One.Network***
- CEI should collect the names, email addresses, and certificates of training for the WTS (and alternates, if applicable) who will require access to the Department's Lane Closure Notification System at the pre-construction conference
 - Submit the information collected to the Construction Project Manager (CPM).
 - CPM coordinates with the District Construction Office's Lane Closure Notification System User Administrator for account generation

CPAM 9.1 - MAINTENANCE OF TRAFFIC AND SAFETY

Department's Lane Closure Notification System

- Section 9.1.7
- ***Also known as: LCNS or One.Network***
- CEI are to verify that the WTS has entered the required lane closure information into the Department's Lane Closure Notification System at the start and end of each lane closure.
- ***CEI may need to enter or update lane closure information on behalf of the Contractor in the event of an emergency or device failure***

Department's Lane Closure Notification System

- Section 9.1.7
- ***Also known as: LCNS or One.Network***
- CEI that need access to the LCNS must:
 - Complete the training course for Department's Lane Closure Notification System in Learning Curve
 - Submit an Automated Access Request Form (AARF) for ***Read/Write*** access

CPAM 9.1 - MAINTENANCE OF TRAFFIC AND SAFETY

Actions Due to MOT Deficiencies or Safety Concerns

- Section 9.1.9
- MOT deficiencies that are an immediate safety deficiency (i.e. severe and life-threatening hazard) require immediate corrective action by the Contractor
- If the CEI determines that any activity of the Contractor poses an imminent hazard to the public, direct the Contractor to immediately cease the activity and to close the affected lanes of traffic until the deficiency is addressed

CPAM 9.1 - MAINTENANCE OF TRAFFIC AND SAFETY

Actions Due to MOT Deficiencies or Safety Concerns

- Section 9.1.9
- When defects, including but not limited to, structural cracks, are initially detected during bridge construction, the engineer of record, construction engineering inspector, design-build firm, or local agency that owns or is responsible for the bridge construction has the authority to immediately close the bridge to construction personnel and close the road underneath
- Failure by the Contractor to correct the safety deficiency immediately is basis to suspend project operations and obtain other means to correct the hazard
 - Document the deficiency with photographs sufficient to support the action

CPAM 9.1 - MAINTENANCE OF TRAFFIC AND SAFETY

Actions Due to MOT Deficiencies or Safety Concerns

- Section 9.1.9
- Not all MOT deficiencies rise to the level of severe and life-threatening hazard!
 - The Contractor has 24 hours to correct these types of deficiencies
 - If corrective action on the deficiencies of which the Contractor has been given written notification has not been corrected within the 24-hour time limit, deduct payment for the uncorrected areas until corrective action is made
 - Use the Contractor's Past Performance Rating, Section 2, Form No. 700-010-25 to enforce compliance
 - WTS can be disqualified if corrective action is not completed within the 24-hour time limit on three notifications to the Contractor within a 12-month period

CPAM 9.3 - WORK ZONE TRAFFIC INCIDENT EVALUATION AND REPORTING

- Standardizes procedure for reporting traffic crashes that occur in work zones
- FHWA requires that each State develop a system to report traffic crashes in construction work zones

Topic No. 700-000-000
Construction Project Administration Manual
Maintenance of Traffic

Effective: July 1, 2002
Revised: October 20, 2022

Section 9.3

WORK ZONE TRAFFIC INCIDENT EVALUATION AND REPORTING

9.3.1 Purpose

To standardize a procedure for reporting traffic crashes that occur in construction work zones and to analyze construction work zone operations at crash sites.

9.3.2 Authority

[Section 334.048\(3\), Florida Statutes](#)

[Section 20.23\(3\)\(a\), Florida Statutes](#)

9.3.3 References

[Title 23 Code of Federal Regulations \(CFR\), Part 630, Subpart J](#)

9.3.4 Background

The Federal Highway Administration (FHWA) requires that each State develop a system to report traffic crashes in construction work zones. The crash reports are reviewed to locate and isolate problem areas to evaluate and enhance the safety measures in the work zone, if deemed necessary.

9.3.5 Identification of Traffic Crashes

Resident Level Responsibilities

- (1) When a traffic crash occurs within a work zone and is brought to the attention of the Project Administrator through actual observation, notification by others, or through signs of a crash aftermath (i.e. debris, extensive damage to work zone devices, etc.), contact state or local law enforcement agencies and/or county traffic engineering departments to obtain crash reports.
- (2) Upon identification of a crash, the Project Administrator will conduct an evaluation of

Identification of Traffic Crashes

- Section 9.3.5
- When a traffic crash occurs within a work zone, contact state or local law enforcement agencies and/or county traffic engineering departments to obtain crash reports.
 - Crashes can be identified by actual observation, notification by others, or through signs of a crash aftermath (i.e. debris, extensive damage to work zone devices, etc.)
- Conduct an evaluation of the maintenance of traffic features and devices in the immediate area of the crash site

Reporting Traffic Crashes

- Section 9.3.6
- Complete Engineer's Maintenance of Traffic (MOT) Evaluation at Crash Site Form No. 700-010-64, along with detailed diagrams and narratives.
- Minor crashes
 - Include skid marks, damaged barricades, etc., and crashes in which there are no injuries or fatalities and less than \$1,000 of property damage
- Major crashes
 - Crashes in which there are injuries, fatalities, or result in more than \$1,000 of property damage

Reporting Traffic Crashes

- Section 9.3.6
- If a major crash occurs or multiple minor crashes occur in the same vicinity, then the TCP and traffic movements should be analyzed to determine the cause and subsequent corrective action
- Photos should clearly portray the MOT setup and roadway conditions in the immediate vicinity of the crash site and any resulting property damage.
 - Examples: impacts or damage to temporary barrier, crash cushions and other roadside safety hardware, traffic markings and signage, and vehicle damage

Reporting Traffic Crashes

- Section 9.3.6
- Take appropriate corrective action immediately and note it on the form
- Make sure to include any other supporting documentation, such as crash reports or driver information exchange reports, to the Engineer's MOT Evaluation at Crash Site Form.
 - If a crash report contains information contrary to the facts that project personnel are aware of, and the crash report is correct, amend the Engineer's MOT Evaluation at Crash Site Form.
 - If it is unclear if the crash report is correct, acknowledge the discrepancies on the form.
- Discuss crashes and subsequent corrective actions at the weekly Progress Meetings

MOT Evaluation at Crash Site

- Section 9.3.7
- Make sure to evaluate all possible factors to determine the cause of the crash
- Make corrections that will reduce the probability of additional crashes
 - A crash does not automatically mean that a change in work zone traffic controls is required
 - Crashes usually are the result of a combination of factors.
 - A night inspection is required if the crash occurred at night.
 - List any corrections or enhancements on the form and document the action on the Daily Work Report in Site Manager
 - Do not make changes to the TCP which will change traffic patterns or movements without the approval of the Resident Engineer.

- The Engineer's MOT Evaluation at Crash Site Form should be prepared with photos attached and distributed within two weeks of the incident.
- Email a copy of the Engineer's MOT Evaluation at Crash Site Form and other supporting documentation to the State Construction Engineer and State Construction Specialty Engineer



Florida Department of
TRANSPORTATION

Recent Changes

Let's look at some recent changes to the Standard Specifications.

Recent Specification Revisions (July 2023)

- Pedestrian and Bicycle Accommodations
 - Clarified the expectations for supplying pedestrian detour or temporary pedestrian way



102-3.4 Pedestrian and Bicycle Accommodations: Provide accommodations for pedestrians as shown in the Temporary Traffic Control (TTC) plans or as directed by the Engineer. Accommodate pedestrians with a safe, accessible travel path around work sites separated from mainline traffic in compliance with the Americans with Disabilities Act (ADA) Standards for Transportation Facilities (*i.e., stable, firm, slip-resistant, and free of any obstruction or hazards such as holes, debris, mud, construction equipment, and stored material*). When a work operation requires a sidewalk or pedestrian way closure for 60 minutes or greater, provide a pedestrian detour or temporary pedestrian way. Provide and maintain pedestrian detours and temporary pedestrian ways that are ADA-compliant as described above.

Recent Specification Revisions (July 2023)

- Traffic Control

- Use the Temporary Traffic Control Plan (TTCP)
 - If TTCP does not address condition, use Standard Plans
 - If Standard Plans does not address condition either, use MUTCD and Index 102-600

102-5 Traffic Control.

102-5.1 MUTCD: Comply with the requirements in Part 6 of the MUTCD.

102-5.2 Temporary Traffic Control Plan: The Temporary Traffic Control Plan (TTCP) is the portion of the Plans describing the measures to be used for conveying road users through the work zone. Use the TTCP to maintain traffic for the duration of the work. For situations or field conditions not addressed by the TTCP follow the Standard Plans. For all other applications, comply with the MUTCD and Standard Plans, Index 102-600. Device location or the number of devices, may be adjusted as recommended by the Work Zone Traffic Supervisor and approved by the Engineer.

Recent Specification Revisions (July 2023)

- Existing ITS Maintenance

- Established a pay item for this work

102-9.16 Existing ITS Maintenance: Provide maintenance at existing ITS locations. Diagnose any loss of functionality within 8 hours. Restore any loss of functionality within 24 hours. The Engineer may extend the allowable downtime beyond 24 hours. Configure and install Department furnished equipment as necessary. Ensure that all stand-alone functions of replaced ITS devices are tested as detailed in the Contract Documents and as approved by the Engineer. Perform the test in the presence of the Engineer.

Recent Specification Revisions (July 2023)

- Trailer Mounted Device Payment
 - Add provision for payment for up to two inactive days
 - i.e. Pay for Saturday and Sunday, if active Thursday, Friday AND Monday, Tuesday
 - Add provisions for payment due to inclement weather
 - Applies to:
 - Arrow Board
 - PCMS
 - Portable Regulatory Sign
 - Radar Speed Display Unit

102-11.13 Arrow Board: The quantity to be paid at the contract unit price will be for the number of arrow boards certified as installed/used on the project on any calendar day or portion thereof within the Contract Time. *Payment will be made for up to two inactive days where the arrow board is used on the two days preceding and following the inactive days as authorized by the Engineer. Payment for additional days may be authorized by the Engineer due to inclement weather.*



Recent Specification Revisions (October 2022)

- LCNS

- WTS or designee must be trained
 - Available at <https://info.one.network/fdot-live-link-resources>
 - Less than 15 minutes to get trained!
- Phone or tablet with internet access is required
- Entry is to be in accordance with 102-3.3

102-3.2 Worksite Traffic Supervisor: *Provide the Worksite Traffic Supervisor or designee with a tablet or smartphone with internet access for*

recording information into the Department's lane closure notification system. ...

105-8.3 Temporary Traffic Control (Maintenance of Traffic) Personnel: Worksite Traffic Supervisors, flaggers, and other personnel responsible for work zone related transportation management and the Worksite Traffic Supervisor is to perform the following duties:

1. In accordance with the Department's Temporary Traffic Control (Maintenance of Traffic) Training Handbook located at the following URL address:

2. <https://www.fdot.gov/roadway/TTC/Default.shtm>. Is on site during all set up and take down.

3. *Worksite Traffic Supervisor shall inspect and obtain training and certification for the Department's lane closure notification system immediately after set up. During operations with lane closures, the Worksite Traffic Supervisor or on-site designee shall record*

lane closure information into the

Department's lane closure notification system in accordance with 102-3.3.

3. Is on site during all nighttime operations ensuring proper temporary traffic control

Recent Specification Revisions (October 2022)

- LCNS
 - Planned closures
 - Within 5 minutes
 - First Cone Down
 - Last Cone Up

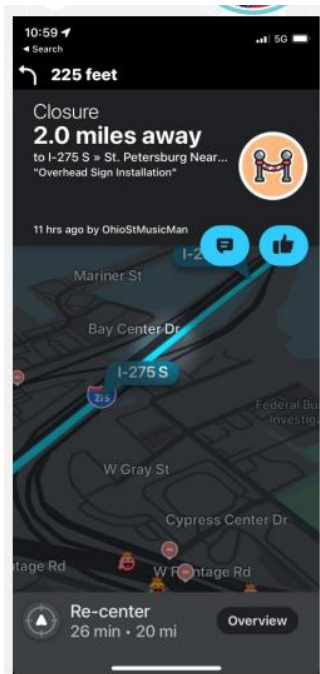

102-3.3 Lane Closures: ...

Record information for planned lane closures, including but not limited to begin and end lane closure times and locations, into the Department's lane closure notification system.

Closure information is to be recorded within five minutes of placing the first channelizing device and removing the last channelizing device associated with the closure.

At the preconstruction conference, submit a request for access to the Department's lane closure notification system to the Engineer. Include the WTS's or designees' name, email address, and a copy of the individual's certification of training for the Department's lane closure notification system. For change of access requests, submit a request to the Engineer at least ten calendar days in advance of when the change is needed.

Information recorded in Department's lane closure system is for public information purposes and will not be used for contract administration.

Recent Specification Revisions (October 2022)

- LCNS

Lessons Learned:

- Inspection staff should follow CPAM provisions for generating their accounts and verifying that contractor is inputting closures correctly
 - This means checking each closure at start/finish every time!!
- Timeliness = good data quality
 - Entering lane closure information within the 5-minute window is still a challenge

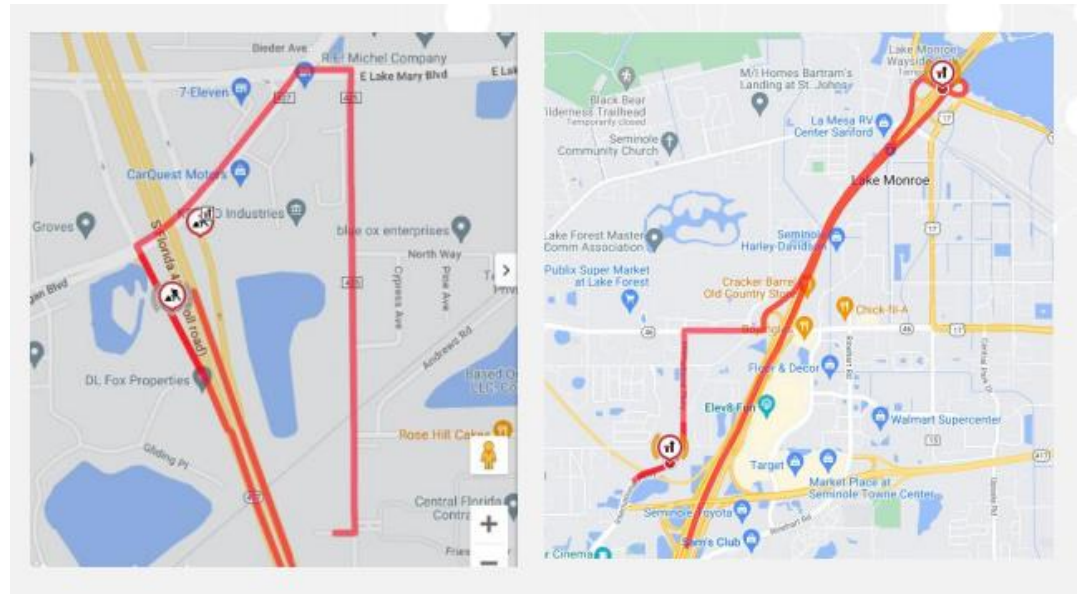



Process Review Findings

In this section, let's take a look at some common issues we see during process reviews.

Process Review Findings

- Common Issues
 - Device Quality
 - Pavement Marking Issues
 - Pedestrian Accommodation
 - Barrier Installation
 - Snag Hazards
 - Deflection Space
 - Crash Cushion Installation
 - APL Numbers

Process Review Findings



Unacceptable

A channelizing device is considered unacceptable if it meets any of the following conditions:

- Punctures and large areas of staining asphalt splatter or cement slurry that cannot be cleaned due to abrasions or discoloration.
- There is noticeable fading of the device's color.
- Large areas of missing or stained reflective material.
- Substantial deformation of a device, which reduces the original dimensions, or the device has lost the intended shape.
- Several dents or fractures that affect their stability or ability to retain the reflective sheeting.



Various drums had lights attached and were not properly maintained. Specification 102-9.1 prohibits lights on TTC devices and requires all devices to meet Acceptable standards as outlined in the ATSSA's Quality Guidelines for Temporary Traffic Control Devices and Features.



Process Review Findings



Spray paint was used for lettering on ‘Road Work Ahead Next ___ Miles’ signs. Specification 994 requires all sheeting, process inks and overlay materials shall be listed as a system on the Department’s Approved Product List (APL).

Process Review Findings



Type III barricades were not properly maintained.

Specification 102-9.1 requires all temporary traffic control devices to meet Acceptable standards as outlined in the ATSSA's Quality Guidelines for Temporary Traffic Control Devices and Features.

Process Review Findings

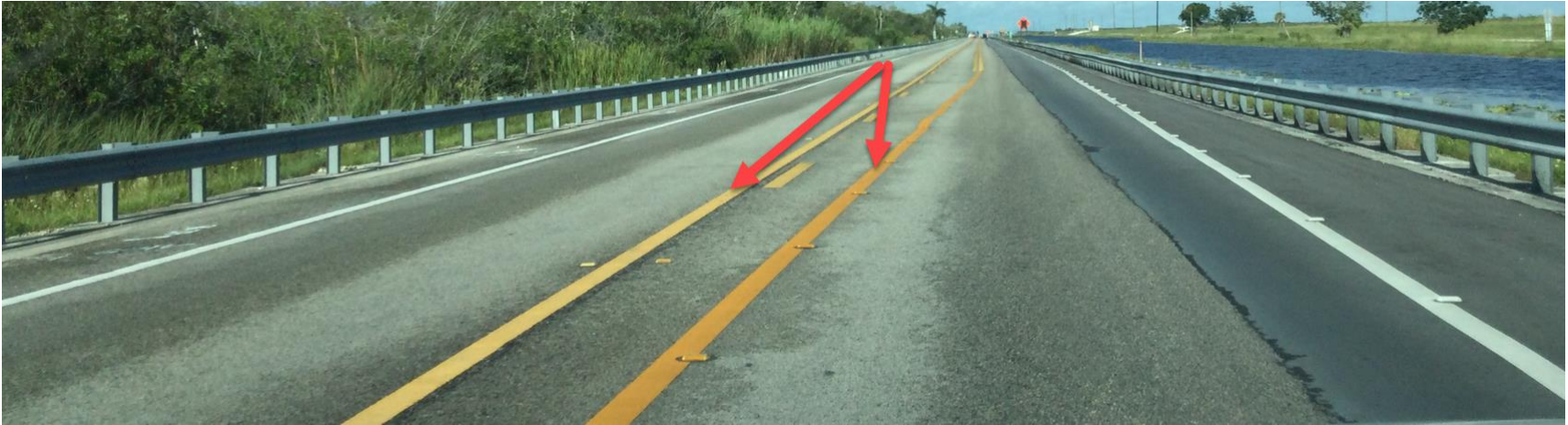

One area of the project had conflicting pavement markings. Index 102-600, Sheet 8 requires the removal of existing pavement markings that conflict with temporary work zone delineation when work exceeds one daylight period.

Process Review Findings

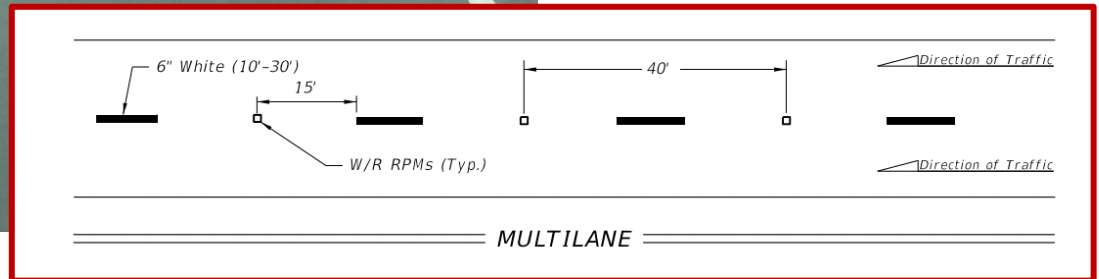

RPMs were misaligned with temporary striping in several areas. Index 706-001 requires RPMs to be placed in line with the stripe (see screenshot above).

Process Review Findings

One location had conflicting pavement markings. Index 102-600, Sheet 8 requires the removal of existing pavement markings that conflict with temporary work zone delineation when work exceeds one daylight period.



Process Review Findings

Why is device and pavement marking quality so important?

Let's look at that picture of the RPMs again...



Process Review Findings

Why is device and pavement marking quality so important?

What is being seen?



Process Review Findings

Pedestrian walkway was not properly detoured. Index 102-660 requires pedestrian LCDs be placed across the full width of the closed sidewalk. In addition, Design Standards, Index 102-660 and ADA Guidelines require all temporary walkway surfaces be accessible with firm, stable, slip resistant and kept free of obstructions.



Process Review Findings



Pedestrian walkway was not properly detoured and Ped LCDs were not properly maintained.

Index 102-660 and ADA Guidelines require all temporary walkway surfaces be accessible with firm, stable, slip resistant and kept free of obstructions. Spec 102-9.5.2 also requires joints between Ped LCDs must a maximum offset of 1/2 inch in any one plane.

Process Review Findings



Type II barricades with signs attached used to close sidewalks and curb ramps did not have detectable warnings. Index 102-660 requires pedestrian LCDs be placed across the full width of closed sidewalks and requires curb ramps to have detectable warnings.

Process Review Findings



Type K barrier contained significant cracks throughout the cross section and large spalls with exposed rebar. Spec 102-9.1 requires all temporary concrete barrier to meet acceptable standards as outlined in the Department's Temporary Concrete Barrier Evaluation Guide.

Process Review Findings

Bolts were protruding from the tracking face of one unit of barrier wall presenting a snag hazard.

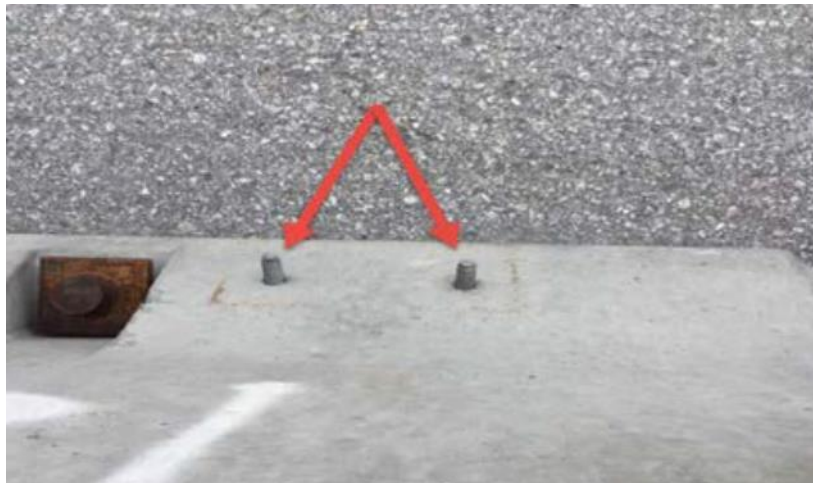

The bolts have been cut off flush with the wall.



Department's Temporary Concrete Barrier Evaluation Guide require there to be no snag hazards.

Process Review Findings



Construction debris, stockpiled material and other objects within deflection space of Type K barrier. Index 102-100, Sheet 1 requires the deflection space to be clear of any grass, construction debris, stockpiled materials, equipment and objects.

Process Review Findings



Low profile barrier did not have proper flare rate on approach end. Index 102-120 requires a 6 foot offset from front face of barrier to tangent extension (see screenshot below)].

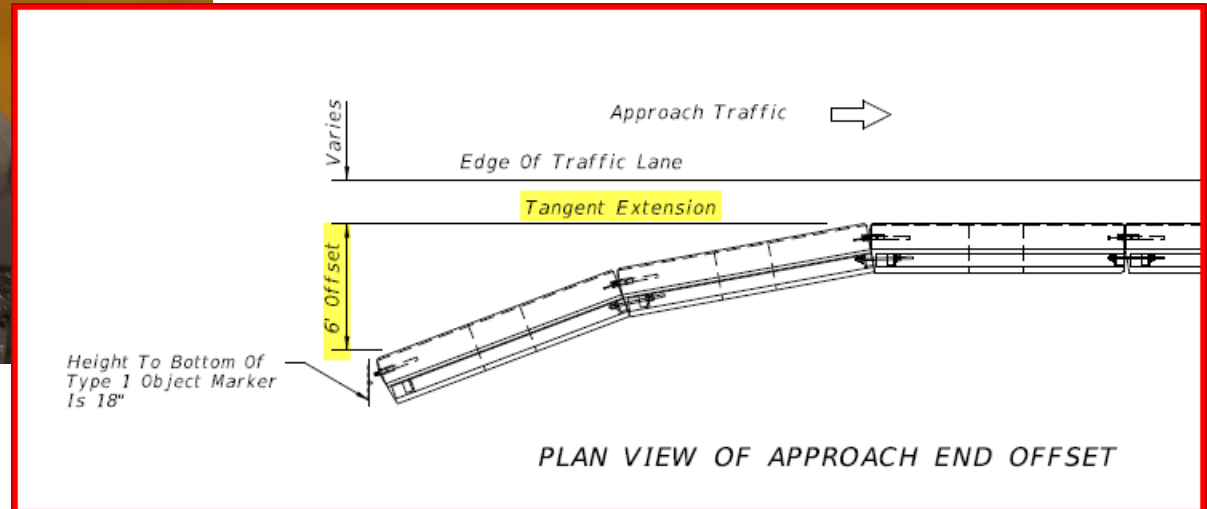

Process Review Findings

Low profile barrier did not have asphalt pad extend throughout the deflection space behind barrier.

Index 102-120 requires 9 inches of deflection space behind barrier.



WORK ZONE SPEED	OFFSET TO TRAVELWAY	DEFLECTION SPACE
45 MPH OR LESS	1' MIN, 2' PREFERRED	9"

Process Review Findings



Crash cushion bracket support for the transition panel was missing. Vendor drawings require bracket support for transition panels (see screenshot below).

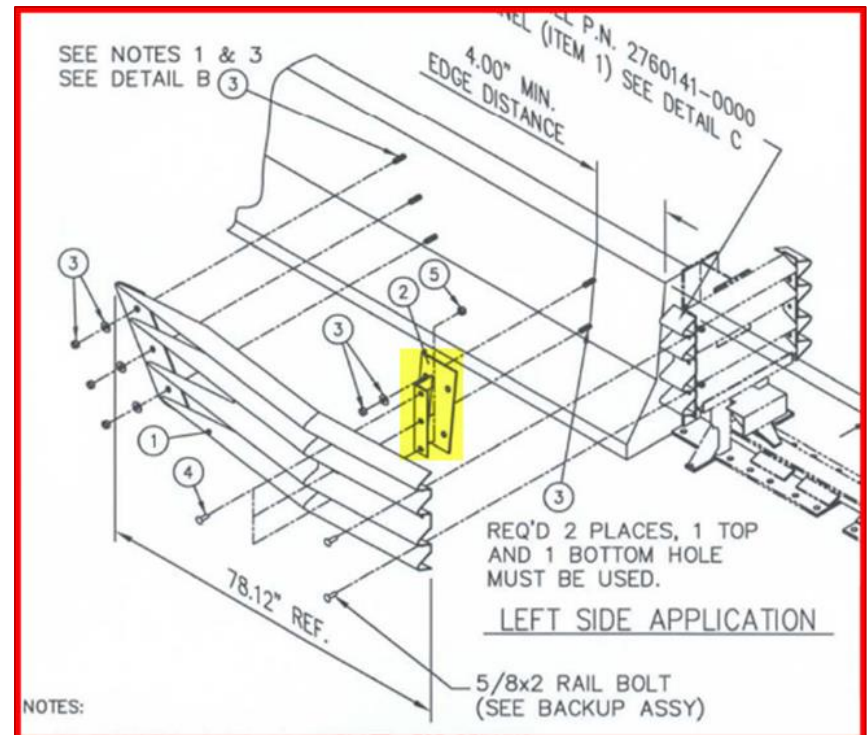

Process Review Findings



TRACC crash cushion had several loose nuts. Manufacturer's vendor drawings require all nuts be snug tight.



Process Review Findings

Quadguard II crash cushion installed without a shim kit.

Manufacturer's vendor drawings requires a shim kit, diaphragm, and rail guide.

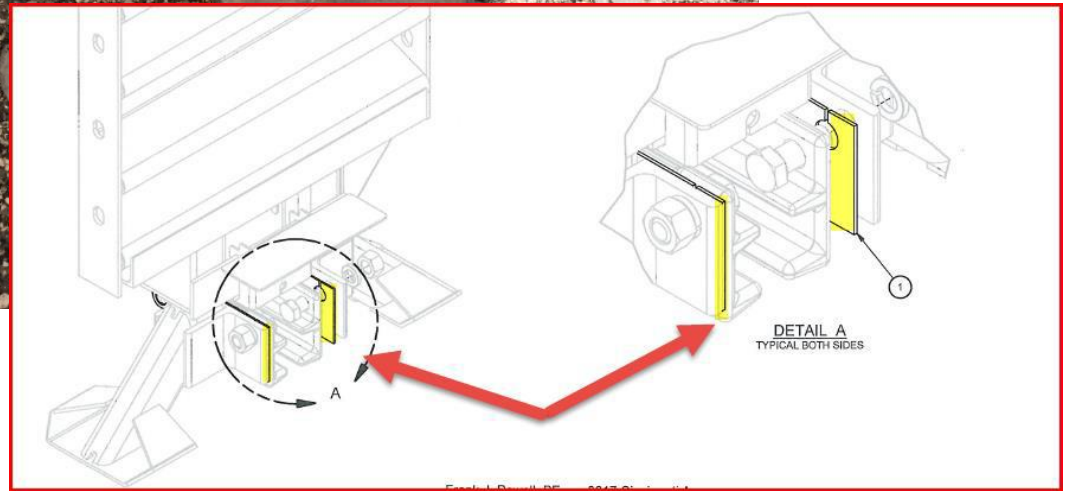
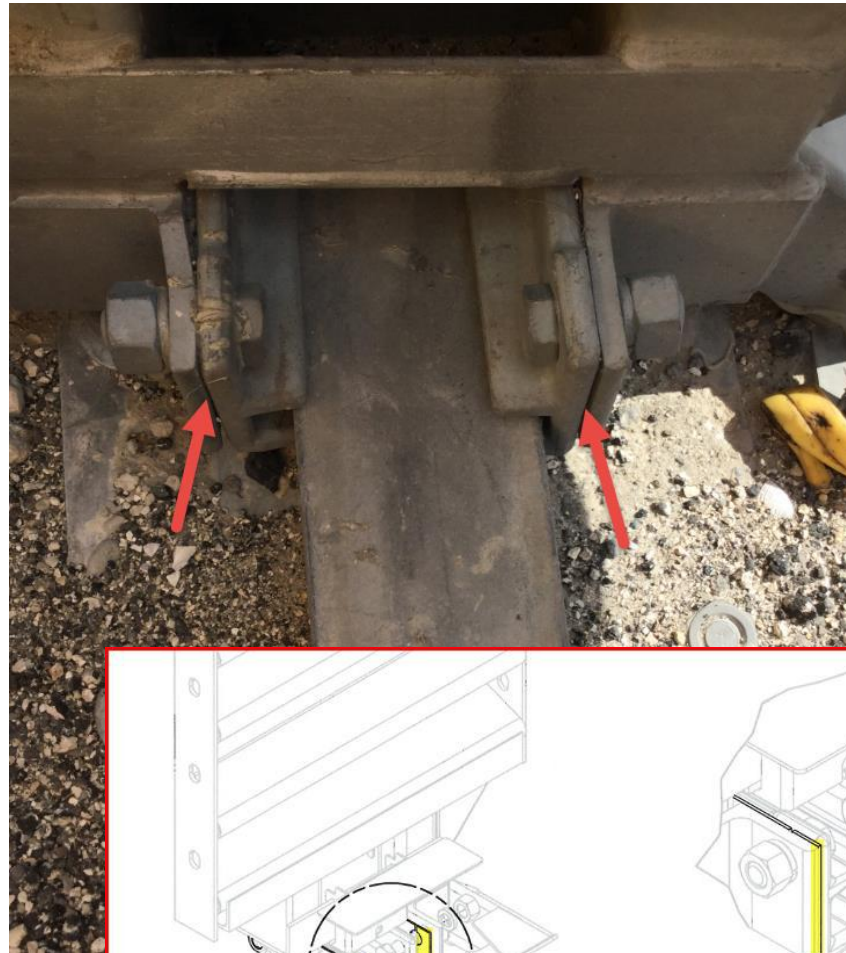

Process Review Findings

Anchor was installed on the backside of the barrier abutting crash cushion.

Index 102-110 requires anchors to be installed on traffic side.



Process Review Findings



Crash cushions missing APL number. Spec 102-9.1 requires the APL number to be permanently marked on all TTC devices at a readily visible location.

Process Review Findings

Guardrail was missing end treatment. Index 536-001 requires the use of a trailing anchorage to obtain proper ribbon strength.



Additional Resources

- ATSSA Quality Guidelines
<http://www.atssa.com/cvweb/cgi-bin/msascartdll.dll/ProductInfo?productcd=QS>
- MUTCD
https://mutcd.fhwa.dot.gov/kno_2009r1r2.htm
- Utility Accommodation Manual
<http://www.fdot.gov/programmanagement/utilities/UAM.shtm>
- CPAM
<http://www.fdot.gov/construction/manuals/cpam/CPAMManual.shtm>
- Construction MOT Website
<http://www.fdot.gov/construction/Engineers/MOT/MOTMain.shtm>

Questions



Olivia Townsend 850-414-4303

Olivia.Townsend@dot.state.fl.us