

FDOT UTILITY RELOCATION SCHEDULE MANUAL

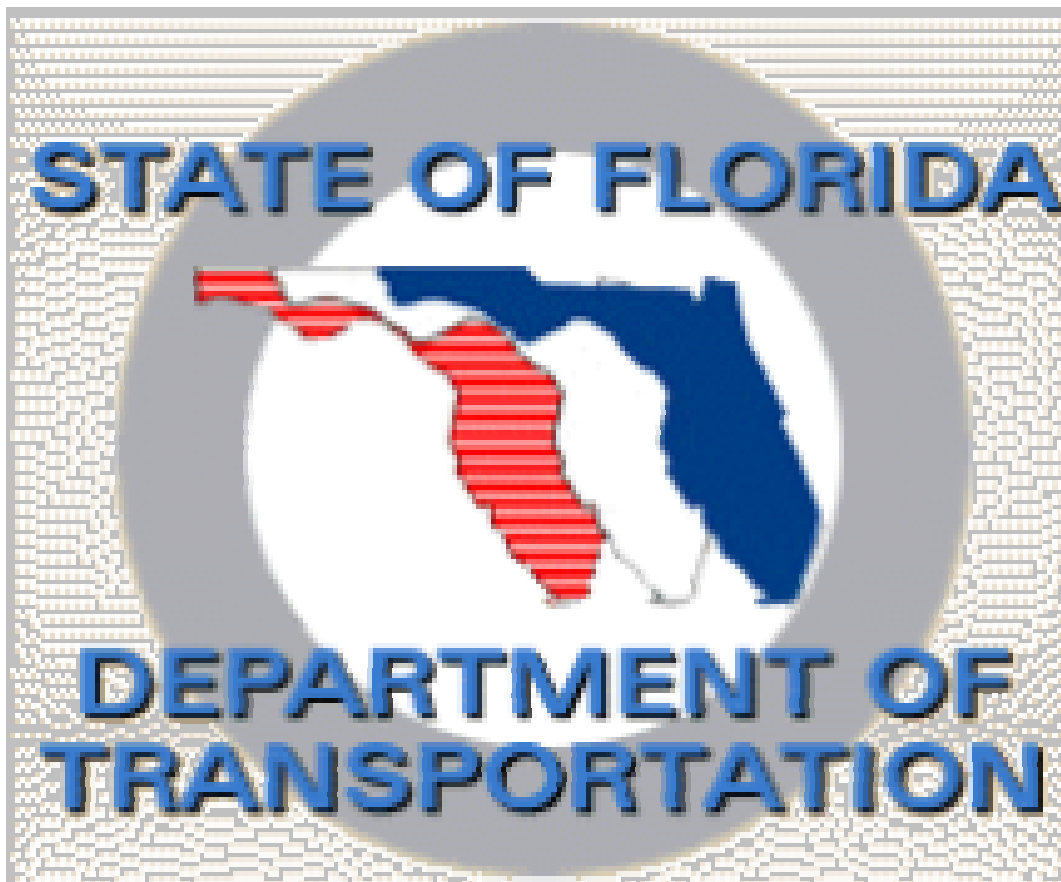

June 12th, 2001

FDOT UTILITY RELOCATION SCHEDULE MANUAL

Dr. Ralph D. Ellis Jr., P.E. Principal Investigator
relli@ce.ufl.edu

Jennifer W. Shannon, E.I. Research Assistant
Michael Shane Johnson Research Assistant
Benjamin S. Yang, E.I. Research Assistant
Barry D. Guertin, E.I. Research Assistant

Department of Civil & Coastal Engineering
College of Engineering
UNIVERSITY OF FLORIDA
Gainesville

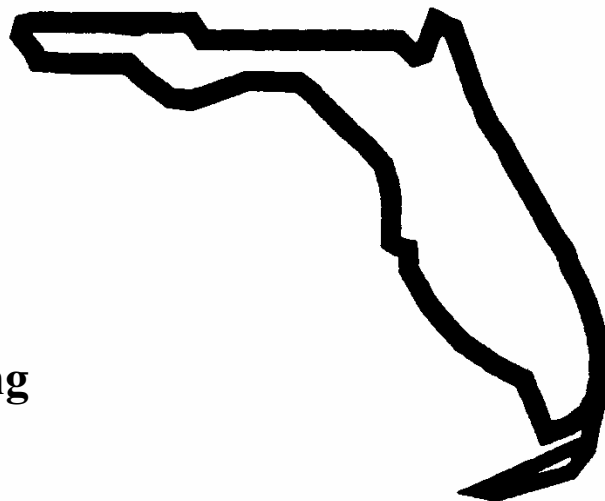

INTRODUCTION

The researchers at the University of Florida would like to thank John Shriner of the Florida Department of Transportation for allowing them to work on this project. It is hoped that this manual will be a helpful guide to professionals who are interested in the duration of utility relocation and installation operations. Although this manual is not the final word in utilities scheduling it is hoped that you will find it useful and that it will provide you with a better understanding of the time requirements for utilities operations.

Respectfully:

Ralph D. Ellis Jr. P.E.
Jennifer W. Shannon, E.I.
Michael Shane Johnson
Benjamin Yang, E.I.
Barry D. Guertin, E.I.

BACKGROUND

FDOT scheduling engineers need a reliable reference for estimating the duration of different utility relocations encountered on FDOT construction projects. The type of utility work involved on a project may vary considerably. FDOT projects can involve everything from fiber optic systems to conventional storm drainage, often with many different utility systems involved in a single project. This manual is intended to be the beginning of a comprehensive information base for estimating utility production rates and activity duration.

The University of Florida was under contract with the FDOT to create this Utility Production Rate Scheduling Reference for FDOT Construction Projects. The research team used the following research approach:

- Approached members of the utility industry to develop a list of common utility activities.
- Developed list of common utility activities from FDOT utility relocation schedules
- Verified the list of common utility activities with FDOT district utility engineers
- Obtained low, average, and high durations and influencing factors for items on the list of common utility activities from different utility companies and means manuals
- Compared the information from the utility companies with the data from the utility relocation schedules and means manuals

For more information on the research process, please see the document [Development of a Utility Production Rate Scheduling Reference for FDOT Construction Projects](#).

This estimating reference presents production rates for utility work activities within the context of FDOT projects. The range of times and influencing factors for the activities can serve as adjustment factors for a scheduling engineer. However, anyone who uses this manual must note that the durations for the activities included in this manual are ***on-site construction times only!*** The time necessary to acquire permits and to design a utility relocation is not included in this manual. The focus of this research was to find construction times and that is what is included in this manual.

Table of Contents

CABLE	1
Activity CA01 Adjust or replace one fiber optic aerial cable.....	1
Activity CA02 Place and pull new coaxial cable through a four-inch duct.....	1
Activity CA03 Splice and activate new coaxial cable.....	1
Activity CA04 Directional bore 100 feet for a four-inch duct.....	2
Activity CA05 Relocate three fiber overhead cables to new poles.....	2
Activity CA06 Remove one existing underground amplifier and power supply.....	2
Activity CA07 Remove existing overhead cable per 100-feet.....	3
Activity CA08 Remove existing cable crossing per span.....	3
ELECTRIC	4
Activity OE01 Relocate per span one 13kV line.....	4
Activity OE02 Relocate one pole for 12.47 kV line.....	4
Activity OE03 Remove one overhead electric crossing for a 13.2 kV line.....	5
ActivityOE04 Remove fifty feet of aerial cable.....	5
ActivityOE05 Provide service for street light load center (480 V).....	5
Activity OE06 Remove poles for an aerial crossing.....	6
Activity OE07 Provide service for traffic signal (120 V).....	6
Activity UE01 Remove three buried cables per fifty feet.....	6
Activity UE02 Place duct bank X by Y of Z-inch conduit per fifty feet.....	7
ActivityUE03 Remove 3-100 mm conduits for fifty feet.....	7
Activity UE04 Adjust existing electric conduits.....	8
ActivityUE05 Place pre-cast manhole.....	8
GAS.....	9
Activity GA01 Protect and support ten linear feet of one low-pressure gas line.....	9
Activity GA02 Adjust one two-inch steel pipe.....	9
Activity GA03 Lower one ¾” service line in place.....	9
Activity GA04 Install one new two-inch gas line per fifty linear feet.....	10
Activity GA05 Install one bottom-out connection for one four-inch gas main.....	10
Activity GA06 Place out of service one four-inch gas line per fifty linear feet.....	10
Activity GA07 Lower one high-pressure gas line.....	11
Activity GA08 Encase one high-pressure gas line.....	11
PHONE	12
Activity PA01 Install and splice 100 linear feet of buried copper cable.....	12
Activity PA02 Install and splice 100 linear feet of buried fiber cable.....	12
Activity PA03 Install and splice 100 linear feet of aerial copper cable.....	12
Activity PA04 Install and splice 100 linear feet of aerial fiber cable.....	13
Activity PA05 Install and splice 100 linear feet of copper cable in conduit.....	13
Activity PA06 Install and splice 100 linear feet of fiber cable in conduit.....	13
Activity PA07 Place fifty feet of X-pair cable out of service.....	14
Activity PA08 Place (1) 4” sched. 40 PVC conduit out of service.....	14
Activity PA09 Place (1) 4” sched. 40 PVC conduit in service.....	15
Activity PA10 Lower fifty linear feet of X-pair cable.....	15
Activity PA11 Install and connect one handhole and duct system.....	15
Activity PA12 Adjust one telephone handhole to final grade.....	16
Activity PA13 Adjust frame and cover for one manhole.....	16

Activity PA14 Splice one 900-pair cable.....	16
SEWER.....	17
Activity SA01 Furnish, install, and connect fifty linear feet of X-inch PVC SDR.....	17
Activity SA02 Furnish, install, and connect fifty linear feet of X-inch PVC FM.....	17
Activity SA03 Remove and replace fifty linear feet of X-inch PVC FM.....	18
Activity SA04 Plug and place out of service one eight-inch sanitary sewer main.....	18
Activity SA05 Re-route fifty linear feet of X-inch PVC FM.....	19
Activity SA06 Grout fill one X-inch sanitary sewer lateral for fifty linear feet.....	19
Activity SA07 Furnish and install one manhole.....	20
Activity SA08 Adjust ring and cover to grade for one manhole.....	20
WATER.....	21
Activity WA01 Furnish, install, and connect fifty linear feet of Type K copper pipe.....	21
ActivityWA02 Cut and plug one X-inch pipe.....	21
Activity WA03 Adjust one water valve box to grade.....	22
Activity WA04 Adjust one X-inch WM.....	22
Activity WA05 Remove and replace fifty linear feet of X-inch WM.....	23
ActivityWA06 Furnish and install one fire hydrant assembly.....	23
Activity WA07 Remove and replace one fire hydrant assembly.....	24
Activity WA08 Remove and replace one water meter.....	24
Activity WA09 Relocate one water meter.....	25

Adjustment or replacement one fiber optic aerial cable.

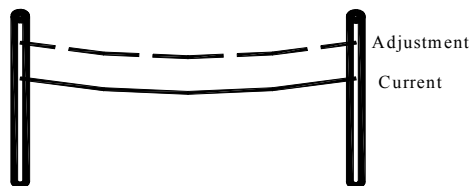

Activity CA01 Adjust or replace one fiber optic aerial cable.

Lowest Duration: 4 hours
Average Duration: 5 hours
Highest Duration: 6 hours

Influencing Factors:

- type of pole
- energized or de-energized cable
- drilling time

Place & pull new coax cable through 4" conduit

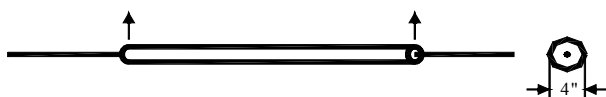

Activity CA02 Place and pull new coaxial cable through a four-inch duct.

Lowest Duration: 5 days
Average Duration: 6 days
Highest Duration: 10 days

Influencing Factors:

- Soil conditions
- Location of other utilities

Splice & activate new coax cable



Activity CA03 Splice and activate new coaxial cable.

Lowest Duration: 5 days
Average Duration: 6 days
Highest Duration: 10 days

Influencing Factors:

- Location of coaxial cable
- Location of other utilities
- Number of people on crew
- Available equipment



**Activity CA04 Directional bore
100 feet for a four-inch duct.**

Lowest Duration: 1 day
Average Duration: 2 days
Highest Duration: 4 days

Influencing Factors:

- Soil conditions
- Known or unknown utility locations
- Any failed attempts for a successful directional bore

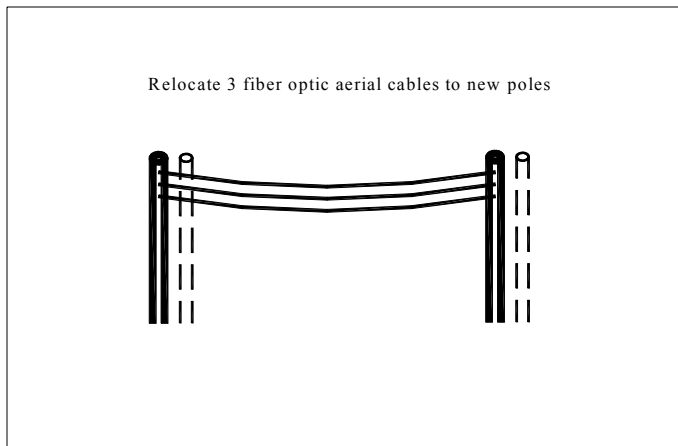

**Activity CA05 Relocate three fiber
overhead cables to new poles.**

Lowest Duration: 6 hours
Average Duration: 12 hours
Highest Duration: 18 hours

Influencing Factors:

- Type of pole
- Number of attachments per pole
- Energized or de-energized cable

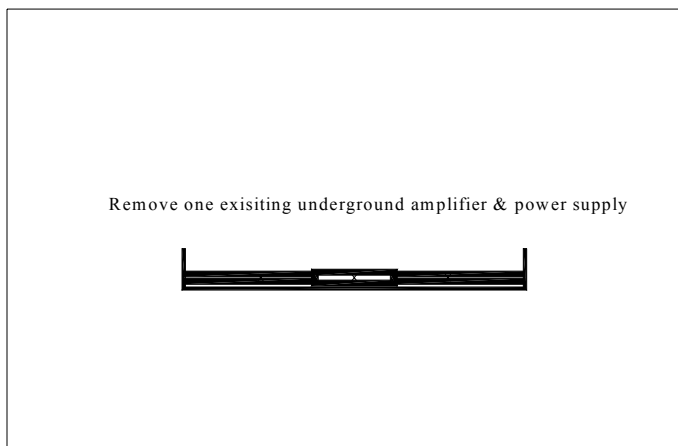

**Activity CA06 Remove one
existing underground amplifier
and power supply.**

Lowest Duration: NA
Average Duration: 1 day
Highest Duration: NA

Influencing Factors:

- Soil conditions
- Location of other utilities

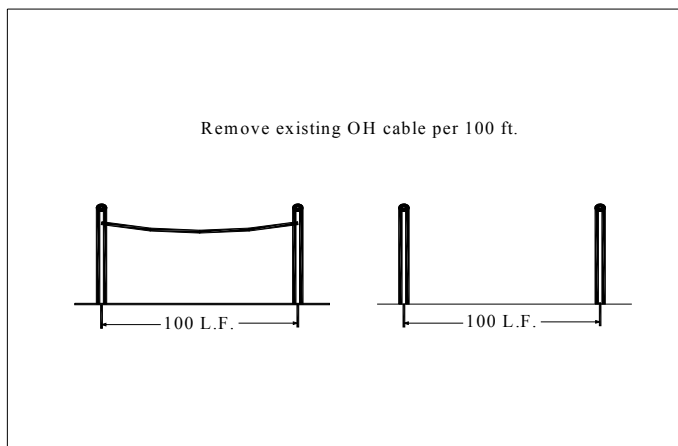

Activity CA07 Remove existing overhead cable per 100-feet.

Lowest Duration: 0.4 hours
Average Duration: 0.5 hours
Highest Duration: 0.7 hours

Influencing Factors:

- Traffic
- Energized or de-energized cable
- Location of other utilities
- Street crossings

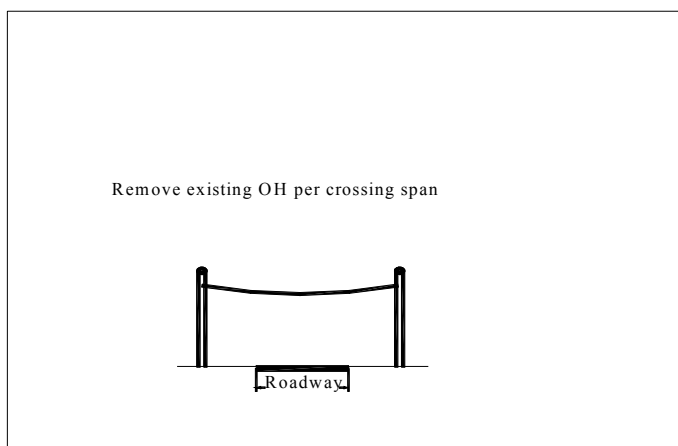

Activity CA08 Remove existing cable crossing per span.

Lowest Duration: 0.8 hours
Average Duration: 1.0 hour
Highest Duration: 1.4 hours

Influencing Factors:

- Traffic
- Energized or de-energized cable
- Location of other utilities
- Street crossings

ELECTRIC

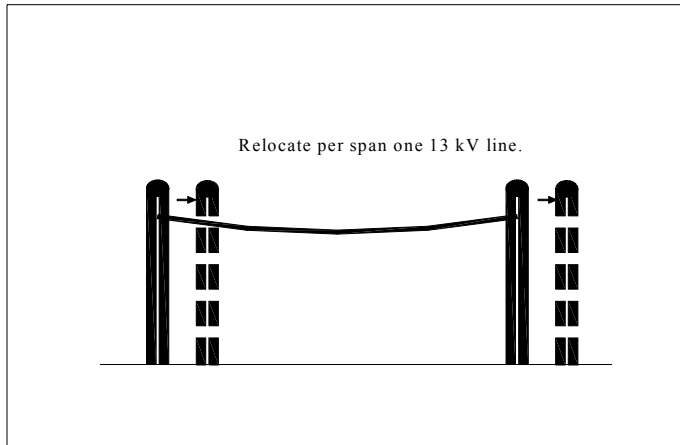

Activity OE01 Relocate per span one 13kV line.

Lowest Duration: 0.5 days

Average Duration: 1 day

Highest Duration: 10 days

Influencing Factors:

- Crew availability
- Truck access
- Type of pole
- Pole mounted equipment
- Outage coordination required
- MOT coordination



Activity OE02 Relocate one pole for 12.47 kV line.

Lowest Duration: 0.5 days

Average Duration: 2 days

Highest Duration: 5 days

Influencing Factors:

- Crew availability
- Truck access
- Type of pole
- Pole mounted equipment
- Outage coordination required
- MOT coordination

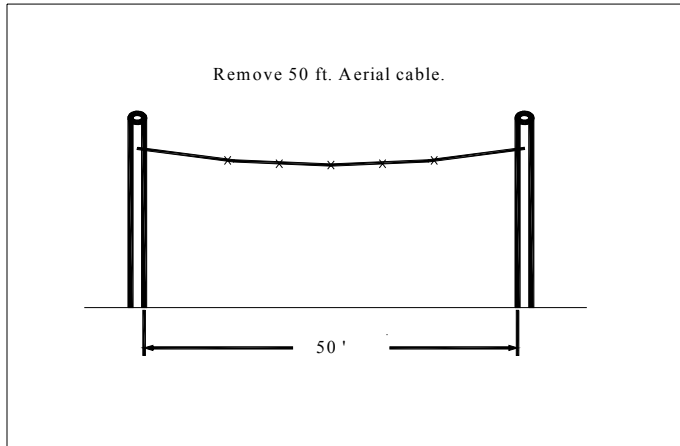

Activity OE03 Remove one overhead electric crossing for a 13.2 kV line.

Lowest Duration: 1 day
Average Duration: 2 days
Highest Duration: 4 days

Influencing Factors:

- Crew availability
- Truck access
- Type of pole
- Pole mounted equipment
- Outage coordination required
- MOT coordination

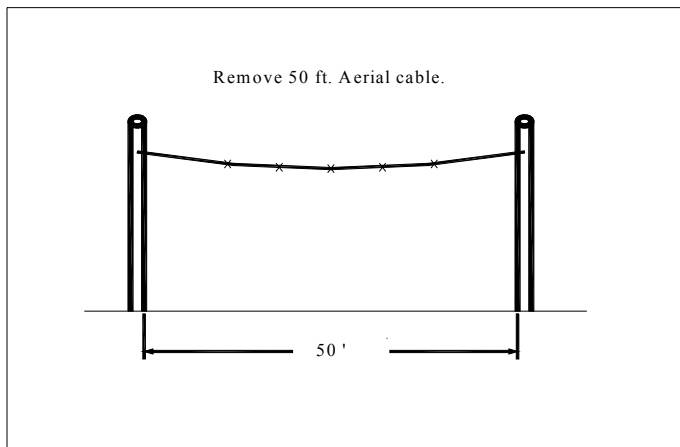

ActivityOE04 Remove fifty feet of aerial cable.

Lowest Duration: 0.5 days
Average Duration: 1 day
Highest Duration: 2 days

Influencing Factors:

- Crew availability
- Truck access
- Outage coordination required
- MOT coordination

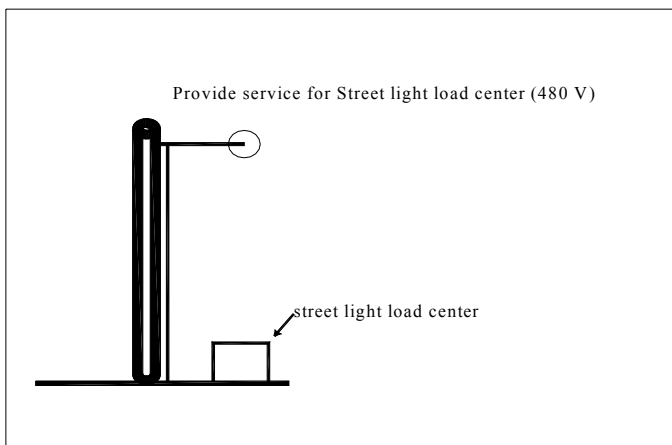

Activity OE05 Provide service for street light load center (480 V).

Lowest Duration: 1 day
Average Duration: 3 days
Highest Duration: 10 days

Influencing Factors:

- Crew availability
- Truck access
- Type of line work required
- MOT coordination

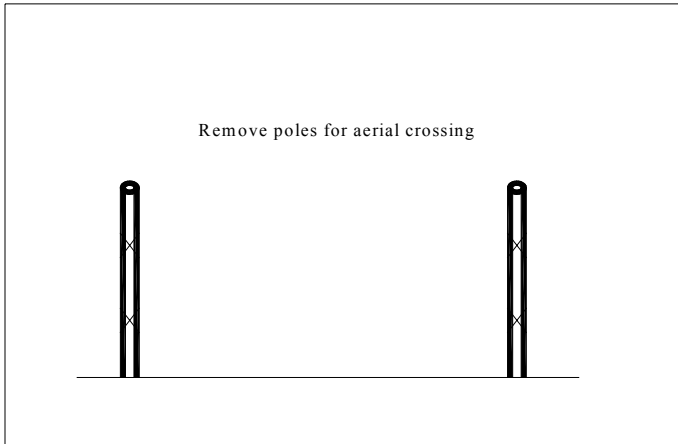

Activity OE06 Remove poles for an aerial crossing.

Lowest Duration: 1 day
Average Duration: 2 days
Highest Duration: 4 days

Influencing Factors:

- Crew availability
- Truck access
- MOT coordination
- Type of pole
- Disposal of pole

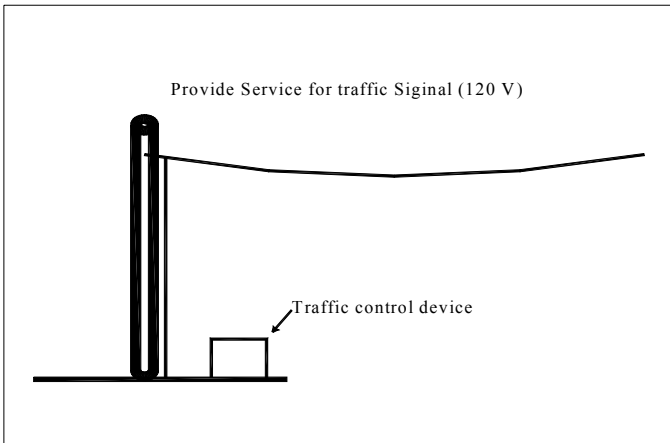

Activity OE07 Provide service for traffic signal (120 V).

Lowest Duration: 1 day
Average Duration: 3 days
Highest Duration: 10 days

Influencing Factors:

- Crew availability
- Truck access
- Line work required
- MOT coordination

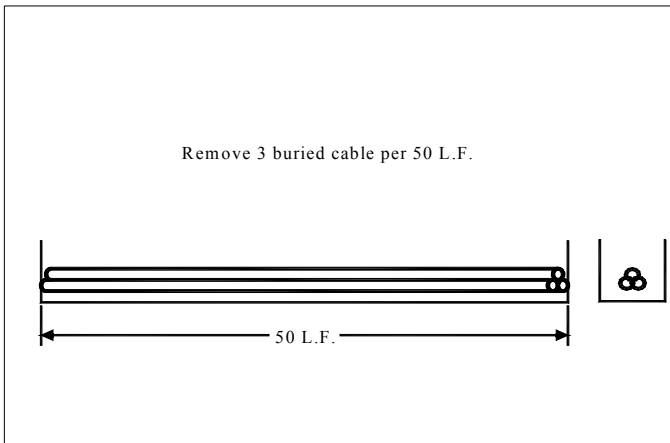

Activity UE01 Remove three buried cables per fifty feet.

Lowest Duration: 1 day
Average Duration: 2 days
Highest Duration: 5 days

Influencing Factors:

- Crew availability
- Site conditions
- Ground water level
- Quality of soil
- Outage or MOT coordination required

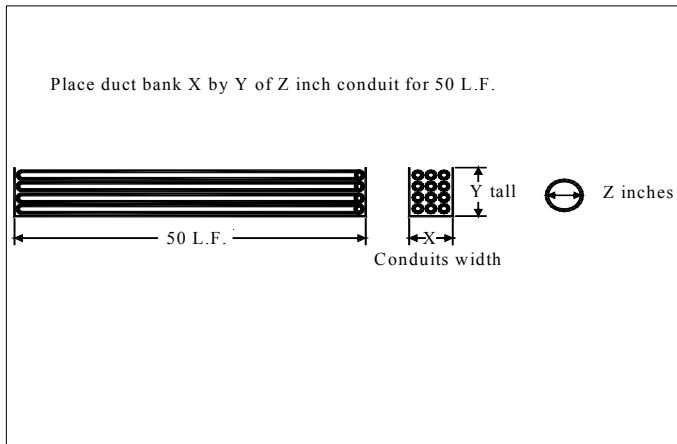

Activity UE02 Place duct bank X by Y of Z-inch conduit per fifty feet.

Lowest Duration: 1 day
Average Duration: 2 days
Highest Duration: 5 days

Influencing Factors:

- Crew availability
- Site conditions
- Ground water level
- Quality of soil
- Outage or MOT coordination required

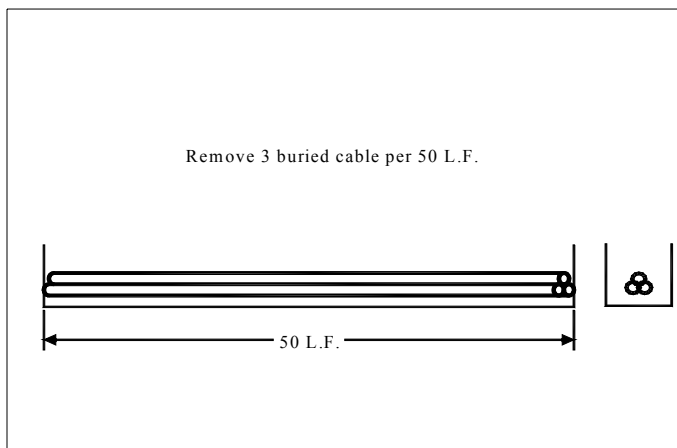

Activity UE03 Remove 3-100 mm conduits for fifty feet.

Lowest Duration: 1 day
Average Duration: 2 days
Highest Duration: 5 days

Influencing Factors:

- Crew availability
- Site conditions
- Ground water level
- Quality of soil
- Outage or MOT coordination required

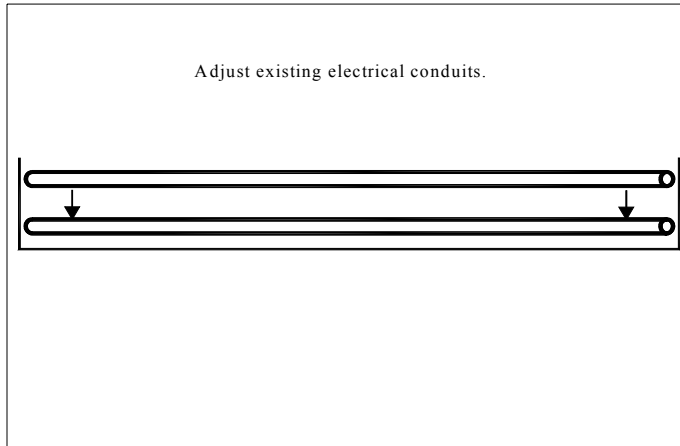

Activity UE04 Adjust existing electric conduits.

Lowest Duration: 1 day
Average Duration: 2 days
Highest Duration: 5 days

Influencing Factors:

- Crew availability
- Site conditions
- Ground water level
- Quality of soil
- Outage or MOT coordination required
- Ability to switch cable

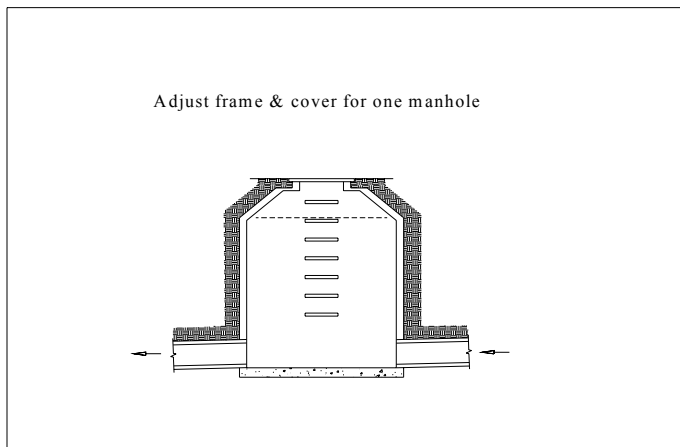

Activity UE05 Place pre-cast manhole.

Lowest Duration: 2 days
Average Duration: 5 days
Highest Duration: 10 days

Influencing Factors:

- Crew availability
- Site conditions
- Ground water level
- Quality of soil
- Outage or MOT coordination required
- Location of manhole
- Number of surrounding utilities
- Placement into pavement or grass

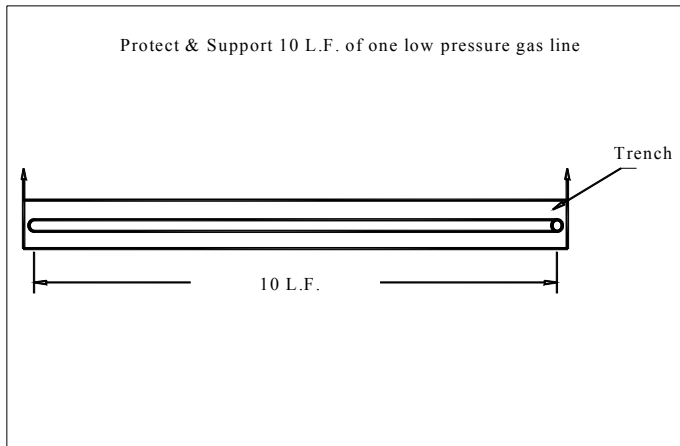

Activity GA01 Protect and support ten linear feet of one low-pressure gas line.

Lowest Duration: 0.5 days
 Average Duration: 1 day
 Highest Duration: 2 days

Influencing Factors:

- Open excavation
- Providing temporary support
- Site conditions
- Weather conditions
- Type of material
- Shoring equipment

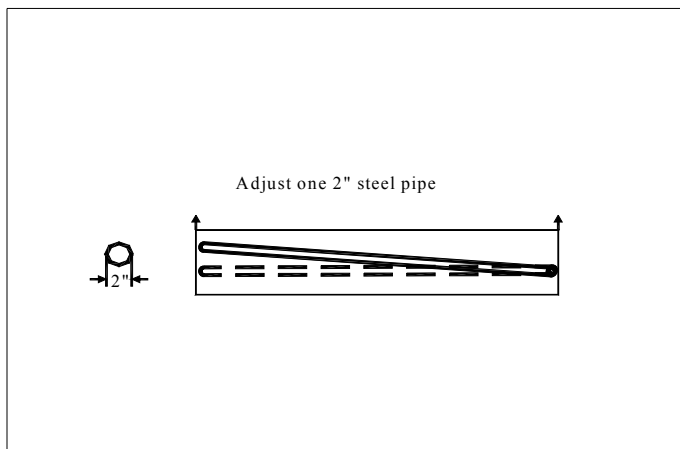

Activity GA02 Adjust one two-inch steel pipe.

Lowest Duration: 1 day
 Average Duration: 2 days
 Highest Duration: 4 days

Influencing Factors:

- Length to move
- Pressure
- Need to make stops and cuts in pipe

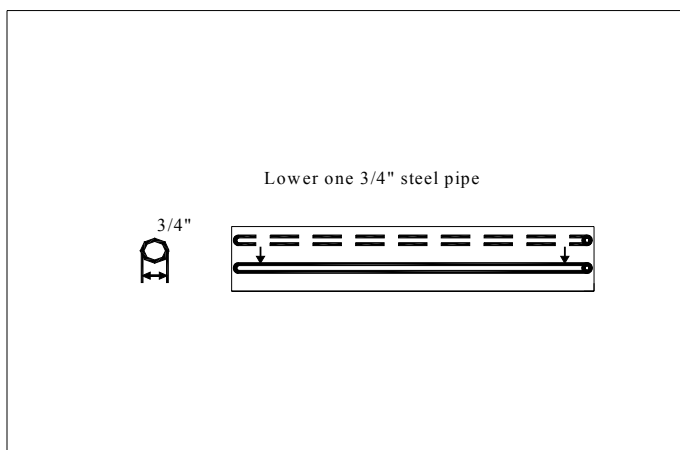

Activity GA03 Lower one 3/4" service line in place.

Lowest Duration: 1 day
 Average Duration: 1 day
 Highest Duration: 2 days

Influencing Factors:

- Site conditions
- Restoration of service
- Involvement of road crossing



Activity GA04 Install one new two-inch gas line per fifty linear feet.

Lowest Duration: 0.5 days
Average Duration: 1 day
Highest Duration: 2 days

Influencing Factors:

- Open trench
- Site conditions
- Type of pipe

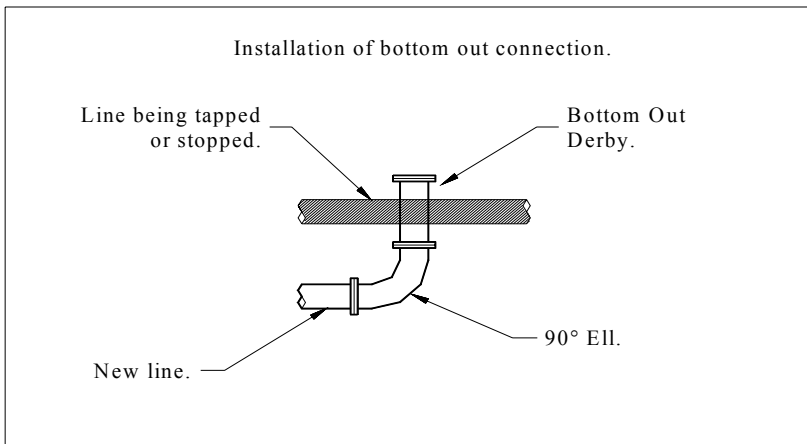

Activity GA05 Install one bottom-out connection for one four-inch gas main.

Lowest Duration: 0.5 days
Average Duration: 2 days
Highest Duration: 4 days

Influencing Factors:

- Site conditions
- Weather
- Welding
- Material and supplies

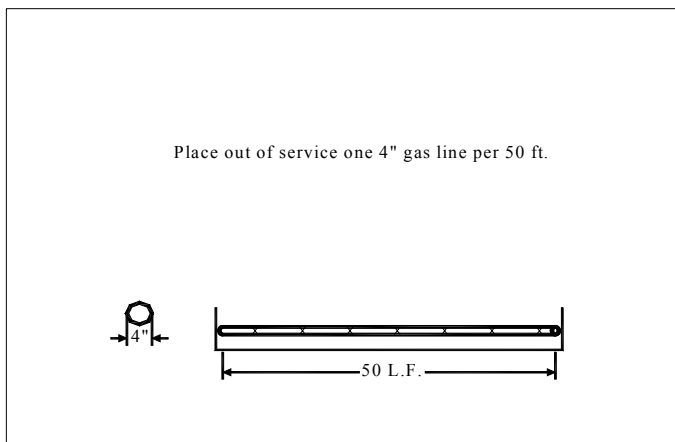

Activity GA06 Place out of service one four-inch gas line per fifty linear feet.

Lowest Duration: 0.5 days
Average Duration: 2 days
Highest Duration: 4 days

Influencing Factors:

- Length of main to purge
- Type of material for main
- Involvement of customers
- Installation of stoppers on each end

Lower one high pressure gas line.

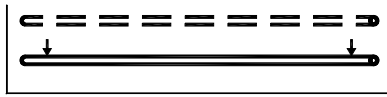

Activity GA07 Lower one high-pressure gas line.

Lowest Duration: 1 day
Average Duration: 3 days
Highest Duration: 6 days

Influencing Factors:

- Type of material for line
- Open excavation
- Location of other utilities

Encase one high-pressure gas line

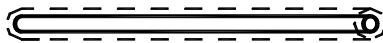

Activity GA08 Encase one high-pressure gas line.

Lowest Duration: 6 days
Average Duration: 8 days
Highest Duration: 10 days

Influencing Factors:

- Open excavation
- Installation of casing

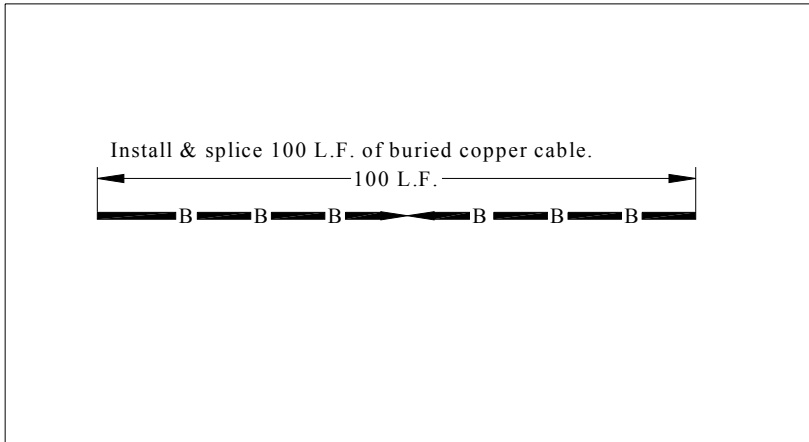

Activity PA01 Install and splice 100 linear feet of buried copper cable.

Lowest Duration: 2 days
Average Duration: 3 days
Highest Duration: 5 days

Influencing Factors:

- Special conduit cut-over
- Ground conditions



Activity PA02 Install and splice 100 linear feet of buried fiber cable.

Lowest Duration: 2 days
Average Duration: 3 days
Highest Duration: 5 days

Influencing Factors:

- Special conduit cut-over
- Ground conditions

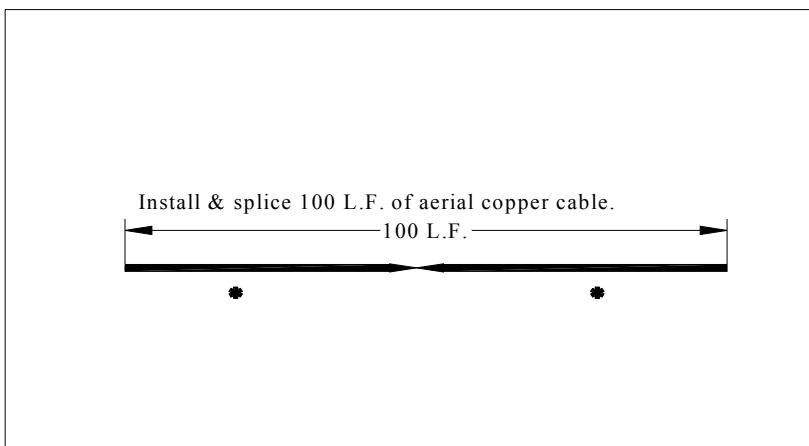

Activity PA03 Install and splice 100 linear feet of aerial copper cable.

Lowest Duration: 2 days
Average Duration: 3 days
Highest Duration: 5 days

Influencing Factors:

- Special conduit cut-over
- Ground conditions

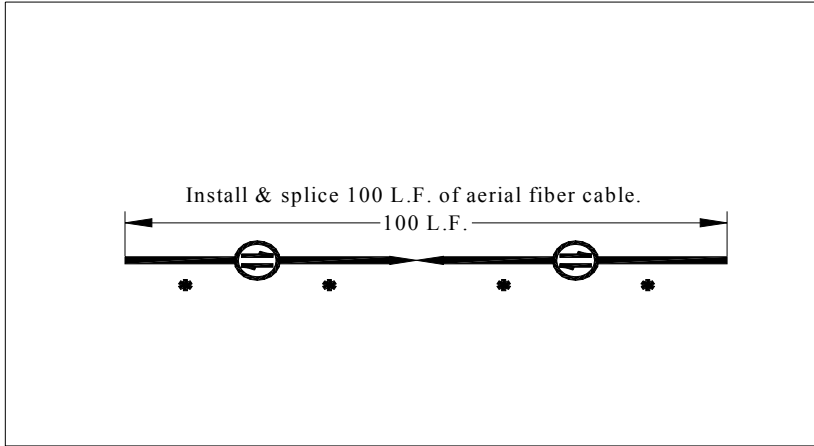

Activity PA04 Install and splice 100 linear feet of aerial fiber cable.

Lowest Duration: 2 days
Average Duration: 3 days
Highest Duration: 5 days

Influencing Factors:

- Special conduit cut-over
- Ground conditions

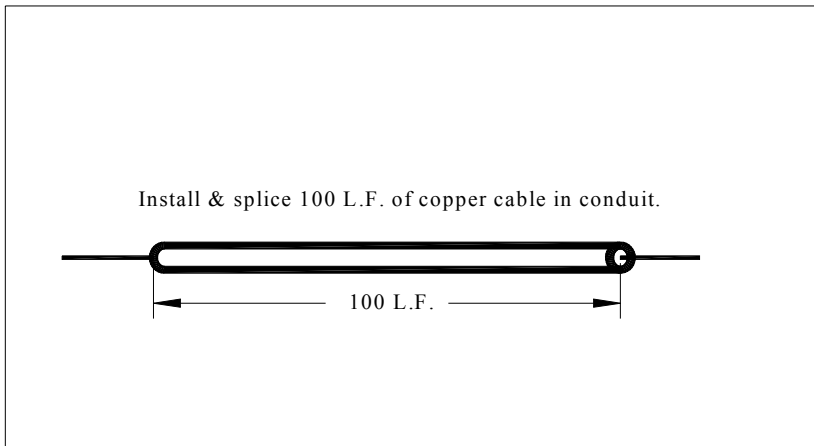

Activity PA05 Install and splice 100 linear feet of copper cable in conduit.

Lowest Duration: 2 days
Average Duration: 3 days
Highest Duration: 5 days

Influencing Factors:

- Special conduit cut-over
- Ground conditions
- Manhole access
- Traffic

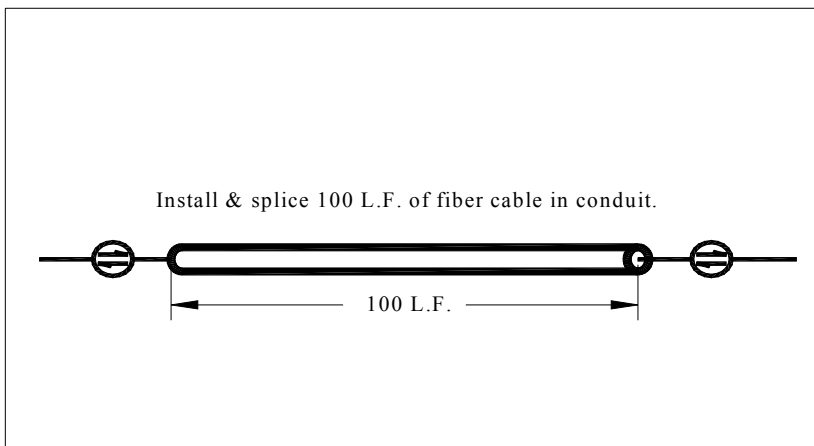

Activity PA06 Install and splice 100 linear feet of fiber cable in conduit.

Lowest Duration: 2 days
Average Duration: 3 days
Highest Duration: 5 days

Influencing Factors:

- Special conduit cut-over
- Ground conditions
- Manhole access
- Traffic

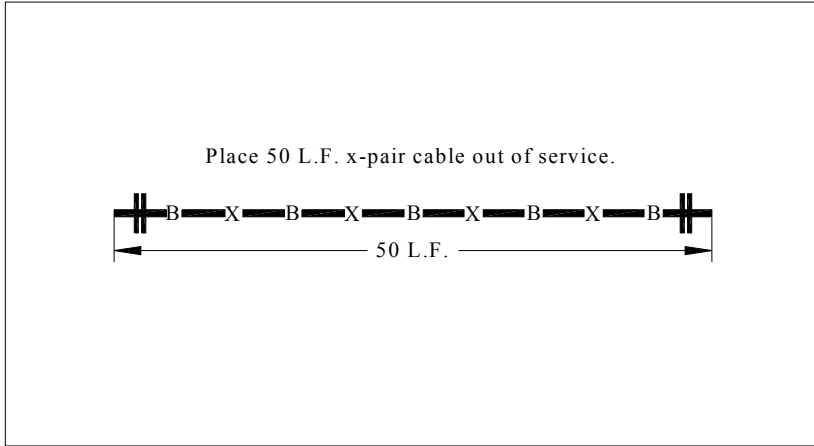

Activity PA07 Place fifty feet of X-pair cable out of service.

Lowest Duration: 2 days
Average Duration: 3 days
Highest Duration: 5 days

NOTE: The time for this activity is included in the splicing work.

Influencing Factors:

- Special conduit cut-over
- Ground conditions
- Manhole access
- Traffic

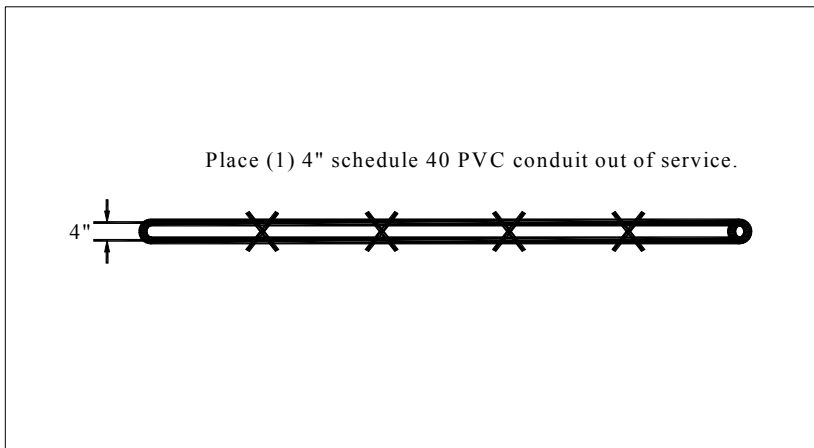

Activity PA08 Place (1) 4" sched. 40 PVC conduit out of service.

Lowest Duration: 2 days
Average Duration: 3 days
Highest Duration: 5 days

NOTE: The time for this activity is included in the splicing work.

Influencing Factors:

- Special conduit cut-over
- Ground conditions
- Manhole access
- Traffic

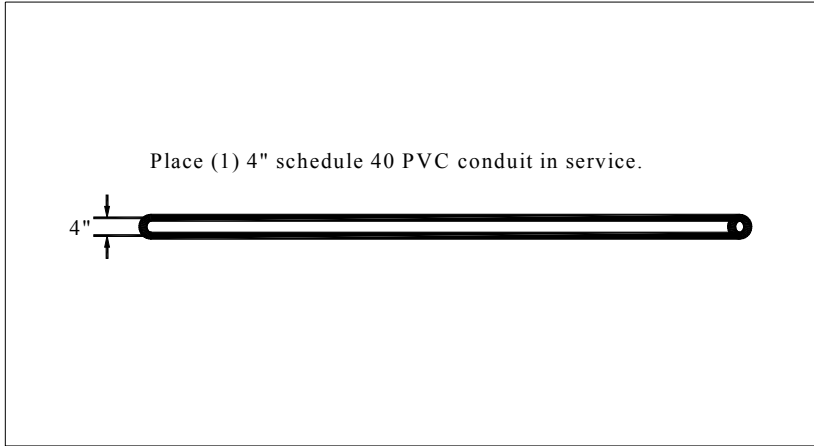

Activity PA09 Place (1) 4" sched. 40 PVC conduit in service.

Lowest Duration: 0.8 days
Average Duration: 1 day
Highest Duration: 1.2 days

Influencing Factors:

- Rocks

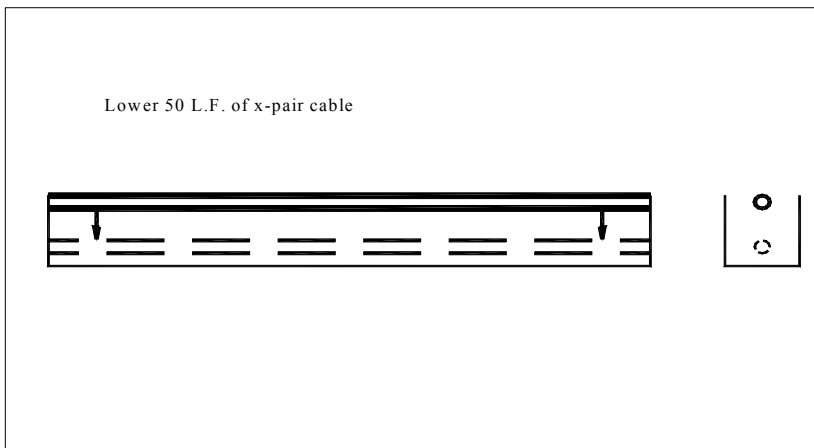

Activity PA10 Lower fifty linear feet of X-pair cable.

Lowest Duration: 1 day
Average Duration: 2 days
Highest Duration: 8 days

Influencing Factors:

- Rocks
- Must expose 150' of cable to lower 50'

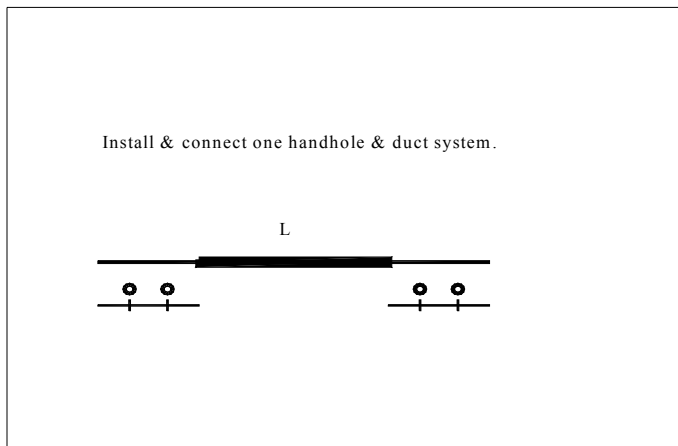

Activity PA11 Install and connect one handhole and duct system.

Lowest Duration: 2 days
Average Duration: 3 days
Highest Duration: NA

Influencing Factors:

- Availability of labor and equipment

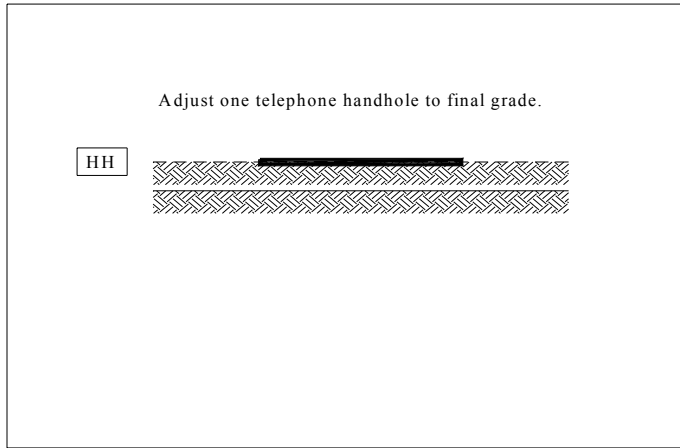

Activity PA12 Adjust one telephone handhole to final grade.

Lowest Duration: 0.5 days
 Average Duration: 1 day
 Highest Duration: 2 days

Influencing Factors:

- Need road surveyor to shoot grade

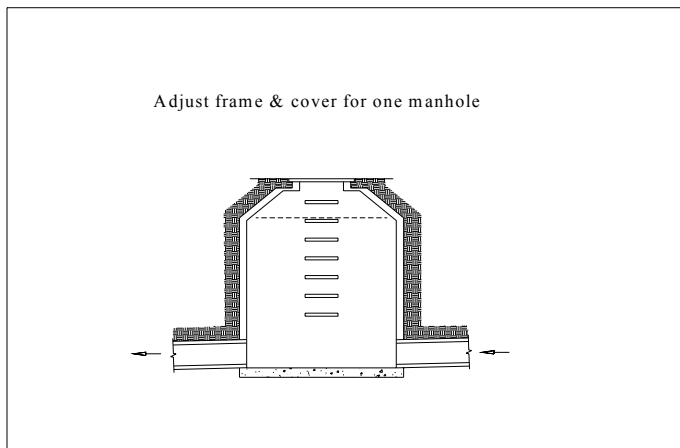

Activity PA13 Adjust frame and cover for one manhole.

Lowest Duration: 0.5 days
 Average Duration: 1 day
 Highest Duration: 2 days

Influencing Factors:

- Need road surveyor to shoot grade

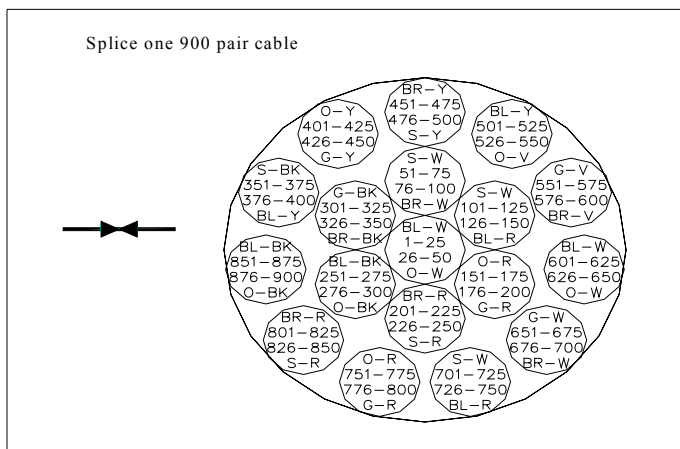

Activity PA14 Splice one 900-pair cable.

Lowest Duration: 2 days
 Average Duration: 3 days
 Highest Duration: 5 days

Influencing Factors:

- Need two people for this activity
- Special cut-over

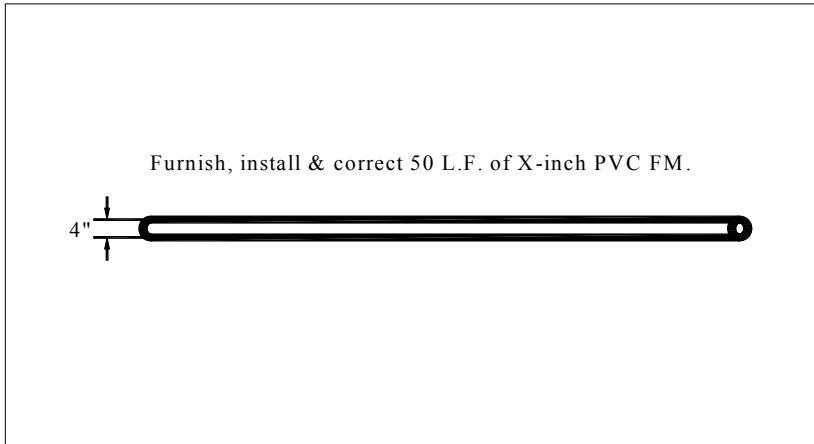

Activity SA01 Furnish, install, and connect fifty linear feet of X-inch PVC SDR.

Lowest Duration: 1 day
Average Duration: 14 days
Highest Duration: 20 days

Influencing Factors:

- Clearing and grubbing
- Ordering the material/Fabrication
- Availability of labor and equipment
- Soil conditions
- DOT permits
- Weather

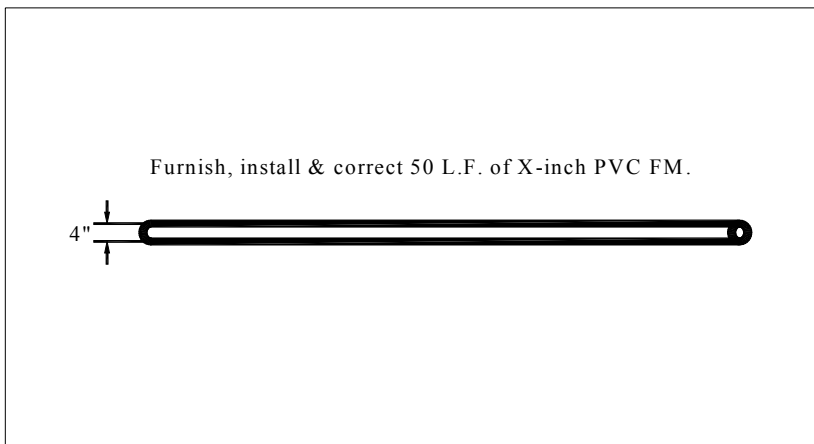

Activity SA02 Furnish, install, and connect fifty linear feet of X-inch PVC FM.

Lowest Duration: 1 day
Average Duration: 14 days
Highest Duration: 20 days

Influencing Factors:

- Clearing and grubbing
- Ordering the material/Fabrication
- Availability of labor and equipment
- Soil conditions
- DOT permits
- Weather

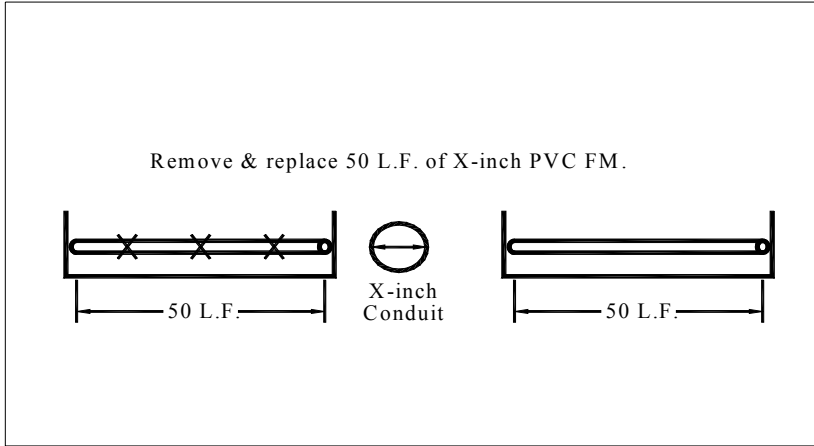

Activity SA03 Remove and replace fifty linear feet of X-inch PVC FM.

Lowest Duration: 3 days
Average Duration: 28 days
Highest Duration: 40 days

Influencing Factors:

- Clearing and grubbing
- Ordering the material/Fabrication
- Availability of labor and equipment
- Soil conditions
- DOT permits
- Weather
- Preparation of trench for new installation
- Disposal point for old materials
- Sometimes removal can take more time than installation

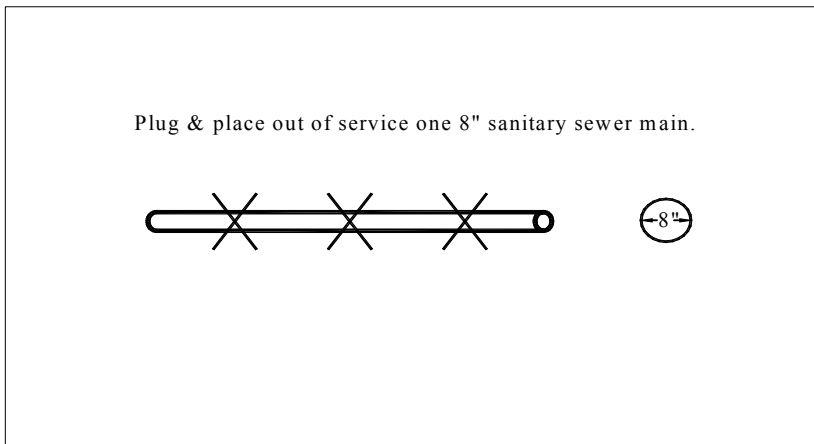

Activity SA04 Plug and place out of service one eight-inch sanitary sewer main.

Lowest Duration: 2 days
Average Duration: 4 days
Highest Duration: 30 days

Influencing Factors:

- Depth of pipe
- Soil conditions
- Permitting
- Weather
- Availability of labor and equipment

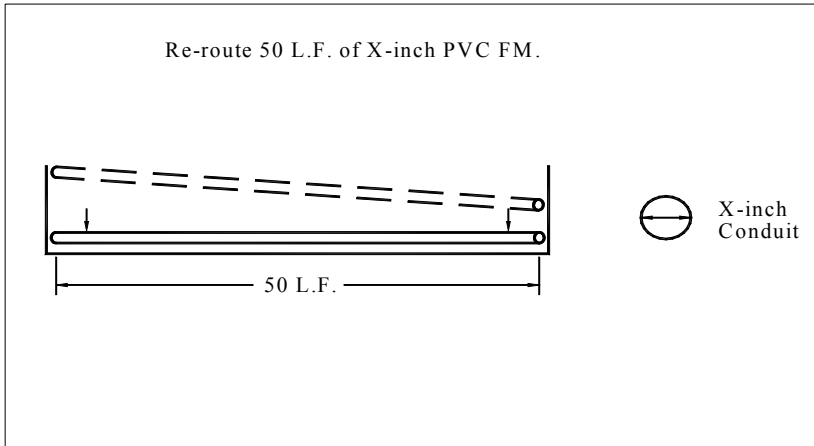

Activity SA05 Re-route fifty linear feet of X-inch PVC FM.

Lowest Duration: 1 day
Average Duration: 14 days
Highest Duration: 20 days

Influencing Factors:

- Clearing and grubbing
- Ordering the material/Fabrication
- Availability of labor and equipment
- Soil conditions
- DOT permits
- Weather

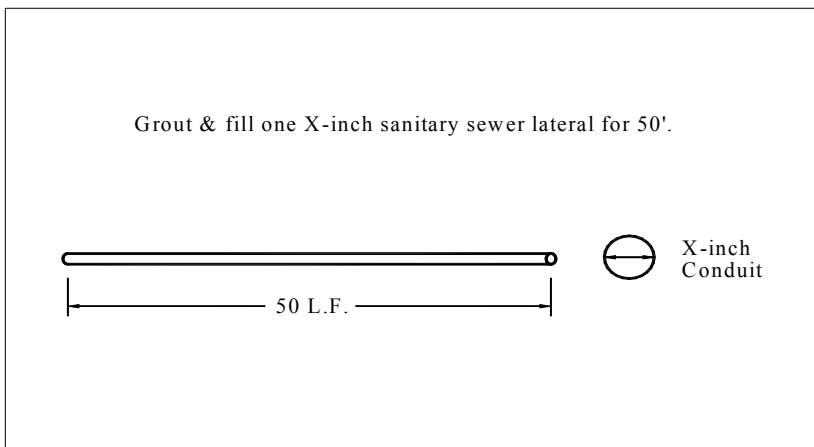

Activity SA06 Grout fill one X-inch sanitary sewer lateral for fifty linear feet.

Lowest Duration: 3 days
Average Duration: 4 days
Highest Duration: 6 days

Influencing Factors:

- Depth of pipe
- Soil conditions
- Permitting
- Weather
- Availability of labor and equipment
- Contractor availability

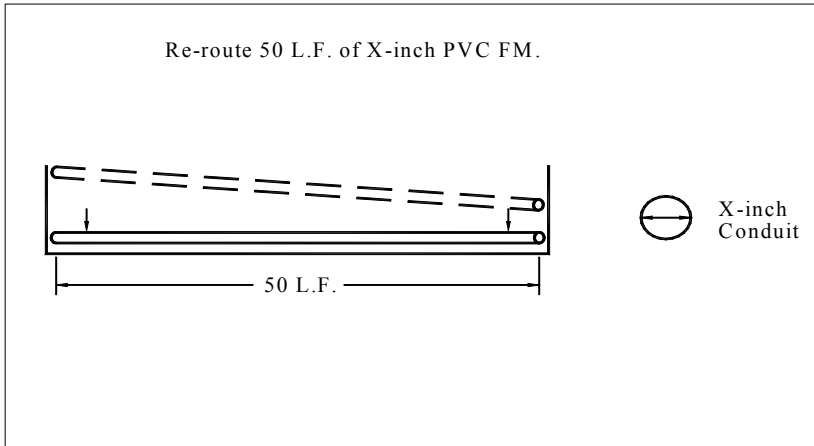

Activity SA07 Furnish and install one manhole.

Lowest Duration: 1 day
Average Duration: 4 days
Highest Duration: 8 days

Influencing Factors:

- Clearing and grubbing
- Ordering the material/Fabrication
- Availability of labor and equipment
- Soil conditions
- DOT permits
- Weather

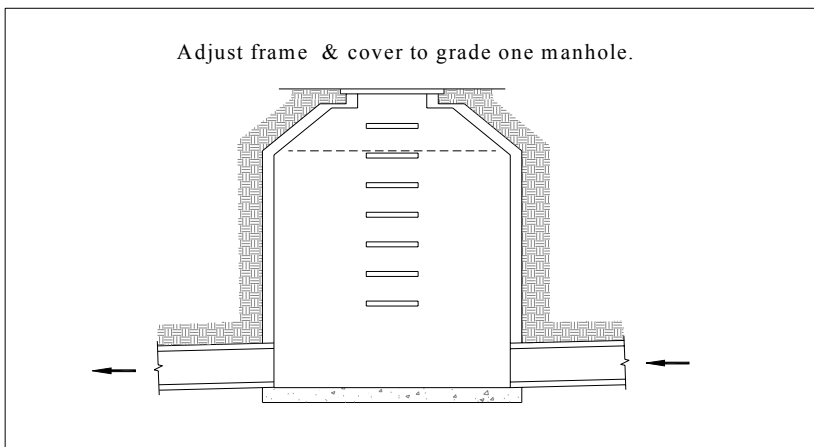

Activity SA08 Adjust ring and cover to grade for one manhole.

Lowest Duration: 0.5 days
Average Duration: 1 day
Highest Duration: 2 days

Influencing Factors:

- Soil conditions
- Permitting
- Weather
- Availability of labor and equipment

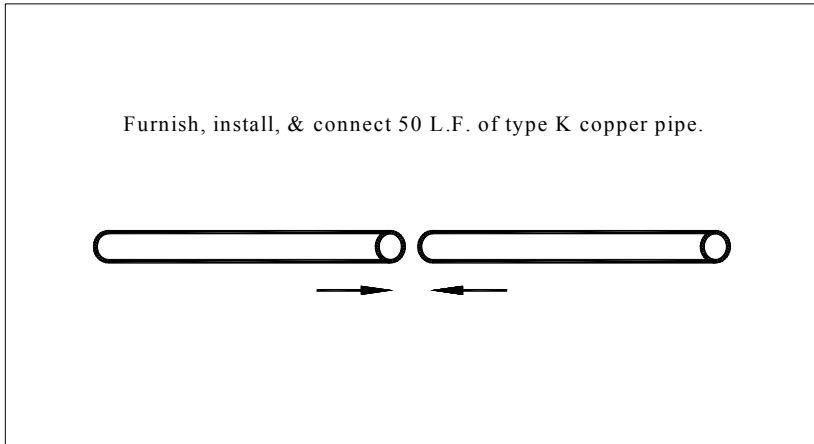

Activity WA01 Furnish, install, and connect fifty linear feet of Type K copper pipe.

Lowest Duration: 1 day
Average Duration: 5 days
Highest Duration: 20 days

Influencing Factors:

- Clearing and grubbing
- Ordering the material/Fabrication
- Availability of labor and equipment
- Soil conditions
- DOT permits
- Weather

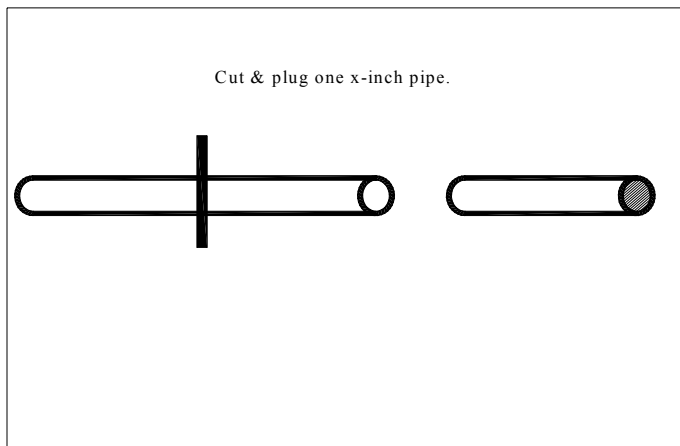

Activity WA02 Cut and plug one X-inch pipe.

Lowest Duration: 0.5 days
Average Duration: 2 days
Highest Duration: 8 days

Influencing Factors:

- Depth of pipe
- Soil conditions
- Permitting
- Weather
- Availability of labor and equipment

Adjust one water valve box to grade.

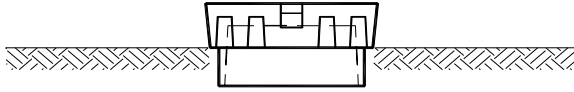

Activity WA03 Adjust one water valve box to grade.

Lowest Duration: 0.25 days
Average Duration: 0.5 days
Highest Duration: 2 days

Influencing Factors:

- Soil conditions
- Permitting
- Weather
- Availability of labor and equipment

Adjust one X-inch water main.

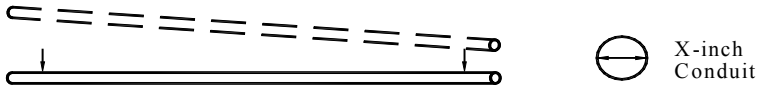

Activity WA04 Adjust one X-inch WM.

Lowest Duration: 0.25 days
Average Duration: 1 day
Highest Duration: 4 days

Influencing Factors:

- Clearing and grubbing
- Availability of labor and equipment
- Soil conditions
- DOT permits
- Weather
- Length of adjustment
- Vertical or horizontal adjustment



Activity WA05 Remove and replace fifty linear feet of X-inch WM.

Lowest Duration: 0.5 days
Average Duration: 1 day
Highest Duration: 5 days

Influencing Factors:

- Soil conditions
- Permitting
- Weather
- Availability of labor and equipment

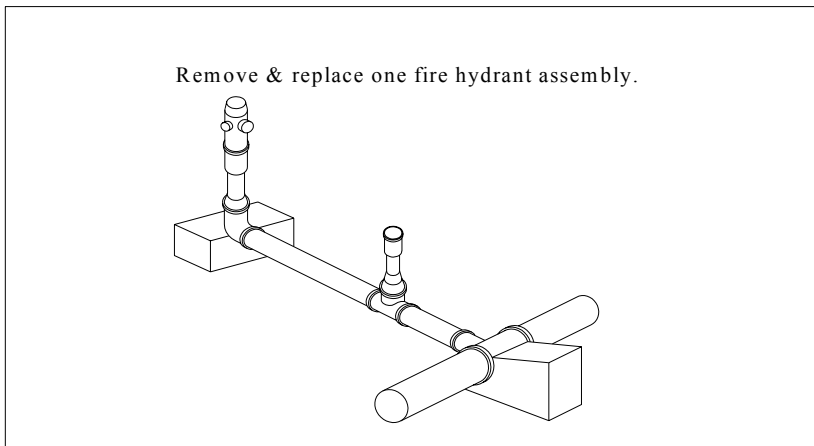

Activity WA06 Furnish and install one fire hydrant assembly.

Lowest Duration: 0.5 days
Average Duration: 3 days
Highest Duration: 10 days

Influencing Factors:

- Availability of assemblies
- Perpendicular or parallel to water main
- Permitting
- Weather

Availability of labor and equipment

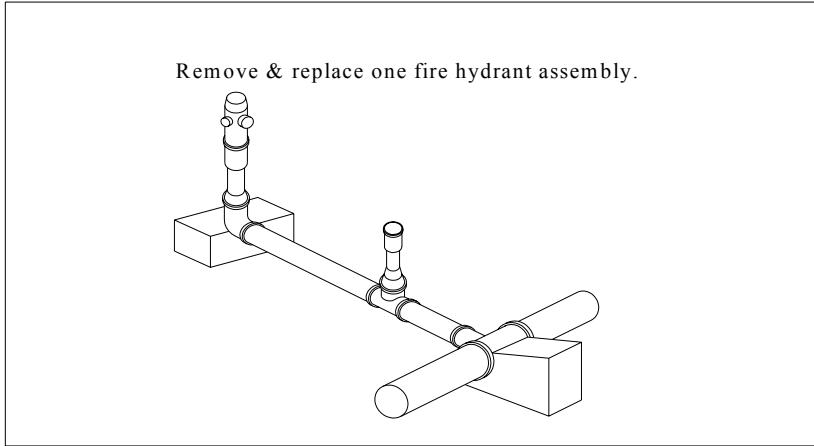

Activity WA07 Remove and replace one fire hydrant assembly.

Lowest Duration: 1 day
Average Duration: 6 days
Highest Duration: 16 days

Influencing Factors:

- Availability of assemblies
- Perpendicular or parallel to water main
- Permitting
- Weather
- Availability of labor and equipment
- Removal time
- Removal of concrete block at the elbow

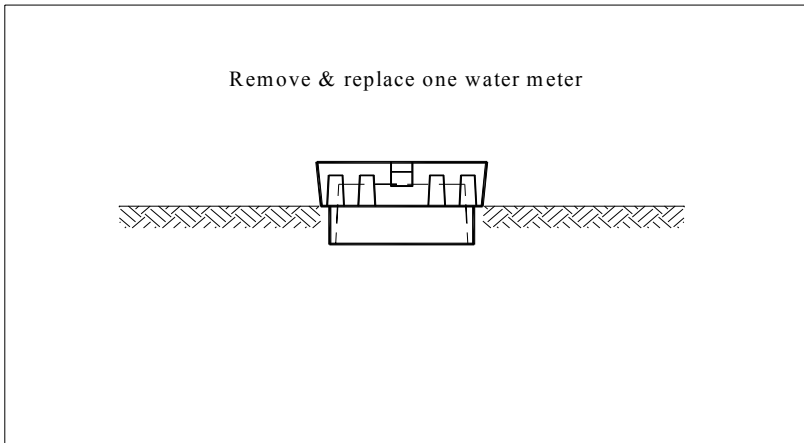

Activity WA08 Remove and replace one water meter.

Lowest Duration: 1 day
Average Duration: 3 days
Highest Duration: 4 days

Influencing Factors:

- Soil conditions
- Permitting
- Weather
- Availability of labor and equipment

Relocate one water meter

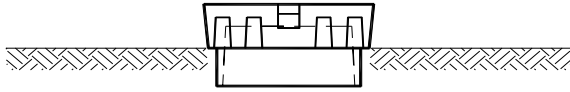

Activity WA09 Relocate one water meter.

Lowest Duration: 1 day
Average Duration: 3 days
Highest Duration: 4 days

Influencing Factors:

- Soil conditions
- Permitting
- Weather
- Availability of labor and equipment