



Florida Department of Transportation

RICK SCOTT
GOVERNOR

605 Suwannee Street
Tallahassee, FL 32399-0450

ERIK R. FENNIMAN
INTERIM SECRETARY

December 20, 2018

This Memo has expired

DCE MEMORANDUM NO. 24-18
(FHWA Approved: 12/19/2018)

TO: DISTRICT CONSTRUCTION ENGINEERS
FROM: David A. Sadler, P.E., Director, Office of Construction **David A Sadler**
COPIES: Bob Burleson, Ananth Prasad, Brian Blanchard, Courtney Drummond, Tim Lattner, Amy Tootle, Stefanie Maxwell, Chad Thompson, Nick Finch
SUBJECT: INDEX 102-655 TRAFFIC PACING

Digitally signed by
David A Sadler
Date: 2018.12.20
12:40:35 -05'00'

The Department has revised Standard Plans, **Index 102-655 Traffic Pacing** (see attached), which will be implemented for projects beginning with July 2019 lettings. The purpose of this change is to clarify that this Index may be used for operations other than just overhead work and removes the limitation to work only on limited access facilities. In addition, a note was added stating that a site-specific traffic control plan is not required for work durations of less than five minutes.

This memorandum serves as a blanket approval to process a \$0.00 contract change to incorporate the revised Index 102-655 for all active construction projects and all projects let prior to July 2019 lettings and should be attached to the Work Order or Supplemental Agreement.

Should you have any questions, please contact Daniel Strickland at 850-414-4352.

DAS/ds
Attachment

TRAFFIC PACING GUIDE

Traffic pacing is a traffic control technique to slow but not stop traffic to facilitate short duration work operations without an elaborate and difficult detour or diversion. Traffic Control Officers pace or slow the traffic to a speed that provides approximately 20-30 minutes to perform the work operation. The Department has frequently used this technique for setting bridge beams, overhead sign structures and replacing overhead sign panels.

CHANGEABLE MESSAGE SIGNS (Typical Placement and Messages)

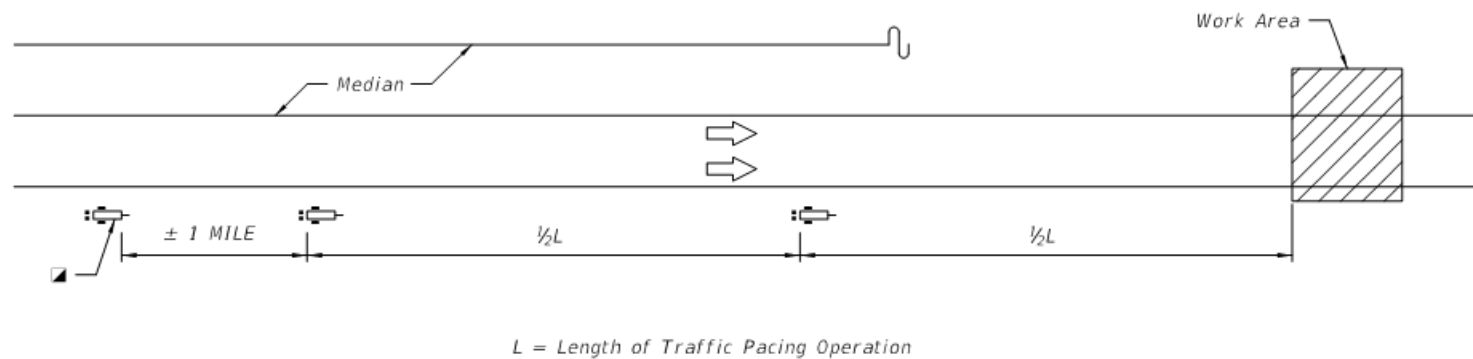

CHANGEABLE MESSAGE SIGN MESSAGE (MAINLINE AND RAMPS)

Symbols

- Channelizing Device (See Index 102-600)
- ☐☐ Marked Police Vehicle with Flashing Blue Lights
- ☐ PCMS, Portable Changeable Message Sign
- ▲ To be placed the day of pacing operation
- ➡ Lane Identification and Direction of Traffic

ONE WEEK PRIOR TO
PACING OPERATION

DURING DAY
OF PACING OPERATION

DURING PACING
OPERATION

EXPECT DELAYS ON	MMM DD-DD X AM - X AM
ROAD WORK TONIGHT	EXPECT PERIODIC DELAYS
SLOW TRAFFIC AHEAD	BE PREPARED TO STOP

NOTICE

This Index represents the minimum requirements for traffic pacing operations on the State Highway System.

Develop a site specific traffic control plan for each pacing operation location.

TRAFFIC PACING GENERAL NOTES

1. Install ROAD CLOSED (W20-3) signs approximately 1000' prior to the work area. These signs shall remain covered until the pacing operation begins and covered when the pacing operation has ended.
2. Prior to requesting that the traffic control officer supervisor initiate the pacing operation, the contractor shall ensure that the necessary equipment is properly positioned (off the roadway) for the construction activity requiring the traffic pacing operation.
3. Truck mounted attenuator(s) with changeable message sign(s) are required to protect workers and/or equipment positioned in a travel lane(s) at the work area during the pacing operation from an errant vehicle. If no workers and/or equipment are positioned in a travel lane(s) at the work area, truck mounted attenuator(s) are not required.
4. A traffic control officer supervisor shall be stationed at the work area continuously throughout the pacing operation to insure radio communications between the contractor and/or the project administrator, and all the police vehicles involved in the pacing operation.
5. When more than one pacing operation is required in one work period the contractor shall allow sufficient time between pacing operations to permit traffic to return to normal speeds and flow. Additional time may be required between pacing operations to allow traffic to resume normal speeds and flow upstream of the work area as determined by the project administrator or traffic control officer supervisor.
6. For work durations of less than five minutes, coordinate with traffic control officer to provide resources necessary for pacing traffic. Portable changeable message signs, truck-mounted attenuators, ROAD CLOSED signs, and site specific traffic control plans are not required for such operations. Use traffic pacing distance values from the five minute column of the table on Sheet 3.

TRAFFIC CONTROL PLANS OR TECHNICAL SPECIFICATION

1. The specific activities and locations, along with allowable times of day and days of the week, when pacing will be allowed should be clearly detailed in the traffic control plans or technical specification. If there are specific holiday or special event dates that, due to anticipated traffic congestion, pacing operations should not be allowed, these dates should also be spelled out in plans or specifications. When detailing the specific activities and locations of pacing activities, identify the minimum number of traffic control officers needed for each function and location of the pacing operation. If there are certain work activities that need to be completed prior to the contractor starting the work anticipated during the pacing operation, the activities should be clearly detailed in the plans or technical specification.
2. When developing a pacing plan, failsafe "stop points" should be identified for those work operations in which a construction problem could create a condition that could not be immediately cleared. A failsafe stop point is the last safe egress from the highway facility prior to traffic coming upon the work that is being completed during the operation. In the unlikely event that the work is not completed during the time estimated for the pacing, the plans or specification should direct the pacing to not proceed past the failsafe stop point until the highway is cleared. In the event of major construction problem that cannot be immediately cleared, traffic can then be diverted off the facility.
3. The traffic control plans or technical specification should require the contractor to submit a pacing plan in advance of the operation. The pacing plan should outline the contractors expected equipment and personnel, outline the operation, and include a contingency plan should any of the contractor's critical equipment break down. If the project includes a damage recovery clause, the traffic control plan or technical specification should be clear that the damage recovery applies to the pacing operation as well.
4. Changeable message signs shall be displayed one week prior to work using messages described in the traffic pacing plan. The number and location of changeable message signs shall be called out in the traffic control plans.

10/18/2018 3:45:08 PM

MAINLINE PACING DETAILS
(1 DIRECTION OF FOUR LANE ROADWAY EXAMPLE)

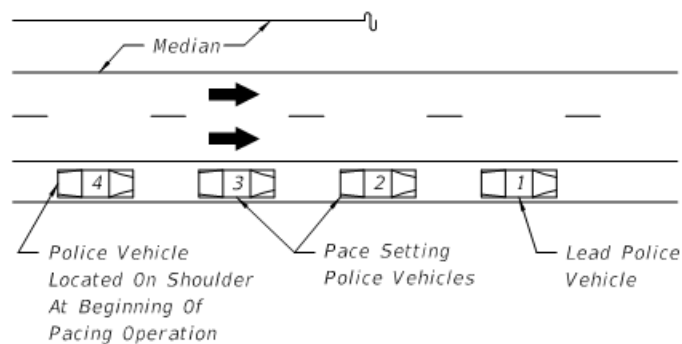

STAGE ONE

1. Four police vehicles located upstream of the work area at the beginning location of the traffic pacing operation with flashing blue lights off.

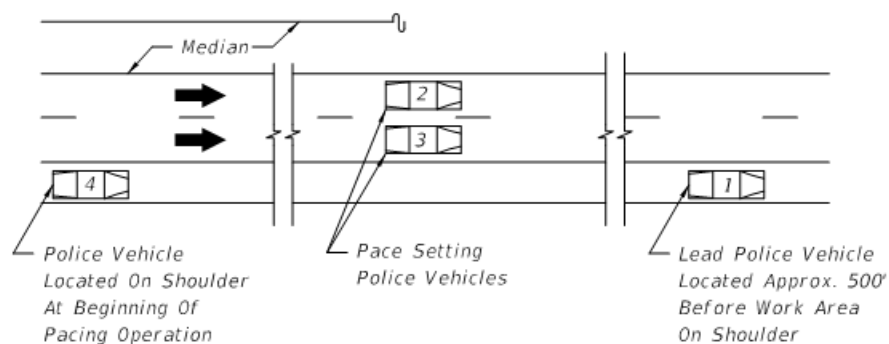

STAGE THREE

1. The two pace setting police vehicles shall begin to slow to the pacing speed (20 mph is preferred, 10 mph minimum), for the duration of the traffic pacing operation.
2. The lead police vehicle (flashing blue lights off) shall match the speed of the last vehicles ahead of the pacing vehicles and continue following traffic until a point approximately 500' in advance of the work area. The lead police vehicle shall then come to a complete stop on the right shoulder and turn on its flashing blue lights. If required, crash truck(s) with rear mounted impact attenuator(s) and changeable message sign(s) shall move into the travel lanes approximately 200 ft. upstream of the work area with the impact attenuators down and operating once traffic has cleared the work area.

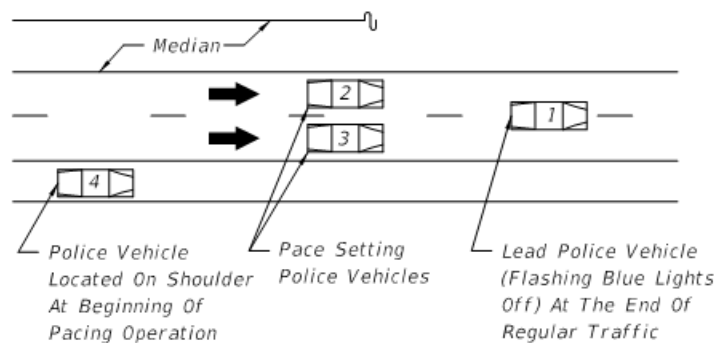

STAGE TWO

1. Once the police vehicles are in place and the traffic control officer supervisor at the work area notifies all officers to begin the traffic pacing operation, the last three police vehicles shall turn on their flashing blue lights. The first three police vehicles shall enter the travel lanes with the second and third police vehicles immediately forming a side by side "pacing operation" of all lanes behind the lead police vehicle (flashing blue lights off).

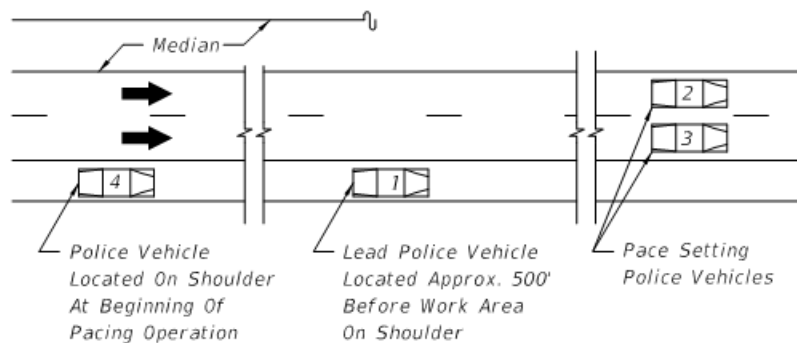

STAGE FOUR

1. When the pace setting police vehicles are within approximately two miles of the work area they shall notify the onsite traffic control officer supervisor who will immediately inform the contractors on site supervisor of their location. Once the contractors on site supervisor has been notified of the pacing vehicles location, the contractor shall begin to clear the travel lanes of all equipment and debris in order to reopen all travel lanes.
2. In case of emergency the pace setting police vehicles shall come to a complete stop once they reach the lead police vehicle. If no emergency is encountered, the crash truck(s) shall be moved from the travel lanes and the two pace setting police vehicles shall clear the work area and immediately move to the right shoulder or an area designated by the traffic control officer supervisor and turn off the flashing blue lights. Once the two pace setting police vehicles pass the work area, the traffic control officer supervisor shall instruct the lead and last police vehicles to turn off their flashing blue lights.

RAMP PACING DETAILS

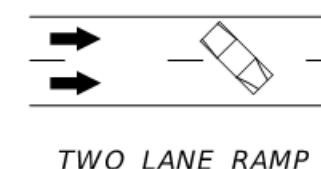
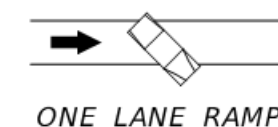

RAMP CLOSURE DETAIL

1. Once notified by the on site traffic control officer supervisor to begin the traffic pacing operation each police vehicle at the indicated ramp shall turn their flashing blue lights on and position the vehicle across the ramp lane(s) to close ramp access.
2. Once the pacing operation passes the closed on ramp the police vehicle on the ramp shall turn off the flashing blue lights and move from the ramp lane(s) to allow traffic to enter the mainline pacing operation.

GENERAL NOTES

1. Each Traffic Control Officer shall have a marked vehicle with flashing blue lights, for the pacing operation. The location and number of officers at each location will be as follows:

No. Of Traffic Control Officers With Vehicles	Function	Location
1 min.	Supervisor	Work Area
1 Lead Vehicle	Varies	Mobile operation
1 for each travel lane	Pacing Operation	Mobile operation beginning x miles upstream and terminating at the work area
1 Stationed at the Beginning of Pacing Operation	Advanced Warning to Motorist	Stationed at the Beginning of Pacing Operation
1 for each entrance ramp	Entrance Ramp Roadblocks	One at each of the entrance ramps upstream of the work area

10/18/2018 1:58:53 PM

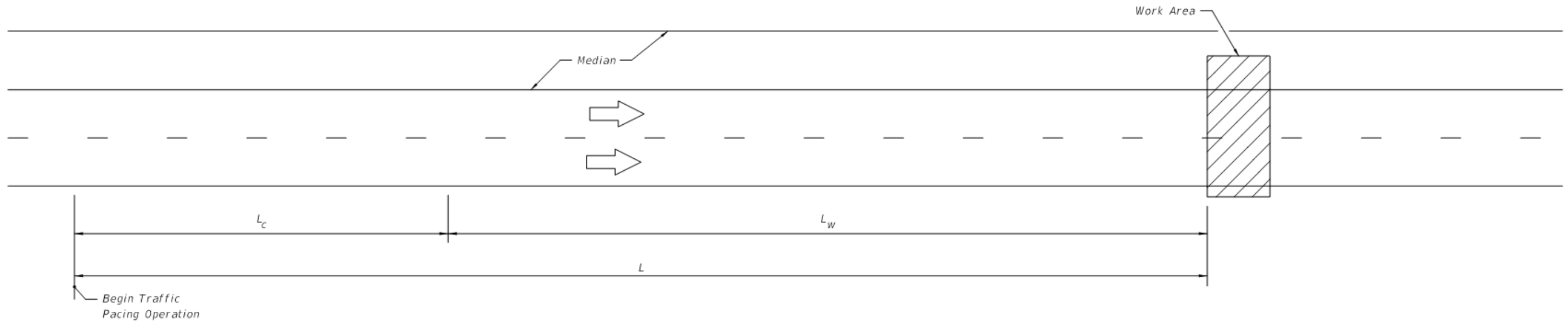

DESIGN CONSIDERATIONS:

The design shall evaluate the actual distance required for the pacing operation based on site specific features such as: roadway geometrics, pacing speeds, regulatory speeds, interchange spacing, work duration, availability of traffic control officers, traffic volumes and maximum queue length.

The starting point of a traffic pacing operation must consider the following factors: the speed of the pacing vehicles, the location of entrance ramps, horizontal and vertical alignment of the facility.

In some instances, it may be necessary to close a lane at the work site to position a crane(s) and the materials to be lifted.

All material to be installed shall be on-site before the traffic pacing operation begins.

It may be necessary to install temporary barrier walls to protect pre-positioned and assembled materials in the right of way.

The minimum speed allowed for a pacing operation is 10 mph with 20 mph the preferred speed.

The maximum allowed work duration is 1/2 hour (30 min).

The maximum practical pacing operation length is 10 miles.

S_r = Regulatory speed (mph)

S_p = Pacing speed (mph)

t_w = Work duration (min)

L = Total pacing distance in miles

$$L = \frac{t_w}{60} S_p \left(\frac{S_p}{S_r - S_p} + 1 \right)$$

$$L = L_c + L_w$$

L_c = distance paced vehicles must travel before the vehicles at regulatory speed have cleared the work zone

$$L_c = \left(\frac{t_w}{60} \times S_p^2 \right) \frac{1}{S_r - S_p}$$

L_w = distance paced vehicles travel while work is performed

$$L_w = \left(\frac{t_w}{60} \times S_p \right)$$

F_{HV} = Heavy Vehicle Factor

$$F_{HV} = 1 + \left(\frac{P_t}{100} \times 0.5 \right)$$

P_t = % Trucks

TRAFFIC PACING DISTANCES (L) miles						
$S_p=20; pcphpl \leq 1,750$						
S_r	t_w (min)					
	5	10	15	20	25	30
70	2.3	4.7	7.0	9.3	*	*
65	2.4	4.8	7.2	9.6	*	*
60	2.5	5.0	7.5	10.0	*	*
55	2.6	5.2	7.9	*	*	*
50	2.8	5.6	8.3	*	*	*

* Calculation required, for additional guidance see FDOT Design Manual 242.

NOTES FOR TABLE:

t_w is the total time allowed for work activity in minutes. This time starts just after the last vehicle traveling at the pre-pacing regulatory speed clears the work area and ends just as the pacing operation reaches the work area. t_w must include the time required to clear the roadway of equipment, materials, and personnel.

Demand volume may not exceed 1,750 pcphpl (passenger cars per hour per lane) without a site specific design. Traffic counts can be obtained from the Office of Planning, or you may need to collect traffic counts. Hourly directional traffic volumes must be converted to pcphpl using the following:

$$pcphpl = \left(\frac{\text{Hourly Directional Volume}}{\# \text{ Lanes (each direction)}} \right) \times \text{Heavy Vehicle Factor}$$

10/18/2018 1:58:54 PM