

Section 5.14

FIELD RECORDS AND CONTRACTOR'S CERTIFICATIONS

5.14.1 Purpose

This procedure describes the methods of maintaining the various field records required by the Department to substantiate final estimates quantities. The methods outlined are generally applicable to any field notes, but they are particularly pertinent to those used in the calculation or verification of final pay quantities.

The Contractor's Certification of Quantities forms are also described herein. These Certification forms are required by the Department for the Contractor to document and certify the quantities of specific installed items for which payment is included in a monthly estimate.

5.14.2 Authority

Sections [20.23\(3\)\(a\)](#) and [334.048\(3\)](#), Florida Statutes (F.S.)

5.14.3 References

[Standard Plans](#)

[Construction Automated Reporting System \(CARS\) Menu](#) — Internal Link

[National Institute of Standards and Technology \(NIST\) Handbook-44](#)[National Institute of Standards and Technology \(NIST\) Handbook-44](#)

5.14.4 Field Records

Field Records should be prepared assuming that the user has no familiarity with the work being recorded. The **Field Records** are important site source records for establishing pay quantities. They may be required as evidence in any arbitration or lawsuit. All **Field Records** shall be submitted as part of the **Final Estimates Documentation**. Below is the allowed type of **Field Records**:

(A) Standard Bound Field Book

A Surveying/Engineering field book that is typically hard covered. Most have gridlines, table, or graph paper. Its pages are typically waxed or specially coated to withstand moisture from ruining its contents. These book covers are typically bright orange or yellow in color.

(B) Site Source Records/Forms

Any supporting documentation (spreadsheet, electronic tabulation, etc.) or Department form use to substantiate final quantities.

(C) Form 700-050-61, Final Measurement Miscellaneous

This form simulates a **Field Book** page and is preferred over standard bound field books, since it results in savings to the Department and it can be maintained electronically.

5.14.5 General Instructions

- (A) Identify the front cover of each **Standard Field Book** used by including the Federal Aid Project Number, Financial Project Identification Number, Contract Number, Field Book Number, State Road Number, and the general contents of that book in bold letters. On the back binding (spine) of each **Field Book**, show the Field Book Number and the Financial Project Identification Number. (See [Attachment 5.14-1](#) for Sample Field Book Identification.)
- (B) When the **Final Measurement Miscellaneous Form** is utilized, include the same project information listed in (A) above at the top of each form used. It is recommended to maintain these forms electronically; therefore, it is unnecessary to bind these forms together and provide Field Book Numbers.
- (C) Each **Field Book** shall be clearly indexed with a complete list of the contents beginning on the first lined page, which is to be numbered page one. All following pages that are used to record notes shall be numbered sequentially in the upper right corner of each page.
- (D) The date, weather conditions, and the name(s) of the field party shall be shown on the **Field Records** and at the beginning of each day's notes. Well documented **Field Records** are indispensable in the event of litigation.

- (E) Corrections shall be made by striking through the incorrect data and inserting the correct data. All corrections shall be initialed and dated by the person making the correction.
- (F) Do not cut or otherwise remove pages from any **Field Book**. If an entire page is found in error, mark the original page as **VOID**, initial, date, and make a note referring to the page where that item of work was corrected.
- (G) Keeping notes on loose-leaf or scratch pads and transferring them to the **Field Books** or **Final Measurement Miscellaneous Form** is prohibited. Field notes shall be entered directly into the field book or the Department's form as the site source document.
- (H) **Field Records** shall always be legible [especially when inputted into the Electronic Document Management System (EDMS)], and include sufficient sketches and explanatory notes to convey the intent to a person who is not familiar with the job. Pay item numbers, original/final x-sections, and other relevant information shall be included. Good sketches are most important when recording final measurements. The details of the sketches shall be sufficient to clearly show the extent of the work as well as any exceptions.
- (I) Use standard symbols and abbreviations. Keep the notes simple and avoid making ambiguous statements.
- (J) Show all pertinent measurements and observations. Use a degree of accuracy that is consistent with operations. If there is any doubt about the need for data, record it. Review the data for accuracy and completeness before leaving the field.

NOTE: Ensure that Plan Quantity Pay Items are not field measured. Only measure field changes or plan errors for Plan Quantity Pay Items.

- (K) A complete summary shall be made for each item at the end of its field notes. The summary total for each item will then be checked by the personnel doing the final estimate and entered on the Summary of Quantity Sheet(s). The summary, and the **Field Record** shall be properly cross-referenced.
- (L) Keep the calculations and measurements for Federal Aid participating and non-participating items separated. This also applies to **Utility Work by Highway**

Contractor Agreements (UWHCA) and Locally Funded Agreements (LFAs).

- (M) When more than one project (state or federal) is constructed under the same Contract, separate ***Field Records*** shall be kept for each project, keeping measurements and other data separate for each project.
- (N) ***Field Records*** for projects let under separate contracts shall never be recorded in the same ***Final Measurement Miscellaneous Form*** or ***Field Book***.
- (O) All ***Field Books*** shall be scanned into EDMS for submittal with the ***Final Estimates Documentation***. The original ***Field Book*** may be destroyed.
- (P) When documenting any data on the grid sheets, neatness, and legibility give credence to the accuracy of field notes and the calculations which they support.
- (Q) ***Field Records*** containing alignment data shall contain all the necessary information for horizontal control for new construction projects and major widening projects.
- (R) ***Form 700-010-60, Pile Driving Record:***
 - (1) Individual pile record data is entered on the ***Pile Driving Record*** forms by bent or pier numbers.
 - (2) Data for alignment and pile driving shall be entered on the ***Pile Driving Record*** forms. These are permanent records and will be retained until the structure is removed.
- (S) ***Form 700-050-53, Final Measurements Site Source Record:*** This form is used to document quantities using the Latitude and Departure method. A Technician may use as many pages as needed for individual pay items.

5.14.6 Tabulation Forms

Tabulation Forms are site source records for establishing pay quantities.

(A) Form 700-050-54, Daily Report of Truck-Measured Material Site Source Record

This form is used to record truck quantities. When the final quantities are determined by certification/measurements of loose volume in truck bodies, the following procedures will satisfy the requirements for final pay records:

- (1) All trucks shall have an assigned unique number, along with the manufacturer's certification, or permanent decal, showing the truck capacity rounded to the nearest tenth of a cubic yard and placed on both sides of the truck. This includes the truck body capacity only, and any sideboards added will not be included in the certified truck body capacity provided by the contractor. The Project Administrator (PA) will randomly check the certified capacity on a selective number of trucks for accuracy by **using Form 700-050-54A, Truck Measured Sketch (Regular Bed)** and/or **Form 700-050-54B, Truck Measured Sketch (Irregular Shape Bed)**. This will not require the field personnel to climb into the body of the truck. When applicable, sideboard measurements will be transposed on these sheets and added to the certified capacity.
- (2) Using the trucks unique identification number and capacity, this form is used to record the quantity for each truck as it delivers a load of the material to the project.
- (3) The volume entered on this form for borrow material shall reflect the struck-measured volume (the dry measure having the contents leveled off and not heaped). The use of the struck-measured capacity shall apply to trucks, pans, or any other means of transport used. Documentation on loose volume bases, as measured in other hauling equipment, shall be made at the point of dumping on the construction site.
- (4) The PA shall request, at the **Preconstruction Conference**, that the Contractor provide a list of trucks to be used on Department's projects, along with their assigned numbers and their certified capacities. This list shall be submitted with the **Final Estimates Documentation**.
- (5) A separate line on the form will be used for each truck showing:
 - (a) Hauling company

- (b) Truck number
 - (c) Capacity certified
 - (d) Load count & time recorded
 - (e) Total volume for that truck that day
 - (f) Inspector's signature and title at the bottom of the page
- (6) Typical materials paid for by volume and recorded on the form include:
- (a) Borrow material
 - (b) Stabilizing material
 - (c) Cover material for prime coat, asphalt membrane interlayer or spread footings

(B) Form 700-050-56, Daily Log Sheet Miscellaneous Tabulation Form Site Source Record

This form is used when material is paid by weight. The **Field Records** are also kept for each truck load of material hauled each day and signed by the Inspector. This form is only used for Riprap and Sand-Cement Riprap. The Department's Engineering Quantities Program is available to verify quantities for payment and Plan Summary Boxes.

- (1) **Riprap:** quantities used and approved in each day's operation shall be recorded in this form. In the Remarks column, include the station, offset, and structure number of the placement location.
- (a) Measure in tons, in surface dry natural state, by railroad scales, truck scales, or barge displacement. See [Attachment 5.14-2](#) for Barge Displacement Calculation example.
 - (b) Ensure concrete removed from an existing structure (per plans) and paid for as Removal of Existing Structures is not paid for again as Riprap.
 - (c) For a toe wall, only the volume of sand-cement riprap, concrete blocks, or poured-in-place concrete placed within the neat lines

shown in the plans shall be included in the volume calculation of the final toe-wall quantities. See [Attachment 5.14-3](#) for Toe Wall Calculations example.

- (2) **Sand-Cement Riprap:** Document the volume (in cubic yards) of sand used in the sand-cement mixture per day or for each location. If the sand cement is proportioned by weight, use the conversion factor for sand of 85 lbs/ft³, per **Specifications Section 530-4.1**. Delivery tickets showing the batch weights of sand and cement used shall be submitted. (See [Attachment 5.14-4](#) for a Delivery Ticket sample.)
 - (a) When the pay quantity for sand cement is determined by the volume of sand, calculations from sketches and dimensions of the batch box capacity (or other approved measure) should be verified.

Payment for riprap shall not be made solely on the quantity delivered by truck and placed by the Contractor. For example, the quantity of riprap for a triple concrete pipe 84" in diameter is 31.1 CY and this quantity shall be adhered to as maximum payment. No compensation will be made for material placed that is beyond the neat lines shown in the plans. A sketch of the riprap structure must be submitted with authorized dimensions and volume calculations if not constructed according to Plans. This sketch must be included in the **Field Records**. (See [Attachments 5.14-5](#) and [5.14-6](#) for an example of a Riprap Sketch and Sand Cement Riprap Pay Analysis.)

To achieve this objective, the PA must maintain and exercise control of the riprap placement operation as follows:

If during the course of riprap placement, the PA determines that the Contractor is placing the material too thick or beyond required limits, the PA must submit written notification to the Contractor. In addition, the Inspector shall include the station, offset structure, and the words "**Partial Pay**" or "**No Pay**" on the form collected for materials which are either partially or completely placed outside the limits authorized by the PA.

NOTE: When box beam scales are used and the net weight is given automatically, only the net weight is required to be recorded.

(1) Resident Office Responsibility

The material quantities represented in the forms shall be reconciled. Multiple trucks may be recorded on one form as long as each individual truck is identified by number and company name.

Department forms shall be cross-checked with the Contractor or subcontractor's records on a regular basis (daily or weekly). Any differences that may exist in pay quantities will be reconciled immediately. This systematic comparison of source records will avoid misinterpretations concerning final pay quantities.

A summary shall be made from the form totals in the **Plan Summary Boxes**. Additional summary boxes can be created from the Excel spreadsheets included in the **CADD_[FPID].zip file**, in the **Calculations** directory. (See figure.)

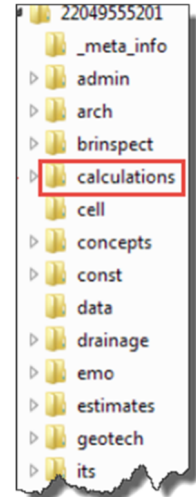

The output shall be submitted with the final estimate and shall be cross-referenced in the Plan Summary Boxes.

5.14.7 Contractor's Certification of Quantities

(A) Form 700-050-62, Contractor's Certification of Quantities (MOT, Signs, etc.)

This form is ~~currently~~ provided in the [FDOT Excel Construction Forms Excel Forms Manager plugin](#) which can be ~~download~~ installed from the Department's [Construction Downloads webpage](#) application located on the CARS Menu. The Contractor will document and certify all 102 pay items. ~~This form will be sent to the Department's collaboration site by the PA, once the project is awarded and before Contractor begins work, for the Contractor's use.~~ All MOT pay items within a Contract will be listed on the form once generated.

The form shall be signed by both the Contractor's Authorized Agent and the Worksite Traffic Supervisor, then submitted monthly to the PA for payment. The PA will submit these certifications with the **Final Estimates Documentation**. The Contractor's Authorized Agent must be an employee of the Prime.

This form is not required on Lump Sum and Design Build contracts.

NOTE 1: Cones are paid for under the MOT LS pay item.

NOTE 2: MOT LS pay item 102-1 is NOT adjusted by construction for overruns/underruns using the secondary units of days, see Item 102-1 of the [Basis of Estimates Manual Pay Item Database](#).

NOTE 3: [MOT Certifications that have been approved and paid on a previous progress estimate should not be retracted and revised if errors are discovered. Corrections are allowed, but should be done on the current/next progress estimate and make a note \(if possible\) of the correction on the current/next certification.](#)

(B) Form 700-050-67, MOT Painted Pavement Markings, Daily Worksheet and Form 700-050-68, Contractor's Monthly Certifications of Quantities

These forms are to be used by the Contractor for all the Traffic Striping and Marking pay items. These forms include the following pay items: 701, 702, 705, 706, 709, 710, 711, 713, and 102 striping items. The 102 striping pay items are also listed in this worksheet to eliminate the need for filling out two different forms. [For projects let July 2021 and forward, pay items 701, ~~706~~, 709, 711, and 713 will be paid as plan quantity, regardless of their inclusion on the Contractor's Certification. Raised Pavement Markers \(RPMs\) \(706-1 pay item\) are now final measure. Ensure the contractor is aware of the appropriate basis of payment for striping items.](#)

The Contractor is responsible for the measurements/counts for these items and payment for the certified quantities shall be approved by the Engineer. If the Engineer disputes a quantity certified by the Contractor, the Engineer must request justification for the disputed quantity from the Contractor. The Engineer must document in great detail if the quantity certified is not approved.

The form shall be signed by both the Contractor's Authorized Agent and the Worksite Traffic Supervisor, then submitted monthly to the PA for payment. The PA will submit these certifications with the **Final Estimates Documentation**. The Contractor's Authorized Agent must be an employee of the Prime.

This form is not used on Lump Sum and Design-Build contracts. See **CPAM Section 6.2** for more information.

NOTE 1: For the Lump Sum Pay Item 710-90, the Contractor should document the quantity as a percentage (in decimal form) on the daily worksheet, so when monthly certified sheet is tabulated the cumulative quantity is reported. The total quantity should be 1 Lump Sum (LS) once the Contractor completes this pay item.

NOTE 2: Payment under the Lump Sum Pay Item 710-90 shall only be made when the final lift of asphalt placement is complete. All intermediate stages of asphalt placement requiring striping are paid under the appropriate pay items.

NOTE 3: The Department's representative is not required to check or record MOT Signs and Striping quantities on a daily basis. During the estimate period, random spot checks shall be made and documented. These checks can be achieved in a combined effort with the Contractor. This approach should minimize disputed quantities. The Contractor is responsible for supplying the Department with accurate documentation of quantities.

NOTE 4: For RPM's (706-1 pay item), it is not intended for the Resident Offices to count individual RPM's. Using the Station to Station length divided by the ROM spacing will suffice.

(C) Form 700-050-70, Traffic Marking Certification (Worksheet)

This form is used for recording Initial Retroreflectivity Reading of White/Yellow Pavement Markings, Thickness, and Wet Weather in accordance with **Florida Method FM 5-541**, per **Specifications Section 710**.

The Contractor has the responsibility of measuring, recording, and certifying the Retroreflectivity on the Department's approved form and submitting to the PA. This form is signed by the Contractor or his representative and the Worksite Supervisor. The Department reserves the right to test the markings after three (3) days of receipt of the **Contractor's Certification**. Failure to allow the Department to complete this task will result in non-payment to the Contractor.

This form shall also be utilized on Lump Sum and Design-Build Projects. See **CPAM Section 6.2** for more information.

5.14.8 Approved Products List (APL) Item Records

(A) Contractor Responsibilities

The Contractor should provide APL numbers corresponding to pay items intended for use on the project to the PA (or designee) for record and verification. This includes items incorporated in the project on a permanent basis and all MOT items.

On projects with a Non-Standard Job Guide Schedule (JGS), the Contractor shall include all APL Spec Categories used on the project under the APL tab in the Materials Acceptance and Certification program (MAC).

(B) Resident Office Responsibilities

The PA (or designee) shall verify the APL information for specification conformance before the item is placed on the project and entered into the Pay Item Tracking System (PTS) application by the PA (or designee) prior to payment on the monthly estimate. For instructions, see the [PTS Handbook](#).

PAs shall confirm that all APL method of acceptance requirements are listed on the JGS on projects with a Standard JGS in the MAC System. On projects with a Non-Standard JGS, the PA shall ensure the Contractor has included all APL Spec Categories used on the project under the APL tab. Material Certification (MC) Reviewers will review the JGS and confirm that product(s) are included in PTS for each Spec Category as part of the MC Review in MAC and coordinate with the PA if there are any questions about the use of APL products.

5.14.9 Notifying the District Materials Office of Rock Base Measurements

(A) Resident Office Responsibilities

The PA shall notify the District Earthwork Coordinator or designee of the anticipated date and time of base measurements, whenever there is a measurement that requires Construction Training and Qualification Program (CTQP) qualified Earthwork Technicians to perform field measurements of base thickness. This notification process is the only efficient way the District Materials Office Staff can learn of upcoming base depth measurements.

5.14.10 Bulk-Weight Final Pay Records

Certified weight tickets for certain bulk weight shipments are acceptable as final payment records under the following conditions:

- (A) All weighing is done on state certified scales. The ticket must indicate gross, tare, and net weight.
- (B) The State of Florida will recognize any scale that has been certified by a state agency outside Florida using traceable standards. All 50 states have adopted and use the same laws as [Florida NIST Handbook-44](#).

- (C) Project personnel will record each truck number and time of loading, on **Form 700-050-56, Daily Log Sheet Miscellaneous Tabulation Form Site Source Record** at the rail head site.
- (D) All rail cars are visually inspected to ensure all material has been unloaded.
- (E) Material remaining in cars after job completion is to be hauled by truck to state certified scales and determine gross, tare, and net weights to make appropriate deductions from the car weights.
- (F) Hauling will be done in covered trucks to minimize loss of material. The single car weight is more accurate than weighing numerous trucks and with the **Form 700-050-56, Miscellaneous Tabulation** system as outlined above.

5.14.11 Fuel and Bituminous Adjustments

(A) Fuel Adjustments

On Contracts with an original Contract Time in excess of 120 calendar days, the Department will make price adjustments on each applicable progress estimate to reflect increases or decreases in the price of ~~gasoline or diesel fuel~~ from those in effect for the month in which bids were received. (See **Specifications Section 9-2.1.1.**) When an estimate is generated, ~~f~~Fuel ~~a~~Adjustments will be automatically calculated per the **Specifications** using pre-determined fuel factors for applicable pay items and the Price Index Tables. A complete list of Items that require fuel adjustments, ~~based off~~ [according to contract letting date](#), can be found on the Department's Construction Web site at:

<http://www.fdot.gov/construction/fuel&bit/Fuel&Bit.shtm>

NOTE 1: Fuel adjustments for this list of pay items will be generated automatically in SiteManager for conventional Contracts.

NOTE 2: Effective for contracts let January 2022 and forward, fuel adjustments will only be made on diesel fuel.

NOTE 3: Manual fuel adjustments shall be made in SiteManager for Contracts that call for Black Base Option only using the **Fuel Adjustment Report** below.

NOTE 4: To calculate manual fuel adjustments corresponding to thickness/105%/spread rate adjustments (see CPAM 11.4, Attachment A, Example 1 and 2), utilize the

Contractor's Lump Sum & Design Build Fuel Adjustment Certification
Fuel Adjustment (DB/LS) worksheet.

Fuel adjustments for the following pay items will be calculated in the **Fuel Adjustment Report**:

- Clearing and grubbing
- Structural Steel
- Black base option
- Composite base option

(1) **Fuel Adjustment Report**

To access the **Fuel Adjustment Report**, follow the steps below:

- Access the Construction Infonet – Internal Link State Construction Office application
- Login
- Select Ad-Hoc Reports System, then select Central Office (StateWide Reports) State Construction Dashboard
- Log in, Select Statewide Construction Dashboard Reports tab, and choose District
- Select the Estimates Estimate tab, then click Fuel Adjustment
- Select Fuel Adjustment Report – With NEW Base Options

The steps below explain how to create the **Fuel Adjustment Report**:

Enter the Contract ID and the estimate number the Adjustment Report is being created for. The estimate number is a four-digit field. Reports can only be created for one estimate at a time.

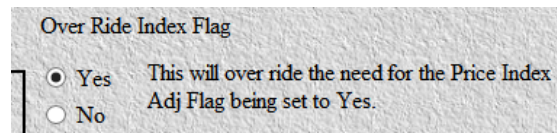
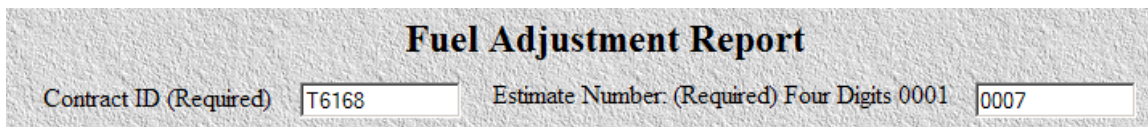
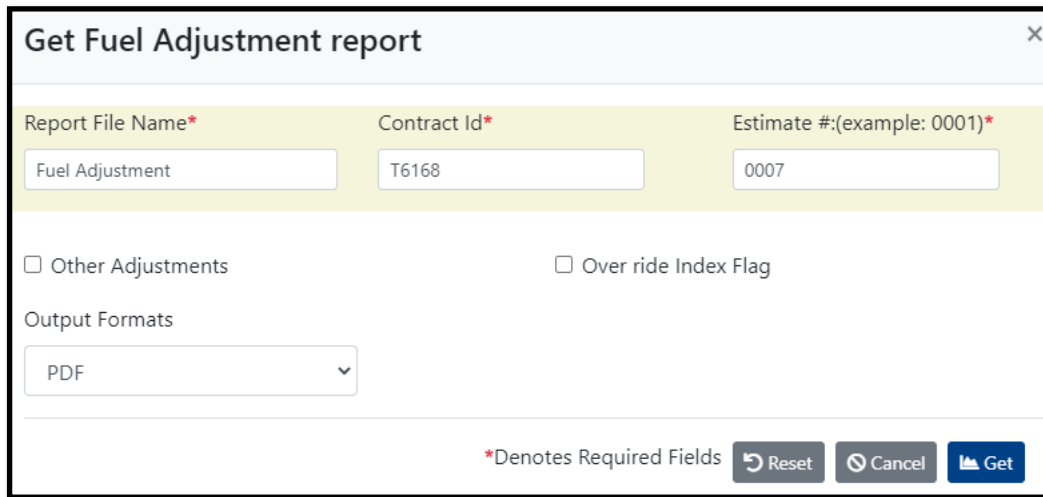

If the Fuel Adjustment "flag" was not set in SiteManager, select the "Over ~~r~~Ride Index Flag" option before and

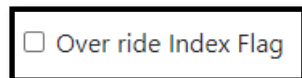

generating the report.

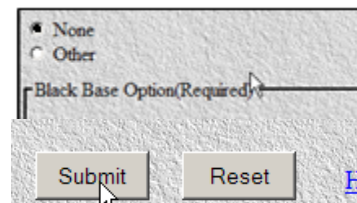

If there is not an All Black Base Option or Composite Base Option included in the Contract, select the "None" radio button on the main screen, then click "Submit-Get" to generate the report.

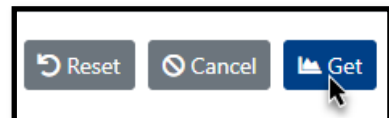

Enter the adjustments manually in SiteManager as a line item adjustment as required. The report cannot write the adjustments back to SiteManager.

(2) Using the Black Base or Composite Base Option

Black Base Option(Required)

None
 Other

Fin Project ID Base Items

If there is an All Black Base or Composite Base Option, select the "Other Adjustments" check

Other Adjustments

boxradio button. After selecting the "Other" radio button, the FIN Project ID and the Base Items fields will be populated with any associated pay items to the contract.

Black Base Option(Required)

Fin Project ID	Base Items	Qty
40557835201	0285709 -OPTIONAL BASE (BASE GROUP 09)	
40557835601	0285715 -OPTIONAL BASE (BASE GROUP 15)	
41462415201		
41462415601		

Select the FIN Project ID and Optional Base Item to calculate the fuel adjustment for the Black Asphalt quantity. If paying for a mixture of optional bases on this estimate, the Daily Work Report (DWR) quantity will be the total of

Asphalt and Limerock pay areas. Only enter the quantity of Black Base (or Composite Base) and select "Add Selected". Repeat as needed, then select "Get" to generate the report Submit.

Sample Fuel Adjustment Report

(3)

In this example

The screenshot shows a software interface with the following elements:

- Checkboxes: Other Adjustments, Over ride Index Flag
- Fields: Types* (dropdown with 'Black Base' selected), Projects* (dropdown with '40828665201' selected), BlackBase* (dropdown with '0450:0285701' selected), Qty* (input field with '50'), Items (input field with 'BLKBASE:40828665201;0450:0285701' selected).
- Buttons: 'Add Selected', 'Remove Selected', 'Reset', 'Cancel', and 'Get' (highlighted with a mouse cursor).

Two close-up screenshots of the software interface:

- The first shows a 'Qty' input field containing '50.00'.
- The second shows a 'New Quantities' input field containing '50.0000000;40557835201;0285715'.

For example, the DWR quantity is 192.24 SY, of which, only 50.0 SY is Asphalt Base.

~~(3)(1)~~ After adding the report parameters (shown above) and generating the report **Sample Fuel Adjustment Report**

~~Below, is an example of the report showing~~ the adjustment amount for diesel for the Asphalt Base will be shown. The adjustment amount generated in this report (\$38.38) needs to be added to SiteManager as a manual line item adjustment.

adjustments		=====			
SM Total Diesel Adjustment Amount:	\$	165.30			
Manual Total Diesel Adjustment Amount:	\$.00			
Total Diesel Adjustment Amount:	\$	165.30			
<table border="1"> <tr> <td>** Adjusted Amount for Diesel :</td> <td>\$</td> <td>38.38</td> </tr> </table>			** Adjusted Amount for Diesel :	\$	38.38
** Adjusted Amount for Diesel :	\$	38.38			
Adjusted Total for Diesel :	\$	203.68			



However, if all the DWR quantity (192.24 SY) is Asphalt Base, enter this amount into the quantity field. This will make the adjustment on all of the DWR quantity.

Diesel Adjustment					
0105	0160	4	25.300	SY	.1196 .659
0110	0285715		192.240	SY	.4359 .659
Asphalt Base option for quantity			192.24 fuel adjustment of \$	147.56 **	
0120	0334	1.12	22.430	TN	4.6220 .659

Site Manager Total:	\$165.30
Manual Total:	\$0.00
Total Amount:	\$165.30
** Adjusted Amount:	\$38.38
Adjusted Total:	\$203.68

Ln#	Item Code	Est Qty	Unit	Qty	Unit	Adjustm Factor	Index Differen!	Adjustmen Amount
Financial Project ID: 40557835201								
Diesel Adjustment								
0105	0160 4	25.300	SY			.1196	.6594	\$ 2.00
0110	0285715	192.240	SY			.4350	.6594	\$ 55.20
Asphalt Base option for Qty 192.24 Fuel adj of \$							147.56 **	
0120	0334 1 13	22.430	TN			4.6220	.6594	\$ 68.36

(4) Using the Clearing & Grubbing or Steel LS overrun

To use the Clearing and Grubbing Overrun part of the **Fuel Adjustment Report**, the Acres that this LS pay item is to be adjusted by must be known. The Steel overrun portion will work in a similar way.

~~**NOTE:** The report will allow overrun adjustments on estimates regardless of whether a payment on the Clearing and Grubbing pay item or the Steel Item was made. A \$0.00 Work Item on a DWR for Clearing and Grubbing or the Steel LS pay item will be required.~~
NOTE 1: Effective for contracts let April 2021 forward, clearing and grubbing will not be eligible to receive fuel adjustments.

The FIN Project ID list and pay item will automatically be populated after selecting the adjustment type when the "Over Runs" box is checked.

The screenshot shows a software window titled "Other Adjustments" with a checked checkbox. Below the title are four main sections: "Types*", "Projects*", "Clearing & Grubbing*", and "Qty*". The "Types*" dropdown menu is open, showing options: "Black Base", "Clearing & Grubbing" (highlighted), "Composite Base", and "Steel". The "Projects*" dropdown shows two project IDs: "42357215201" and "42357225201". The "Clearing & Grubbing*" dropdown shows "0075:0110 1". The "Qty*" field contains the value "0". There is also an unchecked "Over rid" checkbox in the top right corner.

The screenshot shows a software window with a checked "Over Runs" checkbox. Below it is a section titled "Clearing & Grubbing". This section contains a "Fin Project ID" field with two entries: "42357215201" and "42357225201". To the right of this field is a "Qty" input field. Further right are two buttons: "Add Selected >>" and "Remove Selected". To the right of these buttons is a "New Quantities" field.

After selecting the project and pay item to which the adjustment will be made, enter the quantity (in Acres) of the overrun adjustment. Then select the "Add Selected" button to add the quantity to the "ItemsNew-Quantities" box. (See below.)

Other Adjustments Over ride Index Flag

Types*	Projects*	Clearing & Grubbing*	Qty*	Items
Black Base Clearing & Grubbing Composite Base Steel	42357215201 42357225201	0075:0110:1	5	CLRGRB:42357215201:0075

Over Runs

Clearing & Grubbing

Fin Project ID

42357215201
42357225201

Qty: 5.0

New Quantities: 5.00000000:42357215201

Add Selected >> Remove Selected Get Submit

By selecting the "GetSubmit" button, the report will be generated. The overrun of Clearing and Grubbing can be found under the Diesel and Gasoline adjustment for this pay item. The project personnel will need to make individual line item adjustments for each dollar amount associated with Clearing and Grubbing in SiteManager.

Reset Cancel Get

Florida Department of Transportation Estimated Fuel Adjustment Report									
Vendor Id: F592871935		Vendor Name: ANDERSON COLUMBIA CO., INC.		For Est Nbr: 0002		Pay Period: 01/19/2009 to 02/15/2009			
Contract ID: T3276		Price Adjustment Flag: Y							
Sys Unit Code: E									
Financial Project ID: 42357215201									
Ln#	Item Code	Est Qty	Unit	Qty	Unit	Adjustment Factor	Index Difference	Adjustment Amount	
Diesel Adjustment									
0075	0110 1 1	.900	LS	2.900	AC	45.6400	-2.1755	\$	-259.15
						Item 0110 1 1 Over Run		5.000 AC adj of \$ -496.45 **	
0085	0120 1	3895.000	CV			.2015	-2.1755	\$	-1,707.57
0095	0285709	6181.000	SY			.4359	-2.1755	\$	-5,862.06
0100	0327 70 8	6307.000	SY			.0912	-2.1755	\$	-1,251.31
0105	0334 1 24	5222.980	TN			4.6220	-2.1755	\$	-52,522.81

The report will automatically add the total dollar amount for all Diesel adjustments.

		Unit	Adjustment Factor	Index Difference	Adjustment Amount
Total Diesel Adjustment Amount:					\$ -61,343.75
** Adjusted Amount for Diesel :					\$ -755.60
Adjusted Total for Diesel :					\$ -62,099.35
0075	0110 1 1	LS	45.6400	-2.1755	\$ -259.15 **
5.000 AC adj of \$ -496.45 **					
0085	0120 1	CV	.2015	-2.1755	\$ -1,707.57 *
0095	0285709	SY	.4359	-2.1755	\$ -5,862.06 *
0100	0327 70 8	SY	.0912	-2.1755	\$ -1,251.31 *
0105	0334 1 24	TN	4.6220	-2.1755	\$ -52,522.81 *

Site Manager Total:	-\$61,343.75
Manual Total:	-\$259.15
Total Amount:	-\$61,343.75
** Adjusted Amount:	-\$755.60
Adjusted Total:	-\$62,099.35

Example:
 -\$259.15
 + -\$496.45

 -755.60

(B) Bituminous Adjustment

Contracts will receive a bituminous adjustment if the Contract has an original contract time of more than 365 calendar days or more than 5,000 tons of asphalt concrete. The Department will adjust the price for bituminous material, excluding cutback and emulsified asphalt to reflect either increases or decreases in the **Asphalt Price Index (API)** of bituminous material from that in effect during the month in which bids were received. (See **Specifications Section 9-2.1.2.**) The Department will determine the API for each month and post it on the Construction website. When an estimate is generated, Bituminous Adjustments must be calculated per the **Specifications** using the **Asphalt Price Index** and the PA must add a manual line item adjustment to the estimate. **Asphalt Price Indexes** can be found on the Department's Construction website at:

<http://www.fdot.gov/construction/fuel&bit/Fuel&Bit.shtm>

For each monthly progress estimate, the Contractor will prepare, sign, and submit to the PA a **Contractor's Certification of Quantities** using the Department's current approved **Form 700-050-66**, which can be found at:

<http://www.fdot.gov/construction/fuel&bit/FuelForms.shtm>

This form will include the tonnage placed and accepted for the asphalt items that will receive a bituminous adjustment during the progress estimate. Adjustments will only be made on work accepted by the Department. If an adjustment is made and the work is later determined to be unacceptable, a deduction to the adjustment will be made on the next progress estimate. The asphalt items will be reported on the lead FIN Project ID in order to receive payment. (See [Attachment 5.14-7](#) for a sample Contractor's Certification of Quantities.)

NOTE: The Department will make a Bituminous Adjustment for Polymer PG76-22 Binder on all Contracts. The Criteria for Polymer PG76-22 will be as stated above. When a Composite Base item is specified in the Plans, a price adjustment for bituminous material will apply to that asphalt portion of the base only, according to **Specifications Section 9-2.1.2**.

(C) Resident Office Responsibility

The Resident Office (RO) personnel will verify monthly the fuel and bituminous material on projects that meet the criteria specified in **Specifications Section 9**. Fuel and bituminous adjustments will be based on the index of the estimate period the work was completed, not the estimate period of payment. This is especially important for adjustments made after final acceptance.

Example 1: After final acceptance, the project personnel found that fuel adjustments for black base were not applied during the contract. The project personnel would manually calculate the fuel adjustments based on the index for each estimate period the asphalt was completed, not the fuel index for the month of the final estimate. [The Lump Sum & Design Build Fuel Adjustment Certification can be used to generate the adjustment amount.](#)

Example 2: Asphalt was placed on the mainline for payment during the May estimate period, but 50 feet required removal and replacement due to a material failure. The contractor performed the removal and replacement during

the July estimate period. When the bituminous adjustment corrections are made, the removal correction will be made at the May index, and the placement will be at the July index. [The Lump Sum & Design Build Asphalt & Bituminous Adjustment Certification](#) can be used to generate the adjustment amount.

Example 3: Asphalt was incorrectly reported in the **QCRR** for an estimate period, and fuel & bituminous adjustments were paid on that amount. The following month if the QCRR is corrected, fuel and bit adjustments should be applied on the amounts corrected, as well as the asphalt placed in the new estimate period. These revised fuel and bit adjustments amounts can be calculated using the Lump Sum & Design Build Certifications LS/DB worksheets and the difference on what should be paid will be entered as a line item adjustment on the pay item.

The PA shall ensure the running total of each item's tonnage in the **QCRR** for the period represented and compare to the **Certification of Quantities** submitted. Any discrepancies shall be resolved with the Quality Control (QC) Manager before authorizing payment on the progress estimate. If a **Certification of Quantities** has been determined to show tonnage that wasn't accepted on the project, the QC Manager must be notified for justification and/or correction. The Certification of Quantities must be inputted into EDMS for reference as **Final Estimates Documentation** backup.

NOTE 1: Bituminous Certifications that have been approved and paid on a previous progress estimate should not be retracted and revised [if errors are discovered](#). Bituminous corrections are allowed, but should be done on the current/next progress estimate [and make a note of the correction on the current/next certification](#). For the removal and replacement asphalt adjustment process, see Example 2 above and **CPAM 11.4.4.3**.

NOTE 2: For Fuel and Bituminous Material Adjustments on Lump Sum, Design-Build, and other Alternative Contracts, refer to **CPAM Section 6.2**.

5.14.12 Cutoff Period

All **Certifications of Quantities** worksheets submitted by the Contractor need to represent the amount of material placed on the project and accepted by the Department for the estimate cutoff period. The estimates cutoff dates are provided on the State Construction Office website:

<http://www.fdot.gov/construction/CONSTADM/EstimatesCutOff.shtm>

The Contractor must request payment by submitting a **Certification of Quantities** no later than twelve o'clock noon Monday after the estimate cut-off or as directed by the PA. This is in accordance with **Specifications**. The Contractor's submitted quantities must be approved by the PA. Any disputed quantities need to be reconciled as soon as possible.

All digital signatures must be verified prior to acceptance by the Department. The RO must ensure each digital signature is from an approved digital signature authority and valid at the time the document was signed. The RO must also verify the document was not altered after the digital signature was applied.

5.14.13 Forms

The forms referenced in this manual can be found on the Department's website: <https://fms.fdot.gov/https://pdl.fdot.gov/>. Official forms provided by the Department shall be used without alteration or modification.

5.14.14 Attachments

Attachment 5.14-1	Field Book Identification
Attachment 5.14-2	Barge Displacement Calculation
Attachment 5.14-3	Toe Wall Calculation
Attachment 5.14-4	Delivery Ticket
Attachment 5.14-5	Sketch of Riprap Structure
Attachment 5.14-6	Sand Cement Riprap Pay Analysis
Attachment 5.14-7	Contractor's Certification of Quantities

Attachment 5.14-1 FIELD BOOK IDENTIFICATION

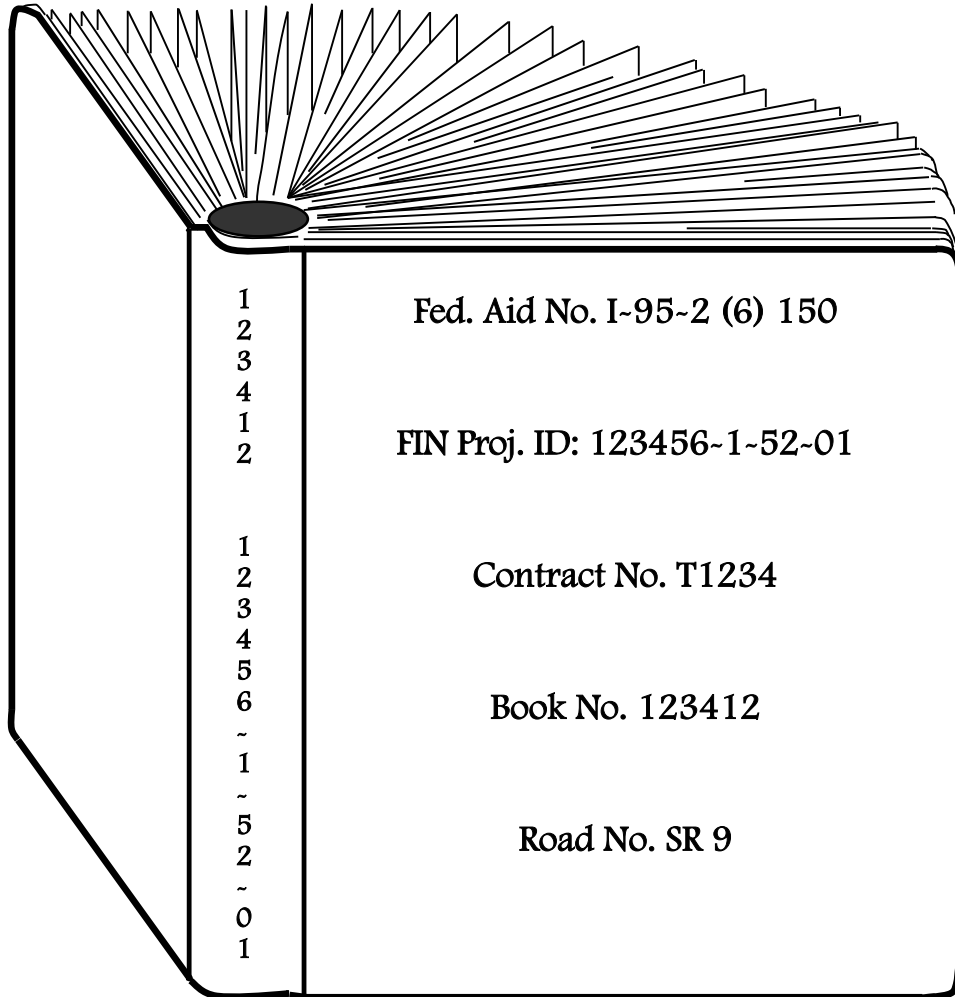

Attachment 5.14-2 BARGE DISPLACEMENT CALCULATION

BARGE WEIGHT CALCULATION EXAMPLE

Barge Material Delivery

	IN	Dec. 11, 1989
	OUT	Dec. 12, 1989

MATERIAL 300 - 5000
rubble rip rap

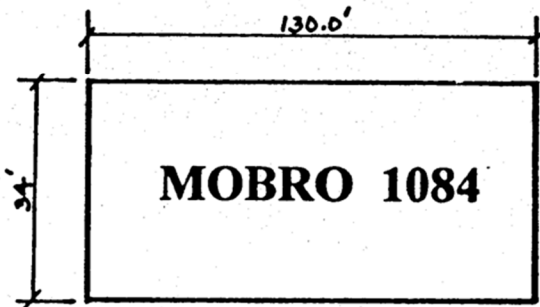
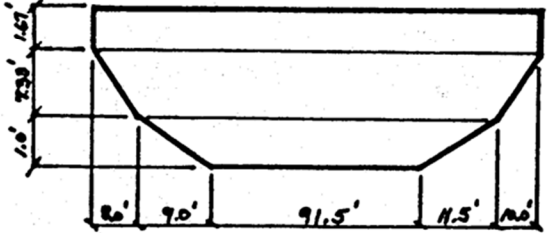
LOADED DRAFT

Port Forward	6.6
Port Aft	6.7
Starboard Forward	7.0
Starboard Aft	7.1
Average	6.85

LIGHT DRAFT

Port Forward	2.3
Port Aft	2.6
Starboard Forward	2.3
Starboard Aft	2.5
Average	2.43

Water line length at average loaded draft	126.36	
Water line length at average light draft	115.51	Bilge Correction
Net average water line length	120.94	-0-
Shape correction	-0-	Average
Average water line length	120.94	2.43

Average Difference in Light and Loaded Draft	4.42
--	------

Tonnage Computations: = 120.94' x 34' x 4.42' x [64(lb/cf)/2000(lb/ton)] =
 = 581.6 Tons

Note for unit weight of water: Sea Water = 64.0 lb/cf and Fresh Water = 62.4 lb/cf

Attachment 5.14-3 TOE WALL CALCULATION

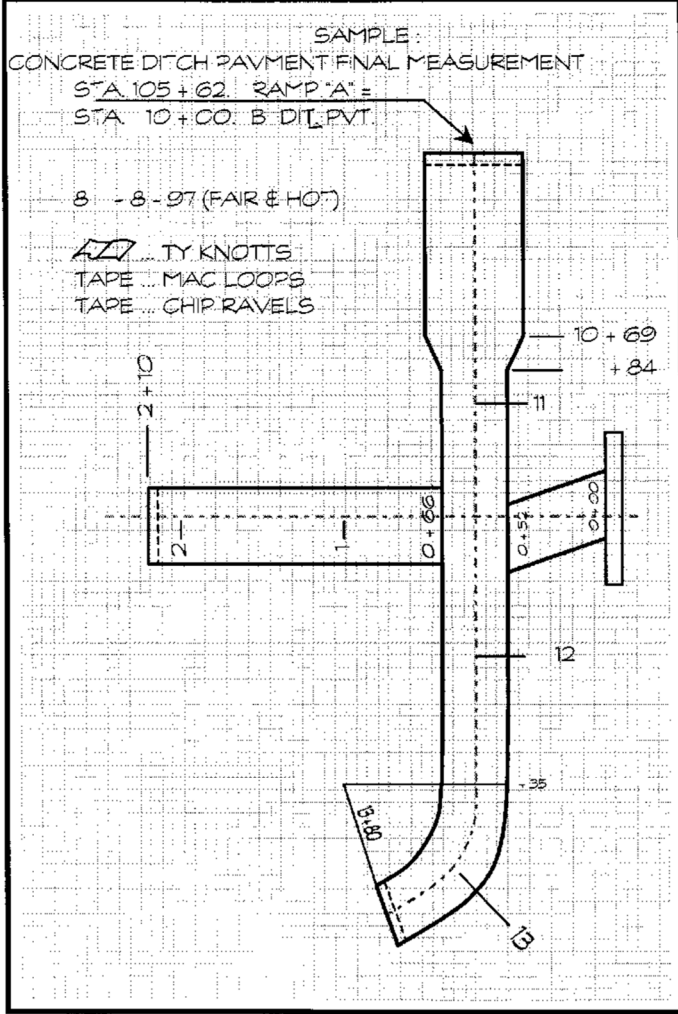

DITCH PAVT. LT. 105 + 62		DITCH PAVT. LT. RAMP 'A'	
STA	MEAS. 'M'	STA	MEAS. 'M'
0+00	39.2	10+00	20.2 W=8.5
-20	39.4	+50	20.0
+40	42.3	+69	20.1
+52	42.2 BK	+84	16.3
EXCEPTION			
+66	42.5 AH	11+00	16.1
+80	40.8	+50	16.2
1+00	41.0	12+00	16.3
+50	41.0	+35	16.9
+75	40.7	+50	17.0
2+00	40.5	3+00	17.3
+10	40.3 W=38.7	+50	17.2
	8,001.35 S.F.	+80	17.4 W=16.7
3.5 * 38.7 =	+135.45 S.F.		6,612.4 S.F.
	8,136.80 S.F.		+123.2 S.F.
			6,735.6 S.F.
		18.5	
		+6.7	
		3.5 * 35.2 =	123.2 S.F. (Toewalls)

MEASUREMENT 'M'
 IS ALONG THE SURFACE

VOLUME OF CONCRETE IN TOEWALLS ARE COMPUTED AS EQUIVALENT SQUARE FEET. IE, 6" thick + 3" increments = 2 x Height of toewall. (2 x 1.75' = 3.5' x 'W') = Equivalent S. F.

Attachment 5.14-4 DELIVERY TICKET



FLORIDA MINING & MATERIALS
 CONCRETE PRODUCTS
 LEE DIVISION
 P.O. BOX 2376, 2858 FORD STREET, FT. MYERS, FLORIDA 33902, PHONE (813)334-4521

Plant No. 03-004 Del. Ticket _____
 Serial No. _____
 Date: _____ 19 _____

Delivered To: _____
 Address _____

F.D.O.T. Fin. Proj. ID. _____

Truck No.	DOT Class	DOT Mix NO.	Cubic Yards This Load
Time Loaded	Arrived	Discharged	Cubic Yards Total Today
Allowable Jobsite Water Addition gals./cu. yd.		Mixing Revolutions: At Plant: At Jobsite:	
FILL OUT ON FIRST DELIVERY AND ON EACH CHANGE OF AGGREGATE WEIGHTS			
Cement _____ Brand Amount		Air MBVR _____ oz. Amount	
Course Agg. _____ % Moisture Amount		Retarder MBL-80 _____ oz. Amount	
Fine Agg. _____ % Moisture Amount		Fly Ash _____ Source Amount	
Batch Water (Gals.) _____ Amount		Coursr Agg. DOT Pit # _____ S.C. _____ Fine Agg. DOT Pit # _____ S.C. _____	

Issuance of this ticket constitutes certification to the accuracy of the above recorded information

Signature of Plant Operator or Company Rep.

WATER ADDED ON JOBSITE _____ GALLONS
 ADDITIONAL MIXING REVOLUTIONS _____

Attachment 5.14-5 SAMPLE SKETCH OF RIPRAP STRUCTURE

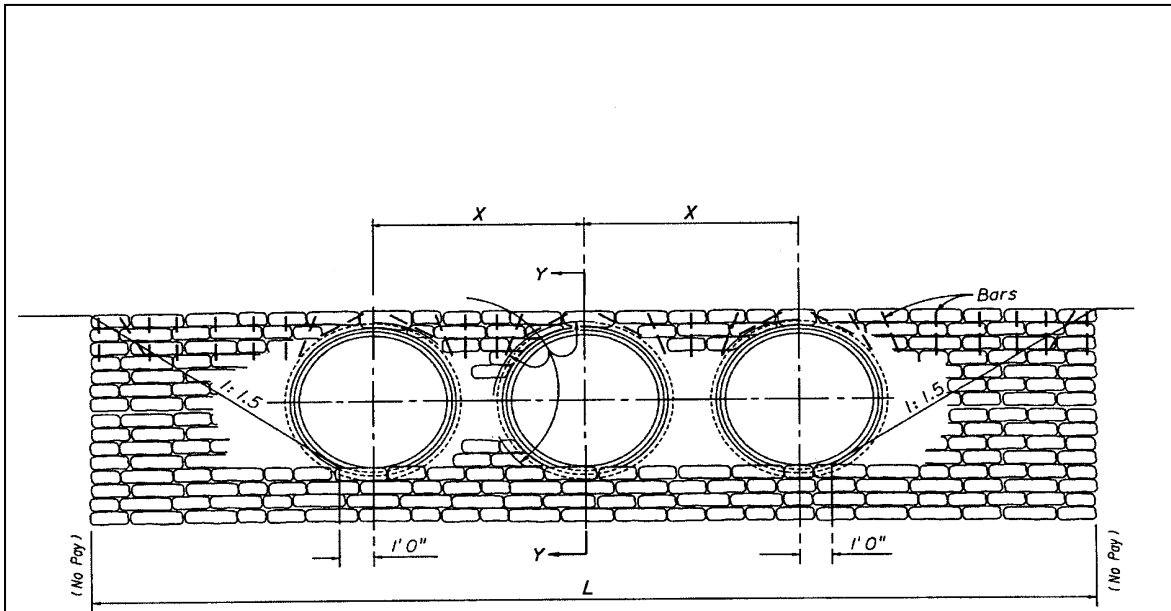

Note: Sketches must be submitted when pay is authorized outside limits as shown on the indexes. (No sketches will be required if built as per index).

- Example:**
- (1) Index No. 258 shows 31.1 cubic yards.
Delivery Tickets show 36.0 cubic yards.
We will pay _____ 31.1 cubic yards.

 - (2) Index No. 258 shows 31.1 cubic yards.
Delivery Tickets show 25.0 cubic yards.
We will pay _____ 25.0 cubic yards.

Attachment 5.14-6 SAND CEMENT RIPRAP PAY ANALYSIS

Step 1 STRUCTURE QUANTITY DETERMINATION	
Approved Quantity Dimension = 31.1 cu. yds.	
 Step 2 DELIVERY QUANTITY DETERMINATION	
Prebag ticket Delivery tickets	<u>Example</u> <u>Tally Book Summary</u>
Delivery tickets must be submitted showing the weights of sand & cement actually used for each delivery Ticket.	Jan. 9, 1990 = 8 cy = sand = 18,360 lbs. = cement = 4,064 lbs. Jan. 10, 1990 = 8 cy = sand = 18,360 lbs. = cement = 4,064 lbs. Jan. 11, 1990 = 8 cy = sand = 18,360 lbs. = cement = 4,064 lbs. Jan. 12, 1990 = 8 cy = sand = 18,360 lbs. = cement = 4,064 lbs. <u>32 cu. yds.</u>
<p>Note: Whichever is the lesser of Step 1 or Step 2 above, shall be paid. In the above example the structure quantity should be paid. If the delivery ticket quantity had been less than the structure quantity, the actual quantity delivered would have been paid.</p>	
Step 3 5:1 DETERMINATION	
<p>I. Computations to check for the actual ratio of the 5:1 mix : 18,360 lbs sand + 85 lbs/cf = 216 cf 4,064 lbs cement + 94 lbs/cf = 43.2 cf 216 + 43.2 = <u>5.0</u> , therefore this is a 5:1 mix, as required.</p> <p>II. CONSIDER: If the 5:1 mix had not been achieved, and the mix was allowed to be placed on the project, the following documentation is required: A. C-165 with negotiated pay reduction. B. Supplemental Agreement revising the unit price.</p>	

Attachment 5.14-7 CONTRACTOR'S CERTIFICATIONS OF QUANTITIES (FORM 700-050-66)

Contractor's Certification of Quantities Asphalt Mixes with Modified and Unmodified Binders (Conventional Projects) Certification No. <u>9</u>			
Financial Project ID: <u>654321-52-01</u>			
Contractor: <u>We Got Asphalt, Inc.</u>			
Contract Number: <u>X1234</u>			
From (Mo/Day/Yr): <u>01/16/17</u>		To (Mo/Day/Yr): <u>02/19/17</u>	
Asphalt Mixes with Unmodified Binders (PG 67 & Lower)			
Pay Item Number: <u>334-1-13</u>	Tonnage Placed: <u>341.4</u>		
Pay Item Number: _____	Tonnage Placed: _____		
Pay Item Number: _____	Tonnage Placed: _____		
Additional Gallons (ARM*): _____			
Base Index Month: <u>May-15</u>	Base Asphalt Price Index: <u>1.9365</u>		
Current Index Month: <u>Feb-17</u>	Current Asphalt Price Index: <u>1.8230</u>		
		Asphalt Index Difference: <u>-0.0167</u>	
Asphalt Mixes with Modified Binders (PG 76 & Higher)			
Pay Item Number: _____	Tonnage Placed: <input style="border: 1px solid green;" type="text"/>		
Pay Item Number: _____	Tonnage Placed: _____		
Pay Item Number: _____	Tonnage Placed: _____		
Base Index Month: _____	Base Polymer Price Index: _____		
Current Index Month: _____	Current Polymer Price Index: _____		
		Polymer Index Difference: _____	
Asphalt Material (ASPHALT TREATED PERMEABLE BASE)			
Pay Item Number: _____	Tonnage Placed: _____		
Base Index Month: _____	Base Asphalt Price Index: _____		
Current Index Month: _____	Current Asphalt Price Index: _____		
		Asphalt Index Difference: _____	
Navigation and Printing Functions			
<input type="button" value="Go To Main Sheet"/>		<input type="button" value="Go To Last Month Sheet"/>	
<input type="button" value="Save As Month Sheet"/>		<input type="button" value="Remove Last Month Sheet"/>	
<small>Effective January 2007 Letting FORM: 700-050-66 (7/21/2015)</small>			

EXAMPLE OF A CONTRACTOR'S CERTIFICATION OF QUANTITIES (FORM 700-050-66) Continued

STATE OF FLORIDA, DEPARTMENT OF TRANSPORTATION		FORM 700-050-66 CONSTRUCTION 02/17	
CONTRACTOR'S CERTIFICATION OF QUANTITIES ASPHALT MIXES WITH MODIFIED AND UNMODIFIED BINDERS (CONVENTIONAL PROJECTS)			CERTIFICATION NO.
			<u>9</u>
FINANCIAL PROJECT ID:	<u>654321-52-01</u>		
CONTRACTOR	<u>We Got Asphalt, Inc.</u>		
CONTRACT NO.	<u>X1234</u>		
PERIOD REPRESENTED BY CERTIFICATION:			
FROM (MO/DAY/YR)	<u>01/16/17</u>	TO (MO/DAY/YR)	<u>02/19/17</u>
ASPHALT MIXES WITH UNMODIFIED BINDERS (PG 67 & LOWER)			
BASE PRICE INDEX:	<u>1.9385</u>	CURRENT PRICE INDEX:	<u>1.8230</u> INDEX DIFFERENCE: <u>-0.0167</u>
	TONNAGE	GALLONS	MONTHLY PAYMENT
PAY ITEM NUMBER:	<u>334-1-13</u>	<u>341.4</u>	<u>4,974</u>
PAY ITEM NUMBER:			
PAY ITEM NUMBER:			
GALLONS OF ASPHALT CEMENT USED IN MIX: *		<u>4,974</u>	<u>-\$83.07</u>
ADDITIONAL GALLONS (ARMI):			
TOTAL GALLONS:		<u>4,974</u>	
TOTAL MONTHLY PAYMENT:			<u>-\$83.07</u>
ASPHALT MIXES WITH MODIFIED BINDERS (PG 76 & HIGHER)			
BASE PRICE INDEX:		CURRENT PRICE INDEX:	
		INDEX DIFFERENCE:	
	TONNAGE	GALLONS	MONTHLY PAYMENT
PAY ITEM NUMBER:			
PAY ITEM NUMBER:			
PAY ITEM NUMBER:			
TOTAL GALLONS OF POLYMER USED IN MIX: *			
TOTAL MONTHLY PAYMENT:			
ASPHALT MATERIAL (ASPHALT TREATED PERMEABLE BASE)			
BASE PRICE INDEX:		CURRENT PRICE INDEX:	
		INDEX DIFFERENCE:	
	TONNAGE	GALLONS	MONTHLY PAYMENT
PAY ITEM NUMBER:			
TOTAL MONTHLY PAYMENT:			
I certify that, based on my personal knowledge and well-founded belief following my own reasonable investigation, the tons and gallons (metric tons and liters) represented by this Certification are true and correct.			
 Contractor's Authorized Agent		Name of Company and email address	