

*State of Florida*  
*Department of Transportation*



**CADD Manual**  
(Production Criteria)

TOPIC NUMBER: 625-050-001  
Effective Date: October 1, 2015  
Update Date: February 9, 2016



ENGINEERING / CADD SYSTEMS OFFICE  
TALLAHASSEE, FLORIDA  
<http://www.dot.state.fl.us/ecso/>

*[THIS PAGE INTENTIONALLY LEFT BLANK]*

# Contents

<b>CHAPTER 1</b> .....	<b>1-1</b>
<b>INTRODUCTION</b> .....	<b>1-1</b>
1.1 PURPOSE.....	1-1
1.2 AUTHORITY .....	1-1
1.3 SCOPE .....	1-1
1.4 DEFINITIONS .....	1-1
1.5 ORGANIZATION.....	1-2
1.6 REFERENCES.....	1-2
1.7 REVISIONS AND ADDITIONS .....	1-3
1.7.1 CADD Manager Responsibility.....	1-3
1.7.2 CADD TAC Responsibility .....	1-3
1.8 DISTRIBUTION .....	1-3
1.9 TRAINING .....	1-3
1.10 FORMS.....	1-3
<b>CHAPTER 2</b> .....	<b>2-1</b>
<b>COMPUTER SYSTEMS</b> .....	<b>2-1</b>
2.1 PURPOSE.....	2-1
2.2 SCOPE .....	2-1
2.3 DEFINITIONS .....	2-1
2.4 REFERENCES.....	2-1
2.5 PROCUREMENT OF CADD HARDWARE AND SOFTWARE .....	2-1
<b>CHAPTER 3</b> .....	<b>3-1</b>
<b>CADD PRODUCTION STANDARDS</b> .....	<b>3-1</b>
3.1 PURPOSE.....	3-1
3.2 SCOPE .....	3-1
3.3 DEFINITIONS .....	3-1
3.4 REFERENCES.....	3-3
3.5 CADD RESOURCE AND SUPPORT FILES.....	3-3
3.5.1 Supporting Database Resources.....	3-4
3.5.2 Seed / Template Files.....	3-4
3.5.2.1 MicroStation Seed Files.....	3-4
3.5.2.2 AutoCAD Template Files .....	3-4
3.6 CADD STANDARD RULES .....	3-5
3.7 LEVELS / LAYERS AND SYMBOLOGY .....	3-6
3.7.1 Levels and Layers.....	3-7

3.7.2 Color .....	3-8
3.7.3 Line Weight.....	3-9
3.7.4 Line Styles / Linetypes.....	3-10
3.7.4.1 Custom Line Styles .....	3-11
3.8 CELL LIBRARIES / BLOCK DRAWINGS .....	3-16
3.9 TEXT .....	3-18
3.9.1 True Type Fonts (TTF) .....	3-18
3.9.2 Text Size and Spacing .....	3-19
3.10 MICROSTATION PRINT RESOURCE FILES .....	3-19
3.11 AutoCAD/Civil 3D PRINT RESOURCE FILES .....	3-20
<b>CHAPTER 4.....</b>	<b>4-1</b>
<b>CADD PRODUCTION PROCEDURES.....</b>	<b>4-1</b>
4.1 PURPOSE.....	4-1
4.2 SCOPE .....	4-1
4.3 ACCOUNTABILITY.....	4-1
4.4 DEFINITIONS .....	4-1
4.5 REFERENCES.....	4-3
4.6 CADD RESOURCES.....	4-3
4.7 STANDARD PROJECT FOLDER.....	4-3
4.7.1 Create Project.....	4-3
4.7.2 Standard Project Folder Structure .....	4-3
4.7.2.1 Calculations Project Folder .....	4-5
4.7.2.2 Discipline Sub-Folders .....	4-5
4.8 STANDARD FILE NAMES .....	4-6
4.8.1 Standard Design File Naming Convention .....	4-6
4.8.2 Print Image File Naming Convention.....	4-7
4.8.2.1 Sheet Numbers .....	4-7
4.8.2.2 Print Image File Naming Format .....	4-8
4.8.3 Typical File Name Extensions.....	4-9
4.8.4 Duplicate Files .....	4-10
4.9 REFERENCE FILES .....	4-10
4.10 SHARING CADD FILES BETWEEN DISCIPLINES .....	4-11
4.11 PROJECT JOURNAL.....	4-12
4.12 PRINTS .....	4-12
4.12.1 Print Borders.....	4-12
4.12.2 Print Image Files.....	4-12
4.12.3 Foreign Plan Sheets.....	4-13

4.12.4 Print Drivers.....	4-13
4.12.4.1 MicroStation Half-Toning.....	4-13
4.12.4.2 Quality and Reproduction.....	4-13
4.12.5 Professional of Record Note.....	4-14
4.13 RIGHT OF WAY (R/W) MAPPING STANDARDS.....	4-15
4.13.1 Standard File Names.....	4-15
4.13.2 R/W Cell Library.....	4-16
4.13.3 Level / Layer and Symbology Standards.....	4-18
4.13.4 R/W Workspace.....	4-18
4.14 ENVIRONMENTAL MANAGEMENT STANDARDS.....	4-18
4.14.1 Standard File Names.....	4-18
4.15 SURVEY STANDARDS.....	4-21
4.15.1 Level/Layer and Symbology Standards.....	4-21
4.15.2 Standard File Names.....	4-21
4.15.3 Data Files Created by Survey.....	4-22
4.15.4 Resource Files.....	4-22
4.15.5 GEOPAK Survey.....	4-24
4.15.6 AutoCAD Civil 3D.....	4-24
4.15.7 Survey Data.....	4-24
4.15.8 County Mapping.....	4-25
4.16 DRAINAGE STANDARDS.....	4-29
4.16.1 Standard File Names.....	4-29
4.16.2 File Sharing and Merging.....	4-30
4.16.3 Resource Files.....	4-30
4.16.4 Engineering Data.....	4-30
4.16.5 Packaging.....	4-30
4.17 ROADWAY STANDARDS.....	4-31
4.17.1 Standard File Names.....	4-31
4.17.2 Engineering Data.....	4-33
4.18 SIGNING & PAVEMENT MARKING STANDARDS.....	4-34
4.18.1 Standard File Names.....	4-34
4.18.2 Sign Design.....	4-35
4.18.3 GuidSIGN.....	4-35
4.18.4 AutoTURN.....	4-35
4.19 SIGNALS STANDARDS.....	4-36
4.19.1 Standard File Names.....	4-36

4.20 HIGHWAY LIGHTING STANDARDS .....	4-37
4.20.1 Standard File Names .....	4-37
4.20.2 AGI32 Lighting Software .....	4-38
4.21 LANDSCAPE STANDARDS .....	4-38
4.21.1 Standard File Names .....	4-39
4.22 STRUCTURES STANDARDS .....	4-40
4.22.1 Standard File Names .....	4-40
4.22.2 Resource Files .....	4-47
4.22.3 Engineering Data.....	4-48
4.22.4 Level and Symbology Standards.....	4-48
4.22.5 Borders and Scales .....	4-49
4.22.5.1 Borders: .....	4-49
4.22.5.2 Scales: .....	4-49
4.22.6 Text Sizes and Weights.....	4-50
4.22.7 Colors.....	4-51
4.22.8 Special Symbols .....	4-51
4.22.9 Dimension Settings.....	4-51
4.22.10 Reference Files .....	4-51
4.22.11 Existing Bridge Plans .....	4-51
4.23 UTILITIES STANDARDS .....	4-52
4.23.1 Utility File Coordination Options .....	4-52
4.23.2 Utility Coordination .....	4-52
4.23.3 Exchange of Design Files .....	4-54
4.23.4 Standard File Names .....	4-54
4.23.5 Utility Work by Highway Contractor Agreement Plans .....	4-55
4.23.6 ASCII Files of Utility Data .....	4-56
4.23.7 Utility Scanned Images.....	4-56
4.24 GEOTECHNICAL STANDARDS .....	4-57
4.24.1 Standard File Names .....	4-57
4.24.2 Engineering Data.....	4-58
4.24.3 Soil Survey .....	4-58
4.24.4 Soil Boring Data.....	4-58
4.25 CONSTRUCTION STANDARDS .....	4-59
4.25.1 Standard File Names .....	4-59
4.26 INTELLIGENT TRANSPORTATION SYSTEMS STANDARDS .....	4-60
4.26.1 Standard File Names .....	4-60

4.27 ARCHITECTURAL STANDARDS.....	4-61
4.27.1 Adopted CADD File Format.....	4-61
4.27.2 Adopted CADD Standards.....	4-62
4.27.3 Architectural Projects.....	4-62
4.27.4 Delineation between Architectural & Engineering Plans .....	4-63
4.27.5 Standard File Names .....	4-64
4.27.6 Standard Sheet File Names .....	4-65
4.27.7 Engineering Data.....	4-67
4.27.8 Layers and Symbology.....	4-67
4.27.9 Architectural Scale Chart.....	4-68
4.27.10 Text Type, Size and Line Weight.....	4-68
4.27.11 Layer Names .....	4-70
4.27.12 File Structure .....	4-70
4.27.13 Signing and Sealing.....	4-70
4.27.14 Submittal.....	4-70
4.28 SPECIFICATION STANDARDS.....	4-71
4.28.1 Standard File Names .....	4-71
4.28.2 Resource Files.....	4-71
4.28.3 Technical Special Provisions .....	4-71
4.28.4 File Structure (Specs Only Projects) .....	4-72
<b>CHAPTER 5.....</b>	<b>5-1</b>
<b>DELIVERY PROCEDURE.....</b>	<b>5-1</b>
5.1 PURPOSE.....	5-1
5.2 SCOPE .....	5-1
5.3 DEFINITIONS .....	5-1
5.4 REFERENCES.....	5-3
5.5 RECEIPT AND ACCEPTANCE OF ELECTRONIC DATA .....	5-4
5.6 ENGINEERING DATA SERVICES.....	5-4
5.7 PUBLICATION AND DISTRIBUTION .....	5-4
5.8 DIGITAL DELIVERY .....	5-4
5.8.1 Production Deliverable Files .....	5-5
5.9 PRE-PRODUCTION.....	5-9
5.10 PRODUCTION.....	5-10
5.10.1 fpid-PLANS.PDF File and Plans Component PDFs .....	5-10
5.10.1.1 Early Work Sheets of Plan Sets .....	5-11

5.10.2 Engineering Data.....	5-12
5.10.2.1 Delivery Standards for Engineering Data .....	5-13
5.10.2.2 Cross Sections .....	5-13
5.10.2.3 Quantity Files .....	5-13
5.10.3 3D Deliverables - Data for Machine Control in Construction .....	5-13
5.10.3.1 Types of Modeling Data Needed .....	5-14
5.10.3.2 3D Deliverables Supporting AMG for 3D Designed Projects .....	5-15
5.10.3.3 Maximum Corridor Frequency Interval Spacing for 3D Design .....	5-16
5.10.3.4 Quality Control of Corridor Models and Extracted Surface .....	5-17
5.10.4 Merging External Project Files.....	5-18
5.10.4.1 CADD System Dependency Files: .....	5-18
5.10.4.2 Files from Outside Sources: .....	5-18
5.10.4.3 Merging Previously Digitally Signed Documents:.....	5-18
5.10.5 Reviewing the Project.....	5-18
5.10.6 Sign and Seal Project Files .....	5-19
5.10.6.1 Digital Certificates.....	5-20
5.10.6.2 Managing Digital Certificates .....	5-20
5.10.6.3 Multiple Signature Sheets.....	5-20
5.10.6.4 Securing the Project for Delivery .....	5-20
5.10.7 Legacy Electronic Signature Projects.....	5-21
5.10.8 Media Requirements for Delivery.....	5-21
5.10.9 Compliance Certification Checklist Report .....	5-22
5.11 POST-PRODUCTION .....	5-23
5.12 REVISIONS.....	5-23
5.13 STRUNG PROJECTS.....	5-23
5.14 RE-LET PROJECTS AND ROLL BACK REVISIONS .....	5-24
5.15 DESIGN BUILD PROJECTS .....	5-24
<b>CHAPTER 6.....</b>	<b>6-1</b>
<b>SUPPORT .....</b>	<b>6-1</b>
6.1 PURPOSE.....	6-1
6.2 SCOPE .....	6-1
6.3 REFERENCES.....	6-1
6.4 COMPONENTS OF CADD SUPPORT .....	6-1
6.4.1 Systems Support .....	6-1
6.4.2 Operational Support.....	6-1
6.4.3 Training .....	6-2



6.5 HIERARCHY OF CADD SUPPORT .....	6-2
6.5.1 Systems Support .....	6-2
6.5.2 Operational Support .....	6-3
6.5.3 Training Support .....	6-3
<b>CHAPTER 7 .....</b>	<b>7-1</b>
<b>SOFTWARE DEVELOPMENT AND DISTRIBUTION .....</b>	<b>7-1</b>
7.1 PURPOSE .....	7-1
7.2 SCOPE .....	7-1
7.3 DEFINITIONS .....	7-1
7.4 DEVELOPMENT .....	7-1
7.4.1 Development or Acquisition .....	7-1
7.5 SOFTWARE UPDATES .....	7-2
7.6 SOFTWARE TESTING .....	7-2
7.7 TAC REVIEW AND RECOMMENDATION .....	7-2
7.8 CADD PRODUCT APPROVAL AND DISTRIBUTION .....	7-2
7.9 MINIMUM SYSTEM REQUIREMENTS .....	7-3
7.10 TRANSLATION OF FILES .....	7-3
<b>CHAPTER 8 .....</b>	<b>8-1</b>
<b>QUALITY ASSURANCE .....</b>	<b>8-1</b>
8.1 PURPOSE .....	8-1
8.2 AUTHORITY .....	8-1
8.3 SCOPE .....	8-1
8.4 REFERENCES .....	8-1
8.5 DEFINITIONS .....	8-2
8.6 QA MONITORING PLAN .....	8-2
8.7 ACCOUNTABILITY .....	8-2
8.8 QUALITY ASSURANCE (QA) REVIEWS .....	8-2
8.9 QUALITY CONTROL (QC) – DATA PRODUCERS’ ROLE .....	8-3
8.10 QUALITY ASSURANCE (QA) – CENTRAL OFFICE ROLE .....	8-3

*[THIS PAGE INTENTIONALLY LEFT BLANK]*

# Chapter 1

## INTRODUCTION

### 1.1 PURPOSE

The *CADD Manual* addresses the requirement to utilize Computer Aided Design and Drafting (CADD) for production and delivery of digital project data for the Florida Department of Transportation (Department). In addition to software and configuration requirements, it identifies tools, techniques, applications, standards and procedures that are used to produce a consistent and quality CADD product for the Department.

The *CADD Manual* establishes *minimum* CADD standards to ensure a consistent, predictable and repeatable CADD data set for Department's projects. The *CADD Manual* also serves to provide professional services administrators, project managers, consultants, in-house designers, and others a procedure to be incorporated by reference into scopes and other contract documents for services.

### 1.2 AUTHORITY

[Subsection 20.23\(4\) \(a\), Florida Statutes \(F.S.\)](#)

[Section 334.048\(3\) Legislative Intent to Department Management Accountability and Monitoring Systems, Florida Statutes \(F.S.\)](#)

### 1.3 SCOPE

The *CADD Manual* is to be used by all personnel producing projects utilizing CADD for the Department. It is to be referenced in contracts requiring engineering plans preparation utilizing CADD. This manual affects all offices of the Department and all consultants, contractors and others who utilize CADD applications. The Districts are monitored for critical requirement to meet the Department's CADD Quality Assurance objectives.

### 1.4 DEFINITIONS

**CADD** - (Acronym for Computer Aided Design and Drafting) Software and methods used to design and represent objects graphically on the computer. CADD facilitates the visual presentation of Engineering Data.

**Statewide CADD Coordinator** – Individual in the Central Office responsible for coordinating amongst the Districts to implement a uniform policy and standards for CADD operations for the Department.

**CADD Manager** - The CADD Manager is responsible for (1) support of the core CADD software products in the work units and (2) a variety of engineering data services functions including but not limited to the receipt, acceptance, and management of digital deliveries of project data.

**CADD Support** - The technical and operational activity necessary to ensure that a production environment is maintained, which includes:

- a) Selection, development and distribution of production CADD software, related procedures, criteria and standard operating instructions,
- b) Provision of training opportunities for CADD users,
- c) Management of design data produced with the CADD software,
- d) Statewide procurement of: CADD software, training services, and software development assistance.

**CADD TAC** - (Acronym for Technical Advisory Committee) A discipline-based group sanctioned by the Statewide CADD Coordinator consisting of District and Central Office representatives charged to meet and work on statewide technical issues dealing with CADD applications, procedures, testing, training, and implementation.

**Engineering Data** - Those digital files which support or represent the intent of the engineering design.

## 1.5 ORGANIZATION

The Department's Engineering / CADD Systems Office (ECSO), with input from the districts and industry, will develop and maintain procedures and standards for the Department's CADD production and related activities.

The following chapters are included:

**Chapter 1 Introduction:** Describes and implements the *CADD Manual*.

**Chapter 2 Computer Systems:** Establishes the minimum requirements for procurement, maintenance and technical support of the Department's CADD systems.

**Chapter 3 CADD Production Standards:** Defines the critical CADD Production Standards to be used in the production of the Department's CADD projects.

**Chapter 4 CADD Production Procedures:** Establishes minimum requirements for the production of the Department's CADD projects in accordance with the Department's plans preparation procedures and practices.

**Chapter 5 Delivery Procedure:** Establishes the minimum requirements and functions necessary for the Department's CADD delivery, describing how electronic data is to be delivered, archived and made available to customers.

**Chapter 6 Support:** Establishes the primary components of the Department's CADD support structure and services, including the statewide training, and defines applications and tools supported by the ECSO.

**Chapter 7 Software Development and Distribution:** Establishes how the Department's CADD software is developed, tested, approved and distributed.

**Chapter 8 Quality Assurance:** Establishes the bases for Quality Assurance (QA) monitoring of the Department's District CADD functions, including the areas of responsibility, frequency of monitoring and reporting methods.

## 1.6 REFERENCES

[Florida Administrative Code, Chapter 1B-26.003\(10\)](#)

This document provides standards for record (master) copies of public records which reside in electronic recordkeeping systems.

[Information Technology Resource User's Manual, Topic No. 325-000-002](#)

This document contains the standards and guidelines related to information technology resources.

## 1.7 REVISIONS AND ADDITIONS

*CADD Manual* holders are encouraged to submit comments and suggestions for improvements to this manual. The Suggestion and Comment sheet at the end of this chapter or the ECSO email link listed on the sheet may be used to provide feedback. All proposed revisions and additions, either in draft or final form, must be reviewed by all offices affected by the Manual.

Chapter 1 of this manual is the only chapter subject to the Executive Review Process. This chapter authorizes the development and implementation of the *CADD Manual*. The remaining chapters will be updated and approved by the Statewide CADD Coordinator with input from the Districts and offices within the Central Office that may be affected. The intent is to be able to make technical revisions to the manual in a timely manner. Substantive revisions that result in policy change must be coordinated with the Executive Committee *in* accordance with *Procedure No. 025-020-002, Standard Operating System*.

All revisions and updates must be coordinated with the Forms and Procedures Office prior to distribution to ensure conformance with and incorporation into the Department's Standard Operating System.

### 1.7.1 CADD Manager Responsibility

District CADD Managers must interface between the users of CADD and the ECSO to facilitate input, revisions and additions to this manual. It is the CADD Manager's responsibility to ensure that all offices affected by this manual are informed of the Department's CADD policies, procedures, and standards. The CADD Manager must forward District recommendations for changes to CADD policies, procedures, and standards to the Statewide CADD Coordinator for consideration and processing through the CADD TACs.

### 1.7.2 CADD TAC Responsibility

Disciplines utilizing CADD are represented by a CADD TAC. Each District and the Central Office are represented on the TACs by knowledgeable and proficient CADD users. The purpose of these TACs is to continually improve the CADD procedures, process, standards, and identify users' needs. End User and CADD Manager Input for revisions and additions to the *CADD Manual* are processed through the TACs. The chairperson must forward committee recommendations to the Statewide CADD Coordinator and copy the District CADD Manager.

## 1.8 DISTRIBUTION

The *CADD Manual* is distributed in electronic form and may be downloaded from the ECSO website:

<http://www.dot.state.fl.us/ecso/downloads/publications/publications.shtm>

## 1.9 TRAINING

Training issues and opportunities are identified within the applicable chapters.

## 1.10 FORMS

Forms required for use with this manual are identified at the end of each chapter where applicable.



# Chapter 2

## COMPUTER SYSTEMS

### 2.1 PURPOSE

This chapter establishes the minimum requirements for procurement, maintenance and technical support of the Florida Department of Transportation (Department's) Computer Aided Design and Drafting (CADD) systems.

### 2.2 SCOPE

These requirements apply to all computer technology and services within the responsibility of the Engineering / CADD Systems Office (ECSO), the CADD Managers of each District, Office of Information Technology (OIT), and Information Technology (IT) personnel assigned to support the CADD program.

### 2.3 DEFINITIONS

**CADD Hardware:** The workstations, servers, printers and all other computer equipment used in the Department's design production effort.

**CADD Software:** Any software procured, developed, distributed and supported by ECSO.

**OIT Personnel Supporting CADD:** OIT personnel assigned to support the CADD program to perform the role of management and related tasks of the Department's IT infrastructure.

### 2.4 REFERENCES

[Information Technology Resource User's Manual, Topic No. 325-000-002](#)

This document contains the standards, guidelines, and requirements related to information technology resources.

### 2.5 PROCUREMENT OF CADD HARDWARE AND SOFTWARE

The CADD Managers and OIT personnel evaluate the needs for computer hardware to provide recommendations for procurement of any of the Department's CADD hardware where appropriate, and do so in accordance with *Information Technology Resource User's Manual, Topic No. 325-000-002*. The ECSO participates with OIT in the development of the Information Technology Resource Standards and evaluation of hardware to be procured for use in CADD.

The ECSO, in conjunction with the Technical Advisory Committees (TACs) and CADD Managers, review the statewide CADD software needs to support the Department's production efforts.

*[THIS PAGE INTENTIONALLY LEFT BLANK]*



# Chapter 3

## CADD PRODUCTION STANDARDS

### 3.1 PURPOSE

This chapter defines the Florida Department of Transportation (Department's) critical Computer Aided Design & Drafting (CADD) Production Standards to be used in the production of the Department's CADD projects.

### 3.2 SCOPE

These Production Standards apply to all projects produced by and for the Department using CADD in addition to the criteria, standards and procedures of the various disciplines within the Department.

### 3.3 DEFINITIONS

The following definitions relate to electronically generated project data and deliverables. For the definition of other common terms and acronyms used in this Manual, refer to the respective Chapters.

**ByLayer (Civil 3D)**– A property that, when turned on, causes the object on a particular layer to retrieve its definition from the Layer Properties of that layer, such as Color, Linetype, and Line weight.

**ByLevel (MicroStation)**– A setting that, when turned on, causes the element on a particular level to retrieve its definition from the Level Symbolology of that layer, such as Color, Line Style, and Line Weight defined by the Level Symbolology.

**Component** – A categorization of design plans as defined in Chapters 2 & 3 of the Department's *Plans Preparation Manual (PPM)*, Volume 2. The list of plans components for Digital Delivery is comprised of the following:

1. Roadway Plans
2. Signing and Pavement Marking Plans
3. Signalization Plans
4. Intelligent Transportation System (ITS) Plans
5. Lighting Plans
6. Landscape Plans
7. Architectural Plans
8. Structures Plans
9. Toll Facilities Plans

The plans components do not directly correspond to the project's folder structure. For example, drainage files have a \drainage\ folder below the root level project folder, but might be included as part of the Roadway Plans Component.

**Design File** – An electronic CADD file that conforms to MicroStation® (DGN) or AutoCAD® (DWG) graphics formats.

**Drawing Units (Civil 3D)** – The real-world units used in a Civil 3D drawing that represents the measurement system used to construct the real world design, such as US Survey Feet.

**Font Library** – A file in which text characters styles, symbols, or patterns are stored.

- Global Origin (MicroStation)** – Origin location of the Cartesian coordinate system in the design plane coordinates (UORs) for MicroStation files. When design plane positions are specified or reported in working units, they are relative to the global origin.
- Layer Symbology (Civil 3D)** – The definition of the properties an object inherits when placed on a layer using the “ByLayer” property. The layer definition contains properties such as Color, Linetype, and Line weight.
- Level / Layer** – Data in the design file segregated into drawing levels or layers.
- Level Symbology (MicroStation)** – The definition of the symbology an element inherits when placed on a level using the “ByLevel” setting. The level definition contains symbology such as Color, Line Style, and Line Weight
- Line Style (MicroStation)** – Part of the symbology of an element: for example, whether a line is represented a solid or continuous, composed of dashes, dots and dashes, and so on. Each element has its own line style.
- Line Weight (MicroStation)** – An index that designates the thickness of the lines used to draw or print a graphic element. Each element has its own line weight.
- Linetype (Civil 3D)** – Part of the property of an object: for example, whether a line is represented by a continuous line or a series of dots and/or dashes and spaces.
- Line weight (Civil 3D)** – The thickness of a line used for display or print purposes defined in millimeters.
- Master Units (MicroStation)** – The largest unit in common use in a design file, usually represented in US Survey Feet for most of the Department’s seed files.
- Project Folder** – The parent or “root” folder for a project containing all of the project’s subfolders and files.
- Properties (Civil 3D)** – The settings applied to an element for visualization/printing purposes, such as Color, Linetype, Line weight, Transparency, etcetera.
- Supporting CADD Files** – Any file, including Resource Files (such as fonts, line styles, pen tables, cell / block libraries, etcetera.) required to produce the printable sheet images of a plan set.
- Symbol** – A character placed from a TrueType font, MicroStation font library, or AutoCAD font file.
- Symbology (MicroStation)** – The settings applied to an element for visualization/printing purposes, such as Color, Line Style, Line Weight, Transparency, etcetera.
- Text Attributes / Properties** – The color, weight, font, height and width of text.
- Text Element / Objects** – Text in (MicroStation / AutoCAD) design files as a distinct type of element.
- Units of Resolution (UORs) (MicroStation)** – The distance between adjacent points in a MicroStation design plane. There are a very large number of fixed discrete positions or UORs along each coordinate axis that are defined as real world coordinates by master units and sub-units (collectively, working units).
- Working Area (MicroStation)** – Size, in working units square, of design plane.
- Working Units (MicroStation)** – The real-world units in MicroStation that the design plane is configured to, such as US Survey Feet.

### 3.4 REFERENCES

**[Plans Preparation Manual Volume 1 & 2, Topic Nos. 625-000-007 / 625-000-008](#)**

This manual provides engineering criteria and guidelines to be used in the development of Roadway designs and plans preparation for roads on the State Highway System.

**[Facilities Design Manual \(Topic No. 625-020-016\)](#)**

This manual describes the Department's guidelines and requirements for providing professional Architectural / Engineering (A / E) consulting services for building facility projects for the Department.

**[Design Standards \(Topic No. 625-010-003\)](#)**

These indexes provide standard drawings to support the various engineering obligations for designing, specifying, estimating, constructing, inspecting, testing, accepting, operating, maintaining and monitoring the roads on the State Highway System including Standard Abbreviations.

**[Structures Manual \(Topic No. 625-020-018\)](#)**

This manual provides the structures personnel with guidelines for the development of uniform structural design and plans preparation.

### 3.5 CADD RESOURCE AND SUPPORT FILES

The Department develops CADD Standards for the production of Florida transportation facility plans to be delivered with the aid of the CADD Software Suite. The Engineering / CADD Systems Office (ECSO) manages and coordinates these CADD Standards through customizations within the Department's approved CADD software platforms and the tools contained in the CADD Software Suite.

The Department's CADD Software Suite includes standard design libraries / templates to propagate the CADD Standards definitions of levels / layers and symbology (color, line styles / linetypes, weights), multi-line styles, text styles, dimension styles, cells, element templates, menu customizations, customized tools, tool boxes, and tasks for both the Bentley GEOPAK and Autodesk Civil 3D platforms.

Projects will be maintained and updated with the latest available and supported software versions published on the Engineering/CADD Systems Office (ECSO) listed below. Exceptions must be approved by the Department's Project Manager and must be documented and delivered as part of the project.

**<http://www.dot.state.fl.us/ecso/main/Version/CurrentVersions.shtm>**

The Department's standard resources definitions for CADD drawings are consistent between the MicroStation and AutoCAD platforms. The following are examples of platform conventions:

<u>MicroStation</u>	<u>AutoCAD equivalent</u>
File name	File name
Level name	Layer name
Cell Library	Block Drawing
Cell name	Block name
Line Style	Linetype
Line Weight	Line weight
Color	Color
Seed file	Template file

## 3.5.1 Supporting Database Resources

For MicroStation projects the Department's CADD Software Suite includes a GEOPAK Design and Computation (D&C) Manager database file, *FDOTXXX.ddb*, located at *\FDOTXXX\geopak\databases\folder*. This database is set up specifically to create drawing elements and attach pay item data according to the Department's CADD Standards. Likewise, for AutoCAD Civil 3D projects, the *AECMerge.xml* file is delivered with the FDOTXXXX.C3D State Kit and serves a similar function. *AECMerge.xml* is located in the *\FDOTXXXX.C3D\Data\PayItemData\* folder.

**Note** 'XXX' or 'XXXX' represent the versioning of the Department's CADD Software Suite.

These resources may need to be modified for project specific items or to comply with District standards. If the GEOPAK D&C Manager *FDOTXXX.ddb* database is customized, the user must save a copy of this custom database into the project folder in the *\symp\* project sub-folder. Saving the database to the project folder is important to ensure the modified database will be delivered with the project. Likewise a modified copy of the Civil 3D *AECMerge.XML* file must be saved to the *\symp\* project sub-folder.

When modifying project specific database resources, the following naming convention must be used:

*Project Financial Project Identification Number[Discipline Designation].ddb*

Where *Discipline Designation* would be one of the following:

dr	(drainage)
it	(intelligent transportation system)
ld	(landscape)
lt	(lighting)
rd	(roadway)
sg	(signalization)
sp	(signing and pavement markings)
ut	(utilities)

Example: A modified standard DDB for signalization, *19728125201sg.ddb* would be stored in *\19728125201\symp\* subfolder of the aforementioned project.

## 3.5.2 Seed / Template Files

### 3.5.2.1 MicroStation Seed Files

MicroStation uses "seed" files to create all design files. Working units and global origin are two of the most important settings in the seed file. Working units are expressed as master units and sub-units. All standard seed files for MicroStation have been defined based on a master unit of "Survey Feet" with a sub unit of "Survey Inches." The global origin is located at the center of the design plane for all seed files.

The resolution in MicroStation files is defined per the master unit and determines the size (working area) of the design plane, which must encompass an area large enough for any State Plane coordinate zone in Florida. The resolution is set to 304800 units of resolution (UORs) per Survey Foot.

Set the geographic coordinate system to the appropriate Florida State Plane Zone in production drawings derived from the seed files.

### 3.5.2.2 AutoCAD Template Files

AutoCAD also uses "template" files to create design files. Drawing units are also US Survey Feet and the geographic coordinate system for production drawings derived from templates must be set for the project's State Plane Zone. Templates are style based AutoCAD drawings.

### 3.6 CADD STANDARD RULES

The Department’s level / symbology standards for projects define standard Level / Layer names with specific “ByLevel” Color, Style / Linetype and Weight Symbology for graphic elements for both the Bentley and Autodesk platforms. In nearly every instance, the names for Level / Layer, Color, Style / Linetype, etcetera. are the same between the platforms for consistency. These level / symbology CADD standards are grouped to define specific CADD standard “rules” which are associated with each of the Department’s CADD standard filenames. These rules are defined related to a given discipline, or purpose for the file.

**Note** The individual Discipline sections found in Chapter 4 of this Manual provide a comprehensive listings of respective CADD standard filenames with the associated CADD standard rule.

These CADD standard rules facilitate the Quality Control (QC) software to check each of the standard project’s design files for compliancy to the specification found in these rules.

➤ **The Department’s CADD Standard Rules & Descriptions:**

**Note** Appendix A has a comprehensive listing of the Department’s CADD standard rules and the associated CADD standard levels and symbology.

Standard Rule	Description	Standard Rule	Description
alnrd	Alignment Design	keysht	Key Sheets
autosp	AutoTURN	msarsp	Mast Arm Details
cliprd	Clip Border	open	All Levels and Symbology Accepted
drdtrd	Drainage Detail	pdxsrd	Pond Cross Section
drexrd	Drainage Existing	planrd	Roadway Plan Sheet
drmprd	Drainage Map	plprrd	Roadway Plan / Profile Sheet
drprrd	Drainage Proposed	qtdsrd	Quantity Computation
drxsrd	Drainage Cross Section	rdxsrd	Roadway Cross Section
dsgnld	Landscaping Design	rdxssp	Signing & Pavement Cross Section
dsgnlt	Lighting Design	rwtdrd	Right of Way Detail for Roadway
dsgnrd	Roadway Design	rweng10	Right of Way
dsgnsg	Signalization Design	spst10	Structural
dsgnsp	Signing & Pavement Marking Design	survrd	Survey Development Model
dtmrd	Digital Terrain (Proposed)	tcdsrd	Traffic Control
gdtmrd	Digital Terrain (Existing)	topord	Existing Topography for Roadway
geotech	Geotechnical	typdrd	Typical Section Data
gswksp	GuidSIGN	utadrd	Utilities Adjustment
irrgld	Irrigation	utexrd	Utilities Existing
itssp	Intelligent Transportation System	utprrd	Utilities Proposed

### 3.7 LEVELS / LAYERS AND SYMBOLOGY

The Department’s CADD Software Suite includes standard design libraries / templates to propagate the CADD standards definitions of levels / layers and symbology (color, line styles / linetypes, weights). The libraries for MicroStation are located in the \FDOTXXX\RESOURCES\dgnlibs\ folder and the templates for AutoCAD Civil 3D are located in the FDOTXXXX.C3D\Data\Templates\ folder.

The Department’s CADD Software Suite also includes a Microsoft Excel *MasterStandards.xlsx* file documenting these CADD Standards which is also used by the productivity tools for both MicroStation and AutoCAD Civil 3D platforms, such as *QCInspector* (QC checking of design files during the Department’s plans preparation process). The *MasterStandards.xlsx* file is located in:

\FDOTXXX\APPS\ustnQCInspector\ folder for MicroStation *and*

\FDOTXXXX.C3D\APPS\QCInspector\ folder for Civil 3D.

**Note** 'XXX' or 'XXXX' represent the versioning of the Department’s CADD Software Suite (i.e. “SS4” for MicroStation or “2015” for Civil 3D).

➤ **The Department’s CADD Standard Design Libraries for MicroStation:**

Type	Design Library Name (DGNLIB)	Type	Design Library Name (DGNLIB)
Civil_Cells	FDOT_Approach.dgnlib	Features	FDOT_SUE_Uilities.dgnlib
Civil_Cells	FDOT_Circulatory.dgnlib	Features	FDOT_SurveyFeatures_RD.dgnlib
Civil_Cells	FDOT_CurbGutterMaker.dgnlib	Features	FDOT_SurveyFeatures_RW.dgnlib
Civil_Cells	FDOT_CurbTransitions.dgnlib	General	CivilCommands.dgnlib
Civil_Cells	FDOT_Driveways.dgnlib	General	FDOT_DesignGeometricsCriteria.dgnlib
Civil_Cells	FDOT_Intersections.dgnlib	General	FDOTtoolboxes.dgnlib
Civil_Cells	FDOT_Ponds.dgnlib	General	GeoTech.dgnlib
Civil_Cells	FDOT_RampTerminals.dgnlib	Levels	countymappinglevels.dgnlib
Civil_Cells	FDOT_SidewalkCurbRamps.dgnlib	Levels	fdot_common_levels.dgnlib
Civil_Cells	FDOT_Templates.dgnlib	Levels	fdot_v8_levels.dgnlib
Features	FDOT_CivilFeatures_RD.dgnlib	Levels	Photogrammetry_levels.dgnlib
Features	FDOT_CivilFeatures_RW.dgnlib	Levels	rwlevels.dgnlib
Features	FDOT_CivilFeatures_ST.dgnlib	Levels	strlevels.dgnlib
Features	FDOT_CivilFeatures_TC.dgnlib	Levels	survey_levels.dgnlib
Features	FDOT_CivilFeatures_TP.dgnlib	Levels	v7_levels.dgnlib
Features	FDOT_CivilFeatures_UT.dgnlib	Styles	FDOT_PrintStyles.dgnlib
Features	FDOT_ElementTemplates.dgnlib	Styles	FDOT_Styles.dgnlib
Features	FDOT_SUE_Drainage.dgnlib	Styles	rwstyles.dgnlib

➤ **The Department’s CADD Standard Design Templates for AutoCAD Civil 3D:**

Template	Description	Template	Description
fdotmaster.dwt	Master Template	StructuresTemplateDetail.dwt	Structural Details
keysht.dwt	Key Sheets	StructuresTemplatePlan.dwt	Structural Plans
planrd.dwt	Sheet Border for Details, Typical Sections & Summary Boxes	survey.dwt	Survey Development Model
rdxsrd.dwt	Roadway Cross Section	toporw.dwt	Existing Topography for Right of Way
rwtrd.dwt	Right of Way Detail for Roadway	utadrd.dwt	Utilities Adjustment
rweng10.dwt	Right of Way	utprrd.dwt	Utilities Proposed

### 3.7.1 Levels and Layers

The Department’s standard design libraries / templates define standard Level / Layer names. Designers must use these standard Levels / Layers in the Department’s plans production of all CADD standard design files. The following describes the Department’s basic level / layer naming convention:

The format of the Level / Layer Name convention is: **object\_sv** (maximum of 18 characters)

Where: (**object** = element type)\_(**s** = state)(**v** = view)

<u>(S)ate Designations</u>	<u>(V)iew Designations</u>
<b>p</b> (Proposed)	<b>p</b> (Plan)
<b>d</b> (Drafting element)	<b>r</b> (Profile)
<b>e</b> (Existing)	<b>x</b> (Cross Section)
	<b>m</b> (Model)

**Note** Level / layer names with no “\_sv” suffix on the name are assumed to be \_pp (Proposed state & Plan view). Example: With this one can determine the following about the example Level / Layer names below:

gas	- Proposed state & Plan view elements for “gas” related items
gas_ep	- Existing state & Plan view elements for “gas” related items
gas_px	- Proposed state & Cross Section view elements for “gas” related items

The Department’s CADD standard Levels / Layers are also classified as either *Critical* or *Non-Critical* for purposes of the QC processes to verify compliancy of design files. *Non-Critical* Levels / Layers are only checked in the QC process for compliancy with valid standard Level / Layer names only. *Critical* Levels that are relied upon and used by downstream applications (or other disciplines) are checked in the QC process for compliancy with both valid standard level names along with “ByLevel” / “ByLayer” settings for symbology (Color, Line Style, and Weight).

The CADD standard rules, documented in the *MasterStandards.xlsx* resource file and in *Appendix A*, contain a *Critical Level* column that defines each level with the following designations:

- **[blank]** Denotes Non-Critical Levels where ONLY valid Standard Level Name is checked in the QC process.
- **X** Denotes Critical Levels where valid Standard Level Name and ByLevel setting for Symbology (color, line style, and weight) are checked in the QC process.
- **3 digit string** Denotes Critical Level with partial checking in the QC process on whether to check (1=true) or not to check (0=false) specific symbology components: (Color, Line Style, Weight)

(1st digit = Color, 2nd digit = Line Style, 3rd digit = Weight)

Example: 100 – Denotes to check only color (common for structures files)  
 010 – Denotes to check only line style  
 101 – Denotes check both color & weight, but not line style

The Department’s standard Design Files are also classified as either *Critical* or *Non-Critical* for the purpose of verifying the compliance threshold. *Non-critical* Design Files must meet a minimum 80% compliance threshold for CADD Standard Levels / Layers. *Critical* Design Files must meet a minimum 95% compliance threshold for CADD Standard Levels / Layers. If critical files do not meet threshold requirements, a written variance from the Department’s Project Manager with supporting documentation must be included within the Project Journal.

**Note** The threshold percentage is calculated as the number of graphical elements in the design file on the prescribed level symbology divided by the total number of elements in that design file.

The Department provides Standard Rules which define the prescribed level symbology for each Standard design file. Exceptions are a deviation from those Standard Rules for any given project folder. For example, if a municipality required a special symbology for an element needed that was not covered in a Standard Rule, that element could be drawn with the special symbology and all occurrences of that symbology would be counted as only one exception. The Department provides a tool, *QCInspector*, for both Bentley and Autodesk platforms to examine and report CADD file compliance. This tool provides for up to 10 exceptions per design file before the compliance threshold begins to diminish.

### 3.7.2 Color

The Department uses a standard color table (*FDOTColor.tbl*) in MicroStation to visually recognize elements in files and for consistency in color printing. The standard color table is a modified version of the default MicroStation color table (*color.tbl*) which defines 256 colors for CADD elements. The Department’s standard color table customizes colors by remapping the RGB values for various MicroStation color index numbers, as defined below.

In MicroStation, the standard color table (*FDOTColor.tbl*) is preset in the FDOT Workspace variable MS\_DEFCTBL and is attached in the standard seed files. AutoCAD uses the RGB values shown in the color tables.

**Note** The discipline sections of Chapter 4 of this Manual define any discipline specific customize color tables. Structures discipline uses the default MicroStation Color Table (*color.tbl*).

MicroStation Color Index	color.tbl (AutoCAD Index) RGB Value	FDOTColor.tbl (AutoCAD Index) Color RGB Value
0	(7) 255,255,255	(7) 255,255,255
1	(5) 0,0,255	(5) 0,0,255
2	(3) 0,255,0	(3) 0,255,0
3	(1) 255,0,0	(1) 255,0,0
4	(2) 255,255,0	(2) 255,255,0
5	(6) 255, 0,255	(6) 255, 0,255
6	255,127,0	255,165,0
7	(4) 0,255,255	(4) 0,255,255
8	64,64,64	148,0,211
9	192,192,192	140,88,44
10	254,0,96	200,176,125
11	160,224,0	192,192,192
12	0,254,160	255,192,203
13	128,0,160	0,100,0
14	176,176,176	176,176,176
15	0,240,240	0,240,240
16	240,240,240	240,240,240
17	0,0,240	0,0,240
18	0,240,0	0,240,0
19	240,0,0	240,0,0
20	240,240,225	225,225,225
21	240,0,240	240,0,240
22	240,122,0	240,122,0
23	0,240,240	0,240,240
24	240,240,240	240,240,240
25	0,0,240	0,0,240
26	0,240,0	0,240,0

MicroStation Color Index	color.tbl (AutoCAD Index) RGB Value	FDOTColor.tbl (AutoCAD Index) RGB Value
27	240,0,0	240,0,0
28	240,240,0	240,240,0
29	240,0,240	240,0,240
30	240,122,0	240,122,0
31	0,255,255	0,255,255
32	225,225,225	225,225,225
33	0,0,225	0,0,225
34	225,225,0	225,225,0
35	225,0,0	225,0,0
36	225,225,0	225,225,0
37	225,0,225	225,0,225
38	225,117,0	225,117,0
39	0,225,225	0,225,225
46	225,117,0	225,117,0
55	0,210,210	0,210,210
68	195,195,0	195,195,0
71	0,195,195	0,195,195
84	180,180,0	180,180,0
86	180,102,0	180,102,0
99	165,0,0	165,0,0
100	165,165,0	165,165,0
142	135,87,0	135,87,0
150	120,82,0	120,82,0
152	120,120,120	120,120,120
154	0,120,0	0,120,0
157	120,0,120	120,0,120
255	(250) 0,0,0	(250) 0,0,0

**Note** Color 255 is used as the background color (usually black).



### 3.7.3 Line Weight

Line weight for MicroStation is defined by index value in the range of 0 to 31 that selects the stroke width (or thickness) of the line used to draw and print a graphic element. Each element has its own line weight. The standard line thickness (width) of a printed element is usually in inches on the paper defined by a print driver file.

Printed output from the design file must be of a quality legible on 2<sup>nd</sup> generation copies. Line weights / thicknesses in the following table are default settings (also set in Department delivered print drivers). These may need to be user-adjusted depending on hardware to produce the required quality of printed documents.

<b>MicroStation / AutoCAD Line Weight Mapping</b>				<b>Available AutoCAD Line Weights</b>	
<i>MS Weight</i>	<i>MS Plot(inches)</i>	<i>AutoCAD (inches)</i>	<i>AutoCAD (mm)</i>	<i>inches</i>	<i>mm</i>
0	0.003	0.004	0.09	0	0.000
1	0.006	0.006	0.15	0.002	0.050
2	0.009	0.008	0.20	0.004	0.090
3	0.012	0.012	0.30	0.005	0.130
4	0.015	0.014	0.35	0.006	0.150
5	0.018	0.016	0.40	0.007	0.180
6	0.021	0.021	0.53	0.008	0.200
7	0.024	0.024	0.60	0.01	0.250
8	0.027	0.028	0.70	0.012	0.300
9	0.030	0.031	0.80	0.014	0.350
10	0.033	0.035	0.90	0.016	0.400
11	0.036	0.035	0.90	0.02	0.500
12	0.039	0.039	1.00	0.021	0.530
13	0.042	0.042	1.06	0.024	0.600
14	0.045	0.047	1.20	0.028	0.700
15	0.048	0.047	1.20	0.031	0.800
16	0.051	0.055	1.40	0.035	0.900
17	0.054	0.055	1.40	0.039	1.000
18	0.057	0.055	1.40	0.042	1.060
19	0.106	0.083	2.11	0.047	1.200
20	0.105	0.083	2.11	0.055	1.400
21	0.110	0.083	2.11	0.062	1.580
22	0.115	0.083	2.11	0.079	2.000
23	0.120	0.083	2.11	0.083	2.110
24	0.125	0.083	2.11		
25	0.130	0.083	2.11		
26	0.135	0.083	2.11		
27	0.140	0.083	2.11		
28	0.145	0.083	2.11		
29	0.150	0.083	2.11		
30	0.155	0.083	2.11		

### 3.7.4 Line Styles / Linetypes

MicroStation Line Style (or AutoCAD Linetype) is part of the symbology of graphic elements, which defines a line's appearance. Each element has its own Line Style / Linetype which can be set to a standard line Style / Linetype or to a Custom Line Style / Linetype.

Standard MicroStation Line Styles are based on output device coordinates, therefore are not truly "what you see is what you get". Custom Line Styles should be used instead of MicroStation line patterning.

————— 0	style(0) = continuous
----- 1	style(1) = (0.02, 0.04), for ACAD - DGN1
- - - - - 2	style(2) = (0.08, 0.04), for ACAD - DGN2
- - - - - 3	style(3) = (0.15, 0.05), for ACAD - DGN3
- . - . - . 4	style(4) = (0.200, 0.053, 0.03, 0.053), for ACAD – DGN4
- - - - - 5	style(5) = (0.056, 0.056), for ACAD - DGN5
- . - . - . 6	style(6) = (0.32, 0.056, 0.048, 0.056, 0.048,0.056), for ACAD – DGN6
- - - - - 7	style(7) = (0.59, 0.053, 0.03, 0.053), for ACAD – DGN7

➤ **To set custom line style scale, select the MicroStation menu option:**

Element > Line Styles > Custom:

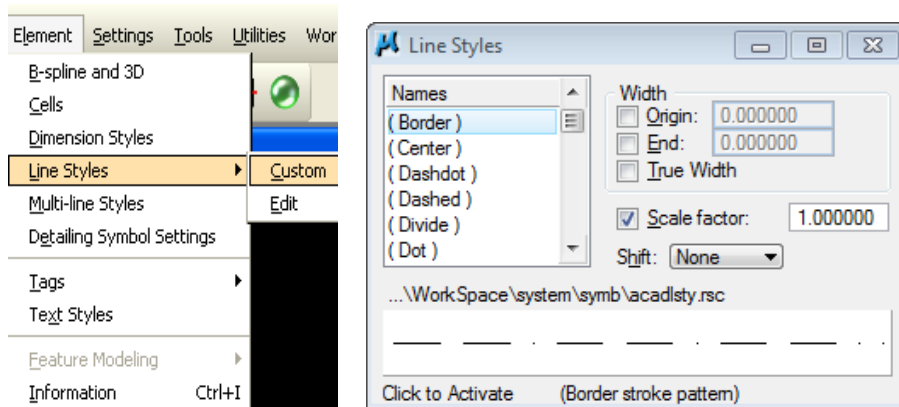

In most instances the MicroStation Custom Line Style name will match the AutoCAD Linetypes, which are defined for AutoCAD in the file *FDOT.lin* located in the *\FDOTXXX.C3D\Support\linetype\* folder.

MicroStation Line Style	AutoCAD Linetype
0	Continuous
1	DGN1
2	DGN2
3	DGN3
4	DGN4
5	DGN5
6	DGN6
7	DGN7

The Department includes Standard Custom Line Style / Linetype resource files in both the CADD Software Suite for Bentley and the FDOT State Kit for Autodesk.

FDOT Custom Line Style Resource Files for MicroStation
FDOT_3D.rsc
FDOT_MOT.rsc
FDOT_Rdwy.rsc
FDOT_Road.rsc
FDOT_ROW.rsc
FDOT_Striping.rsc
FDOT_Uilities.rsc

FDOT Custom Linetype Resource Files for AutoCAD
FDOT.LIN

The Department’s Standard Custom Line Style / Linetypes can be complex and contain arrangements of line segments and / or symbols. Users must not modify the Department’s Standard Custom Line Style / Linetypes resource files.

If Non-Standard Custom Line Style / Linetypes are required for a design, other resource files are allowed to be user-defined, but they must be delivered in the \symb\ sub-folder of the FDOT Project folder structure, or the Non-Standard Custom Line Style / Linetype definitions must be embedded in the design file.

**Note** The user must not create conflicting custom line styles / linetypes with the same name as a Department Standard Line Style / Linetype. User created resource files must be unique in both name and appearance.

**3.7.4.1 Custom Line Styles**











Some MicroStation Line Styles (\*) containing leaders and some complex markings and striping needed to be place to scale are not created as AutoCAD Linetypes for the FDOT State Kit for Civil 3D. Tools such as *Entity Manager*, *Place Block Group* and the *Pavement Marking* tool can create these types of additional striping for AutoCAD.

**Note** Unless otherwise stated, all styles listed in the following table are used for new or proposed elements.

Name	Description	Sample Image
MOT-Attenuator	Attenuator	
MOT-ChannelDevPed	Channelizing Device Pedestrian	
PM-Delineator-300Gap*	Delineator Point 300' Gap	
PM-Delineator-40Gap*	Delineator Point 40' Gap	
PM-RumbleSkip	Rumble Strip Skip	
PM-RumbleSolid	Rumble Strip Solid	
PM-Stripe-10' Crosswalk	Crosswalk 10ft Component	
PM-Stripe-10'_20'Skip	10'/30' Contrast Skip Striping	
PM-strupe-2'_2'Skip	2ft / 2ft / 2ft Contrast Skip	
PM-Stripe-6' Crosswalk	Crosswalk 6ft Component	
PM-Stripe-RumbleStripeLeft	Rumble Striping Left	
PM-Stripe-RumbleStripeRight	Rumble Striping Right	
PM-Stripe-VibratoryLeft	Vibratory Line Left	

Name	Description	Sample Image
PM-Stripe-VibratoryRight	Vibratory Line Right	
PM-Stripe-YieldLarge	Yield Large	
PM-Stripe-YieldSmall	Yield Triangle Component	
RD-CableBarrier	Cable Barrier	
RD-Fence	Fence Line	
RD-Guardrail-Double	Guardrail Double	
RD-Guardrail-Left	Guardrail Left	
RD-Guardrail-Right	Guardrail Right	
RD-LaneLine-Existing	Lane Line Existing	
RD-PavedShldr 10'	Paved Shoulder Pattern 10'	
RD-PavedShldr 12'	Paved Shoulder Pattern 12'	
RD-PavedShldr 15'	Paved Shoulder Pattern 15'	
RD-PavedShldr 2'	Paved Shoulder Pattern 2'	
RD-PavedShldr 4'	Paved Shoulder Pattern 4'	
RD-PavedShldr 5'	Paved Shoulder Pattern 5'	
RD-PavedShldr 6'	Paved Shoulder Pattern 6'	
RD-PavedShldr 7'	Paved Shoulder Pattern 7'	
RD-PavedShldr 8'	Paved Shoulder Pattern 8'	
RD-Railroad-Existing	Railroad Existing	
RD-Railroad-Proposed	Railroad Proposed	
RD-TreeLine	Tree Line	
RD-Wetland-Existing	Wetland Existing	
RD-Wetland-Proposed	Wetland Proposed	
RW-ArrowTie*	Dimension Existing	
RW-CityLimit-Type1	City Limit	
RW-CityLimit-Type2	City Limit	
RW-CountyLine	County Line	
RW-Dimension-Type1*	Dimension Type 1	
RW-Dimension-Type2*	Dimension Type 2	
RW-Easement	Easement Stroke	
RW-EasementCL-Existing	Existing Easement Centerline	
RW-Existing	Existing Right of Way	
RW-GrantLine	Government: Grant Line	

Name	Description	Sample Image
RW-Leader*	Arrow	
RW-LeaderLeft*	Begin End Leader Left	
RW-LeaderRight*	Begin End Leader Right	
RW-License	License (Agreement)	
RW-LimitedAccess-Existing	Existing Limited Access	
RW-LimitedAccess-Proposed	Proposed Limited Access	
RW-LimitsOfConst	Limits of Construction	
RW-Nat/StPark/Forest-Type1	National or State Forest Park	
RW-Nat/StPark/Forest-Type2	National or State Forest Park Hash	
RW-NonVehicularAccess	Non-Vehicular Access Line	
RW-PerpetualEasement	Perpetual Easement	
RW-PropertyLine	Property Line	
RW-Proposed	Proposed Right of Way	
RW-QuarterSection	Quarter Section	
RW-RailroadBL	RailRoad	
RW-SectionLine	Section Line	
RW-StateLine	Government: State Line	
RW-Subdiv-Double*	Subdivision Boundary Arrows Double	
RW-Subdiv-DoubleLeft*	Subdivision Boundary Arrows Two Left	
RW-Subdiv-DoubleLeftOnly*	Subdivision Boundary Arrows Two Left Only	
RW-Subdiv-DoubleRight*	Subdivision Boundary Arrows Two Right	
RW-Subdiv-DoubleRightOnly*	Subdivision Boundary Arrows Two Right Only	
RW-Subdiv-Single*	Subdivision Boundary Arrows	
RW-Subdiv-SingleLeft*	Subdivision Boundary Arrows Single Left	
RW-Subdiv-SingleRight*	Subdivision Boundary Arrows Single Right	
RW-TemporaryEasement	Easements Temporary	
RW-TIITFMurphyResLine	Safe Upland TIITF - Murphy Reservation	
RW-TownshipRange	Township Range	
RW-WaterMapBoundary	Major Water Mapping Boundary	
SG-Cable	Signal Cable	
SG-Conduit	Signal Conduit	
SG-Conduit-Existing	ConduitLT Existing	
SG-ConduitAG-Proposed	Conduit – Above Ground	

Name	Description	Sample Image
SG-ConduitBM-Proposed	Conduit – Bridge Mount	
SG-ConduitDB-Proposed	Conduit – Directional Bore	
SG-ConduitJB-Proposed	Conduit – Jack & Bore	
SG-ConduitOT-Proposed	Conduit – Open Trench	
SG-InterconCable-Existing	Interconnect Cable Existing	
SG-InterconCable-Proposed	Interconnect Cable Proposed	
SWP-HayBales	Hay Bales	
SWP-RockBags	Rock Bag Symbols	
SWP-SiltFence	Silt Fence	
SWP-TurbidityBarrier-Type1	Turbidity Barrier Type 1	
SWP-TurbidityBarrier-Type2	Turbidity Barrier Type 2	
UT-BuriedCable-Existing(B)	Buried Cable TV Existing Type B	<i>BTV(B) - - - - - BTV(B) - - - - -</i>
UT-BuriedCable-Existing(C)	Buried Cable TV Existing Type C	<i>BTV(C) - - - - - BTV(C) - - - - -</i>
UT-BuriedCable-Existing(D)	Buried Cable TV Existing Type D	<i>BTV(D) - - - - - BTV(D) - - - - -</i>
UT-BuriedCable-Proposed	Buried Cable TV Proposed	<i>BTV BTV BTV BTV BTV BTV BTV</i>
UT-BuriedElec-Existing(B)	Buried Electric Existing Type B	<i>BE(B) - - - - - BE(B) - - - - -</i>
UT-BuriedElec-Existing(C)	Buried Electric Existing Type C	<i>BE(C) - - - - - BE(C) - - - - -</i>
UT-BuriedElec-Existing(D)	Buried Electric Existing Type D	<i>BE(D) - - - - - BE(D) - - - - -</i>
UT-BuriedElec-Proposed	Buried Electric Proposed	<i>BE BE BE BE BE BE BE BE BE BE</i>
UT-BuriedFOC(B)-Existing	Buried Fiber Optic Cable Existing Type B	<i><b>BFOC(B) - - - - - BFOC(B) - -</b></i>
UT-BuriedFOC(C)-Existing	Buried Fiber Optic Cable Existing Type C	<i><b>BFOC(C) - - - - - BFOC(C) - -</b></i>
UT-BuriedFOC(D)-Existing	Buried Fiber Optic Cable Existing Type D	<i><b>BFOC(D) - - - - - BFOC(D) - -</b></i>
UT-BuriedFOC-Proposed	Buried Fiber Optic Cable Proposed	<i><b>BFOC BFOC BFOC BFOC BFOC BFOC</b></i>
UT-BuriedFOE(B)-Existing	Buried Fiber Optic Electric Existing Type B	<i><b>BFOE(B) - - - - - BFOE(B) - -</b></i>
UT-BuriedFOE(C)-Existing	Buried Fiber Optic Electric Existing Type C	<i><b>BFOE(C) - - - - - BFOE(C) - -</b></i>
UT-BuriedFOE(D)-Existing	Buried Fiber Optic Electric Existing Type D	<i><b>BFOE(D) - - - - - BFOE(D) - -</b></i>
UT-BuriedFOE-Proposed	Buried Fiber Optic Electric Proposed	<i><b>BFOE BFOE BFOE BFOE BFOE BFOE</b></i>
UT-BuriedFOT(B)-Existing	Buried Fiber Optic Telephone Existing Type B	<i><b>BFOT(B) - - - - - BFOT(B) - -</b></i>
UT-BuriedFOT(C)-Existing	Buried Fiber Optic Telephone Existing Type C	<i><b>BFOT(C) - - - - - BFOT(C) - -</b></i>
UT-BuriedFOT(D)-Existing	Buried Fiber Optic Telephone Existing Type D	<i><b>BFOT(D) - - - - - BFOT(D) - -</b></i>
UT-BuriedFOT-Proposed	Buried Fiber Optic Telephone-Proposed	<i><b>BFOT BFOT BFOT BFOT BFOT BFOT</b></i>
UT-BuriedTel-Existing(B)	Buried Telephone Existing Type B	<i><b>BT(B) - - - - - BT(B) - -</b></i>
UT-BuriedTel-Existing(C)	Buried Telephone Existing Type C	<i><b>BT(C) - - - - - BT(C) - -</b></i>

Name	Description	Sample Image
UT-BuriedTel-Existing(D)	Buried Telephone Existing Type D	<b>BT(D)</b> - - - - - <b>BT(D)</b> - -
UT-BuriedTel-Proposed	Buried Telephone Proposed	<b>BT BT BT BT BT BT BT BT BT</b>
UT-Casing-Existing(B)	Encasement Existing Type B	CAS(B) - - - - - CAS(B) - - - -
UT-Casing-Existing(C)	Encasement Existing Type C	CAS(C) - - - - - CAS(C) - - - -
UT-Casing-Existing(D)	Encasement Existing Type D	CAS(D) - - - - - CAS(D) - - - -
UT-Casing-Proposed	Encasement Proposed	CAS CAS CAS CAS CAS CAS CAS
UT-Duct-Proposed	Duct Proposed	DT DT DT DT DT DT DT DT DT DT
UT-Gas-Existing(B)	Gas Existing Type B	G(B) - - - - - G(B) - - - - -
UT-Gas-Existing(C)	Gas Existing Type C	G(C) - - - - - G(C) - - - - -
UT-Gas-Existing(D)	Gas Existing Type D	G(D) - - - - - G(D) - - - - -
UT-Gas-Proposed	Gas Proposed	G G G G G G G G G G G G G G G G
UT-NonPotableWater-Existing(B)	Non-Potable Water Existing Type B	NPW(B) - - - - - NPW(B) - - - -
UT-NonPotableWater-Existing(C)	Non-Potable Water Existing Type C	NPW(C) - - - - - NPW(C) - - - -
UT-NonPotableWater-Existing(D)	Non-Potable Water Existing Type D	NPW(D) - - - - - NPW(D) - - - -
UT-NonPotableWater-Proposed	Non-Potable Water Proposed	NPW NPW NPW NPW NPW NPW NPW
UT-OverheadCable-Existing	Overhead Cable TV Existing	OTV - - - - - OTV - - - - -
UT-OverheadCable-Proposed	Overhead Cable TV Proposed	OTV OTV OTV OTV OTV OTV OTV
UT-OverheadElec-Existing	Overhead Electric Existing	OE - - - - - OE - - - - -
UT-OverheadElec-Proposed	Overhead Electric Proposed	OE OE OE OE OE OE OE OE OE OE
UT-OverheadFOC-Existing	Overhead Fiber Optic Cable Existing	<b>OFOC</b> - - - - - <b>OFOC</b> - -
UT-OverheadFOC-Proposed	Overhead Fiber Optic Cable Proposed	<b>OFOC OFOC OFOC OFOC OFOC</b>
UT-OverheadFOE-Existing	Overhead Fiber Optic Electric Existing	<b>OFOE</b> - - - - - <b>OFOE</b> - - -
UT-OverheadFOE-Proposed	Overhead Fiber Optic Electric Proposed	<b>OFOE OFOE OFOE OFOE OFOE</b>
UT-OverheadFOT-Existing	Overhead Fiber Optic Telephone Existing	<b>OFOT</b> - - - - - <b>OFOT</b> - -
UT-OverheadFOT-Proposed	Overhead Fiber Optic Telephone Proposed	<b>OFOT OFOT OFOT OFOT OFOT</b>
UT-OverheadTel-Existing	Overhead Telephone Existing	OT - - - - - OT - - - - -
UT-OverheadTel-Proposed	Overhead Telephone Proposed	OT OT OT OT OT OT OT OT OT OT
UT-Petroleum-Existing(B)	Petroleum Existing Type B	PET(B) - - - - - PET(B) - - - -
UT-Petroleum-Existing(C)	Petroleum Existing Type C	PET(C) - - - - - PET(C) - - - -
UT-Petroleum-Existing(D)	Petroleum Existing Type D	PET(D) - - - - - PET(D) - - - -
UT-Petroleum-Proposed	Petroleum Proposed	PET PET PET PET PET PET PET
UT-Sanitary-Existing(B)	Sanitary Existing Type B	S(B) - - - - - S(B) - - - - -
UT-Sanitary-Existing(C)	Sanitary Existing Type C	S(C) - - - - - S(C) - - - - -

Name	Description	Sample Image
UT-Sanitary-Existing(D)	Sanitary Existing Type D	<i>S(D)</i> - - - - - <i>S(D)</i> - - - - -
UT-Sanitary-Proposed	Sanitary Proposed	<i>S S</i>
UT-Steam-Existing(B)	Steam Existing Type B	<i>STM(B)</i> - - - - - <i>STM(B)</i> - - - - -
UT-Steam-Existing(C)	Steam Existing Type C	<i>STM(C)</i> - - - - - <i>STM(C)</i> - - - - -
UT-Steam-Existing(D)	Steam Existing Type D	<i>STM(D)</i> - - - - - <i>STM(D)</i> - - - - -
UT-Steam-Proposed	Steam Proposed	<i>STM STM STM STM STM STM STM</i>
UT-Water-Existing(B)	Water Existing Type B	<i>W(B)</i> - - - - - <i>W(B)</i> - - - - -
UT-Water-Existing(C)	Water Existing Type C	<i>W(C)</i> - - - - - <i>W(C)</i> - - - - -
UT-Water-Existing(D)	Water Existing Type D	<i>W(D)</i> - - - - - <i>W(D)</i> - - - - -
UT-Water-Proposed	Water Proposed	<i>W W W W W W W W W W W W W W W W W W</i>

### 3.8 CELL LIBRARIES / BLOCK DRAWINGS

Cells / Blocks are frequently used as repeated components of drawings made up of complex symbols, notations, details, or parts of drawings that can be inserted into one or many other drawings. Cells are defined and stored in MicroStation design files called a Cell Libraries with a .cel file extension and in AutoCAD are called Blocks Drawings.

Cells / Blocks have been grouped by disciplinary usage into the Department’s Standard Cell Libraries delivered with the CADD Software Suite for MicroStation located under the FDOTXXX\RESOURCES\Cell\ subfolder and Block Drawings delivered in the FDOT State Kit for AutoCAD located under the FDOTXXX.C3D\Data\Blocks\ subfolder.



The Department's Standard Cell Libraries / Block Drawings are listed in the following table:

**Note** AutoCAD Block Drawings can be accessed via AutoCAD's Design Center to access individual blocks.

MicroStation CELL LIBRARIES	AutoCAD BLOCK DRAWINGS	DESCRIPTION
alphabet.cel	(Not Applicable)	Alphabet & Numbers
arrows.cel	arrows.dwg	Distance & GuidSIGN Arrows
(Not Applicable)	BoreHOLE.dwg	Bore Holes
Drain_Bottom3D.cel	(Not Applicable)	Drainage Bottom (3 Dimensional used for SUDA)
Drain_Curbs3D.cel	(Not Applicable)	Drainage Curbs (3 Dimensional used for SUDA)
Drain_Grate3D.cel	(Not Applicable)	Drainage Grate (3 Dimensional used for SUDA)
Drain_Junction3D.cel	(Not Applicable)	Drainage Junction (3 Dimensional used for SUDA)
Drain_Outlet3D.cel	(Not Applicable)	Drainage Outlet (3 Dimensional used for SUDA)
DrainXS.cel	DrainXS.dwg	Drainage Structure Cross Sections
(Not Applicable)	Driveway.dwg	Driveways
drplan.cel	drplan.dwg	Drainage Proposed
drplan_ex.cel	drplan_ex.dwg	Drainage Existing
ftpsigns.cel	ftpsigns.dwg	Florida Traffic Plans Signs
geotech.cel	geotech.dwg	Geotechnical
its.cel	its.dwg	Intelligent Transportation Systems Signs
Landscape.cel	landscape.dwg	Landscape
Lighting.cel	lighting.dwg	Lighting
(Not Applicable)	Master Table Drawing.dwg	Master of All Summary Tables
Mutcd.cel	mutcd.dwg	Manual on Uniform Traffic Control Devices
PavementMarkings.cel	pavementmarkings.dwg	Pavement Markings
Photogrammetry.cel	Photo.dwg	Photogrammetry
Roadway.cel	Roadway.dwg	Roadway
row.cel	ROW.dwg	Right of Way
rweng.cel	rweng.dwg	Survey Symbols for Right of Way
Seals.cel	Seals.dwg	Professional Seals for Digital Signatories
(Not Applicable)	Sheet Border.dwg	Sheet Borders
(Not Applicable)	SheetPOR-Consultant.dwg	Professional of Record for Consultants
Signalization.cel	signalization.dwg	Signalization
SignalPoles.cel	signalpoles.dwg	Signal Poles
syeng.cel	syeng.dwg	Survey Symbols for Roadway
TollPlaza.cel	TollPlaza.dwg	Toll Plaza Signs
tplabels.cel	tplabels.dwg	Traffic Plans Labels
TrafficControlPlans.cel	TrafficControlPlans.dwg	Traffic Control Plans
TrafficControlTypicals.cel	TrafficControlTypicals.dwg	Traffic Control Typical
TTF_v8semi-standards.cel	Semi-Standards.dwg	Structures Semi-standards
TTF_v8structures.cel	Structures.dwg	Structures
TypicalSection.cel	TypicalSections.dwg	Typical Sections
utilities.cel	utilities.dwg	Utilities
Utilities3D.cel	(Not Applicable)	Utilities (3 Dimensional)
v8structurespatterns.cel	(Not Applicable)	Patterns for Structures
XMSuperSection.cel	(Not Applicable)	Structures for Super sections
xsections.cel	(Not Applicable)	Cross Sections

## 3.9 TEXT

The Department delivers a set of True Type Font (TTF) files to ensure text uniformity between applications supporting TTF fonts and legibility of CADD drawings. The Department’s CADD Software Suite delivers a set of proportional and uniformed spaced True Type Font files using vertical and slanted characters, the detail of which is reflected in the table below. These font files have additional characters added into the gaps of the Unicode definition, so engineering symbols like:  $\mathcal{L}$ ,  $\overline{\mathcal{L}}$ ,  $\mathcal{B}$ ,  $\Delta$  and fraction combinations are supported in the FDOT fonts directly. The MicroStation based *zdotfont.rsc* and *structuresfont.rsc* resource files are also delivered with the CADD Software to maintain legacy compatibility for older CADD files predating the use of True Type fonts.

Although not recommended, MicroStation can utilize fonts contained within MicroStation RSC, AutoCAD SHX, and True Type Font files. MicroStation will read multiple font resource files according to the paths set by the MS\_FONTSPATH configuration variable in the selected workspace, and True Types Fonts registered with the Windows operating system. Within a MicroStation design file, font resources are compiled into a list of fonts from all the resource files that are found. The *MstnFontConfig.xml* file located by the MS\_FONTCONFIGFILE variable determines if duplicate font names are displayed in font selection and lists how to resolve duplicate font names. Likewise AutoCAD can utilize multiple font sources. It is strongly recommended to use the FDOT True Type fonts exclusively.

### 3.9.1 True Type Fonts (TTF)

The Department’s TTF files contain special characters used by designers that are not normally found in standard publishing fonts. (See the Unicode mapping standard: <http://www.unicode.org/charts/>)

**Note** If the FDOT TTF files are registered with the Windows operating system, the fonts may be used in any standard Windows program like Word, Excel, or any other applications supporting TTF.

Font	Description
FDOT	Standard slanted proportional spaced font used for most annotations
FDOT Bold	Bold version of the FDOT font
FDOT Heavy	Heavier Bold version of the FDOT font
FDOT Imprint	Chiseled font ( <i>Used mainly within the FDOT sheet border</i> )
FDOT Imprint Bold	Bold version of FDOTImprint font ( <i>Used mainly within the FDOT sheet border</i> )
FDOT Mono	Standard mono-spaced font ( <i>Used mainly in tables to keep characters aligned vertically</i> )
FDOT Mono Bold	Bold version of FDOTMono font
FDOT Mono Heavy	Heavier Bold version of FDOTMono font
FDOT Vert	Non-slanted proportional spaced version of FDOT font ( <i>Used mainly by Right Of Way discipline</i> )
FDOT Vert Bold	Bold version of FDOTVert font ( <i>Used mainly by ROW</i> )
FDOT Vert Heavy	Heavier Bold version of FDOTVert font ( <i>Used mainly by ROW</i> )
FDOT Vert Mono	Mono-spaced version for FDOTVert font ( <i>Used mainly in tables used mainly by ROW</i> )
FDOT Vert Mono Bold	Bold version of FDOTVertMono font ( <i>Used mainly by ROW</i> )
FDOT Vert Mono Heavy	Heavier Bold version of FDOTVertMono font ( <i>Used mainly by ROW</i> )

### 3.9.2 Text Size and Spacing

The Department employs standard text sizes to ensure uniformity and legibility on CADD drawings and for printed output. The appropriate text size is dependent on the plot scale selected. Since the most important issue with text is legibility, the font, weight and text size may vary when necessary. Text line spacing should be, on average, three-fourths of the text height.

The Department’s CADD Software Suite provides several Text Levels and Text Styles for designers to choose as a starting point to create text to fit their needs. Text Levels can be identified by the Level / layer naming convention beginning with the string “Text” (i.e. TextBLStation, TextLable, TextNotes).

The following table should be used as a *guideline* for standard text size definitions for plans at given scales.

➤ **Text for B-Size Plans (11" x 17" paper)**

Scale	1"=1'	1"=20'	1"=40'	1"=50'	1"=100'	1"=200'	1"=400'	1"=500'
Minimum	0.06	1.2	2.4	3	6	12	24	30
Desired	0.07	1.4	2.8	3.5	7	14	28	35
Maximum	0.125	2	4	5	10	20	40	50

➤ **Text for D-Size Maps (24" x 36" paper)**

Scale	1"=1'	1"=20'	1"=40'	1"=50'	1"=100'	1"=200'	1"=400'	1"=500'
Minimum	0.08	1.6	3.2	4	8	16	32	40
Desired	0.10	2	4	5	10	20	40	50

## 3.10 MICROSTATION PRINT RESOURCE FILES

The Department’s CADD Software Suite supplies several MicroStation print configuration example files to generate prints to scale using the sheet cells (also provided with the CADD Software) on those specific printers. All print configuration files supplied have raster printing enabled. These print configuration files are examples due to various site-specific configurations and the types of printers that might be encountered.

The table below lists the print configuration file names and the type of printer on which it was developed and tested. Each printer has its own printable area on the paper for which it can print. For this reason, if a specific printer is not listed below, the print configuration file may require modification by the user to be used for another printer.

PRINT RESOURCE FILES	PRINTER	DESCRIPTION
36x24.pro	N / A	Controls postscript image/print output
Color.plt		Color 11x17 (Raster Capable) Uses FDOT.TBL pen table and PSCRIPT.PRO prolog file.
Color_FDOTPDF.pltcfg	N/A	Creates a color PDF file. (Raster Capable) Uses FDOT.TBL pen table.
Color_Keysheet.pltcfg	ANY	To be used when printing key sheets containing maps with filled shapes.
FDOT.tbl	N/A	Pen table that also enters username, date time, and sheet border path.

PRINT RESOURCE FILES	PRINTER	DESCRIPTION
FDOT_GrayExisting.tbl	N/A	Pen table that enters username, date time, sheet border path, and applies gray scale to files named like: TOPO*, UTEX*, and DREX*
FDOTbatchplt.spc	N/A	Batch print specification file customized for the Department's print configuration files. (Only used with old Batch Print dialog). This print configuration file is being replaced with Print Styles in MicroStation V8i)
FDOTPDF.plt	N/A	Creates a .PDF file. (Raster Capable) Uses FDOT.TBL pen table.
FDOTprinter.plt	Windows Printer	Copy of Bentley's PRINTER.PLT with weights and styles set to CADD standards. Uses FDOT.TBL pen table.
HP1055.plt	HP 1055 CM	Monochrome 36x24 (Raster Capable) Uses 36x24.PRO prolog file.
HP1055C.plt	HP 1055 CM	Color 36x24 (Raster Capable) Uses 36x24.PRO prolog file.
HP5000.plt	HP 5000 GN	Monochrome 11x17 (Raster Capable) Uses FDOT.TBL pen table and HPTTABL1.PRO prolog file.
HP5000Legal.plt	HP 5000 GN	Monochrome 8.5x14 (Raster Capable) Uses FDOT.TBL pen table and HPTLEGAL.PRO prolog file.
HP5000Letter.plt	HP 5000 GN	Monochrome 8.5x11 (Raster Capable) Uses FDOT.TBL pen table and HPTLETTER.PRO prolog file.
hpglrtl.pltcfg	Large Format	Intended for use when printing large format monochrome sheets. (Raster Capable)
hpglrtl_c.pltcfg	Large Format	Intended for use when printing large format color sheets. (Raster Capable)

PostScript.plt	N/A	Creates postscript image file. (Raster Capable) Uses FDOT.TBL pen table and HPTTABL1.PRO prolog file.
Postscript36x24.plt	N/A	Creates postscript image file. (Raster Capable) Uses FDOT.TBL pen table and 36x24.PRO prolog file.
pscript.pro	N/A	Controls postscript image / print output
XeroxN40.plt	XEROX Docuprint N4025	Monochrome 11x17 (Raster Capable) Uses FDOT.TBL pen table and HPTTABL1.PRO prolog file.

### 3.11 AutoCAD/Civil 3D PRINT RESOURCE FILES

The Department's CADD Software Suite supplies several AutoCAD print configuration files to generate prints to the Departments print standards.

PRINT RESOURCE FILES	DESCRIPTION
FDOT.stb	Controls the color mapping of display objects to print objects.
FDOTPDF.pc3	Predefined pdf plot settings such as paper size/orientation, margins, plotter name.
FDOTPDF.pmp	Used to define custom paper sizes.

# Chapter 4

## CADD PRODUCTION PROCEDURES

### 4.1 PURPOSE

This chapter establishes the minimum requirements for the production of Florida Department of Transportation (Department) Computer Aided Design and Drafting (CADD) projects in accordance with the Department's plans preparation procedures and practices.

### 4.2 SCOPE

These procedures are applicable to the CADD applications utilized by and for the Department in the production process. They are intended to complement and support the policies, procedures and standards of the Department in accordance with *Procedure No. 025-020-002, Standard Operating System*.

### 4.3 ACCOUNTABILITY

These procedures do not exempt the professional from performing responsible engineering, surveying and mapping or architecture. The policies and procedures of the Department and appropriate professional practice take precedence when providing professional services for the Department. The professional must have the final responsibility for the accuracy of all input and output of CADD applications.

### 4.4 DEFINITIONS

**Bid Set:** A sub-set of files consisting of data derived from the overall Project Data Set containing only those files needed for the advertisement and letting of a project. The files needed for the Bid Set remain in their source folder structure derived from the Project Data set. For Digital Delivery projects, the data in the Bid Set is usually compiled manually and put in a ZIP file with a naming convention defined later in this chapter.

**CADD Production:** The development of projects utilizing CADD applications, software and discipline-based processes.

**Calculations Folder:** Excel files, PDF files and any associated quantity backup data for the plan summary boxes.

**DQE: Design Quantities and Estimates System.** The Department's program for estimating construction cost for projects.

**Digital Delivery:** A method to deliver project data which relies upon creating a compressed archive (ZIP file) of project data, Portable Document Format (PDF) files of Plans and Specifications documents, which are signed and sealed with a Digital Signature.

**Engineering Data:** Those electronic files that represent the critical geometric and quantitative controls or other data supporting the graphical representation (design) of a project.

**File Checker:** An application to assist with the verification of Quality Control (QC) compliance to Delivery standards, such as folder structure, file naming, etcetera.

**Journal:** Electronic file(s) that document development, correspondence, decisions made, methodology used, exceptions to standards, or other descriptive information about the project. The Electronic Journal includes details that must give future users insight about the project data.

**Letting:** The process of advertising, selection, and award of a contract for the construction of a project.

**Plans Change:** (*Plans Preparation Manual* (PPM) Volume 1, Chapter 20 definition) Modification to a set of plans, after Program Management has changed the Control Group, but before the plans are sent to the Department's Central Office.

**Project:** Projects are identified by the Department through the Financial Project Identification Number (FPID) which becomes the name of the project's root folder. Note that multiple deliveries can occur for a single project, each representing the status of the project at the time of delivery.

**Project Component:** All electronic files that represent and support a delivery by a discipline as part of a project.

**Project Discipline Folder:** The data structure and organization of electronic files on the storage media, as a sub-folder of the project's root folder.

**Project Data Set:** All of the files used or produced during the development of the project and placed in the Project Folder structure.

**Project Folder:** The parent folder of a project containing all project component Folders and data (see Project Root Folder).

**Project Manager:** The person responsible for ensuring that the scope of work is accomplished for a project and the receipt, acknowledgment, validation and acceptance of the project data.

**Project Root Folder:** The file system folder that contains all of the projects' files and folders. The project root folder should not contain files that do not pertain to the project, nor should files that are part of the project reside outside of the project root folder, or one of its sub-folders.

**Reference File:** A design file or other file type that is attached to and viewed simultaneously with the active design file.

**Resolution:** The number of addressable points across a given area. For example, printer resolution is measured in lines or dots per inch, while screen resolution is usually given indicating the number of pixels across the width and height of the largest image that can be displayed. MicroStation design files have a user-definable resolution, called Units of Resolution (UORs).

**Root Certificate:** Cryptographic information installed on a computer that identifies the Certificate Authority and allows the identity of the Signatory to be validated against the identity records held by the Certificate Authority. This process usually requires a connection to the Internet.

**Seed File:** A predefined settings file used to create a new design files or cell libraries.

**Seed Project:** A predefined folder structure that contains all folders listed further in this chapter, as well as other project configuration files. The "seed" is the beginning structure of a project which gets populated with data as the project development occurs.

**Sheet Navigator:** An application which runs within MicroStation, allowing users to browse and open MicroStation files containing sheets for verification or editing. Its purpose is to 'tag' sheets with data that supports later processes for both Indexing and Printing. It is a foundation utility for delivery processes and should be run against every MicroStation design file containing sheets.

**Sheet Set Organizer (SSO):** An application which runs in conjunction with AutoCAD's Sheet Set Manager. Its purpose is to combine and organize .DST files created by Sheet Set Manager. It updates fields in DWG files with data that supports later indexing and printing. It is a foundation utility for subsequent delivery processes using AutoCAD Civil 3D, ensuring sheet data can be extracted properly.

**Strung Project:** Two or more projects let in the same contract.

**Standard Operating Instructions:** Instructions for operating CADD applications intended to help guide the user in CADD production activities.

## 4.5 REFERENCES

[Standard Operating System, Topic No. 025-020-002](#)

[Plans Preparation Manual Volume 1 & 2, Topic Nos. 625-000-007/625-000-008](#)

## 4.6 CADD RESOURCES

The *CADD Manual* is maintained by Engineering / CADD Systems Office (ECSO). ECSO updates and distributes the *CADD Manual* in conjunction with CADD Software releases.

## 4.7 STANDARD PROJECT FOLDER

The data for each of the Department’s projects is organized and delivered using a standard Project Folder structure defined in this chapter. The Project Folder (Project Root Folder) must be named the Department’s FPID, using all eleven digits. New projects should be created using tools developed and provided by the ECSO and delivered with the CADD Software Suite. The Department provides an application called *CreateProject* can be used to initiate the Project folder structure. The Department also provides an application *FileChecker* to help confirm the Project folder structure during QC processes.

### 4.7.1 Create Project

The *Create Project* application creates the Project Folder structure and prompts the user for additional project specific information. The project folder contains standard sub-folder names for defined disciplines along with support and resource files specific to the project.

Digital Delivery allows unused sub-folders of the project folder to be deleted if they remain empty. Sub-folders have a purpose for the file content they will receive. For example, a cell library developed for a specific project has a dedicated holding sub-folder named \Cell\ in the standard project folder structure. The \\_meta\_info\ sub-folder is used by the FDOT Workspace to establish the top level of the project folder structure and for other purposes.

**Note** An exception - Specifications Only Projects do not have a \\_meta\_info\ sub-folder. See Section 4.28.

### 4.7.2 Standard Project Folder Structure

The Department’s standard project folder structure and file naming conventions are based on the anticipated workflow of the Department’s projects and the usual separation of work. Digital Delivery allows any unused (empty) sub-folder to be deleted with the exception of the \\_meta\_info\ sub-folder.

The following table displays the standard project folder structure with a descriptive purpose:

Folder Names	Purpose
Project Name (FPID)	Root Project Folder: contains fpid-PLANS.PDF
\_meta_info\	Files used by the FDOT Workspace
\_Shortcuts\	Data shortcuts (data for Civil 3D projects only - not used by MicroStation)
\3DDeliverables\	Copies of specific Design Files for Contractor convenience for 3D models, includes LandXML files of critical geometrics and surfaces
\admin\	Administrative documents (email, correspondence, etcetera)
\eng_data\	Typically contain QC reports
\arch\	Architectural design files
\eng_data\	Typically contain QC reports
\brinspect\	Bridge Inspection files
\eng_data\	Typically contain QC reports
\calculations\	Excel files, PDF files and any associated quantity backup data for the Plan Summary Boxes for Roadway and Structures

Folder Names	Purpose
\Cell\ (or \Block\)	Project specific cell libraries (or project block libraries created for Civil 3D)
\concepts\	Various preliminary concepts
\eng_data\	Typically contain QC reports
\const\	Construction files (i.e.: "As-Builts")
\eng_data\	Typically contain QC reports
\data\	Project data files (i.e.: journals, material backgrounds for rendering, pen tables, print configuration files, etcetera)
\drainage\	Drainage design files
\eng_data\	Typically contain QC reports and calculations
\emo\	Environmental Management files
\eng_data\	Typically contain QC reports
\estimates\	Estimates files
\eng_data\	Typically contain QC reports
\geotech\	Geotechnical data files
\eng_data\	Typically contain QC reports
\GIS\	Geographic Information System Deliverables
\ITS\	Intelligent Transportation Systems design files
\eng_data\	Typically contain QC reports
\landscp\	Landscape design files
\eng_data\	Typically contain QC reports
\lighting\	Lighting design files
\eng_data\	Typically contain QC reports
\maint\	Maintenance department (This is not Maintenance of Traffic).
\eng_data\	Typically contain QC reports
\material\	Other Materials data files
\eng_data\	Typically contain QC reports
\out\	Other miscellaneous Output files
\permits\	Permits for various items (i.e.: ponds, driveways, mailboxes, etcetera)
\eng_data\	Typically contain QC reports
\planning\	Planning files
\eng_data\	Typically contain QC reports
\preestim\	Preliminary estimates files
\eng_data\	Typically contain QC reports
\roadway\	Roadway design files
\eng_data\	Typically contain QC reports
\rwmap\	Right of Way Mapping files
\eng_data\	Typically contain QC reports
\seed\	Project specific seed files
\signals\	Signalization design files
\eng_data\	Typically contain QC reports
\signing\	Signing and Pavement Marking design files
\eng_data\	Typically contain QC reports
\specs\	Source files used to create the Specifications Package*
\eng_data\	Typically contain QC reports
\struct\	Structure design files
\eng_data\	Typically contain QC reports
\survey\	Survey database and surveying design files
\eng_data\	Typically contain QC reports
\symp\	Project specific resource files for fonts and custom line styles
\trafops\	Traffic Operations data files
\eng_data\	Typically contain QC reports
\utils\	Utility data and design files
\eng_data\	Typically contain QC reports



#### 4.7.2.1 Calculations Project Folder

This Project sub-folder contains the Excel summary box templates and custom spreadsheets, PDF or TIFF files of hand drawn sketches and calculations, PDF files generated from other programs (i.e. Mathcad), and any associated *quantity backup data* for the Plan Summary Boxes for Roadway and Structures.

Subfolders specific for Roadway and Structures may be created under the \Calculations\ sub-folder to aide in organization of documentation. Under the Project \Calculations\ Structure sub-folder, separate sub-folders may be created for each bridge and/or structure in the project.

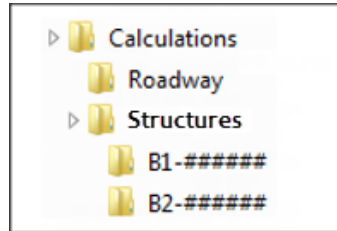

#### 4.7.2.2 Discipline Sub-Folders

Discipline sub-folders of a project are generally defined for the division of work and the files they typically would contain. Roadway designers would typically place files they create and “own” under the \Roadway\ sub-folder of the project, Surveyors under the \Survey\ sub-folder, and so forth. In some cases, disciplines may have work that overlaps with other areas of a design. For example, if a Roadway designer develops the drainage sheets, the files produced would, by the above convention, go in the \Roadway\ folder rather than the \Drainage\ folder as the “Roadway” designer is the owner of the work. However, if so desired, those files could have been put in the \Drainage\ sub-folder instead, but file management permissions (for access control systems such as Vault, ProjectWise, Falcon/DMS, and etcetera) must be taken into consideration.

##### ➤ Engineering Data Sub-Folders:

Each discipline sub-folder contains an additional sub-folder named \eng\_data\. These sub-folders are designated to hold the QC reports (produced by the QC tools) and certain other files.

**Note** Plan sheets are not required to be printed to the \eng\_data\ sub-folder, but may instead be printed directly to a multi-sheet PDF of the plans (stored in the root folder of the project). Remember that empty sub-folders can be deleted in Digital Delivery.

##### ➤ Custom Sub-Folders:

In some cases, it is desirable to create “non-standard” or custom sub-folders for additional segregation of work. This is common when multiple parties work in a single discipline. In these cases, the data must be managed, especially when subdivision of the files into additional sub-folders just makes sense. These additional sub-folders can be created under the discipline standard project sub-folders to accommodate these circumstances, but must not to be created under the root folder for the project. These custom sub-folders must adhere to the restrictions for sub-folder names as defined below:

- Certain special characters are not recognized by some programs for sub-folder names and must be avoided (even if they are valid characters for Windows folder names).
- Alphanumeric characters (a-Z), dashes (-), and underscores (\_) are therefore the only permissible characters for sub-folder names.
- Spaces must not to be used in any folder or file name for the Department projects.
- Sub-folder names must not exceed 16 characters. File names may exceed 16 characters, but should be kept as concise as possible to help meet full path length restrictions.

**Note** Examples of characters that should NEVER be used in sub-folder (or file) names include the characters: &, %, |, \$, ?, <, >, !, even if permissible by the Windows Operating System). Some characters represent escape sequences to certain programs and will cause problems.

- Full path lengths are also generally limited to 1024 characters (or less) total by some software. Overall path length (path plus filename) must be taken into account when creating folders (and file) names and may limit the number of sub-folder levels below the project level folder.

**Note** Remember that the computer (or application) must resolve the full Universal Naming Convention (UNC) path length, even if you have a deep path mapped to a logical drive letter - which could exceed the full path length character limit for some applications. Try to keep your custom folder and file names as concise as possible.

## 4.8 STANDARD FILE NAMES

This section describes the file naming convention for design files. In the event a particular file name is needed for the project and is not addressed by the schema, consult with either the Project Manager or the District CADD Manager to determine the proper filename to use.

The Department also identifies standard design files as either “critical” or “non-critical.” Critical files are frequently used in downstream applications, shared across disciplines, and used in quantifying pay items. These “critical” files must meet a minimum compliancy for CADD symbology. Standard filenames are discipline specific and are detailed within the respective discipline sections later in this manual. Filename special character restrictions have already been introduced.

### 4.8.1 Standard Design File Naming Convention

The Department utilizes standard naming conventions for design files and provides applications that depend on these naming conventions being met. The naming convention also confers information to downstream users about the data contained in the design file.

➤ *Standard design file names follow this format: AAAABB##.ext*

**AAAA** = Abbreviated File Description, which is defined later for most common types  
**BB** = Discipline *Designation*,  
**##** = A file Sequence Number (*a padded integer, i.e. “00”, “01”, “02” ... “99”, used to sequence additional files of the same Description + Denotation*),  
**.ext** = File extension indicating the type of file.

For Example: The first proposed Roadway cross section file would be named: *rdxsr01.dgn*

The first six (6) characters of the standard design file naming convention described above are also critical triggers for QC software and symbology filters. If it is necessary to add additional descriptive information in the design filename, this descriptive information should be inserted after the discipline denotation “BB” and preceding the sequence number “##”. Doing so should be only on rare occasion.

For Example: *rdxsr-rampA-01.dgn*, might indicate this proposed cross section file includes Ramp A.

Very large projects might also necessitate the need to exceed two digit sequence numbers (100+); otherwise the sequence should be limited to two digits. The Department delivers a *CreateFiles* application to assist in producing Design files with the standard naming convention.

**Note** See Discipline Sections 4.13 – 4.28 of this document for comprehensive coverage of design file naming conventions and CADD Standard Rule assignment applicable to each discipline. See Appendix A for the complete listing of level/symbology standards for each applicable CADD Standard Rule.

## 4.8.2 Print Image File Naming Convention

MicroStation projects use the application *Sheet Navigator* to extract the sheet and title block data from design files containing sheets. The source design file name and data extracted from those files yields resulting PDF print file names (and defines the sheet's relationship to the plans component of the project). Sheet Navigator uses the *SheetInfo.xml* control file to determine the component order for sheets in the plans set, mining their location in the project folder structure and the sheet number prefix. The *Sheetinfo.xml* control file defines the standard search criteria to identify sheets in a project and is located in the CADD Software \mdlapps\ sub-folder.

AutoCAD Civil 3D projects use a similar tool called *Sheet Set Organizer (SSO)*. SSO also uses the source design file name and data extracted from the sheet layouts in drawings assigned to AutoCAD's Sheet Set Manager (.dst) files for names and organizes plans components of the project.

PDF files are the required format for producing an electronic image of Plans for Digital Delivery. Multi-sheet PDF files representing Plans and / or Specifications have been ruled acceptable to the Boards of Professional Regulation and may be signed and sealed with a single or multiple digital signatures. Provisions were made to resolve any potential ambiguity regarding who is responsible for content by using a Signature Sheet (see the Department's PPM, Volume 2, Chapter 3) for each file signed with a Digital Signature. If more than one professional must sign any given file, a Signature Sheet must appear in that Plans Set (or Component Set) to bear the appearance of each Signatory and include a definition of the portions of that Set each Signatory is taking responsibility for. Data producers are no longer required to retain or sign single files representing each individual sheet of a Plans set.

### 4.8.2.1 Sheet Numbers

Sheet numbers used in the title blocks of plan sheets are composed of multiple parts using the syntax: **AAA-####Z**.

Example Sheet Numbers: S-001A, S-001B, PNC-01, A-15, A-16, T-1, T-2, and 1, 2, 3, etcetera.

- **AAA** - Represents the sheet number prefix, using multiple alpha characters. Refer to the [Plans Preparation Manual](#) and [Structures Manual](#).
- **####(Z)** - Defines the numeric order of the sheets within the Plans Component. The optional (Z) suffix allows for the insertion of appended sheets after the project has started, such as the case during revisions. Prior to the first revision, designers should renumber sheets avoiding use of suffixes. A single alpha character suffix, A-Z, is added for each subsequent sheet inserted for a revised sheet.

**Note** Structures and Architecture disciplines have extended the sheet numbering schema and the respective discipline instructions should be consulted for additional guidance. These are found in their respective sections later in this Manual.

*Sheet Navigator* uses sheet number prefixes to determine the plans component each sheets belongs to. The following table identifies each sheet number prefix.

<b>Prefix</b>	<b>Component</b>
[No prefix]	Roadway Plans - (Typical - only an integer is used for most of these sheet numbers)
CTL	Roadway Plans - Project Survey Control Sheets
GR	Roadway Plans - Soil Survey and Report of Core Borings
SQ	Roadway Plans - Summary of Quantities
TR	Roadway Plans - Tree Survey Sheets
UTV	Roadway Plans - Verified Utility Locate Sheets
IT	Intelligent Transportation System (ITS) Plans
GI	Intelligent Transportation System (ITS) Plans - Soil Survey and Report of Core Borings
LD	Landscape Plans
L	Lighting Plans
GL	Lighting Plans - Soil Survey and Report of Core Borings
PNC	Project Network Control Sheets
T	Signalization Plans

PTM	Signalization Plans - Portable Traffic Monitoring Site Sheets
GT	Signalization Plans - Soil Survey and Report of Core Borings
S	Signing and Pavement Marking Plans
GS	Signing and Pavement Marking Plans - Soil Survey and Report of Core Borings
Begins with "A"	Architectural Plans
Begins with "B"	Structures Plans
Begins with "U"	Utility Work by Highway Contractor Agreement Plans

Roadway plans are typically the primary component of the Department’s project plans set containing multiple plan components and can have non-prefixed sheet numbers (1, 2, 3, etcetera). Other disciplines can also be the primary plans component - only in the absence of a Roadway plan component. For example: A Lighting only project may omit the plans component prefix and use the numbering format of 1, 2, 3, etcetera, although this practice is strongly discouraged.

**4.8.2.2 Print Image File Naming Format**

Applications that support printing, such as *Sheet Set Organizer* implement a file naming scheme for PDF files it manages that removes ambiguity about which sheet the file represents (regardless of the sheet-numbering scheme used in the design file) and supports more complex sheet numbering being expected by some disciplines. Digital Delivery does not require individual sheet image files to be delivered, however. If individual sheets are printed to PDF and retained, they must follow the naming convention shown below:

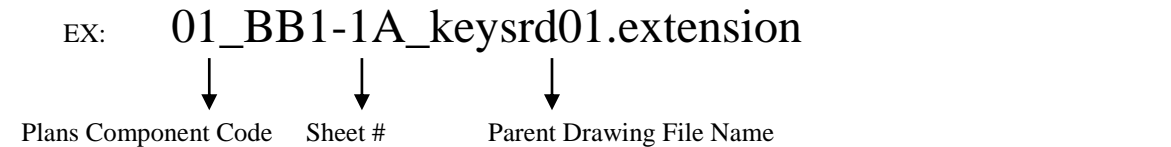

**Note**      Image file extension must be "PDF" (Portable Document files) and "TIF" (Tagged Image Format files).

- Plans Component Code - [01] The first two numbers represent the Plans Component with zero (0) padding (for file name sorting purposes).

The Department’s Standard Plans Component codes (corresponding to the PPM components) are as follows:

- 01 – Roadway Plans
- 02 – Signing and Pavement Marking Plans
- 03 – Signalization Plans
- 04 – Intelligent Transportation System (ITS) Plans
- 05 – Lighting Plans
- 06 – Landscaping Plans
- 07 – Architectural Plans
- 08 – Structures Plans
- 09 – Utility Work by Highway Contractor Agreement Plans
- 10 – Right of Way Maps
- 11 – Utility Joint Participation Agreement Plans
- 12 – Toll Facility Plans
- 99 – Unknown (used by *Sheet Navigator* if it cannot determine the Plans Component)

- Sheet # - After the Plans Component Code, an underscore ( \_ ) is inserted as a separator, followed by the actual sheet number (BB1-1A) appearing in the title block of the sheet.
- Parent Drawing File Name - After the Sheet #, an underscore ( \_ ) is inserted as a separator followed by the name of the source design file (keysr01).

### 4.8.3 Typical File Name Extensions

Extension	File Description	Saved-in Folder
.3pc	3 Port Criteria Files	Most appropriate discipline folder
.pdf	Files for the PLANS	Root project folder for <i>fpid</i> -PLANS.pdf for Digital Delivery.
.pdf	Files for the SPECS	\specs\ sub-folder for <i>fpid</i> -SPECS.pdf
.dxf	AutoCAD ASCII Drawing Interchange File	Most appropriate discipline folder
.dwg	AutoCAD Design Files	Most appropriate discipline folder
.dst	AutoCAD Drawing Sheet Set	\eng_data\ sub-folder for the discipline
.dwt	AutoCAD Drawing Template	\seed\ sub-folder of the project
.lin	AutoCAD Linetype	\symb\ sub-folder of the project
.pc3	AutoCAD Printer Configuration	Most appropriate discipline folder or \symb\ sub-folder of the project
.shx	AutoCAD Shape Compiled	\symb\ sub-folder of the project
.shp	AutoCAD Shape Files are ASCII Files	\symb\ sub-folder of the project
.stb	AutoCAD Plot Style Tables	Most appropriate discipline folder or \symb\ sub-folder of the project
.csv	Comma Separated Values	Most appropriate discipline folder
.gpk	Coordinate Geometry Database Files	Most appropriate discipline folder
.alg	Corridor Modeling Alignment Database	Most appropriate discipline folder
.xlp	Corridor Modeling Cross Section Labeling Preference File	Most appropriate discipline folder
.xin	Corridor Modeling Drafting Standards	Most appropriate discipline folder
.rdp	Corridor Modeling Roadway Design Preference File	Most appropriate discipline folder
.ird	Corridor Modeling Roadway Designer Database	Most appropriate discipline folder
.dtm	Corridor Modeling Surface Database	Most appropriate discipline folder
.itl	Corridor Modeling Template Library	Most appropriate discipline folder
.hmr	Descartes Raster Image Files	Most appropriate discipline folder
.gpk	GEOPAK COGO Database	Most appropriate discipline folder
.x	GEOPAK Criteria Files	Most appropriate discipline folder
.ddb	GEOPAK D&C Manager Database Files	Most appropriate discipline folder
.gdf	GEOPAK Drainage File	Most appropriate discipline folder
.dlb	GEOPAK Drainage Library	Most appropriate discipline folder
.inp	GEOPAK Input Files	Most appropriate discipline folder
.prj	GEOPAK Project Manager Project File	Most appropriate discipline folder
.tin	GEOPAK Surface Database	Most appropriate discipline folder
.gif	Graphics Interchange Format	Most appropriate discipline folder
.jpeg, .jpg	Joint Photographic Experts Group	Most appropriate discipline folder
.log	Log File	Most appropriate discipline folder
.xls(x)	Microsoft Excel Spreadsheets	Most appropriate discipline folder
.doc(x)	Microsoft Word Documents	Most appropriate discipline folder
.rsc	MicroStation & GEOPAK Resource Files	\eng_data\ sub-folder for discipline
.cel	MicroStation Cell Libraries	\cell\ sub-folder of the project folder
.dgn	MicroStation Design Files	Most appropriate discipline folder
.tbl	MicroStation Pen Tables	\eng_data\ sub-folder for discipline

Extension	File Description	Saved-in Folder
.plt	MicroStation Print Drivers	\eng_data\ sub-folder for discipline
.pset	MicroStation Print Organizer Print Set	Most appropriate discipline folder
.pcf	MicroStation Project Configuration	Project Root folder
.dgnlib	MicroStation Standards Database	\syml\ if copied to local project
.sid	Multi-resolution Seamless Image Database	Most appropriate discipline folder
.ps	Postscript Sheet Image Files	\eng_data\ sub-folder for discipline
.xcp	QC Exception Files	\eng_data\ sub-folder for discipline
.txt	QC Reports, QC "Folder Name"	\eng_data\ sub-folder for discipline
.tif	Tagged Image File	Most appropriate discipline folder
.htm, .html	Web Pages	Project Root folder and \data\ sub-folder
.xml	XML Files	Most appropriate discipline folder

### 4.8.4 Duplicate Files

There must not be duplicate CADD (.DGN, DWG, etcetera) design file names within a project folder structure. This is necessary to ensure proper reference attachments in CADD files. The *FileChecker* application can be used to help find duplicate filenames within the project folder structure.

**Note** MicroStation and AutoCAD, as part of their search sequence, will use the first occurrence of a file name found as they traverse a folder structure looking for reference attachments with no paths.

Duplicate file names for source attachments can “corrupt” data references. Always use the “relative path” option, but never “full” or “no path” when attaching references.

## 4.9 REFERENCE FILES

A reference file can be many file types, such as a MicroStation design file, an AutoCAD design file, a raster image file (such as a SID, TIF, or HMR), or a PDF. A reference file is attached as a “background file” to an active design file being edited, thus allowing multiple users to share the information in the reference file without the need to copy the reference file(s) into the active design file folder (creating unnecessary and prohibited duplicates), or copy the referenced file’s content into the active design file.

**Important** Under no circumstances should the “absolute” or “full path” be used when attaching a reference file. Use relative referencing - always! All reference files for the project must reside within the project folder structure.

In MicroStation, reference paths are managed by an application setting (FDOTConfig) that is run at startup of any MicroStation file opened in the FDOT Workspace. This application looks for the \\_meta\_info\ folder and then moves up one folder to set the root folder for the project. It then dynamically sets the MicroStation configuration variable, MS\_RFDIR, to search downward from the root folder through all found sub-folders to identify any reference files. Therefore all design files for a project must reside within the Department’s standard folder structure or its sub-folders in order to be located as a reference file.

In AutoCAD Civil 3D, there are two types of reference files used:

- X-references (X-Ref) (Design files)
- Data References (D-Ref) (Data shortcut files located in the \\_shortcuts folder within a project)

If the \\_meta\_info\ subfolder does not exist, when a file is opened in MicroStation in an FDOT Workspace, the user will be prompted to define the parent folder of the project to enable the application to set the search path for reference files. See the following screenshot:

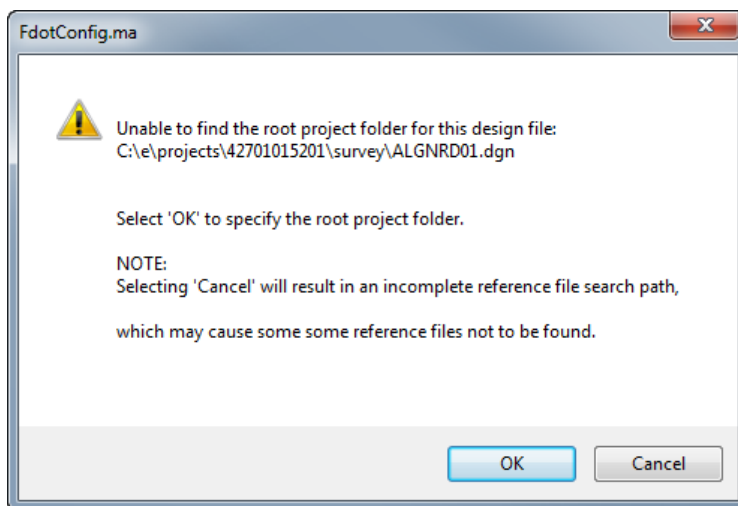

- If Cancel is selected, any reference to the models of files located in different sub-folders will not be displayed because the MS\_RFDIR variable could not be populated automatically.
- If OK is selected, the user will be given the opportunity to define the root of the project. The user navigates to the root of the project, named for the Financial Project Identification Number.

**Important:** If duplicate file names exist in the sub-folders of the project, MicroStation will attach the first matching filename it finds in the path. Therefore, duplicate file names are prohibited!

## 4.10 SHARING CADD FILES BETWEEN DISCIPLINES

There are times when disciplines share files with other disciplines. If a discipline requires information from another discipline, the needed design file(s) or individual models must be referenced from the original folder, not copied.

For example, the Signing and Pavement Marking design file (*DSGNSP*) references the Roadway design file (*DSGNRD*) and the Topography file (*TOPORD*). These files should not be copied into the Signing and Pavement Marking discipline sub-folder.

**Note** If there is a specific justification to copy a file into another folder, the filename must be modified to reflect the discipline file name usage. For example, *topord01.dgn* (from the \survey\ sub-folder) would become *toposp01.dgn*, if copied to the \signing\ sub-folder, or as a minimum the sequence number would change to ensure that there is no doubt the copied file differs from the original source file.

The data producer is always responsible to ensure that up-to-date content of the original files is always reflected in their copies of those design files. Making copies of design files to different locations is strongly discouraged for this reason, as the content now must be managed between the originals and the copies.

## 4.11 PROJECT JOURNAL

A Project Journal must be produced for all projects to document details on project data, design aspects, processes and decisions made during the development that would communicate important information to a down-stream user of the project data. The Journal must be delivered with the Project in either MS Word (.doc or .docx), text (.txt), or Acrobat (.pdf) formats.

The Project Journal file(s) may be delivered to document the activities for a given discipline (i.e. a Surveyor's Journal), or may be created to document a particular production activity (i.e. creating cross sections). Journal file entries should document alternate methods employed, variant decisions made, problems encountered, setting selected, fixes included or other issues encountered during the production process outside the normal course of operations.

For example: If custom line styles were created, the justification for the custom line style and the resource file name containing the custom line style should be documented in the Journal. Any information that would help in the regeneration of CADD files and / or prints should be recorded. The critical geometry information, database, controlling alignment(s) and profile names, relevant survey and cross section information and the methodology used to obtain the final geometric controls in the CADD product should be recorded.

## 4.12 PRINTS

All printing will be generated from the native design files. All print images (PDFs) are produced to scale to match the native application.

**Note** Not all printer hardware will print paper sheets exactly to scale, even if the source design file, or a resulting print image file (PDF) is to scale.

The Department's standard sheet borders are defined for the disciplines. Sample print drivers are also provided to generate "drawn to scale" print images for the printer hardware supported. Standard sheet borders delivered with the CADD software comply with the Department's sheet appearance formats, as defined in the PPM and other controlling procedures.

### 4.12.1 Print Borders

For MicroStation printing, the Department's standard sheet files have a print border embedded for each sheet. The defined search criteria for constituting a print area on a sheet is illustrated in the table below.

**Note** *PlotBorder\_dp* and *ShtPlotBorder\_c* are the current print border level symbology used in the CADD Software. Typical print border dimension for 11x17 plan sheet prints: 16.5" x 10.6".

	Border 1	Border 2	Border 3	Border 4	Border 5
Type	Shape	Shape			Shape
Level	PlotBorder_dp	PlotBorderSht	PlotShape	ShtPlotBorder_c	51
Color	BYLEVEL	BYLEVEL	BYLEVEL	BYLEVEL	3

For AutoCAD printing, the Department prints sheets defined in Layout tabs, no search criteria is required.

### 4.12.2 Print Image Files

The PDF print capability provided by both Bentley and Autodesk is the required print format for plans. When PDF files are produced, the user must ensure that no encryption or other PDF security is embedded in the PDF so those print files may be subsequently manipulated (such as rotation to proper viewing orientation, combining into larger multi-page PDF documents, or digitally signing and sealing later in the production process). Note that once a file is digitally signed and sealed, it cannot be manipulated later without invalidating the signatures already applied.



## 4.12.3 Foreign Plan Sheets

In some cases, designers have no choice but to scan pre-existing hardcopy sheets to create digital sheet files. For example, some plan sheets may already exist as hardcopies and were signed & sealed conventionally by wet ink signature and impression seal at some time in the past. This might occur when either pre-existing plans are incorporated into the current delivery, or some professional discipline does not have legal authority to sign and seal their plans digitally. In such cases, those plan sheets should be scanned at minimum of 300 DPI resolution (or higher if warranted), to PDF, or Group-4 Tagged Image File Format (TIFF), according to [State of Florida Electronic Records and Records Management Practices](#). When scanning, use the lightest contrast setting possible such that reprints from the scans have a minimum of scanned “artifacts” and “speckling,” and will read and print legibly.

**Note** File naming of the scanned sheet files should follow the file naming conventions already described.

If scanning hardcopy plans that bear a raised seal, then the raised seal should be shaded / burnished before scanning so the seal appears clearly in the scanned image. Scanned existing plan sheets already signed and sealed on paper must not be re-signed and sealed with Digital Signature. However, they may be signed-only (not sealed) by a responsible party only to take accountability for their inclusion within a contemporary plans set (using the appropriate qualifiers or exculpatory language).

## 4.12.4 Print Drivers

The example print driver files and the sheet settings provided with the CADD Software are used to generate prints to scale. These driver files are considered “examples,” due to the various site-specific configurations and types of printers that may be encountered. The print driver files were tested and work with the printers for which they were developed, so one may have to make adjustments if their equipment varies.

Each printer has its own “printable” area defined for a paper size which may differ slightly from printer model to printer model. It is the sole responsibility of the person performing the prints to ensure hardcopy printing is operating acceptably for their hardware. All MicroStation print driver files supplied by the Department have raster printing enabled. AutoCAD uses Page Setups and Plot Style tables.

**Note** See Section 3.10 of this document for a list of MicroStation print driver files delivered by the Department.

### 4.12.4.1 MicroStation Half-Toning

The color 20 is used to define half-toning in the Department’s MicroStation printer driver files. Half-toning of the minor grid lines on the cross section sheets, the profile portion of the plan / profile sheet and the profile sheet is shown in the *PPM, Volume 2 Exhibits*. The Department’s Project Manager must approve half-toning of any other graphical elements in the design files.

Some Districts have specified half-toning of certain reference files from one discipline to another. For example, the topography file could be half-toned when referenced to the proposed design. This must be approved on a per District basis. A pen table can be set up to equate any referenced file to color 20, thus half-toning the entire reference file at print time.

### 4.12.4.2 Quality and Reproduction

Printed output from the design files or plan sheet image file PDF’s must be legible and of a quality to be reproducible on 2<sup>nd</sup> generation copies. Line weights as defined in Chapter 3 are default settings, but may need to be adjusted, depending on printer hardware, to produce the required quality of hard-copy printed documents.

## 4.12.5 Professional of Record Note

For those sheets that are digitally signed and sealed by a Professional Engineer, the following note must be placed legibly on the sheet, typically along the right hand border of the sheet opposite of the binding location:

**Note** See the PPM; Volume 1, Section 19.2.2, for further information.

“NOTICE: THE OFFICIAL RECORD OF THIS SHEET IS THE ELECTRONIC FILE DIGITALLY SIGNED AND SEALED UNDER RULE 61G15-23.004, F.A.C.”

**Note** For additional information about Professional of Record Note and Signature Sheets also see the PPM; Volume 2, Chapter 3.

The regulatory Board Rule number referenced is determined by the discipline of the professional that is signing and sealing (i.e., for Surveyors and Mappers, the Rule is 5J-17.062, F.A.C. For Geologists, the Rule is 61G16-2.005, F.A.C. For Landscape Architects, the Rule is 61G10-11.011, F.A.C. For Registered Architects, the Rule is 61G1-16.005, F.A.C.).

Sheets that are signed by multiple Signatories of different professional types (such as an Architect and an Engineer) will not bear the note unless it can be combined and fit legibly on the border. In such a case the note might read:

“NOTICE: THE OFFICIAL RECORD OF THIS SHEET IS THE ELECTRONIC FILE DIGITALLY SIGNED AND SEALED UNDER RULE 61G15-23.004, F.A.C., AND RULE 61G1-16.005, F.A.C.”

Signatory Sheets have similar notes placed within the body of the sheet within the section for each Signatory, and will not have the note placed along the sheet border. See examples in the PPM, Volume 2 Chapter 3.3.

The Professional of Record Note may be placed on the sheet at any time during the plans production process, however has no force or effect until the sheet is actually signed and sealed.

## 4.13 RIGHT OF WAY (R/W) MAPPING STANDARDS

This chapter will describe the minimum CADD requirements for R / W Mapping operations.

### 4.13.1 Standard File Names

The Department utilizes standard naming conventions for all of its files and provides automated tools that depend on this naming convention. The naming convention confers data information to the downstream customer.

Standard file names should follow this format: AAAABB##.ext

Where **AAA** = abbreviated file description, **BB** = Discipline Denotation, ## =Sequence number.









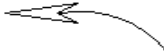

The following table defines the R/W Mapping File Name Standards Name with each file including sequential numbering. Standard Model names are also provided, however, it is not mandatory to use more than the default model.



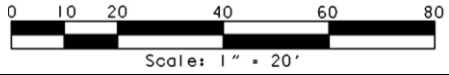
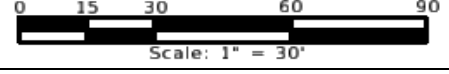
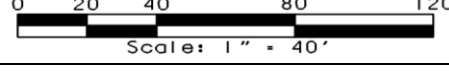
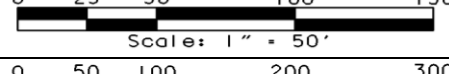
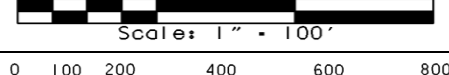
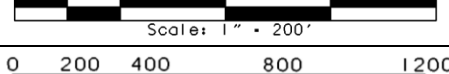
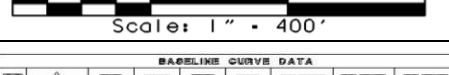
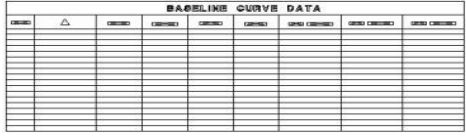









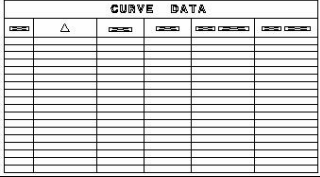

*Note* See Section 4.8 of this document for more information about Standard File Names. See Appendix A for the complete listing of level / symbology standards for each applicable CADD Standard Rule.

Critical	File Name	Model	File Description	Rule File	MicroStation Seed File	Civil 3D Template File
	CS%>%>%>%%##	default	Control Survey Master Design File (%...% Enter 7 digit No.)	rweng10	rwseed2d.dgn	rweng10.dwt
X	CSCOVR##	default	Control Survey Cover Sheet	rweng10	rwseed2d.dgn	CSCOVR.dwt
X	CSDETL##	default	Control Survey Detail Sheet	rweng10	rwseed2d.dgn	CSDETL.dwt
X	CSKEYM##	default	Control Survey Key Map Sheet	rweng10	rwseed2d.dgn	CSDETL.dwt
	CTLSRD##	default	Survey Project Network Control Sheets	open	rwseed2d.dgn	CTLSRD.dwt
	MM%>%>%>%%##	default	Maintenance Map Master Design File (%...% Enter 7 digit No.)	rweng10	rwseed2d.dgn	rweng10.dwt
X	MMCOVR##	default	Maintenance Map Cover Sheet	rweng10	rwseed2d.dgn	MMCOVR.dwt
X	MMDETL##	default	Maintenance Map Detail Sheet	rweng10	rwseed2d.dgn	MMDETL.dwt
X	MMKEYM##	default	Maintenance Map Key Map Sheet	rweng10	rwseed2d.dgn	MMDETL.dwt
	RW%>%>%>%%##	default	R / W Master Detail Design File (%...% Enter 7 digit No.)	rweng10	rwseed2d.dgn	rweng10.dwt
X	RWCOVR##	default	R / W Cover Sheet	rweng10	rwseed2d.dgn	RWCOVR.dwt
X	RWDETL##	default	R / W Detail Sheet	rweng10	rwseed2d.dgn	RWDETL.dwt
X	RWFACS##	default	R / W Cover Sheet FA Project	rweng10	rwseed2d.dgn	RWCOVR.dwt
X	RWKEYM##	default	R / W Key Map Sheet	rweng10	rwseed2d.dgn	RWDETL.dwt
X	RWPNECTAB##	default	R / W Project Network Control Tabulation Sheet	rweng10	rwseed2d.dgn	RWDETL.dwt
X	RWPS##	default	R / W Parcel Sketch Sheet (8.5"x11" Portrait)	rweng10	rwseed2d.dgn	RWPS.dwt
X	RWSPS##	default	R / W Specific Purpose Survey Sheet	rweng10	rwseed2d.dgn	RWSPS.dwt
X	RWTAB##	default	R / W Tabulation Sheet	rweng10	rwseed2d.dgn	RWTAB.dwt
	SIGNRW##	default	Digital Signatures	rweng10	rwseed2d.dgn	digitalsignature.dwt
	TOPORW##	default	ROW Mapping File Containing Existing Topography for Mapping Purposes Only	open	rwseed2d.dgn	TOPORW.DWT

### 4.13.2 R/W Cell Library

**Note** R / W cell library is ROW.CEL. R / W cells must be placed with the True Scale toggle set to "ON".

ELEMENT	TYPE	SYMBOL	Macro
ARROW TERMINATOR LEFT (Place on ByLevel of Text Element Relative Toggle "ON")	C = ARRWLG		Place Delineator
ARROW TERMINATOR RIGHT (Place on ByLevel of Text Element Relative Toggle "ON")	C = ARRWLG		Place Delineator
LINE TERMINATOR@POINT G = Graphic type cell	C =ARRLT		Place Delineator
LINE TERMINATOR@POINT G = Graphic type cell	C =ARRRT		Place Delineator
BAR SCALE 1" = 20'	C = BS20		Place Bar Scale
BAR SCALE 1" = 30'	C = BS30		Place Bar Scale
BAR SCALE 1" = 40'	C = BS40		Place Bar Scale
BAR SCALE 1" = 50'	C = BS50		Place Bar Scale
BAR SCALE 1" = 100'	C = BS100		Place Bar Scale
BAR SCALE 1" = 200'	C = BS200		Place Bar Scale
BAR SCALE 1" = 400'	C = BS400		Place Bar Scale
BASLINE CURVE DATA BOX (Used with GEOPAK Table Tutorial)	C = BLBOX		
BASLINE SYMBOL	C = BL		
CENTERLINE SYMBOL	C = CL		
Block Number Double	C= BLOCKNUMBERD		
Block Number Single	C= BLOCKNUMBERS		
CONCRETE MONUMENT OPEN	C = MONSQ		
CONCRETE MONUMENT SOLID	C = MONSQS		

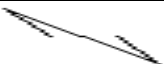
ELEMENT	TYPE	SYMBOL	Macro
CONCRETE R / W MONUMENT (R/W MONUMENTATION MAP)	C = MON		
COORDINATE DATA BOX (Used with GEOPAK Table Tutorial)	C = COORD		
CURVE DATA BOX (Used with GEOPAK Table Tutorial)	C = CURBOX		
CURVE DATA (English) (Used with GEOPAK Table Tutorial)	C = CDATA	CURVE P.I. STA. Δ = D = T = L = R = P.C. STA. P.T. STA.	
NORTH ARROW	C = NOARR		
PARCEL BUBBLE 100	C = PB100		
PARCEL BUBBLE 700	C = PB700		
PARCEL BUBBLE 800	C = PB800		
PARCEL BUBBLE 900	C = PB900		
PERMANENT R / W MONUMENT (R / W MONUMENTATION MAP)	C = PRWM		
PROPERTY LINE HOOK	C= PLHOOK		
PROPERTY LINE HOOK	C= PLHTOP		
PROPERTY LINE HOOK	C =PLHBOT		
PROPERTY LINE SYMBOL	C = PL		
ROD MONUMENT OPEN	C = MONRD		
ROD MONUMENT SOLID	C = MONRDS		
SEGMENTED CURVE CHORD DIST. / BEARING (Used with GEOPAK Table Tutorial)	C = SEGCUR	Δ = L = R = C.D. = C.B. =	
SPRING LINE (Place on Symbology of Assoc. Element)	C=SPRING		Place SpringLine

### 4.13.3 Level / Layer and Symbology Standards

Refer to the Standard Rule Tables in Appendix A for the listing of the R / W (RWENG10) elements and their symbology. The list of elements shown may not contain all of the elements that appear within a R / W map, as this list would be extensive. The elements shown are those that are required for specific types of R / W maps.

All R / W Levels are 'Critical' levels, meaning that the attributes: Level, Color, Style and Weight will all be checked for QC compliancy. The exception is for Text levels, where the Style attribute will be set as Non-Critical and excluded from compliance checking.

**Note** R/W elements must match the standard symbology for the R/W file they reside in. Non-R/W elements will be drawn in the symbology of their intended file type. For example: edge of pavement drawn in RWDETL01.DGN would be given the symbology as if drawn for DSGNRD01.DGN. All R/W level symbology must use ByLevel settings.

### 4.13.4 R/W Workspace

The Department's CADD Software incorporates features for R/W Mapping Standards compliance to assist R/W Mapping for Department projects. The *FDOT Right-of-Way Mapping* training manual is also provided to outline these tools and can be accessed from the ECSO website:

<http://www.dot.state.fl.us/ecso/downloads/documentation/RightofWayMapping/RightofWayMapping.shtm>

**Note** FDOT State Kit for AutoCAD Civil 3D includes the same content in the R/W templates.

## 4.14 ENVIRONMENTAL MANAGEMENT STANDARDS

The Environmental Management Office (EMO) has responsibility for the project development phase. The intent is to give latitude and discretion in performing project analysis, project development, preliminary engineering, public involvement and environmental required tasks while maintaining the necessary level of CADD standards for the products of EMO.

The Project Development and Environmental Clearance process is oriented to presenting the project to the permitting and regulatory agencies, politicians and the general public in a format which is clear and easy to understand. Production plans do not become important until after Location and Design Concept Acceptance is obtained. The goal is to create a presentation that is useful to the plans development process, but public presentation is the primary concern.

### 4.14.1 Standard File Names

The Department utilizes standard naming conventions and provides automated tools that depend on this naming convention being met. The naming convention confers data information to the downstream customer.

➤ ***Standard design file names should follow this format: AAAABB##.ext***

Where **AAAA** = abbreviated file description, **BB** = Discipline Denotation, **##** =Sequence number.

**Note** See Section 4.8 for more information about Standard File Names. See Appendix A for the complete listing of level/symbology standards for each applicable CADD Standard Rule.

The following table defines the EMO File Name with each file including sequential numbering. Standard Model names are also provided. Unless otherwise specified, it is not mandatory to use more than the default model.

File Type	Critical	File Name	Model Name	File Description	Standard Rule	MicroStation Seed File	Civil 3D Template File
Borders & Sheets		BDBREM##	default	Border Sheet Reference File for Bridge Hydraulic Sheet	planrd	fdotseed2d.dgn	
Borders & Sheets		BDPLEM##	default	Border Sheet Reference File for Plan Sheet	planrd	fdotseed2d.dgn	
Borders & Sheets		BDPPEM##	default	Border Sheet Reference File for Plan & Profile Sheet	plprrd	fdotseed2d.dgn	
Borders & Sheets		BDPREM##	default	Border Sheet Reference File for Profile Sheet	plprrd	fdotseed2d.dgn	
Borders & Sheets	X	BDXSEM##	rdxsrd	Border Sheet Reference File for Cross-Section Sheet	rdxsrd	fdotseedxs.dgn	
Borders & Sheets		GNNTEM##	default	General Notes	planrd	fdotseed2d.dgn	fdotmaster.dwt
Borders & Sheets		LDPREM##	default	Lateral Ditch Plan / Profile Sheet	plprrd	fdotseed2d.dgn	fdotmaster.dwt
Borders & Sheets		PLANEM##	default	Plan Sheet	planrd	fdotseed2d.dgn	fdotmaster.dwt
Borders & Sheets		PLAYEM##	default	Project Layout Sheets	planrd	fdotseed2d.dgn	fdotmaster.dwt
Borders & Sheets		PLPREM##	default	Plan & Profile Sheets	plprrd	fdotseed2d.dgn	fdotmaster.dwt
Borders & Sheets		PRDSEM##	default	Project Profile Layout	planrd	fdotseed2d.dgn	fdotmaster.dwt
Borders & Sheets		PROFEM##	default	Profile Sheets	plprrd	fdotseed2d.dgn	fdotmaster.dwt
Clipping		CLIPEM##	default	Clip Borders	cliprd	fdotseed2d.dgn	fdotmaster.dwt
Clipping		MTPLEM##	default	Motif file for plan sheets	planrd	fdotseed2d.dgn	fdotmaster.dwt
Clipping		MTPREM##	default	Motif file for profile sheets	plprrd	fdotseed2d.dgn	fdotmaster.dwt
Cross Sections	X	LDXSEM##	rdxsrd Rdxsrd Pattrd Xsshrd	Lateral Ditch Cross-Sections Lateral Ditch Cross-Sections Lateral Ditch Pattern Lines Lateral Ditch Shapes	rdxsrd	fdotseedxs.dgn	rdxsrd.dwt
Cross Sections	X	PDXSEM##	Rdxsrd_shg Rdxsrd Pattrd Xsshrd	Lateral Ditch Cross Section Sheets Pond Cross-Sections Pond Pattern Lines Pond Shapes	pdxsrd	fdotseedxs.dgn	fdotmaster.dwt
Cross Sections	X	RDXSEM##	Rdxsrd_shg Rdxsrd Pattrd Xsshrd	Pond Cross Section Sheets Roadway Cross-Sections Roadway Pattern Lines Roadway Shapes	rdxsrd	fdotseedxs.dgn	fdotmaster.dwt
Existing DTM		GDTMEM##	default	Digital Terrain Model / TIN Model - 3D	gdtmrd	fdotseed3d.dgn	survey.dwt
Existing Topography		TOPOEM##	default	Topography-Existing (Utility & Drainage not included)	topord	fdotseed2d.dgn	survey.dwt
Key Sheets		KEYSEM##	default	Key Sheet	keysht	fdotseedkeymap.dgn	keysht.dwt
Project Network Control		PNCSEM##	default	Survey Project Network Control Sheets	planrd	fdotseed2d.dgn	ctlsrd.dwt
Proposed Design		ALGNEM##	alnrd	Alignment Layout	alnrd	fdotseed2d.dgn	fdotmaster.dwt
Proposed Design		BKSWEM##	default	Back of Sidewalk Profiles	plprrd	fdotseed2d.dgn	fdotmaster.dwt
Proposed Design		CURCEM##	default	Curve or Coordinate Data Sheet	planrd	fdotseed2d.dgn	fdotmaster.dwt

File Type	Critical	File Name	Model Name	File Description	Standard Rule	MicroStation Seed File	Civil 3D Template File
Proposed Design	X	DSGNEM##	default	Proposed Design	dsgnrd	fdotseed2d.dgn	fdotmaster.dwt
Proposed Design		DSPFEM##	default	Proposed Profile	plprrd	fdotseed2d.dgn	fdotmaster.dwt
Proposed Design		GCTREM##	default	Contours 2D	dtmrd	fdotseed2d.dgn	fdotmaster.dwt
Proposed Design		INTDEM##	default	Intersection/Interchange Details	planrd	fdotseed2d.dgn	fdotmaster.dwt
Proposed Design		INTPEM##	default	Intersection/Interchange Profiles	plprrd	fdotseed2d.dgn	fdotmaster.dwt
Proposed Design		MITGEM##	default	Mitigation Areas	planrd	fdotseed2d.dgn	fdotmaster.dwt
Proposed Design		PDPLEM##	default	Pond Design	drprrd	fdotseed2d.dgn	fdotmaster.dwt
Proposed Design	X	QTDESEM##	default	Quantity Computation Shapes/Calculations	qtdsrd	fdotseed2d.dgn	fdotmaster.dwt
Proposed Design	X	QUANEM##	default	Quantity Computation Details	qtdsrd	fdotseed2d.dgn	fdotmaster.dwt
Proposed Design		RWDTEM##	default	R/W Details for Roadway	rwdtrd	fdotseed2d.dgn	rwdtrd.dwt
Proposed Design		SCGREM##	default	Selective Clearing & Grubbing Sheet	planrd	fdotseed2d.dgn	fdotmaster.dwt
Proposed Design		SIGNEM##	default	Digital Signatures	open	fdotseed2d.dgn	digitalsignature.dwt
Proposed Design		SWPPEM##	default	Storm Water Pollution Prevention Plan	planrd	fdotseed2d.dgn	fdotmaster.dwt
Proposed Design		TEXTEM##	default	Text Labels & Miscellaneous Descriptions	planrd	fdotseed2d.dgn	
Proposed Design		WETLEM##	default	Wetlands Delineation Sheet	planrd	fdotseed2d.dgn	fdotmaster.dwt
Special Details		SPDTEM##	default	Special Details Sheet	open	fdotseed2d.dgn	fdotmaster.dwt
Summary Boxes / Tables		BRHYEM##	default	Bridge Hydraulics Recommendation Sheet	planrd	fdotseed2d.dgn	fdotmaster.dwt
Summary Boxes / Tables		BXCLEM##	default	Box Culvert Wingwall Design & Special Details	drdtrd	fdotseed2d.dgn	fdotmaster.dwt
Summary Boxes / Tables		CESSEM##	default	Summary of Pay Item Sheets	planrd	fdotseed2d.dgn	planrd.dwt
Summary Boxes / Tables		SUMQEM##	default	Summary of Quantities Sheets	planrd	fdotseed2d.dgn	fdotmaster.dwt
Traffic Control		TCDSEM##	default	Traffic Control Design	tcdsrd	fdotseed2d.dgn	fdotmaster.dwt
Traffic Control		TCDTEM##	default	Traffic Control Detail Sheet	tcdsrd	fdotseed2d.dgn	fdotmaster.dwt
Traffic Control		TCGNEM##	default	Traffic Control General Note Sheets	planrd	fdotseed2d.dgn	fdotmaster.dwt
Traffic Control		TCPLEM##	default	Traffic Control Plan Sheets	tcdsrd	fdotseed2d.dgn	fdotmaster.dwt
Traffic Control		TCTYEM##	default	Traffic Control Typical Section Sheets	tcdsrd	fdotseed2d.dgn	fdotmaster.dwt
Typical Sections		TYPDEM##	default	Typical Data Sheet	typdrd	fdotseed2d.dgn	fdotmaster.dwt
Typical Sections		TYPSEM##	default	Typical Section Sheets & Details	open	fdotseed2d.dgn	planrd.dwt
Utilities		UTADEM##	default	Utility Adjustment Sheets	utadr	fdotseed2d.dgn	utadr.dwt
Utilities		UTEXEM##	default	Utilities - Existing	utexrd	fdotseed2d.dgn	survey.dwt
Utilities	X	UTPREM##	default	Utilities - Proposed	utprrd	fdotseed2d.dgn	utprrd.dwt
Verified Utilities		SBVHEM##	default	Summary of Verified Utilities (2D)	planrd	fdotseed2d.dgn	fdotmaster.dwt
Verified Utilities		UTVHEM##	default	Survey of Verified Utilities (2D)	utexrd	fdotseed2d.dgn	survey.dwt



## 4.15 SURVEY STANDARDS

This chapter describes the minimum CADD requirements for Survey CADD operations.

### 4.15.1 Level/Layer and Symbology Standards

Symbology Standards that apply to the Department's Projects are set up under a listing of Standard Level Names with specific ByLevel Color, Style and Weight attributes. These levels are grouped under specific Standard Rules which are associated to each valid Standard Filename of each Discipline for the purpose of performing the Quality Control check for the Department's Standards compliancy of each Project design file. Appendix A provides a listing of all Department CADD Standard Rules with associated Levels and Symbology.

### 4.15.2 Standard File Names

The Department utilizes standard naming conventions and provides automated tools that depend on this naming convention being met. The naming convention confers data information to the downstream customer.

➤ **Standard design file names should follow this format: AAAABB##.ext**

Where **AAAA** = *abbreviated file description*, **BB** = *Discipline Denotation*, **##** = *Sequence number*.

The following table defines the Survey file names with each file including sequential numbering. Standard model names are also provided, however, it is not mandatory to use more than the default model.

**Note** See Section 4.8 of this document for more information about Standard File Names. See Appendix A for the complete listing of level/symbology standards for each applicable CADD Standard Rule.

File Type	Critical	File Name	Model Name	File Description	Standard Rule	MicroStation Seed File	Civil 3D Template File
Drainage	X	DREXRD##	default	Drainage Structures - Existing	drexrd	fdotseed2d.dgn	fdotmaster.dwt
Existing DTM		GDTMRD##	default	Digital Terrain Model / TIN Model - 3D	gdtmrd	fdotseed3d.dgn	survey.dwt
Existing Topography	X	TOPORD##	default	Topography - Existing	topord	fdotseed2d.dgn	survey.dwt
Existing Topography		TREERD##	default	Tree Survey Sheet	topord	fdotseed2d.dgn	survey.dwt
Existing Utilities	X	UTEXRD##	default	Utilities - Existing	utexrd	fdotseed2d.dgn	survey.dwt
Project Network Control		CTLSRD##	default	Survey Project Network Control Sheets	planrd	fdotseed2d.dgn	ctlsrd.dwt
Survey Development	See note below	SURVRD##	default	Survey Development Model for 3D Design	survrd	fdotseed3d.dgn	survey.dwt
Verified Utilities	X	UTVHRD##	default	Survey of Verified Utilities (3D version of UTEXRD.dgn)	utexrd	fdotseed3d.dgn	survey.dwt

**Note** The SURVRD file is a critical file for MicroStation SS4 Corridor Modeling (3D) projects only.

### 4.15.3 Data Files Created by Survey

Additional geometry input files are also created for delivery to design. For example: files of existing points, profiles, survey chains, alignments, surfaces, etcetera, should be created in LandXML 1.2 format. For information about LandXML see: <http://www.LandXML.org>. All data delivered to the Department should be placed under the \survey\ discipline folder, which the Department's standard folder structure is included for this purpose. Additional sub-folders may be created under the \survey\ discipline folder to segregate and further organize data. For example: the case where a CAiCE project is placed within the project folder structure under the \survey\ discipline folder for delivery.

**Note** See Section 4.7 for requirements for creating additional sub-folders.

### 4.15.4 Resource Files

CAiCE and GEOPAK use a feature table to look-up appropriate element symbology for given objects, defined by their "feature" found in the survey. AutoCAD Civil 3D uses similar technology.

For CAiCE, the feature table is found in the folder named x:\FDOTSS4\CAiCE\FTB\, where "x" is the workstation drive letter.

The CAiCE feature table correlates the level numbers (200+ through 9xxx) used in CAiCE to the level names corresponding to the MicroStation DGN file, the SMD features used by GEOPAK Survey and the layer names in the description key/figure prefix database used by AutoCAD Civil 3D. This table is placed in the \CAiCE\FTB\ folder.

A corresponding feature table with an .ftm extension is also loaded to the x:\FDOTSS4\CAiCE\FTB\ folder to control symbology on alignment chains (Geometry Chains with stationing). This table is used by the **Settings > Object Display > Geometry Chains** command in CAiCE to control the proper symbology of alignment stationing, station tics, and station labels based upon scale.

**Note** The name of the .ftm feature table must match the name of the active .ftb feature table in use during a CAiCE session.

#### ➤ CAiCE Tables and Cell Libraries

CAiCE feature tables and cell libraries are provided for existing topography, utilities and drainage features. The tables and cell libraries included for Roadway Design are:

- **FDOT\_SS4.FTB** - Feature table containing existing features used by Roadway Design.
- **FDOT\_SS4.FTM** - Corresponding table for controlling alignment / chain symbology and bearing / distance chain labeling (attaches automatically when FDOT\_SS4.FTB is attached).
- **SYENG\_SS4.CCL** - CAiCE format of the cell library used by Roadway Design.
- **SYENG\_SS4.CEL** - MicroStation format of the cell library used by Roadway Design.

#### ➤ Feature List Files

Feature List files; *FDOTTOPO.lis*, *FDOTDran.lis*, and *FDOTUtil.lis*, are also installed into the x:\FDOTSS4\CAiCE\FTB\ folder to assist the user in creating the CAiCE screen graphics containing the appropriate data for producing the three typical design files required by design, *TOPORD00.dgn*, *DREXR00.dgn*, and *UTEXRD00.dgn*. These List files are listings of the feature codes that belong in the respective design files. Consult your CAiCE documentation on the use of List files.

**Note** A Department CAiCE application, Theme Viewer, can accomplish a similar function to using CAiCE list files.

#### ➤ CAiCE Cell Library

MicroStation Cell libraries cannot be used or attached by CAiCE directly. The MicroStation cell library is translated to CAiCE's own version of a cell library (\*.CCL versus MicroStation \*.CEL).

➤ CAiCE Translation Table

A CAiCE Translation Table, *Edgntype.tbl*, is another resource file provided for CAiCE that maps CAiCE line styles to MicroStation custom line styles. This table is in the CADD Software Install at the x:\FDOTSS4\CAiCE\DGN\ subfolder.

**Note** To have compatibility with MicroStation long name cells and levels, two files, DGNCell.TBL and DGNLevel.tbl, must reside under your \CAiCE\DGN\ folder.

➤ Additional CAiCE Tables and Cell Libraries

Additional CAiCE feature tables and cell libraries are also provided for existing topography files, created for Right-of-Way mapping purposes. Mapping uses additional consolidation of certain monument symbols and has other symbolization requirements. The tables and cell libraries included are:

- **FDOT\_SS4RW.FTB** - Feature table containing the topography features used in ROW Mapping.
- **FDOT\_SS4RW.FTM** - Corresponding table for controlling alignment / chain symbology and bearing / distance chain labeling (attaches automatically when FDOT\_SS4RW.FTB is attached).
- **RWENG\_SS4.CCL** - CAiCE format of the cell library for use in ROW mapping.
- **RWENG\_SS4.CEL** - MicroStation format of the topo cell library for use in ROW mapping.

➤ CAiCE Special Characters

CAiCE does not support True Type Fonts. CAiCE Font(s) 48 & 58 will have to be manually replaced by True Type Fonts in MicroStation if the CDG2V8 Macro is used for importing CAiCE data.

- **CAiCE font 48 and translating to MicroStation** - Font 48 does not use the standard ASCII table for all special characters. In particular, the degree symbol ( ° ) for MicroStation requires that CAiCE place the Caret Symbol ( ^ ) in CAiCE text strings so MicroStation will look correct when data is translated to MicroStation graphics. To force CAiCE to substitute the ( ^ ) for the degree ( ° ), CAiCE needs to be set by selecting the menu options: **Settings > Special Characters** and set the ASCII value of 94 to represent degrees as shown in the figure to the right.

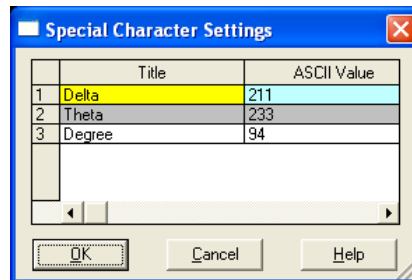

- **Right of Way project font 58 in MicroStation** - If exporting to a Right of Way map, CAiCE needs to be set by selecting the menu items: **Settings > Special Characters** and set the ASCII value 33 to the Delta symbol as shown in the figure to the right.

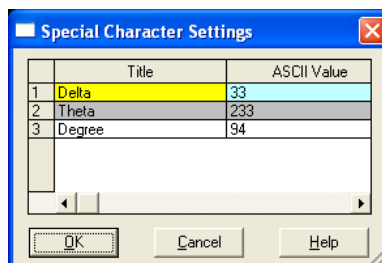

## 4.15.5 GEOPAK Survey and Bentley Survey

The GEOPAK Survey application uses a feature table called *fdot\_ss4.smd*. This feature table is installed into the *x:\FDOTSS4\geopak\databases\* folder by the CADD Software Install routine ('x' is the drive letter where the CADD Software is installed). The *fdot\_ss4.smd* should be used when processing field measurement .OBS files, importing CAiCE KCP files, reading GEOPAK Input files and visualizing features with the Survey Display dialogue box or the COGO Navigator. The *fdot\_ss4rw.smd* feature table is the Right of Way counterpart feature table and should be used when importing or visualizing Right of Way features or products such as the *TOPORW##.dgn* file.

The Bentley Survey application (formerly known as Data Acquisition) uses a XML version of the GEOPAK SMD files named *Survey\_display.xml* and *ROW\_Display.xml*. Both feature files can be found in the *x:\FDOTSS4\geopak\databases\* folder and are imbedded in the *FDOT\_SurveyFeatures\_RD.dgnlib* and *FDOT\_SurveyFeatures\_RW.dgnlib* respectively. It is NOT necessary to attach these feature files when working within the FDOT workspace.

**Note** AutoCAD Civil 3D DESCRIPTION KEYS for translating point objects are found imbedded in the individual templates provided in the Department's Civil 3D State Kit and are not separate resource files. The FIGURE PREFIX DATABASE for translating chains into Civil 3D figures is delivered as part of the Department's State Kit for Civil 3D.

Both GEOPAK and CAiCE use the similar cell libraries for survey graphics. The cell libraries (*syeng.cel* for Roadway design and *rweng.cel* for Right of Way) should be referenced from the *x:\FDOTSS4\RESOURCES\Cell\* folder. (*x:\FDOT2015.C3D\DATA\BLOCKS\ROW.DWG* for AutoCAD)

## 4.15.6 AutoCAD Civil 3D

Standard survey files developed for Autodesk workflows are created by using the FDOT2015.C3D software in conjunction with the Department's standard surveying templates provided by the FDOT2015.C3D software install routine. These standard surveying templates are installed into the *x:\FDOT2015.C3D\Data\Templates\* folder by the FDOT2015.C3D software Install routine ('x' is the drive letter where the FDOT2015.C3D software is installed).

The LandXMLGrouper is also provided by the FDOT2015.C3D software install routine. The LandXMLGrouper routine presorts XML files exported from EFB or CAiCE into point and figure groups that can be used for building standard surveying deliverables similar to the CAiCE theme viewer.

**Note** AutoCAD Civil 3D surveying deliverables must be developed within Civil 3D to be compatible with AutoCAD workflows. Surfaces and Alignments are specific formats within Civil 3D. Point objects and figures (chains) are also specific to Civil 3D. Converting Surveying deliverable MicroStation DGN files to DWG or vice versa will not create an acceptable deliverable in the current workflows for either MicroStation or AutoCAD products.

## 4.15.7 Survey Data

The Department's *Surveying Procedure*, Topic 550-030-101 and the *Surveying Handbook* governs the requirements for survey procedure for the Department's projects. These documents are available at: [http://www.dot.state.fl.us/surveyingandmapping/doc\\_pubs.shtm](http://www.dot.state.fl.us/surveyingandmapping/doc_pubs.shtm)

## 4.15.8 County Mapping

The production of County Maps is an internal function of the Department's Surveying and Mapping Office. This documentation refers to the graphical symbology standards used for the production of those maps. For information regarding file naming conventions and other standards in use during the production of the Department's County maps, contact the Geographic Mapping Office in the Department's Surveying and Mapping Office at (850) 414-4111.

File Type	Description	Color	Line Style	Weight	Cell
All	Adjacent County and State Text				
All	Airport Names				
All	Airport Runways			6	
All	Airports Commercial				cscapt
All	Airports Commercial				cap
All	Airports Landing Strip or Private Airport				cslstp
All	Airports Landing Strip or Private Airport				ldarsp
All	Airports Military				csmfld
All	Airports Military				milffad
All	Backdrop	30			
All	Backdrop	60			
All	Bay				2
All	Bay Text				2
All	Bayou and Harbor, etc.				3
All	Bayou and Harbor, etc. Text				3
All	Boundary Section Lines (hidden)	31			
All	Bridges			0	
All	Bridges			1	
All	Bridges Interstate	1			
All	Bridges and Drawbridges County Highways	4			
All	Bridges and Drawbridges County Highways Text	8			
All	Bridges and Drawbridges Local Roads				
All	Bridges and Drawbridges Local Roads Text	18			
All	Bridges and Drawbridges State Highways	3			
All	Bridges and Drawbridges State Highways Text	7			
All	Bridges and Drawbridges Toll Roads	5			
All	Bridges and Drawbridges Toll Roads Text	5			
All	Bridges and Drawbridges US Highways	2			
All	Bridges and Drawbridges US Highways Text	6			
All	Bridges Interstate Text	4			
All	Cities Incorporated Area			0	
All	Cities Incorporated Linear Boundaries			1	
All	City Streets			1	
All	Coastal Waterway				csicw
All	Coastal Waterway Text				10
All	College or University	71			
All	College or University Text	30			8
All	Communities and Subdivisions Names without Post Office				3
All	Communities Names with Post Office				2
All	Connecting Roads			2	
All	Coordinate ticks Lat Longs				csotic
All	Coordinate ticks State Plane				csstic
All	County Boundary		7	6	
All	County Parks	70			
All	County Parks Text	148			10

File Type	Description	Color	Line Style	Weight	Cell
All	County Roads Related Text				
All	County Route Divided Highway Outline and Fill				
All	County Routes Highway Center Lines			3	
All	County Routes Ramps			2	
All	County Seat				cscose
All	County Seat Names			4	
All	County Seat Names			6	
All	Culture			0	
All	Culture			1	
All	Culture			2	
All	Culture Text				1
All	Cut Border				
All	Extended Township Lines	43	3	2	
All	Forbes Purchase		3	3	
All	Forbes Purchase Section lines		3	0	
All	Forbes Purchase Township and Range Lines		3	2	
All	Geographic Features Text			1	
All	Heliports				csheli
All	Intermittent Ponds				1
All	Intermittent Ponds Text				8
All	Interstate Divided Highway Outline and Fill				
All	Interstate Highway Center Lines			3	
All	Interstate Ramps			2	
All	Interstates Related Text				
All	Islands				
All	Islands Text Coastal (Keys, etc.)			2	
All	Islands Text Inland (Hammocks and Ridges, etc.)				1
All	Lakes and Ponds				
All	Lakes and Ponds Text				9
All	Land Grant Boundaries		4	0	
All	Legend				
All	Local Roads Divided Highway Outline and Fill				
All	Local Roads Improved	11		1	
All	Local Roads Paved	11		2	
All	Local Roads Related Cells				cslgf0
All	Local Roads Related Cells				cslgf1
All	Local Roads Related Cells				cslgf2
All	Local Roads Related Cells				cslgf3
All	Local Roads Related Cells				cslgf4
All	Local Roads Related Cells				csp1
All	Local Roads Related Cells				csp2
All	Local Roads Related Cells				cspnf1
All	Local Roads Related Cells				cspnf2
All	Local Roads Related Cells				cspsf1
All	Local Roads Related Cells				cspsf2
All	Local Roads Related Text				
All	Local Roads Unimproved	10		1	
All	Mangroves				mg
All	Mangroves				csman1
All	Mangroves				smg
All	Map Border				
All	Map Border Text and Cells				
All	Map Information Text and Cells				

File Type	Description	Color	Line Style	Weight	Cell
All	Map Information Text and Cells				
All	Masks for Road Features				
All	Masks for Text				
All	Military Bases	66			
All	Military Bases Text	146			7
All	Narrow Canals		5		
All	Narrow Canals		5		
All	Narrow Canals		5		
All	Narrow Canals Text				7
All	Narrow River Creek and Branch and Slough	12		1	
All	Narrow River Creek and Branch and Slough	12		1	
All	Narrow River Creek and Branch and Slough	12		1	
All	Narrow River Creek and Branch and Slough Text				6
All	National Forest	65			
All	National Forest Text	44			1
All	National Park	69			
All	National Park Text	44			2
All	National Wildlife Refuge and Preserve	75			
All	National Wildlife Refuge and Preserve Text	144			3
All	Ocean and Gulf				1
All	Ocean and Gulf Text				1
All	Other Incorporated Names			2	
All	Other Incorporated Names			3	
All	Other Survey Related Text				3
All	Planning Number Interstates				cssir1
All	Planning Number Interstates				cssir2
All	Planning Number Interstates				cssir3
All	Planning Number US Highways				cssus1
All	Planning Number US Highways				cssus2
All	Planning Number US Highways				cssus3
All	Planning Number US Highways				cssus1
All	Planning Number US Highways				cssus2
All	Planning Number US Highways				cssus3
All	Populations				1
All	Quad Borders				
All	Railroad Stations				csrsta
All	Railroads	3			
All	Railroads Text				
All	Road shields County Roads				cs1crs
All	Road shields County Roads				cs2crs
All	Road shields County Roads				cs3crs
All	Road shields County Roads				cs4crs
All	Road shields Interstates				cs1irs
All	Road shields Interstates				cs2irs
All	Road shields Interstates				cs3irs
All	Road shields State Highways				cs1srs
All	Road shields State Highways				cs2srs
All	Road shields State Highways				cs3srs
All	Road shields Toll roads				cs1trs
All	Road shields Toll roads				cs2trs
All	Road shields Toll roads				cs3trs
All	Road shields Toll roads				cstps
All	Road shields US Highways				cs1urs

File Type	Description	Color	Line Style	Weight	Cell
All	Road shields US Highways				cs2urs
All	Road shields US Highways				cs3urs
All	Road shields US Highways Alternate				cs1usa
All	Road shields US Highways Alternate				cs2usa
All	Road shields US Highways Alternate				cs3usa
All	Road shields US Highways Business				cs1usb
All	Road shields US Highways Business				cs2usb
All	Road shields US Highways Business				cs3usb
All	Seaplane facility				csseap
All	Section Lines		0	0	
All	Section Numbers				1
All	State Boundary		6	6	
All	State Capital				cscptl
All	State Forest	67			
All	State Forest Text	145			4
All	State Park	14			
All	State Park Text	145			5
All	State Prisons	124			
All	State Prisons Text	124			9
All	State Roads Related Text				
All	State Route Divided Highway Outline and Fill				
All	State Routes Highway Center Lines			3	
All	State Routes Ramps			2	
All	State Survey Lines		1	1	
All	State Wildlife Refuge and Preserve	72			
All	State Wildlife Refuge and Preserve	74			
All	State Wildlife Refuge and Preserve Text	147			6
All	Street Related Text				
All	Strip Mining Area	117			
All	Survey by Others		2	1	
All	Survey Correction Text within map				4
All	Swamps				sw3
All	Swamps	15			
All	Swamps Text	45			
All	Toll Divided Highway Outline and Fill				
All	Toll Highway Center Lines			3	
All	Toll Ramps			2	
All	Toll roads Related Text				
All	Town Centers				cscctr
All	Township and Range lines		0	2	
All	Township and Range Tics				csttic
All	Township and Range Text				2
All	Triangulation Station				cstria
All	Triangulation Station				trista
All	Triangulation Station Text	97			2
All	Un-Inventoried Roads and Features				
All	US Highways Related Text				
All	US Route Divided Highway Outline and Fill				
All	US Routes Highway Center Lines			3	
All	US Routes Ramps			2	
All	Wide Rivers and Canals	12		1	4
All	Wide Rivers and Canals Text				5
All	Wildlife Management Area Text	94			11



## 4.16 DRAINAGE STANDARDS

The purpose of this chapter is to provide CADD Standards for the Department’s projects generated by Roadway Design and Drainage Design. (See also Section 4.18 of this Chapter for Roadway Standards)

### 4.16.1 Standard File Names

The Department utilizes standard naming conventions and provides automated tools that depend on this naming convention being met. The naming convention confers data information to the downstream customer.

- **Standard design file names should follow this format: AAAABB##.ext**

Where **AAA** = *abbreviated file description*, **BB** = *Discipline Denotation*, **##** = *Sequence number*.

The following table defines the Drainage File names with each file including sequential numbering. Standard model names are also provided. Since most Drainage files are shared with Roadway, the two groups must coordinate the creation and ownership of these files.

**Note** See Section 4.8 of this document for more information about Standard File Names. See Appendix A for the complete listing of level/symbology standards for each applicable CADD Standard Rule.

File Type	Critical	File Name	Model Name	File Description	Standard Rule	MicroStation Seed File	Civil 3D Template File
Borders & Sheets		BDDMRD##	default	Border Sheet Reference File for Drainage Map Sheet	planrd	fdotseed2d.dgn	
Borders & Sheets		LDPRRD##	default	Lateral Ditch Plan / Profile Sheet	plprrd	fdotseed2d.dgn	fdotmaster.dwt
Cross Sections	X	DRXSRD##	rdxsrd Patrd Xsshrd Rdxsrd_shg	Drainage Structure Cross Sections Drainage Structure Pattern Lines Drainage Structure Shapes Drainage Structure Cross Section Sheets	drxsrd	fdotseedxs.dgn	fdotmaster.dwt
Cross Sections	X	LDXSRD##	Rdxsrd Patrd Xsshrd Rdxsrd_shg	Lateral Ditch XSections, Pattern Line & Shapes Lateral Ditch Pattern Lines Lateral Ditch Shapes Lateral Ditch Cross Section Sheets	rdxsrd	fdotseedxs.dgn	rdxsrd.dwt
Cross Sections	X	PDXSRD##	rdxsrd Patrd Xsshrd Rdxsrd_shg	Pond Cross Sections Pond Pattern Lines Pond Shapes Pond Cross Section Sheets	pdxsrd	fdotseedxs.dgn	fdotmaster.dwt
Drainage		DRDTRD##	default	Drainage Detail Sheet	drdrtd	fdotseed2d.dgn	fdotmaster.dwt
Drainage		DREXRD##	default	Drainage Structures - Existing	drexrd	fdotseed2d.dgn	fdotmaster.dwt
Drainage		DRFLRD##	default	Drainage Flood Data Form	drprrd	fdotseed2d.dgn	fdotmaster.dwt
Drainage		DRMPRD##	default	Drainage Map	drmprd	fdotseed2d.dgn	fdotmaster.dwt
Drainage		DROMRD##	default	Drainage Optional Materials Tabulation	planrd	fdotseed2d.dgn	fdotmaster.dwt
Drainage	X	DRPRRD##	default	Drainage Structures - Proposed	drprrd	fdotseed2d.dgn	fdotmaster.dwt
Proposed Design		PDPLRD##	default	Pond Design	drprrd	fdotseed2d.dgn	fdotmaster.dwt
Proposed Design		SWPPRD##	default	Storm Water Pollution Prevention Plan	plprrd	fdotseed2d.dgn	swpprd.dwt
Proposed Design		TEXTDR##	default	Text Labels & Miscellaneous Descriptions	planrd	fdotseed2d.dgn	
Proposed Design		WETLRD##	default	Wetlands Delineation for Drainage	planrd	fdotseed2d.dgn	fdotmaster.dwt

File Type	Critical	File Name	Model Name	File Description	Standard Rule	MicroStation Seed File	Civil 3D Template File
Summary Boxes /Tables		BRHYRD##	default	Bridge Hydraulics Recommendation Sheet	planrd	fdotseed2d.dgn	fdotmaster.dwt
Summary Boxes /Tables		BXCLRD##	default	Box Culvert Wing wall Design and Special Details	drdtrd	fdotseed2d.dgn	fdotmaster.dwt
Summary Boxes /Tables		SUMDRD##	default	Summary of Drainage Structures	planrd	fdotseed2d.dgn	fdotmaster.dwt

## 4.16.2 File Sharing and Merging

Every project utilizes the standard folder structure regardless of the project requirements. Data for each discipline is maintained in its sub-folder. If a discipline requires information from another discipline, the needed file(s) must be referenced from the original folder, not copied.

## 4.16.3 Resource Files

ECSO provides software resources for Drainage plans preparation using GEOPAK and Civil 3D. Some Districts utilize other Drainage analysis and design applications, such as Automated Storm Sewer Analysis and Design (ASAD). The Drainage databases produced by drainage design applications must be delivered with the project.

## 4.16.4 Engineering Data

The Drainage discipline folder contains the additional sub-folder named `\eng_data\` designated to contain the following:

- Image files of the plan sheets for the drainage design, if applicable
- Quality Control Reports
- Engineering Data output files including Drainage network(s) LandXML as applicable
- Drainage Reports, including drainage databases used for reports
- All supplemental hand calculations (scanned and saved in PDF format)
- Other data pertinent to the overall drainage design

## 4.16.5 Packaging

Listed below are files created by Roadway that are to be treated as Drainage files:

- **DRDTRD##.DGN** - Drainage Detail Sheets
- **DREXRD##.DGN** - Drainage Existing Structures
- **DRFLRD##.DGN** - Flood Data Form
- **DRMPRD##.DGN** - Drainage Map, if required in the PPM) included in the final submittal
- **DRPRRD##.DGN** - Drainage Proposed Structures
- **DRXSRD##.DGN** - Drainage Structure Cross Sections
- **SUMDRD##.DGN** - Summary of Drainage Structures

## 4.17 ROADWAY STANDARDS

CADD Standards for component plans are defined in their respective chapters. See the Department’s PPM Volume 2 for the Sequence of Plans Preparation and the definition of component plans.

### 4.17.1 Standard File Names

The Department utilizes standard naming conventions and provides automated tools that depend on this naming convention being met. The naming convention confers data information to the downstream customer.

➤ **Standard design file names should follow this format: AAAABB##.ext**

Where **AAAA** = *abbreviated file description*, **BB** = *Discipline Denotation*, **##** = *Sequence number*.

The following table defines the Roadway File names with each file including sequential numbering. Standard model names are also provided. Since most Drainage files are shared with Roadway, the two groups must coordinate the creation and ownership of these files.

The file types listed in the following table may be used by other disciplines, and the first four characters of the file name are consistent between disciplines, but the fifth and sixth characters vary to reflect the discipline name. Each discipline chapter details their Standard File Names. Standard Model names are also provided in the table, however, it is not mandatory to use more than the default model, with the exception of those listed in this table.

**Note** See Section 4.8 of this document for more information about Standard File Names. See Appendix A for the complete listing of level/symbology standards for each applicable CADD Standard Rule.

File Type	Critical	File Name	Model Name	File Description	Standard Rule	MicroStation Seed File	Civil 3D Template File
Borders & Sheets		BDBRRD##	default	Border Sheet Reference File for Bridge Hydraulic Sheet	planrd	fdotseed2d.dgn	
Borders & Sheets		BDDMRD##	default	Border Sheet Reference File for Drainage Map Sheet	planrd	fdotseed2d.dgn	
Borders & Sheets		BDPLRD##	default	Border Sheet Reference File for Plan Sheet	planrd	fdotseed2d.dgn	
Borders & Sheets		BDPPRD##	default	Border Sheet Reference File for Plan/Profile Sheet	plprrd	fdotseed2d.dgn	
Borders & Sheets		BDPRRD##	default	Border Sheet Reference File for Profile Sheet	plprrd	fdotseed2d.dgn	
Borders & Sheets		BDXSRD##	rdxsrd	Border Sheet Reference File for Cross-Section Sheet	rdxsrd	fdotseedxs.dgn	
Borders & Sheets		GNNTRD##	default	Project Notes	planrd	fdotseed2d.dgn	fdotmaster.dwt
Borders & Sheets		LDPRRD##	default	Lateral Ditch Plan / Profile Sheet	plprrd	fdotseed2d.dgn	fdotmaster.dwt
Borders & Sheets		PLANRD##	default	Plan Sheet	planrd	fdotseed2d.dgn	fdotmaster.dwt
Borders & Sheets		PLAYRD##	default	Project Layout Sheets	planrd	fdotseed2d.dgn	fdotmaster.dwt
Borders & Sheets		PLPRRD##	default	Plan & Profile Sheets	plprrd	fdotseed2d.dgn	fdotmaster.dwt
Borders & Sheets		PRDSRD##	default	Project Profile Layout	plprrd	fdotseed2d.dgn	fdotmaster.dwt
Borders & Sheets		PROFRD##	default	Profile Sheets	plprrd	fdotseed2d.dgn	fdotmaster.dwt
Borders & Sheets		TMSSRD##	default	Traffic Monitoring Site Plan Sheets	open	fdotseed2d.dgn	fdotmaster.dwt
Clipping		CLIPRD##	default	Clip Borders	cliprd	fdotseed2d.dgn	fdotmaster.dwt
Clipping		MTPLRD##	default	Motif file for plan sheets	planrd	fdotseed2d.dgn	fdotmaster.dwt
Clipping		MTPRRD##	default	Motif file for profile sheets	plprrd	fdotseed2d.dgn	fdotmaster.dwt
Cross Sections		AMGMRD##	default	Automated Machine Guidance Model (3D)	open	fdotseed3d.dgn	fdotmaster.dwt
Cross Sections		GKLNRD##	default	GEOPAK Lines for Existing Features	survrd	fdotseed2d.dgn	
Cross Sections		DRXSRD##	Rdxsrd Pattrd	Drainage Structure XSections,Pattern Lines & Shapes Drainage Structure Pattern Lines	drxsrd	fdotseedxs.dgn	fdotmaster.dwt

File Type	Critical	File Name	Model Name	File Description	Standard Rule	MicroStation Seed File	Civil 3D Template File
			Xsshrd Rdxsrd_shg	Drainage Structure Shapes Drainage Structure Cross Section Sheets			
Cross Sections	X	LDXSRD##	rdxsrd Pattrd Xsshrd Rdxsrd_shg	Lateral Ditch Cross-Sections Lateral Ditch Pattern Lines Lateral Ditch Shapes Lateral Ditch Cross Section Sheets	rdxsrd	fdotseedxs.dgn	rdxsrd.dwt
Cross Sections	X	PDXSRD##	Rdxsrd Pattrd Xsshrd Rdxsrd_shg	Pond XSections,Pattern Lines & Shapes Pond Pattern Lines Pond Shapes Pond Cross Section Sheets	pdxsrd	fdotseedxs.dgn	fdotmaster.dwt
Cross Sections	X	RDXSRD##	rdxsrd Pattrd Xsshrd Rdxsrd_shg	Roadway Cross-Sections Roadway Pattern Lines Roadway Shapes Roadway Cross Section Sheets	rdxsrd	fdotseedxs.dgn	fdotmaster.dwt
Drainage		DRDTRD##	default	Drainage Detail Sheet	drdtrd	fdotseed2d.dgn	fdotmaster.dwt
Drainage		DREXRD##	default	Drainage Structures - Existing	drexrd	fdotseed2d.dgn	fdotmaster.dwt
Drainage		DRFLRD##	default	Drainage Flood Data Form	drprrd	fdotseed2d.dgn	fdotmaster.dwt
Drainage		DRMPRD##	default	Drainage Map	drmprd	fdotseed2d.dgn	fdotmaster.dwt
Drainage		DROMRD##	default	Drainage Optional Materials Tabulation	planrd	fdotseed2d.dgn	fdotmaster.dwt
Drainage	X	DRPRRD##	default	Drainage Structures - Proposed	drprrd	fdotseed2d.dgn	fdotmaster.dwt
Drainage	X	DRXSRD##	rdxsrd	Drainage Structure Cross Sections, Pattern Lines and Shapes	drxsrd	fdotseedxs.dgn	fdotmaster.dwt
Existing DTM		GDTMRD##	default	Digital Terrain Model / TIN Model - 3D	gdtmrd	fdotseed3d.dgn	survey.dwt
Existing Topography		TOPOEM##	default	Topography-Existing (Locations for Environmental Concerns)	topord	fdotseed2d.dgn	survey.dwt
Existing Topography	X	TOPORD##	default	Topography-Existing (Utility & Drainage not included)	topord	fdotseed2d.dgn	survey.dwt
Key Sheets		KEYSRD##	default	Key Sheet	keysht	fdotseedkeymap.dgn	keysht.dwt
Project Network Control		CTLSRD##	default	Survey Project Network Control Sheets	planrd	fdotseed2d.dgn	ctlsrd.dwt
Proposed Design		ALGNRD##	alnrd	Alignment Layout	alnrd	fdotseed2d.dgn	fdotmaster.dwt
Proposed Design		BKSWRD##	default	Back of Sidewalk Profiles	plprrd	fdotseed2d.dgn	fdotmaster.dwt
Proposed Design	X	CORRRD##	default	Corridor Design Model	dsgnrd	fdotseed2d.dgn	fdotmaster.dwt
Proposed Design		CURCRD##	default	Curve or Coordinate Data Sheet	planrd	fdotseed2d.dgn	fdotmaster.dwt
Proposed Design	X	DSGNRD##	default	Proposed Design	dsgnrd	fdotseed2d.dgn	fdotmaster.dwt
Proposed Design		DSPFRD##	default	Proposed Profile	plprrd	fdotseed2d.dgn	fdotmaster.dwt
Proposed Design		INTDRD##	default	Intersection/Interchange Details	planrd	fdotseed2d.dgn	fdotmaster.dwt
Proposed Design		INTPRD##	default	Intersection/Interchange Profiles	plprrd	fdotseed2d.dgn	fdotmaster.dwt
Proposed Design		MITGRD##	default	Mitigation Areas	planrd	fdotseed2d.dgn	fdotmaster.dwt
Proposed Design		PDPLRD##	default	Pond Design	drprrd	fdotseed2d.dgn	fdotmaster.dwt
Proposed Design	X	QTDSRD##	default	Quantity Computation Shapes/Calculations	qtdsrd	fdotseed2d.dgn	fdotmaster.dwt
Proposed Design	X	QUANRD##	default	Quantity Computation Details	qtdsrd	fdotseed2d.dgn	fdotmaster.dwt
Proposed Design	X	RDTMRD##	default	Proposed Digital Terrain Surface Model	dtmrd	fdotseed2d.dgn	fdotmaster.dwt
Proposed Design		RWDTRD##	default	Right of Way Details for Roadway	rwdtrd	fdotseed2d.dgn	rwdtrd.dwt

File Type	Critical	File Name	Model Name	File Description	Standard Rule	MicroStation Seed File	Civil 3D Template File
Proposed Design		SCGRRD##	default	Selective Clearing & Grubbing Sheet	planrd	fdotseed2d.dgn	fdotmaster.dwt
Proposed Design		SIGNCB##	default	Digital Signatures – Core Borings	open	fdotseed2d.dgn	digitalsignature.dwt
Proposed Design		SIGNPC##	default	Digital Signatures - Project Network Control	open	fdotseed2d.dgn	digitalsignature.dwt
Proposed Design		SIGNRD##	default	Digital Signatures	open	fdotseed2d.dgn	digitalsignature.dwt
Proposed Design		SIGNVU##	default	Digital Signatures - Verified Utilities	open	fdotseed2d.dgn	digitalsignature.dwt
Proposed Design		SWPPRD##	default	Storm Water Pollution Prevention Plan	plprrd	fdotseed2d.dgn	swpprd.dwt
Proposed Design		TEXTDR##	default	Text Labels & Miscellaneous Descriptions	planrd	fdotseed2d.dgn	
Proposed Design		TEXTRD##	default	Text Labels & Miscellaneous Descriptions	planrd	fdotseed2d.dgn	
Proposed Design		WETLRD##	default	Wetlands Delineation Sheet	planrd	fdotseed2d.dgn	fdotmaster.dwt
Special Details		CSINRD##	default	Concrete Slab Inventory	planrd	fdotseed2d.dgn	fdotmaster.dwt
Special Details		SPDTRD##	default	Special Details Sheet	open	fdotseed2d.dgn	fdotmaster.dwt
Summary Boxes / Tables		BRHYRD##	default	Bridge Hydraulics Recommendation Sheet	planrd	fdotseed2d.dgn	fdotmaster.dwt
Summary Boxes / Tables		BXCLRD##	default	Box Culvert Wingwall Design & Special Details	drdrtd	fdotseed2d.dgn	fdotmaster.dwt
Summary Boxes / Tables		CESSRD##	default	Summary of Pay Item Sheets	planrd	fdotseed2d.dgn	planrd.dwt
Summary Boxes / Tables		SUMDRD##	default	Summary of Drainage Structures	planrd	fdotseed2d.dgn	fdotmaster.dwt
Summary Boxes / Tables		SUMQRD##	default	Summary of Quantities Sheets	planrd	fdotseed2d.dgn	fdotmaster.dwt
Traffic Control	X	TCDSRD##	default	Traffic Control Design	tcdsrd	fdotseed2d.dgn	fdotmaster.dwt
Traffic Control		TCDTRD##	default	Traffic Control Detail Sheet	tcdsrd	fdotseed2d.dgn	fdotmaster.dwt
Traffic Control		TCGNRD##	default	Traffic Control General Note Sheets	planrd	fdotseed2d.dgn	fdotmaster.dwt
Traffic Control		TCPLRD##	default	Traffic Control Plan Sheets	tcdsrd	fdotseed2d.dgn	fdotmaster.dwt
Traffic Control		TCTYRD##	default	Traffic Control Typical Section Sheets	open	fdotseed2d.dgn	fdotmaster.dwt
Typical Sections		TYPDRD##	default	Typical Data Sheet	typdrd	fdotseed2d.dgn	fdotmaster.dwt
Typical Sections		TYPSRD##	default	Typical Section Sheets & Details	open	fdotseed2d.dgn	planrd.dwt
Utilities		UTADRD##	default	Utility Adjustment Sheets	utadr	fdotseed2d.dgn	utadr.dwt
Utilities	X	UTEXRD##	default	Utilities - Existing	utexrd	fdotseed2d.dgn	survey.dwt
Utilities	X	UTPRRD##	default	Utilities - Proposed	utprrd	fdotseed2d.dgn	utprrd.dwt
Verified Utilities		SBVHRD##	default	Summary of Verified Utilities (2D)	planrd	fdotseed2d.dgn	fdotmaster.dwt
Verified Utilities		UTVHRD##	default	Survey of Verified Utilities (2D)	utexrd	fdotseed2d.dgn	survey.dwt
Verified Utilities		UTVHRD##	default	Survey of Verified Utilities (3D version of utexrd.dgn)	utexrd	fdotseed3d.dgn	survey.dwt

## 4.17.2 Engineering Data

The \roadway\ discipline folder contains the sub-folder named \eng\_data\ designated to store the following:

- Quality Control Reports.
- Engineering Data output files, including LandXML files of the points, alignments, profiles, sections, surfaces, pipe networks and Multiline files.
- Roadway design reports, including any databases used for report generation.
- All supplemental hand design calculations (scanned and saved in PDF format).
- Other data pertinent to the overall roadway design.

## 4.18 SIGNING & PAVEMENT MARKING STANDARDS

Signing and Pavement Marking Plans are usually a component set of plans (see Section 4.17 Roadway Standards). However, if the Signing and Pavement Marking Plans are the lead plan set, then the standards set in Section 4.17 Roadway Standards, pertaining to elements that are specific to the lead plan set, will apply to the Signing and Pavement Marking plan set (i.e., Traffic Control files and elements, preliminary estimate sheets, etcetera).

The Department’s projects requiring minor Signing and Pavement Marking construction work may include these features detailed on sheets in the Roadway Plans. If this is the case, the Signing and Pavement Markings element symbology standards apply. However, an exception to the Standard Rules must be created and documented in the Roadway discipline journal file.

When prepared as component plans, Signing and Pavement Parking plans will be assembled as a separate plan set complete with a key sheet, tabulation of quantities and all other relevant Signing and Pavement Marking sheets. The sheets must be numbered consecutively, with sheet numbers prefixed by the letter “S”.

### 4.18.1 Standard File Names

The Department utilizes standard naming conventions and provides automated tools that depend on this naming convention being met. The naming convention confers data information to the downstream customer.

➤ ***Standard design file names should follow this format: AAAABB##.ext***

Where **AAA** = *abbreviated file description*, **BB** = *Discipline Denotation*, **##** = *Sequence number*.

The following table defines the Signing and Pavement Marking File names with each file including sequential numbering. Standard model names are also provided.

The file types listed in the following table may be used by other disciplines, and the first four characters of the file name is consistent between disciplines, but the fifth and sixth characters vary to reflect the discipline name. Each discipline chapter details their Standard File Names. Standard Model names are also provided in the table, however, it is not mandatory to use more than the default model, with the exception of those listed in this table.

**Note** See Section 4.8 of this document for more information about Standard File Names. See Appendix A for the complete listing of level/symbology standards for each applicable CADD Standard Rule.

File Type	Critical	File Name	Model Name	File Description	Standard Rule	MicroStation Seed File	Civil 3D Template File
Borders & Sheets		BDPLSP##	default	Border for Plan Sheets when sheet is referenced	planrd	fdotseed2d.dgn	
Borders & Sheets		BDXSSP##	rdxsrd	Border for Cross Section Sheet when sheet is referenced	rdxssp	fdotseedxs.dgn	
Borders & Sheets		GNNTSP##	default	General Notes	planrd	fdotseed2d.dgn	fdotmaster.dwt
Borders & Sheets		PLANSP##	default	Plan Sheet	planrd	fdotseed2d.dgn	fdotmaster.dwt
Clipping		CLIPSP##	default	Clip Borders	cliprd	fdotseed2d.dgn	fdotmaster.dwt
Clipping		MTPLSP##	default	Motif file for plan sheets	planrd	fdotseed2d.dgn	fdotmaster.dwt
Clipping		MTPRSP##	default	Motif file for profile sheets	plprrd	fdotseed2d.dgn	fdotmaster.dwt
Cross Sections	X	RDXSSP##	rdxsrd	Cross-Sections	rdxssp	fdotseedxs.dgn	fdotmaster.dwt
Existing Topography		TOPOSP##	default	Topography - Existing	topord	fdotseed2d.dgn	survey.dwt
Key Sheets		KEYSSP##	default	Key Sheet	keysht	fdotseedkeymap.dgn	keysht.dwt
Proposed Design		AUTOSP##	default	AutoTurn Turning Radius Data	autosp	fdotseed2d.dgn	fdotmaster.dwt
Proposed Design	X	DSGNP##	default	Proposed Design	dsgnsp	fdotseed2d.dgn	fdotmaster.dwt
Proposed Design		SAPMSP##	default	Layout as a Typical Design or Passing Zone	dsgnsp	fdotseed2d.dgn	fdotmaster.dwt
Proposed Design		SIGNSP##	default	Digital Signatures	open	fdotseed2d.dgn	digitalsignature.dwt

File Type	Critical	File Name	Model Name	File Description	Standard Rule	MicroStation Seed File	Civil 3D Template File
Proposed Design		TEXTSP##	default	Text Labels & Miscellaneous Descriptions	planrd	fdotseed2d.dgn	
Special Details		GSKWSP##	default	Guide Sign Work Sheet & Details	gswksp	fdotseed2d.dgn	fdotmaster.dwt
Special Details		MSARSP##	default	Mast Arm Detail for Signing	msarsp	fdotseed2d.dgn	fdotmaster.dwt
Special Details		SPDTSP##	default	Special Details - Miscellaneous	open	fdotseed2d.dgn	fdotmaster.dwt
Special Details		SPSGSP##	default	Special Sign Details for Overhead	open	fdotseed2d.dgn	fdotmaster.dwt
Summary Boxes /Tables		CESSP##	default	Summary of Pay Item Sheets	planrd	fdotseed2d.dgn	planrd.dwt
Summary Boxes /Tables		TABQSP##	default	Tabulation of Quantity Sheets	planrd	fdotseed2d.dgn	fdotmaster.dwt

### 4.18.2 Sign Design

The Draw Sign program is a MicroStation application that draws sign panels and posts and determines the corresponding pay item of the assembly based on the wind load and post properties. The Draw Sign program requires use of the GEOPAK and GEOPAK Design and Computation (D&C) Manager database (*FDOTxxx.ddb*) to provide automated pay item association. (XXX reflects the current version of database.)

The Department’s Signs application (FDOT Signs) included in the State Kit for Civil 3D, provides similar functionality. It requires the project's pay item database (payitemdb.xml), also used by Entity Manager, to provide automated pay item associations.

### 4.18.3 GuidSIGN

GuidSIGN is the standard sign design software used by the Department. However, using GuidSIGN is not required and other sign design programs available in the industry may be used. The Department’s Level/Symbology Standards must still be met regardless of the software used.

GuidSIGN is a tool to create sign panels. Sign panel design and creation require two (2) separate files: *GSKWSP##.dgn (DWG)* for sign panel design and the worksheet and the *DSGNSP##.dgn (DWG)* file for sign panel placement on the project. There is no limit in the number of sign panels that can be placed in a file.

In addition to the GuidSIGN worksheet design file, required for all non-standard sign designs by the PPM, a DXF output file of the sign for use by a sign cutting shop must be delivered for the creation of the physical sign panel.

### 4.18.4 AutoTURN

AutoTURN is the standard turn radius design software used by the Department. However, using AutoTURN is not required. Other vehicle wheel path design software available in the industry may be used for designing the turning movements of roadway intersections. The Department also uses Autodesk Vehicle Tracking. The Department’s Level/Symbology Standards must still be met regardless of the software used.

## 4.19 SIGNALS STANDARDS

Signalization Plans are usually a component set of plans (see Section 4.17 Roadway Standards). However, if the Signalization Plans are the lead plan set, then the standards set in Section 4.17 Roadway Standards, pertaining to elements that are specific to the lead plan set will apply to the Signalization plan set (i.e., Traffic Control files and elements, preliminary estimate sheets, etcetera)

The Department’s projects requiring minor signalization construction work may include these features detailed on sheets in the Roadway Plans. If this is the case, the Signalization element Level/Symbology Standards within this Section will still apply. However, an exception to the Standard Rules must be created and documented in the Roadway discipline journal file.

When prepared as component plans, Signalization Plans will be assembled as a separate plan set complete with a key sheet, tabulation of quantities and all other relevant signalization sheets. The sheets must be numbered consecutively, with sheet numbers prefixed by the letter “T”. The Signalization Plans show the construction details, signal phasing and other relevant data.

### 4.19.1 Standard File Names

The Department utilizes standard naming conventions and provides automated tools that depend on this naming convention being met. The naming convention confers data information to the downstream customer.

➤ ***Standard design file names should follow this format: AAAABB##.ext***

Where **AAAA** = *abbreviated file description*, **BB** = *Discipline Denotation*, **##** = *Sequence number*.

The following table defines the Signalization File names with each file including sequential numbering. Standard model names are also provided.

The file types listed in the following table may be used by other disciplines, and the first four characters of the file name are consistent between disciplines, but the fifth and sixth characters vary to reflect the discipline name. Each discipline chapter details their Standard File Names. Standard Model names are also provided in the table, however, it is not mandatory to use more than the default model, with the exception of those listed in this table.

**Note** See Section 4.8 of this document for more information about Standard File Names. See Appendix A for the complete listing of level/symbology standards for each applicable CADD Standard Rule.

File Type	Critical	File Name	Model Name	File Description	Standard Rule	MicroStation Seed File	Civil 3D Template File
Borders & Sheets		BDPLSG##	default	Border Sheet Reference File for Plan Sheets	planrd	fdotseed2d.dgn	
Borders & Sheets		GNNTSG##	default	General Notes Sheet	planrd	fdotseed2d.dgn	fdotmaster.dwt
Borders & Sheets		PLANS##	default	Plan Sheet	dsgnsg	fdotseed2d.dgn	fdotmaster.dwt
Clipping		CLIPSG##	default	Clip Borders	cliprd	fdotseed2d.dgn	fdotmaster.dwt
Clipping		MTPLSG##	default	Motif file for plan sheets	planrd	fdotseed2d.dgn	fdotmaster.dwt
Clipping		MTPRSG##	default	Motif file for profile sheets	plprrd	fdotseed2d.dgn	fdotmaster.dwt
Existing Topography		TOPOSG##	default	Topography - Existing	topord	fdotseed2d.dgn	survey.dwt
Key Sheets		KEYSSG##	default	Key Sheet	keysht	fdotseedkeymap.dgn	keysht.dwt
Proposed Design	X	DSGNSG##	default	Proposed Design & Signal information	dsgnsg	fdotseed2d.dgn	fdotmaster.dwt
Proposed Design		SIGNSG##	default	Digital Signatures	open	fdotseed2d.dgn	digitalsignature.dwt
Proposed Design		TEXTSG##	default	Text Labels & Miscellaneous Descriptions	planrd	fdotseed2d.dgn	
Special Details		GSWKSG##	default	Guide Sign Work Sheet & Details	gswksp	fdotseed2d.dgn	fdotmaster.dwt
Special Details		SSDTSG##	default	Special Details for Signs & Miscellaneous Items	dsgnsg	fdotseed2d.dgn	fdotmaster.dwt



File Type	Critical	File Name	Model Name	File Description	Standard Rule	MicroStation Seed File	Civil 3D Template File
Special Details		VHLPSG##	default	Special Loop Details & Instructions	dsgnsg	fdotseed2d.dgn	fdotmaster.dwt
Summary Boxes / Tables		CESSSG##	default	Summary of Pay Items	planrd	fdotseed2d.dgn	planrd.dwt
Summary Boxes / Tables		MSSSG##	default	Mast Arm Detail & Tables	dsgnsg	fdotseed2d.dgn	fdotmaster.dwt
Summary Boxes / Tables		PLDTSG##	default	Pole Tabulation & Details for All Types	dsgnsg	fdotseed2d.dgn	fdotmaster.dwt
Summary Boxes / Tables		TABQSG##	default	Tabulation of Quantity Sheets	planrd	fdotseed2d.dgn	fdotmaster.dwt

## 4.20 HIGHWAY LIGHTING STANDARDS

Highway Lighting Plans are usually a component set of plans (see Section 4.17 Roadway Standards). However, if the Highway Lighting Plans are the lead plan set, then the standards set in Section 4.17, Roadway Standards, pertaining to elements that are specific to the lead plan set will apply to the Highway Lighting plan set (i.e., Traffic Control files and elements, preliminary estimate sheets, etcetera).

When prepared as component plans, Highway Lighting Plans will be assembled as a separate plan set complete with a key sheet, tabulation of quantities and all other relevant lighting sheets. The sheets must be numbered consecutively, with sheet numbers prefixed by the letter “L”.

### 4.20.1 Standard File Names

The Department utilizes standard naming conventions and provides automated tools that depend on this naming convention being met. The naming convention confers data information to the downstream customer.

- ***Standard design file names should follow this format: AAAABB##.ext***

Where **AAA** = *abbreviated file description*, **BB** = *Discipline Denotation*, **##** = *Sequence number*.

The following table defines the Highway Lighting File names with each file including sequential numbering. Standard model names are also provided.

The file types listed in the following table may be used by other disciplines, and the first four characters of the file name are consistent between disciplines, but the fifth and sixth characters vary to reflect the discipline name. Each discipline chapter details their Standard File Names. Standard Model names are also provided in the table, however, it is not mandatory to use more than the default model, with the exception of those listed in this table.

**Note** See Section 4.8 of this document for more information about Standard File Names. See Appendix A for the complete listing of level/symbology standards for each applicable CADD Standard Rule.

File Type	Critical	File Name	Model Name	File Description	Standard Rule	MicroStation Seed File	Civil 3D Template File
Borders & Sheets		BDPLLT##	default	Border Sheet Plan	planrd	fdotseed2d.dgn	
Borders & Sheets		GNNTLT##	default	General Notes	planrd	fdotseed2d.dgn	fdotmaster.dwt
Borders & Sheets		PLANLT##	default	Plan Sheet	planrd	fdotseed2d.dgn	fdotmaster.dwt
Clipping		CLIPTLT##	default	Clip Borders	cliprd	fdotseed2d.dgn	fdotmaster.dwt
Clipping		MTPLLT##	default	Motif file for plan sheets	planrd	fdotseed2d.dgn	fdotmaster.dwt
Clipping		MTPRLT##	default	Motif file for profile sheets	plprrd	fdotseed2d.dgn	fdotmaster.dwt
Existing Topography		TOPOLT##	default	Topography - Existing	topord	fdotseed2d.dgn	survey.dwt

File Type	Critical	File Name	Model Name	File Description	Standard Rule	MicroStation Seed File	Civil 3D Template File
Key Sheets		KEYSLT##	default	Key Sheet	keysht	fdotseedkeymap.dgn	keysht.dwt
Proposed Design	X	DSGNLT##	default	Proposed Design	dsgnlt	fdotseed2d.dgn	fdotmaster.dwt
Proposed Design		SIGNLT##	default	Digital Signatures	open	fdotseed2d.dgn	digitalsignature.dwt
Proposed Design		TEXTLT##	default	Text Labels & Miscellaneous Descriptions	planrd	fdotseed2d.dgn	
Special Details		CNPLLT##	default	Special Pole Detail Sheets (All Types)	dsgnlt	fdotseed2d.dgn	fdotmaster.dwt
Special Details		JCDTLT##	default	Jacking Detail Sheet	open	fdotseed2d.dgn	fdotmaster.dwt
Special Details		LUDTLT##	default	Luminaire & Foundation Detail Sheet (All Types)	dsgnlt	fdotseed2d.dgn	fdotmaster.dwt
Special Details		SRPTLT##	default	Service Point Detail Sheets	open	fdotseed2d.dgn	fdotmaster.dwt
Summary Boxes / Tables		CESSLT##	default	Summary of Pay Item Sheets	planrd	fdotseed2d.dgn	planrd.dwt
Summary Boxes / Tables		PLDTLT##	default	Pole Data Sheets	open	fdotseed2d.dgn	fdotmaster.dwt
Summary Boxes / Tables		TABQLT##	default	Tabulation of Quantity Sheets	planrd	fdotseed2d.dgn	fdotmaster.dwt

## 4.20.2 AGI32 Lighting Software

AGI32 Lighting Software is the standard Lighting Design software used by the Department. However, using AGI32 is not required. Other Lighting design software available in the industry may be used for the Lighting Design. If AGI32 is not used, the Department's Level/Symbology Standards must still be met to be compliant with CADD Standard Rules and Digital Delivery.

## 4.21 LANDSCAPE STANDARDS

Landscape means any vegetation, mulches, irrigation systems and any site amenities, such as, street furniture, decorative paving, fences and lighting (excluding public utility streets and area lighting). Landscape plans may be a component set of plans (see Section 4.17 Roadway Standards), or be prepared independently.

The Department's Projects with minor Landscaping may include landscaping features on separate sheets in the Roadway Plans set or landscaping features may be detailed on the Roadway plans sheets.

When prepared as component plans, Landscape Plans will be assembled as a separate plan set complete with a key sheet, tabulation of quantities and all other relevant Landscape sheets. The sheets must be numbered consecutively with the sheet numbers prefixed by the letters "LD".

A complete set of Landscape plans may include the following:

1. Key Sheet
2. Tabulation of Quantities
3. Planting Sheets
4. Irrigation Layout
5. Details Sheet
6. Other relevant plan sheets as required Pay Items Notes, General Notes or Maintenance Notes and Schedules.

These sub-components should be listed on the Landscape Plans Key Sheet under the "Components of Contract Plan Sets" heading.

## 4.21.1 Standard File Names

The Department utilizes standard naming conventions and provides automated tools that depend on this naming convention being met. The naming convention confers data information to the downstream customer.

➤ ***Standard design file names should follow this format: AAAABB##.ext***

Where **AAA** = *abbreviated file description*, **BB** = *Discipline Denotation*, **##** = *Sequence number*.

The following table defines the Landscaping File names with each file including sequential numbering. Standard model names are also provided.

The file types listed in the following table may be used by other disciplines, and the first four characters of the file name are consistent between disciplines, but the fifth and sixth characters vary to reflect the discipline name. Each discipline chapter details their Standard File Names. Standard Model names are also provided in the table, however, it is not mandatory to use more than the default model, with the exception of those listed in this table.

**Note** See Section 4.8 of this document for more information about Standard File Names. See Appendix A for the complete listing of level/symbology standards for each applicable CADD Standard Rule.

File Type	Critical	File Name	Model Name	File Description	Standard Rule	MicroStation Seed File	Civil 3D Template File
Borders & Sheets		BDPLD##	default	Border Referencing for Sheet Plan	planrd	fdotseed2d.dgn	
Borders & Sheets		GNNLTD##	default	General Notes	planrd	fdotseed2d.dgn	fdotmaster.dwt
Borders & Sheets		PLANLD##	default	Plan Sheet	planrd	fdotseed2d.dgn	fdotmaster.dwt
Borders & Sheets		PLAYLD##	default	Project Layout Sheet	planrd	fdotseed2d.dgn	fdotmaster.dwt
Clipping		CLIPLD##	default	Clip Borders	cliprd	fdotseed2d.dgn	fdotmaster.dwt
Clipping		MTPLD##	default	Motif file for plan sheets	planrd	fdotseed2d.dgn	fdotmaster.dwt
Clipping		MTPRLD##	default	Motif file for profile sheets	plprrd	fdotseed2d.dgn	fdotmaster.dwt
Existing Topography		TOPLD##	default	Topography - Existing	topord	fdotseed2d.dgn	survey.dwt
Key Sheets		KEYSLD##	default	Key Sheet	keysht	fdotseedkeymap.dgn	keysht.dwt
Proposed Design	X	DSGNLD##	default	Proposed Landscape (Planting) Design	dsgnld	fdotseed2d.dgn	fdotmaster.dwt
Proposed Design		HSDTLD##	default	Hardscape details	planrd	fdotseed2d.dgn	fdotmaster.dwt
Proposed Design		IRRGLD##	default	Proposed Irrigation Design	irrgld	fdotseed2d.dgn	fdotmaster.dwt
Proposed Design		SIGNLD##	default	Digital Signatures	open	fdotseed2d.dgn	digitalsignature.dwt
Proposed Design		TMOTLD##	default	Technical Maintenance Plan	dsgnld	fdotseed2d.dgn	fdotmaster.dwt
Special Details		DETLD##	default	Details	open	fdotseed2d.dgn	fdotmaster.dwt
Special Details		GRDTLD##	default	Proposed Grading	planrd	fdotseed2d.dgn	fdotmaster.dwt
Summary Boxes / Tables		CESSLD##	default	Summary of Pay Items	planrd	fdotseed2d.dgn	planrd.dwt
Summary Boxes / Tables		TABQLD##	default	Tabulation of Quantity Sheets	planrd	fdotseed2d.dgn	fdotmaster.dwt

**Note** Hardscape Design files must use the same symbology standards as the Landscape Design file.

## 4.22 STRUCTURES STANDARDS

The use and generation of CADD files by Structures in regards to the Department’s Projects must be in accordance with the general standards for all disciplines, unless superseded by instructions contained within this section.

The following table defines the resource files and features used for the FDOT Structures Workspace.

Feature	Bentley	Autodesk
Color Table	Color.tbl	<i>Not Applicable</i>
Font Files	FDOT*.ttf	FDOT*.ttf
Level Definitions	Strslevels.dgnlib	StructuresTemplateDetail.dwt StructuresTemplatePlan.dwt
Main Cell/Block Library	TTF_V8Structures.cel	Structures.dwg
Models Allowed	Yes	<i>Not Applicable</i>
QC Rule	Spst10	Spst10
Seed/Template Files	StructuresSeed.dgn StructuresSeed3d.dgn	StructuresTemplateDetail.dwt StructuresTemplatePlan.dwt
Text / Dimension Styles Definitions	Strslevels.dgnlib	StructuresTemplateDetail.dwt StructuresTemplatePlan.dwt

### 4.22.1 Standard File Names

The Department utilizes standard naming conventions for all of its CADD files and provides automated tools that depend on this naming convention. The naming convention confers data and information to the downstream customer.

➤ **Standard file names for Bridges should follow this format: B#AAA...##.[ext]**

Where: **B#** = Bridge Plans Sequence Number, **AAA...** = Abbreviated File Description, **##** = Sequence Number.

*For Example:* First EndBent sheet of Bridge 1 in a plan set would be named *B1EndBent01.dgn*

Files created by Structures remain in the \struct\ discipline folder, the sheet numbers must be prefixed with the target discipline’s sheet prefixes.

<http://www.dot.state.fl.us/structures/StructuresManual/CurrentRelease/StructuresManual.shtm>

The Department delivers the **Create File/Project** applications within the CADD Software Suite to ensure files are named to Department CADD Standards.

Files containing Data Table cells (previously semi-standards) should be named *B#DataTable##.dgn* and should be placed in the plans with the corresponding component detail sheet. Files marked as Geotech are listed to show the order of placement within the Structures plans component only. All Geotech files should be located in the \Geotech\ discipline folder and should follow Geotechnical Standards listed in Section 4.24.

Existing Bridge plan sheets must be submitted in PDF format, not DGN, and manually inserted into the plans using sheet numbers as provided in the following table.

The table below defines the Department’s Structures standard file names; each must include sequence numbering. Sheet Order is the default, but is modifiable to suit project specific requirements.

**Note** See Section 4.8 of this document for more information about Standard File Names. See Appendix A for the complete listing of level/symbology standards for each applicable CADD Standard Rule. See **Structures Detailing Manual** Volume 2, Chapter 3 for complete details on sheet numbering instructions.

<b>Structures Plans Naming Convention and Numbering Convention</b>					
<b>Sheet Order</b>	<b>File Name</b>	<b>Suggested Sheet Title</b>	<b>Sheet Prefix</b>	<b>Drawing Prefix *</b>	<b>As-Built Plans System - Structure Type</b>
<i>* - Optional    ** - Lead or Component Key Sheet    ## - Sheet Sequence Number</i>					
1	B#KeySheet.dgn	Bridge Key Sheet **	B-##	*	Key Sheet
2	B#Index.dgn	Index of Sheets	B-##	*	Gen. Notes, Index of Bridge Sheets, Pay Item Notes
3	B#TRANSPORTStructures.dgn	Summary of Pay Items Sheet (For Structures only projects)	B-##, ...	*	Gen. Notes, Index of Bridge Sheets, Pay Item Notes
4	B#SumOfQuantities.dgn	Summary of Structures Quantities	B#-##	*	(See Section 4.22.1)
5	B#GeneralNotes.dgn	General Notes	B#-##	*	Gen. Notes, Index of Bridge Sheets, Pay Item Notes
6	B#PlanElev.dgn	Plan and Elevation	B1-##,B2-##, ...	*	Plan and Elevation
7	B#VertCurveSuperEL.dgn	Profile Grade & Superelevation Transition	B1-##,B2-##, ...	*	Plan and Elevation
8	B#BridgeHydro.dgn	Bridge Hydraulic Recommendations	B1-##,B2-##, ...	*	Bridge Hydraulic Recommendation Sheet
9	B#ConstNotes.dgn	Construction Notes	B1-##,B2-##, ...	*	Miscellaneous Details
10	B#ConstDet.dgn	Construction Details	B1-##,B2-##, ...	*	Miscellaneous Details
11	B#ConstSeq.dgn	Construction Sequence	B1-##,B2-##, ...	*	Miscellaneous Details
12	B#RemoveExist.dgn	Removal of Existing Structures	B1-##,B2-##, ...	*	Miscellaneous Details
13	B#BridgeSection.dgn	Section Through Bridge	B1-##,B2-##, ...	*	Miscellaneous Details
14	B#FoundLay.dgn	Foundation Layout	B1-##,B2-##, ...	*	Foundation Layout
15	B#PileData.dgn	Pile Data Table	B1-##,B2-##, ...	*	Foundation Layout
16	B#PileDet.dgn	Pile Details	B1-##,B2-##, ...	*	Foundation Layout
17	B#DrillShaft.dgn	Drilled Shaft Data Table	B1-##,B2-##, ...	*	Foundation Layout
18	B#DrillShaftDeT.dgn	Drilled Shaft Details	B1-##,B2-##, ...	*	Intermediate Bents or Piers
19	B#Footing.dgn	Footing	B1-##,B2-##, ...	*	Intermediate Bents or Piers
20	B#FootingDet.dgn	Footing Details	B1-##,B2-##, ...	*	Intermediate Bents or Piers
21	B#EndBent.dgn	End Bent	B1-##,B2-##, ...	*	End Bents Details
22	B#EndBentDet.dgn	End Bent Details	B1-##,B2-##, ...	*	End Bents Details
23	B#IntBent.dgn	Intermediate Bent	B1-##,B2-##, ...	*	Intermediate Bents or Piers
24	B#IntBentDet.dgn	Intermediate Bent Details	B1-##,B2-##, ...	*	Intermediate Bents or Piers
25	B#Pier.dgn	Pier	B1-##,B2-##, ...	*	Intermediate Bents or Piers
26	B#PierDet.dgn	Pier Details	B1-##,B2-##, ...	*	Intermediate Bents or Piers
27	B#BeamLay.dgn	Beam Layout	B1-##,B2-##, ...	*	Superstructure Sheets
28	B#BeamLayAASHTO.dgn	AASHTO Beam Layout	B1-##,B2-##, ...	*	Superstructure Sheets
29	B#BeamLayBulbT.dgn	Bulb-T Beam Layout	B1-##,B2-##, ...	*	Superstructure Sheets

<b>Structures Plans Naming Convention and Numbering Convention</b>					
<b>Sheet Order</b>	<b>File Name</b>	<b>Suggested Sheet Title</b>	<b>Sheet Prefix</b>	<b>Drawing Prefix *</b>	<b>As-Built Plans System - Structure Type</b>
30	B#BeamLayFub.dgn	Florida U-Beam Layout	B1-##,B2-##, ...	*	Superstructure Sheets
31	B#BeamLayInvT.dgn	Inverted T Beam Layout	B1-##,B2-##, ...	*	Superstructure Sheets
32	B#BeamLayT.dgn	T Beam Layout	B1-##,B2-##, ...	*	Superstructure Sheets
33	B#PrestSlab.dgn	Prestressed Slab Units	B1-##,B2-##, ...	*	Superstructure Sheets
34	B#TypicalSection.dgn	Typical Section Through Bridge Deck	B1-##,B2-##, ...	*	Superstructure Sheets
35	B#FinishGrEL.dgn	Finish Grade Elevations	B1-##,B2-##, ...	*	Superstructure Sheets
36	B#Camber.dgn	Camber Diagrams	B1-##,B2-##, ...	*	Superstructure Sheets
37	B#FramingPlan.dgn	Framing Plan	B1-##,B2-##, ...	*	Superstructure Sheets
38	B#Superst.dgn	Superstructure	B1-##,B2-##, ...	*	Superstructure Sheets
39	B#SuperstDet.dgn	Superstructure Details	B1-##,B2-##, ...	*	Superstructure Sheets
40	B#ClosureJoint.dgn	Closure Joint Details	B1-##,B2-##, ...	*	Beam Sheets
41	B#CrossFrameDet.dgn	Cross Frame Details	B1-##,B2-##, ...	*	Beam Sheets
42	B#DiaphragmDet.dgn	Diaphragm Details	B1-##,B2-##, ...	*	Beam Sheets
43	B#ErectSeq.dgn	Erection Sequence	B1-##,B2-##, ...	*	Beam Sheets
44	B#ErectProced.dgn	Erection Procedure for Launching Girder	B1-##,B2-##, ...	*	Beam Sheets
45	B#FieldSplice.dgn	Bolted Field Splice	B1-##,B2-##, ...	*	Beam Sheets
46	B#FieldSpliceDet.dgn	Bolted Field Splice Details	B1-##,B2-##, ...	*	Beam Sheets
47	B#FloorBeam.dgn	Floor Beams	B1-##,B2-##, ...	*	Beam Sheets
48	B#SteelGirder.dgn	Steel Girder	B1-##,B2-##, ...	*	Beam Sheets
49	B#SteelDet.dgn	Steel Girder Details	B1-##,B2-##, ...	*	Beam Sheets
50	B#Stiffener.dgn	Stiffener Details	B1-##,B2-##, ...	*	Beam Sheets
51	B#BearingDet.dgn	Bearing Details	B1-##,B2-##, ...	*	Superstructure Sheets
52	B#PierPTDet.dgn	Precast Pier Post-Tensioning Details	B1-##,B2-##, ...	*	Superstructure Sheets
53	B#SegDimCap.dgn	Pier Cap Segment Dimensions	B1-##,B2-##, ...	*	Superstructure Sheets
54	B#TransPTPier.dgn	Pier Transverse Post-Tensioning	B1-##,B2-##, ...	*	Superstructure Sheets
55	B#SegLayout.dgn	Segment Layout	B1-##,B2-##, ...	*	Superstructure Sheets
56	B#JointCoord.dgn	Segment Joint Coordinates	B1-##,B2-##, ...	*	Superstructure Sheets
57	B#SegDimBox.dgn	Segment Dimensions	B1-##,B2-##, ...	*	Superstructure Sheets
58	B#ReinfSeg.dgn	Segment Reinforcing	B1-##,B2-##, ...	*	Superstructure Sheets
59	B#SegDimDev.dgn	Deviation Segment Dimensions	B1-##,B2-##, ...	*	Superstructure Sheets
60	B#ReinfDevSeg.dgn	Deviation Segment Reinforcing	B1-##,B2-##, ...	*	Superstructure Sheets
61	B#SegDimPier.dgn	Pier Segment Dimensions	B1-##,B2-##, ...	*	Superstructure Sheets
62	B#ReinfPierSeg.dgn	Pier Segment Reinforcing	B1-##,B2-##, ...	*	Superstructure Sheets
63	B#SegDimAbut.dgn	Abutment Segment Dimensions	B1-##,B2-##, ...	*	Superstructure Sheets
64	B#ReinfAbutSeg.dgn	Abutment Segment Reinforcing	B1-##,B2-##, ...	*	Superstructure Sheets
65	B#ReinfClosureSeg.dgn	Closure Segment Reinforcing	B1-##,B2-##, ...	*	Superstructure Sheets
66	B#BulkheadSeg.dgn	Bulkhead Segment Details	B1-##, B2-##, ...	*	Superstructure Sheets
67	B#LongPT.dgn	Longitudinal Post-Tensioning Layout	B1-##,B2-##, ...	*	Superstructure Sheets

<b>Structures Plans Naming Convention and Numbering Convention</b>					
<b>Sheet Order</b>	<b>File Name</b>	<b>Suggested Sheet Title</b>	<b>Sheet Prefix</b>	<b>Drawing Prefix *</b>	<b>As-Built Plans System - Structure Type</b>
68	B#ContinuityTend.dgn	Continuity Tendon Layout	B1-##,B2-##, ...	*	Superstructure Sheets
69	B#FuturePTLay.dgn	Future Post-Tensioning Layout	B1-##,B2-##, ...	*	Superstructure Sheets
70	B#PTDet.dgn	Post-Tensioning Details	B1-##,B2-##, ...	*	Superstructure Sheets
71	B#PTQuantities.dgn	Post-Tensioning Quantities	B1-##,B2-##, ...	*	Superstructure Sheets
72	B#TendonCurveDet.dgn	Tendon Curvature Details	B1-##,B2-##, ...	*	Superstructure Sheets
73	B#TransPTAbut.dgn	Abutment Segment Transverse Post-Tensioning	B1-##,B2-##, ...	*	Superstructure Sheets
74	B#TransTendonDet.dgn	Transverse Post-Tensioning Details	B1-##,B2-##, ...	*	Superstructure Sheets
75	B#SegConstSeq.dgn	Construction Sequence (PT)	B1-##,B2-##, ...	*	Superstructure Sheets
76	B#BearingPads.dgn	Neoprene Bearing Pads	B1-##,B2-##, ...	*	Superstructure Sheets
77	B#BearingPlates.dgn	Beveled Bearing Plates	B1-##,B2-##, ...	*	Superstructure Sheets
78	B#PotBearing.dgn	Pot Bearing Details	B1-##,B2-##, ...	*	Superstructure Sheets
79	B#JackingDet.dgn	Jacking Details	B1-##,B2-##, ...	*	Superstructure Sheets
80	B#ExpJointDet.dgn	Expansion Joint Details	B1-##,B2-##, ...	*	Superstructure Sheets
81	B#SlidingPlate.dgn	Traffic / Pedestrian Railing Sliding Plate Assembly	B1-##,B2-##, ...	*	Superstructure Sheets
82	B#ApproachSlab.dgn	Approach Slab	B1-##,B2-##, ...	*	Miscellaneous Details
83	B#ConduitDet.dgn	Utility Conduit Details	B1-##,B2-##, ...	*	Miscellaneous Details
84	B#JunctionBox.dgn	Junction Box	B1-##,B2-##, ...	*	Miscellaneous Details
85	B#DrainDet.dgn	Drain Details	B1-##,B2-##, ...	*	Miscellaneous Details
86	B#LadderDet.dgn	Ladder Details	B1-##,B2-##, ...	*	Miscellaneous Details
87	B#MiscDet.dgn	Miscellaneous Details	B1-##,B2-##, ...	*	Miscellaneous Details
88	B#SidewalkDet.dgn	Sidewalk Details	B1-##,B2-##, ...	*	Miscellaneous Details
89	B#SurfaceFinish.dgn	Surface Finish Details	B1-##,B2-##, ...	*	Miscellaneous Details
90	B#FenderSystem.dgn	Fender System	B1-##,B2-##, ...	*	Miscellaneous Details
91	B#FenderDet.dgn	Fender Details	B1-##,B2-##, ...	*	Miscellaneous Details
92	B#RiprapRubble.dgn	Rubble Riprap	B1-##,B2-##, ...	*	Miscellaneous Details
93	B#SlopeProtectionConcrete.dgn	Concrete Slope Protection	B1-##,B2-##, ...	*	Miscellaneous Details
94	B#ScourPlan.dgn	Plan View of Scour Protection	B1-##,B2-##, ...	SP-##	Miscellaneous Details
95	B#BotContourMap.dgn	Bottom Contour Map	B1-##,B2-##, ...	SP-##	Miscellaneous Details
96	B#ScourProf.dgn	Profile of Scour Protection	B1-##,B2-##, ...	SP-##	Miscellaneous Details
97	B#ScourDetail.dgn	Scour Protection Details	B1-##,B2-##, ...	SP-##	Miscellaneous Details
98	B#RiprapSand.dgn	Sand Cement Riprap	B1-##,B2-##, ...	SP-##	Miscellaneous Details
99	B#MiscStrTempBridge.dgn	Temporary Bridge Details	B1-##,B2-##, ...	*	Miscellaneous Details
100	B#AccessOpen.dgn	Access Opening	B1-##,B2-##, ...	*	Miscellaneous Details
101	B#MaintLight.dgn	Maintenance Lighting Plan	B1-##,B2-##, ...	*	Miscellaneous Details
102	B#MaintLightDet.dgn	Maintenance Lighting Details	B1-##,B2-##, ...	*	Miscellaneous Details
103	B#Handrail.dgn	Handrail	B1-##,B2-##, ...	*	Miscellaneous Details
104	B#CompTestSetup.dgn	Compression Test Setup	B1-##,B2-##, ...	LT-##	Miscellaneous Details
105	B#DrillShaftLT123.dgn	Drilled Shaft Load Test Sites 1,2&3	B1-##,B2-##, ...	LT-##	Miscellaneous Details

<b>Structures Plans Naming Convention and Numbering Convention</b>					
<b>Sheet Order</b>	<b>File Name</b>	<b>Suggested Sheet Title</b>	<b>Sheet Prefix</b>	<b>Drawing Prefix *</b>	<b>As-Built Plans System - Structure Type</b>
106	B#LTSumDrillShaft.dgn	Drilled Shaft Load Test Program Summary	B1-##,B2-##, ...	LT-##	Miscellaneous Details
107	B#InstruDet.dgn	Instrumentation Details	B1-##,B2-##, ...	LT-##	Miscellaneous Details
108	B#LateralLT.dgn	Lateral Load Test Details	B1-##,B2-##, ...	LT-##	Miscellaneous Details
109	B#LTFrame.dgn	Load Test Frame Configuration	B1-##,B2-##, ...	LT-##	Miscellaneous Details
110	B#LTBraceDet.dgn	Load Test Reaction Girder Bracing Details	B1-##,B2-##, ...	LT-##	Miscellaneous Details
111	B#LTGirderDet.dgn	Load Test Reaction Girder Details	B1-##,B2-##, ...	LT-##	Miscellaneous Details
112	B#OsterbergCell.dgn	Osterberg Cell 3000 ton Load Testing Device	B1-##,B2-##, ...	LT-##	Miscellaneous Details
113	B#LTSumPile.dgn	Pile Load Test Program Summary	B1-##,B2-##, ...	LT-##	Miscellaneous Details
114	B#PlatformDet.dgn	Service Platform Deck and Frame Details	B1-##,B2-##, ...	LT-##	Miscellaneous Details
115	B#StatnamicLT.dgn	Statnamic Load Test Details	B1-##,B2-##, ...	LT-##	Miscellaneous Details
116	B#RebarList.dgn	Reinforcing Bar List	B1-##,B2-##, ...		Reinforcing Bar List
117	B#BP-Notes.dgn	Bascule Pier Notes	B1-##,B2-##, ...	BP-##	Movable Bridge - Structural
118	B#BP-Plan.dgn	Bascule Pier Plan	B1-##,B2-##, ...	BP-##	Movable Bridge - Structural
119	B#BP-Elevations.dgn	Bascule Pier Elevations	B1-##,B2-##, ...	BP-##	Movable Bridge - Structural
120	B#BP-Sections.dgn	Bascule Pier Sections	B1-##,B2-##, ...	BP-##	Movable Bridge - Structural
121	B#BP-StlFraming.dgn	Bascule Pier Steel Framing	B1-##,B2-##, ...	BP-##	Movable Bridge - Structural
122	B#BP-Details.dgn	Bascule Pier Details	B1-##,B2-##, ...	BP-##	Movable Bridge - Structural
123	B#BP-Misc.dgn	Bascule Pier Miscellaneous	B1-##,B2-##, ...	BP-##	Movable Bridge - Structural
124	B#BP-Quantities.dgn	Bascule Pier Quantities	B1-##,B2-##, ...	BP-##	Movable Bridge - Structural
125	B#BP-Reinforcing.dgn	Bascule Pier Reinforcing	B1-##,B2-##, ...	BP-##	Movable Bridge - Structural
126	B#BP-Barlist.dgn	Bascule Pier Bar Lists	B1-##,B2-##, ...	BP-##	Movable Bridge - Structural
127	B#RP-Notes.dgn	Rest Pier Notes	B1-##,B2-##, ...	RP-##	Movable Bridge - Structural
128	B#RP-Plan.dgn	Rest Pier Plan	B1-##,B2-##, ...	RP-##	Movable Bridge - Structural
129	B#RP-Elevations.dgn	Rest Pier Elevations	B1-##,B2-##, ...	RP-##	Movable Bridge - Structural
130	B#RP-Sections.dgn	Rest Pier Sections	B1-##,B2-##, ...	RP-##	Movable Bridge - Structural
131	B#RP-StlFraming.dgn	Rest Pier Steel Framing	B1-##,B2-##, ...	RP-##	Movable Bridge - Structural
132	B#RP-Details.dgn	Rest Pier Details	B1-##,B2-##, ...	RP-##	Movable Bridge - Structural
133	B#RP-Misc.dgn	Rest Pier Miscellaneous	B1-##,B2-##, ...	RP-##	Movable Bridge - Structural
134	B#RP-Quantities.dgn	Rest Pier Quantities	B1-##,B2-##, ...	RP-##	Movable Bridge - Structural
135	B#RP-Reinforcing.dgn	Rest Pier Reinforcing	B1-##,B2-##, ...	RP-##	Movable Bridge - Structural
136	B#RP-Barlist.dgn	Rest Pier Bar Lists	B1-##,B2-##, ...	RP-##	Movable Bridge - Structural
137	B#BL-Notes.dgn	Bascule Leaf Notes	B1-##,B2-##, ...	BL-##	Movable Bridge - Structural
138	B#BL-SpanLockDet.dgn	Bascule Leaf Span Lock Details	B1-##,B2-##, ...	BL-##	Movable Bridge - Structural
139	B#BL-SpanLockPlan.dgn	Bascule Leaf Span Lock Plan	B1-##,B2-##, ...	BL-##	Movable Bridge - Structural
140	B#BL-Sections.dgn	Bascule Leaf Sections	B1-##,B2-##, ...	BL-##	Movable Bridge - Structural
141	B#BL-ClearDiagram.dgn	Bascule Leaf Clearance Diagram	B1-##,B2-##, ...	BL-##	Movable Bridge - Structural
142	B#BL-ForceDiagram.dgn	Bascule Leaf Force Diagram	B1-##,B2-##, ...	BL-##	Movable Bridge - Structural
143	B#BL-FramePlan.dgn	Bascule Leaf Framing Plan	B1-##,B2-##, ...	BL-##	Movable Bridge - Structural



<b>Structures Plans Naming Convention and Numbering Convention</b>					
<b>Sheet Order</b>	<b>File Name</b>	<b>Suggested Sheet Title</b>	<b>Sheet Prefix</b>	<b>Drawing Prefix *</b>	<b>As-Built Plans System - Structure Type</b>
144	B#BL-Girders.dgn	Bascule Leaf Main Girders	B1-##,B2-##, ...	BL-##	Movable Bridge - Structural
145	B#BL-FloorBeams.dgn	Bascule Leaf Floor Beams	B1-##,B2-##, ...	BL-##	Movable Bridge - Structural
146	B#BL-Strings.dgn	Bascule Leaf Stringers	B1-##,B2-##, ...	BL-##	Movable Bridge - Structural
147	B#BL-Bracing.dgn	Bascule Leaf Bracing	B1-##,B2-##, ...	BL-##	Movable Bridge - Structural
148	B#BL-CantBracket.dgn	Bascule Leaf Cantilever Bracket	B1-##,B2-##, ...	BL-##	Movable Bridge - Structural
149	B#BL-TrunGirder.dgn	Bascule Leaf Trunnion Girder	B1-##,B2-##, ...	BL-##	Movable Bridge - Structural
150	B#BL-CounterWeight.dgn	Bascule Leaf Counter Weight	B1-##,B2-##, ...	BL-##	Movable Bridge - Structural
151	B#BL-CntrWghtGirder.dgn	Bascule Leaf Counter Weight Girder	B1-##,B2-##, ...	BL-##	Movable Bridge - Structural
152	B#BL-Deck.dgn	Bascule Leaf Deck	B1-##,B2-##, ...	BL-##	Movable Bridge - Structural
153	B#BL-Details.dgn	Bascule Leaf Misc. Details	B1-##,B2-##, ...	BL-##	Movable Bridge - Structural
154	B#BL-JointAssembly.dgn	Bascule Leaf Joint Assemblies	B1-##,B2-##, ...	BL-##	Movable Bridge - Structural
155	B#BL-SideWalk.dgn	Bascule Leaf Sidewalk	B1-##,B2-##, ...	BL-##	Movable Bridge - Structural
156	B#BL-TraffRail.dgn	Bascule Leaf Traffic Railing	B1-##,B2-##, ...	BL-##	Movable Bridge - Structural
157	B#BL-PedRail.dgn	Bascule Leaf Pedestrian Railing	B1-##,B2-##, ...	BL-##	Movable Bridge - Structural
158	B#BL-AccPlatforms.dgn	Bascule Leaf Access Platforms	B1-##,B2-##, ...	BL-##	Movable Bridge - Structural
159	B#MechNotes.dgn	Mechanical Notes	B1-##,B2-##, ...	BM-##	Movable Bridge - Mechanical
160	B#MechPlan.dgn	Mechanical Plan	B1-##,B2-##, ...	BM-##	Movable Bridge - Mechanical
161	B#MechElev.dgn	Mechanical Elevation	B1-##,B2-##, ...	BM-##	Movable Bridge - Mechanical
162	B#MechDet.dgn	Mechanical Details	B1-##,B2-##, ...	BM-##	Movable Bridge - Mechanical
163	B#MechSect.dgn	Mechanical Sections	B1-##,B2-##, ...	BM-##	Movable Bridge - Mechanical
164	B#MiscMechDet.dgn	Miscellaneous Mechanical Details	B1-##,B2-##, ...	BM-##	Movable Bridge - Mechanical
165	B#PinionDet.dgn	Pinion Details	B1-##,B2-##, ...	BM-##	Movable Bridge - Mechanical
166	B#TrunAssem.dgn	Trunnion Assembly	B1-##,B2-##, ...	BM-##	Movable Bridge - Mechanical
167	B#TrunDet.dgn	Trunnion Details	B1-##,B2-##, ...	BM-##	Movable Bridge - Mechanical
168	B#DriveAssem.dgn	Drive Assembly	B1-##,B2-##, ...	BM-##	Movable Bridge - Mechanical
169	B#GateAssem.dgn	Gate Assembly	B1-##,B2-##, ...	BM-##	Movable Bridge - Mechanical
170	B#HydraNote.dgn	Hydraulic Notes	B1-##,B2-##, ...	BM-##	Movable Bridge - Mechanical
171	B#HydraCylDet.dgn	Hydraulic Cylinder Details	B1-##,B2-##, ...	BM-##	Movable Bridge - Mechanical
172	B#HydraSchem.dgn	Hydraulic Schematic	B1-##,B2-##, ...	BM-##	Movable Bridge - Mechanical
173	B#ElecNotes.dgn	Electric Notes	B1-##,B2-##, ...	BE-##	Movable Bridge - Electrical
174	B#CCTVDet.dgn	CCTV Details	B1-##,B2-##, ...	BE-##	Movable Bridge - Electrical
175	B#CommLayout.dgn	Communications Layout	B1-##,B2-##, ...	BE-##	Movable Bridge - Electrical
176	B#ConduitRiser.dgn	Conduit Riser	B1-##,B2-##, ...	BE-##	Movable Bridge - Electrical
177	B#ControlDesk.dgn	Control Desk	B1-##,B2-##, ...	BE-##	Movable Bridge - Electrical
178	B#DriveDiag.dgn	Drive Diagram	B1-##,B2-##, ...	BE-##	Movable Bridge - Electrical
179	B#ElecFloorplan.dgn	Electrical Floor Plan	B1-##,B2-##, ...	BE-##	Movable Bridge - Electrical
180	B#GeneratorDet.dgn	Generator Details	B1-##,B2-##, ...	BE-##	Movable Bridge - Electrical
181	B#Grounding.dgn	Grounding and Lighting Protection	B1-##,B2-##, ...	BE-##	Movable Bridge - Electrical

<b>Structures Plans Naming Convention and Numbering Convention</b>					
<b>Sheet Order</b>	<b>File Name</b>	<b>Suggested Sheet Title</b>	<b>Sheet Prefix</b>	<b>Drawing Prefix *</b>	<b>As-Built Plans System - Structure Type</b>
182	B#IOpoints.dgn	Input Output Points, PLC	B1-##,B2-##, ...	BE-##	Movable Bridge - Electrical
183	B#LadderLogic.dgn	Ladder Logic, PLC	B1-##,B2-##, ...	BE-##	Movable Bridge - Electrical
184	B#OpSeq.dgn	Operating Sequence Flowchart	B1-##,B2-##, ...	BE-##	Movable Bridge - Electrical
185	B#PanelBoardSch.dgn	Panel Board Schedule	B1-##,B2-##, ...	BE-##	Movable Bridge - Electrical
186	B#SingleLine.dgn	Single Line Diagram	B1-##,B2-##, ...	BE-##	Movable Bridge - Electrical
187	B#SubCableDet.dgn	Submarine Cable Details	B1-##,B2-##, ...	BE-##	Movable Bridge - Electrical
188	B#SurgeSup.dgn	Surge Suppression Details	B1-##,B2-##, ...	BE-##	Movable Bridge - Electrical
189	B#ElecMachLayout.dgn	Electrical Machinery Layout	B1-##,B2-##, ...	BE-##	Movable Bridge - Electrical
190	B#MiscElecDet.dgn	Miscellaneous Electrical Details	B1-##,B2-##, ...	BE-##	Movable Bridge - Electrical
191	B#Legend.dgn	Symbol Legend	B1-##,B2-##, ...	BE-##	Movable Bridge - Electrical
192	B#MCC.dgn	Motor Control Center	B1-##,B2-##, ...	BE-##	Movable Bridge - Electrical
193	B#ThreeLineDiag.dgn	Three Line Diagram	B1-##,B2-##, ...	BE-##	Movable Bridge - Electrical
194	B#TrafCtrlDet.dgn	Traffic Control Details	B1-##,B2-##, ...	BE-##	Movable Bridge - Electrical
195	B#NaviLightDet.dgn	Navigation Lighting System Details	B1-##,B2-##, ...	BE-##	Miscellaneous Details
196	B#TowerDet.dgn	Control Tower Details	B1-##,B2-##, ...	BT-##	Miscellaneous Details
197	B#TowerLighting.dgn	Control Tower Lighting	B1-##,B2-##, ...	BT-##	Miscellaneous Details
198	B#TowerLayout.dgn	Tower, Lighting and Pier Layout	B1-##,B2-##, ...	BT-##	Miscellaneous Details
199	B#Plumbing.dgn	Plumbing	B1-##,B2-##, ...	BT-##	Miscellaneous Details
200	B#WorkID.dgn	Work Identification Sheet	B1-##,B2-##, ...	BT-##	Miscellaneous Details
201	B#SitePlan.dgn	Site Plan for Rest Area	B1-##,B2-##, ...	BT-##	Miscellaneous Details
202	B#CatwalkDet.dgn	Catwalk Details	B1-##,B2-##, ...	BT-##	Miscellaneous Details
203	B#PedBridgeDataTable##.dgn	Pedestrian Bridge Data	BP-##	*	Pedestrian Bridge Sheets
204	B#WallControl.dgn	Wall Control Drawing	BW-##	W1-##,W2-##, ...	Retaining Wall Sheets
205	B#Bulkhead.dgn	Bulkhead	BW-##	W1-##,W2-##, ...	Retaining Wall Sheets
206	B#BulkheadDet.dgn	Bulkhead Details	BW-##	W1-##,W2-##, ...	Retaining Wall Sheets
207	B#CrashWall.dgn	Crash Wall	BW-##	W1-##,W2-##, ...	Retaining Wall Sheets
208	B#SheetPileWallAnch.dgn	Anchored Sheet Pile Wall	BW-##	W1-##,W2-##, ...	Retaining Wall Sheets
209	B#SheetPileWallCant.dgn	Cantilever Sheet Pile Wall	BW-##	W1-##,W2-##, ...	Retaining Wall Sheets
210	B#MSEwall.dgn	MSE Wall	BW-##	W1-##,W2-##, ...	Retaining Wall Sheets
211	B#RetainingWall.dgn	Retaining Wall	BW-##	W1-##,W2-##, ...	Retaining Wall Sheets
212	B#SheetPileWall.dgn	Sheet Pile Retaining Wall	BW-##	W1-##,W2-##, ...	Retaining Wall Sheets
213	B#SheetPileWallST.dgn	Steel Sheet Pile Retaining Wall	BW-##	W1-##,W2-##, ...	Retaining Wall Sheets
214	B#SheetPileWallConc.dgn	Concrete Sheet Pile Retaining Wall	BW-## / none	W1-##,W2-##, ...	Retaining Wall Sheets
215	B#NoiseWall.dgn	Noise Wall	BW#-## / none	SB1-##, SB2-##, ...	
	WallControl.dgn	Wall Control Drawing (Non-Bridge Related)	BW-##	W1-##,W2-##, ...	Retaining Wall Sheets
	Bulkhead.dgn	Bulkhead (Non-Bridge Related)	BW-##	W1-##,W2-##, ...	Retaining Wall Sheets
	BulkheadDet.dgn	Bulkhead Details (Non-Bridge Related)	BW-##	W1-##,W2-##, ...	Retaining Wall Sheets
	CrashWall.dgn	Crash Wall (Non-Bridge Related)	BW-##	W1-##,W2-##, ...	Retaining Wall Sheets

Structures Plans Naming Convention and Numbering Convention					
Sheet Order	File Name	Suggested Sheet Title	Sheet Prefix	Drawing Prefix *	As-Built Plans System - Structure Type
	SheetPileWallAnch.dgn	Anchored Sheet Pile Wall <i>(Non-Bridge Related)</i>	BW-##	W1-##,W2-##, ...	Retaining Wall Sheets
	SheetPileWallCant.dgn	Cantilever Sheet Pile Wall <i>(Non-Bridge Related)</i>	BW-##	W1-##,W2-##, ...	Retaining Wall Sheets
	MSEwall.dgn	MSE Wall (Non-Bridge Related)	BW-##	W1-##,W2-##, ...	Retaining Wall Sheets
	RetainingWall.dgn	Retaining Wall (Non-Bridge Related)	BW-##	W1-##,W2-##, ...	Retaining Wall Sheets
	SheetPileWall.dgn	Sheet Pile Retaining Wall <i>(Non-Bridge Related)</i>	BW-##	W1-##,W2-##, ...	Retaining Wall Sheets
	SheetPileWallST.dgn	Steel Sheet Pile Retaining Wall <i>(Non-Bridge Related)</i>	BW-##	W1-##,W2-##, ...	Retaining Wall Sheets
	SheetPileWallConc.dgn	Concrete Sheet Pile Retaining Wall <i>(Non-Bridge Related)</i>	BW-## / none	W1-##,W2-##, ...	Retaining Wall Sheets
	NoiseWall.dgn	Noise Wall (Non-Bridge Related)	BW-## / none	SB1-##, SB2-##, ...	
216	B#MiscStr.dgn B#MiscStrClvt.dgn B#MiscStrHighMast.dgn B#MiscStrMastarm.dgn B#MiscStrOHSign.dgn	Varies Culvert High Mast Light Poles Mastarms Overhead Sign Structures	B#-## / none		
217	B#DataTableLoadRating.dgn	Load Rating Charts	B1-##,B2-##, ...	*	Load Rating Charts
Varies	B#DataTable##.dgn	(Design Standards) Data Tables	B#-##	*	(Varies – See Section 4.22.1)
	B#Preliminary.dgn	Preliminary Plan and Elevation			
	StrBorder.dgn	Referencing Structures Borders			
	MiscStr.dgn	Varies			
	MiscStrClvt.dgn	Culvert			
	MiscStrMastarm.dgn	Mastarms			
	MiscStrHighMast.dgn	High Mast Light Poles			
	MiscStrOHSign.dgn	Overhead Sign Structures			
	SIGNST.dgn	Digital Signatures			

## 4.22.2 Resource Files

Files created for the Structures discipline must use the resource files included with the Department’s CADD Software packages. All files created for Structures Plans sheets must be created from the supplied Structures Seed or Template files. The Structures Seed/Template files for the FDOT Structures Workspace differs from other Seed files in both working units and unit labeling.

The *StrLevels.dgnlib* library file contains the definitions for Levels, Text, & Dimension styles in MicroStation.

The *StructuresTemplateDetail.dwt* and *StructuresTemplatePlan.dwt* template files contain the definitions Levels, Text, & Dimension Styles in AutoCAD.

**Note** For V8 format MicroStation files, working units DO NOT define design plane size, only the method of measurement. Therefore, the design plane is the same size for all seed files.

### 4.22.3 Engineering Data

Engineering Data to be delivered with each project must be located in the `\eng_data` folder and include:

- ASCII files containing Q/C reports
- All computer input and output files used in the design (in native file formats for the software used and printed to PDF format)
- All supplemental design hand design calculations (scanned and saved in PDF or TIFF file formats)

Under the project `\struct` folder, create separate sub-folders for each bridge and/or structure in the project. Name these sub-folders using the sheet prefix and bridge numbers (when applicable) and locate the MicroStation design files for each bridge under these sub-folders. (e.g...`\struct\B`); `\struct\B1-#####`)

Under each bridge and/or structure sub-folder, create an `\eng_data` sub-folder for the Engineering Data related to the design of the project. (e.g...`\struct\B\eng_data`; `\struct\B1-#####\eng_data`). Computer input and output files include files used for all aspects of bridge, retaining wall, and/or miscellaneous structures design. These include, but are not limited to, files generated from the following computer programs:

- |                            |                 |
|----------------------------|-----------------|
| • FDOT Structural Software | • FBPIer        |
| • GTStrudl                 | • LEAP Software |
| • STADD                    | • BD2           |
| • RISA                     | • MDX           |
| • Mathcad Spreadsheets     | • BC            |
| • Excel Spreadsheets       | • Adapt         |

Under each of the `\eng_data` sub-folders for each bridge and/or structure in the project, create subfolders for the applicable programs with two sub-folders: `\PDF` and `\Native`. Place the appropriate input and output files in each sub-folder. Only sign and seal these PDF files when required by Contract.

**Note** For quantity calculations see Section 4.7.2.1.

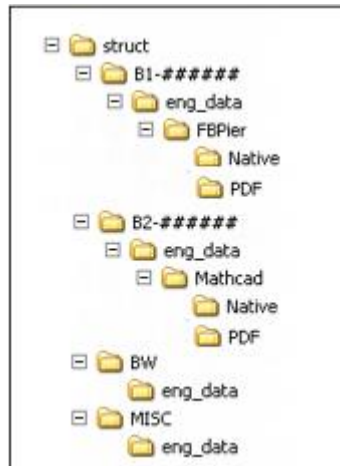

### 4.22.4 Level and Symbology Standards

For the MicroStation FDOT Structures Workspace, element Level/Symbology Standards are defined in the `StrLevels.dgnlib` Structures Level Library and must be selected from the MicroStation level picker. Each level contains a defined color, line weight, line style, and print property. Color must remain set to BYLEVEL (**except where indicated with \*\* in the table below**), line weight & line style may be modified as needed.

For AutoCAD, FDOT Structures object Layer Property Standards are defined in the *StructuresTemplateDetail.dwt* and *StructuresTemplatePlan.dwt* template files and must be selected from the AutoCAD layer selector. Each layer contains a defined color, line weight, linetype, and print property. Color must remain set to ByLayer (*except where indicated with \*\* in the table below*), line weight & line style may be modified as needed. User created Levels ARE NOT acceptable. If additional Levels/Layers are needed, contact the Structures Design Office. The Level named “Default” (in MicroStation) or Layer 0 (in AutoCAD) is not QC compliant and is not to be used for drawing elements. If a discrepancy occurs, the *StrLevels.dgnlib* Structures Level Library or StructuresTemplate file supersedes the symbology table on the following pages.

## 4.22.5 Borders and Scales

### 4.22.5.1 Borders:

Draw all elements at "Full Size" completely before placing text or dimensions. Sheets that reside in the Structures Component of the plan set must use the Structures Border cell “Sheet-Border”. Sheets requiring Structures design that reside within other discipline components of the plan set (Roadway, Lighting, etcetera) must use the Border Roadway w/Initials cell “Sheet-Rdwy”.

Show the scale of the drawing and related details inside the display area of the file, but outside of the Sheet Border area. This is helpful to all users who work on the file.

### 4.22.5.2 Scales:

The following chart is intended to aid the user in determining the appropriate scale for placing the border and text on a drawing based on the actual size of the drawing. Calculations are based on a 9.60" x 15.40" drawing area inside the border.

#### ➤ Architect's Scales

Drawing Scale	Active Scale (AS)	Height (FT.)	Width (FT.)
1/16" = 1'	192	153.59	246.39
3/32" = 1'	128	102.40	164.26
1/8" = 1'	96	76.80	123.20
3/16" = 1'	64	51.20	82.13
1/4" = 1'	48	38.40	61.60
3/8" = 1'	32	25.60	41.07
1/2" = 1'	24	19.20	30.80
3/4" = 1'	16	12.80	20.53
1" = 1'	12	9.60	15.40
1 1/2" = 1'	8	6.40	10.27
3" = 1'	4	3.20	5.13
6" = 1'	2	1.60	2.57
1 = 1	1	.80	1.28

#### ➤ FORMULAS: Architect's Scale:

**AS** = 12 / Drawing Scale (Ex. 1/4" = .25in., then 12/.25 = 48, Therefore AS = 48)

**W** = Sheet Width (in.) / Drawing Scale (Ex. 1/4" = .25in., then 15.36/.25 = 61.44, Therefore W = 61.44)

**H** = Sheet Height (in.) / Drawing Scale (Ex. 1/4" = .25in., then 9.72/.25 = 38.88, Therefore H = 38.88)

➤ **Engineer's Scales**

Drawing Scale	Active Scale (AS)	Height (FT.)	Width (FT.)
1" = 500'	6000	4799.81	7699.69
1" = 400'	4800	3839.85	6159.75
1" = 300'	3600	2879.88	4619.82
1" = 250'	3000	2399.90	3849.85
1" = 200'	2400	1919.92	3079.88
1" = 150'	1800	1439.94	2309.91
1" = 120'	1440	1161.95	1847.93
1" = 100'	1200	959.96	1539.94
1" = 80'	960	767.97	1231.95
1" = 60'	720	575.98	923.96
1" = 50'	600	479.98	769.97
1" = 40'	480	383.98	615.98
1" = 30'	360	287.99	461.98
1" = 20'	240	191.99	307.99
1" = 15'	180	143.99	230.99
1" = 10'	120	96.00	153.99

➤ **FORMULAS: Engineer's Scale:**

**AS** = 12 x Drawing Scale *(Ex. 1"=500', then 12 x 500 = 6000, Therefore AS = 6000)*

**W** = Sheet Width (in.) x Drawing Scale *(Ex. 1"=500', then 15.36 x 500 = 7680, Therefore W = 7680)*

**H** = Sheet Height (in.) x Drawing Scale *(Ex. 1"=500', then 9.72 x 500 = 4860, Therefore H = 4860)*

## 4.22.6 Text Sizes and Weights

The standard annotation text size for structures drawings is .0063' on a printed sheet. Standard text sizes are provided as custom text styles delivered either via the StrsLevels.dgnlib (MicroStation) or Structures Template (AutoCAD) files.

TITLE	FONT	SIZE (Ft)
Revisions	FDOT	.0050
Initials	FDOT	.0058
Annotation/Table Data	FDOT	.0063
View/Sheet/Sect Titles	FDOTBold	.0080
Large	FDOTBold	.0084
Larger	FDOTBold	.0100

The automatic Annotation Scaling service provided by both CADD platforms should be used for all annotations were possible. The Structures Design Office (SDO) uses special, custom fonts in its drawings and CADD programs; specifically, the FDOT and FDOTMono true type fonts (ttf). These fonts are stored in the *FDOT.ttf* and *FDOTMono.ttf* files supplied with the Department's CADD Software.

The *zDOTFont.rsc* and *StructuresFont.rsc* resource files are delivered in the MicroStation CADD Software Suite providing support for legacy MicroStation fonts 168, 169, 68, and 69. Legacy MicroStation fonts should not be used for new production work.

## 4.22.7 Colors

Colors depend on the color table attached to the design file. Therefore, it is important that "*color.tbl*" provided by Bentley (shipped with MicroStation) is attached to all structures design files.

## 4.22.8 Special Symbols

Special symbol characters are provided in the Department's true type font files. These characters may be accessed via the Insert Symbol tool provided in the MicroStation Text Editor/Word Processor or AutoCAD MText editor dialog.

These characters include, but are not limited to: fractions, mathematical symbols, survey symbols, boring symbols, Greek letters, Super/Sub Scripts.

## 4.22.9 Dimension Settings

Dimension styles are defined in the *strslevels.dgnlib* (MicroStation) or Structures Template files (AutoCAD). Styles are provided for Dimensioning and Notes for various terminators and leaders. Make every effort to use automatic dimensioning with element association enabled.

## 4.22.10 Reference Files

Information from other disciplines, such as Roadway, and Utilities, should not be copied into Structures design files, as they will be flagged as invalid by the QC Software and adversely affect the Standards Compliance Report.

When it is necessary to use or present this type of information, reference it into the Structures design file using relative paths.

## 4.22.11 Existing Bridge Plans

The January 2014 *Structures Detailing Manual* Section 3. 3.1 B it states the following:

*"At the end of the plan set, place all existing bridge sheets for Structures Detailing Manual Topic No. 625-020-018 3 - Composition of Plan Set January 2014 3-2 Structures Manual Home each bridge in one PDF file named "B1ExistingPlans.pdf" for the first bridge (number sheets sequentially "BX1-1", "BX1-2", etcetera) and "B2ExistingPlans.pdf" for the second bridge, etcetera."*

Traditionally existing Bridge Plans have been made as a part of the contract documents and therefore should be made part of the plans set. Likewise the PDF file(s) representing the existing Bridge Plans would reside in the \struct\ project folder.

**Note** The person responsible for assembling the plan set including existing bridge plans may wish to apply a stamp on each existing bridge plan sheet that indicates "FOR INFORMATION ONLY" and the current contract FPID being designed.

## 4.23 UTILITIES STANDARDS

This chapter defines guidelines for sharing data between the District Offices and the Utility Agency/Owner (UAO).

### 4.23.1 Utility File Coordination Options

There are three options available for the UAO to share files with the Department:

- Exchange of design files (DGN or DWG) – the preferred option
- Create American Standard Code for Information Interchange (ASCII) files
- Import of Geographic Information System (GIS) data

➤ **Sharing of Design Files**

Design files are created to the Department’s CADD Standards and returned to the District for review. The UAO will use these files as references to create the existing or proposed utility files. These files (existing or proposed) would also be submitted back to the District. It is the District’s responsibility to coordinate with the UAO for delivery of design files. For AutoCAD DWG files, all line work for utilities should be preferably in 3D and saved as polylines or feature line objects.

➤ **ASCII Input File**

The second option is the ASCII file that can be created from existing or proposed utilities. The ASCII file format will be either LandXML or GEOPAK input format for Station/Offset/Elevation or Northing/Easting/Elevation (State Plane coordinates). These files must contain information pertinent to the location of the utility, as well as the type of utility and where it is located referenced to the (survey baseline) alignment or state plane coordinates.

➤ **Geographic Information System (GIS) File**

In the event that a UAO maintains a GIS database of utility data, that data may be exchanged in GIS shape files.

### 4.23.2 Utility Coordination

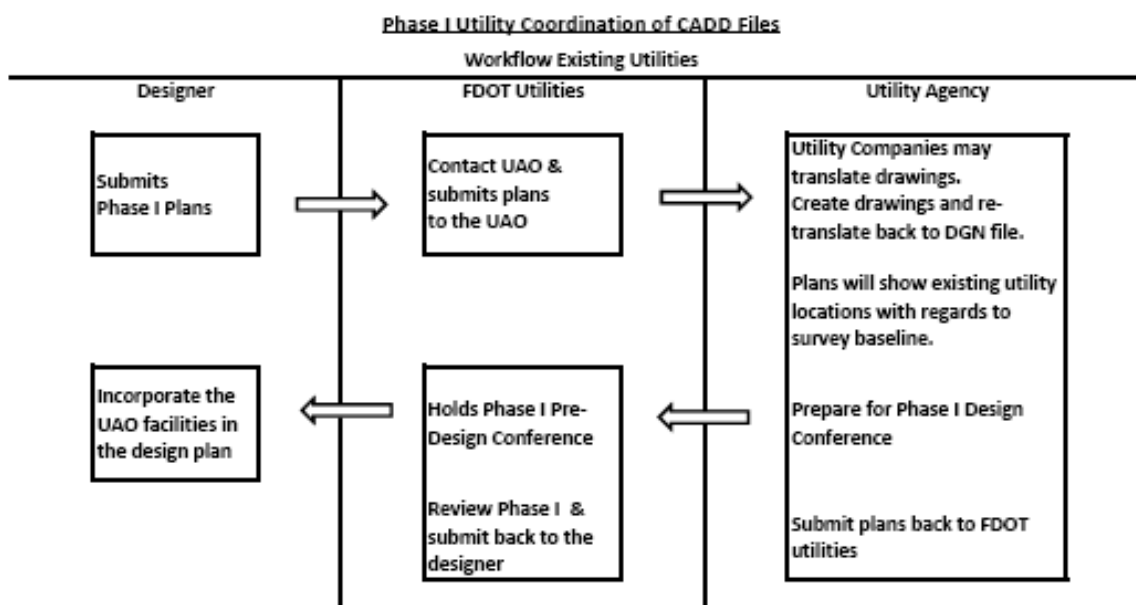



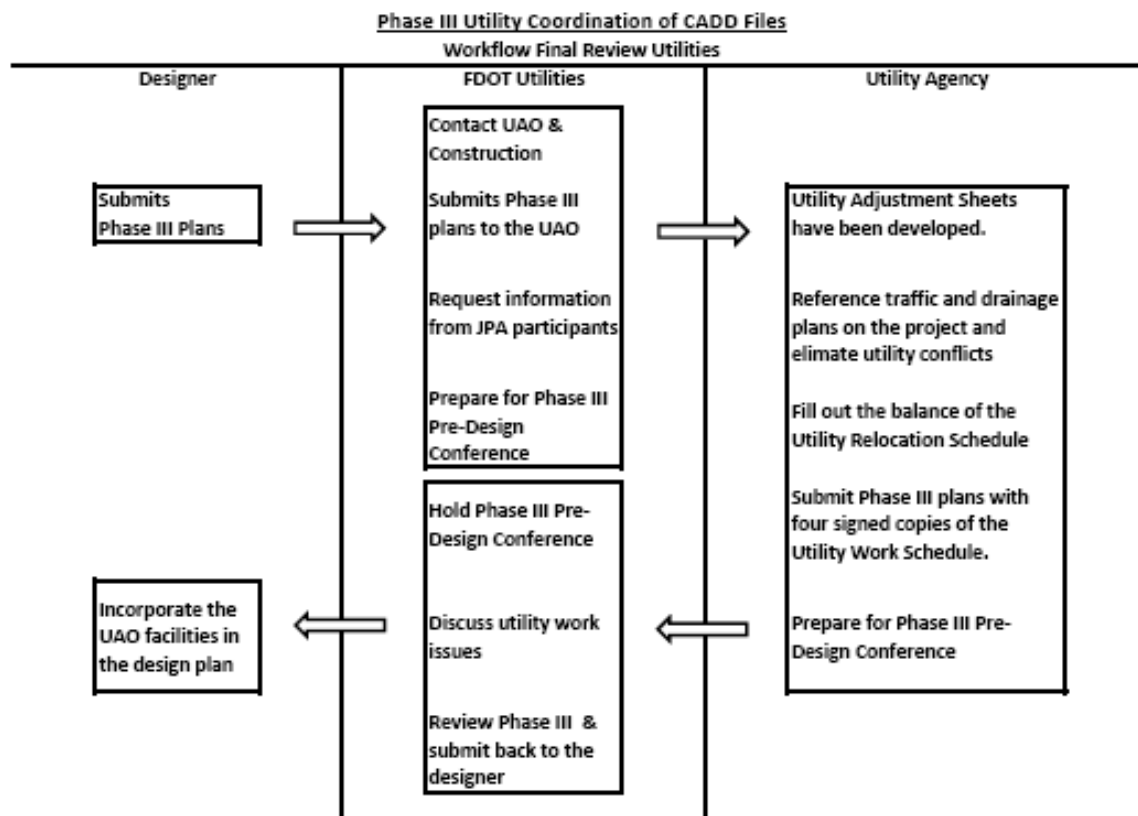
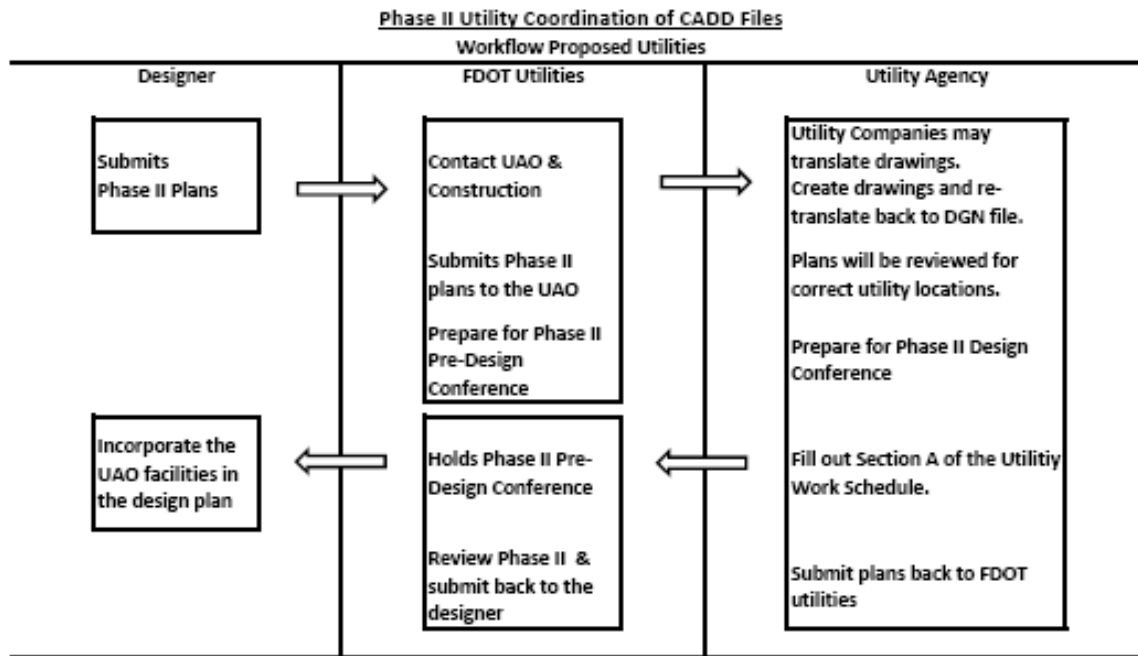

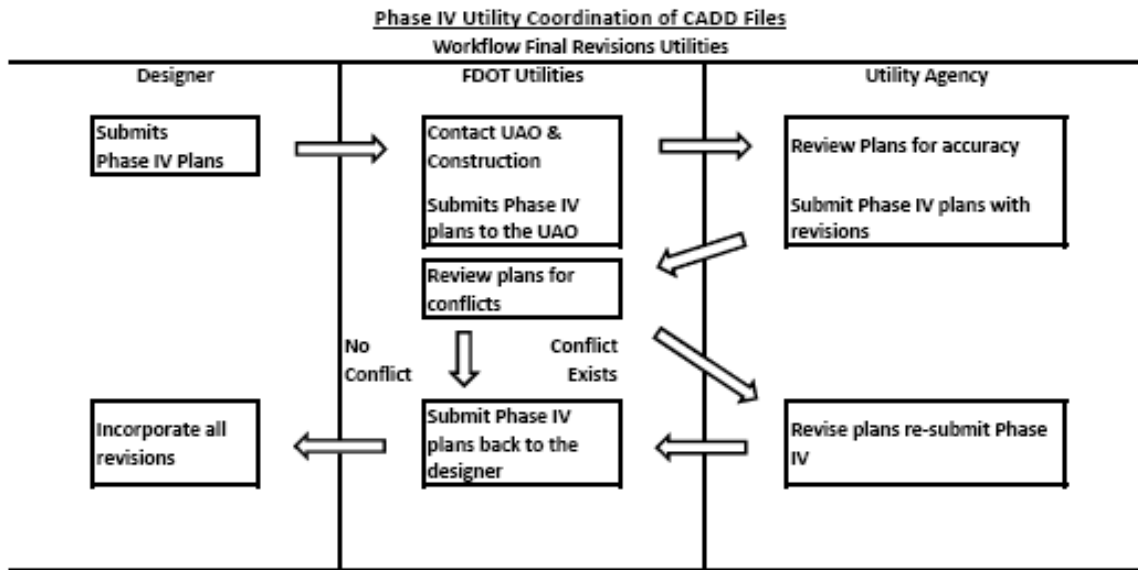

### 4.23.3 Exchange of Design Files

After the Department’s District Utilities Office (via Utility Coordinator) has received the current phase submittal from the Designer, they must contact the involved utilities and notify them of the phase submittal. The UAO will then receive the phase documents from the Department that must contain the Roadway Plans, the necessary CADD files and any Utility Relocation Agreements and Schedules. The required electronic files include the proposed roadway design; the existing topography, the existing and proposed R/W and the existing utilities gathered from the survey and previously supplied data.

No editing of any files provided by the Department will be accepted. The UAO will be placing data into newly created files. File naming standards must be maintained at all times.

### 4.23.4 Standard File Names

The Department utilizes standard naming conventions for all of its files and provides automated tools that depend on this naming convention. The naming convention confers data information to the downstream customer of the files.

➤ **Standard file names should follow this format: AAAABB##.ext**

Where **AAAA** = abbreviated file description, **BB** = Discipline Denotation, **##** =Sequence number.

If the Utility work is accomplished by a Highway Contractor as a separate contract (UWHC plans), the discipline designation for the file name is “UW”.

For example, a MicroStation design file for utility adjustment would be named: *utaduw01.dgn*.

If the Utility adjustments are included in the Roadway Plan set the discipline designation for the file name is “RD”. For example, a utility adjustment file name would be *utadrd01.dgn*. See Section 4.17 Roadway Standards for the Utilities Standard File Names defined for use by Roadway Design.

**Note** See Section 4.8 of this document for more information about Standard File Names. See Appendix A for the complete listing of level/symbology standards for each applicable CADD Standard Rule.

The following table defines the Utility File names with each file including sequential numbering. Standard model names are also provided.

File Type	Critical	File Name	Model Name	File Description	Standard Rule	MicroStation Seed File	Civil 3D Template File
Borders & Sheets		BDPLUW##	default	UWHC Border Sheet Reference File for Plan Sheets	planrd	fdotseed2d.dgn	
Borders & Sheets		GNNTUW##	default	UWHC General Notes	planrd	fdotseed2d.dgn	fdotmaster.dwt
Borders & Sheets		PLANUW##	default	UWHC Plan Sheet	planrd	fdotseed2d.dgn	fdotmaster.dwt
Borders & Sheets		PLPRUW## (UTEXRD##)	default	UWHC Plan & Profile Sheet	plprrd	fdotseed2d.dgn	fdotmaster.dwt
Borders & Sheets		PROFUW##	default	UWHC Profile Sheet	plprrd	fdotseed2d.dgn	fdotmaster.dwt
Clipping		CLIPUW##	default	UWHC Clip Borders	cliprd	fdotseed2d.dgn	fdotmaster.dwt
Clipping		MTPLUW##	default	UWHC Motif file for plan sheets	planrd	fdotseed2d.dgn	fdotmaster.dwt
Clipping		MTPRUW##	default	UWHC Motif file for profile sheets	plprrd	fdotseed2d.dgn	fdotmaster.dwt
Existing Topography		TOPOUW##	default	Topography - Existing (No Utilities or Drainage included)	topord	fdotseed2d.dgn	survey.dwt
Key Sheets		KEYSUW##	default	UWHC Key Sheet	keysht	fdotseedkeymap.dgn	keysht.dwt
Proposed Design		DSPFUW##	default	Proposed Profile	plprrd	fdotseed2d.dgn	fdotmaster.dwt
Proposed Design		SIGNUW##	default	Digital Signatures	open	fdotseed2d.dgn	digitalsignature.dwt
Proposed Design		TEXTUW##	default	UWHC Text Labels & Miscellaneous Descriptions	planrd	fdotseed2d.dgn	
Proposed Design		CESSUW##	default	Summary of Pay Items Sheets	planrd	fdotseed2d.dgn	planrd.dwt
Utilities		UTADUW## (UTADR##)	default	UWHC Utility Adjustment Sheet	utardr	fdotseed2d.dgn	utardr.dwt
Utilities		UTDTUW##	default	UWHC Special Details	open	fdotseed2d.dgn	fdotmaster.dwt
Utilities	X	UTEXUW## (UTEXRD##)	default	UWHC Utilities – Existing	utexrd	fdotseed2d.dgn	survey.dwt
Utilities	X	UTPRUW## (UTPRRD##)	default	UWHC Utilities – Proposed	utprrd	fdotseed2d.dgn	utprrd.dwt
Verified Utilities		SBVHUW##	default	UWHC Summary of Verified Utilities (2D)	planrd	fdotseed2d.dgn	fdotmaster.dwt
Verified Utilities	X	UTVHUW##	default	UWHC Survey of Verified Utilities (3D version of UTEXRD.dgn)	utexrd	fdotseed3d.dgn	survey.dwt

### 4.23.5 Utility Work by Highway Contractor Agreement Plans

Major highway construction elements such as pavement areas, bridges, drainage structures, right of way, lane widths, control of access limits and highway-straight-line numbers should appear in the Utility Work by Highway Contractor Agreement Plans.

The Department’s plans marked by the UAO will use the following color code:

- **Red:** Existing utilities either (a) To be removed or relocated horizontally or (b) to be placed out-of-service (deactivated) but left in place.
- **Green:** Existing utilities to remain in place with no adjustment.
- **Brown:** Either (a) Existing utilities to be adjusted vertically but to remain in the same horizontal alignment, or (b) Completely new utilities to be installed.

One set of the plans should be returned to the Department with each copy of the Utility Agreement.

## 4.23.6 ASCII Files of Utility Data

ASCII Files of utility data are to be exchanged in the LandXML format which is ubiquitous with most civil design and GIS software. Information about LandXML can be found at: <http://www.LandXML.org>.

➤ **The File Naming Convention for this ASCII files must be:**

- *utilx##.xml* for Existing Utilities
- *utilpr##.xml* for Proposed Utilities

➤ **Alternately, ASCII files of Utility Data File Naming Convention must be:**

- *utilx##.inp* for Existing Utilities. Note .inp extension for GEOPAK input
- *utilpr##.inp* for Proposed Utilities. Note .inp extension for GEOPAK input

Where ## will be a sequencing number (01, 02, 03, etcetera).

Each electronic ASCII report file must be stored on media according to the Department's CADD Deliverable Standards. If the provider does not have capability to deliver in LandXML format, a GEOPAK Input format file will also be an acceptable substitute. When delivery is made in GEOPAK Input format, the ASCII report must be accompanied by a printed hardcopy.

## 4.23.7 Utility Scanned Images

If the Utilities are handled through a Joint Utility Agreement and electronic files are not provided to the District for the Utility plans, the paper plans must be scanned. The format must be a published format with a minimum resolution of 300DPI. The required formats are PDF or Group 4 TIFF.

## 4.24 GEOTECHNICAL STANDARDS

Geotechnical Plans are included in the Roadway Plan Set as Soil Survey, Soil Boring and Bridge Data Sheets.

### 4.24.1 Standard File Names

The Department utilizes standard naming conventions for all of its files and provides automated tools that depend on this naming convention. The naming convention confers data information to the downstream customer.

➤ **Standard file names should follow this format: AAAABB##.ext**

Where **AAAA** = *abbreviated file description*, **BB** = *Discipline Denotation*, **##** = *Sequence number*.

Files that are associated with specific bridges must be prepended with a B# prefix corresponding to the appropriate bridge number.

**Note** See Section 4.8 of this document for more information about Standard File Names. See Section 4.23 Structures Standards of this document for bridge specific filenames & sheet numbering requirements. See Appendix A for the complete listing of level/symbology standards for each applicable CADD Standard Rule.

The following table defines the Geotechnical Standard File Names for Department projects. Each file name must include sequence numbering. Standard Model names are also provided.

File Type	Critical	File Name	Model Name	File Description	Standard Rule	MicroStation Seed File	Civil 3D Template File
Geotech		clvgeo##	default	Box Culvert Auger & SPT Borings	geotech	fdotseed2d.dgn	fdotmaster.dwt
Geotech		ltgeo##	default	Lighting Borings	geotech	fdotseed2d.dgn	fdotmaster.dwt
Geotech		mtgeo##	default	Mitigation Borings	geotech	fdotseed2d.dgn	fdotmaster.dwt
Geotech		pdgeo##	default	Pond Borings	geotech	fdotseed2d.dgn	fdotmaster.dwt
Geotech		rdgeo##	default	Augers Borings	geotech	fdotseed2d.dgn	fdotmaster.dwt
Geotech		rdssgeo##	default	Roadway Soil Survey Sheet	geotech	fdotseed2d.dgn	fdotmaster.dwt
Geotech		sggeo##	default	Signal SPT Borings	geotech	fdotseed2d.dgn	fdotmaster.dwt
Geotech		snggeo##	default	Signs SPT Borings	geotech	fdotseed2d.dgn	fdotmaster.dwt
Roadway		cptgeo##	default	CPT Soundings	geotech	fdotseed2d.dgn	fdotmaster.dwt
Roadway		msewgeo##	default	MSE Wall SPT Borings	geotech	fdotseed2d.dgn	fdotmaster.dwt
Roadway		nwgeo##	default	Noise Wall SPT Borings	geotech	fdotseed2d.dgn	fdotmaster.dwt
Roadway		rtwgeo##	default	Retaining Wall SPT Borings	geotech	fdotseed2d.dgn	fdotmaster.dwt
Roadway		spgeo##	default	Sheet Pile Wall SPT Borings	geotech	fdotseed2d.dgn	fdotmaster.dwt
Structures		B#BORING##	default	Report of Core Borings	geotech	StructuresSeed.dgn	StructuresTemplatePlan.dwt
Structures		B#CPTGEO##	default	CPT Soundings	geotech	StructuresSeed.dgn	StructuresTemplatePlan.dwt
Structures		B#MSEWGEO##	default	MSE Wall SPT Borings	geotech	StructuresSeed.dgn	StructuresTemplatePlan.dwt
Structures		B#NWGEO##	default	Noise Wall SPT Borings	geotech	StructuresSeed.dgn	StructuresTemplatePlan.dwt
Structures		B#RTWGEO##	default	Retaining Wall SPT Borings	geotech	StructuresSeed.dgn	StructuresTemplatePlan.dwt
Structures		B#SPGEO##	default	Sheet Pile Wall SPT Borings	geotech	StructuresSeed.dgn	StructuresTemplatePlan.dwt

## 4.24.2 Engineering Data

Engineering Data delivered with each project must be located in the `\eng_data\ sub-` folder and include:

- ASCII files containing Q/C reports
- All computer input and output files used in the design (in native file formats for the software used and printed to PDF format)
- All supplemental design hand calculations (scanned and saved in PDF or TIFF file formats)
- Soil boring data

The sheet image from the design files and image files of all other output files from the design and/or analysis programs must be in PDF format. The PDF of the plan sheets must follow the conventions of Digital Delivery. Computer input and output files include files used for all aspects of analysis and design. Geotechnical information must also be delivered (CSV format) as shown in the examples below. The Department has adopted the following standard file naming convention for CSV file imports for the Geotechnical Utility in GEOPAK:

- **Borehole** - *Boreholetpk.brh* - Borehole location data, seasonal high water & design high water data.
- **Material** - *Material.mtl* - Strata Data and Core data.

Standard Penetration Test (SPT) boring information may be drawn using the Department's Report a Core Boring Tool.

➤ **Example: Boreholetpk.brh**

Format: *borehole\_name,alignment\_name,station,offset,water\_elev\_type,water\_elev\_0,water\_elev\_0\_date,water\_elev\_24,water\_elev\_24\_date*

Examples:       Borehole-01,CLCON,78+00.00,15,0,3,8/9/2007,5,8/10/2007  
                  Borehole-02,CLCON,80+00.00,3,0,2,8/20/2007,4,8/21/2007  
                  Borehole-03,CLCON,83+00.00,3,0,3,8/23/2007,5,8/24/2007  
                  Borehole-04,CLCON,85+00.00,4,0,2,8/24/2007,4,8/25/2007

➤ **Example: Material.mtl**

Format: *borehole\_name,material\_name,doc\_or\_se,type\_of\_elev*

Examples:       Borehole-01,1,10,DOC  
                  Borehole-02,1,5,DOC  
                  Borehole-02,2,7,DOC  
                  Borehole-02,3,9,DOC  
                  Borehole-03,1,3,DOC  
                  Borehole-03,2,6,DOC  
                  Borehole-04,1,2,DOC  
                  Borehole-04,2,5,DOC  
                  Borehole-04,3,7,DOC  
                  Borehole-04,4,10,DOC

## 4.24.3 Soil Survey

The plans must include the information about the soil classification on the soil survey sheet and by showing the boring data soil boxes on the cross section sheets.

## 4.24.4 Soil Boring Data

The soil boring data must be provided to the Roadway designer in a format to facilitate the drawing of the data on the cross section sheets.

**Note** For help and instructions on specific functions and use of GEOPAK's Geotechnical Tool, refer to the GEOPAK help file.

## 4.25 CONSTRUCTION STANDARDS

The use and generation of CADD files by Construction must be in accordance with the general standards applied to all disciplines.

### 4.25.1 Standard File Names

The Department utilizes standard naming conventions for all of its files and provides automated tools that depend on this naming convention. The naming convention confers data information to the downstream customer.

➤ **Standard file names should follow this format: AAAABB##.ext**

Where **AAAA** = *abbreviated file description*, **BB** = *Discipline Denotation*, **##** = *Sequence number*.

The standard file names defined by the design discipline must be applied for CADD files generated in Construction, except the portion defining the discipline must be “CN” instead of “RD”. Example: *DSGNRD01.DGN* must be *DSGNCN01.DGN*.

Standard Model names are also provided, however, it is not mandatory to use more than the default model, with the exception of those listed in this table.

**Note** See Section 4.8 of this document for more information about Standard File Names. See Appendix A for the complete listing of level/symbology standards for each applicable CADD Standard Rule.

File Type	Critical	File Name	Model Name	File Description	Standard Rule	MicroStation Seed File	Civil 3D Template File
Cross Sections	X	PDXSCN##	rdxsrd	Pond Cross Sections	rdxsrd	fdotseedxs.dgn	fdotmaster.dwt
Cross Sections	X	RDXSCN##	rdxsrd	Roadway Cross Sections	rdxsrd	fdotseedxs.dgn	fdotmaster.dwt
Drainage	X	DREXCN##	default	Drainage Structures - Existing	drexrd	fdotseed2d.dgn	fdotmaster.dwt
Drainage	X	DRPRCN##	default	Drainage Structures - Proposed	drprrd	fdotseed2d.dgn	fdotmaster.dwt
Drainage	X	DRXSCN##	rdxsrd	Drainage Structure Cross Sections	rdxsrd	fdotseedxs.dgn	fdotmaster.dwt
Existing Topography		TOPOCN##	default	Topography - Existing	topord	fdotseed2d.dgn	survey.dwt
Proposed Design	X	DSGNCN##	default	Proposed Design	dsgnrd	fdotseed2d.dgn	fdotmaster.dwt
Proposed Design	X	DSPFCN##	default	Proposed Profile	plprrd	fdotseed2d.dgn	fdotmaster.dwt
Proposed Design		SIGNCN##	default	Digital Signatures	open	fdotseed2d.dgn	digitalsignature.dwt
Proposed Design	X	TEXTCN##	default	Text Labels & Miscellaneous Descriptions	planrd	fdotseed2d.dgn	
Traffic Control	X	TCDSCN##	default	Traffic Control Design	tcdsrd	fdotseed2d.dgn	fdotmaster.dwt
Utilities	X	UTEXCN##	default	Utilities - Existing	utexrd	fdotseed2d.dgn	survey.dwt
Utilities	X	UTPRCN##	default	Utilities - Proposed	utprrd	fdotseed2d.dgn	utprrd.dwt

## 4.26 INTELLIGENT TRANSPORTATION SYSTEMS STANDARDS

Intelligent Transportation Systems (ITS) Plans are usually a component set of plans. The Department's Projects with minor ITS involvement may include these features on various applicable sheets in the Roadway plans set. They can also be shown in the Signalization plans set or on applicable Signalization sheets.

### 4.26.1 Standard File Names

The Department utilizes standard naming conventions for all of its files and provides automated tools that depend on this naming convention being met. The naming convention confers data information to the downstream customer.

➤ ***Standard file names should follow this format: AAAABB##.ext***

Where **AAA** = abbreviated file description, **BB** = Discipline Denotation, **##** = Sequence number.

The following table defines the ITS standard file names for Department projects. Each file name must include sequential numbering. Standard model names are also provided, however, it is not mandatory to use more than the default model, with the exception of those listed in this table.

**Note** See Section 4.8 of this document for more information about Standard File Names. See Appendix A for the complete listing of level/symbology standards for each applicable CADD Standard Rule.

File Type	Critical	File Name	Model Name	File Description	Standard Rule	MicroStation Seed File	Civil 3D Template File
Borders & Sheets		BDPLIT##	default	Border Sheet Reference Model for Plan Sheet	planrd	fdotseed2d.dgn	
Borders & Sheets		BDXSIT##	rdxsrd	Border Cross-Section Sheet when Referenced	rdxsrd	fdotseedxs.dgn	
Borders & Sheets		GNNTIT##	default	General Notes	planrd	fdotseed2d.dgn	fdotmaster.dwt
Borders & Sheets		PLANIT##	default	Plan Sheet	planrd	fdotseed2d.dgn	fdotmaster.dwt
Borders & Sheets		PLAYIT##	default	Plan Layout Sheets	planrd	fdotseed2d.dgn	fdotmaster.dwt
Borders & Sheets		SPLYIT##	default	Splice Layout Sheets	planrd	fdotseed2d.dgn	fdotmaster.dwt
Clipping		CLIPIT##	default	Clip Borders	cliprd	fdotseed2d.dgn	fdotmaster.dwt
Clipping		MTPLIT##	default	Motif file for plan sheets	planrd	fdotseed2d.dgn	fdotmaster.dwt
Clipping		MTPRIT##	default	Motif file for profile sheets	plprrd	fdotseed2d.dgn	fdotmaster.dwt
Cross Sections	X	SSXSIT##	rdxsrd	Sign Support Cross-Sections	rdxssp	fdotseedxs.dgn	fdotmaster.dwt
Key Sheets		KEYSIT##	default	Key Sheet	keysht	fdotseedkeymap.dgn	keysht.dwt
Proposed Design	X	DSGNIT##	default	Proposed Signalization Design & information	itssp	fdotseed2d.dgn	fdotmaster.dwt
Proposed Design	X	DSLIT##	default	Proposed Lighting Design	itssp	fdotseed2d.dgn	fdotmaster.dwt
Proposed Design	X	DSPMIT##	default	Proposed Signing & Pavement Marking Design	itssp	fdotseed2d.dgn	fdotmaster.dwt
Proposed Design		INTDIT##	default	Intersection / Interchange Details	planrd	fdotseed2d.dgn	fdotmaster.dwt
Proposed Design		SIGNIT##	default	Digital Signatures	open	fdotseed2d.dgn	digitalsignature.dwt
Proposed Design		TEXTIT##	default	Text Labels & Miscellaneous Descriptions	planrd	fdotseed2d.dgn	
Special Details		GSWKIT##	default	Guide Sign Work Sheet & Details	gswksp	fdotseed2d.dgn	fdotmaster.dwt
Special Details		JCDTIT##	default	Jacking Detail Sheet	open	fdotseed2d.dgn	fdotmaster.dwt
Special Details		LUDTIT##	default	Luminaire Detail Sheet (All Types)	open	fdotseed2d.dgn	fdotmaster.dwt
Special Details		NWDIT##	default	Communications Network Details	open	fdotseed2d.dgn	fdotmaster.dwt
Special Details		NWLYIT##	default	Communications Network Layout/Block diagram	open	fdotseed2d.dgn	fdotmaster.dwt
Special Details		SGDTIT##	default	Special Signal Details	open	fdotseed2d.dgn	fdotmaster.dwt
Special Details		SPDTIT##	default	Splice Diagrams	open	fdotseed2d.dgn	fdotmaster.dwt



File Type	Critical	File Name	Model Name	File Description	Standard Rule	MicroStation Seed File	Civil 3D Template File
Special Details		SPSGIT##	default	Dynamic Message Sign Detail for Overhead Signs	open	fdotseed2d.dgn	fdotmaster.dwt
Special Details		SRPTIT##	default	Service Point Detail Sheets	itssp	fdotseed2d.dgn	fdotmaster.dwt
Special Details		SSDTIT##	default	Special Sign Details & Miscellaneous Details	planrd	fdotseed2d.dgn	fdotmaster.dwt
Special Details		VHDTIT##	default	Vehicle Detector Details & Instructions	itssp	fdotseed2d.dgn	fdotmaster.dwt
Summary Boxes / Tables		CESSIT##	default	Summary of Pay Items	planrd	fdotseed2d.dgn	planrd.dwt
Summary Boxes / Tables	X	MSSGIT##	default	Mast Arm Detail and Tables	itssp	fdotseed2d.dgn	fdotmaster.dwt
Summary Boxes / Tables		PLDTIT##	default	Pole Tabulation & Details for All Types	open	fdotseed2d.dgn	fdotmaster.dwt
Summary Boxes / Tables		SLBRIT##	default	Soil Borings for Poles & Overhead Structures	geotech	fdotseed2d.dgn	fdotmaster.dwt
Summary Boxes / Tables		TABQIT##	default	Tabulation Quantity Sheet	planrd	fdotseed2d.dgn	fdotmaster.dwt
Traffic Control		TCDTIT##	default	Traffic Control Design Sheet	itssp	fdotseed2d.dgn	fdotmaster.dwt
Utilities		UTADIT##	default	Utility Adjustment Sheets	utadrd	fdotseed2d.dgn	utadrd.dwt

## 4.27 ARCHITECTURAL STANDARDS

Architectural plans consist of all sheets pertaining to Architectural (Building) design, and their component plans. These plans may be comprised of any/all of:

- General Plans
- Hazardous Materials Plans
- Survey Plans (Following the Survey CADD Standards)
- Geotechnical Plans (Following the Geotechnical CADD Standards)
- Civil Plans (Following the Roadway CADD Standards)
- Landscape Plans (Following the Landscape CADD Standards)
- Structural Plans
- Architectural Plans
- Interior Plans
- Fire Protection Plans
- Plumbing Plans
- Mechanical Plans
- Electrical Plans

The bullets above represent an Architectural plan set on a Department Project where the building is the focal point of the project. Architectural (often referred to as “Building”) projects within the Right of Way typically do not include Survey, Civil, Geotechnical, or Landscape plans. These disciplines are normally included in the Roadway Plans. However, when present in the Architectural plans, the Department’s CADD Standards of the appropriate discipline must be used.

Bascule Bridge Control House Architectural plans are to be prepared using the Department’s Structures CADD Standards.

### 4.27.1 Adopted CADD File Format

The Department has adopted AutoCAD as the Standard platform format for Architectural projects. All CADD files for Architectural plan sets, including those disciplines within the building (i.e. plumbing, mechanical, electrical and structural) will be submitted in AutoCAD (.dwg) format. Plans outside the building envelope must follow the Department’s CADD Standard format for the discipline as defined in their respective Sections.

## 4.27.2 Adopted CADD Standards

The Department has adopted the National CAD Standards as the standard format for Building Projects. This Section is a synopsis of the National CAD Standards. More information can be found at:

National CAD Standard  
National Institute of Building Sciences  
1090 Vermont Ave., NW, Suite 700  
Washington, D.C. 20005-4905  
(202) 289-7800  
Website: <http://www.nationalcadstandard.org/ncs6/>

National Cad Standard also includes chapters from the following organizations:

U.S.CADD/GIS Technology Center  
US Army Engineer Research and Development Center  
Attn: CEERD-ID (S. Spangler)  
3909 Halls Ferry Road  
Vicksburg, MS 39180-6199  
Website: <http://www.erd.usace.army.mil/>

CAD Layer Guidelines  
American Institute of Architects (AIA)  
1735 New York Ave, NW  
Washington, D.C. 20006  
Website: [www.aia.org](http://www.aia.org)

Uniform Drawing System (UDS)  
Construction Specifications Institute  
601 Madison Street  
Alexandria, Va. 22314-1791  
800-689-2900  
Website: <http://www.csinet.org>

## 4.27.3 Architectural Projects

Architectural standards apply to the building and building related disciplines outlined in the following list of project types.

- **Building Projects:**
  - Work Program Projects
    - Rest Areas
    - Weigh Stations
  - Fixed-Capital Outlay (FCO) Projects
    - Office Buildings
    - Construction & Maintenance Facilities
    - Other 'Off Right Of Way (ROW)' Facilities

## 4.27.4 Delineation between Architectural & Engineering Plans

### ➤ **Delineation Line at 'foot print' of Building:**

- Face of Exterior Wall
- Area enclosed by buildings Columns and/or Walls; i.e. Porticos, Carports, covered Walkways and Covered Patios
- Roof and Building Overhangs

Use AutoCAD *inside* the Delineation Line. Items inside the Delineation Line Includes 'Building-Oriented' Facilities & Equipment that are typically designed by an Architect, including but not limited to, picnic shelters, planters which are part of the building and site furniture in covered areas.

### CADD Delineation Example

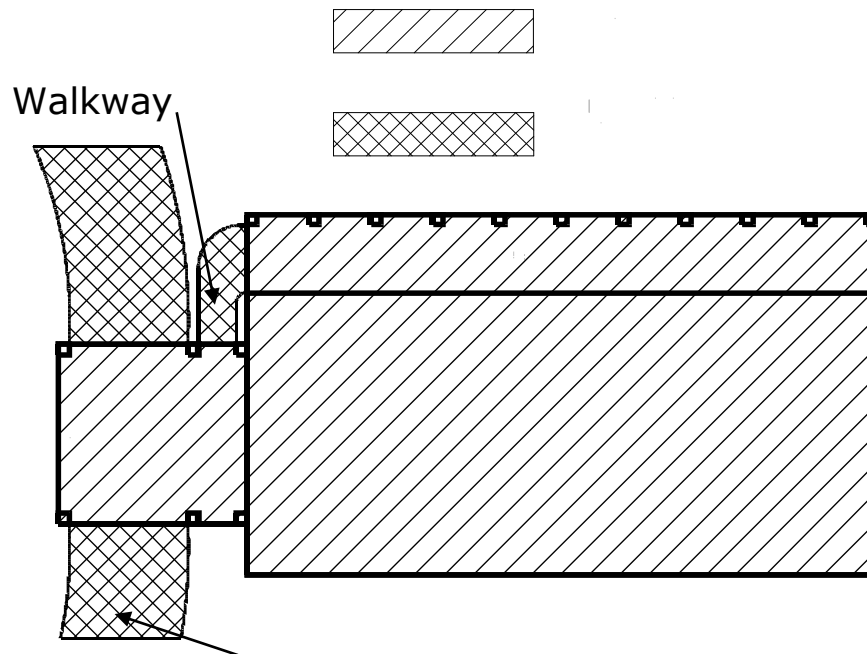

Items outside the delineation or "foot print" of Building must be produced and submitted following the CADD standards for their discipline as defined in their respective chapters, including but not limited to:

- Pavement
  - Driveways, Parking, Sidewalks
- Landscape Plans
- Site Utilities
  - Electrical, Water, Sanitary Sewer, Storm Sewer, Drainage
- Site Fencing and Walls

## 4.27.5 Standard File Names

AutoCAD files are 3D for large plans, elevations or sections that contain the physical building components (walls, doors, water piping, beams...). These files are drawn in Model Space at full scale. These files are referenced in whole or part into sheet files where text and dimensions are added, then printed.

➤ **Naming Components:**

- Architectural Projects Identifier
- Discipline Codes
- Drawing Type Codes (General and Discipline related)
- File Sequence Number

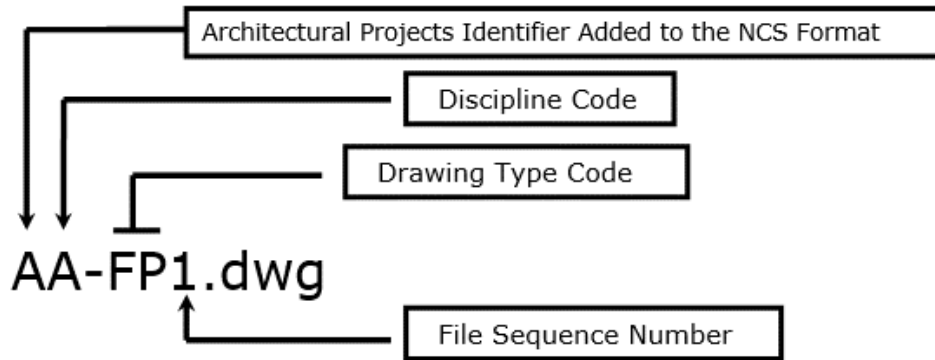

**Note** Architectural Projects Identifier: A \_ \_ \_ .dwg  
 Add "A" before Discipline Code as published in National CAD Standards. This distinguishes Building drawings from Roadway and Structures Plans.

**Examples:** Project Identifiers, Codes and File Sequence Numbers. For more detailed information refer to National CAD Standards.

- **Architectural Project Identifier**

A \_ \_ \_ .dwg Architectural, this differentiates architectural building projects from bridges and roadway projects.

- **Discipline Code**

_A- _ _ .dwg	.....	Architectural
_C- _ _ .dwg	.....	Civil
_Z- _ _ .dwg	.....	Contractor/Shop Drawings
_Q- _ _ .dwg	.....	Equipment
_E- _ _ .dwg	.....	Electrical
_A- _ _ .dwg	.....	Architectural
_C- _ _ .dwg	.....	Civil
_Z- _ _ .dwg	.....	Contractor/Shop Drawings
_Q- _ _ .dwg	.....	Equipment
_M- _ _ .dwg	.....	Mechanical
_X- _ _ .dwg	.....	Other Disciplines
_P- _ _ .dwg	.....	Plumbing
_D- _ _ .dwg	.....	Process
_R- _ _ .dwg	.....	Resources
_S- _ _ .dwg	.....	Structural
_T- _ _ .dwg	.....	Telecommunications

- **Drawing Type Code** (*general and discipline related*)

__-FP_.dwg	.....	Floor Plan
__-SP_.dwg	.....	Site Plan
__-DP_.dwg	.....	Dimension Plan
__-XP_.dwg	.....	Existing Plan
__-EL_.dwg	.....	Elevation
__-SC_.dwg	.....	Section
__-DT_.dwg	.....	Detail
__-CP_.dwg	.....	Ceiling Plan
__-EP_.dwg	.....	Enlarged Plan
__-NP_.dwg	.....	Finish Plan
__-RP_.dwg	.....	Furniture Plan
__-SH_.dwg	.....	Schedules
__-3D_.dwg	.....	Isometric/3D
__-DG_.dwg	.....	Diagrams

- **File Sequence Number**

__- 1.dwg	.....	1st drawing file in sequence
__- 2.dwg	.....	2nd drawing file in sequence
__- 3.dwg	.....	3rd drawing file in sequence

#### 4.27.6 Standard Sheet File Names

A sheet file is a border sheet with dimensions and/or text added to a portion of a referenced model space file. Plotted sheet files make up the plans set.

➤ **Naming Components**

- Architectural Projects Identifier
- Discipline Code
- Sheet Type Code
- Sheet Sequence Number

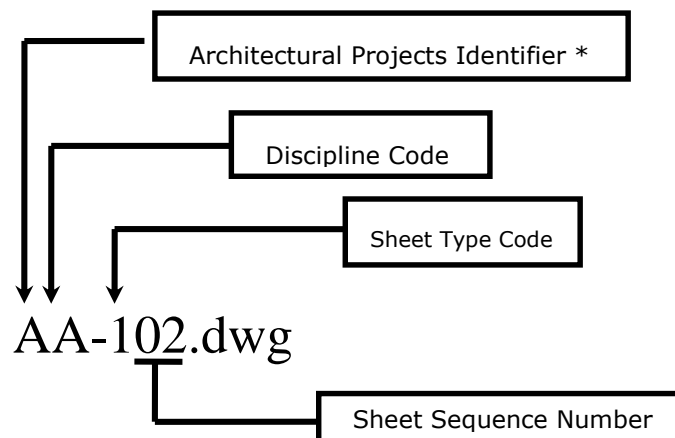

**Examples:** Project Identifiers, Codes and Sheet File Sequence Numbers. For more detailed information refer to National CAD Standards.

- **Architectural Project Identifier**

A \_ \_ \_ .dwg.. Architectural, this differentiates Architectural building projects from bridges and Roadway projects.

- **Discipline Code**

_A- _ _ .dwg .....	Architectural
_C- _ _ .dwg .....	Civil
_Z- _ _ .dwg .....	Contractor/Shop Drawings
_Q- _ _ .dwg .....	Equipment
_E- _ _ .dwg .....	Electrical
_F- _ _ .dwg .....	Fire Protection
_G- _ _ .dwg .....	General
_B- _ _ .dwg .....	Geotechnical
_H- _ _ .dwg .....	Hazardous Materials
_I- _ _ .dwg .....	Interiors
_M- _ _ .dwg .....	Mechanical
_X- _ _ .dwg .....	Other Disciplines
_P- _ _ .dwg .....	Plumbing
_D- _ _ .dwg .....	Process
_R- _ _ .dwg .....	Resources
_S- _ _ .dwg .....	Structural
_T- _ _ .dwg .....	Telecommunications

- **Drawing Type Code** (*general and discipline related*)

_ _ 0 _ _ .dwg .....	General (symbols, legend, notes...)
_ _ 1 _ _ .dwg .....	Floor Plan
_ _ 2 _ _ .dwg .....	Elevation
_ _ 3 _ _ .dwg .....	Sections
_ _ 4 _ _ .dwg .....	Large Scale
_ _ 5 _ _ .dwg .....	Details
_ _ 6 _ _ .dwg .....	Schedules and Diagrams
_ _ 7 _ _ .dwg .....	User Defined
_ _ 8 _ _ .dwg .....	User Defined
_ _ 9 _ _ .dwg .....	3D Views (isometrics, perspectives...)

- **File Sequence Number**

_ _ 01.dwg .....	1st sheet in sequence
_ _ 02.dwg .....	2nd sheet in sequence
_ _ 03.dwg .....	3rd sheet in sequence

➤ ***Detail File Name Format***

The Detail File Name includes the sheet identifier and the detail identification number. Sheet Identifier is the sheet file that the detail is placed in. The detail identification number represents the location of the detail within the sheet file border.

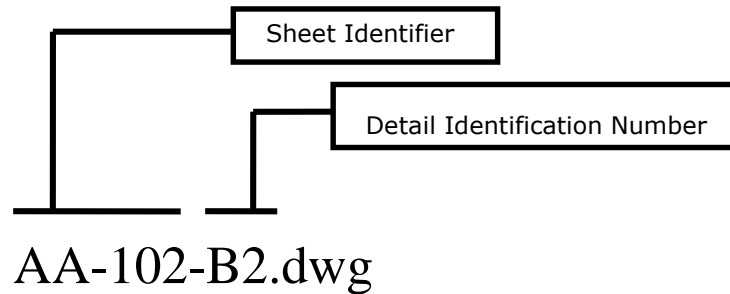

➤ ***Schedule File Name Format***

The Schedule File Name includes the sheet identifier and the schedule identification number. Sheet Identifier is the sheet file that the detail is placed in. The detail identification number represents the location of the schedule within the sheet file border.

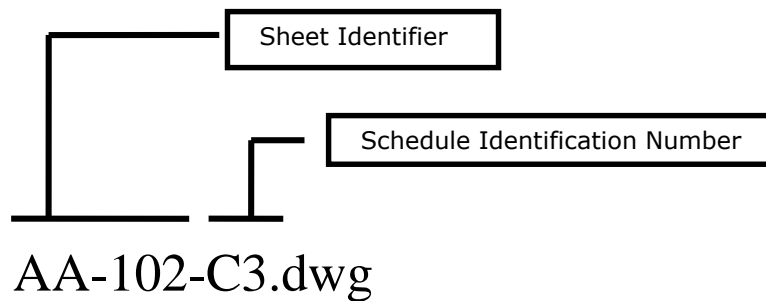

### 4.27.7 Engineering Data

The Architectural discipline folder contains an additional sub-folder named **\eng\_data\**. This sub-folder is designated to contain the sheet image files (PDF's) of the plan sheets for the Architecture design, quality control reports, ASCII Engineering Data output files and other data pertinent to the overall design.

### 4.27.8 Layers and Symbology

Refer to the National CAD Standards and Layer Symbology produced by the U.S.CADD/GIS Technology Center, US Army Engineer Research and Development Center for Symbology standards. These standards include space file names, sheet file names, detail file names, schedule file names, abbreviations, symbols, layers, linetypes, and text styles.

All drawings must be drawn at Full Scale 1:1 in Modelspace using Architectural Units. Text and dimensions should be added in Modelspace. The Titleblock Sheet should be in Paperspace and viewport scaled for scalable printing.

## 4.27.9 Architectural Scale Chart

The following chart is intended to aid the user in determining the appropriate scale for placing the border and text on a drawing based on the actual size of the drawing. Calculations are based on a 9 1/2" x 15 1/2" drawing area inside the border.

Drawing Scales for Sheets			
Note: Sheet files must be assembled in paper space & printed at 1:1			
Architectural Scales		Engineering Scales	
Drawing Scale	Plot Scale	Drawing Scale	Plot Scale
Full size	1	1" = 5'	60
6" = 1'-0"	2	1" = 10'	120
3" = 1'-0"	4	1" = 20'	240
1 1/2" = 1'-0"	8	1" = 30'	360
1" = 1'-0"	12	1" = 40'	480
3/4" = 1'-0"	16	1" = 50'	600
1/2" = 1'-0"	24	1" = 100'	1200
3/8" = 1'-0"	32	1" = 200'	2400
1/4" = 1'-0"	48	1" = 500'	6000
3/16" = 1'-0"	64	1" = 1000'	12000
1/8" = 1'-0"	96	1" = 1250'	15000
3/32" = 1'-0"	128	1" = 2500'	30000
1/16" = 1'-0"	192	1" = 5000'	60000

➤ **FORMULAS:**

AS = 12 x Drawing Scale, Ex. 1" = 10', then 12 x 10 = 120, Therefore AS = 120.

## 4.27.10 Text Type, Size and Line Weight

Use the following table to determine the appropriate line weight for each text height. Text line weights are applicable for text places in model and sheet files. Text heights in this chart are used for text in sheet files that are places in paper space.

Text Type	Line Weight (In) All Scales	Height (In) 1:1 Scale
Special Small/Revisions	0.007 in	3/32"
Annotation	0.010 in	1/8"
View/Sheet/Sect Titles	0.014 in	5/32"
Large	0.020 in	3/16"

**Note** Sizes shown are a 1:1 ratio.



The following charts are intended to aid the user in determining the appropriate text size when placing common text. Scale for placing the border and text on a drawing based on the actual size of the drawing. Calculations are based on a 9 1/2" x 15 1/2" drawing area inside the border.

<b>Text Size for Sheets Using Architectural Scales</b>				
<i>Note</i>		For text placed in model files, text in paper space at 1:1		
<b>Drawing Scale</b>	<b>Text Size</b>			
	3/32"	1/8"	5/32"	3/16"
Full size	3/32"	1/8"	5/32"	3/16"
6" = 1'-0"	3/16"	1/4"	5/16"	3/8"
3" = 1'-0"	3/8"	1/2"	5/8"	3/4"
1 1/2" = 1'-0"	3/4"	1"	1 1/4"	1 1/2"
1" = 1'-0"	1 1/8"	1 1/2"	1 7/8"	2 1/4"
3/4" = 1'-0"	1 1/2"	2"	2 1/2"	3"
1/2" = 1'-0"	2 1/4"	3"	3 3/4"	4 1/2"
3/8" = 1'-0"	3"	4"	5"	6"
1/4" = 1'-0"	4 1/2"	6"	7 1/2"	9"
3/16" = 1'-0"	6"	8"	10"	1'
1/8" = 1'-0"	9"	1'-0"	1'-3"	1'-6"
3/32" = 1'-0"	1'	1'-4"	1'-8"	2'
1/16" = 1'-0"	1'-6"	2'	2'-6"	3'

<b>Text Size for Sheets Using Engineering Scales</b>				
<i>Note</i>		For text placed in model files, text in paper space at 1:1		
<b>Drawing Scale</b>	<b>Text Size</b>			
	3/32"	1/8"	5/32"	3/16"
1" = 5'	5 5/8"	7 1/2"	9 3/8"	11 1/4"
1" = 10'	11 1/4"	1'-3"	1'-6 3/4"	1'-10 1/2"
1" = 20'	1'-10 1/2"	2'-6"	3'-1 1/2"	3'-9"
1" = 30'	2'-9 3/4"	3'-9"	4'-8 1/4"	5'-7 1/2"
1" = 40'	3'-9 1/2"	5'	6'-3"	7'-6"
1" = 50'	4'-8 1/4"	6'-3"	7'-9 3/4"	9'-4 1/2"
1" = 100'	9'-4 1/2"	12'-6"	15'-7 1/2"	18'-9"
1" = 200'	18'-9"	25'	31'3"	37'-6"
1" = 500'	46'-10 1/2"	62'-6"	78'-1 1/2"	93'-9"
1" = 1000'	93'-9"	125'	156'-3"	187'-6"
1" = 1250'	117'-2 1/4"	156'-3"	195'-3 3/4"	234'-4 1/2"
1" = 2500'	234'-4 1/2"	306'-6"	390'-7 1/2"	468'-9"
1" = 5000'	468'-9"	625'	781'-3"	937'-6"

## 4.27.11 Layer Names

All layer names must follow the format detailed in the National CAD Standards. Below is a brief description of the layer naming convention.

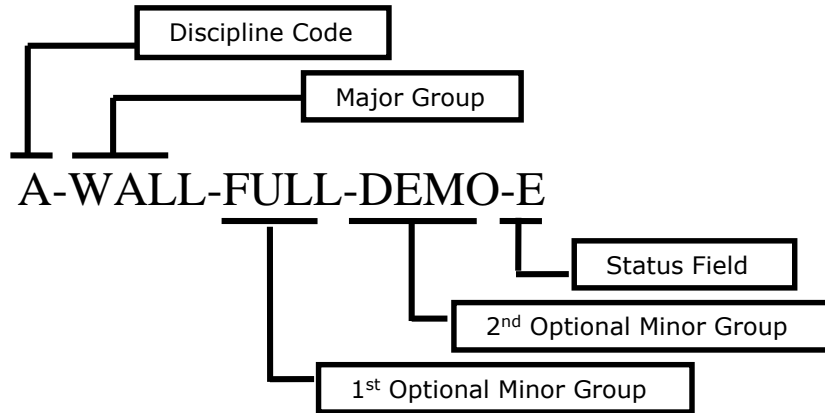

➤ Examples: Codes, Groups and Fields

• **Discipline Code**

A-_____	Architectural
E-_____	Electrical
F-_____	Fire Protection
M-_____	Mechanical
ETC.	

• **Major Group**

_-WALL-_____	Walls
_-DOOR-_____	Doors
_-LITE-_____	Lighting fixtures
_-COLS-_____	Columns
ETC.	

• **1st Optional Minor Group**

_____FULL-	Full height
_____DIMS-	Dimension
ETC.	

• **2nd Optional Minor Group**

_____IDEN-	Identification
_____PATT-	Pattern
ETC.	

• **Status Field**

_____N	New work
_____D	Demolition
_____T	Temporary work
_____F	Future work
ETC.	

## 4.27.12 File Structure

The DOT uses a specific folder structure for all digital submittals. (See Section 4.7.4)

## 4.27.13 Signing and Sealing

The Florida Department of Business and Professional Regulation (BPR) approved Architects to electronically sign and seal Plans and Specifications. Architects must use Digital Signature. See Chapter 5 for more information.

Helpful link: [Florida Statutes Part 1 ELECTRONIC SIGNATURES Chapters 668.001-668.006](#)

## 4.27.14 Submittal

As-Built Project CD shall include all files in the latest native version of CADD software the drawings were produced in along with a PDF set of prints and a complete set in AutoCAD DWG files.

Example: If the project CD was produced using Revit, the submittal will include all files in Revit RVT, AutoCAD DWG and a complete set of PDF files.

## 4.28 SPECIFICATION STANDARDS

Specifications must be prepared in accordance with Specifications Package Preparation Procedure (Topic Number 630-010-005) and the Specifications Handbook coordinated through the District Specifications Offices and available on the Specifications website:

<http://www.dot.state.fl.us/specificationsoffice/PackagePreparation/Default.shtm>

### 4.28.1 Standard File Names

For Digital Delivery Bid Sets, the Specification files are copied from the \specs\ sub-folder structure for delivery. Specification file naming convention for Digital Delivery submittals is: *fpid-SPECS[-].pdf*:

- **fpid** = full (11 digit) Financial Project Identification Number without dashes.
- **SPECS** = item description
- **[-]** = any additional naming specific to the project (optional)

Supplement file naming convention for submittals is: *fpid-SPECS-SUPP##[-].pdf*, where:

- **fpid** = full (11 digit) Financial Project Identification Number without dashes,
- **SPECS** = item description
- **SUPP** = Identifier
- **##** = sequential numbering of the supplements: 01, 02, 03, etcetera
- **[-]** = any additional naming specific to the project (optional)
- **BOE#** = Bases of Estimates – Pay Item number
- **TSP** = Technical Special Provision

<i>Original Delivery</i>	<i>Supplement1</i>	<i>Supplement2</i>
<i>fpid-SPECS[-].PDF</i>	<i>fpid-SPECS-SUPP01[-].PDF</i>	<i>fpid-SPECS-SUPP02[-].PDF</i>
<i>fpid-SPECS-TSP[BOE#] [-].PDF</i>	<i>fpid-SPECS-TSP[BOE#]-SUPP01[-].PDF</i>	<i>fpid-SPECS-TSP[BOE#]-SUPP02[-].PDF</i>

For Example: Begin with the *FPID* number, then the item description (SPECS), then supplement number (SUPP##), and finally any naming [-] specific to the project (optional).

This file naming convention allows project files to collate as sorted and combined in a single folder. Text, numbers and dashes are allowed. Characters that interfere with operating system path specifications or XML paths must be excluded, such as underline and spaces and (/ \ . : , < & # >).

### 4.28.2 Resource Files

Statewide implemented specifications files are distributed by the State Specifications Office through the District Specifications Offices.

### 4.28.3 Technical Special Provisions

When the use of a Technical Special Provision (TSP) is authorized by the District Specifications Office, the PDF of the TSP file(s) is individually signed and sealed and also becomes part of the overall project’s Specifications package.

For Digital Delivery, certificate based Digital Signature must be used.

The TSP must include the electronic statement incorporated on the TSP cover page. When a TSP is manually signed and sealed, it must be scanned in grey scale for seal visibility and no electronic statement is needed.

When TSPs are combined into the overall Specification package, the Signatory(s) of the TSPs do not have to re-sign the combined documents. Add the image of the seal to the cover page of each TSP. The individual files for each TSP must be digitally signed and sealed.

## 4.28.4 File Structure (Specs Only Projects)

- Specifications Folder Structure
- Supplemental Specifications Folder Structure
- Technical Special Provisions (TSP)\*

**Note** If a TSP is applicable to the project, then the folder for TSP(s) would apply to both the Project CD and Bid CD data set. Multiple TSP files may exist in the delivery.

The Specification Package is delivered as *fpid-SPECS.pdf*. Subsequent TSPs are delivered as *fpid-SPECS-TSP[BOE#].pdf* as shown in Chapter 5.8.

1. Create the project folder using all eleven digits of *fpid* Number. (i.e., 12345678900).
2. Inside the created (project) \FPID\ folder. This is where the Specifications package file (*fpid-SPECS[-].pdf*) is placed.
3. For Supplements, continue to use the ORIGINAL \FPID\ folder created in Step 1.
4. For Supplements. This is where the Supplement package file (*fpid-SPECS-SUPP##[-].pdf*) is placed.
5. Use digital signature to sign and seal the Supplement package file (*fpid-SPECS-SUPP##[-].pdf*).

**Note** **DO NOT** re-submit the entire Specification package for a Supplemental.

### **Example of a Specifications Only Package Folder Structure**

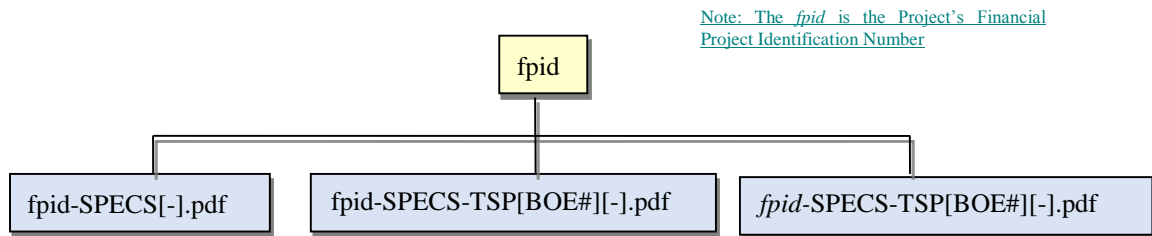

### **Example of a Supplemental Specifications Only Package Folder Structure**

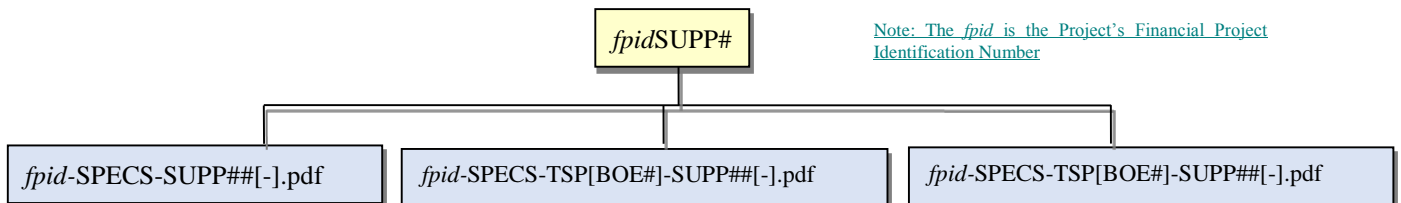

# Chapter 5

## DELIVERY PROCEDURE

### 5.1 PURPOSE

This chapter establishes the minimum requirements and functions necessary for Florida Department of Transportation (Department) CADD delivery, describing how electronic data is to be delivered and made available to customers.

### 5.2 SCOPE

This chapter covers the Department's functions to receive, authenticate, integrate, package, and distribute electronic project data including the CADD delivery.

### 5.3 DEFINITIONS

**3D Design:** The process of creating 3D Models for a project.

**3D Model:** A 3D model is a digital graphical representation of proposed facility/site data consisting of X, Y, and Z coordinates for producing objects in three dimensions to communicate design intent useful for visualization, analysis, animation, simulation, plans, specifications, estimates production, and life-cycle asset management. An accurately designed 3D model will be tied to a defined coordinate system.

**Authentication:** For Digital Signature, Authentication is the process where Digital Signatures are compared with identity data held by the issuer of a Digital Certificate (the Certificate Authority) to validate the identity of a Signatory; and that a document that has been signed with a Digital Signature has not been modified since signing. This is an automated process of the document software (such as with Adobe Reader or Acrobat) that provides feedback to the user that the file being examined is signed, the signatures are valid, and the document is unmodified since the Signatory signed it.

**Automated Machine Guidance (AMG):** Automated machine guidance is a process in which construction equipment is linked directly to the operation of machinery with a high level of precision, improving the speed and accuracy of construction processes. The AMG can utilize the GPS or robotic total stations for positioning information.

**Certificate Authority:** The 3<sup>rd</sup> party entity that issues the Digital Certificate to the professional signatory and who can validate the identity of the signatory.

**Compliance Certification Checklist Report:** A document that contains the data producers' written assurances that items required by the Department's Computer Aided Drafting and Design (CADD) Manual are included in the delivered project data and that certain Quality Control functions were performed.

**Composite PDF:** A document containing all of the plan sheet images composing the plans set in their index order. This document must be in Adobe Portable Document Format (PDF) format and reside in the project's root folder.

For an original delivery, this file is named *fpid-PLANS[-].PDF* (where *fpid* is the projects' Financial Project Identification Number and *[-]* is any additional naming specific to the project). The Composite PDF of the plans is signed and sealed with a certificate based Digital Signatures. Note that there may be more than one Composite PDF for a given set of plans, which would occur if the plans were subdivided for reasons such as file size or Signatory management.

During revisions, a second PDF is produced for the contractor named *fpid-PLANS-REV##[-].pdf*.

**Digital Certificate:** In cryptography, a digital certificate uses a digital signature to bind together a public key with an identity — information such as the name of a person or an organization, their address, and so forth. The certificate can be used to verify that a public key belongs to an individual. The signatures on a certificate are attestations by the certificate signer that the identity information and the public key belong together.

**Digital Terrain Model (DTM):** A DTM is a digital topographic model of the earth's surface minus objects such as trees, vegetation, and structures that can be manipulated through computer-aided design programs. All elements of the DTM are spatially related to one another in three dimensions.

The type of Digital Certificates used for the Department's design work must meet the Federal Government's Access Certificates for Electronic Services (ACES) program. The Department currently uses IdenTrust (<http://www.identrust.com/government/index.html>) to provide those digital certificates.

**Digital Delivery:** The contemporary method of project file delivery that relies upon the composite PDF(s) of the plans and specifications being produced and delivered, a ZIP archive of the CADD and engineering data for the contractor's use, and Digital Signature as the principal means to secure the composite PDFs of the plans and specifications files.

**Digital Signature:** Cryptographic data applied to an electronic file which is unique to the signatory, and is very difficult to forge. In addition, the digital signature assures that any changes made to the data or electronic file that has been signed cannot go undetected. A Digital Signature is much the same as a conventional handwritten signature that identifies a person signing the document. While traditional signatures are on paper, every digital signature stores information that will identify the person signing. There can also be information about changes made to a digitally signed document since the first signature was applied. In Digital Delivery, Digital Signatures are applied to Signature Sheet(s) in the plans or may be applied to documents that Professional(s) of Records are taking responsibility for.

**Project CD:** Media (CD, DVD, USB, etcetera) containing all data associated with a project. The contents must include the entirety of the Project Folder / Project Data Set.

**Revision:** Volume 1, Section 20.4 of the PPM defines a design revision as a modification to the PS&E Package/Bid Set after it has been accepted by Central Office Project Review.

**Revision Set:** The set of files that includes only the changed files from one revision to the next.

**Sheet:** A page in a multipage PDF (*fpid-PLANS[-].PDF* for an original delivery, or *fpid-PLANS-REV##[-].PDF* for revisions).

**Signatory:** The person or professional who secures files in a delivery using electronic cryptographic means such as Digital Signature. If the signatory is a professional, signatures will be governed by the rules defined by the Florida Boards of Professional Regulation. A professional may have multiple signatories for a project as needed by the revision process.

**Signature Appearance:** A graphical representation that appears on an electronic document indicating that a digital signature has been applied. As a minimum the appearance must contain the name of the signatory and a date-time stamp at the instant of signature. An appearance may contain a reason for the signature and/or a graphic image. The space provided for a reason is limited to a short sentence or phrase. More verbose language is better suited for text placed in the document near the appearance. Images vary from wet-ink signatures to professional seals. The use of a signature over a professional seal is discouraged as it facilitates forgery. The Signature Appearance is not proof of authenticity, only that a signature was applied. Authenticity is proven through the Validation process (see Validation definition).

**Signature Sheet(s):** The Digital Delivery process uses a Signature Sheet to define a professional's area of responsibility for those portions of the document being digitally signed. Signature Sheet(s), in the case of a plans set, is one or more sheets following a Key sheet which bears the digital signatures of the Professional(s) of Records.

The Signature Sheet is a convenient location for placing a digital signature appearance. By placing a digital signature on the signature sheet of a plans set, the Professional(s) of Record associates his/her professional signature with the entire plan set (for example: 61G15-23.004). Therefore notation must be provided on the signature sheet for a scope delineating the extent of the Professional's responsibility and an index of the specific sheets in the plan set for which the Professional is accepting responsibility (also 61G15-30.003 Minimum Requirements for Engineering Documents).

(See the Department's *Plans Preparation Manual* (PPM), Volume 2, Chapter 3 for examples.)

**Signing:** Acts of securing a file or set of files by means Digital Signature (see above definition).

**Signing and Sealing:** Digital Signature relies upon Public Key Infrastructure to embed secure data into a file the Signatory is signing, or signing and sealing. Any restriction upon the scope of responsibility, usability, or reliability of the file being signed must show with the appearance of the digital signature in that document.

**Sub-Consultant:** A consultant, separate from the primary consultant, who performs work for a project under the hire of a prime consultant.

**Sub-Delivery:** A delivery of files made by a sub consultant to a consultant, prime consultant or project manager, where that delivery is only a portion of the overall project.

**Surface:** A surface, in the context of 3D engineered models, represents an element of design such as existing ground, final grading, or pavement in three-dimensional workspace. All elements of the surface are spatially oriented to one another.

**Validation:** Validation is done in Digital Signature; however the validating application will compare hashes embedded cryptically within the file against ones calculated "on the fly" to see if a document has changed. The Validation extends to the hosting application verifying the identity of Signatory by using the Root Certificate to make contact with the Certificate Authority over the internet and checking identity records to ascertain the authenticity of the Signatory.

## 5.4 REFERENCES

[Construction Project Administration Manual \(CPAM\) Topic 700-000-000](#)

[Federal Highway Administration - 3D Modeling](#)

[Florida Permanent Reference Network \(FPRN\)](#)

[IdenTrust](#)

[LandXML](#)

[Plans Preparation Manual Volume 1 & 2, Topic Nos. 625-000-007/625-000-008](#)

[State Construction - Multiline](#)

## 5.5 RECEIPT AND ACCEPTANCE OF ELECTRONIC DATA

The Project Manager is responsible for ensuring that the terms of the scope of services of a project have been met, including the assurance that the Department's Quality Control requirements were fulfilled during production of the electronic data.

➤ **Receipt of Data**

The Project Manager must receive electronic data under a letter of transmittal.

➤ **Authentication**

Upon receipt of the delivery media, the Department will validate all Digitally Signed files.

➤ **Acceptance**

The Project Manager ensures that the delivery is checked for completeness and meets the terms, conditions and requirements outlined herein. Once the delivery has been determined to be compliant, a record of acceptance must be made.

## 5.6 ENGINEERING DATA SERVICES

Engineering Data Services is a *function (or functions)* within the Department for handling and re-distributing engineering and CADD data, including consolidation, packaging, archiving, and distribution of data belonging to a project.

➤ **Contract Packaging**

Engineering Data Services must coordinate regarding contract packaging requirements for a delivery for a letting found in the [Plans Preparation Manual Volume 1 & 2, Topic Nos. 625-000-007/625-000-008](#)

➤ **Archive and Security of Data**

Engineering Data Services must insure that prescribed safeguards for the data have been met and the archival package for data includes all electronic data available for a project. The data must be preserved where it can be retrieved at a future date meeting records retention standards set for such data.

## 5.7 PUBLICATION AND DISTRIBUTION

Engineering Data Services is responsible for publication and distribution of electronic data in accordance with procedures or requests, including but not limited to publishing electronic data to different media.

## 5.8 DIGITAL DELIVERY

Digital Signature is defined in *Florida Statutes 668.003* and uses a Digital Signature to secure files. Digital Signature is a "paperless" process that relies upon the intrinsic ability of the files themselves to encode cryptographic security features using a Digital Certificate issued to the Professional of Record.

The Digital Delivery comprises two parts:

- Part that represents the work product of design in the full project directory structure
- Part extracted from the full project directory structure that will be provided to contractors as defined in 5.8.1 below.



## 5.8.1 Production Deliverable Files

Some goals in providing the Engineering and CADD data to the contractor is to encourage the use of Automated Machine Guidance in Construction and to facilitate more accurate bidding. Other automation is also possible and BIM processes have demonstrated this automation in other industries. Advertising projects with both the CADD and Engineering Data is desired (i.e. LandXML of the project geometrics and surfaces).

**Note** Project design documentation (like pavement design report, typical section package, exceptions, variations, architectural calculations, drainage calculations, lighting design analysis report, permits, geotechnical reports, structural calculations, toll facility calculations, utility schedules, etcetera) will be delivered per PPM Volume1 Chapter 20. Some districts specify these documents be delivered under \admin\ or \calcs\ specific folders.

The Bid Set is made available to contractors for bidding during the advertisement period and generally includes:

- PDF files representing the Plans Set (Plans PDF)
- A PDF file containing the Specifications (Specs PDF)

A ZIP file (CADD ZIP) containing CADD and other project related files is useful to the contractor. The file naming convention for these files is intended to be descriptive, starting with more general information reading from the left of the name, and becoming more specific as one reads to the right. This allows the files to be sorted in order when viewed in Windows Explorer.

Only letters, numbers, dashes, and underscores characters are permitted in file names. Characters and spaces that interfere with operating system path specifications or XML interpretation such as: (/\ . : ; , < & # >”) must be avoided.

The following convention will be used when naming the Bid Set Files:

*<Fpid>-<FileDescription>-<PlansComponentCode>-<ComponentDescription>-<OptionalSheetRange>-<OptionalDescription>.PDF*

Example: 01234567890-PLANS-01-ROADWAY-23-27-DRAINAGE-STRUCTURES.PDF

- **FPID** - The files delivered for the Bid Set will always begin with the eleven digit Financial Project Identification (FPID) number followed by a dash as a separator. (Required)
- **FileDescription** - One of three terms (PLANS, SPECS, CADD) describing the contents of the file is added. (Required)

The PLANS portion of the delivery will often be made up of multiple PDF files. When there are multiple files making up the delivery for a particular type of data (PLANS, SPECS, and CADD), additional attributes will need to be included in the name.









- **PlansComponentCode** - Next a two digit code representing the order components are inserted into the plans set is added followed by a dash as a separator. (Required if divided by plans component)
- **ComponentDescription** - A text string describing the component is added followed by a dash as a separator. (Required if divided by plans component)

The Department's Standard Plans Component codes (corresponding to the component order defined in the PPM and the component description in parenthesis) are as follows:

- 01 – Roadway Plans (ROADWAY)
- 02 – Signing and Pavement Marking Plans (SIGNING)
- 03 – Signalization Plans (SIGNALIZATION)
- 04 – Intelligent Transportation System Plans (ITS)
- 05 – Lighting Plans (LIGHTING)
- 06 – Landscaping Plans (LANDSCAPE)
- 07 – Architectural Plans (ARCHITECTURAL)
- 08 – Structures Plans (STRUCTURES)
- 09 – Toll Facilities (TOLL)

- **OptionalSheetRange** - After the Plans Component Description, a dash is inserted as a separator, followed by the beginning sheet number in PDF, a dash, and the ending sheet number in the pdf. (Only required if a given plans component is further subdivided)
- **OptionalDescription** - Parent Drawing File Name of what is contained in the PDF.

The examples below shows how to follow this naming convention:

-  43328315201-PLANS-01-ROADWAY-1-22.pdf
-  43328315201-PLANS-01-ROADWAY-23-24-DRAINAGE\_STRUCTURES.pdf
-  43328315201-PLANS-01-ROADWAY-25-28.pdf
-  43328315201-PLANS-01-ROADWAY-COREBORING.pdf
-  43328315201-PLANS-01-ROADWAY-PNC.pdf
-  43328315201-PLANS-01-ROADWAY-VERIFIEDUTILITIES.pdf
-  43328315201-PLANS-02-SIGNINGMARKING.pdf
-  43328315201-PLANS-03-SIGNALIZATION.pdf
-  43328315201-PLANS-05-LIGHTING.pdf

<b>Digital Delivery Bid Set</b>	
<p><b><i>fpid-PLANS[-].PDF</i></b> – Composite PDF format file of all plan sheets, and delivered separate from the project folder structure. This file(s) is signed and sealed with Digital Signature.</p> <p><b><i>fpid-PLANS-REV##[-].PDF</i></b> – Revisions file(s) signed and sealed with Digital Signature.</p>	
<p><b><i>fpid-SPECS[-].PDF</i></b> – Specifications PDF format file delivered separate from the project folder structure. This file is signed and sealed with Digital Signature.</p> <p><b><i>fpid-SPECS-SUPP##[-].PDF</i></b> – Supplemental Specifications file signed and sealed with Digital Signature.</p> <p style="text-align: center;"><b>Note</b> Refer to Chapter 4.28, Specifications Standards - Technical Special Provisions (TSPs) in the Bid Set.</p>	
<p><b><i>fpid-CADD[-].ZIP</i></b> – An archive of the Project folder structure containing the CADD files (Native DGN's / DWG's of the platform used to design the project) and supporting data files from which the final plans were developed. This ZIP file is not signed and sealed and is delivered as a separate file outside of the project folder structure. The designer must determine which files should be included inside the <i>fpid-CADD[-].ZIP</i> file to support the plans and facilitate the contractor constructing the project. The folder structure inside <i>fpid-CADD[-].ZIP</i> closely resembles the Project Folder structure (as a sub-set), where files found in <i>fpid-CADD[-].ZIP</i> would be found at the same path as the project Folder structure.</p> <p>As a minimum, the <i>fpid-CADD[-].ZIP</i> should include:</p> <ul style="list-style-type: none"> <li>• CADD Drawing Files (.DGNs, .DWGs, etcetera)</li> <li>• Engineering Data Files (<i>described later in this chapter and prior chapters</i>)</li> <li>• Summary of Quantity Sheet Backup Drawings (<i>includes data such as, shapes and area identifications</i>)</li> <li>• 3D Deliverable Files (<i>a culling out of selected CADD and other files from the Project CD specifically for the contractor, described later</i>)</li> </ul> <p><b><i>fpid-CADD[-].ZIP</i></b> DOES NOT include the following files (and their variants):</p> <ul style="list-style-type: none"> <li>• <i>fpid-PLANS[-].PDF</i></li> <li>• <i>fpid-PLANS-REV##[-].PDF</i></li> <li>• <i>fpid-SPECS[-].PDF</i></li> <li>• <i>fpid-SPECS-SUPP##[-].PDF</i></li> </ul>	

**Note** Because *fpid-CADD[-].ZIP* does not represent the entire Digital Delivery, certain tools, such as *FileChecker*, should not be run against only the contents within *fpid-CADD[-].ZIP*. *FileChecker* should only be run against the full Project folder structure containing all of the Digital Delivery.

For Digital Delivery, the following table illustrates the file names used for successive revisions for the Bid Set:

<b>Original Delivery</b>	<b>Revision 1/ Supplement1</b>	<b>Revision 2/ Supplement1</b>
<i>fpid-CADD[-].ZIP</i>	<i>fpid-CADD-REV01[-].ZIP</i>	<i>fpid-CADD-REV02[-].ZIP</i>
<i>fpid-PLANS[-].PDF</i>	<i>fpid-PLANS-REV01[-].PDF</i>	<i>fpid-PLANS-REV02[-].PDF</i>
<i>fpid-SPECS[-].PDF</i>	<i>fpid-SPECS-SUPP01[-].PDF</i>	<i>fpid-SPECS-SUPP01[-].PDF</i>
<i>fpid-SPECS-TSP[BOE#][-].PDF</i>	<i>fpid-SPECS-TSP[BOE#]-SUPP01[-].PDF</i>	<i>fpid-SPECS-TSP[BOE#]-SUPP01[-].PDF</i>

For Example: The file names in the table below:

1. Begin with the Financial Project Identification Number (*fpid*) number, entering all 11 digits;
2. Then Item Description (i.e. PLANS, SPECS, ASBUILT, etcetera),
3. Then Revision or Supplement Number (REV## or SUPP##),
4. Finally any (*optional*) Naming Text following the dash [-] specific to additional details to assist in understanding the file's content.

➤ **Example File Names using the Digital Delivery naming convention:**

<b>Original Delivery</b>	<b>Revision 1/ Supplement1</b>	<b>Revision 2/ Supplement1</b>
12345678901-CADD.zip	12345678901-CADD-REV01.zip	12345678901-CADD-REV02.zip
12345678901-CADD-ConsultA.zip	12345678901-CADD-REV01-ConsultA.zip	12345678901-CADD-REV02-ConsultA.zip
12345678901-CADD-ConsultB.zip	12345678901-CADD-REV01-ConsultB.zip	12345678901-CADD-REV02-ConsultB.zip
12345678901-PLANS.pdf	12345678901-PLANS-REV01.pdf	12345678901-PLANS-REV02.pdf
12345678901-PLANS-01-ROADWAY.pdf	12345678901-PLANS-REV01-01-ROADWAY.pdf	12345678901-PLANS-REV02-01-ROADWAY.pdf
12345678901-PLANS-02-SIGNING.pdf	12345678901-PLANS-REV01-02-SIGNING.pdf	12345678901-PLANS-REV02-02-SIGNING.pdf
12345678901-SPECS.pdf	12345678901-SPECS-SUPP01.pdf	12345678901-SPECS-SUPP01.pdf
12345678901-SPECS-TSP560-A.pdf	12345678901-SPECS-TSP560-SUPP01-A.pdf	12345678901-SPECS-TSP560-SUPP01-A.pdf

➤ **Basic Delivery Examples:**

- Basic Delivery of Plans and Specs

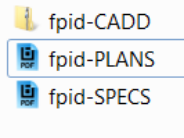

- Basic Delivery of Plans, Specs and Technical Special Provision

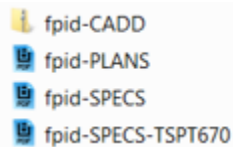

- Strung Project with Plans and Specs

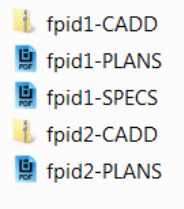

- Delivery with Plans Subdivided into Components

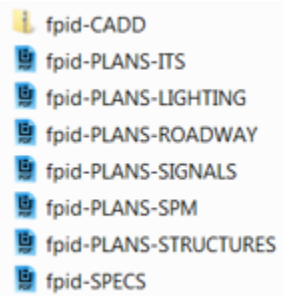

- Delivery of Plans Revision

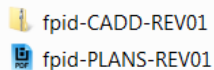

- Delivery of Plans and Supplement

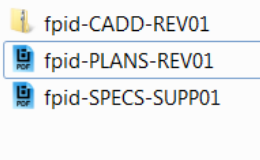

## 5.9 PRE-PRODUCTION

Pre-production activities involve the creation of a “seed” project to provide a framework for meeting the Department’s CADD standards and delivery requirements. Activities include the creation of the Project folder structure. The project must begin correctly so the Department’s standards for Delivery can be met.

The Department’s CADD Software Suite contains a tool to help create a Project folder structure with the appropriate project information. The newly generated Project folder structure and its content are referred to as the “seed project”.

For creating a “seed project” the *Create Project* application can be used to enter key financial, administrative and location data into the project as project identification information. This project identification information is contained in an XML file format (*ProjectID.xml*) stored in the `\_meta_info\` sub-folder of the project.

## 5.10 PRODUCTION

During the production phase, tasks are performed prior to the creation of the media for delivery of the data meeting the Department's delivery requirements. The Department provides several applications and resources to aid the user to meet the Department's specific requirements.

➤ **Tasks performed during the Production Phase include:**

- Follow the folder structure and file naming requirements for Delivery.
- Produce CADD design files to the Department's CADD Standards, using the workspaces and resources provided. Assemble any non-standard user created CADD resources, such as custom created cell libraries, in appropriate folders and document their use.
- Document all approved deviations from the Department's CADD Standards in the Project Journal file(s) including the documentation of important applications and methods used and decisions made during design. This is important for downstream users of the data to follow in the designer's footsteps.
- Create required Engineering Data and output files.
- Generate Quality Control (QC) Reports for all design files using the CADD QC tool provided. These reports indicate compliance to file naming and CADD element symbology standards.
- Merge any external project files into the project folder structure, including all files from sub-consultants, external reference files, scanned images for sheets (if any) and specifications documents.
- Bundle any non-standard graphics dependent resource files into the project sub-folders:
  - **\symb\** - to include user created fonts, shape files and/or line styles/linetypes
  - **\cell\** - to include project specific / user created cell or block libraries
- Check for any duplication of files and resolve. Remove non-essential file duplication. Remove non-essential "junk" files.
- Review the project for completeness, accuracy, and compliance with delivery standards. The application *FileChecker* is provided to help assist with this task.
- Create any files needed to support 3D modeling as required by the scope and to communicate design intention to the contractor.

### 5.10.1 *fpid*-PLANS.PDF File and Plans Component PDFs

Digital Delivery requires *fpid*-PLANS.PDF file(s) to be produced using a certificate based Digital Signature to secure the files by the Professional(s) of Record.

The *fpid*-PLANS.PDF will contain all of the sheets in the plan set in consecutive order, including signature sheet(s) located directly behind the key sheet. One digital signature will be applied to the signature sheet for each professional of record signing the *fpid*-PLANS.PDF file.

A Signature Sheet is required for all contract plans sets, even when there is only one Professional of Record. See the PPM Volume 2, Section 3.3.

When the plans set *fpid-PLANS.PDF* is subdivided into component PDF files, each Plans Component PDF will contain all of the sheets in that component set in consecutive order. Each Plans Component PDF will have its own key sheet and a signature sheet(s) located directly behind the key sheet. Subdivided plans component PDFs will have one of the applicable file names from the table below.

<i>fpid-PLANS-01-ROADWAY.PDF</i>
<i>fpid-PLANS-02-SIGNINGMARKING.PDF</i>
<i>fpid-PLANS-03-SIGNALIZATION.PDF</i>
<i>fpid-PLANS-04-ITS.PDF</i>
<i>fpid-PLANS-05-LIGHTING.PDF</i>
<i>fpid-PLANS-06-LANDSCAPE.PDF</i>
<i>fpid-PLANS-07-ARCHITECHTURAL.PDF</i>
<i>fpid-PLANS-08-STRUCTURES.PDF</i>
<i>fpid-PLANS-09-TOLLFACILITIES.PDF</i>

**Note** When the plan set is subdivided Plans Component PDFs, there will be no *fpid-PLANS.PDF*, since that name is reserved for a complete plans set.

If subdivided beyond the plans component level as described in Section 5.8.1, digital signature will need to appear on the Signature sheet of the subdivision, and the sheet must contain a listing of the Signatory's responsible sheets per PPM Volume 2, Section 3.3.

#### 5.10.1.1 Early Work Sheets of Plan Sets

Portions (certain early works sheets) of a plan set that are delivered early in the project development cycle may be digitally signed at the time of sheet development. In so doing, the professional of record will sign said early works sheets only once when those sheets were completed, unless subsequent changes are made to the sheets.

An example might be the Project Network Control (PNC) sheets; a Professional Surveyor & Mapper (PSM) may sign the PNC sheets once they are prepared, and deliver those sheets as a completed document. Other examples might include Soil Core Borings and Verified Utilities, which also happen early in the design and plans preparation process.

When a Plans Component PDF must be further subdivided and include early works as described above, the following table shows file name examples that may be used:

<i>fpid-PLANS-01-ROADWAY-PNC.PDF</i>
<i>fpid-PLANS-01-ROADWAY-COREBORINGS.PDF</i>
<i>fpid-PLANS-01-ROADWAY- VERIFIEDUTILITIES.PDF</i>

The distinction shows the intended Plans Component PDF that the early works sheets are intended to belong to, along with a keyword (PNC, COREBORINGS, etcetera) describing the content of the PDF delivered. In no case should this be construed to imply the delivery of random sheets signed by a single Signatory, or a collection of non-consecutive sheets in a single file by one Signatory. The plans producers must consider the user of the plans when making decisions about whether and how to subdivide a plans set. Subdivision should balance the needs of the plans producers and plans users. All sheets of a Plans Component PDF, or even the early works sheets described above, will be in consecutive sheet order and suitable for inclusion into the overall set.

- **Important Considerations When Producing the *fpid*-PLANS.PDF:**
  - For MicroStation, use the *Sheet Navigator* application to account for each design file containing sheets and that they are properly identified and tagged with sheet administrative data, unless the sheet source is external to MicroStation (i.e. a scanned file). Likewise, for AutoCAD Civil 3D, use the *Sheet Set Organizer (SSO)* to accomplish a similar function.
  - Use MicroStation *Print Organizer* (or equivalent), or AutoCAD Civil 3D *Sheet Set Organizer (SSO)* to create print image files of the plan sheets and print files. Both may be used to help batch print sheets to PDF files.
  - File size of the PDF files being produced must be considered. The larger the PDF files, the more difficult they are to manage, particularly if they have to be transmitted over the Internet (as during advertisement) or used on a mobile device like a tablet in the field.
  - Produce *fpid*-PLANS[-].PDF in Black and White or Grayscale, unless color is required. Production of the PDF in color enlarges the file size considerably. All plans sheets must be produced in the PDF in the same reading orientation, preferably Landscape, with the title block displaying at the bottom of the sheet.
  
- **Additional Digital Delivery Tasks During the Production Phase:**
  - Create *fpid*-PLANS[-].PDF(s) for the original delivery, and *fpid*-PLANS-REV##[-].PDF(s) for subsequent revisions.
  - Use certificate based Digital Signature to sign and seal plans, specifications, and any other relevant reports or data. If XML data is to be signed, such as a LandXML, the Department delivers a tool called *FDOT XML Signer* to do so. (Refer to the Department's Office of Information Technology list of approved certificate authorities.)
  - Make certain the Engineering Data is produced and included in the *fpid*-CADD.ZIP (see later in this Chapter).
  - Files and data must be manually put together to create the Bid Set.

**Note** For strung projects, each "Lead" and "Goes-with" Project dataset and Bid Set data is delivered separately. Each "lead" and "Goes-with" will have its own *fpid*-PLANS[-].PDF, *fpid*-CADD.ZIP, etcetera.

## 5.10.2 Engineering Data

In addition to the delivery of the files produced during the course of development, the Department requires the inclusion of certain Engineering Data files for critical geometrics in the design. These can include the alignments, profiles, cross sections, and surfaces. Critical roadway geometric items, such as the centerlines and profiles of the proposed mainline, side streets, special ditches, and utilities, must be included.



### 5.10.2.1 Delivery Standards for Engineering Data

The required formats for Engineering Data files for a project as part of the Delivery includes LandXML, which covers basic geometry element types, and is readable by the Department's software systems, from both Bentley and Autodesk. In addition, LandXML may be consumed by many software used by the highway construction industry including AGTEK, Trimble, Carlson, and others.

The LandXML format defines data exchange format for basic roadway geometrics including:

Point data	Profiles
Curve data	Pipe Networks
Spiral data	Terrain Model Surfaces
Alignments (with station equations)	Survey Data.
Cross Sections (surface and design sections)	

**Note** LandXML is also widely supported by many civil engineering software. Read more about LandXML at: <http://www.LandXML.org>

### 5.10.2.2 Cross Sections

Although LandXML defines a specification for the exchange of cross section data, the Department has legacy systems (*FDOT Multiline*) used in certain offices. Therefore, for GEOPAK designed projects, the designer must create and deliver cross sections in a text file format called Multi-line GEN. This format includes surface definitions such as existing ground terrain, and bottom of the proposed template, to define materials set forth in the Department's Design Standards Indexes 500 and 505. For Civil 3D projects, a detailed materials report for cross sections must be provided.

**Note** Users are strongly encouraged to reference the *MultiLine* application on the State Construction Office website at: [State Construction Office Downloads](#).

### 5.10.2.3 Quantity Files

Engineering Data supporting Quantity calculations must be delivered according to the guidelines and formats defined by the *Construction Project Administration Manual (CPAM) Topic 700-000-000* found at: <http://www.dot.state.fl.us/construction/manuals/cpam/CPAMManual.shtm>

## 5.10.3 3D Deliverables - Data for Machine Control in Construction

3D Design and modeling is intended to facilitate Automated Machine Guidance (AMG) in construction. Both Bentley and Autodesk provide 3D Design tools and have been augmented through the Department's workspaces for the Department's projects and help support exporting data usable in AMG processes. AMG technology can reduce time and cost of construction because of greater productivity by equipment operators, fewer grade checks are needed, greener construction (less fuel and equipment wear), greater safety, less rework, and less survey staking required. Contractors invest in AMG for safety, productivity, and to stay competitive.

The benefits of 3D Design and AMG are well documented on the Federal Highway Administration web pages here: <http://www.fhwa.dot.gov/construction/3d/>

In general, projects characterized by the following are the best candidates for modeling and AMG:

- Projects with large amounts of earthwork or paving, including new road construction or significant reconstruction. Resurfacing and RRR projects involving variable cross slope and superelevation correction are also good candidates. When scoping projects, preliminary design and planning should question why 3D Design should not be used, rather than if it should. As a matter of guidance, the designer should consider that if controlled cross sections are going to be needed in the plans to communicate design intent to the contractor, then the project is a good candidate for 3D modeling.
- Projects with a good GPS environment for receiving satellite signals, or enough line of sight for using total station and laser controlled systems. The Department's Florida Permanent Reference Network (FPRN) provides statewide GPS coverage:

<http://www.dot.state.fl.us/surveingandmapping/FPRN.shtm>

- Projects with designs that are based on accurate existing ground Digital Terrain Models (DTM).

3D Design workflow must start at the beginning of the project and create the needed data from survey, and is contingent upon data being tied to an AMG field usable coordinate system. The Department requires projects to be performed on the State Plane coordinate system, and the vertical datum is referenced at time of survey activities. After design, the overall reduction of construction costs by modeling and AMG should be realized. For design, the 3D workflow enables the project development team to visualize potential impacts and promote intense collaboration during the planning and design process. Discovering design errors by inspection of the 3D models will reduce costly change orders during construction.

The use of modeling will eventually require conversion of CADD data and other model data to AMG formats. This conversion is the responsibility of the contractor, as the contractor may have special needs that the designer may not anticipate. However the formats of data delivered as prescribed by this Manual should enable successful translation by the contractor.

The electronic files delivered with the contract documents are provided as a courtesy to the contractor. The Department's Contracts Administration Office releases this CADD data with accompanying exculpatory language stating the contractor cannot use the data as a basis for claims. Contractors will be completely responsible for any data conversions or information derived from model data provided by designer. Post-design services may employ a designer to convert model data to needed AMG formats, or refine the models to meet contractor specific needs. Since the intention of the Department is to encourage 3D modeling and AMG in construction, requirements for accountability and certification of 3D models will also be forthcoming.

#### 5.10.3.1 Types of Modeling Data Needed

##### ➤ Control

The survey control for the design of the project needs to be clearly transmitted to the contractor, including the coordinate system and datum of that control. This is important because the contractor must calibrate his AMG equipment to that control upon which the design model is tied. The State Surveying and Mapping Office provides instructions for establishment and densification of field survey control, and the State Construction Office's Proposed Specification: **0050700 Control of the Work** has further guidance for AMG operations.

##### ➤ Alignments/PGLs

As described in Section 5.10.2, LandXML file(s) of the controlling alignments and profiles that represent the controlling geometrics of the project will be delivered and can be extracted from other CADD files delivered. These tie all other data provided directly to the contract plans set. The data must be in the coordinate system of the control that can resolve to the field and be in harmony with all the other data that will be provided.

➤ **Surfaces**

Surfaces created by survey can represent existing conditions and those created during design using CADD software indicate the designer's intent. Surfaces representing existing conditions at the time of the survey used for design (the pre-design existing (Ground) surface), as well as the finished construction (Top) surface are delivered. LandXML Triangular Irregular Network (TIN) surfaces would typically be delivered for most projects and the same surfaces also delivered as 3D design files in their native CADD systems. Surfaces represented by LandXML files can become unwieldy for larger projects (surfaces should be represented in LandXML files of less than 500 MB per surface-file), so it may be necessary to subdivide a project's surface data into logical sections when delivering large LandXML surface files.

For Example: A relatively small TIN surface (i.e. 32,208 points, 63,462 triangles) can be represented as a LandXML file of approximately 5 MB. So a LandXML surface file of approximately 100 times this data content (about 3 million points) could be manageable as LandXML. Since LandXML is text-based, it will also compress significantly when creating a ZIP to deliver the data (for example, a 50 Megabyte LandXML file of a TIN surface will ZIP down to approximately 10 Megabytes for delivery).

Surfaces delivered in MicroStation DGN or AutoCAD DWG 3D design formats (meeting the Department's CADD standards for symbology) are most usable when each surface is separated into their own drawing files. Points and Break lines should be contained in the surface files.

**Note** If the native to CADD system used to produce those surfaces mentioned above also stores surface data in alternative formats, as such the case with GEOPAK: i.e. a .TIN, a GEOPAK .DAT, or an InROADS / GEOPAK Roadway Modeler .DTM, then those files must also be delivered.

Surfaces may also be needed in more common formats used in software by the contracting industry. Contractors have communicated a preference for AutoCAD 3D design formats (3D DWG and 3D DXF) which are exportable by both MicroStation and AutoCAD tools. Some contractors have also communicated the need for finished top surfaces to be "smoother" and be represented differently than in TIN formats. These finished surfaces can sometimes be exported in alternate 3D representations called "mesh," "grid," or "lattice" surfaces depending upon which design platform is used.

➤ **Break Lines**

Hard surface breaks must be respected during construction (i.e. edges of pavement, shoulder breaks, etcetera) and need to be provided to enhance the surface data. These aid the field AMG equipment operator during grading and string-less staking operations by preventing the "shaving" that could occur as the equipment transitions the break.

➤ **Denigrating Geometry**

When finishing drawings, 2D & 3D controlling geometry is to be represented by basic vector geometry types such as lines, arcs, and polylines. This Geometry should not be combined into Blocks or Cells which destroys any attached original design intelligence.

**5.10.3.2 3D Deliverables Supporting AMG for 3D Designed Projects**

The following table describes the file(s) to be provided for construction. Contractors have requested the Department isolate the CADD and LandXML files they would typically need with a consistent name scheme. These files are usually copies of files already produced in the ordinary course of 3D Design CADD work, copied to a convenient folder location ( \3DDeliverables\ ) for the contractor's usage. The Department provides a tool called *Create3DDeliverables* to aid designers when copying / renaming original files to these replicas for the contractor.

<b>3D DELIVERABLES SUPPORTING AMG for 3D PROJECTS</b>	
<b>File Name</b> <i>(put in \3DDeliverables\)</i>	<b>Description</b>
<b>Design Alignments and Profiles</b>	
AMG-ALGN##.xml	All Alignments and Profiles extracted from the \Roadway\ALGNRD, PROF or model files and \Roadway\DSGNRD or CORRRD files in LandXML format.
<b>2D Proposed Planimetrics Design</b>	
AMG-2DSGN##.dwg/dgn	2D proposed Roadway design extracted from the \Roadway\DSGNRD file. (Production of this file for construction is at the designer's discretion.)
AMG-2DRPR##.dwg/dgn	2D proposed Drainage design extracted from the \Roadway\DRPRRD file. (Production of this file for construction is at the designer's discretion.)
AMG-2PDPL##.dwg/dgn	2D proposed Pond design extracted from the \Roadway\PDPLRD file. (Production of this file for construction is at the designer's discretion.)
<b>2D Existing Survey</b> <i>(Note: These are being considered to merge into a single survey Planimetrics file)</i>	
AMG-2TOPO##.dwg/dgn	2D proposed existing Topography extracted from the \Survey\TOPORD file. (Production of this file for construction is at the designer's discretion.)
AMG-2DREX##.dwg/dgn	2D proposed existing Drainage extracted from the \Survey\DREXRD file. (Production of this file for construction is at the designer's discretion.)
AMG-2UTEX##.dwg/dgn	2D proposed existing Utilities extracted from the \Survey\UTEXRD file. (Production of this file for construction is at the designer's discretion.)
<b>3D Existing Survey Surfaces</b>	
AMG-3SURFACEEX##.xml	3D existing terrain surface to be exported from the \Survey\GDTMRD file as LandXML format. (Production of this file for construction is at the designer's discretion. This file will be produced if the 3D Existing Surface dwg/dgn file(s) are not produced.)
AMG-3SURFACEEX##.dwg/dgn	3D existing terrain surface to be exported from the \Survey\GDTMRD file. (Production of this file for construction is at the designer's discretion. This file will be produced if the 3D Existing Surface LandXML file(s) are not produced.)
<b>3D Proposed Surfaces</b>	
AMG-3SURFACEPR##.xml	3D proposed finished (top) surface to be exported as LandXML format from the \Roadway\AMGMRD file. (Production of his file for construction is at the designer's discretion. This file will be produced if the 3D Proposed Break line(s) dwg/dgn file is not produced.)
<b>3D Proposed Break Lines</b>	
AMG-3DSGN##.dwg/dgn	3D proposed Roadway design extracted from the \Roadway\DSGNRD file. (Production of this file for construction is at the designer's discretion. This file will be produced if the 3D Proposed Surface(s) LandXML file(s) is not produced. Geometric elements should be in vector.)

**Note** All LandXML .xml files must use the LandXML 1.2 schema published at <http://www.LandXML.org>

### 5.10.3.3 Maximum Corridor Frequency Interval Spacing for 3D Design

Design software used by the Department samples the 3D corridor models at user defined intervals in order to create surfaces. To ensure reasonable fidelity in surface models for AMG operations, maximum sampling intervals are described below:

**Note** The designer may choose to sample more frequently to more accurately represent his design model, although there is a limiting return (larger files and poorer computer performance) if sampling too frequently. Designers must balance these competing consequences when deciding appropriate sampling frequency for their projects.

Facility	Design Speed < 45 MPH	Design Speed > 45 MPH
Rural Sections	maximum corridor interval	
Tangents	20 feet	20 feet
Curves	10 feet	10 feet
Intersections	5 feet	5 feet
Urban Sections	maximum corridor interval	
Tangents	10 feet	20 feet
Curves	5 feet	10 feet
Intersections	2 feet	5 feet

Additional sampling intervals will normally be needed at critical regions in horizontal geometry stations (i.e. PC's, PT's), superelevation transition locations, and at profile geometry critical locations (i.e. PVC's, PVT's, and profile high/low points). The designer must also add sampling at other critical regions along the corridor, such as changes of typical section, critical drainage locations, approach and interior to intersections, and median crossovers.

**5.10.3.4** Quality Control of Corridor Models and Extracted Surface

3D Design for roadways is intended to produce output of a corridor model from which surfaces may be derived. It is incumbent upon the designer to verify these corridor and surface models representing their design intent so the resulting models and data derived from them can be relied upon. The previous Section describes maximum sampling intervals for developing corridor models based upon facility and design speed; however more frequent sampling may be required to achieve the desired accuracy or resolution of the 3D model.

There are several methods that can be used to check the “quality” of the proposed models and surfaces, and many checks rely upon visualization techniques on the data. These can include:

- Visual inspection through examining the models/surfaces using 3D perspective views and orbits. The Z (elevation) can sometimes be exaggerated during these operations to show discontinuity in the surfaces where problems might lie.
- Visual Inspection through examining the models/surfaces using drive through and fly through view manipulations and animations. Other simulation techniques can be employed also.
- Contouring the surface models and examining the resulting contours.
- Surface display by means of rendered/stylized surfaces (and solids). In some software these views can be thematically colored and or shaded, indicating slope or elevation change.
- Cross Section and Profile extraction - Do these extractions corroborate the contract plans? Equally, are plan sections and profiles contemporary with the model?
- “Rain Drop” analysis to see where water distributed over a surface would flow or accumulate if the surface were treated as if it were impervious and perfectly smooth.
- Representing elements in either wire-frame or as solid bodies, where they can be examined for conflict or “interference” relative to neighboring or crossing elements.
- Use of temporary dimensioning and labels to test the models elements for appropriate length, elevation, slope, etcetera.
- Design criteria can also be checked for critical design standards such as sight distance, K-value, rate of curvature, cross slope, and curve widening criteria.

**Note** Visualization can be embellished with applications of various rendering materials, lighting, and shading.

## 5.10.4 Merging External Project Files

Files must be merged into the main Project folder structure prior to the project delivery. These include CADD system dependency files, and files provided from outside sources, such as those produced by sub-consultants.

### 5.10.4.1 CADD System Dependency Files:

Certain CADD references might reside external to the project folder during the production phase. Before delivery to the Department, these files must be placed in the appropriate locations within the Project folder structure. It is strongly recommended that these files be included in the Project folder structure early on in project development and verified that referencing functions work properly.

**Note** Reference files must also be attached without the “save full path” option, and should be located by their relative paths from the root of the Project folder.

For printing purposes, any user created custom line style/linetype, font resource, and cell / block library files used for the project must be included with the project in the sub-folder \symb\. In addition, any external design files that are referenced, such as sheet border files, must be copied to the project folder. This allows the view or recreation of prints matching the original delivery for future customers of the data.

**Note** The designer does not need to include the Department's standard CADD resources delivered in the Department's CADD Software (either MicroStation or AutoCAD resources). However, the Department's CADD Software version information must be provided in the Project Journal.

### 5.10.4.2 Files from Outside Sources:

Files that come from an outside source include files produced by a sub-consultant. Files from sub-consultants must be delivered to the primary consultant, or the Department's designer, following the same requirements for Delivery.

### 5.10.4.3 Merging Previously Digitally Signed Documents:

Once a document is signed using a digital certificate, the document is valid when it is completely unaltered. Merging two or more documents together, even if those documents are signed and completely valid independently, produce a completely new document - thus an altered document. When merging previously signed documents, the PDF editing software will strip off all digital signatures that have been applied.

In situations where it is necessary to merge previously digitally signed documents, retain the original signed documents from which the merged document is produced. If it is necessary for the merged document to be signed, then it must be signed by the original signatories or their successors.

## 5.10.5 Reviewing the Project

A basic Compliance Certification Checklist Report is found in Section 5.10.9 may be employed to help the data producer consider critical items in their QC review for delivery. The Department's CADD Software Suite provides tools (including *QC Inspector* and *FileChecker*) to help ensure quality control which helps enable a successful review. One must use due diligence to make sure all delivery requirements are met.

**Note** Some of the Department's Districts may have their own supplemental checklists. Contact your District Project Manager for additional District specific supplemental delivery requirements.

➤ **Example: Some items to review would include:**

- Take particular care to look for missing sheets, gaps in the sheet numbering, duplicate sheet numbering, etcetera. Check for misspellings in sheet borders and other grammatical errors.
- Take particular care to find multiple files in the Project folder structure with the same file name, but different content, which must be resolved. Likewise, find files with the same content, but different filenames (which could occur as with the case of the files beginning with "AMG..." as described previously).
- Make certain the Professional of Record Note appears on plan sheets indicating the source of the official record.
- Ascertain whether the *fpid*-PLANS[-].PDF(s) contains all sheets, in a properly indexed order, and is scaled and rotated properly.
- Validate the digital signatures of signed files.
- Confirm that the Project Journal(s) are complete and accurate.

The Department's tools mentioned should be used to find and resolve potential issues, but they are only tools to aid the producer in their Delivery. It is the responsibility of the producer to perform a thorough review. This procedure does not prescribe every potential item that might need to be checked.

## 5.10.6 Sign and Seal Project Files

Digital Delivery uses Digital Signature for documents and complies with *Florida Administrative Code* governing the specific discipline for the professional signing those documents.

Regulated transactions, such as the development and submission of engineering plans, specifications, reports, and surveys, require high assurance when signing documents. When documents are distributed electronically it is important that recipients can:

- Verify document authenticity - confirming the identity of each person signing the document
- Verify document integrity - confirming that the document has not been altered

Certificate-based signatures provide both of these security services. The Department chose to use certificate-based digital signature infrastructure using third party certificate authorities to provide independent identity validation. Once certificate-based digital IDs are acquired by professional Signatories, PDF software can be used to sign PDF files and validate files received from others. In addition, the Department provides a tool, *XML Signer*, to digitally sign any XML based file with a Digital Certificate. Likewise, any applications that support Digital Signature with public key infrastructure can be used to sign their respective files.

Digital Signature allows one to:

➤ **Sign Documents:**

- Sign PDF files using certificate IDs
- Place a signature box anywhere on the appropriate page or sheet
- Add multiple signatures to a document or page
- Add a time stamp to the document
- Certify a document with a visible (or hidden) signature to enable recipients to verify authenticity with or without seeing a visible signature on the currently viewed page
- Automatically embed certificate data to support long-term validation

➤ **Validate Documents:**

- Validate all signatures, confirming the identity of everyone signing the document
- Validate document integrity by tracking all previously signed versions of a document to verify changes made during the document's lifecycle

➤ **Set Privileges and Permissions for Others:**

- Certify a document while leaving portions available for form filling, additional signatures, or comments
- Lock a PDF document with a Certificate ID to restrict editing or copying

**5.10.6.1 Digital Certificates**

An Access Certificate for Electronics Services (ACES) digital certificate is used to ensure identity, authenticity and accountability in citizen-to-government, business-to-government, and government-to-government electronic transactions. An ACES digital certificate is an electronic identity issued by a Certification Authority that establishes an individual's identity per the Federal Government Services Administration (GSA) standards when using electronic transactions. There are several 3rd party Certificate Authorities that issue ACES certificates. The Department internally uses ACES certificates issued by IdenTrust: <http://www.identrust.com/fdot/index.html>. The Department's Office of Information Technology (OIT) has recently adopted additional Certificate Authorities found here:

<http://www.dot.state.fl.us/OIS/ApprovedDigitalCertificateAuthorities.shtm>

When applying Digital Signatures, many software applications allow the signature to have an "appearance." As a minimum, use an appearance with the text name of the Signatory and the date-time stamp at the instant of signing. (See PPM Volume 2, Section 3.3)

- ❖ Do not include any additional watermark or overlay.
- ❖ Do not include an image of the "wet ink" signature of the Signatory (a violation of Board rules).
- ❖ Do not include company logos, or other images within the Digital Signature appearance.

The reason (text) for signing may be placed in a text block within the drawing where more space is available. The image of an impression seal may also be included, but is not part of the Digital Signature itself. For the Department's Plans are provided with the CADD Software Suite that contain images of seals and may be found in the *Seals.cel* or *Seals.dwg* Cell / Block Library(s).

**5.10.6.2 Managing Digital Certificates**

ACES Digital Certificates uniquely identify an individual. As such, these certificates must be closely guarded against unauthorized usage. Digital Certificates used for signing and sealing must be "Under the sole control of the person using it", as stated in Florida Administrative Code 61G15-23.004 and others. Install certificates using "High" security options and disallow exportation of certificates from the primary Professional of Record (POR) workstation. The POR may not "delegate" the use of a digital certificate by sharing a certificate, sharing a password, or otherwise compromising sole possession and use of the certificate.

**5.10.6.3 Multiple Signature Sheets**

In situations where there are multiple signatories for a plan set where there are too many to list on a single signature sheet, multiple signature sheets may be added to the plan set. All signature sheets for a given component must be placed successively after the component Key Sheet.

Please refer to the Department's **PPM, Volume 2 Section 3.3** for examples: <http://www.dot.state.fl.us/rddesign/PPMManual/2016/Volume2/V2Chap03.pdf>

**Note** Finished sheets digitally signed and sealed must bear the Professional of Record Note as shown in the Department's **PPM** Exhibits. The note must be applied before signing and sealing and final delivery.

**5.10.6.4 Securing the Project for Delivery**

Digitally signed documents have the security key information embedded in the files themselves. Digitally signed files are secured and authenticated using commercially available software (Adobe, Bluebeam, and etcetera).



## 5.10.7 Legacy Electronic Signature Projects

Provenance and uninterrupted legal record of the project data must occur, whether it be by product or management practice. Therefore it is important that both the data producer and the Department make a sensible effort to ensure the documents supporting the digital signing and sealing of files by a professional signatory and the securing of the delivery be preserved in a manner consistent with those responsibilities under the rules of the Boards of Professional Regulation in Florida.

For projects that were once performed under the old Electronic Delivery process, the Department will maintain the paper copies of PEDDS Signature and Manifest documents until it is determined how these records may be preserved in other media that meets the requirements of the Florida Boards of Professional Regulation.

## 5.10.8 Media Requirements for Delivery

All electronic projects submitted to the Department must be on write protected physical media (CD-ROM or DVD-ROM) unless otherwise approved by the Department's District PS&E Manager or Program Management Administrator. Use only 1<sup>st</sup> Class archival quality writable media.

If the project is too large to fit on one CD/DVD, then the process for delivery to the Department's must be reviewed with the Department's Project Manager before splitting the project on multiple CD/DVDs or choosing an alternate media. If approved by the appropriate authority other means of transmission of data, such as File Transfer Protocol (ftp) or File Transfer Appliance (FTA) may be used.

- **All Physical Project Media Must have a Project Identification Label with the Following:**
- Financial Project ID Number of Project
  - Project Description (*including County and State Road numbers, local road designation*)
  - Firm or District Performing the Work
  - Name of the Department and Consultant Project Manager(s)
  - Creation Date of the Media
  - Disk (#) of (Total #) (*if multiple ROMs are needed*)
  - Delivery Type Label (*Project CD, Bid CD, etcetera*)
  - Anticipated Letting Date for the Project

With the increase of storage capacity and more cost efficiency of USB removable memory drives (thumb drives), use of this media will grow in popularity for the Department's Deliveries.

**If memory drives are used:**

- *The physical drive must be labeled with the Project Identification (fpid) number and District as a minimum.*
- ❖ A text file must be included on the media's root folder (not Project folder) containing the Project Identification label information and Transmittal Letter containing the same.

## 5.10.9 Compliance Certification Checklist Report

All Department Project deliveries must be provided to the Department's Project Manager, unless an alternate agreement is reached, along with a Compliance Certification Checklist Report (or similar document).

**Note** Department's Districts may use a more comprehensive form in their QA process than the following example. The Department prefers this or similar documentation of QC compliance be submitted digitally and included in the \admin\ or \data\ project sub-folders.

All electronic data submittals are to be transmitted to the Department's Project Manager. At a minimum, the following questions must be addressed before submittal, and this or a similar checklist given to the Project Manager along with the submittal.

1. Have Project Journal(s) been created containing all necessary project information?
2. Is the listing of the software packages and versions used to create all delivered files included in the journal?
3. Are all the native files generated by the CADD/Design software in checklist item 2 included in the delivery package?
4. Are design files compliant with the Department's CADD Standards for folder structure, file naming, and element symbology?
5. Does the submittal include all user-created CADD System resource files (line styles/linetypes, fonts, etcetera) that may have been used with the project?
6. Has the QC software been run against the design files? Are the resultant QC Reports of compliance included in the delivery submittal? Has FileChecker been run to verify folder structure, file naming standard, etcetera?
7. Have the prescribed engineering data files been created and submitted for the control, alignments, profiles, and surfaces in the formats? Is this information stored in the appropriate directories?
8. Where Multi-line (GEN) general file format files created and included for the surfaces representing the cross sections? Have LandXML files of the critical geometrics and surfaces been produced and delivered?
9. Have images for the plans been checked and included for all sheets in the plan set? PDF format? Checked for sheet size, scale, and rotation/orientation?
10. Are the files representing the plans, referenced by the Department's Plans Preparation Manual, Chapter 19 signed and sealed? Is the Electronic Plan Note on each sheet?
11. Has Digital Signature been applied to the correct files signed with the appropriate Digital Certificate and independently validated?
12. Has the final media for submission been properly labeled and re-checked to make sure the data is readable and can be authenticated?
13. For projects that were scoped for 3D Design deliverables, have the 3D surface models (Ground and Top) been delivered in the formats prescribed?

**FPID:**

**Date of Scope:**

**Certified by EOR:**

## 5.11 POST-PRODUCTION

The “Post-Production” involves the review and acceptance of a Delivery and making that Delivery available to the Department’s internal services for posting. Functions include: receipt and authentication of delivery media and placement of project data into systems for general.

Upon receipt of the secured Delivery package and the accompanying documents, the Compliance Certification Checklist Report(s) must also be reviewed for completion and the signed files must be opened and authenticated.

**Note** Following the requirements within this Manual does not guarantee an acceptable work product, as this procedure does not address the quality of the engineering or survey work performed.

Once the Delivery is accepted, the electronic project will be imported into the Department’s file management systems for subsequent use. Copies of the submittal media will be distributed among various stakeholders, such as Construction and Maintenance.

## 5.12 REVISIONS

Revisions to the Department’s projects require the files that have changed since the previous delivery. The designer must deliver:

- ❖ Ensure the Department has a complete copy of the original Delivery:
  - *fpid-CADD[-].ZIP, fpid-PLANS[-].PDF*
  - *fpid-SPECS[-].PDF*
  - *fpid-SPECS-TSP[BOE#][-].PDF*
- ❖ The Revision: (The Bid Set must only contain the changed files in the revision/supplement.)
  - *fpid-CADD-REV01[-].ZIP*
  - *fpid-PLANS-REV01[-].PDF*
  - *fpid-SPECS-SUPP01[-].PDF*
  - *fpid-SPECS-TSP[BOE#]-SUPP01[-].PDF.*
- ❖ The complete Project folder structure with all contemporary files included.

## 5.13 STRUNG PROJECTS

Digital Delivery requires that each “Lead” and “Goes-with” project to be delivered as separate datasets under their own *fpid*, and never combined or intermingled in their respective project folder structures.

Regarding delivery of the bid sets for the strung project, the folder containing the bid sets for the Lead project and Goes-with projects will be named the FPID of the lead project and must include the suffix “ETC”.

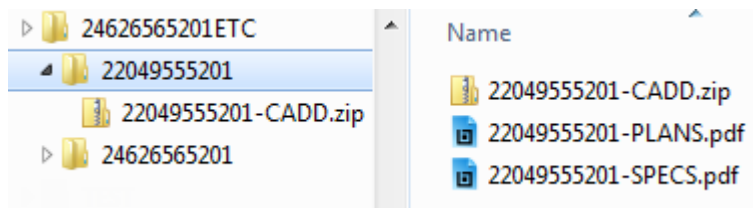

## **5.14 RE-LET PROJECTS AND ROLL BACK REVISIONS**

In rare cases, the Department must Re-Let a project. If no revisions have occurred to the project set for Re-Letting, the Department will simply re-advertise and Let the project with the submitted Project CD or Bid Set CD data. However, if a revision has been applied to the project set for Re-Letting, then the revision is no longer relevant. The Re-Let project is essentially an original letting all over again. In this case, the data producer may be asked to Roll Back the revision indexing as if the Delivery were an original Delivery. This could involve updating the plan sheets to remove the revision enumerations. The changes to plans that were once identified as a revision are now considered simply a plan change.

## **5.15 DESIGN BUILD PROJECTS**

The Scope of Services between the designer and contractor defines the deliverables to one another. If either party is bound by agreement to make a delivery of data to the Department, then the guidance for Digital Delivery should be applied.

# Chapter 6

## SUPPORT

### 6.1 PURPOSE

This chapter establishes the primary components of Florida Department of Transportation (Department) Computer Aided Design and Drafting (CADD) support structure and services, including the statewide training, and defines the applications and tools supported by the Engineering / CADD Systems Office (ECSO).

### 6.2 SCOPE

This procedure establishes the hierarchy of CADD-related support roles and responsibilities from the peer level to the statewide level of the ECSO, the District CADD support function, and the Technical Advisory Committees (TAC).

### 6.3 REFERENCES

The Department's CADD *Customer Support Guide*:

<http://www.dot.state.fl.us/ecso/downloads/publications/CADDSupportGuide/CADDSupport.shtm>

### 6.4 COMPONENTS OF CADD SUPPORT

The Department supports a core group of CADD software products for in-house production as specified herein. Consultant support is generally limited to the Department developed CADD software modules, interfaces, and configurations. The statewide support is coordinated through the ECSO. A list of the current versions of the supported products, with some accompanying technical documentation, is available from the ECSO website:

<http://www.dot.state.fl.us/ecso/main/Version/CurrentVersions.shtm>

Most of the core CADD software products are commercial programs that the Department has purchased a license to use. Note that the Department makes no warranty, expressed or implied, as to the documentation, functionality or performance of these or other Department developed programs described herein.

The primary components of CADD Support structure include: Systems Support, Operational Support, and Training.

#### 6.4.1 Systems Support

ECSO manages and coordinates the testing, selection, procurement, and maintenance of CADD applications.

#### 6.4.2 Operational Support

ECSO manages and coordinates the development, enhancement and support of the CADD software applications used by the engineering community to perform the Department's CADD production.

### 6.4.3 Training

ECSO manages and coordinates the provision of CADD technical materials and education to assist in maintaining user proficiency.

Systems Support, Operational Support, and Training is also coordinated with assistance from the district CADD Managers and/or OIT personnel assigned to support CADD.

## 6.5 HIERARCHY OF CADD SUPPORT

The CADD statewide support structure provides for the handling of support at different levels for each of the support components. Users must seek support at the lowest level before escalating a support request to the next level.

The Department's CADD *Customer Support Guide* also outlines the escalating hierarchical support structure and provides detailed product information for the user to access support and assistance for each. The *Customer Support Guide* can be downloaded from the ECSO Publication website:

<http://www.dot.state.fl.us/ecso/downloads/publications/CADDSupportGuide/CADDSupport.shtm>

### 6.5.1 Systems Support

➤ **First Level:**

- The First Level of Systems Support is the District staff. The District CADD IT contact or CADD Manager is the primary liaison with Central Office for addressing CADD systems issues. District CADD systems support activities involving the CADD Manager and/or OIT personnel include the following: Assist with identifying the users' hardware and software needs.
- Distribute and setup equipment and CADD software.
- Provide input for the statewide procurement.
- Provide day-to-day technical support of the computer hardware and CADD software systems used in the District.

➤ **Second Level:**

- The Second Level of Systems Support is the OIT staff. The OIT support responsibilities include the following: Manage the budget for procurement of CADD hardware.
- Procure CADD hardware and maintenance.
- Provide inventory management associated with the statewide CADD hardware.
- Provide as-needed technical support of the hardware.

## 6.5.2 Operational Support

➤ **First Level:**

The First Level of Operational Support is *Peer Support*.

➤ **Second Level:**

The Second Level of Operational Support is through the *Technical Advisory Committee (TAC) Members Support*, who represents the districts and disciplines on task teams to communicate and resolve support issues of statewide interest.

➤ **Third Level:**

The Third Level of Operational Support is the *District Support Staff*, including, but not limited to, CADD Managers, CADD IT contacts, and engineering services personnel. These support personnel, collectively, are responsible for supporting the core CADD software products for each respective district.

➤ **Fourth Level:**

The Fourth Level of Operational Support is the *ECISO Support Staff*. The ECISO is responsible for the Department's application development, enhancements, and support. ECISO will provide support assistance or will procure required services as necessary, coordinating support requests, including those to CADD software vendors.

## 6.5.3 Training Support

ECISO manages and coordinates the statewide CADD training program for the Department's personnel. The CADD training program may encompass the core CADD Software and CADD production procedures.

The District CADD Managers, District and Unit Training Coordinators, and/or OIT personnel assigned to support CADD are responsible for respective District CADD training coordination.

[THIS PAGE INTENTIONALLY LEFT BLANK]



# Chapter 7

## SOFTWARE DEVELOPMENT AND DISTRIBUTION

### 7.1 PURPOSE

This chapter establishes how Florida Department of Transportation (Department) Computer Aided Design and Drafting (CADD) software is developed, tested, approved and distributed.

### 7.2 SCOPE

This chapter applies to all of the Department's supported CADD Software products procured or developed to produce the Department's projects and covers the steps used to develop, test, approve and distribute these CADD Software products. This CADD Software is the responsibility of the Engineering / CADD Systems Office (ECSO) and other designated offices.

### 7.3 DEFINITIONS

**Alpha Testing:** Initial testing of CADD software products or enhancements by the development staff and testing by the support staff outside of the development environment.

**Beta Testing:** Secondary testing of CADD software products performed in a production-like environment by end-users.

**Beta Testing Coordinator:** An individual responsible for facilitating the beta testing of CADD software.

### 7.4 DEVELOPMENT

Development encompasses new CADD software applications, enhancements to existing CADD software (added features), and the maintenance releases (bug fixes) of CADD software. Development is based upon needs identification and may include the purchase of commercial software when appropriate.

CADD software needs are communicated to the ECSO by user requests or by Technical Advisory Committee(s) (TACs). The ECSO also identifies needs based upon experiences with CADD support activities and the evolution of trends in the CADD software industry.

Development request specifications compiled by ECSO may be coordinated with the appropriate TAC(s), CADD Managers and OIT personnel assigned to support CADD.

#### 7.4.1 Development or Acquisition

The Statewide CADD Coordinator will decide whether to develop CADD software in-house, contract for development services, or purchase a CADD software commodity. The ECSO will keep the user community informed as to procurement status (including training and implementation schedules) of major CADD development projects of statewide interest.

## 7.5 SOFTWARE UPDATES

The Department's Computer Aided Design and Drafting (CADD) Software is upgraded periodically and as needed to issue enhancements and fixes. Updates occur for major releases (generally released when major upgrades to platform CADD software by our vendors becomes available), or when major upgrades to the Department's design standards are implemented. Interim Maintenance Releases and Hot fixes (released as required) are available for download from the ECSO internet website. Notification of new releases and updates are posted on the ECSO website, via the Department's *Contact Mailer* application, during training sessions, and notified through other venues as appropriate.

The Department supports both PowerGEOPAK (or MicroStation and GEOPAK Suite) and Autodesk's AutoCAD Civil 3D as the standard roadway design platforms. Regardless whether Bentley's or Autodesk's design software is used, efforts are made to maintain similar standards and deliverables so the resulting product is consistent, predictable, and repeatable (CPR).

## 7.6 SOFTWARE TESTING

ECSO, or the designated office, performs alpha testing of CADD software products during software development as required. Beta testing is to be performed prior to the general release of CADD software. The ECSO will track the progress of Beta testing.

When alpha testing demonstrates CADD software is believed to be in working order for the features intended, the software will be beta tested by end users prior to release. The "beta testing coordinator," from the ECSO or the designated office, will facilitate these activities.

The beta testing by any of the Department's disciplines must only be initialized following review and approval by either the CADD Manager or CADD IT contacts.

The request for approval to proceed with beta testing, based on the appropriate recommendation, will be initialized by ECSO.

Each major CADD Application has a primary support contact assigned by the ECSO. This person, or their delegate, may also serve as the Beta Testing Coordinator.

## 7.7 TAC REVIEW AND RECOMMENDATION

ECSO may coordinate with the TACs seeking recommendation for distribution and production use after conclusion of Beta testing.

## 7.8 CADD PRODUCT APPROVAL AND DISTRIBUTION

Major CADD Software releases are approved by ECSO and notification to the Technology Services and Support Managers are made using the Software Distribution Notification Application (SDNA). ECSO may also use other means of notification for CADD Managers, CADD IT Contacts and Consultants.

The CADD Managers and/or CADD IT Contacts are responsible for distributing the approved software for production use to the end users. External distribution will be at the discretion of ECSO.

In most cases, users are expected to operate the most contemporary version of the Department's CADD Software release on Department projects, unless otherwise exempted by either the project's Scope of Services or a written exemption by the Department's Project Manager.

Consultants can acquire the Department's CADD Software, fixes and upgrades from the ECSO internet website: <http://www.dot.state.fl.us/ecso/downloads/software/software.shtm>

## 7.9 MINIMUM SYSTEM REQUIREMENTS

The current Department's CADD Software was developed and tested for the Department's standard workstation configurations. This standard configuration is published in the *Adopted Information Technology Resource Standards* and is available from the Department's Office of Information Technology (OIT) intranet website.

The Department's CADD Software is listed on ECSO Current Version website:

<http://www.dot.state.fl.us/ecso/main/Version/CurrentVersions.shtm>.

Other software configurations may operate with the Department's CADD Software. Use and support of the Department's CADD Software on other configurations are the sole responsibility of the user.

## 7.10 TRANSLATION OF FILES

The Department requires MicroStation .DGN format (V8 and higher) or AutoCAD .DWG format (2014 or higher) for the delivery of all design files, except as specifically defined in subsequent *CADD Manual* chapters for specific disciplines.

The data producer is solely responsible for any translation required for delivery to the Department. The accuracy of translation of the design files and adherence to the standards and specifications contained herein, including the validity of the geometric elements, is the sole responsibility of the person performing the translation.

[THIS PAGE INTENTIONALLY LEFT BLANK]

# Chapter 8

## QUALITY ASSURANCE

### 8.1 PURPOSE

This chapter establishes the basis for Quality Assurance (QA) monitoring of the Florida Department of Transportation (Department) District Computer Aided Design and Drafting (CADD) functions, including the areas of responsibility, frequency of monitoring and reporting methods.

Offices under the direction of the Department's Chief Engineer are responsible for determining the critical QA requirements for their functional areas and develop plans to monitor those requirements. The Engineering/CADD Systems Office (ECSO) defines the critical Quality requirements for deliverables in this Manual. These include standard file formats and components for data delivery, adherence to a standard Project folder structure, file naming conventions and CADD Standards for electronic files. ECSO also establishes a QA monitoring plan for CADD to facilitate compliance with these deliverable requirements.

### 8.2 AUTHORITY

*Section 20.23(3), Florida Statutes (F.S.)* states that the Department must ensure quality and monitor implementation of policies and procedures.

*Quality Assurance and Quality Control Policy, Topic No. 001-260-001* states that it is the policy of the Department to use a systematic but flexible approach to Quality Assurance (QA) and Quality Control (QC) to monitor work processes to implement laws, rules, procedures, policies and standards. This is intended to ensure compliance and quality performance by the Central Office and District units responsible for the delivery of transportation products, services and information.

### 8.3 SCOPE

Each central office function has the responsibility of monitoring the implementation of policies, procedures and standards established for their respective processes. This Manual applies to all CADD functions and will be monitored.

### 8.4 REFERENCES

Section 20.23(3), Florida Statutes (F.S.)

[http://www.leg.state.fl.us/STATUTES/index.cfm?App\\_mode=Display\\_Statute&Search\\_String=&URL=0000-0099/0020/Sections/0020.23.html](http://www.leg.state.fl.us/STATUTES/index.cfm?App_mode=Display_Statute&Search_String=&URL=0000-0099/0020/Sections/0020.23.html)

Quality Assurance and Quality Control Policy, Topic No. 001-260-001

<http://fdotwp1.dot.state.fl.us/ProceduresInformationManagementSystemInternet/FormsAndProcedures/ViewDocument?topicNum=001-260-001>

## 8.5 DEFINITIONS

**Critical Area:** Those steps in the CADD process where significant problems may be introduced unless the production criteria and standards are followed.

**Critical Requirement:** A decision, standard or process operation that will substantially and negatively affect the quality of the product or results if omitted or not performed to the expected level.

**Compliance Indicator:** Evidence that the critical requirements which are being applied are producing the desired result.

**Monitoring Plan:** A QA work plan for CADD developed with District input that identifies what, where, when and how monitoring, reporting, tracking and follow up are to be performed.

**Quality Assurance (QA):** The planned, coordinated and continued activities performed to measure processes against predetermined critical requirements.

**Quality Control (QC):** The planned, integrated activities performed during work processes to ensure completeness, accuracy, proper decision making, and conformance with all other valid requirements.

**Quality Control (QC) Reports:** Reports that must be included with the final project delivery, including the Compliance Certification Checklist Report and all reports listed therein. Some reports are produced by software within the Department's CADD Software Suite.

## 8.6 QA MONITORING PLAN

The QA Monitoring Plan identifies the critical areas of CADD to be monitored, critical requirements and the criteria to measure process compliance. Compliance indicators will be used by the ECSO to determine how well the process is performing.

The monitoring plan provides the method for monitoring CADD processes, the frequency of team visits, the method for reporting and sharing monitored results with the districts, and the method for tracking and eliminating non-compliance issues.

The plan covers the major delivery requirements in this Manual, but users are reminded that quality CADD production is the result of performing many individual CADD activities correctly and in accordance with the current criteria and standards.

The *CADD Quality Assurance Monitoring Plan* is published on the Department's SharePoint per Department policy.

## 8.7 ACCOUNTABILITY

Production units must follow the procedures for preparing plans and maps. Each district must establish quality compliance indicators for all projects and monitor performance and compliance using those indicators. Consultants are agents of the Department and are responsible for the quality of projects they prepare. They must comply with the Department's *CADD Manual* and must perform QC activities to ensure the completeness and accuracy of services performed for the Department.

## 8.8 QUALITY ASSURANCE (QA) REVIEWS

CADD QA Reviews will be conducted per Department requirements. The ECSO will report the results of these reviews to the District Secretary. Measuring compliance with the critical requirements as outlined in the *CADD Quality Assurance Monitoring Plan* will be the purpose of these reviews.

## 8.9 QUALITY CONTROL (QC) – DATA PRODUCERS’ ROLE

Each district must maintain an established review process to determine and report the quality and compliance levels of project data. Each district is also responsible for having a management plan for quality control of the Delivery with the expectation that quality control plans comply with this Manual.

The Department provides tools to help ensure the creation of a standard Project folder structure, standard file names and the standard level symbology for all design files. The Department provides QC software to check a design file’s adherence to the Department’s level-symbology standards at any time during the production phase of the project. Tools are listed below:

- **FileChecker** – Provides reporting for certain portions of the Delivery compliance with standards and business rules.
- **QC Software** – The *QC Inspector* contains tools used to check, correct and report the compliancy of elements within any design file against the Department’s CADD Standards. All checking and reporting is performed in real time and the results recorded into reporting documents that are saved to the current active project.

## 8.10 QUALITY ASSURANCE (QA) – CENTRAL OFFICE ROLE

The CADD Quality Assurance Reviews (QAR) is to monitor the districts’ individual QC Plans. QA also encourages continuous improvement through sharing both ideas and improved technology advances.

Districts will be expected to ensure that their own Process Management Plan is in place for Delivery and that projects comply with that process.

The QAR of the Districts’ will be conducted periodically following the CADD QA monitoring plan. Reports are distributed to the District Secretaries and other affected offices.

## Appendix A – CADD Standard Rule Tables

<i>ALGNRD - Alignment Design</i> .....	1
<i>AUTOSP - AutoTURN</i> .....	3
<i>CLIPRD - Clip Border</i> .....	5
<i>DRDTRD - Drainage Detail</i> .....	7
<i>DREXRD - Existing Drainage</i> .....	12
<i>DRMPRD - Drainage Map</i> .....	13
<i>DRPRRD - Drainage Proposed</i> .....	18
<i>DRXSRD - Drainage Cross Section</i> .....	22
<i>DSGNLD - Landscaping Design</i> .....	28
<i>DSGNLT - Lighting Design</i> .....	30
<i>DSGNRD - Roadway Design</i> .....	33
<i>DSGNSG - Signalization Design</i> .....	44
<i>DSGNSP - Signing and Pavement Marking Design</i> .....	50
<i>DTMRD - Digital Terrain (Proposed)</i> .....	54
<i>GDTMRD - Digital Terrain (Existing)</i> .....	56
<i>GEOTECH - Geotechnical</i> .....	56
<i>GSWKSP - GuidSIGN</i> .....	58
<i>IRRGLD - Irrigation</i> .....	61
<i>ITSSP - Intelligent Transportation System</i> .....	62
<i>KEYSHT - Key Sheets</i> .....	69
<i>MSARSP - Mast Arm Details</i> .....	72
<i>OPEN - All Levels and Symbology Accepted</i> .....	75
<i>PDXSRD - Pond Cross Section</i> .....	75
<i>PLANRD - Roadway Plan Sheet</i> .....	82
<i>PLPRRD - Roadway Plan/Profile Sheet</i> .....	85
<i>QTDSRD - Quantity Computation</i> .....	89
<i>RDXSRD - Roadway Cross Section</i> .....	95
<i>RDXSSP - Signing and Pavement Cross Section</i> .....	101
<i>RWDTRD - Right of Way Detail for Roadway</i> .....	110
<i>RWENG10 - Right of Way</i> .....	112
<i>SPST10 - Structures</i> .....	117
<i>SURVRD - Survey Development Model</i> .....	122
<i>TCDSRD - Traffic Control</i> .....	130
<i>TOPORD - Existing Topography for Roadway</i> .....	138
<i>TYPDRD - Typical Section Data</i> .....	141
<i>UTADRD - Utilities Adjustment</i> .....	150
<i>UTEXRD - Utilities Existing</i> .....	158
<i>UTPRRD - Utilities Proposed</i> .....	162



[THIS PAGE INTENTIONALLY LEFT BLANK]

## ALGNRD - Alignment Design

Critical	Rule	Level Name	Level Description	ByLevel Color	ByLevelStyle / Linetype	ByLevel Weight
	algnrd	ActivePointCell_dp	Active Point Cell	4	0 / Continuous	10
	algnrd	AdhocPoint_dp	Adhoc Points Placed by SheetInfo	0	4 / DGN4	0
	algnrd	BaselineSurvey	Baseline Survey	0	0 / Continuous	2
	algnrd	CLConst_dp	Center Line of Construction	0	0 / Continuous	2
	algnrd	ClipBorder_dp	CLIP Border and Civil 3D View Frame	3	0 / Continuous	0
	algnrd	ClipDrawingBound_dp	CLIP Drawing Boundary	3	3 / DGN3	0
	algnrd	COGO_dp	COGO Information	3	0 / Continuous	1
	algnrd	ConstLines	Construction Lines and References	1	0 / Continuous	0
	algnrd	ConstLines_pm	Construction Lines	4	0 / Continuous	0
	algnrd	CurveData_dp	Curve and Coordinate Data Elements Including PC, PT, PI Symbols	4	0 / Continuous	2
	algnrd	CurveDataLabel_dp	Curve Data Labels PC,PI, PT	0	0 / Continuous	2
	algnrd	DimLines_dp	Dimension Lines, Corresponding Terminators, Equation Lines	0	0 / Continuous	1
X	algnrd	EaseLicLine	Easement License Agreement Line	5	6 / DGN6	0
	algnrd	GridMaj_dp	Grid Lines Major in Profile and Cross Section	3	0 / Continuous	1
	algnrd	GridMin_dp	Grid Lines Minor in Profile and Cross Section	0	0 / Continuous	0
	algnrd	GridMinSub_dp	Grid Lines Minor Sub on Cross Section Sheets	20	0 / Continuous	0
	algnrd	ImageAttachment_dp	Image Attachments	0	0 / Continuous	0
	algnrd	LeaderLine_dp	Leader Line and Terminator with Text	0	0 / Continuous	1
	algnrd	Logo_dp	Consultant Engineer of Record Logo	0	0 / Continuous	1
	algnrd	MatchLines_dp	Match Lines with Text, Arrows for Station Notations	1	0 / Continuous	2
	algnrd	Miscellaneous0	Undefined Proposed Item - Color Blue Weight 0	1	0 / Continuous	0
	algnrd	Miscellaneous1	Undefined Proposed Item - Color Blue Weight 1	1	0 / Continuous	1
	algnrd	Miscellaneous2	Undefined Proposed Item - Color Blue Weight 2	1	0 / Continuous	2
	algnrd	Miscellaneous3	Undefined Proposed Item - Color Green Weight 0	2	0 / Continuous	0
	algnrd	Miscellaneous4	Undefined Proposed Item - Color Green Weight 1	2	0 / Continuous	1
	algnrd	Miscellaneous5	Undefined Proposed Item - Color Green Weight 2	2	0 / Continuous	2
	algnrd	Miscellaneous6	Undefined Proposed Item - Color Red Weight 0	3	0 / Continuous	0
	algnrd	Miscellaneous7	Undefined Proposed Item - Color Red Weight 1	3	0 / Continuous	1
	algnrd	Miscellaneous8	Undefined Proposed Item - Color Red Weight 2	3	0 / Continuous	2
	algnrd	Miscellaneous9	Undefined Proposed Item - Color Red Weight 3	3	0 / Continuous	3
	algnrd	NonPlottingEle_dp	Non-Plotting Items - Construction Elements, Type 66 Elements, Etc.	4	0 / Continuous	0
	algnrd	NorthArw_dp	North Arrows	0	0 / Continuous	2
	algnrd	PayItem_dp	Pay Item Number Label Elements	4	0 / Continuous	2
X	algnrd	PlotBorder_dp	Plot Border	3	0 / Continuous	0
	algnrd	ReferencePt_dp	Survey and Construction Reference Point Details and Elements	4	0 / Continuous	2
	algnrd	RoadwayMisc	Roadway Items (Miscellaneous)	4	0 / Continuous	2
	algnrd	Scale_dp	Bar Scale, Scale Label Elements	0	0 / Continuous	2
	algnrd	Scratch1_dp	Scratch Level for Temporary or Informational Items	4	0 / Continuous	0
	algnrd	Scratch2_dp	Scratch Level for Temporary or Informational Items	5	0 / Continuous	0
	algnrd	ScratchEle_dp	Scratch Level for Draft Elements, Temporary Elements, Etc. (DO NOT PLOT)	3	0 / Continuous	0
	algnrd	ScratchEle2_dp	Scratch Level for Draft Elements, Temporary Elements, Etc. (DO NOT PLOT)	4	0 / Continuous	0

Critical	Rule	Level Name	Level Description	ByLevel Color	ByLevelStyle / Linetype	ByLevel Weight
	algnrd	SheetBorder_dp	Sheet Border	1	0 / Continuous	4
	algnrd	SheetLines_dp	Sheet Lines	1	0 / Continuous	2
	algnrd	SheetLinesMisc1_dp	Sheet Lines	1	0 / Continuous	0
	algnrd	SheetLinesMisc2_dp	Sheet Lines	2	0 / Continuous	2
	algnrd	SheetLinesMisc3_dp	Sheet Lines	3	0 / Continuous	2
	algnrd	SheetLinesMisc4_dp	Sheet Lines	4	0 / Continuous	2
	algnrd	SpecialDetails	Special Details	6	0 / Continuous	1
	algnrd	StationTicL_dp	Station Tic Marks (Large) and Text	0	0 / Continuous	2
	algnrd	StationTicS_dp	Station Tic Marks (Small) and Text	0	0 / Continuous	2
	algnrd	SumBoxBorder_dp	Summary Boxes Borders	4	0 / Continuous	3
	algnrd	SumBoxLines_dp	Summary Boxes Lines and Miscellaneous Items	4	0 / Continuous	1
	algnrd	SumBoxLinesMin_dp	Summary Boxes Lines Minor Line and Miscellaneous Items	4	0 / Continuous	0
	algnrd	Tables_dp	Data Tables and All Autodesk Tables	0	0 / Continuous	1
	algnrd	TextBLStation	Text - B/L Station and Tics	0	0 / Continuous	2
	algnrd	TextConstEle	Text - Construction Element	0	0 / Continuous	1
	algnrd	TextCurveData	Text - Curve Data Note	0	0 / Continuous	2
	algnrd	TextDetails	Text - Detail Notes	4	0 / Continuous	2
	algnrd	TextLabel	Text - Label	0	0 / Continuous	2
	algnrd	TextLandscape	Text - Landscape Labels	0	0 / Continuous	1
	algnrd	TextMajor	Text - Major	0	0 / Continuous	5
	algnrd	TextMinor	Text - Minor	0	0 / Continuous	0
	algnrd	TextMisc	Text - Miscellaneous	0	0 / Continuous	1
	algnrd	TextNotes	Text - Notes	4	0 / Continuous	1
	algnrd	TextProfLabel	Text - Profile, Horizontal and Vertical Axis Labels	0	0 / Continuous	2
	algnrd	TextProjLabel	Text - Begin and End Project Label with Leader Lines	1	0 / Continuous	2
	algnrd	TextShtNo	Text - Sheet Number	0	0 / Continuous	2
	algnrd	TextTables	Text - Key Sheet Indexes and Table Data	4	0 / Continuous	2
	algnrd	TextTitle	Text - Title	0	0 / Continuous	3
	algnrd	TextXSElev	Text - Cross Section Elevations	2	0 / Continuous	1
	algnrd	Viewport	Viewport (For AutoCAD Use)	3	0 / Continuous	0
	algnrd	Xreference01_dp	Reference Files (For AutoCAD Use)	0	0 / Continuous	1
	algnrd	Xreference02_dp	Reference Files (For AutoCAD Use)	0	0 / Continuous	1
	algnrd	Xreference03_dp	Reference Files (For AutoCAD Use)	0	0 / Continuous	1
	algnrd	Xreference04_dp	Reference Files (For AutoCAD Use)	0	0 / Continuous	1
	algnrd	XSCell	GEOPAK Cross Section Cell/Block and Profile Cell/Block	8	0 / Continuous	1

## AUTOSP - AutoTURN

Critical	Rule	Level Name	Level Description	ByLevel Color	ByLevelStyle / Linetype	ByLevel Weight
	autosp	ActivePointCell_dp	Active Point Cell	4	0 / Continuous	10
	autosp	AdhocPoint_dp	Adhoc Points Placed by SheetInfo	0	4 / DGN4	0
	autosp	ATDims	AutoTurn Profile Dimensions, Tire Envelope	1	0 / Continuous	1
	autosp	ATTText	AutoTurn Profile and TT Dimensions, Annotation, TT Overhang	0	0 / Continuous	1
	autosp	ATVHP	AutoTurn Temporary Profile for Building Custom Type	1	0 / Continuous	1
	autosp	COGO_dp	COGO Information	3	0 / Continuous	1
	autosp	ConstLines	Construction Lines and References	1	0 / Continuous	0
	autosp	ConstLines_pm	Construction Lines	4	0 / Continuous	0
	autosp	DimLines_dp	Dimension Lines, Corresponding Terminators, Equation Lines	0	0 / Continuous	1
X	autosp	EaseLicLine	Easement License Agreement Line	5	6 / DGN6	0
	autosp	GridMaj_dp	Grid Lines Major in Profile and Cross Section	3	0 / Continuous	1
	autosp	GridMin_dp	Grid Lines Minor in Profile and Cross Section	0	0 / Continuous	0
	autosp	GridMinSub_dp	Grid Lines Minor Sub on Cross Section Sheets	20	0 / Continuous	0
	autosp	ImageAttachment_dp	Image Attachments	0	0 / Continuous	0
	autosp	LeaderLine_dp	Leader Line and Terminator with Text	0	0 / Continuous	1
	autosp	Logo_dp	Consultant Engineer of Record Logo	0	0 / Continuous	1
	autosp	MatchLines_dp	Match Lines with Text, Arrows for Station Notations	1	0 / Continuous	2
	autosp	Miscellaneous0	Undefined Proposed Item - Color Blue Weight 0	1	0 / Continuous	0
	autosp	Miscellaneous1	Undefined Proposed Item - Color Blue Weight 1	1	0 / Continuous	1
	autosp	Miscellaneous2	Undefined Proposed Item - Color Blue Weight 2	1	0 / Continuous	2
	autosp	Miscellaneous3	Undefined Proposed Item - Color Green Weight 0	2	0 / Continuous	0
	autosp	Miscellaneous4	Undefined Proposed Item - Color Green Weight 1	2	0 / Continuous	1
	autosp	Miscellaneous5	Undefined Proposed Item - Color Green Weight 2	2	0 / Continuous	2
	autosp	Miscellaneous6	Undefined Proposed Item - Color Red Weight 0	3	0 / Continuous	0
	autosp	Miscellaneous7	Undefined Proposed Item - Color Red Weight 1	3	0 / Continuous	1
	autosp	Miscellaneous8	Undefined Proposed Item - Color Red Weight 2	3	0 / Continuous	2
	autosp	Miscellaneous9	Undefined Proposed Item - Color Red Weight 3	3	0 / Continuous	3
	autosp	NonPlottingEle_dp	Non-Plotting Items - Construction Elements, Type 66 Elements, Etc.	4	0 / Continuous	0
	autosp	PayItem_dp	Pay Item Number Label Elements	4	0 / Continuous	2
X	autosp	PlotBorder_dp	Plot Border	3	0 / Continuous	0
	autosp	PointLocator_ep	Point Locator Symbol (Existing)	4	0 / Continuous	0
	autosp	ReferencePt_dp	Survey and Construction Reference Point Details and Elements	4	0 / Continuous	2
	autosp	RoadwayMisc	Roadway Items (Miscellaneous)	4	0 / Continuous	2
	autosp	Scratch1_dp	Scratch Level for Temporary or Informational Items	4	0 / Continuous	0
	autosp	Scratch2_dp	Scratch Level for Temporary or Informational Items	5	0 / Continuous	0
	autosp	ScratchEle_dp	Scratch Level for Draft Elements, Temporary Elements, Etc. (DO NOT PLOT)	3	0 / Continuous	0
	autosp	ScratchEle2_dp	Scratch Level for Draft Elements, Temporary Elements, Etc. (DO NOT PLOT)	4	0 / Continuous	0
	autosp	SheetBorder_dp	Sheet Border	1	0 / Continuous	4
	autosp	SheetLines_dp	Sheet Lines	1	0 / Continuous	2
	autosp	SheetLinesMisc1_dp	Sheet Lines	1	0 / Continuous	0

Critical	Rule	Level Name	Level Description	ByLevel Color	ByLevelStyle / Linetype	ByLevel Weight
	autosp	SheetLinesMisc2_dp	Sheet Lines	2	0 / Continuous	2
	autosp	SheetLinesMisc3_dp	Sheet Lines	3	0 / Continuous	2
	autosp	SheetLinesMisc4_dp	Sheet Lines	4	0 / Continuous	2
	autosp	SpecialDetails	Special Details	6	0 / Continuous	1
	autosp	SumBoxBorder_dp	Summary Boxes Borders	4	0 / Continuous	3
	autosp	SumBoxLines_dp	Summary Boxes Lines and Miscellaneous Items	4	0 / Continuous	1
	autosp	SumBoxLinesMin_dp	Summary Boxes Lines Minor Line and Miscellaneous Items	4	0 / Continuous	0
	autosp	Tables_dp	Data Tables and All Autodesk Tables	0	0 / Continuous	1
	autosp	TextBLStation	Text - B/L Station and Tics	0	0 / Continuous	2
	autosp	TextConstEle	Text - Construction Element	0	0 / Continuous	1
	autosp	TextCurveData	Text - Curve Data Note	0	0 / Continuous	2
	autosp	TextDetails	Text - Detail Notes	4	0 / Continuous	2
	autosp	TextDrainInvElev_ep	Text - Drainage Invert Elevation (Existing)	0	0 / Continuous	1
	autosp	TextDrainLabel_ep	Text - Drainage (Existing)	0	0 / Continuous	1
	autosp	TextElevLabel	Text - Elevation Labels	4	0 / Continuous	0
	autosp	TextLabel	Text - Label	0	0 / Continuous	2
	autosp	TextLandscape	Text - Landscape Labels	0	0 / Continuous	1
	autosp	TextMinor	Text - Minor	0	0 / Continuous	0
	autosp	TextMisc	Text - Miscellaneous	0	0 / Continuous	1
	autosp	TextNotes	Text - Notes	4	0 / Continuous	1
	autosp	TextProfLabel	Text - Profile, Horizontal and Vertical Axis Labels	0	0 / Continuous	2
	autosp	TextProjLabel	Text - Begin and End Project Label with Leader Lines	1	0 / Continuous	2
	autosp	TextPtLabel	Text - Point Labels	4	0 / Continuous	0
	autosp	TextShtNo	Text - Sheet Number	0	0 / Continuous	2
	autosp	TextSubUtilLabel_ep	Text - Subsurface Utilities (Existing)	0	0 / Continuous	1
	autosp	TextSurveyLabel	Text - Survey Labels	0	0 / Continuous	0
	autosp	TextTables	Text - Key Sheet Indexes and Table Data	4	0 / Continuous	2
	autosp	TextTitle	Text - Title	0	0 / Continuous	3
	autosp	TextTopoLabel_ep	Text - Topography (Existing)	0	0 / Continuous	1
	autosp	TextUtilLabel_ep	Text - Utilities (Existing)	0	0 / Continuous	1
	autosp	TextXSElev	Text - Cross Section Elevations	2	0 / Continuous	1
	autosp	TurningEle_dp	Turning Radius Elements (Miscellaneous)	4	0 / Continuous	1
	autosp	TurningRadius_dp	Turning Radius Line	3	3 / DGN3	1
	autosp	Vehicle	Vehicle for Calculating Turning Radius	7	0 / Continuous	2
	autosp	Viewport	Viewport (For AutoCAD Use)	3	0 / Continuous	0
	autosp	Xreference01_dp	Reference Files (For AutoCAD Use)	0	0 / Continuous	1
	autosp	Xreference02_dp	Reference Files (For AutoCAD Use)	0	0 / Continuous	1
	autosp	Xreference03_dp	Reference Files (For AutoCAD Use)	0	0 / Continuous	1
	autosp	Xreference04_dp	Reference Files (For AutoCAD Use)	0	0 / Continuous	1
	autosp	XSCell	GEOPAK Cross Section Cell/Block and Profile Cell/Block	8	0 / Continuous	1
	autosp	XSPt_ep	Cross Section Point, Station (Existing)	2	1 / DGN1	0

## CLIPRD - Clip Border

Critical	Rule	Level Name	Level Description	ByLevel Color	ByLevelStyle / Linetype	ByLevel Weight
	cliprd	ActivePointCell_dp	Active Point Cell	4	0 / Continuous	10
	cliprd	AdhocPoint_dp	Adhoc Points Placed by SheetInfo	0	4 / DGN4	0
	cliprd	ClipBorder_dp	CLIP Border and Civil 3D View Frame	3	0 / Continuous	0
	cliprd	ClipDrawingBound_dp	CLIP Drawing Boundary	3	3 / DGN3	0
	cliprd	Cloud_dp	Construction Cloud	7	0 / Continuous	2
	cliprd	COGO_dp	COGO Information	3	0 / Continuous	1
	cliprd	ConstArea_dp	Construction Area Crosshatch	0	0 / Continuous	1
	cliprd	ConstLimits	Construction Limits	3	RW-LimitsofConst	2
	cliprd	ConstLines	Construction Lines and References	1	0 / Continuous	0
	cliprd	ConstLines_pm	Construction Lines	4	0 / Continuous	0
	cliprd	DimLines_dp	Dimension Lines, Corresponding Terminators, Equation Lines	0	0 / Continuous	1
X	cliprd	EaseLicLine	Easement License Agreement Line	5	6 / DGN	0
	cliprd	GridMaj_dp	Grid Lines Major in Profile and Cross Section	3	0 / Continuous	1
	cliprd	GridMin_dp	Grid Lines Minor in Profile and Cross Section	0	0 / Continuous	0
	cliprd	GridMinSub_dp	Grid Lines Minor Sub on Cross Section Sheets	20	0 / Continuous	0
	cliprd	ImageAttachment_dp	Image Attachments	0	0 / Continuous	0
	cliprd	LeaderLine_dp	Leader Line and Terminator with Text	0	0 / Continuous	1
	cliprd	Logo_dp	Consultant Engineer of Record Logo	0	0 / Continuous	1
	cliprd	MatchLines_dp	Match Lines with Text, Arrows for Station Notations	1	0 / Continuous	2
	cliprd	Miscellaneous0	Undefined Proposed Item - Color Blue Weight 0	1	0 / Continuous	0
	cliprd	Miscellaneous1	Undefined Proposed Item - Color Blue Weight 1	1	0 / Continuous	1
	cliprd	Miscellaneous2	Undefined Proposed Item - Color Blue Weight 2	1	0 / Continuous	2
	cliprd	Miscellaneous3	Undefined Proposed Item - Color Green Weight 0	2	0 / Continuous	0
	cliprd	Miscellaneous4	Undefined Proposed Item - Color Green Weight 1	2	0 / Continuous	1
	cliprd	Miscellaneous5	Undefined Proposed Item - Color Green Weight 2	2	0 / Continuous	2
	cliprd	Miscellaneous6	Undefined Proposed Item - Color Red Weight 0	3	0 / Continuous	0
	cliprd	Miscellaneous7	Undefined Proposed Item - Color Red Weight 1	3	0 / Continuous	1
	cliprd	Miscellaneous8	Undefined Proposed Item - Color Red Weight 2	3	0 / Continuous	2
	cliprd	Miscellaneous9	Undefined Proposed Item - Color Red Weight 3	3	0 / Continuous	3
	cliprd	NonPlottingEle_dp	Non-Plotting Items - Construction Elements, Type 66 Elements, Etc.	4	0 / Continuous	0
	cliprd	NorthArw_dp	North Arrows	0	0 / Continuous	2
	cliprd	PayItem_dp	Pay Item Number Label Elements	4	0 / Continuous	2
X	cliprd	PlotBorder_dp	Plot Border	3	0 / Continuous	0
	cliprd	PointLocator_ep	Point Locator Symbol (Existing)	4	0 / Continuous	0
	cliprd	ReferencePt_dp	Survey and Construction Reference Point Details and Elements	4	0 / Continuous	2
	cliprd	RoadwayMisc	Roadway Items (Miscellaneous)	4	0 / Continuous	2
	cliprd	Scale_dp	Bar Scale, Scale Label Elements	0	0 / Continuous	2
	cliprd	Scratch1_dp	Scratch Level for Temporary or Informational Items	4	0 / Continuous	0
	cliprd	Scratch2_dp	Scratch Level for Temporary or Informational Items	5	0 / Continuous	0
	cliprd	ScratchEle_dp	Scratch Level for Draft Elements, Temporary Elements, Etc. (DO NOT PLOT)	3	0 / Continuous	0

Critical	Rule	Level Name	Level Description	ByLevel Color	ByLevelStyle / Linetype	ByLevel Weight
	cliprd	ScratchEle2_dp	Scratch Level for Draft Elements, Temporary Elements, Etc. (DO NOT PLOT)	4	0 / Continuous	0
	cliprd	SheetBorder_dp	Sheet Border	1	0 / Continuous	4
	cliprd	SheetLines_dp	Sheet Lines	1	0 / Continuous	2
	cliprd	SheetLinesMisc1_dp	Sheet Lines	1	0 / Continuous	0
	cliprd	SheetLinesMisc2_dp	Sheet Lines	2	0 / Continuous	2
	cliprd	SheetLinesMisc3_dp	Sheet Lines	3	0 / Continuous	2
	cliprd	SheetLinesMisc4_dp	Sheet Lines	4	0 / Continuous	2
	cliprd	SpecialDetails	Special Details	6	0 / Continuous	1
	cliprd	SumBoxBorder_dp	Summary Boxes Borders	4	0 / Continuous	3
	cliprd	SumBoxLines_dp	Summary Boxes Lines and Miscellaneous Items	4	0 / Continuous	1
	cliprd	SumBoxLinesMin_dp	Summary Boxes Lines Minor Line and Miscellaneous Items	4	0 / Continuous	0
	cliprd	Tables_dp	Data Tables and All Autodesk Tables	0	0 / Continuous	1
	cliprd	TextBLStation	Text - B/L Station and Tics	0	0 / Continuous	2
	cliprd	TextConstEle	Text - Construction Element	0	0 / Continuous	1
	cliprd	TextCurveData	Text - Curve Data Note	0	0 / Continuous	2
	cliprd	TextDetails	Text - Detail Notes	4	0 / Continuous	2
	cliprd	TextDrainInvElev_ep	Text - Drainage Invert Elevation (Existing)	0	0 / Continuous	1
	cliprd	TextDrainLabel_ep	Text - Drainage (Existing)	0	0 / Continuous	1
	cliprd	TextElevLabel	Text - Elevation Labels	4	0 / Continuous	0
	cliprd	TextLabel	Text - Label	0	0 / Continuous	2
	cliprd	TextLandscape	Text - Landscape Labels	0	0 / Continuous	1
	cliprd	TextMajor	Text - Major	0	0 / Continuous	5
	cliprd	TextMinor	Text - Minor	0	0 / Continuous	0
	cliprd	TextMisc	Text - Miscellaneous	0	0 / Continuous	1
	cliprd	TextNotes	Text - Notes	4	0 / Continuous	1
	cliprd	TextProfLabel	Text - Profile, Horizontal and Vertical Axis Labels	0	0 / Continuous	2
	cliprd	TextProjLabel	Text - Begin and End Project Label with Leader Lines	1	0 / Continuous	2
	cliprd	TextPtLabel	Text - Point Labels	4	0 / Continuous	0
	cliprd	TextShtNo	Text - Sheet Number	0	0 / Continuous	2
	cliprd	TextSubUtilLabel_ep	Text - Subsurface Utilities (Existing)	0	0 / Continuous	1
	cliprd	TextSurveyLabel	Text - Survey Labels	0	0 / Continuous	0
	cliprd	TextTables	Text - Key Sheet Indexes and Table Data	4	0 / Continuous	2
	cliprd	TextTitle	Text - Title	0	0 / Continuous	3
	cliprd	TextTopoLabel_ep	Text - Topography (Existing)	0	0 / Continuous	1
	cliprd	TextUtilLabel_ep	Text - Utilities (Existing)	0	0 / Continuous	1
	cliprd	TextXSElev	Text - Cross Section Elevations	2	0 / Continuous	1
	cliprd	Viewport	Viewport (For AutoCAD Use)	3	0 / Continuous	0
	cliprd	Xreference01_dp	Reference Files (For AutoCAD Use)	0	0 / Continuous	1
	cliprd	Xreference02_dp	Reference Files (For AutoCAD Use)	0	0 / Continuous	1
	cliprd	Xreference03_dp	Reference Files (For AutoCAD Use)	0	0 / Continuous	1
	cliprd	Xreference04_dp	Reference Files (For AutoCAD Use)	0	0 / Continuous	1
	cliprd	XSCell	GEOPAK Cross Section Cell/Block and Profile Cell/Block	8	0 / Continuous	1

## DRDTRD - Drainage Detail

Critical	Rule	Level Name	Level Description	ByLevel Color	ByLevelStyle / Linetype	ByLevel Weight
	drdtrd	ActivePointCell_dp	Active Point Cell	4	0 / Continuous	10
	drdtrd	AdhocPoint_dp	Adhoc Points Placed by SheetInfo	0	4 / DGN4	0
X	drdtrd	ArtificialCovering	Artificial Coverings	10	0 / Continuous	2
X	drdtrd	Berm	Berm (Top, Front, or Back)	10	0 / Continuous	2
X	drdtrd	BoxCulvert	Box Culvert	10	0 / Continuous	2
X	drdtrd	Canal	Canal	7	0 / Continuous	1
X	drdtrd	CatchBasin	Catch Basin	10	0 / Continuous	2
	drdtrd	Cloud_dp	Construction Cloud	7	0 / Continuous	2
	drdtrd	COGO_dp	COGO Information	3	0 / Continuous	1
	drdtrd	ConstArea_dp	Construction Area Crosshatch	0	0 / Continuous	1
	drdtrd	ConstLimits	Construction Limits	3	RW-LimitsofConst	2
	drdtrd	ConstLines	Construction Lines and References	1	0 / Continuous	0
	drdtrd	ConstLines_pm	Construction Lines	4	0 / Continuous	0
	drdtrd	ContoursMinor	Contour Lines Minor	4	0 / Continuous	2
X	drdtrd	DesiltingPipes	De-silting Pipes	10	0 / Continuous	2
	drdtrd	DimLines_dp	Dimension Lines, Corresponding Terminators, Equation Lines	0	0 / Continuous	1
X	drdtrd	Ditch	Ditch Top	7	6 / DGN6	1
X	drdtrd	DitchBot	Ditch Bottom	10	0 / Continuous	2
	drdtrd	DitchProfLt_er	Ditch Profile Left (Existing)	8	3 / DGN3	1
	drdtrd	DitchProfLt_pr	Ditch Profile Left	8	0 / Continuous	1
	drdtrd	DitchProfMdn_er	Ditch Profile Median (Existing)	10	3 / DGN3	1
	drdtrd	DitchProfMdn_pr	Ditch Profile Median	10	0 / Continuous	1
	drdtrd	DitchProfRt_er	Ditch Profile Right (Existing)	9	3 / DGN3	1
	drdtrd	DitchProfRt_pr	Ditch Profile Right	9	0 / Continuous	1
	drdtrd	DrainDivideArw	Drainage Divide Arrow	0	0 / Continuous	1
	drdtrd	DrainDivides00	Drainage Divides	10	2 / DGN2	4
	drdtrd	DrainDivides00_ep	Drainage Divides (Existing)	9	2 / DGN2	4
	drdtrd	DrainDivides01	Drainage Divides	10	2 / DGN2	4
	drdtrd	DrainDivides01_ep	Drainage Divides (Existing)	9	2 / DGN2	4
	drdtrd	DrainDivides02	Drainage Divides	10	2 / DGN2	4
	drdtrd	DrainDivides02_ep	Drainage Divides (Existing)	9	2 / DGN2	4
	drdtrd	DrainDivides03	Drainage Divides	10	2 / DGN2	4
	drdtrd	DrainDivides03_ep	Drainage Divides (Existing)	9	2 / DGN2	4
	drdtrd	DrainDivides04	Drainage Divides	10	2 / DGN2	4
	drdtrd	DrainDivides04_ep	Drainage Divides (Existing)	9	2 / DGN2	4
	drdtrd	DrainDivides05	Drainage Divides	10	2 / DGN2	4
	drdtrd	DrainDivides05_ep	Drainage Divides (Existing)	9	2 / DGN2	4
	drdtrd	DrainDivides06	Drainage Divides	10	2 / DGN2	4
	drdtrd	DrainDivides06_ep	Drainage Divides (Existing)	9	2 / DGN2	4
	drdtrd	DrainDivides07	Drainage Divides	10	2 / DGN2	4
	drdtrd	DrainDivides07_ep	Drainage Divides (Existing)	9	2 / DGN2	4
	drdtrd	DrainDivides08	Drainage Divides	10	2 / DGN2	4
	drdtrd	DrainDivides08_ep	Drainage Divides (Existing)	9	2 / DGN2	4
	drdtrd	DrainDivides09	Drainage Divides	10	2 / DGN2	4



Critical	Rule	Level Name	Level Description	ByLevel Color	ByLevelStyle / Linetype	ByLevel Weight
	drdtrd	DrainDivides09_ep	Drainage Divides (Existing)	9	2 / DGN2	4
	drdtrd	DrainMisc	Drainage Items (Miscellaneous)	10	0 / Continuous	1
	drdtrd	DrainMisc_pm	Drainage Items (Proposed Model) (Miscellaneous)	10	0 / Continuous	2
X	drdtrd	DrainStruct	Drainage Structure in Plan	10	2 / DGN2	2
X	drdtrd	DrainStruct_pr	Drainage Structures (All Types)	10	0 / Continuous	2
X	drdtrd	EaseLicLine	Easement License Agreement Line	5	6 / DGN6	0
X	drdtrd	EasePerpLine	Easement Lines Perpetual	4	RW-PerpetualEasement	1
X	drdtrd	EaseTempLine	Easement Lines Temporary	6	RW-TemporaryEasement	0
X	drdtrd	EdgeDrain	Edge Drain, Material and Outlet Pipe	10	0 / Continuous	2
X	drdtrd	Endwall	Endwall (All Types)	10	0 / Continuous	2
	drdtrd	Fence_ex	Fence Lines on Cross Sections (Existing)	6	3 / DGN3	1
X	drdtrd	FES	Flared End Sections	10	0 / Continuous	2
X	drdtrd	FlapGate	Flap Gates	10	0 / Continuous	2
X	drdtrd	FlowLine	Flow Line	10	0 / Continuous	2
	drdtrd	FlowLine_pr	Flow Line (Roadway Profile View)	0	0 / Continuous	2
X	drdtrd	FrenchDrain	French Drain	10	0 / Continuous	2
X	drdtrd	GovSectionLine_ep	Section Lines (Existing)	10	RW-SectionLine	2
X	drdtrd	GovTwpRgeLine_ep	Township / Range Lines (Existing)	10	RW-TownshipRange	2
	drdtrd	GPKDrBack_dp	Back Point on Drainage Cells	2	2 / DGN2	2
	drdtrd	GPKDrBottom_dp	Bottom Point on Drainage Cells	3	3 / DGN3	2
	drdtrd	GPKDrCellIns_dp	Cell Insertion Point on Drainage Cells	4	4 / DGN4	2
	drdtrd	GPKDrCentroid_dp	Point on Centroid for Drainage	7	7 / DGN7	2
	drdtrd	GPKDrElv	Location Point for Drainage Cells	5	5 / DGN5	2
	drdtrd	GPKDrFront_dp	Front Point on Drainage Cells	1	1 / DGN1	2
	drdtrd	GPKDrPipe_dp	Point on Drainage Pipe	6	6 / DGN6	2
	drdtrd	GPKDrPipeCir_dp	Point on Pipe Circular	6	6 / DGN6	0
	drdtrd	GradeLine_er	Grade Line Profile (Existing)	2	2 / DGN2	1
	drdtrd	GradeLine_pr	Grade Line Profile	5	0 / Continuous	2
	drdtrd	GradeLineCtr_dp	Grade Line Profile Center (Shown in Plan View)	5	0 / Continuous	0
	drdtrd	GradeLineCtr_pr	Grade Line Profile Center	5	0 / Continuous	2
	drdtrd	GradeLineLt_dp	Grade Line Profile Left (Shown in Plan View)	1	0 / Continuous	0
	drdtrd	GradeLineLt_er	Grade Line Profile Left (Existing)	1	2 / DGN2	1
	drdtrd	GradeLineLt_pr	Grade Line Profile Left	1	0 / Continuous	2
	drdtrd	GradeLineRt_dp	Grade Line Profile Right (Shown in Plan View)	4	0 / Continuous	0
	drdtrd	GradeLineRt_er	Grade Line Profile Right (Existing)	4	2 / DGN2	1
	drdtrd	GradeLineRt_pr	Grade Line Profile Right	4	0 / Continuous	2
	drdtrd	GradeSecPat	Grade Section Patterns	0	0 / Continuous	0
	drdtrd	GridMaj_dp	Grid Lines Major in Profile and Cross Section	3	0 / Continuous	1
	drdtrd	GridMin_dp	Grid Lines Minor in Profile and Cross Section	0	0 / Continuous	0
	drdtrd	GridMinSub_dp	Grid Lines Minor Sub on Cross Section Sheets	20	0 / Continuous	0
	drdtrd	ImageAttachment_dp	Image Attachments	0	0 / Continuous	0
X	drdtrd	InletBottomJ	Inlet Bottom Type J	10	0 / Continuous	1
X	drdtrd	InletBottomP	Inlet Bottom Type P	10	0 / Continuous	1
X	drdtrd	InletClosedFlume	Closed Flume Inlet	10	0 / Continuous	2
X	drdtrd	InletCurb	Curb Inlet (All Types)	10	0 / Continuous	2
X	drdtrd	InletDBI	Ditch Bottom Inlet (All Types)	10	0 / Continuous	2

Critical	Rule	Level Name	Level Description	ByLevel Color	ByLevelStyle / Linetype	Bylevel Weight
X	drdtrd	InletGutter	Gutter Inlet (All Types)	10	0 / Continuous	2
X	drdtrd	InletMedian	Median Barrier Inlet	10	0 / Continuous	2
X	drdtrd	InletProt	Rock Bags and Sand Bagging	10	SWP-RockBags	2
X	drdtrd	LARWLine	Limited Access Right of Way Lines	4	RW-LimitedAccess-Proposed	2
X	drdtrd	LARWLine_ep	Limited Access Right of Way Lines (Existing)	4	RW-LimitedAccess-Existing	1
	drdtrd	LeaderLine_dp	Leader Line and Terminator with Text	0	0 / Continuous	1
	drdtrd	Logo_dp	Consultant Engineer of Record Logo	0	0 / Continuous	1
X	drdtrd	Manhole	Manhole (Drainage and Unknown)	10	0 / Continuous	2
X	drdtrd	MES	Mitered End Section	10	0 / Continuous	2
	drdtrd	Miscellaneous0	Undefined Proposed Item - Color Blue Weight 0	1	0 / Continuous	0
	drdtrd	Miscellaneous1	Undefined Proposed Item - Color Blue Weight 1	1	0 / Continuous	1
	drdtrd	Miscellaneous2	Undefined Proposed Item - Color Blue Weight 2	1	0 / Continuous	2
	drdtrd	Miscellaneous3	Undefined Proposed Item - Color Green Weight 0	2	0 / Continuous	0
	drdtrd	Miscellaneous4	Undefined Proposed Item - Color Green Weight 1	2	0 / Continuous	1
	drdtrd	Miscellaneous5	Undefined Proposed Item - Color Green Weight 2	2	0 / Continuous	2
	drdtrd	Miscellaneous6	Undefined Proposed Item - Color Red Weight 0	3	0 / Continuous	0
	drdtrd	Miscellaneous7	Undefined Proposed Item - Color Red Weight 1	3	0 / Continuous	1
	drdtrd	Miscellaneous8	Undefined Proposed Item - Color Red Weight 2	3	0 / Continuous	2
	drdtrd	Miscellaneous9	Undefined Proposed Item - Color Red Weight 3	3	0 / Continuous	3
	drdtrd	NonPlottingEle_dp	Non-Plotting Items - Construction Elements, Type 66 Elements, Etc.	4	0 / Continuous	0
	drdtrd	Patternlines_ep	Cross Section Chain (Existing)	2	1 / DGN1	0
	drdtrd	PatternLines1_dp	Pattern Lines on Cross Sections and All Autodesk (Civil 3D) Tables	3	0 / Continuous	2
	drdtrd	PatternLines2_dp	Pattern Lines on Cross Sections Alternate for Side Streets, CriticalCross Sections or Drainage Structures	4	0 / Continuous	2
	drdtrd	PatternLines3_dp	Pattern Lines on Cross Sections Alternate for Side Streets, CriticalCross Sections or Drainage Structures	5	0 / Continuous	2
	drdtrd	PayItem_dp	Pay Item Number Label Elements	4	0 / Continuous	2
	drdtrd	Permit1	Permit 1 Wetlands, Mitigation Sites, Planting Areas	1	0 / Continuous	1
	drdtrd	Permit2	Permit 2 Wetlands, Mitigation Sites, Planting Areas	2	0 / Continuous	1
	drdtrd	Permit3	Permit 3 Wetlands, Mitigation Sites, Planting Areas	4	0 / Continuous	1
X	drdtrd	PipeCulvert	Pipe Culvert in Plan	10	2 / DGN2	2
	drdtrd	PipeCulvert_ep	Pipe Culvert (Existing)	10	3 / DGN3	1
X	drdtrd	PipeCulvert_pr	Pipe Culvert in Profile	10	0 / Continuous	2
X	drdtrd	PipeCulvert_px	Pipe Culvert on Cross Section View	10	0 / Continuous	2
X	drdtrd	PipeCulvertCD	Pipe Culvert Cross Drain	10	0 / Continuous	2
X	drdtrd	PipeCulvertGD	Pipe Culvert Gutter Drain	10	0 / Continuous	2
X	drdtrd	PipeCulvertSD	Pipe Culvert Side Drain	10	0 / Continuous	2
X	drdtrd	PipeCulvertSS	Pipe Culvert Storm Sewer	10	0 / Continuous	2
X	drdtrd	PlotBorder_dp	Plot Border	3	0 / Continuous	0
	drdtrd	PointLocator_ep	Point Locator Symbol (Existing)	4	0 / Continuous	0
X	drdtrd	Pond_px	Pond Lines on Cross Sections	2	0 / Continuous	2
X	drdtrd	PondSideSlope	Pond Side Slope	0	0 / Continuous	2
X	drdtrd	PropertyLine_ep	Property Lines (Existing)	3	0 / Continuous	0
	drdtrd	ReferencePt_dp	Survey and Construction Reference Point Details and Elements	4	0 / Continuous	2
X	drdtrd	RetentionArea	Retention Area	2	0 / Continuous	2
X	drdtrd	RipRap	Rip Rap, Rubble	4	0 / Continuous	2
X	drdtrd	RockGravelStone	Rock, Gravel, Stone, Boulders, Etc.	1	0 / Continuous	2

Critical	Rule	Level Name	Level Description	ByLevel Color	ByLevelStyle / Linetype	ByLevel Weight
X	drdtrd	RWLine	Right of Way Lines	4	RW-Proposed	2
X	drdtrd	RWLine_ep	Right of Way Lines (Existing)	3	RW-Existing	1
	drdtrd	Scratch1_dp	Scratch Level for Temporary or Informational Items	4	0 / Continuous	0
	drdtrd	Scratch2_dp	Scratch Level for Temporary or Informational Items	5	0 / Continuous	0
	drdtrd	ScratchEle_dp	Scratch Level for Draft Elements, Temporary Elements, Etc. (DO NOT PLOT)	3	0 / Continuous	0
	drdtrd	ScratchEle2_dp	Scratch Level for Draft Elements, Temporary Elements, Etc. (DO NOT PLOT)	4	0 / Continuous	0
101	drdtrd	SedimentBarrier	Synthetic Bales and Staked Silt Fences	10	SWP-HayBales	2
101	drdtrd	SedimentBarrier	Synthetic Bales and Staked Silt Fences	10	SWP-SiltFence	2
X	drdtrd	SedimentBasin	Sediment Basin Index 101	10	0 / Continuous	2
X	drdtrd	SedimentBasin_ep	Sediment Basin Index 101 (Existing)	10	3 / DGN3	1
	drdtrd	SheetBorder_dp	Sheet Border	1	0 / Continuous	4
	drdtrd	SheetLines_dp	Sheet Lines	1	0 / Continuous	2
	drdtrd	SheetLinesMisc1_dp	Sheet Lines	1	0 / Continuous	0
	drdtrd	SheetLinesMisc2_dp	Sheet Lines	2	0 / Continuous	2
	drdtrd	SheetLinesMisc3_dp	Sheet Lines	3	0 / Continuous	2
	drdtrd	SheetLinesMisc4_dp	Sheet Lines	4	0 / Continuous	2
X	drdtrd	SlideGate	Slide Gate	10	0 / Continuous	2
X	drdtrd	Slopes	Slopes (Top, Bottom)	9	3 / DGN3	0
X	drdtrd	SlopeStakes1	Slope Stakes 1	4	1 / DGN1	3
X	drdtrd	SlopeStakes2	Slope Stakes 2	1	1 / DGN1	3
X	drdtrd	SlottedDrainPipe	Slotted Drain Pipe	10	0 / Continuous	1
X	drdtrd	SlottedStormSewer	Storm Sewer (Slotted or Perforated)	10	0 / Continuous	2
	drdtrd	SpecialDetails	Special Details	6	0 / Continuous	1
	drdtrd	SpecialDetails_px	Special Details on Cross Sections	6	0 / Continuous	1
X	drdtrd	Spillway	Spillway/ Flume/ Slope Drain	10	0 / Continuous	2
X	drdtrd	StormSewer	Storm Sewer (All Types), Drain Pipes and Spouts	10	0 / Continuous	2
	drdtrd	SumBoxBorder_dp	Summary Boxes Borders	4	0 / Continuous	3
	drdtrd	SumBoxLines_dp	Summary Boxes Lines and Miscellaneous Items	4	0 / Continuous	1
	drdtrd	SumBoxLinesMin_dp	Summary Boxes Lines Minor Line and Miscellaneous Items	4	0 / Continuous	0
	drdtrd	Tables_dp	Data Tables and All Autodesk Tables	0	0 / Continuous	1
X	drdtrd	TerrainLine_ex	Ground Line for Multiline on Cross Sections (Existing)	5	0 / Continuous	1
	drdtrd	TextAlert	Text - Alert Label to Highlight a Problem	3	0 / Continuous	2
	drdtrd	TextBLStation	Text - B/L Station and Tics	0	0 / Continuous	2
	drdtrd	TextConstEle	Text - Construction Element	0	0 / Continuous	1
	drdtrd	TextCurveData	Text - Curve Data Note	0	0 / Continuous	2
	drdtrd	TextDetails	Text - Detail Notes	4	0 / Continuous	2
	drdtrd	TextDrainInvElev_ep	Text - Drainage Invert Elevation (Existing)	0	0 / Continuous	1
	drdtrd	TextDrainLabel_ep	Text - Drainage (Existing)	0	0 / Continuous	1
	drdtrd	TextElevLabel	Text - Elevation Labels	4	0 / Continuous	0
	drdtrd	TextLabel	Text - Label	0	0 / Continuous	2
	drdtrd	TextLandscape	Text - Landscape Labels	0	0 / Continuous	1
	drdtrd	TextMajor	Text - Major	0	0 / Continuous	5
	drdtrd	TextMinor	Text - Minor	0	0 / Continuous	0
	drdtrd	TextMisc	Text - Miscellaneous	0	0 / Continuous	1
	drdtrd	TextNotes	Text - Notes	4	0 / Continuous	1

Critical	Rule	Level Name	Level Description	ByLevel Color	ByLevelStyle / Linetype	Bylevel Weight
	drdtrd	TextProfLabel	Text - Profile, Horizontal and Vertical Axis Labels	0	0 / Continuous	2
	drdtrd	TextProjLabel	Text - Begin and End Project Label with Leader Lines	1	0 / Continuous	2
	drdtrd	TextPtLabel	Text - Point Labels	4	0 / Continuous	0
	drdtrd	TextShtNo	Text - Sheet Number	0	0 / Continuous	2
	drdtrd	TextSubUtilLabel_ep	Text - Subsurface Utilities (Existing)	0	0 / Continuous	1
	drdtrd	TextSurveyLabel	Text - Survey Labels	0	0 / Continuous	0
	drdtrd	TextTables	Text - Key Sheet Indexes and Table Data	4	0 / Continuous	2
	drdtrd	TextTitle	Text - Title	0	0 / Continuous	3
	drdtrd	TextTopoLabel_ep	Text - Topography (Existing)	0	0 / Continuous	1
	drdtrd	TextUtilLabel_ep	Text - Utilities (Existing)	0	0 / Continuous	1
	drdtrd	TextXSElev	Text - Cross Section Elevations	2	0 / Continuous	1
X	drdtrd	Trench	Storm Sewer Trench	10	0 / Continuous	2
X	drdtrd	TurbidityBarrier1	Turbidity Barrier 1 (Floating)	10	SWP-TurbidityBarrier-Type1	2
	drdtrd	TurbidityBarrier1_ep	Turbidity Barrier (Floating) (Existing)	10	1 / DGN1	2
X	drdtrd	TurbidityBarrier2	Turbidity Barrier 2 (Staked)	10	SWP-TurbidityBarrier-Type2	2
	drdtrd	TurbidityBarrier2_ep	Turbidity Barrier 2 (Staked) (Existing)	10	1 / DGN1	2
X	drdtrd	UnderDrain	Underdrains (All Types)	10	0 / Continuous	2
X	drdtrd	UnderDrainOP	Underdrains Outlet Pipes	10	0 / Continuous	2
	drdtrd	Viewport	Viewport (For AutoCAD Use)	3	0 / Continuous	0
	drdtrd	Wetland	Wetland Boundary	2	RD-Wetland-Proposed	1
	drdtrd	Xreference01_dp	Reference Files (For AutoCAD Use)	0	0 / Continuous	1
	drdtrd	Xreference02_dp	Reference Files (For AutoCAD Use)	0	0 / Continuous	1
	drdtrd	Xreference03_dp	Reference Files (For AutoCAD Use)	0	0 / Continuous	1
	drdtrd	Xreference04_dp	Reference Files (For AutoCAD Use)	0	0 / Continuous	1
	drdtrd	XSCell	GEOPAK Cross Section Cell/Block and Profile Cell/Block	8	0 / Continuous	1
X	drdtrd	XSExtendGrdLine_ex	Cross Section Extend Ground Lines (Existing)	21	2 / DGN2	1
X	drdtrd	XSGrdLine_ex	Cross Section Ground Lines (Existing)	2	2 / DGN2	1
X	drdtrd	XSGrdLine_px	Cross Section Roadway Ground Lines	1	0 / Continuous	2
	drdtrd	XSPt_ep	Cross Section Point, Station (Existing)	2	1 / DGN1	0
X	drdtrd	YardDrain	Yard Drain	10	3 / DGN3	1

## DREXRD - Existing Drainage

Critical	Rule	Level Name	Level Description	ByLevel Color	ByLevelStyle / Linetype	Bylevel Weight	Point / Line	Feature Code
	drexrd	Basins_ep	Sediment Basins, Retention Ponds (Existing)	10	3 / DGN3	1	L	BAS
	drexrd	BoxCulvert_ep	Box Culvert (Existing)	10	3 / DGN3	1	L	BXC
	drexrd	ConstLines	Construction Lines and References	1	0 / Continuous	0		
	drexrd	ConstLines_pm	Construction Lines	4	0 / Continuous	0		
	drexrd	CrossDrain_ep	Underdrains and Cross drains (Existing)	10	3 / DGN3	1	L	UD
	drexrd	Ditch_ep	Ditch (Top, Bottom and Flow Lines) (Existing)	7	6 / DGN6	0	L	DTCH
	drexrd	DitchPavt_ep	Ditch Pavement (Existing)	0	1 / DGN1	0	L	DTCHP
	drexrd	DrainMisc_ep	Catch Basins (Existing)	10	3 / DGN3	1	L	CB
	drexrd	DrainMisc_ep	Drainage Pipes and Spouts (Existing)	10	3 / DGN3	1	L	DRNP
	drexrd	DrainMisc_ep	Drainage Junction Box (Existing)	10	3 / DGN3	1	L	JB
	drexrd	DrainMisc_ep	Special Drainage Feature (Describe) (Existing)	10	3 / DGN3	1	L	SPD
	drexrd	DrainMisc_ep	Spillways, Flumes or Scuppers (Existing)	10	3 / DGN3	1	L	SPL
	drexrd	DrainMisc_ep	Yard Drain (Existing)	10	3 / DGN3	1	L	YD
	drexrd	EndTreat_ep	Flared End Section (Existing)	10	3 / DGN3	1	L	FES
	drexrd	EndTreat_ep	Mitered End Section (Existing)	10	3 / DGN3	1	L	MES
	drexrd	EndTreat_ep	Straight Endwall (Existing)	10	3 / DGN3	1	L	SEW
	drexrd	EndTreat_ep	Special Endwall (Existing)	10	3 / DGN3	1	L	SPEW
	drexrd	EndTreat_ep	U-Type Endwall (Existing)	10	3 / DGN3	1	L	UEW
	drexrd	EndTreat_ep	Winged End wall (Existing)	10	3 / DGN3	1	L	WEW
	drexrd	ImageAttachment_dp	Image Attachments	0	0 / Continuous	0		
	drexrd	InletBottom_ep	Drainage Structure Bottoms (Existing)	10	3 / DGN3	1	L	DRNB
	drexrd	InletCurb_ep	Curb Inlets (Existing)	10	3 / DGN3	1	L	CINL
	drexrd	InletCurb_ep	Median Inlets (Existing)	10	3 / DGN3	1	L	MEDI
	drexrd	InletDBI_ep	Ditch Bottom Inlet (Existing)	10	3 / DGN3	1	L	DTCHI
	drexrd	InletGutter_ep	Gutter Inlets (All Types) (Existing)	10	3 / DGN3	1	L	GI
	drexrd	LeaderLine_dp	Leader Line and Terminator with Text	0	0 / Continuous	1		
	drexrd	ManholeSW_ep	Manhole (Storm Water) (Existing)	10	1 / DGN1	0	P	MHD
	drexrd	ManholeUnknown_ep	Manhole (Unknown) (Existing)	0	1 / DGN1	1	P	MH
	drexrd	PipeCulvert_ep	Pipe Culvert (Existing)	10	3 / DGN3	1	L	PCULV
	drexrd	StormSewer_ep	Storm Sewer (All Sizes), Drain Pipes and Spouts (Existing)	10	3 / DGN3	1	L	STS
	drexrd	Tables_dp	Data Tables and All Autodesk Tables (Existing)	0	0 / Continuous	1		
	drexrd	TextDrainInvElev_ep	Text - Drainage Invert Elevation (Existing)	0	0 / Continuous	1		
	drexrd	TextDrainLabel_ep	Text - Drainage (Existing)	0	0 / Continuous	1		
	drexrd	TextMisc	Text - Miscellaneous	0	0 / Continuous	1		
	drexrd	TextNotes	Text - Notes	4	0 / Continuous	1		
	drexrd	UnderDrain_ep	Under Drain Box (Existing)	10	3 / DGN3	0	P	UDBX
	drexrd	Viewport	Viewport (For AutoCAD Use)	3	0 / Continuous	0		
	drexrd	Xreference01_dp	Reference Files (For AutoCAD Use)	0	0 / Continuous	1		
	drexrd	Xreference02_dp	Reference Files (For AutoCAD Use)	0	0 / Continuous	1		
	drexrd	Xreference03_dp	Reference Files (For AutoCAD Use)	0	0 / Continuous	1		
	drexrd	Xreference04_dp	Reference Files (For AutoCAD Use)	0	0 / Continuous	1		

## DRMPRD - Drainage Map

Critical	Rule	Level Name	Level Description	ByLevel Color	ByLevelStyle / Linetype	ByLevel Weight
	drmprd	ActivePointCell_dp	Active Point Cell	4	0 / Continuous	10
	drmprd	AdhocPoint_dp	Adhoc Points Placed by SheetInfo	0	4 / DGN4	0
X	drmprd	ArtificialCovering	Artificial Coverings	10	0 / Continuous	2
	drmprd	Assembly_dp	Civil 3D Assemblies and Subassemblies	4	0 / Continuous	2
	drmprd	BaselineSurvey	Baseline Survey	0	0 / Continuous	2
X	drmprd	Berm	Berm (Top, Front, or Back)	10	0 / Continuous	2
X	drmprd	BoxCulvert	Box Culvert	10	0 / Continuous	2
X	drmprd	Canal	Canal	7	0 / Continuous	1
X	drmprd	CatchBasin	Catch Basin	10	0 / Continuous	2
	drmprd	CLConst_dp	Center Line of Construction	0	0 / Continuous	2
	drmprd	Cloud_dp	Construction Cloud	7	0 / Continuous	2
	drmprd	COGO_dp	COGO Information	3	0 / Continuous	1
	drmprd	ConstArea_dp	Construction Area Crosshatch	0	0 / Continuous	1
	drmprd	ConstLimits	Construction Limits	3	RW-LimitsofConst	2
	drmprd	ConstLines	Construction Lines and References	1	0 / Continuous	0
	drmprd	ConstLines_pm	Construction Lines	4	0 / Continuous	0
	drmprd	Corridors_dp	Civil 3D Corridors	0	0 / Continuous	2
	drmprd	CurveData_dp	Curve and Coordinate Data Elements Incl. PC, PT, PI Symbols	4	0 / Continuous	2
	drmprd	CurveDataLabel_dp	Curve Data Labels PC,PI, PT	0	0 / Continuous	2
X	drmprd	DesiltingPipes	DesiltingDe-silting Pipes	10	0 / Continuous	2
	drmprd	DimLines_dp	Dimension Lines, Corresponding Terminators, Equation Lines	0	0 / Continuous	1
X	drmprd	Ditch	Ditch Top	7	6 / DGN6	1
X	drmprd	DitchBot	Ditch Bottom	10	0 / Continuous	2
	drmprd	DitchProfLt_er	Ditch Profile Left (Existing)	8	3 / DGN3	1
	drmprd	DitchProfLt_pr	Ditch Profile Left	8	0 / Continuous	1
	drmprd	DitchProfMdn_er	Ditch Profile Median (Existing)	10	3 / DGN3	1
	drmprd	DitchProfMdn_pr	Ditch Profile Median	10	0 / Continuous	1
	drmprd	DitchProfRt_er	Ditch Profile Right (Existing)	9	3 / DGN3	1
	drmprd	DitchProfRt_pr	Ditch Profile Right	9	0 / Continuous	1
	drmprd	DrainAlert_px	Alert Symbology for Structural Elements on Cross Sections	3	0 / Continuous	2
	drmprd	DrainDivideArw	Drainage Divide Arrow	0	0 / Continuous	1
	drmprd	DrainDivides00	Drainage Divides	10	2 / DGN2	4
	drmprd	DrainDivides00_ep	Drainage Divides (Existing)	9	2 / DGN2	4
	drmprd	DrainDivides01	Drainage Divides	10	2 / DGN2	4
	drmprd	DrainDivides01_ep	Drainage Divides (Existing)	9	2 / DGN2	4
	drmprd	DrainDivides02	Drainage Divides	10	2 / DGN2	4
	drmprd	DrainDivides02_ep	Drainage Divides (Existing)	9	2 / DGN2	4
	drmprd	DrainDivides03	Drainage Divides	10	2 / DGN2	4
	drmprd	DrainDivides03_ep	Drainage Divides (Existing)	9	2 / DGN2	4
	drmprd	DrainDivides04	Drainage Divides	10	2 / DGN2	4
	drmprd	DrainDivides04_ep	Drainage Divides (Existing)	9	2 / DGN2	4
	drmprd	DrainDivides05	Drainage Divides	10	2 / DGN2	4
	drmprd	DrainDivides05_ep	Drainage Divides (Existing)	9	2 / DGN2	4
	drmprd	DrainDivides06	Drainage Divides	10	2 / DGN2	4

Critical	Rule	Level Name	Level Description	ByLevel Color	ByLevelStyle / Linetype	ByLevel Weight
	drmprd	DrainDivides06_ep	Drainage Divides (Existing)	9	2 / DGN2	4
	drmprd	DrainDivides07	Drainage Divides	10	2 / DGN2	4
	drmprd	DrainDivides07_ep	Drainage Divides (Existing)	9	2 / DGN2	4
	drmprd	DrainDivides08	Drainage Divides	10	2 / DGN2	4
	drmprd	DrainDivides08_ep	Drainage Divides (Existing)	9	2 / DGN2	4
	drmprd	DrainDivides09	Drainage Divides	10	2 / DGN2	4
	drmprd	DrainDivides09_ep	Drainage Divides (Existing)	9	2 / DGN2	4
	drmprd	DrainMisc	Drainage Items (Miscellaneous)	3	0 / Continuous	1
	drmprd	DrainMisc_pm	Drainage Items (Proposed Model) (Miscellaneous)	10	0 / Continuous	1
	drmprd	DrainStruct	Drainage Structure in Plan	10	2 / DGN2	2
X	drmprd	DrainStruct_pr	Drainage Structures (All Types)	10	0 / Continuous	2
X	drmprd	EaseLicLine	Easement License Agreement Line	5	6 / DGN6	0
X	drmprd	EasePerpLine	Easement Lines Perpetual	4	RW-PerpetualEasement	1
X	drmprd	EaseTempLine	Easement Lines Temporary	6	RW-TemporaryEasement	0
X	drmprd	EdgeDrain	Edge Drain, Material and Outlet Pipe	10	0 / Continuous	2
X	drmprd	Endwall	Endwall (All Types)	10	0 / Continuous	2
	drmprd	Fence_ex	Fence Lines on Cross Sections (Existing)	6	3 / DGN3	1
X	drmprd	FES	Flared End Sections	10	0 / Continuous	2
X	drmprd	FlapGate	Flap Gates	10	0 / Continuous	2
X	drmprd	FlowLine	Flow Line	10	0 / Continuous	2
	drmprd	FlowLine_pr	Flow Line (Roadway Profile View)	0	0 / Continuous	2
X	drmprd	FlowPaths	Time of Concentration Flow Paths	10	1 / DGN1	1
X	drmprd	FrenchDrain	French Drain	10	0 / Continuous	2
X	drmprd	Gabions	Gabion Baskets or Mats	10	0 / Continuous	2
X	drmprd	Gabions_ep	Gabion Baskets or Mats (Existing)	10	1 / DGN1	2
X	drmprd	GovTwpRgeLine_ep	Township / Range Lines (Existing)	10	RW-TownshipRange	2
	drmprd	GPKDrBack_dp	Back Point on Drainage Cells	2	2 / DGN2	2
	drmprd	GPKDrBottom_dp	Bottom Point on Drainage Cells	3	3 / DGN3	2
	drmprd	GPKDrCellIns_dp	Cell Insertion Point on Drainage Cells	4	4 / DGN4	2
	drmprd	GPKDrCentroid_dp	Point on Centroid for Drainage	7	7 / DGN7	2
	drmprd	GPKDrElv	Location Point for Drainage Cells	5	5 / DGN5	2
	drmprd	GPKDrFront_dp	Front Point on Drainage Cells	1	1 / DGN1	2
	drmprd	GPKDrPipe_dp	Point on Drainage Pipe	6	6 / DGN6	2
	drmprd	GPKDrPipeCir_dp	Point on Pipe Circular	6	6 / DGN6	0
	drmprd	GradeLine_er	Grade Line Profile (Existing)	2	2 / DGN2	1
	drmprd	GradeLine_pr	Grade Line Profile	5	0 / Continuous	2
	drmprd	GradeLineCtr_dp	Grade Line Profile Center (Shown in Plan View)	5	0 / Continuous	0
	drmprd	GradeLineCtr_pr	Grade Line Profile Center	5	0 / Continuous	2
	drmprd	GradeLineLt_dp	Grade Line Profile Left (Shown in Plan View)	1	0 / Continuous	0
	drmprd	GradeLineLt_er	Grade Line Profile Left (Existing)	1	2 / DGN2	1
	drmprd	GradeLineLt_pr	Grade Line Profile Left	1	0 / Continuous	2
	drmprd	GradeLineRt_dp	Grade Line Profile Right (Shown in Plan View)	4	0 / Continuous	0
	drmprd	GradeLineRt_er	Grade Line Profile Right (Existing)	4	2 / DGN2	1
	drmprd	GradeLineRt_pr	Grade Line Profile Right	4	0 / Continuous	2
	drmprd	GradeSecPat	Grade Section Patterns	0	0 / Continuous	0
	drmprd	GridMaj_dp	Grid Lines Major in Profile and Cross Section	3	0 / Continuous	1



Critical	Rule	Level Name	Level Description	ByLevel Color	ByLevelStyle / Linetype	ByLevel Weight
	drmprd	GridMin_dp	Grid Lines Minor in Profile and Cross Section	0	0 / Continuous	0
	drmprd	GridMinSub_dp	Grid Lines Minor Sub on Cross Section Sheets	20	0 / Continuous	0
	drmprd	ImageAttachment_dp	Image Attachments	0	0 / Continuous	0
X	drmprd	InletClosedFlume	Closed Flume Inlet	10	0 / Continuous	2
X	drmprd	InletCurb	Curb Inlet (All Types)	10	0 / Continuous	2
X	drmprd	InletDBI	Ditch Bottom Inlet (All Types)	10	0 / Continuous	2
X	drmprd	InletGutter	Gutter Inlet (All Types)	10	0 / Continuous	2
X	drmprd	InletMedian	Median Barrier Inlet	10	0 / Continuous	2
X	drmprd	InletProt	Rock Bags and Sand Bagging	10	SWP-RockBags	2
	drmprd	KeyShtMisc	Key Sheet Items (Miscellaneous)	0	0 / Continuous	2
X	drmprd	LARWLine	Limited Access Right of Way Lines	4	RW-LimitedAccess-Proposed	2
X	drmprd	LARWLine_ep	Limited Access Right of Way Lines (Existing)	4	RW-LimitedAccess-Existing	1
	drmprd	LeaderLine_dp	Leader Line and Terminator with Text	0	0 / Continuous	1
	drmprd	Logo_dp	Consultant Engineer of Record Logo	0	0 / Continuous	1
X	drmprd	Manhole	Manhole (Drainage and Unknown)	10	0 / Continuous	2
	drmprd	MatchLines_dp	Match Lines with Text, Arrows for Station Notations	1	0 / Continuous	2
X	drmprd	MES	Mitered End Section	10	0 / Continuous	2
	drmprd	Miscellaneous0	Undefined Proposed Item - Color Blue Weight 0	1	0 / Continuous	0
	drmprd	Miscellaneous1	Undefined Proposed Item - Color Blue Weight 1	1	0 / Continuous	1
	drmprd	Miscellaneous2	Undefined Proposed Item - Color Blue Weight 2	1	0 / Continuous	2
	drmprd	Miscellaneous3	Undefined Proposed Item - Color Green Weight 0	2	0 / Continuous	0
	drmprd	Miscellaneous4	Undefined Proposed Item - Color Green Weight 1	2	0 / Continuous	1
	drmprd	Miscellaneous5	Undefined Proposed Item - Color Green Weight 2	2	0 / Continuous	2
	drmprd	Miscellaneous6	Undefined Proposed Item - Color Red Weight 0	3	0 / Continuous	0
	drmprd	Miscellaneous7	Undefined Proposed Item - Color Red Weight 1	3	0 / Continuous	1
	drmprd	Miscellaneous8	Undefined Proposed Item - Color Red Weight 2	3	0 / Continuous	2
	drmprd	Miscellaneous9	Undefined Proposed Item - Color Red Weight 3	3	0 / Continuous	3
	drmprd	NonPlottingEle_dp	Non-Plotting Items - Construction Elements, Type 66 Elements, Etc.	4	0 / Continuous	0
	drmprd	NorthArw_dp	North Arrows	0	0 / Continuous	2
	drmprd	PayItem_dp	Pay Item Number Label Elements	4	0 / Continuous	2
	drmprd	Permit1	Permit 1 Wetlands, Mitigation Sites, Planting Areas	1	0 / Continuous	1
	drmprd	Permit2	Permit 2 Wetlands, Mitigation Sites, Planting Areas	2	0 / Continuous	1
	drmprd	Permit3	Permit 3 Wetlands, Mitigation Sites, Planting Areas	4	0 / Continuous	1
X	drmprd	PipeCulvert	Pipe Culvert in Plan	10	2 / DGN2	2
	drmprd	PipeCulvert_ep	Pipe Culvert (Existing)	10	3 / DGN3	1
X	drmprd	PipeCulvert_pr	Pipe Culvert in Profile	10	0 / Continuous	2
X	drmprd	PipeCulvert_px	Pipe Culvert on Cross Section View	10	0 / Continuous	2
X	drmprd	PipeCulvertCD	Pipe Culvert Cross Drain	10	0 / Continuous	2
X	drmprd	PipeCulvertGD	Pipe Culvert Gutter Drain	10	0 / Continuous	2
X	drmprd	PipeCulvertSD	Pipe Culvert Side Drain	10	0 / Continuous	2
X	drmprd	PipeCulvertSS	Pipe Culvert Storm Sewer	10	0 / Continuous	2
X	drmprd	PlotBorder_dp	Plot Border	3	0 / Continuous	0
	drmprd	PointLocator_ep	Point Locator Symbol (Existing)	4	0 / Continuous	0
X	drmprd	Pond_px	Pond Lines on Cross Sections	2	0 / Continuous	2
X	drmprd	PondSideSlope	Pond Side Slope	0	0 / Continuous	2
X	drmprd	PropertyLine_ep	Property Lines (Existing)	3	0 / Continuous	0



Critical	Rule	Level Name	Level Description	ByLevel Color	ByLevelStyle / Linetype	ByLevel Weight
	drmprd	ReferencePt_dp	Survey and Construction Reference Point Details and Elements	4	0 / Continuous	2
X	drmprd	RetentionArea	Retention Area	2	0 / Continuous	2
X	drmprd	RipRap	Rip Rap, Rubble	4	0 / Continuous	2
X	drmprd	RockGravelStone	Rock, Gravel, Stone, Boulders, Etc.	1	0 / Continuous	2
X	drmprd	RWLine	Right of Way Lines	4	RW-Proposed	2
X	drmprd	RWLine_ep	Right of Way Lines (Existing)	3	RW-Existing	1
	drmprd	Scale_dp	Bar Scale, Scale Label Elements	0	0 / Continuous	2
	drmprd	Scratch1_dp	Scratch Level for Temporary or Informational Items	4	0 / Continuous	0
	drmprd	Scratch2_dp	Scratch Level for Temporary or Informational Items	5	0 / Continuous	0
	drmprd	ScratchEle_dp	Scratch Level for Draft Elements, Temporary Elements, Etc. (DO NOT PLOT)	3	0 / Continuous	0
	drmprd	ScratchEle2_dp	Scratch Level for Draft Elements, Temporary Elements, Etc. (DO NOT PLOT)	4	0 / Continuous	0
101	drmprd	SedimentBarrier	Synthetic Bales and Staked Silt Fences	10	SWP-HayBales	2
101	drmprd	SedimentBarrier	Synthetic Bales and Staked Silt Fences	10	SWP-SiltFence	2
X	drmprd	SedimentBasin	Sediment Basin Index 101	10	0 / Continuous	2
X	drmprd	SedimentBasin_ep	Sediment Basin Index 101 (Existing)	10	3 / DGN3	1
	drmprd	SheetBorder_dp	Sheet Border	1	0 / Continuous	4
	drmprd	SheetLines_dp	Sheet Lines	1	0 / Continuous	2
	drmprd	SheetLinesMisc1_dp	Sheet Lines	1	0 / Continuous	0
	drmprd	SheetLinesMisc2_dp	Sheet Lines	2	0 / Continuous	2
	drmprd	SheetLinesMisc3_dp	Sheet Lines	3	0 / Continuous	2
	drmprd	SheetLinesMisc4_dp	Sheet Lines	4	0 / Continuous	2
X	drmprd	SlideGate	Slide Gate	10	0 / Continuous	2
X	drmprd	Slopes	Slopes (Top, Bottom)	9	3 / DGN3	0
X	drmprd	SlopeStakes1	Slope Stakes 1	4	1 / DGN1	3
X	drmprd	SlopeStakes2	Slope Stakes 2	1	1 / DGN1	3
X	drmprd	SlottedDrainPipe	Slotted Drain Pipe	10	0 / Continuous	1
X	drmprd	SlottedStormSewer	Storm Sewer (Slotted or Perforated)	10	0 / Continuous	2
	drmprd	SpecialDetails	Special Details	6	0 / Continuous	1
	drmprd	SpecialDetails_px	Special Details Cross Sections	6	0 / Continuous	1
X	drmprd	Spillway	Spillway/ Flume/ Slope Drain	10	0 / Continuous	2
	drmprd	StationTicL_dp	Station Tic Marks (Large) and Text	0	0 / Continuous	2
	drmprd	StationTicS_dp	Station Tic Marks (Small) and Text	0	0 / Continuous	2
X	drmprd	StormSewer	Storm Sewer (All Types), Drain Pipes and Spouts	10	0 / Continuous	2
	drmprd	SumBoxBorder_dp	Summary Boxes Borders	4	0 / Continuous	3
	drmprd	SumBoxLines_dp	Summary Boxes Lines and Miscellaneous Items	4	0 / Continuous	1
	drmprd	SumBoxLinesMin_dp	Summary Boxes Lines Minor Line and Miscellaneous Items	4	0 / Continuous	0
	drmprd	Tables_dp	Data Tables and All Autodesk Tables	0	0 / Continuous	1
X	drmprd	TerrainLine_ex	Ground Line for Multiline on Cross Sections (Existing)	5	0 / Continuous	1
	drmprd	TextAlert	Text - Alert Label to Highlight a Problem	3	0 / Continuous	2
	drmprd	TextBLStation	Text - B/L Station and Tics	0	0 / Continuous	2
	drmprd	TextConstEle	Text - Construction Element	0	0 / Continuous	1
	drmprd	TextCurveData	Text - Curve Data Note	0	0 / Continuous	2
	drmprd	TextDetails	Text - Detail Notes	4	0 / Continuous	2
	drmprd	TextDrainInvElev_ep	Text - Drainage Invert Elevation (Existing)	0	0 / Continuous	1
	drmprd	TextDrainLabel_ep	Text - Drainage (Existing)	0	0 / Continuous	1
	drmprd	TextElevLabel	Text - Elevation Labels	4	0 / Continuous	0

Critical	Rule	Level Name	Level Description	ByLevel Color	ByLevelStyle / Linetype	ByLevel Weight
	drmprd	TextLabel	Text - Label	0	0 / Continuous	2
	drmprd	TextLandscape	Text - Landscape Labels	0	0 / Continuous	1
	drmprd	TextMajor	Text - Major	0	0 / Continuous	5
	drmprd	TextMinor	Text - Minor	0	0 / Continuous	0
	drmprd	TextMisc	Text - Miscellaneous	0	0 / Continuous	1
	drmprd	TextNotes	Text - Notes	4	0 / Continuous	1
	drmprd	TextProfLabel	Text - Profile, Horizontal and Vertical Axis Labels	0	0 / Continuous	2
	drmprd	TextProjLabel	Text - Begin and End Project Label with Leader Lines	1	0 / Continuous	2
	drmprd	TextPtLabel	Text - Point Labels	4	0 / Continuous	0
	drmprd	TextShtNo	Text - Sheet Number	0	0 / Continuous	2
	drmprd	TextSubUtilLabel_ep	Text - Subsurface Utilities (Existing)	0	0 / Continuous	1
	drmprd	TextSurveyLabel	Text - Survey Labels	0	0 / Continuous	0
	drmprd	TextTables	Text - Key Sheet Indexes and Table Data	4	0 / Continuous	2
	drmprd	TextTitle	Text - Title	0	0 / Continuous	3
	drmprd	TextTopoLabel_ep	Text - Topography (Existing)	0	0 / Continuous	1
	drmprd	TextUtilLabel_ep	Text - Utilities (Existing)	0	0 / Continuous	1
	drmprd	TextXSElev	Text - Cross Section Elevations	2	0 / Continuous	1
X	drmprd	Trench	Storm Sewer Trench	10	0 / Continuous	2
X	drmprd	TurbidityBarrier1	Turbidity Barrier 1 (Floating)	10	SWP-TurbidityBarrier-Type1	2
	drmprd	TurbidityBarrier1_ep	Turbidity Barrier 1 (Floating) (Existing)	10	1 / DGN1	2
X	drmprd	TurbidityBarrier2	Turbidity Barrier 2 (Staked)	10	SWP-TurbidityBarrier-Type2	2
	drmprd	TurbidityBarrier2_ep	Turbidity Barrier 2 (Staked) (Existing)	10	1 / DGN1	2
X	drmprd	UnderDrain	Underdrains (All Types)	10	0 / Continuous	2
X	drmprd	UnderDrainOP	Underdrains Outlet Pipes	10	0 / Continuous	2
	drmprd	Viewport	Viewport (For AutoCAD Use)	3	0 / Continuous	0
	drmprd	Wetland	Wetland Boundary	2	RD-Wetland-Proposed	1
	drmprd	Xreference01_dp	Reference Files (For AutoCAD Use)	0	0 / Continuous	1
	drmprd	Xreference02_dp	Reference Files (For AutoCAD Use)	0	0 / Continuous	1
	drmprd	Xreference03_dp	Reference Files (For AutoCAD Use)	0	0 / Continuous	1
	drmprd	Xreference04_dp	Reference Files (For AutoCAD Use)	0	0 / Continuous	1
	drmprd	XSCell	GEOPAK Cross Section Cell/Block and Profile Cell/Block	8	0 / Continuous	1
X	drmprd	XSExtendGrdLine_ex	Cross Section Extend Ground Lines (Existing)	21	2 / DGN2	1
X	drmprd	XSGrdLine_ex	Cross Section Ground Lines (Existing)	2	2 / DGN2	1
X	drmprd	XSGrdLine_px	Cross Section Roadway Ground Lines	1	0 / Continuous	2
X	drmprd	YardDrain	Yard Drain	10	3 / DGN3	1

## DRPRRD - Drainage Proposed

Critical	Rule	Level Name	Level Description	ByLevel Color	ByLevelStyle / Linetype	ByLevel Weight
	drprrd	ActivePointCell_dp	Active Point Cell	4	0 / Continuous	10
	drprrd	AdhocPoint_dp	Adhoc Points Placed by SheetInfo	0	4 / DGN4	0
X	drprrd	ArtificialCovering	Artificial Coverings	10	0 / Continuous	2
X	drprrd	Berm	Berm (Top, Front, or Back)	10	0 / Continuous	2
	drprrd	BoundaryLineImp	Boundary Lines - Impervious	11	0 / Continuous	2
	drprrd	BoundaryLineP	Boundary Lines - Pervious	9	0 / Continuous	2
X	drprrd	BoxCulvert	Box Culvert	10	0 / Continuous	2
X	drprrd	BuildingRes1	Boundaries of Single Family Residential Buildings	1	0 / Continuous	2
X	drprrd	BuildingRes2	Boundaries of Multi-Family Residential Buildings	1	0 / Continuous	2
X	drprrd	Canal	Canal	7	0 / Continuous	1
X	drprrd	CatchBasin	Catch Basin	10	0 / Continuous	2
	drprrd	CLConst_dp	Center Line of Construction	0	0 / Continuous	2
	drprrd	ClipBorder_dp	CLIP Border and Civil 3D View Frame	3	0 / Continuous	0
	drprrd	ClipDrawingBound_dp	CLIP Drawing Boundary	3	3 / DGN3	0
	drprrd	COGO_dp	COGO Information	3	0 / Continuous	1
	drprrd	ConstLines	Construction Lines and References	1	0 / Continuous	0
	drprrd	ConstLines_pm	Construction Lines	4	0 / Continuous	0
X	drprrd	DesiltingPipes	DesiltingDe-silting Pipes	10	0 / Continuous	2
	drprrd	DimLines_dp	Dimension Lines, Corresponding Terminators, Equation Lines	0	0 / Continuous	1
X	drprrd	Ditch	Ditch Top	7	6 / DGN6	1
X	drprrd	DitchBot	Ditch Bottom	10	0 / Continuous	2
	drprrd	DitchProfLt_er	Ditch Profile Left (Existing)	8	3 / DGN3	1
	drprrd	DitchProfLt_pr	Ditch Profile Left	8	0 / Continuous	1
	drprrd	DitchProfMdn_er	Ditch Profile Median (Existing)	10	3 / DGN3	1
	drprrd	DitchProfMdn_pr	Ditch Profile Median	10	0 / Continuous	1
	drprrd	DitchProfRt_er	Ditch Profile Right (Existing)	9	3 / DGN3	1
	drprrd	DitchProfRt_pr	Ditch Profile Right	9	0 / Continuous	1
	drprrd	DrainAlert_px	Alert Symbology for Structural Elements on Cross Sections	3	0 / Continuous	2
	drprrd	DrainDivideArw	Drainage Divide Arrow	0	0 / Continuous	1
	drprrd	DrainDivides00	Drainage Divides	10	2 / DGN2	4
	drprrd	DrainDivides00_ep	Drainage Divides (Existing)	9	2 / DGN2	4
	drprrd	DrainDivides01	Drainage Divides	10	2 / DGN2	4
	drprrd	DrainDivides01_ep	Drainage Divides (Existing)	9	2 / DGN2	4
	drprrd	DrainDivides02	Drainage Divides	10	2 / DGN2	4
	drprrd	DrainDivides02_ep	Drainage Divides (Existing)	9	2 / DGN2	4
	drprrd	DrainDivides03	Drainage Divides	10	2 / DGN2	4
	drprrd	DrainDivides03_ep	Drainage Divides (Existing)	9	2 / DGN2	4
	drprrd	DrainDivides04	Drainage Divides	10	2 / DGN2	4
	drprrd	DrainDivides04_ep	Drainage Divides (Existing)	9	2 / DGN2	4
	drprrd	DrainDivides05	Drainage Divides	10	2 / DGN2	4
	drprrd	DrainDivides05_ep	Drainage Divides (Existing)	9	2 / DGN2	4
	drprrd	DrainDivides06	Drainage Divides	10	2 / DGN2	4
	drprrd	DrainDivides06_ep	Drainage Divides (Existing)	9	2 / DGN2	4
	drprrd	DrainDivides07	Drainage Divides	10	2 / DGN2	4
	drprrd	DrainDivides07_ep	Drainage Divides (Existing)	9	2 / DGN2	4
	drprrd	DrainDivides08	Drainage Divides	10	2 / DGN2	4

Critical	Rule	Level Name	Level Description	ByLevel Color	ByLevelStyle / Linetype	ByLevel Weight
	drprdd	DrainDivides08_ep	Drainage Divides (Existing)	9	2 / DGN2	4
	drprdd	DrainDivides09	Drainage Divides	10	2 / DGN2	4
	drprdd	DrainDivides09_ep	Drainage Divides (Existing)	9	2 / DGN2	4
	drprdd	DrainMisc	Drainage Items (Miscellaneous)	10	0 / Continuous	1
	drprdd	DrainMisc_pm	Drainage Items (Proposed Model) (Miscellaneous)	10	0 / Continuous	1
X	drprdd	DrainStruct	Drainage Structure in Plan	10	2 / DGN2	2
X	drprdd	DrainStruct_pr	Drainage Structures (All Types)	10	0 / Continuous	2
X	drprdd	EaseLicLine	Easement License Agreement Line	5	6 / DGN6	0
X	drprdd	EasePerpLine	Easement Lines Perpetual	4	RW-PerpetualEasement	1
X	drprdd	EaseTempLine	Easement Lines Temporary	6	RW-TemporaryEasement	0
X	drprdd	EdgeDrain	Edge Drain, Material and Outlet Pipe	10	0 / Continuous	2
X	drprdd	Endwall	Endwall (All Types)	10	0 / Continuous	2
X	drprdd	Fence	Fence, Sand Fence	6	RD-Fence	1
X	drprdd	FES	Flared End Sections	10	0 / Continuous	2
X	drprdd	FlapGate	Flap Gates	10	0 / Continuous	2
X	drprdd	FlowLine	Flow Line	10	0 / Continuous	2
	drprdd	FlowLine_pr	Flow Line (Roadway Profile View)	0	0 / Continuous	2
X	drprdd	FlowPaths	Time of Concentration Flow Paths	10	1 / DGN1	1
X	drprdd	FrenchDrain	French Drain	10	0 / Continuous	2
X	drprdd	Gabions	Gabion Baskets or Mats	10	0 / Continuous	2
X	drprdd	Gabions_ep	Gabion Baskets or Mats (Existing)	10	1 / DGN1	2
X	drprdd	GovTwpRgeLine_ep	Township / Range Lines (Existing)	10	RW-TownshipRange	2
	drprdd	GPKDrBack_dp	Back Point on Drainage Cells	2	2 / DGN2	2
	drprdd	GPKDrBottom_dp	Bottom Point on Drainage Cells	3	3 / DGN3	2
	drprdd	GPKDrCellIns_dp	Cell Insertion Point on Drainage Cells	4	4 / DGN4	2
	drprdd	GPKDrCentroid_dp	Point on Centroid for Drainage	7	7 / DGN7	2
	drprdd	GPKDrElv	Location Point for Drainage Cells	5	5 / DGN5	2
	drprdd	GPKDrFront_dp	Front Point on Drainage Cells	1	1 / DGN1	2
	drprdd	GPKDrPipe_dp	Point on Drainage Pipe	6	6 / DGN6	2
	drprdd	GPKDrPipeCir_dp	Point on Pipe Circular	6	6 / DGN6	0
	drprdd	GradeLine_er	Grade Line Profile (Existing)	2	2 / DGN2	1
	drprdd	GradeLine_pr	Grade Line Profile	5	0 / Continuous	2
	drprdd	GradeLineCtr_dp	Grade Line Profile Center (Shown in Plan View)	5	0 / Continuous	0
	drprdd	GradeLineCtr_pr	Grade Line Profile Center	5	0 / Continuous	2
	drprdd	GradeLineLt_dp	Grade Line Profile Left (Shown in Plan View)	1	0 / Continuous	0
	drprdd	GradeLineLt_er	Grade Line Profile Left (Existing)	1	2 / DGN2	1
	drprdd	GradeLineLt_pr	Grade Line Profile Left	1	0 / Continuous	2
	drprdd	GradeLineRt_dp	Grade Line Profile Right (Shown in Plan View)	4	0 / Continuous	0
	drprdd	GradeLineRt_er	Grade Line Profile Right (Existing)	4	2 / DGN2	1
	drprdd	GradeLineRt_pr	Grade Line Profile Right	4	0 / Continuous	2
	drprdd	GradeSecPat	Grade Section Patterns	0	0 / Continuous	0
	drprdd	ImageAttachment_dp	Image Attachments	0	0 / Continuous	0
X	drprdd	InletBottomJ	Inlet Bottom Type J	10	0 / Continuous	1
X	drprdd	InletBottomP	Inlet Bottom Type P	10	0 / Continuous	1
X	drprdd	InletClosedFlume	Closed Flume Inlet	10	0 / Continuous	2
X	drprdd	InletCurb	Curb Inlet (All Types)	10	0 / Continuous	2
X	drprdd	InletDBI	Ditch Bottom Inlet (All Types)	10	0 / Continuous	2
X	drprdd	InletGutter	Gutter Inlet (All Types)	10	0 / Continuous	2

Critical	Rule	Level Name	Level Description	ByLevel Color	ByLevelStyle / Linetype	ByLevel Weight
X	drprdd	InletMedian	Median Barrier Inlet	10	0 / Continuous	2
X	drprdd	InletProt	Rock Bags and Sand Bagging	10	SWP-RockBags	2
X	drprdd	LARWLine	Limited Access Right of Way Lines	4	RW-LimitedAccess-Proposed	2
X	drprdd	LARWLine_ep	Limited Access Right of Way Lines (Existing)	4	RW-LimitedAccess-Existing	1
	drprdd	LeaderLine_dp	Leader Line and Terminator with Text	0	0 / Continuous	1
X	drprdd	Manhole	Manhole (Drainage and Unknown)	10	0 / Continuous	2
X	drprdd	MES	Mitered End Section	10	0 / Continuous	2
	drprdd	Miscellaneous0	Undefined Proposed Item - Color Blue Weight 0	1	0 / Continuous	0
	drprdd	Miscellaneous1	Undefined Proposed Item - Color Blue Weight 1	1	0 / Continuous	1
	drprdd	Miscellaneous2	Undefined Proposed Item - Color Blue Weight 2	1	0 / Continuous	2
	drprdd	Miscellaneous3	Undefined Proposed Item - Color Green Weight 0	2	0 / Continuous	0
	drprdd	Miscellaneous4	Undefined Proposed Item - Color Green Weight 1	2	0 / Continuous	1
	drprdd	Miscellaneous5	Undefined Proposed Item - Color Green Weight 2	2	0 / Continuous	2
	drprdd	Miscellaneous6	Undefined Proposed Item - Color Red Weight 0	3	0 / Continuous	0
	drprdd	Miscellaneous7	Undefined Proposed Item - Color Red Weight 1	3	0 / Continuous	1
	drprdd	Miscellaneous8	Undefined Proposed Item - Color Red Weight 2	3	0 / Continuous	2
	drprdd	Miscellaneous9	Undefined Proposed Item - Color Red Weight 3	3	0 / Continuous	3
	drprdd	NonPlottingEle_dp	Non-Plotting Items - Construction Elements, Type 66 Elements, Etc.	4	0 / Continuous	0
	drprdd	NorthArw_dp	North Arrows	0	0 / Continuous	2
	drprdd	PayItem_dp	Pay Item Number Label Elements	4	0 / Continuous	2
	drprdd	Permit1	Permit 1 Wetlands, Mitigation Sites, Planting Areas	1	0 / Continuous	1
	drprdd	Permit2	Permit 2 Wetlands, Mitigation Sites, Planting Areas	2	0 / Continuous	1
	drprdd	Permit3	Permit 3 Wetlands, Mitigation Sites, Planting Areas	4	0 / Continuous	1
X	drprdd	PipeCulvert	Pipe Culvert in Plan	10	2 / DGN2	2
	drprdd	PipeCulvert_ep	Pipe Culvert (Existing)	10	3 / DGN3	1
X	drprdd	PipeCulvert_ex	Pipe Culvert in Cross Sections (Existing)	10	3 / DGN3	1
X	drprdd	PipeCulvert_pr	Pipe Culvert in Profile	10	0 / Continuous	2
X	drprdd	PipeCulvert_px	Pipe Culvert on Cross Section View	10	0 / Continuous	2
X	drprdd	PipeCulvertCD	Pipe Culvert Cross Drain	10	0 / Continuous	2
X	drprdd	PipeCulvertGD	Pipe Culvert Gutter Drain	10	0 / Continuous	2
X	drprdd	PipeCulvertSD	Pipe Culvert Side Drain	10	0 / Continuous	2
X	drprdd	PipeCulvertSS	Pipe Culvert Storm Sewer	10	0 / Continuous	2
	drprdd	PointLocator_ep	Point Locator Symbol (Existing)	4	0 / Continuous	0
X	drprdd	PondSideSlope	Pond Side Slope	0	0 / Continuous	2
X	drprdd	PropertyLine_ep	Property Lines (Existing)	3	0 / Continuous	0
	drprdd	ReferencePt_dp	Survey and Construction Reference Point Details and Elements	4	0 / Continuous	2
X	drprdd	RetentionArea	Retention Area	2	0 / Continuous	2
X	drprdd	RipRap	Rip Rap, Rubble	4	0 / Continuous	2
X	drprdd	RockGravelStone	Rock, Gravel, Stone, Boulders, Etc.	1	0 / Continuous	2
X	drprdd	RWLine	Right of Way Lines	4	RW-Proposed	2
X	drprdd	RWLine_ep	Right of Way Lines (Existing)	3	RW-Existing	1
	drprdd	Scale_dp	Bar Scale, Scale Label Elements	0	0 / Continuous	2
	drprdd	Scratch1_dp	Scratch Level for Temporary or Informational Items	4	0 / Continuous	0
	drprdd	Scratch2_dp	Scratch Level for Temporary or Informational Items	5	0 / Continuous	0
	drprdd	ScratchEle_dp	Scratch Level for Draft Elements, Temporary Elements, Etc. (DO NOT PLOT)	3	0 / Continuous	0
	drprdd	ScratchEle2_dp	Scratch Level for Draft Elements, Temporary Elements, Etc. (DO NOT PLOT)	4	0 / Continuous	0
101	drprdd	SedimentBarrier	Synthetic Bales and Staked Silt Fences	10	SWP-HayBales	2
101	drprdd	SedimentBarrier	Synthetic Bales and Staked Silt Fences	10	SWP-SiltFence	2

Critical	Rule	Level Name	Level Description	ByLevel Color	ByLevelStyle / Linetype	ByLevel Weight
X	drprrd	SedimentBasin	Sediment Basin Index 101	10	0 / Continuous	2
X	drprrd	SedimentBasin_ep	Sediment Basin Index 101 (Existing)	10	3 / DGN3	1
X	drprrd	SlideGate	Slide Gate	10	0 / Continuous	2
X	drprrd	Slopes	Slopes (Top, Bottom)	9	3 / DGN3	0
	drprrd	Slopes_ep	Natural Slopes, Levees, Dikes, Dams, Embankment (Top or Bottom) (Existing)	9	3 / DGN3	0
X	drprrd	SlopeStakes1	Slope Stakes 1	4	1 / DGN1	3
X	drprrd	SlopeStakes2	Slope Stakes 2	1	1 / DGN1	3
X	drprrd	SlottedDrainPipe	Slotted Drain Pipe	10	0 / Continuous	1
X	drprrd	SlottedStormSewer	Storm Sewer (Slotted or Perforated)	10	0 / Continuous	2
X	drprrd	Spillway	Spillway/ Flume/ Slope Drain	10	0 / Continuous	2
	drprrd	StationTicL_dp	Station Tic Marks (Large) and Text	0	0 / Continuous	2
	drprrd	StationTicS_dp	Station Tic Marks (Small) and Text	0	0 / Continuous	2
X	drprrd	StormSewer	Storm Sewer (All Types), Drain Pipes and Spouts	10	0 / Continuous	2
	drprrd	Tables_dp	Data Tables and All Autodesk Tables	0	0 / Continuous	1
	drprrd	TextAlert	Text - Alert Label to Highlight a Problem	3	0 / Continuous	2
	drprrd	TextBLStation	Text - B/L Station and Tics	0	0 / Continuous	2
	drprrd	TextConstEle	Text - Construction Element	0	0 / Continuous	1
	drprrd	TextCurveData	Text - Curve Data Note	0	0 / Continuous	2
	drprrd	TextDetails	Text - Detail Notes	4	0 / Continuous	2
	drprrd	TextDrainInvElev_ep	Text - Drainage Invert Elevation (Existing)	0	0 / Continuous	1
	drprrd	TextDrainLabel_ep	Text - Drainage (Existing)	0	0 / Continuous	1
	drprrd	TextElevLabel	Text - Elevation Labels	4	0 / Continuous	0
	drprrd	TextLabel	Text - Label	0	0 / Continuous	2
	drprrd	TextLandscape	Text - Landscape Labels	0	0 / Continuous	1
	drprrd	TextMajor	Text - Major	0	0 / Continuous	5
	drprrd	TextMinor	Text - Minor	0	0 / Continuous	0
	drprrd	TextMisc	Text - Miscellaneous	0	0 / Continuous	1
	drprrd	TextNotes	Text - Notes	4	0 / Continuous	1
	drprrd	TextProfLabel	Text - Profile, Horizontal and Vertical Axis Labels	0	0 / Continuous	2
	drprrd	TextProjLabel	Text - Begin and End Project Label with Leader Lines	1	0 / Continuous	2
	drprrd	TextPtLabel	Text - Point Labels	4	0 / Continuous	0
	drprrd	TextShtNo	Text - Sheet Number	0	0 / Continuous	2
	drprrd	TextSubUtilLabel_ep	Text - Subsurface Utilities (Existing)	0	0 / Continuous	1
	drprrd	TextSurveyLabel	Text - Survey Labels	0	0 / Continuous	0
	drprrd	TextTables	Text - Key Sheet Indexes and Table Data	4	0 / Continuous	2
	drprrd	TextTitle	Text - Title	0	0 / Continuous	3
	drprrd	TextTopoLabel_ep	Text - Topography (Existing)	0	0 / Continuous	1
	drprrd	TextUtilLabel_ep	Text - Utilities (Existing)	0	0 / Continuous	1
	drprrd	TextXSElev	Text - Cross Section Elevations	2	0 / Continuous	1
X	drprrd	Trench	Storm Sewer Trench	10	0 / Continuous	2
X	drprrd	TurbidityBarrier1	Turbidity Barrier 1 (Floating)	10	SWP-TurbidityBarrier-Type1	2
	drprrd	TurbidityBarrier1_ep	Turbidity Barrier 1 (Floating) (Existing)	10	1 / DGN1	2
X	drprrd	TurbidityBarrier2	Turbidity Barrier 2 (Staked)	10	SWP-TurbidityBarrier-Type2	2
	drprrd	TurbidityBarrier2_ep	Turbidity Barrier 2 (Staked) (Existing)	10	1 / DGN1	2
X	drprrd	UnderDrain	Underdrains (All Types)	10	0 / Continuous	2
X	drprrd	UnderDrainOP	Underdrains Outlet Pipes	10	0 / Continuous	2
	drprrd	Viewport	Viewport (For AutoCAD Use)	3	0 / Continuous	0
	drprrd	Wetland	Wetland Boundary	2	RD-Wetland-Proposed	1

Critical	Rule	Level Name	Level Description	ByLevel Color	ByLevelStyle / Linetype	Bylevel Weight
	drprdd	Xreference01_dp	Reference Files (For AutoCAD Use)	0	0 / Continuous	1
	drprdd	Xreference02_dp	Reference Files (For AutoCAD Use)	0	0 / Continuous	1
	drprdd	Xreference03_dp	Reference Files (For AutoCAD Use)	0	0 / Continuous	1
	drprdd	Xreference04_dp	Reference Files (For AutoCAD Use)	0	0 / Continuous	1
	drprdd	XSCell	GEOPAK Cross Section Cell/Block and Profile Cell/Block	8	0 / Continuous	1
X	drprdd	YardDrain	Yard Drain	10	3 / DGN3	1

## DRXSRD - Drainage Cross Section

Critical	Rule	Level Name	Level Description	ByLevel Color	ByLevelStyle / Linetype	Bylevel Weight
	drxsrd	ActivePointCell_dp	Active Point Cell	4	0 / Continuous	10
	drxsrd	AdhocPoint_dp	Adhoc Points Placed by SheetInfo	0	4 / DGN4	0
	drxsrd	BaselineSurvey	Baseline Survey	0	0 / Continuous	2
X	drxsrd	Berm_px	Berm (Top, Front, or Back) on Cross Sections	10	0 / Continuous	2
X	drxsrd	Bridge_px	Bridge Component on Cross Sections - Component Property	0	0 / Continuous	2
X	drxsrd	CandG_ex	Curb and Gutter on Cross Sections (All Types) (Existing)	4	2 / DGN2	1
X	drxsrd	CandG_px	Curb and Gutter on Cross Sections (All Types)	4	0 / Continuous	2
X	drxsrd	CandGBase_px	Curb and Gutter Base on Cross Sections	3	0 / Continuous	1
X	drxsrd	CATVBur_ex	Cable TV and Miscellaneous on Cross Sections (Buried) (Existing)	6	2 / DGN2	1
X	drxsrd	CATVBur_px	Cable TV and Miscellaneous on Cross Sections (Buried)	6	0 / Continuous	1
	drxsrd	CLConst_dp	Center Line of Construction	0	0 / Continuous	2
	drxsrd	Cloud_dp	Construction Cloud	7	0 / Continuous	2
	drxsrd	COGO_dp	COGO Information	3	0 / Continuous	1
X	drxsrd	Concrete_px	Concrete Boundary Lines on Cross Sections	0	0 / Continuous	2
X	drxsrd	Conduit_ex	Conduit and Encasements on Cross Sections (Existing)	3	2 / DGN2	1
X	drxsrd	Conduit_px	Conduit and Encasements on Cross Sections	3	0 / Continuous	1
	drxsrd	ConstArea_dp	Construction Area Crosshatch	0	0 / Continuous	1
	drxsrd	ConstLimits	Construction Limits	3	RW-LimitsOfConst	2
	drxsrd	ConstLines	Construction Lines and References	1	0 / Continuous	0
	drxsrd	ConstLines_pm	Construction Lines	4	0 / Continuous	0
	drxsrd	CurveData_dp	Curve & Coordinate Data Elements Incl. PC, PT, PI Symbols	4	0 / Continuous	2
	drxsrd	CurveDataLabel_dp	Curve Data Labels PC,PI, PT	0	0 / Continuous	2
	drxsrd	DimLines_dp	Dimension Lines, Corresponding Terminators, Equation Lines	0	0 / Continuous	1
X	drxsrd	Ditch_px	Ditch Top on Cross Sections	7	0 / Continuous	2
X	drxsrd	DitchBot_px	Ditch Bottom on Cross Sections	10	0 / Continuous	2
X	drxsrd	DitchPavt_px	Ditch Pavement on Cross Sections	3	0 / Continuous	3
	drxsrd	DrainAlert_px	Alert Symbolology for Structural Elements on Cross Sections	3	0 / Continuous	2
	drxsrd	DrainMisc_ex	Drainage Elements on Cross Sections (All) (Miscellaneous) (Existing)	10	3 / DGN3	1
X	drxsrd	DrainStruct_ex	Drainage Structures on Cross Sections (All) (Existing)	10	3 / DGN3	1
X	drxsrd	DrainStruct_px	Drainage Structures and Elements on Cross Sections (Miscellaneous)	10	0 / Continuous	2
X	drxsrd	Driveway_ex	Driveway Lines on Cross Sections (Existing)	7	2 / DGN2	2
X	drxsrd	Driveway_px	Driveway Lines on Cross Sections	7	0 / Continuous	2
X	drxsrd	DrivewayBase_px	Driveway Subgrade on Cross Sections	3	0 / Continuous	2
	drxsrd	Earthwork1_px	Earthwork (Color 0) on Cross Sections	0	0 / Continuous	1
	drxsrd	Earthwork2_px	Earthwork (Color 1) on Cross Sections	1	0 / Continuous	1
	drxsrd	Earthwork3_px	Earthwork (Color 2) on Cross Sections	2	0 / Continuous	1



Critical	Rule	Level Name	Level Description	ByLevel Color	ByLevelStyle / Linetype	ByLevel Weight
	drxsrd	Earthwork4_px	Earthwork (Color 3) on Cross Sections	3	0 / Continuous	1
	drxsrd	Earthwork5_px	Earthwork (Color 4) on Cross Sections	4	0 / Continuous	1
X	drxsrd	EaseLicLine	Easement License Agreement Line	5	6 / DGN6	0
X	drxsrd	EaseLine_ep	Easement Lines (Existing)	1	RW-Easement	1
X	drxsrd	EasePerpLine_px	Easement Lines Perpetual on Cross Sections	4	RW-PerpetualEasement	12
X	drxsrd	EaseTempLine_px	Easement Lines Temporary on Cross Sections	6	RW-TemporaryEasement	0
X	drxsrd	ElecBur_ex	Electrical on Cross Sections (Buried) (Existing)	3	2 / DGN2	1
X	drxsrd	ElecBur_px	Electrical on Cross Sections (Buried)	3	0 / Continuous	1
X	drxsrd	Endwall_px	Endwall on Cross Sections	10	0 / Continuous	2
	drxsrd	ExcavationLimits_dp	Excavation Limits on Cross Sections	0	0 / Continuous	1
	drxsrd	Fence_ex	Fence Lines on Cross Sections (Existing)	6	3 / DGN3	1
X	drxsrd	Fence_px	Fence Lines on Cross Sections	6	RD-Fence	2
X	drxsrd	FES_px	Flared End Sections on Cross Sections	10	0 / Continuous	2
X	drxsrd	FOCBur_ex	Fiber Optics Cable on Cross Sections (Buried) (Existing)	6	2 / DGN2	1
X	drxsrd	FOCBur_px	Fiber Optics Cable on Cross Sections (Buried)	6	0 / Continuous	1
X	drxsrd	FOEElecBur_ex	Fiber Optics Electrical on Cross Sections (Buried) (Existing)	3	2 / DGN2	1
X	drxsrd	FOEElecBur_px	Fiber Optics Electrical on Cross Sections (Buried)	3	0 / Continuous	1
X	drxsrd	FOTBur_ex	Fiber Optics Telephone on Cross Sections (Buried) (Existing)	6	2 / DGN2	1
X	drxsrd	FOTBur_px	Fiber Optics Telephone on Cross Sections (Buried)	6	0 / Continuous	1
X	drxsrd	Gas_ex	Gas Pipe and Fittings on Cross Sections (Miscellaneous) (Existing)	4	2 / DGN2	1
X	drxsrd	Gas_px	Gas Pipe and Fittings on Cross Sections (Miscellaneous)	4	0 / Continuous	1
	drxsrd	GeotechFillPatt1	Geotechnical Fill Pattern - (Earth, Wood, Muck, Concrete, Rock, Riprap) as Defined in Project	3	0 / Continuous	0
	drxsrd	GeotechFillPatt1_px	Geotechnical Fill Pattern on Cross Sections - (Earth, Wood, Muck, Concrete, Rock, Riprap) as Defined in Project	3	0 / Continuous	0
	drxsrd	GeotechFillPatt2	Geotechnical Fill Pattern - Clay, Sand	0	1 / DGN1	0
	drxsrd	GeotechFillPatt2_px	Geotechnical Fill Pattern on Cross Sections - Clay, Sand	0	1 / DGN1	0
	drxsrd	GeotechFillPatt3	Geotechnical Fill Pattern - Shell	3	1 / DGN1	0
	drxsrd	GeotechFillPatt3_px	Geotechnical Fill Pattern on Cross Sections - Shell	3	1 / DGN1	0
	drxsrd	GeotechFillPatt4	Geotechnical Fill Pattern - Sand	4	0 / Continuous	0
	drxsrd	GeotechFillPatt4_px	Geotechnical Fill Pattern on Cross Sections - Sand	4	0 / Continuous	0
	drxsrd	GeotechFillPatt5	Geotechnical Fill Pattern - Coquina	1	0 / Continuous	1
	drxsrd	GeotechFillPatt5_px	Geotechnical Fill Pattern on Cross Sections - Coquina	1	0 / Continuous	1
	drxsrd	GeotechFillPatt6	Geotechnical Fill Pattern - Limestone	2	0 / Continuous	0
	drxsrd	GeotechFillPatt6_px	Geotechnical Fill Pattern on Cross Sections - Limestone	2	0 / Continuous	0
	drxsrd	GeotechFillPatt7	Geotechnical Fill Pattern - Gravel	6	0 / Continuous	0
	drxsrd	GeotechFillPatt7_px	Geotechnical Fill Pattern on Cross Sections - Gravel	6	0 / Continuous	0
	drxsrd	GeotechFillPatt8	Geotechnical Fill Pattern - Silt	0	0 / Continuous	1
	drxsrd	GeotechFillPatt8_px	Geotechnical Fill Pattern on Cross Sections - Silt	0	0 / Continuous	1
	drxsrd	GeotechMisc	Geotechnical Elements (Miscellaneous)	0	0 / Continuous	1
	drxsrd	GPKDrBack_dp	Back Point on Drainage Cells	2	2 / DGN2	2
	drxsrd	GPKDrBottom_dp	Bottom Point on Drainage Cells	3	3 / DGN3	2
	drxsrd	GPKDrCellIns_dp	Cell Insertion Point on Drainage Cells	4	4 / DGN4	2
	drxsrd	GPKDrCentroid_dp	Point on Centroid for Drainage	7	7 / DGN7	2
	drxsrd	GPKDrElv	Location Point for Drainage Cells	5	5 / DGN5	2
	drxsrd	GPKDrFront_dp	Front Point on Drainage Cells	1	1 / DGN1	2
	drxsrd	GPKDrPipe_dp	Point on Drainage Pipe	6	6 / DGN6	2
	drxsrd	GPKDrPipeCir_dp	Point on Pipe Circular	6	6 / DGN6	0
	drxsrd	GridMaj_dp	Grid Lines Major in Profile and Cross Section	3	0 / Continuous	1



Critical	Rule	Level Name	Level Description	ByLevel Color	ByLevelStyle / Linetype	ByLevel Weight
	drxsrd	GridMin_dp	Grid Lines Minor in Profile and Cross Section	0	0 / Continuous	0
	drxsrd	GridMinG_dp	Grid Lines Minor Sub 2 on Cross Section Sheets	20	0 / Continuous	0
	drxsrd	GridMinSub_dp	Grid Lines Minor Sub on Cross Section Sheets	20	0 / Continuous	0
X	drxsrd	Guardrail_ex	Guardrail Lines on Cross Sections (Existing)	0	2 / DGN2	2
X	drxsrd	GuardrailPanel_px	Guardrail Component Property on Cross Sections for 3D Guardrail Panels	11	0 / Continuous	1
X	drxsrd	GuardrailPost_px	Guardrail Component Property on Cross Sections for 3D Guardrail Posts	10	0 / Continuous	0
	drxsrd	ImageAttachment_dp	Image Attachments	0	0 / Continuous	0
X	drxsrd	Inlet_px	Inlets on Cross Sections	10	0 / Continuous	2
X	drxsrd	InletBottom_px	Inlet Bottom on Cross Sections (All Types)	10	0 / Continuous	2
	drxsrd	KeyShtMisc	Key Sheet Items (Miscellaneous)	0	0 / Continuous	2
X	drxsrd	LARWLine_ex	Limited Access Right of Way Lines on Cross Sections (Existing)	4	RW-LimitedAccess-Existing	1
X	drxsrd	LARWLine_px	Limited Access Right of Way Lines on Cross Sections	4	RW-LimitedAccess-Proposed	2
X	drxsrd	LateralLimits_px	Lateral Limits on Cross Sections	6	0 / Continuous	2
	drxsrd	LeaderLine_dp	Leader Line and Terminator with Text	0	0 / Continuous	1
	drxsrd	Logo_dp	Consultant Engineer of Record Logo	0	0 / Continuous	1
	drxsrd	Manhole_ex	Manhole on Cross Sections (Existing)	10	3 / DGN3	2
X	drxsrd	Manhole_px	Manhole on Cross Sections	10	0 / Continuous	2
X	drxsrd	MES_px	Mitered End Section on Cross Sections	10	0 / Continuous	2
	drxsrd	Miscellaneous0	Undefined Proposed Item - Color Blue Weight 0	1	0 / Continuous	0
	drxsrd	Miscellaneous1	Undefined Proposed Item - Color Blue Weight 1	1	0 / Continuous	1
	drxsrd	Miscellaneous2	Undefined Proposed Item - Color Blue Weight 2	1	0 / Continuous	2
	drxsrd	Miscellaneous3	Undefined Proposed Item - Color Green Weight 0	2	0 / Continuous	0
	drxsrd	Miscellaneous4	Undefined Proposed Item - Color Green Weight 1	2	0 / Continuous	1
	drxsrd	Miscellaneous5	Undefined Proposed Item - Color Green Weight 2	2	0 / Continuous	2
	drxsrd	Miscellaneous6	Undefined Proposed Item - Color Red Weight 0	3	0 / Continuous	0
	drxsrd	Miscellaneous7	Undefined Proposed Item - Color Red Weight 1	3	0 / Continuous	1
	drxsrd	Miscellaneous8	Undefined Proposed Item - Color Red Weight 2	3	0 / Continuous	2
	drxsrd	Miscellaneous9	Undefined Proposed Item - Color Red Weight 3	3	0 / Continuous	3
	drxsrd	NonPlottingEle_dp	Non-Plotting Items - Construction Elements, Type 66 Elements, Etc.	4	0 / Continuous	0
	drxsrd	Patternlines_ep	Cross Section Chain (Existing)	2	1 / DGN1	0
	drxsrd	PatternLines1_dp	Pattern Lines on Cross Sections and All Autodesk (Civil 3D) Tables	3	0 / Continuous	2
	drxsrd	PatternLines2_dp	Pattern Lines on Cross Sections Alternate for Side Streets, Critical Cross Sections or Drainage Structures	4	0 / Continuous	2
	drxsrd	PatternLines3_dp	Pattern Lines on Cross Sections Alternate for Side Streets, Critical Cross Sections or Drainage Structures	5	0 / Continuous	2
X	drxsrd	PavedMedianBase_px	Median Subgrade on Cross Sections (Paved)	3	0 / Continuous	2
	drxsrd	PavtAsphalt_ep	Asphalt Pavement Edge (Existing)	0	3 / DGN3	1
X	drxsrd	PavtAsphalt_px	Asphalt Pavement on Cross Sections and Components in Models	1	0 / Continuous	2
X	drxsrd	PavtBase_ex	Base Material on Cross Sections (All Types) (Existing)	3	3 / DGN3	1
X	drxsrd	PavtBase_px	Base Material on Cross Sections (All Types)	3	0 / Continuous	2
X	drxsrd	PavtConcrete_px	Concrete Pavement on Cross Sections and Components in Models	0	0 / Continuous	2
X	drxsrd	PavtMilling_px	Asphalt Milling Lines on Cross Sections	7	0 / Continuous	2
X	drxsrd	PavtMisc_px	Pavement on Cross Sections (Miscellaneous)	1	0 / Continuous	2
X	drxsrd	PavtOverbuild_px	Pavement Overbuild Areas on Cross Sections - Component Property	4	0 / Continuous	2
X	drxsrd	PavtOverlay_px	Pavement Overlay on Cross Sections - Component Property	1	0 / Continuous	2
X	drxsrd	PavtOverlay1_px	Pavement Overlay on Cross Sections - Component Property	14	0 / Continuous	2
X	drxsrd	PavtOverlay2_px	Pavement Overlay on Cross Sections - Component Property	7	0 / Continuous	2
X	drxsrd	PavtStabilization_px	Stabilization on Cross Sections	5	2 / DGN2	2
	drxsrd	PayItem_dp	Pay Item Number Label Elements	4	0 / Continuous	2

Critical	Rule	Level Name	Level Description	ByLevel Color	ByLevelStyle / Linetype	ByLevel Weight
	drxsrd	PipeCulvert_ep	Pipe Culvert (Existing)	10	3 / DGN3	1
X	drxsrd	PipeCulvert_ex	Pipe Culvert in Cross Sections (Existing)	10	3 / DGN3	1
X	drxsrd	PipeCulvert_pr	Pipe Culvert in Profile	10	0 / Continuous	2
X	drxsrd	PipeCulvert_px	Pipe Culvert on Cross Section View	10	0 / Continuous	2
X	drxsrd	PlotBorder_dp	Plot Border	3	0 / Continuous	0
	drxsrd	PointLocator_ep	Point Locator Symbol (Existing)	4	0 / Continuous	0
X	drxsrd	Pond_px	Pond Lines on Cross Sections	2	0 / Continuous	2
X	drxsrd	PropertyLine_ep	Property Lines (Existing)	3	0 / Continuous	0
X	drxsrd	PvtAnalysisCrown_px	Pavement Analysis Crowning on Cross Sections - Component Property	7	0 / Continuous	1
X	drxsrd	PvtAnalysisFail_px	Pavement Analysis Failure on Cross Sections - Component Property	3	0 / Continuous	1
X	drxsrd	PvtAnalysisMax_px	Pavement Analysis Acceptable Maximum Range on Cross Sections - Component Property	5	0 / Continuous	1
X	drxsrd	PvtAnalysisMin_px	Pavement Analysis Acceptable Minimum Range on Cross Sections - Component Property	4	0 / Continuous	1
X	drxsrd	PvtAnalysisOptiml_px	Pavement Analysis Optimal on Cross Sections - Component Property	2	0 / Continuous	1
X	drxsrd	Railing_px	Railing Components and Cross Sections Shapes	9	0 / Continuous	2
	drxsrd	ReferencePt_dp	Survey and Construction Reference Point Details and Elements	4	0 / Continuous	2
	drxsrd	RegionBdry_dp	Boundary Line for Regions in Corridor Design (For AutoCAD Use)	0	0 / Continuous	0
X	drxsrd	RipRap_px	Rip Rap, Rubble on Cross Sections	4	1 / DGN1	2
X	drxsrd	RumbleStrip1	Rumble Strips Continuous Array	0	PM-RumbleSolid	2
X	drxsrd	RumbleStrip2	Rumble Strips Skip Array	0	PM-RumbleSkip	2
X	drxsrd	RWLine	Right of Way Lines	4	RW-Proposed	2
X	drxsrd	RWLine_ep	Right of Way Lines (Existing)	3	RW-Existing	1
X	drxsrd	RWLine_ex	Right of Way Lines on Cross Sections (Existing)	3	RW-Existing	1
X	drxsrd	RWLine_px	Right of Way Lines on Cross Sections	4	RW-Proposed	2
X	drxsrd	SanitaryFM_ex	Force Main Lines on Cross Sections (Existing)	2	2 / DGN2	1
X	drxsrd	SanitaryFM_px	Force Main Lines on Cross Sections	2	0 / Continuous	1
X	drxsrd	SanitarySewer_ex	Sanitary Sewer on Cross Sections (Existing)	2	2 / DGN2	0
X	drxsrd	SanitarySewer_px	Sanitary Sewer on Cross Sections	2	0 / Continuous	1
X	drxsrd	SanitarySewerEff_ex	Sanitary Sewer Effluent on Cross Sections (Existing)	5	0 / Continuous	0
X	drxsrd	SanitarySewerEff_px	Sanitary Sewer Effluent on Cross Sections	5	0 / Continuous	0
	drxsrd	Scratch1_dp	Scratch Level for Temporary or Informational Items	4	0 / Continuous	0
	drxsrd	Scratch2_dp	Scratch Level for Temporary or Informational Items	5	0 / Continuous	0
	drxsrd	ScratchEle_dp	Scratch Level for Draft Elements, Temporary Elements, Etc. (DO NOT PLOT)	3	0 / Continuous	0
	drxsrd	ScratchEle2_dp	Scratch Level for Draft Elements, Temporary Elements, Etc. (DO NOT PLOT)	4	0 / Continuous	0
	drxsrd	SheetBorder_dp	Sheet Border	1	0 / Continuous	4
	drxsrd	SheetLines_dp	Sheet Lines	1	0 / Continuous	2
	drxsrd	SheetLinesMisc1_dp	Sheet Lines	1	0 / Continuous	0
	drxsrd	SheetLinesMisc2_dp	Sheet Lines	2	0 / Continuous	2
	drxsrd	SheetLinesMisc3_dp	Sheet Lines	3	0 / Continuous	2
	drxsrd	SheetLinesMisc4_dp	Sheet Lines	4	0 / Continuous	2
X	drxsrd	ShldrBase_px	Shoulder Base on Cross Sections	3	0 / Continuous	2
X	drxsrd	ShldrMilling_px	Shoulder Milling Component on Cross Sections - Component Property	7	0 / Continuous	2
X	drxsrd	ShldrOverbuild_px	Shoulder Overbuild on Cross Sections - Component Property	4	0 / Continuous	1
X	drxsrd	ShldrOverlay_px	Shoulder Overlay on Cross Sections - Component Property	1	0 / Continuous	1
X	drxsrd	ShldrPaved_px	Shoulder Lines on Cross Sections (Paved)	1	0 / Continuous	2
X	drxsrd	ShldrUnpaved_px	Shoulder Lines on Cross Sections (Unpaved)	2	0 / Continuous	2
X	drxsrd	Sidewalk_ex	Sidewalk Elements on Cross Sections (Existing)	0	2 / DGN2	1
X	drxsrd	Sidewalk_px	Sidewalk Elements on Cross Sections	0	0 / Continuous	2
	drxsrd	SidewalkBack_er	Back of Sidewalk Line Profile (Existing)	2	2 / DGN2	1

Critical	Rule	Level Name	Level Description	ByLevel Color	ByLevelStyle / Linetype	ByLevel Weight
	drxsrd	SidewalkBack_pr	Back of Sidewalk Line Profile	5	0 / Continuous	2
X	drxsrd	SidewalkBase_px	Sidewalk Subgrade on Cross Sections	3	0 / Continuous	2
X	drxsrd	Slopes_px	Slope Lines on Cross Sections	9	0 / Continuous	2
X	drxsrd	SoilBoxes_px	Soil Boxes and Borings on Cross Sections	4	0 / Continuous	1
	drxsrd	SpecialDetails_px	Special Details on Cross Sections	6	0 / Continuous	1
	drxsrd	StationTicL_dp	Station Tic Marks (Large) and Text	0	0 / Continuous	2
	drxsrd	StationTicS_dp	Station Tic Marks (Small) and Text	0	0 / Continuous	2
X	drxsrd	StreetLights_px	Street Lights on Cross Sections	3	0 / Continuous	1
	drxsrd	Structure_px	Signal and Sign Structures on Cross Sections	0	0 / Continuous	2
X	drxsrd	SubDsgn_px	Sub Design on Cross Sections Including Subbase	4	0 / Continuous	1
X	drxsrd	Subsoil_px	Subsoil or Undercut on Cross Sections	4	0 / Continuous	2
X	drxsrd	SubsoilFinal_px	Subsoil Final for Multiline on Cross Sections	18	0 / Continuous	1
X	drxsrd	SubsoilProp_px	Subsoil Proposed for Multiline on Cross Sections	8	0 / Continuous	1
	drxsrd	SumBoxBorder_dp	Summary Boxes Borders	4	0 / Continuous	3
	drxsrd	SumBoxLines_dp	Summary Boxes Lines and Miscellaneous Items	4	0 / Continuous	1
	drxsrd	SumBoxLinesMin_dp	Summary Boxes Lines Minor Line and Miscellaneous Items	4	0 / Continuous	0
	drxsrd	Tables_dp	Data Tables and All Autodesk Tables	0	0 / Continuous	1
X	drxsrd	TeleBur_ex	Telephone on Cross Sections (Buried) (Miscellaneous) (Existing)	6	2 / DGN2	1
X	drxsrd	TeleBur_px	Telephone on Cross Sections (Buried) (Miscellaneous)	6	0 / Continuous	1
X	drxsrd	TemplateBottom_px	Bottom of Template for Multiline on Cross Sections	6	0 / Continuous	1
X	drxsrd	TemplateFinal_px	Final Template for Multiline on Cross Sections	2	0 / Continuous	1
X	drxsrd	TemplateTop_px	Top of Template for Multiline on Cross Sections	7	0 / Continuous	1
X	drxsrd	TerrainLine_ex	Ground Line for Multiline on Cross Sections (Existing)	5	0 / Continuous	1
	drxsrd	TextAlert	Text - Alert Label to Highlight a Problem	3	0 / Continuous	2
	drxsrd	TextBLStation	Text - B/L Station and Tics	0	0 / Continuous	2
	drxsrd	TextConstEle	Text - Construction Element	0	0 / Continuous	1
	drxsrd	TextCurveData	Text - Curve Data Note	0	0 / Continuous	2
	drxsrd	TextDetails	Text - Detail Notes	4	0 / Continuous	2
	drxsrd	TextDrainInvElev_ep	Text - Drainage Invert Elevation (Existing)	0	0 / Continuous	1
	drxsrd	TextDrainLabel_ep	Text - Drainage (Existing)	0	0 / Continuous	1
	drxsrd	TextElevLabel	Text - Elevation Labels	4	0 / Continuous	0
	drxsrd	TextGeotech	Text - Soil Borings and Labels	0	0 / Continuous	2
	drxsrd	TextLabel	Text - Label	0	0 / Continuous	2
	drxsrd	TextLandscape	Text - Landscape Labels	0	0 / Continuous	1
	drxsrd	TextMajor	Text - Major	0	0 / Continuous	5
	drxsrd	TextMinor	Text - Minor	0	0 / Continuous	0
	drxsrd	TextMisc	Text - Miscellaneous	0	0 / Continuous	1
	drxsrd	TextNotes	Text - Notes	4	0 / Continuous	1
	drxsrd	TextProfLabel	Text - Profile, Horizontal and Vertical Axis Labels	0	0 / Continuous	2
	drxsrd	TextPtLabel	Text - Point Labels	4	0 / Continuous	0
	drxsrd	TextShtNo	Text - Sheet Number	0	0 / Continuous	2
	drxsrd	TextSubUtilLabel_ep	Text - Subsurface Utilities (Existing)	0	0 / Continuous	1
	drxsrd	TextSurveyLabel	Text - Survey Labels	0	0 / Continuous	0
	drxsrd	TextTables	Text - Key Sheet Indexes and Table Data	4	0 / Continuous	2
	drxsrd	TextTitle	Text - Title	0	0 / Continuous	3
	drxsrd	TextTopoLabel_ep	Text - Topography (Existing)	0	0 / Continuous	1
	drxsrd	TextUtilLabel_ep	Text - Utilities (Existing)	0	0 / Continuous	1
	drxsrd	TextXSBL_dp	Text - Cross Section Baseline Labels	0	0 / Continuous	2

Critical	Rule	Level Name	Level Description	ByLevel Color	ByLevelStyle / Linetype	ByLevel Weight
	drxsrd	TextXSDrain_ex	Text - Cross Section Drainage Labels (Existing)	10	0 / Continuous	2
	drxsrd	TextXSDrain_px	Text - Cross Section Drainage Labels	10	0 / Continuous	2
	drxsrd	TextXSElev	Text - Cross Section Elevations	2	0 / Continuous	1
	drxsrd	TextXSElev_ex	Text - Cross Section Elevations (Existing)	2	0 / Continuous	1
	drxsrd	TextXSElev_px	Text - Cross Section Elevations	0	0 / Continuous	1
	drxsrd	TextXSGPKPts_dp	Text - Cross Section Points Labels	4	0 / Continuous	0
	drxsrd	TextXSNotes_dp	Text - Cross Section Notes	0	0 / Continuous	2
	drxsrd	TextXSSlope_dp	Text - Cross Section Slope Labels (rise:run format)	0	0 / Continuous	2
	drxsrd	TextXSSlopePvt_dp	Text - Cross Section Pavement Slope Labels	0	0 / Continuous	2
X	drxsrd	TrafSeparator_ex	Traffic Separator on Cross Sections (All Types) (Existing)	6	2 / DGN2	1
X	drxsrd	TrafSeparator_px	Traffic Separator on Cross Sections (All Types)	6	0 / Continuous	2
X	drxsrd	TrafSeparatorBase_px	Traffic Separator Subgrade on Cross Sections	3	0 / Continuous	2
	drxsrd	TypicalMisc	Typical Items (Miscellaneous)	0	0 / Continuous	2
	drxsrd	UtilsMisc_ex	Utility Items on Cross Sections (Miscellaneous ) (Existing)	8	2 / DGN2	1
	drxsrd	UtilsMisc_px	Utility Items on Cross Sections (Miscellaneous)	8	0 / Continuous	1
	drxsrd	Vehicle	Vehicle for Calculating Turning Radius	7	0 / Continuous	2
	drxsrd	Viewport	Viewport (For AutoCAD Use)	3	0 / Continuous	0
	drxsrd	VoidArea_dx	Void Area on Cross Sections	1	0 / Continuous	0
X	drxsrd	WallBarrier_ex	Barrier Wall on Cross Section (Existing)	6	3 / DGN3	1
X	drxsrd	WallBarrier_px	Barrier Wall on Cross Section	6	0 / Continuous	2
X	drxsrd	WallFooter_px	Wall Footer (Concrete) on Cross Sections - Component Symbolology/Material on All Wall Footers/Leveling Pads	2	0 / Continuous	1
X	drxsrd	WallGravBase_px	Gravity Wall Subgrade on Cross Sections	3	0 / Continuous	2
X	drxsrd	WallGravity_px	Gravity Wall on Cross Sections	11	0 / Continuous	2
X	drxsrd	WallMedianBase_px	Median Wall Subgrade on Cross Sections	3	0 / Continuous	2
X	drxsrd	WallRetain_px	Retaining Walls on Cross Sections	6	0 / Continuous	1
X	drxsrd	WallShldrBase_px	Shoulder Wall Subgrade on Cross Sections	3	0 / Continuous	2
X	drxsrd	Water_ex	Water on Cross Sections (Existing)	1	2 / DGN2	1
X	drxsrd	Water_px	Water on Cross Sections	1	0 / Continuous	1
X	drxsrd	WaterNP_ex	Raw Water Pipes on Cross Sections (Existing)	5	0 / Continuous	1
X	drxsrd	WaterNP_px	Raw Water Pipes on Cross Sections	5	0 / Continuous	1
	drxsrd	Wetland_ex	Wetland Boundary on Cross Sections (Existing)	2	RD-Wetland-Existing	1
	drxsrd	WetlandEdge_ep	Edge of Mangrove, Wetlands (Marsh or Swamp) (Existing)	2	RD-Wetland-Existing	0
	drxsrd	Xreference01_dp	Reference Files (For AutoCAD Use)	0	0 / Continuous	1
	drxsrd	Xreference02_dp	Reference Files (For AutoCAD Use)	0	0 / Continuous	1
	drxsrd	Xreference03_dp	Reference Files (For AutoCAD Use)	0	0 / Continuous	1
	drxsrd	Xreference04_dp	Reference Files (For AutoCAD Use)	0	0 / Continuous	1
X	drxsrd	XSBaseTop_px	Cross Section Top of Base	3	0 / Continuous	2
	drxsrd	XSCell	GEOPAK Cross Section Cell/Block and Profile Cell/Block	8	0 / Continuous	1
X	drxsrd	XSExtendGrdLine_ex	Cross Section Extend Ground Lines (Existing)	21	2 / DGN2	1
X	drxsrd	XSGrdLine_ex	Cross Section Ground Lines (Existing)	2	2 / DGN2	1
X	drxsrd	XSGrdLine_px	Cross Section Roadway Ground Lines	1	0 / Continuous	2
	drxsrd	XSMisc_ex	Cross Section Roadway Items (Miscellaneous) (Existing)	4	3 / DGN3	1
	drxsrd	XSMisc_px	Cross Section Items (Miscellaneous)	0	0 / Continuous	2
	drxsrd	XSPt_ep	Cross Section Point, Station (Existing)	2	1 / DGN1	0
	drxsrd	XSShapeDep01_dp	Cross Section Shape Dependent	11	0 / Continuous	2
	drxsrd	XSShapeDep02_dp	Cross Section Shape Dependent	12	0 / Continuous	2

Critical	Rule	Level Name	Level Description	ByLevel Color	ByLevelStyle / Linetype	ByLevel Weight
	drxsrd	XSShapeDep03_dp	Cross Section Shape Dependent	13	0 / Continuous	2
	drxsrd	XSShapeDep04_dp	Cross Section Shape Dependent	14	0 / Continuous	2
	drxsrd	XSShapeDep05_dp	Cross Section Shape Dependent	15	0 / Continuous	2
	drxsrd	XSShapeDep06_dp	Cross Section Shape Dependent	16	0 / Continuous	2
	drxsrd	XSShapeDep07_dp	Cross Section Shape Dependent	17	0 / Continuous	2
	drxsrd	XSShapeDep08_dp	Cross Section Shape Dependent	18	0 / Continuous	2
	drxsrd	XSShapeDep09_dp	Cross Section Shape Dependent	19	0 / Continuous	2
	drxsrd	XSShapeDep10_dp	Cross Section Shape Dependent	20	0 / Continuous	2
	drxsrd	XSShapeIndep01_dp	Cross Section Shape Independent	1	0 / Continuous	2
	drxsrd	XSShapeIndep02_dp	Cross Section Shape Independent	2	0 / Continuous	2
	drxsrd	XSShapeIndep03_dp	Cross Section Shape Independent	3	0 / Continuous	2
	drxsrd	XSShapeIndep04_dp	Cross Section Shape Independent	4	0 / Continuous	2
	drxsrd	XSShapeIndep05_dp	Cross Section Shape Independent	5	0 / Continuous	2
	drxsrd	XSShapeIndep06_dp	Cross Section Shape Independent	6	0 / Continuous	2
	drxsrd	XSShapeIndep07_dp	Cross Section Shape Independent	7	0 / Continuous	2
	drxsrd	XSShapeIndep08_dp	Cross Section Shape Independent	8	0 / Continuous	2
	drxsrd	XSShapeIndep09_dp	Cross Section Shape Independent	9	0 / Continuous	2
	drxsrd	XSShapeIndep10_dp	Cross Section Shape Independent	10	0 / Continuous	2
X	drxsrd	XSTypical_px	Cross Section Roadway Pavement Typical	1	0 / Continuous	2

## DSGNLD - Landscaping Design

Critical	Rule	Level Name	Level Description	ByLevel Color	ByLevelStyle / Linetype	ByLevel Weight
	dsgnld	ActivePointCell_dp	Active Point Cell	4	0 / Continuous	10
	dsgnld	AdhocPoint_dp	Adhoc Points Placed by SheetInfo	0	4 / DGN4	0
	dsgnld	BillboardDim	Billboard Dimension	0	0 / Continuous	2
	dsgnld	BillboardHt	Billboard Height	0	0 / Continuous	2
	dsgnld	BillboardLoc	Billboard Location	0	0 / Continuous	2
	dsgnld	BillboardVeg	Billboard Vegetation Area	6	1 / DGN1	1
	dsgnld	BillboardZone	Billboard View Zone	3	3 / DGN3	4
	dsgnld	ClearSight_dp	Clear Sight Lines and Limits	3	4 / DGN4	2
	dsgnld	ClearZone_dp	Clear Zone Elements	3	1 / DGN1	1
	dsgnld	COGO_dp	COGO Information	3	0 / Continuous	1
	dsgnld	ConstLines	Construction Lines and References	4	0 / Continuous	0
	dsgnld	ConstLines_pm	Construction Lines	4	0 / Continuous	0
	dsgnld	DimLines_dp	Dimension Lines, Corresponding Terminators, Equation Lines	0	0 / Continuous	1
X	dsgnld	DitchBankArea	Ditch Bank Areas for Landscape	1	0 / Continuous	1
X	dsgnld	EaseLicLine	Easement License Agreement Line	5	6 / DGN6	0
X	dsgnld	Fertilizer	Fertilizer	11	0 / Continuous	1
X	dsgnld	Flower	Flower Edge / Flower Symbol	2	0 / Continuous	1
	dsgnld	GroundCover	Groundcover Edge Symbol	2	0 / Continuous	1
	dsgnld	GroundCoverHatch	Groundcover Hatch Pattern	2	0 / Continuous	0
X	dsgnld	HandWaterArea	Hand Watering Area	1	0 / Continuous	0
X	dsgnld	HerbicideArea	Area to Receive Herbicide	5	0 / Continuous	1
	dsgnld	ImageAttachment_dp	Image Attachments	0	0 / Continuous	0
	dsgnld	LandscapeAccs	Landscape Accessories (Barbeque Grill, Bike Rack etc.)	1	0 / Continuous	1

Critical	Rule	Level Name	Level Description	ByLevel Color	ByLevelStyle / Linetype	ByLevel Weight
	dsgnld	LandscapeBllder	Landscape Boulders and Cobble	4	0 / Continuous	2
	dsgnld	LandscapeBlock	Landscape Concrete Blocks, Patterns and Walls	3	0 / Continuous	1
	dsgnld	LandscapeFills	Fills and Rock Sections	4	0 / Continuous	1
	dsgnld	LandscapeMisc	Landscaping Items (Miscellaneous)	3	0 / Continuous	2
	dsgnld	LeaderLine_dp	Leader Line and Terminator with Text	0	0 / Continuous	1
X	dsgnld	Luminaire	Luminaires (Decorative - All Types)	2	0 / Continuous	1
X	dsgnld	MaintArea	Maintenance Areas for Landscape	10	0 / Continuous	2
	dsgnld	Miscellaneous0	Undefined Proposed Item - Color Blue Weight 0	1	0 / Continuous	0
	dsgnld	Miscellaneous1	Undefined Proposed Item - Color Blue Weight 1	1	0 / Continuous	1
	dsgnld	Miscellaneous2	Undefined Proposed Item - Color Blue Weight 2	1	0 / Continuous	2
	dsgnld	Miscellaneous3	Undefined Proposed Item - Color Green Weight 0	2	0 / Continuous	0
	dsgnld	Miscellaneous4	Undefined Proposed Item - Color Green Weight 1	2	0 / Continuous	1
	dsgnld	Miscellaneous5	Undefined Proposed Item - Color Green Weight 2	2	0 / Continuous	2
	dsgnld	Miscellaneous6	Undefined Proposed Item - Color Red Weight 0	3	0 / Continuous	0
	dsgnld	Miscellaneous7	Undefined Proposed Item - Color Red Weight 1	3	0 / Continuous	1
	dsgnld	Miscellaneous8	Undefined Proposed Item - Color Red Weight 2	3	0 / Continuous	2
	dsgnld	Miscellaneous9	Undefined Proposed Item - Color Red Weight 3	3	0 / Continuous	3
X	dsgnld	MowingAreaLarge	Mowing and Maintenance Areas for Large Machine	2	0 / Continuous	2
X	dsgnld	MowingAreaSmall	Mowing and Maintenance Areas	68	0 / Continuous	1
X	dsgnld	Mulch	Mulch Area	10	0 / Continuous	1
X	dsgnld	NaturalArea	Natural Landscape Areas	30	0 / Continuous	1
X	dsgnld	NoMaint	Maintained by Others	7	0 / Continuous	1
	dsgnld	NonPlottingEle_dp	Non-Plotting Items - Construction Elements, Type 66 Elements, Etc.	4	0 / Continuous	0
	dsgnld	Pavers	Pavers - Brick and Block	5	0 / Continuous	1
	dsgnld	PayItem_dp	Pay Item Number Label Elements	4	0 / Continuous	2
X	dsgnld	PlantingArea	Plant Areas, Patterns and Boundary Elements	13	0 / Continuous	0
	dsgnld	PointLocator_ep	Point Locator Symbol (Existing)	4	0 / Continuous	0
	dsgnld	ReferencePt_dp	Survey and Construction Reference Point Details and Elements	4	0 / Continuous	2
X	dsgnld	RockGravelStone	Rock, Gravel, Stone, Boulders, Etc.	1	0 / Continuous	2
	dsgnld	Scratch1_dp	Scratch Level for Temporary or Informational Items	4	0 / Continuous	0
	dsgnld	Scratch2_dp	Scratch Level for Temporary or Informational Items	5	0 / Continuous	0
	dsgnld	ScratchEle_dp	Scratch Level for Draft Elements, Temporary Elements, Etc. (DO NOT PLOT)	3	0 / Continuous	0
	dsgnld	ScratchEle2_dp	Scratch Level for Draft Elements, Temporary Elements, Etc. (DO NOT PLOT)	4	0 / Continuous	0
X	dsgnld	Shrub	Shrubs	2	0 / Continuous	1
X	dsgnld	SlopeArea	Slope Areas for Landscape	3	0 / Continuous	1
X	dsgnld	StakingArea	Staking Area	14	0 / Continuous	1
	dsgnld	StreetFurniture	Benches, Trash Receptacles, Bus Stop Covers, etc.	4	0 / Continuous	1
X	dsgnld	StreetLights	Street Lights	2	0 / Continuous	1
	dsgnld	Tables_dp	Data Tables and All Autodesk Tables	0	0 / Continuous	1
	dsgnld	TextAlert	Text - Alert Label to Highlight a Problem	3	0 / Continuous	2
	dsgnld	TextBLStation	Text - B/L Station and Tics	0	0 / Continuous	2
	dsgnld	TextConstEle	Text - Construction Element	0	0 / Continuous	1
	dsgnld	TextCurveData	Text - Curve Data Note	0	0 / Continuous	2
	dsgnld	TextDetails	Text - Detail Notes	4	0 / Continuous	2
	dsgnld	TextDrainInvElev_ep	Text - Drainage Invert Elevation (Existing)	0	0 / Continuous	1
	dsgnld	TextDrainLabel_ep	Text - Drainage (Existing)	0	0 / Continuous	1



Critical	Rule	Level Name	Level Description	ByLevel Color	ByLevelStyle / Linetype	ByLevel Weight
	dsgnld	TextElevLabel	Text - Elevation Labels	4	0 / Continuous	0
	dsgnld	TextLabel	Text - Label	0	0 / Continuous	2
	dsgnld	TextLandscape	Text - Landscape Labels	0	0 / Continuous	1
	dsgnld	TextMajor	Text - Major	0	0 / Continuous	5
	dsgnld	TextMinor	Text - Minor	0	0 / Continuous	0
	dsgnld	TextMisc	Text - Miscellaneous	0	0 / Continuous	1
	dsgnld	TextNotes	Text - Notes	4	0 / Continuous	1
	dsgnld	TextProfLabel	Text - Profile, Horizontal and Vertical Axis Labels	0	0 / Continuous	2
	dsgnld	TextProjLabel	Text - Begin and End Project Label with Leader Lines	1	0 / Continuous	2
	dsgnld	TextPtLabel	Text - Point Labels	4	0 / Continuous	0
	dsgnld	TextShtNo	Text - Sheet Number	0	0 / Continuous	2
	dsgnld	TextSubUtilLabel_ep	Text - Subsurface Utilities (Existing)	0	0 / Continuous	1
	dsgnld	TextSurveyLabel	Text - Survey Labels	0	0 / Continuous	0
	dsgnld	TextTables	Text - Key Sheet Indexes and Table Data	4	0 / Continuous	2
	dsgnld	TextTitle	Text - Title	0	0 / Continuous	3
	dsgnld	TextTopoLabel_ep	Text - Topography (Existing)	0	0 / Continuous	1
	dsgnld	TextUtilLabel_ep	Text - Utilities (Existing)	0	0 / Continuous	1
	dsgnld	TextXSElev	Text - Cross Section Elevations	2	0 / Continuous	1
X	dsgnld	Tree	Trees, Tree Line Pattern	2	0 / Continuous	1
X	dsgnld	TreeGrate	Tree Grate	5	0 / Continuous	1
X	dsgnld	TreeMaintArea	Area Designation for Tree Sheering and Pruning	6	0 / Continuous	1
X	dsgnld	TreeProtection	Tree Protection Symbol	5	0 / Continuous	2
	dsgnld	Viewport	Viewport (For AutoCAD Use)	3	0 / Continuous	0
X	dsgnld	WeedArea	Weeding Area	11	0 / Continuous	0
	dsgnld	Xreference01_dp	Reference Files (For AutoCAD Use)	0	0 / Continuous	1
	dsgnld	Xreference02_dp	Reference Files (For AutoCAD Use)	0	0 / Continuous	1
	dsgnld	Xreference03_dp	Reference Files (For AutoCAD Use)	0	0 / Continuous	1
	dsgnld	Xreference04_dp	Reference Files (For AutoCAD Use)	0	0 / Continuous	1
	dsgnld	XSCell	GEOPAK Cross Section Cell/Block and Profile Cell/Block	8	0 / Continuous	1

## DSGNLT - Lighting Design

Critical	Rule	Level Name	Level Description	ByLevel Color	ByLevelStyle / Linetype	ByLevel Weight
	dsgnlt	ActivePointCell_dp	Active Point Cell	4	0 / Continuous	10
	dsgnlt	AdhocPoint_dp	Adhoc Points Placed by SheetInfo	0	4 / DGN4	0
	dsgnlt	Cloud_dp	Construction Cloud	7	0 / Continuous	2
	dsgnlt	COGO_dp	COGO Information	3	0 / Continuous	1
X	dsgnlt	ConduitAG	Conduit (Above Ground)	4	SG-ConduitAG-Proposed	1
X	dsgnlt	ConduitBM	Conduit – Bridge Mount	5	SG-ConduitBM-Proposed	1
X	dsgnlt	ConduitDB	Conduit – Directional Bore	2	SG-ConduitDB-Proposed	1
X	dsgnlt	ConduitJB	Conduit – Jack & Bore Under Rail	3	SG-ConduitJB-Proposed	1
X	dsgnlt	ConduitOT	Conduit – Open Trench	1	SG-ConduitOT-Proposed	1
	dsgnlt	ConstArea_dp	Construction Area Crosshatch	0	0 / Continuous	1
	dsgnlt	ConstLimits	Construction Limits	3	RW-LimitsofConst	2
	dsgnlt	ConstLines	Construction Lines and References	1	0 / Continuous	0

Critical	Rule	Level Name	Level Description	ByLevel Color	ByLevelStyle / Linetype	ByLevel Weight
	dsgnlt	ConstLines_pm	Construction Lines	4	0 / Continuous	0
	dsgnlt	DimLines_dp	Dimension Lines, Corresponding Terminators, Equation Lines	0	0 / Continuous	1
X	dsgnlt	EaseLicLine	Easement License Agreement Line	5	6 / DGN6	0
	dsgnlt	GridMaj_dp	Grid Lines Major in Profile and Cross Section	3	0 / Continuous	1
	dsgnlt	GridMin_dp	Grid Lines Minor in Profile and Cross Section	0	0 / Continuous	0
	dsgnlt	GridMinSub_dp	Grid Lines Minor Sub on Cross Section Sheets	20	0 / Continuous	0
	dsgnlt	ImageAttachment_dp	Image Attachments	0	0 / Continuous	0
X	dsgnlt	InterconCable	Cable Interconnect	1	SG-InterconCable-Proposed	1
X	dsgnlt	InterconCable_ep	Interconnect Cable (Existing)	1	SG-InterconCable-Existing	0
X	dsgnlt	JunctBoxA	Junction Boxes (Aerial)	3	0 / Continuous	1
X	dsgnlt	JunctBoxA_ep	Junction Boxes (Aerial) (Existing)	3	1 / DGN1	0
	dsgnlt	LeaderLine_dp	Leader Line and Terminator with Text	0	0 / Continuous	1
	dsgnlt	LightingMisc	Lighting Items (Miscellaneous)	4	0 / Continuous	2
X	dsgnlt	LightingSP	Lighting Service Points	0	0 / Continuous	1
X	dsgnlt	LoadCenter	Load Center	2	0 / Continuous	1
X	dsgnlt	LoadCenter_ep	Load Center (Existing)	2	5 / DGN5	0
	dsgnlt	Logo_dp	Consultant Engineer of Record Logo	0	0 / Continuous	1
X	dsgnlt	Luminaire	Luminaires (Decorative - All Types)	2	0 / Continuous	1
	dsgnlt	Miscellaneous0	Undefined Proposed Item - Color Blue Weight 0	1	0 / Continuous	0
	dsgnlt	Miscellaneous1	Undefined Proposed Item - Color Blue Weight 1	1	0 / Continuous	1
	dsgnlt	Miscellaneous2	Undefined Proposed Item - Color Blue Weight 2	1	0 / Continuous	2
	dsgnlt	Miscellaneous3	Undefined Proposed Item - Color Green Weight 0	2	0 / Continuous	0
	dsgnlt	Miscellaneous4	Undefined Proposed Item - Color Green Weight 1	2	0 / Continuous	1
	dsgnlt	Miscellaneous5	Undefined Proposed Item - Color Green Weight 2	2	0 / Continuous	2
	dsgnlt	Miscellaneous6	Undefined Proposed Item - Color Red Weight 0	3	0 / Continuous	0
	dsgnlt	Miscellaneous7	Undefined Proposed Item - Color Red Weight 1	3	0 / Continuous	1
	dsgnlt	Miscellaneous8	Undefined Proposed Item - Color Red Weight 2	3	0 / Continuous	2
	dsgnlt	Miscellaneous9	Undefined Proposed Item - Color Red Weight 3	3	0 / Continuous	3
	dsgnlt	NonPlottingEle_dp	Non-Plotting Items - Construction Elements, Type 66 Elements, Etc.	4	0 / Continuous	0
	dsgnlt	PayItem_dp	Pay Item Number Label Elements	4	0 / Continuous	2
X	dsgnlt	PlotBorder_dp	Plot Border	3	0 / Continuous	0
	dsgnlt	PointLocator_ep	Point Locator Symbol (Existing)	4	0 / Continuous	0
X	dsgnlt	PoleConc	Concrete Strain Pole	0	0 / Continuous	2
X	dsgnlt	PoleConc_ep	Concrete Strain Pole (Existing)	0	2 / DGN2	1
X	dsgnlt	PoleElec	Electrical Pole w/ Transformer	3	0 / Continuous	2
X	dsgnlt	PoleFound	Pole Foundation	0	0 / Continuous	2
X	dsgnlt	PoleLight	Light Pole	2	0 / Continuous	1
X	dsgnlt	PoleLight_ep	Light Pole (Existing)	2	2 / DGN2	1
X	dsgnlt	PoleLightHM	High Mast Light Pole	3	0 / Continuous	1
X	dsgnlt	PoleLightHM_ep	High Mast Light Pole (Existing)	2	2 / DGN2	1
	dsgnlt	PoleLightID	Light Pole Location / ID	4	0 / Continuous	1
X	dsgnlt	PoleShared	Power Pole Electric (Above Ground) Shared w/ Transformer	3	0 / Continuous	2
X	dsgnlt	PoleSteelStrain	Steel Strain Pole	0	0 / Continuous	2
X	dsgnlt	PoleSteelStrain_ep	Steel Strain Pole (Existing)	0	2 / DGN2	1
X	dsgnlt	PoleTel	Telephone Pole	6	0 / Continuous	2
X	dsgnlt	PoleUtil	Utility Pole	0	0 / Continuous	2



Critical	Rule	Level Name	Level Description	ByLevel Color	ByLevelStyle / Linetype	ByLevel Weight
X	dsgnlt	PoleWoodStrain	Wood Strain Pole	0	0 / Continuous	2
X	dsgnlt	PoleWoodStrain_ep	Wood Strain Pole (Existing)	0	2 / DGN2	1
X	dsgnlt	PullBox	Pull Boxes (All Types)	3	0 / Continuous	1
	dsgnlt	ReferencePt_dp	Survey and Construction Reference Point Details and Elements	4	0 / Continuous	2
X	dsgnlt	SawCuts	Saw Cuts	3	3 / DGN3	0
	dsgnlt	Scratch1_dp	Scratch Level for Temporary or Informational Items	4	0 / Continuous	0
	dsgnlt	Scratch2_dp	Scratch Level for Temporary or Informational Items	5	0 / Continuous	0
	dsgnlt	ScratchEle_dp	Scratch Level for Draft Elements, Temporary Elements, Etc. (DO NOT PLOT)	3	0 / Continuous	0
	dsgnlt	ScratchEle2_dp	Scratch Level for Draft Elements, Temporary Elements, Etc. (DO NOT PLOT)	4	0 / Continuous	0
	dsgnlt	SheetBorder_dp	Sheet Border	1	0 / Continuous	4
	dsgnlt	SheetLines_dp	Sheet Lines	1	0 / Continuous	2
	dsgnlt	SheetLinesMisc1_dp	Sheet Lines	1	0 / Continuous	0
	dsgnlt	SheetLinesMisc2_dp	Sheet Lines	2	0 / Continuous	2
	dsgnlt	SheetLinesMisc3_dp	Sheet Lines	3	0 / Continuous	2
	dsgnlt	SheetLinesMisc4_dp	Sheet Lines	4	0 / Continuous	2
	dsgnlt	SumBoxBorder_dp	Summary Boxes Borders	4	0 / Continuous	3
	dsgnlt	SumBoxLines_dp	Summary Boxes Lines and Miscellaneous Items	4	0 / Continuous	1
	dsgnlt	SumBoxLinesMin_dp	Summary Boxes Lines Minor Line and Miscellaneous Items	4	0 / Continuous	0
	dsgnlt	Tables_dp	Data Tables and All Autodesk Tables	0	0 / Continuous	1
	dsgnlt	TextAlert	Text - Alert Label to Highlight a Problem	3	0 / Continuous	2
	dsgnlt	TextBLStation	Text - B/L Station and Tics	0	0 / Continuous	2
	dsgnlt	TextConstEle	Text - Construction Element	0	0 / Continuous	1
	dsgnlt	TextCurveData	Text - Curve Data Note	0	0 / Continuous	2
	dsgnlt	TextDetails	Text - Detail Notes	4	0 / Continuous	2
	dsgnlt	TextDrainInvElev_ep	Text - Drainage Invert Elevation (Existing)	0	0 / Continuous	1
	dsgnlt	TextDrainLabel_ep	Text - Drainage (Existing)	0	0 / Continuous	1
	dsgnlt	TextElevLabel	Text - Elevation Labels	4	0 / Continuous	0
	dsgnlt	TextLabel	Text - Label	0	0 / Continuous	2
	dsgnlt	TextLandscape	Text - Landscape Labels	0	0 / Continuous	1
	dsgnlt	TextMajor	Text - Major	0	0 / Continuous	5
	dsgnlt	TextMinor	Text - Minor	0	0 / Continuous	0
	dsgnlt	TextMisc	Text - Miscellaneous	0	0 / Continuous	1
	dsgnlt	TextNotes	Text - Notes	4	0 / Continuous	1
	dsgnlt	TextProfLabel	Text - Profile, Horizontal and Vertical Axis Labels	0	0 / Continuous	2
	dsgnlt	TextProjLabel	Text - Begin and End Project Label with Leader Lines	1	0 / Continuous	2
	dsgnlt	TextPtLabel	Text - Point Labels	4	0 / Continuous	0
	dsgnlt	TextShtNo	Text - Sheet Number	0	0 / Continuous	2
	dsgnlt	TextSubUtilLabel_ep	Text - Subsurface Utilities (Existing)	0	0 / Continuous	1
	dsgnlt	TextSurveyLabel	Text - Survey Labels	0	0 / Continuous	0
	dsgnlt	TextTables	Text - Key Sheet Indexes and Table Data	4	0 / Continuous	2
	dsgnlt	TextTitle	Text - Title	0	0 / Continuous	3
	dsgnlt	TextTopoLabel_ep	Text - Topography (Existing)	0	0 / Continuous	1
	dsgnlt	TextUtilLabel_ep	Text - Utilities (Existing)	0	0 / Continuous	1
	dsgnlt	TextXSElev	Text - Cross Section Elevations	2	0 / Continuous	1
	dsgnlt	Viewport	Viewport (For AutoCAD Use)	3	0 / Continuous	0
	dsgnlt	Xreference01_dp	Reference Files (For AutoCAD Use)	0	0 / Continuous	1

Critical	Rule	Level Name	Level Description	ByLevel Color	ByLevelStyle / Linetype	ByLevel Weight
	dsgnlt	Xreference02_dp	Reference Files (For AutoCAD Use)	0	0 / Continuous	1
	dsgnlt	Xreference03_dp	Reference Files (For AutoCAD Use)	0	0 / Continuous	1
	dsgnlt	Xreference04_dp	Reference Files (For AutoCAD Use)	0	0 / Continuous	1
	dsgnlt	XSCell	GEOPAK Cross Section Cell/Block and Profile Cell/Block	8	0 / Continuous	1

## DSGNRD - Roadway Design

Critical	Rule	Level Name	Level Description	ByLevel Color	ByLevelStyle / Linetype	ByLevel Weight
	dsgnrd	ActivePointCell_dp	Active Point Cell	4	0 / Continuous	10
	dsgnrd	AdhocPoint_dp	Adhoc Points Placed by SheetInfo	0	4 / DGN4	0
	dsgnrd	ArchSite_ep	Archeological Site (Existing)	2	0 / Continuous	1
X	dsgnrd	ArtificialCovering	Artificial Coverings	10	0 / Continuous	2
	dsgnrd	Assembly_dp	Civil 3D Assemblies and Subassemblies	4	0 / Continuous	2
	dsgnrd	ATDims	AutoTurn Profile Dimensions, Tire Envelope	1	0 / Continuous	1
X	dsgnrd	Attenuator	Attenuator Systems	6	MOT-Attenuator	1
X	dsgnrd	AttenuatorTM	Attenuator Truck Mount	6	0 / Continuous	2
	dsgnrd	ATTText	AutoTurn Profile and TT Dimensions, Annotation, TT Overhang	0	0 / Continuous	1
	dsgnrd	ATVHP	AutoTurn Temporary Profile for Building Custom Type	1	0 / Continuous	1
	dsgnrd	BaselineSurvey	Baseline Survey	0	0 / Continuous	2
X	dsgnrd	Berm	Berm (Top, Front, or Back)	10	0 / Continuous	2
X	dsgnrd	Berm_pm	Berm - Component Point Property and Model Break Line (Above Ground)	10	0 / Continuous	1
X	dsgnrd	BikeLaneColorPavt	Green Bike Lane Pavement	2	0 / Continuous	2
X	dsgnrd	Bollard	Concrete Filled Pipe Bollards	11	0 / Continuous	2
X	dsgnrd	Bottom_pm	Bottom - Component Point Property and Model Break Line (All)	0	0 / Continuous	1
X	dsgnrd	Bridge	Bridge	0	0 / Continuous	2
X	dsgnrd	Bridge_pm	Bridge - Component Point Property and Model Break Line (Above Ground)	2	0 / Continuous	1
X	dsgnrd	Bridge_px	Bridge Component on Cross Sections - Component Property	0	0 / Continuous	2
X	dsgnrd	BridgeAppSlab	Bridge Approaches and Slabs	0	0 / Continuous	2
X	dsgnrd	BridgeBot_pm	Bridge Bottom - Component Point Property and Model Break Line (Buried)	2	0 / Continuous	1
X	dsgnrd	BridgePiers	Bridge Piers	0	0 / Continuous	2
X	dsgnrd	Building	Buildings	1	0 / Continuous	2
X	dsgnrd	CableBarrier	Cable Barrier	0	RD-CableBarrier	2
X	dsgnrd	CableBarrier_px	Cable Barrier on Cross Sections	0	0 / Continuous	2
X	dsgnrd	Canal	Canal	7	0 / Continuous	1
X	dsgnrd	CandG_ex	Curb and Gutter on Cross Sections (All Types) (Existing)	4	2 / DGN2	1
X	dsgnrd	CandG_px	Curb and Gutter on Cross Sections (All Types)	4	0 / Continuous	2
X	dsgnrd	CandGBase_px	Curb and Gutter Base on Cross Sections	3	0 / Continuous	1
X	dsgnrd	CATVBur_ex	Cable TV and Miscellaneous on Cross Sections (Buried) (Existing)	6	2 / DGN2	1
X	dsgnrd	CATVBur_px	Cable TV and Miscellaneous on Cross Sections (Buried)	6	0 / Continuous	1
	dsgnrd	CLConst_dp	Center Line of Construction	0	0 / Continuous	2
X	dsgnrd	ClearingGrubbing	Clearing and Grubbing Limits and Quantity Items	4	0 / Continuous	1
	dsgnrd	ClearZone_dp	Clear Zone Elements	3	1 / DGN1	1
	dsgnrd	ClipBorder_dp	CLIP Border and Civil 3D View Frame	3	0 / Continuous	0
	dsgnrd	ClipDrawingBound_dp	CLIP Drawing Boundary	3	3 / DGN3	0

Critical	Rule	Level Name	Level Description	ByLevel Color	ByLevelStyle / Linetype	ByLevel Weight
	dsgnrd	Cloud_dp	Construction Cloud	7	0 / Continuous	2
	dsgnrd	COGO_dp	COGO Information	3	0 / Continuous	1
X	dsgnrd	Concrete	Concrete Areas and Miscellaneous (All Types)	0	0 / Continuous	2
X	dsgnrd	Concrete_px	Concrete Boundary Lines on Cross Sections	0	0 / Continuous	2
X	dsgnrd	ConcSlabs	Concrete Slabs	0	0 / Continuous	2
X	dsgnrd	Conduit_ex	Conduit and Encasements on Cross Sections (Existing)	3	2 / DGN2	1
X	dsgnrd	Conduit_px	Conduit and Encasements on Cross Sections	3	0 / Continuous	1
	dsgnrd	ConstArea_dp	Construction Area Crosshatch	0	0 / Continuous	1
	dsgnrd	ConstLimits	Construction Limits	3	RW-LimitsofConst	2
	dsgnrd	ConstLines	Construction Lines and References	1	0 / Continuous	0
	dsgnrd	ConstLines_pm	Construction Lines	4	0 / Continuous	0
	dsgnrd	ContoursMajor	Contour Lines Major	3	0 / Continuous	2
	dsgnrd	ContoursMajor_ep	Contour Lines Major (Existing)	3	1 / DGN1	1
	dsgnrd	ContoursMinor	Contour Lines Minor	4	0 / Continuous	2
	dsgnrd	ContoursMinor_ep	Contour Lines Minor (Existing)	4	1 / DGN1	1
	dsgnrd	ControlZone_dp	Control Zone	3	1 / DGN1	2
	dsgnrd	Core	Core Test Hole	9	1 / DGN1	1
X	dsgnrd	CorrHndlStg1_dp	Corridor Handle Display Setting for Corridor Design Stage 1	0	0 / Continuous	1
X	dsgnrd	CorrHndlStg2_dp	Corridor Handle Display Setting for Corridor Design Stage 2	4	0 / Continuous	1
X	dsgnrd	CorrHndlStg3_dp	Corridor Handle Display Setting for Corridor Design Stage 3	3	0 / Continuous	1
	dsgnrd	Corridor_dp	Civil 3D Corridors	0	0 / Continuous	2
X	dsgnrd	Curb_pm	Curb - Component Point Property and Model Break Line	4	0 / Continuous	1
X	dsgnrd	CurbBack	Back of Curb	4	0 / Continuous	1
X	dsgnrd	CurbBase_pm	Curb Base Top - Component Point Property and Model Break Line	3	0 / Continuous	1
X	dsgnrd	CurbFace	Curb and Gutter (Face)	4	0 / Continuous	1
X	dsgnrd	CurbFlowLine_pm	Curb Flow Line - Component Point Property and Model Break Line	4	0 / Continuous	1
X	dsgnrd	CurbRamp	Curb Cut Ramp	8	0 / Continuous	1
X	dsgnrd	CurbRampWarning	Detectable Warnings on Curb Ramps	4	0 / Continuous	2
	dsgnrd	CurveData_dp	Curve & Coordinate Data Elements Including PC, PT, PI Symbols	4	0 / Continuous	2
	dsgnrd	CurveDataLabel_dp	Curve Data Labels PC,PI, PT	0	0 / Continuous	2
X	dsgnrd	Cut_pm	Tie to Ground in Cut - Component Point Property and Model Break Line	3	0 / Continuous	1
	dsgnrd	DimLines_dp	Dimension Lines, Corresponding Terminators, Equation Lines	0	0 / Continuous	1
X	dsgnrd	Ditch	Ditch Top	7	6 / DGN6	1
X	dsgnrd	Ditch_px	Ditch Top on Cross Sections	7	0 / Continuous	2
X	dsgnrd	DitchBot	Ditch Bottom	10	0 / Continuous	2
X	dsgnrd	DitchBot_pm	Ditch Bottom - Component Point Property and Model Break Line	10	0 / Continuous	1
X	dsgnrd	DitchBot_px	Ditch Bottom on Cross Sections	10	0 / Continuous	2
X	dsgnrd	DitchPavt	Ditch Pavement Including Quantity Shapes	3	0 / Continuous	1
X	dsgnrd	DitchPavt_pm	Ditch Pavement Top - Component Point Property and Model Break Line	3	0 / Continuous	1
X	dsgnrd	DitchPavt_px	Ditch Pavement on Cross Sections	3	0 / Continuous	3
	dsgnrd	DitchProfLt_er	Ditch Profile Left (Existing)	8	3 / DGN3	1
	dsgnrd	DitchProfLt_pr	Ditch Profile Left	8	0 / Continuous	1
	dsgnrd	DitchProfMdn_er	Ditch Profile Median (Existing)	10	3 / DGN3	1
	dsgnrd	DitchProfMdn_pr	Ditch Profile Median	10	0 / Continuous	1
	dsgnrd	DitchProfRt_er	Ditch Profile Right (Existing)	9	3 / DGN3	1
	dsgnrd	DitchProfRt_pr	Ditch Profile Right	9	0 / Continuous	1

Critical	Rule	Level Name	Level Description	ByLevel Color	ByLevelStyle / Linetype	ByLevel Weight
X	dsgnrd	DitchTop_pm	Ditch Top - Component Point Property and Model Break Line	9	0 / Continuous	1
	dsgnrd	DrainAlert_px	Alert Symbolology for Structural Elements on Cross Sections	3	0 / Continuous	3
	dsgnrd	DrainMisc_ex	Drainage Elements on Cross Sections (All) (Miscellaneous) (Existing)	10	3 / DGN3	1
X	dsgnrd	DrainStruct	Drainage Structure in Plan	10	2 / DGN2	2
X	dsgnrd	DrainStruct_ex	Drainage Structures on Cross Sections (All) (Existing)	10	3 / DGN3	1
X	dsgnrd	DrainStruct_pr	Drainage Structures (All Types)	10	0 / Continuous	2
X	dsgnrd	DrainStruct_px	Drainage Structures and Elements on Cross Sections (Miscellaneous)	10	0 / Continuous	2
	dsgnrd	Driveway	Driveway (Drive, Lane, Turnouts)	7	0 / Continuous	2
X	dsgnrd	Driveway_ex	Driveway Lines on Cross Sections (Existing)	7	2 / DGN2	2
X	dsgnrd	Driveway_pm	Component Point Property and Model Break Line	7	0 / Continuous	1
X	dsgnrd	Driveway_px	Driveway Lines on Cross Sections	7	0 / Continuous	2
X	dsgnrd	DrivewayBase_px	Driveway Subgrade on Cross Sections	3	0 / Continuous	2
	dsgnrd	DTM	Digital Terrain Model, TIN Model Elements	1	0 / Continuous	2
	dsgnrd	DTM_ep	Digital Terrain Model, TIN Model Elements (Existing)	2	0 / Continuous	1
X	dsgnrd	DTM_ex	Digital Terrain Model on Cross Sections (Existing)	2	2 / DGN2	1
X	dsgnrd	DTM_px	Digital Terrain Model on Cross Sections	1	0 / Continuous	0
X	dsgnrd	DTMBotMesh	Bottom Surface TIN/DTM of the Proposed Corridor	60	0 / Continuous	1
X	dsgnrd	DTMTopMesh	Top Surface TIN/DTM of the Proposed Corridor	20	0 / Continuous	1
X	dsgnrd	DTMTriangles	DTM Triangles	1	0 / Continuous	2
X	dsgnrd	DTMTriangles_ep	DTM Triangles (Existing)	2	0 / Continuous	1
X	dsgnrd	DTMSource	Digital Terrain, Source Feature	0	0 / Continuous	2
X	dsgnrd	DTMSource_ep	Digital Terrain, Source Feature (Existing)	0	1 / DGN1	1
X	dsgnrd	DTMVertices	Digital Terrain Model, Triangle Vertices	0	0 / Continuous	2
X	dsgnrd	DTMVertices_ep	Digital Terrain Model, Triangle Vertices (Existing)	0	0 / Continuous	1
	dsgnrd	Earthwork1_px	Earthwork (Color 0) on Cross Sections	0	0 / Continuous	1
	dsgnrd	Earthwork2_px	Earthwork (Color 1) on Cross Sections	1	0 / Continuous	1
	dsgnrd	Earthwork3_px	Earthwork (Color 2) on Cross Sections	2	0 / Continuous	1
	dsgnrd	Earthwork4_px	Earthwork (Color 3) on Cross Sections	3	0 / Continuous	1
	dsgnrd	Earthwork5_px	Earthwork (Color 4) on Cross Sections	4	0 / Continuous	1
X	dsgnrd	EaseLicLine	Easement License Agreement Line	5	6 / DGN6	0
X	dsgnrd	EaseLine_ep	Easement Lines (Existing)	1	RW-Easement	1
X	dsgnrd	EasePerpLine	Easement Lines Perpetual	4	RW-PerpetualEasement	12
X	dsgnrd	EasePerpLine_px	Easement Lines Perpetual on Cross Sections	4	RW-PerpetualEasement	2
X	dsgnrd	EaseTempLine	Easement Lines Temporary	6	RW-TemporaryEasement	0
X	dsgnrd	EaseTempLine_ep	Easement Lines Temporary (Existing)	6	RW-TemporaryEasement	1
X	dsgnrd	EaseTempLine_px	Easement Lines Temporary on Cross Sections	6	RW-TemporaryEasement	0
X	dsgnrd	ElecBur_ex	Electrical on Cross Sections (Buried) (Existing)	3	2 / DGN2	1
X	dsgnrd	ElecBur_px	Electrical on Cross Sections (Buried)	3	0 / Continuous	1
X	dsgnrd	Endwall_px	Endwall on Cross Sections	10	0 / Continuous	2
	dsgnrd	EnvlImpact_ep	Locations for Potential Environmental Concerns (Existing)	3	0 / Continuous	1
	dsgnrd	ExcavationLimits_dp	Excavation Limits on Cross Sections	0	0 / Continuous	1
X	dsgnrd	Fence	Fence, Sand Fence	6	RD-Fence	1
	dsgnrd	Fence_ex	Fence Lines on Cross Sections (Existing)	6	3 / DGN3	1
X	dsgnrd	Fence_pm	Fence - Component Point Property and Model Break Line Above Ground	6	0 / Continuous	1
X	dsgnrd	Fence_px	Fence Lines on Cross Sections	6	RD-Fence	2
X	dsgnrd	FenceLt	Fence - Limited Access Left	6	RD-Fence	1

Critical	Rule	Level Name	Level Description	ByLevel Color	ByLevelStyle / Linetype	ByLevel Weight
X	dsgnrd	FenceRt	Fence - Limited Access Right	6	RD-Fence	1
X	dsgnrd	FES_px	Flared End Sections on Cross Sections	10	0 / Continuous	2
X	dsgnrd	Fill_pm	Tie to Ground in Fill - Component Point Property and Model Break Line	1	0 / Continuous	1
	dsgnrd	FlowArrow	Digital Terrain Model, Triangle Flow Arrows	10	0 / Continuous	2
	dsgnrd	FlowArrow_ep	Digital Terrain Model, Triangle Flow Arrows (Existing)	10	0 / Continuous	2
	dsgnrd	FlowLine_pr	Flow Line (Roadway Profile View)	0	0 / Continuous	2
X	dsgnrd	FlowPaths	Time of Concentration Flow Paths	10	1 / DGN1	1
X	dsgnrd	FOCBur_ex	Fiber Optics Cable on Cross Sections (Buried) (Existing)	6	2 / DGN2	1
X	dsgnrd	FOCBur_px	Fiber Optics Cable on Cross Sections (Buried)	6	0 / Continuous	1
X	dsgnrd	FOEElecBur_ex	Fiber Optics Electrical on Cross Sections (Buried) (Existing)	3	2 / DGN2	1
X	dsgnrd	FOEElecBur_px	Fiber Optics Electrical on Cross Sections (Buried)	3	0 / Continuous	1
X	dsgnrd	FOTBur_ex	Fiber Optics Telephone on Cross Sections (Buried) (Existing)	6	2 / DGN2	1
X	dsgnrd	FOTBur_px	Fiber Optics Telephone on Cross Sections (Buried)	6	0 / Continuous	1
X	dsgnrd	Gabions	Gabion Baskets or Mats	10	0 / Continuous	2
X	dsgnrd	Gabions_ep	Gabion Baskets or Mats (Existing)	10	1 / DGN1	2
X	dsgnrd	Gas_ex	Gas Pipe and Fittings on Cross Sections (Miscellaneous) (Existing)	4	2 / DGN2	
X	dsgnrd	Gas_px	Gas Pipe and Fittings on Cross Sections (Miscellaneous)	4	0 / Continuous	
	dsgnrd	GeotechFillPatt1	Geotechnical Fill Pattern - (Earth, Wood, Muck, Concrete, Rock, Riprap) as Defined in Project	3	0 / Continuous	
	dsgnrd	GeotechFillPatt1_px	Geotechnical Fill Pattern on Cross Sections - (Earth, Wood, Muck, Concrete, Rock, Riprap) as Defined in Project	3	0 / Continuous	
	dsgnrd	GeotechFillPatt2	Geotechnical Fill Pattern - Clay, Sand	0	1 / DGN1	
	dsgnrd	GeotechFillPatt2_px	Geotechnical Fill Pattern on Cross Sections - Clay, Sand	0	1 / DGN1	
	dsgnrd	GeotechFillPatt3	Geotechnical Fill Pattern - Shell	3	1 / DGN1	
	dsgnrd	GeotechFillPatt3_px	Geotechnical Fill Pattern on Cross Sections - Shell	3	1 / DGN1	
	dsgnrd	GeotechFillPatt4	Geotechnical Fill Pattern - Sand	4	0 / Continuous	
	dsgnrd	GeotechFillPatt4_px	Geotechnical Fill Pattern on Cross Sections - Sand	4	0 / Continuous	
	dsgnrd	GeotechFillPatt5	Geotechnical Fill Pattern - Coquina	1	0 / Continuous	
	dsgnrd	GeotechFillPatt5_px	Geotechnical Fill Pattern on Cross Sections - Coquina	1	0 / Continuous	
	dsgnrd	GeotechFillPatt6	Geotechnical Fill Pattern - Limestone	2	0 / Continuous	
	dsgnrd	GeotechFillPatt6_px	Geotechnical Fill Pattern on Cross Sections - Limestone	2	0 / Continuous	
	dsgnrd	GeotechFillPatt7	Geotechnical Fill Pattern - Gravel	6	0 / Continuous	
	dsgnrd	GeotechFillPatt7_px	Geotechnical Fill Pattern on Cross Sections - Gravel	6	0 / Continuous	
	dsgnrd	GeotechFillPatt8	Geotechnical Fill Pattern - Silt	0	0 / Continuous	
	dsgnrd	GeotechFillPatt8_px	Geotechnical Fill Pattern on Cross Sections - Silt	0	0 / Continuous	
	dsgnrd	GeotechMisc	Geotechnical Elements (Miscellaneous)	0	0 / Continuous	
X	dsgnrd	GovTwpRgeLine_ep	Township / Range Lines (Existing)	10	RW-TownshipRange	2
	dsgnrd	GPKDrBack_dp	Back Point on Drainage Cells	2	2 / DGN2	2
	dsgnrd	GPKDrBottom_dp	Bottom Point on Drainage Cells	3	3 / DGN3	2
	dsgnrd	GPKDrCellIns_dp	Cell Insertion Point on Drainage Cells	4	4 / DGN4	2
	dsgnrd	GPKDrCentroid_dp	Point on Centroid for Drainage	7	7 / DGN7	2
	dsgnrd	GPKDrElv	Location Point for Drainage Cells	5	5 / DGN5	2
	dsgnrd	GPKDrFront_dp	Front Point on Drainage Cells	1	1 / DGN1	2
	dsgnrd	GPKDrPipe_dp	Point on Drainage Pipe	6	6 / DGN6	2
	dsgnrd	GPKDrPipeCir_dp	Point on Pipe Circular	6	6 / DGN6	0
	dsgnrd	GradeLine_er	Grade Line Profile (Existing)	2	2 / DGN2	1
	dsgnrd	GradeLine_pr	Grade Line Profile	5	0 / Continuous	2
	dsgnrd	GradeLineCtr_dp	Grade Line Profile Center (Shown in Plan View)	5	0 / Continuous	0

Critical	Rule	Level Name	Level Description	ByLevel Color	ByLevelStyle / Linetype	ByLevel Weight
	dsgnrd	GradeLineCtr_pr	Grade Line Profile Center	5	0 / Continuous	0
	dsgnrd	GradeLineLt_dp	Grade Line Profile Left (Shown in Plan View)	1	0 / Continuous	0
	dsgnrd	GradeLineLt_er	Grade Line Profile Left (Existing)	1	2 / DGN2	0
	dsgnrd	GradeLineLt_pr	Grade Line Profile Left	1	0 / Continuous	0
	dsgnrd	GradeLineRt_dp	Grade Line Profile Right (Shown in Plan View)	4	0 / Continuous	0
	dsgnrd	GradeLineRt_er	Grade Line Profile Right (Existing)	4	2 / DGN2	0
	dsgnrd	GradeLineRt_pr	Grade Line Profile Right	4	0 / Continuous	0
	dsgnrd	GradeSecPat	Grade Section Patterns	0	0 / Continuous	0
X	dsgnrd	Grass	Grass, Seeding and Mulching Areas	2	1 / DGN1	2
	dsgnrd	GridMaj_dp	Grid Lines Major in Profile and Cross Section	3	0 / Continuous	1
	dsgnrd	GridMin_dp	Grid Lines Minor in Profile and Cross Section	0	0 / Continuous	0
	dsgnrd	GridMinG_dp	Grid Lines Minor Sub 2 on Cross Section Sheets	20	0 / Continuous	0
	dsgnrd	GridMinSub_dp	Grid Lines Minor Sub on Cross Section Sheets	20	0 / Continuous	0
X	dsgnrd	Guardrail	Guardrail	1	0 / Continuous	1
X	dsgnrd	Guardrail_ex	Guardrail Lines on Cross Sections (Existing)	0	2 / DGN2	2
X	dsgnrd	Guardrail3dDbI_pm	Guardrail - Component Point Property and Model Break Line for 3D Guardrail Posts (Double)	9	3D-Guardrail-Double / Continuous	0
X	dsgnrd	Guardrail3dLt_pm	Guardrail - Component Point Property and Model Break Line for 3D Guardrail Posts (Left)	9	3D-Guardrail-Left / Continuous	0
X	dsgnrd	Guardrail3dRt_pm	Guardrail - Component Point Property and Model Break Line for 3D Guardrail Posts (Right)	9	3D-Guardrail-Right / Continuous	0
X	dsgnrd	GuardrailBRLt	Guardrail Bridge (Left)	0	RD-Guardrail-Left	1
X	dsgnrd	GuardrailBRRt	Guardrail Bridge (Right)	0	RD-Guardrail-Right	1
X	dsgnrd	GuardrailDbI	Guardrail (Double Face)	0	RD-Guardrail-Double	1
X	dsgnrd	GuardrailEndAch	Guardrail (End Anchorage)	0	0 / Continuous	1
X	dsgnrd	GuardrailLt	Guardrail (Left)	0	RD-Guardrail-Left	1
X	dsgnrd	GuardrailModThrieDbI	Guardrail Modified Thrie Beam (Double Face)	0	RD-Guardrail-Double	1
X	dsgnrd	GuardrailModThrieLt	Guardrail Modified Thrie Beam (Left)	0	RD-Guardrail-Left	1
X	dsgnrd	GuardrailModThrieRt	Guardrail Modified Thrie Beam (Right)	0	RD-Guardrail-Right	1
X	dsgnrd	GuardrailPanel_pm	Guardrail - Component Point Property and Model Break Line for Guardrail Panels	11	0 / Continuous	1
X	dsgnrd	GuardrailPanel_px	Guardrail Component Property on Cross Sections for 3D Guardrail Panels	11	0 / Continuous	1
X	dsgnrd	GuardrailPost_pm	Guardrail - Component Point Property and Model Break Line for Guardrail Posts	10	0 / Continuous	1
X	dsgnrd	GuardrailPost_px	Guardrail Component Property on Cross Sections for 3D Guardrail Posts	10	0 / Continuous	0
X	dsgnrd	GuardrailPRDbI	Guardrail Double Face w/ Pipe Rail	0	RD-Guardrail-Double	1
X	dsgnrd	GuardrailPRLt	Guardrail Left w/ Pipe Rail	0	RD-Guardrail-Left	1
X	dsgnrd	GuardrailPRRt	Guardrail Right w/ Pipe Rail	0	RD-Guardrail-Right	1
X	dsgnrd	GuardrailRRDbI	Guardrail Double Face w/ Rub Rail	0	RD-Guardrail-Double	1
X	dsgnrd	GuardrailRRLt	Guardrail Left w/ Rub Rail	0	RD-Guardrail-Left	1
X	dsgnrd	GuardrailRRRt	Guardrail Right w/ Rub Rail	0	RD-Guardrail-Right	1
X	dsgnrd	GuardrailRt	Guardrail Right	0	RD-Guardrail-Right	1
X	dsgnrd	GuardrailThrieDbI	Guardrail Thrie Beam Double Face	0	RD-Guardrail-Double	1
X	dsgnrd	GuardrailThrieLt	Guardrail Thrie Beam Left	0	RD-Guardrail-Left	1
X	dsgnrd	GuardrailThriePRLt	Guardrail Thrie Beam Left w/ Pipe Rail	0	RD-Guardrail-Left	1
X	dsgnrd	GuardrailThriePRRt	Guardrail Thrie Beam Right w/ Pipe Rail	0	RD-Guardrail-Right	1
X	dsgnrd	GuardrailThrieRt	Guardrail Thrie Beam Right	0	RD-Guardrail-Right	1
	dsgnrd	HardscapeDetails	Paving Details, Fence Railing, Stamped Asphalt	4	0 / Continuous	2
	dsgnrd	ImageAttachment_dp	Image Attachments	0	0 / Continuous	0
X	dsgnrd	Inlet_px	Inlets on Cross Sections	10	0 / Continuous	2
X	dsgnrd	InletBottom_px	Inlet Bottom on Cross Sections (All Types)	10	0 / Continuous	2



Critical	Rule	Level Name	Level Description	ByLevel Color	ByLevelStyle / Linetype	Bylevel Weight
X	dsgnrd	InletProt	Rock Bags and Sand Bagging	10	SWP-RockBags	2
	dsgnrd	KeyShtMisc	Key Sheet Items (Miscellaneous)	0	0 / Continuous	2
	dsgnrd	LaneLine	Lane Lines (Defines Changes in Pavement Cross Slope) (Non-Plotting)	4	3 / DGN3	2
X	dsgnrd	LARWLine	Limited Access Right of Way Lines	4	RW-LimitedAccess-Proposed	2
X	dsgnrd	LARWLine_ep	Limited Access Right of Way Lines (Existing)	4	RW-LimitedAccess-Existing	1
X	dsgnrd	LARWLine_ex	Limited Access Right of Way Lines on Cross Sections (Existing)	4	RW-LimitedAccess-Existing	1
X	dsgnrd	LARWLine_px	Limited Access Right of Way Lines on Cross Sections	4	RW-LimitedAccess-Proposed	2
X	dsgnrd	LateralLimits_px	Lateral Limits on Cross Sections	6	0 / Continuous	2
	dsgnrd	LeaderLine_dp	Leader Line and Terminator with Text	0	0 / Continuous	1
	dsgnrd	Logo_dp	Consultant Engineer of Record Logo	0	0 / Continuous	1
X	dsgnrd	Mailbox	Mailboxes	8	0 / Continuous	1
	dsgnrd	Manhole_ex	Manhole on Cross Sections (Existing)	10	3 / DGN3	2
X	dsgnrd	Manhole_px	Manhole on Cross Sections	10	0 / Continuous	2
	dsgnrd	MatchLineMask_dp	Mask Area for Match Line Overlap Areas (For AutoCAD Use)	0	0 / Continuous	0
	dsgnrd	MatchLines_dp	Match Lines with Text, Arrows for Station Notations	1	0 / Continuous	2
X	dsgnrd	MedianCrown_pm	Median Crown - Component Point Property and Model Break Line	9	0 / Continuous	1
X	dsgnrd	MES_px	Mitered End Section on Cross Sections	10	0 / Continuous	2
	dsgnrd	Miscellaneous0	Undefined Proposed Item - Color Blue Weight 0	1	0 / Continuous	0
	dsgnrd	Miscellaneous1	Undefined Proposed Item - Color Blue Weight 1	1	0 / Continuous	1
	dsgnrd	Miscellaneous2	Undefined Proposed Item - Color Blue Weight 2	1	0 / Continuous	2
	dsgnrd	Miscellaneous3	Undefined Proposed Item - Color Green Weight 0	2	0 / Continuous	0
	dsgnrd	Miscellaneous4	Undefined Proposed Item - Color Green Weight 1	2	0 / Continuous	1
	dsgnrd	Miscellaneous5	Undefined Proposed Item - Color Green Weight 2	2	0 / Continuous	2
	dsgnrd	Miscellaneous6	Undefined Proposed Item - Color Red Weight 0	3	0 / Continuous	0
	dsgnrd	Miscellaneous7	Undefined Proposed Item - Color Red Weight 1	3	0 / Continuous	1
	dsgnrd	Miscellaneous8	Undefined Proposed Item - Color Red Weight 2	3	0 / Continuous	2
	dsgnrd	Miscellaneous9	Undefined Proposed Item - Color Red Weight 3	3	0 / Continuous	3
	dsgnrd	NonPlottingEle_dp	Non-Plotting Items - Construction Elements, Type 66 Elements, Etc.	4	0 / Continuous	0
	dsgnrd	NorthArw_dp	North Arrows	0	0 / Continuous	2
	dsgnrd	Patternlines_ep	Cross Section Chain (Existing)	2	1 / DGN1	0
	dsgnrd	PatternLines1_dp	Pattern Lines on Cross Sections and All Autodesk (Civil 3D) Tables	3	0 / Continuous	2
	dsgnrd	PatternLines2_dp	Pattern Lines on Cross Sections Alternate for Side Streets, CriticalCross Sections or Drainage Structures	4	0 / Continuous	2
	dsgnrd	PatternLines3_dp	Pattern Lines on Cross Sections Alternate for Side Streets, CriticalCross Sections or Drainage Structures	5	0 / Continuous	2
X	dsgnrd	PavedMedianBase_px	Median Subgrade on Cross Sections (Paved)	3	0 / Continuous	2
	dsgnrd	Pavers	Pavers - Brick and Block	5	0 / Continuous	1
X	dsgnrd	PavtAsphalt	Asphalt Pavement Edge Line and Quantity Shapes	0	0 / Continuous	2
	dsgnrd	PavtAsphalt_ep	Asphalt Pavement Edge (Existing)	0	3 / DGN3	1
X	dsgnrd	PavtAsphalt_pm	Asphalt Pavement Edge Line - Component Point Property and Model Break Line	0	0 / Continuous	1
X	dsgnrd	PavtAsphalt_px	Asphalt Pavement on Cross Sections and Components in Models	1	0 / Continuous	2
X	dsgnrd	PavtBase	Base Material (All Types)	3	0 / Continuous	2
X	dsgnrd	PavtBase_ex	Base Material on Cross Sections (All Types) (Existing)	3	3 / DGN3	1
X	dsgnrd	PavtBase_pm	Pavement Base Top - Component Point Property and Model Break Line	3	0 / Continuous	1
X	dsgnrd	PavtBase_px	Base Material on Cross Sections (All Types)	3	0 / Continuous	2
	dsgnrd	PavtBreak_dp	Line Defining a Pavement Slope Break	0	0 / Continuous	1
X	dsgnrd	PavtBreak_pm	Break in Slope or Lane on Pavement - Component Point Property and Model Break Line	0	0 / Continuous	1

Critical	Rule	Level Name	Level Description	ByLevel Color	ByLevelStyle / Linetype	ByLevel Weight
X	dsgnrd	PavtConcrete	Concrete Pavement Edge Lines and Quantity Shapes	10	0 / Continuous	2
X	dsgnrd	PavtConcrete_pm	Concrete Pavement - Component Point Property and Model Break Line	0	0 / Continuous	1
X	dsgnrd	PavtConcrete_px	Concrete Pavement on Cross Sections and Components in Models	0	0 / Continuous	2
X	dsgnrd	PavtConcreteSC	Concrete Surface Coloring	9	0 / Continuous	1
	dsgnrd	PavtCrown	Pavement Crown	16	0 / Continuous	2
X	dsgnrd	PavtCrown_pm	Pavement Crown - Component Point Property and Model Break Line	16	0 / Continuous	1
X	dsgnrd	PavtFrictionCourse	Asphalt Concrete Friction Course	4	0 / Continuous	2
	dsgnrd	PavtMilling	Milling and Resurfacing Limits and Quantity Shapes	1	0 / Continuous	2
X	dsgnrd	PavtMilling_pm	Asphalt Milling - Component Point Property and Model Break Line	7	0 / Continuous	1
X	dsgnrd	PavtMilling_px	Asphalt Milling Lines on Cross Sections	7	0 / Continuous	2
	dsgnrd	PavtMisc	Asphalt Material (Miscellaneous)	1	0 / Continuous	1
X	dsgnrd	PavtMisc_pm	Pavement - Component Point Property and Model Break Line (Miscellaneous)	1	0 / Continuous	1
X	dsgnrd	PavtMisc_px	Pavement on Cross Sections (Miscellaneous)	1	0 / Continuous	2
X	dsgnrd	PavtOverbuild_pm	Pavement Overbuild - Component Point Property and Model Break Line	1	0 / Continuous	1
X	dsgnrd	PavtOverbuild_px	Pavement Overbuild Areas on Cross Sections - Component Property	4	0 / Continuous	2
X	dsgnrd	PavtOverlay_pm	Pavement Overlay - Component Point Property and Model Break Line	1	0 / Continuous	1
X	dsgnrd	PavtOverlay_px	Pavement Overlay on Cross Sections - Component Property	1	0 / Continuous	2
X	dsgnrd	PavtOverlay1_px	Pavement Overlay on Cross Sections - Component Property	14	0 / Continuous	2
X	dsgnrd	PavtOverlay2_px	Pavement Overlay on Cross Sections - Component Property	7	0 / Continuous	2
X	dsgnrd	PavtStabilization	Stabilization Material Lines and Shapes	9	0 / Continuous	2
X	dsgnrd	PavtStabilization_px	Stabilization on Cross Sections	5	2 / DGN2	2
	dsgnrd	PavtXover_ep	Crossovers and Detours (Temporary) (Existing)	0	3 / DGN3	0
	dsgnrd	PayItem_dp	Pay Item Number Label Elements	4	0 / Continuous	2
	dsgnrd	Permit1	Permit 1 Wetlands, Mitigation Sites, Planting Areas	1	0 / Continuous	1
	dsgnrd	Permit2	Permit 2 Wetlands, Mitigation Sites, Planting Areas	2	0 / Continuous	1
	dsgnrd	Permit3	Permit 3 Wetlands, Mitigation Sites, Planting Areas	4	0 / Continuous	1
X	dsgnrd	Piling	Piling Piers or Column	8	0 / Continuous	2
X	dsgnrd	PipeCulvert	Pipe Culvert in Plan	10	2 / DGN2	2
	dsgnrd	PipeCulvert_ep	Pipe Culvert (Existing)	10	3 / DGN3	1
X	dsgnrd	PipeCulvert_ex	Pipe Culvert in Cross Sections (Existing)	10	3 / DGN3	1
X	dsgnrd	PipeCulvert_pr	Pipe Culvert in Profile	10	0 / Continuous	2
X	dsgnrd	PipeCulvert_px	Pipe Culvert on Cross Section View	10	0 / Continuous	2
X	dsgnrd	PlotBorder_dp	Plot Border	3	0 / Continuous	0
	dsgnrd	PointLocator_ep	Point Locator Symbol (Existing)	4	0 / Continuous	0
X	dsgnrd	Pond_px	Pond Lines on Cross Sections	2	0 / Continuous	2
X	dsgnrd	PondSideSlope	Pond Side Slope	0	0 / Continuous	2
X	dsgnrd	PropertyLine_ep	Property Lines (Existing)	3	0 / Continuous	0
X	dsgnrd	PvtAnalysisCrown_pm	Pavement Analysis Crowning - Point Property	7	0 / Continuous	1
X	dsgnrd	PvtAnalysisCrown_px	Pavement Analysis Crowning on Cross Sections - Component Property	7	0 / Continuous	1
X	dsgnrd	PvtAnalysisFail_pm	Pavement Analysis Failure - Point Property	3	0 / Continuous	1
X	dsgnrd	PvtAnalysisFail_px	Pavement Analysis Failure on Cross Sections - Component Property	3	0 / Continuous	1
X	dsgnrd	PvtAnalysisMax_pm	Pavement Analysis Acceptable Maximum Range - Point Property	5	0 / Continuous	1
X	dsgnrd	PvtAnalysisMax_px	Pavement Analysis Acceptable Maximum Range on Cross Sections - Component Property	5	0 / Continuous	1
X	dsgnrd	PvtAnalysisMin_pm	Pavement Analysis Acceptable Minimum Range - Point Property	4	0 / Continuous	1
X	dsgnrd	PvtAnalysisMin_px	Pavement Analysis Acceptable Minimum Range on Cross Sections - Component Property	4	0 / Continuous	1
X	dsgnrd	PvtAnalysisOptiml_pm	Pavement Analysis Optimal - Point Property	2	0 / Continuous	1



Critical	Rule	Level Name	Level Description	ByLevel Color	ByLevelStyle / Linetype	ByLevel Weight
X	dsgnrd	PvtAnalysisOptiml_px	Pavement Analysis Optimal on Cross Sections - Component Property	2	0 / Continuous	1
X	dsgnrd	Railing	Railings; Piperail, Guiderail, Handrail used for Pedestrian and Bicycles (All)	9	0 / Continuous	2
X	dsgnrd	Railing_pm	Railing Top - Component Point Property and Model Break Line	9	0 / Continuous	1
X	dsgnrd	Railing_px	Railing Components and Cross Sections Shapes	9	0 / Continuous	2
	dsgnrd	RailroadDetails	Railroad Crossing Details	3	0 / Continuous	2
	dsgnrd	RailroadXing	Railroad Crossing Elements	11	0 / Continuous	0
	dsgnrd	ReferencePt_dp	Survey and Construction Reference Point Details and Elements	4	0 / Continuous	2
	dsgnrd	RegionBdry_dp	Boundary Line for Regions in Corridor Design (For AutoCAD Use)	0	0 / Continuous	0
X	dsgnrd	RetentionArea	Retention Area	2	0 / Continuous	2
X	dsgnrd	RipRap	Rip Rap, Rubble	4	0 / Continuous	2
X	dsgnrd	RipRap_px	Rip Rap, Rubble on Cross Sections	4	1 / DGN1	
	dsgnrd	RoadwayMisc	Roadway Items (Miscellaneous)	4	0 / Continuous	2
X	dsgnrd	RumbleStrip1	Rumble Strips Continuous Array	0	PM-RumbleSolid	2
X	dsgnrd	RumbleStrip2	Rumble Strips Skip Array	0	PM-RumbleSkip	2
X	dsgnrd	RWLine	Right of Way Lines	4	RW-Proposed	2
X	dsgnrd	RWLine_ep	Right of Way Lines (Existing)	3	RW-Existing	1
X	dsgnrd	RWLine_ex	ROW Lines on Cross Sections (Existing)	3	RW-Existing	1
X	dsgnrd	RWLine_px	ROW Lines on Cross Sections	4	RW-Proposed	2
X	dsgnrd	SanitaryFM_ex	Force Main Lines on Cross Sections (Existing)	2	2 / DGN2	1
X	dsgnrd	SanitaryFM_px	Force Main Lines on Cross Sections	2	0 / Continuous	1
X	dsgnrd	SanitarySewer_ex	Sanitary Sewer on Cross Sections (Existing)	2	2 / DGN2	0
X	dsgnrd	SanitarySewer_px	Sanitary Sewer on Cross Sections	2	0 / Continuous	2
X	dsgnrd	SanitarySewerEff_ex	Sanitary Sewer Effluent on Cross Sections (Existing)	5	0 / Continuous	0
X	dsgnrd	SanitarySewerEff_px	Sanitary Sewer Effluent on Cross Sections	5	0 / Continuous	0
X	dsgnrd	SawCuts	Saw Cuts	3	3 / DGN3	0
	dsgnrd	Scale_dp	Bar Scale, Scale Label Elements	0	0 / Continuous	2
	dsgnrd	Scratch1_dp	Scratch Level for Temporary or Informational Items	4	0 / Continuous	0
	dsgnrd	Scratch2_dp	Scratch Level for Temporary or Informational Items	5	0 / Continuous	0
	dsgnrd	ScratchEle_dp	Scratch Level for Draft Elements, Temporary Elements, Etc. (DO NOT PLOT)	3	0 / Continuous	0
	dsgnrd	ScratchEle2_dp	Scratch Level for Draft Elements, Temporary Elements, Etc. (DO NOT PLOT)	4	0 / Continuous	0
101	dsgnrd	SedimentBarrier	Synthetic Bales and Staked Silt Fences	10	SWP-HayBales	2
101	dsgnrd	SedimentBarrier	Synthetic Bales and Staked Silt Fences	10	SWP-SiltFence	2
X	dsgnrd	SedimentBasin	Sediment Basin Index 101	10	0 / Continuous	2
X	dsgnrd	SedimentBasin_ep	Sediment Basin Index 101 (Existing)	10	3 / DGN3	1
	dsgnrd	SheetBorder_dp	Sheet Border	1	0 / Continuous	4
	dsgnrd	SheetLines_dp	Sheet Lines	1	0 / Continuous	2
	dsgnrd	SheetLinesMisc1_dp	Sheet Lines	1	0 / Continuous	0
	dsgnrd	SheetLinesMisc2_dp	Sheet Lines	2	0 / Continuous	2
	dsgnrd	SheetLinesMisc3_dp	Sheet Lines	3	0 / Continuous	2
	dsgnrd	SheetLinesMisc4_dp	Sheet Lines	4	0 / Continuous	2
X	dsgnrd	ShldrBase_pm	Shoulder Base - Component Point Property and Model Break Line	3	0 / Continuous	1
X	dsgnrd	ShldrBase_px	Shoulder Base on Cross Sections	3	0 / Continuous	2
	dsgnrd	ShldrHatch	Shoulder Hatch Pattern	1	0 / RD-PavedShldr6	1
X	dsgnrd	ShldrMilling_pm	Shoulder Milling - Component Point Property and Model Break Line	7	0 / Continuous	1
X	dsgnrd	ShldrMilling_px	Shoulder Milling on Cross Sections - Component Property	7	0 / Continuous	2
X	dsgnrd	ShldrOverbuild_px	Shoulder Overbuild on Cross Sections - Component Property	4	0 / Continuous	1

Critical	Rule	Level Name	Level Description	ByLevel Color	ByLevelStyle / Linetype	ByLevel Weight
X	dsgnrd	ShldrOverlay_px	Shoulder Overlay on Cross Sections - Component Property	1	0 / Continuous	1
X	dsgnrd	ShldrPavBreak_pm	Shoulder Pavement Roll Over Break - Component Point Property and Model Break Line	1	0 / Continuous	1
X	dsgnrd	ShldrPaved	Shoulder Line (Paved)	1	0 / Continuous	1
X	dsgnrd	ShldrPaved_pm	Shoulder Pavement - Component Point Property and Model Break Line	1	0 / Continuous	1
X	dsgnrd	ShldrPaved_px	Shoulder Lines on Cross Sections (Paved)	1	0 / Continuous	2
X	dsgnrd	ShldrUnpavBreak_pm	Shoulder Roll Over Break - Component Point Property and Model Break Line (Unpaved)	2	0 / Continuous	1
X	dsgnrd	ShldrUnpaved	Shoulder Line (Unpaved)	0	0 / Continuous	0
X	dsgnrd	ShldrUnpaved_px	Shoulder Line on Cross Sections (Unpaved)	2	0 / Continuous	2
X	dsgnrd	Sidewalk_ex	Sidewalk Elements on Cross Sections (Existing)	0	2 / DGN2	1
X	dsgnrd	Sidewalk_pm	Sidewalk - Component Point Property and Model Break Line	0	0 / Continuous	1
X	dsgnrd	Sidewalk_px	Sidewalk Elements on Cross Sections	0	0 / Continuous	2
X	dsgnrd	SidewalkBack	Back of Sidewalk	2	0 / Continuous	1
	dsgnrd	SidewalkBack_er	Back of Sidewalk Line Profile (Existing)	2	2 / DGN2	1
	dsgnrd	SidewalkBack_pr	Back of Sidewalk Line Profile	5	0 / Continuous	2
X	dsgnrd	SidewalkBase_px	Sidewalk Subgrade on Cross Sections	3	0 / Continuous	2
X	dsgnrd	SidewalkConc	Sidewalk Concrete Shape	0	0 / Continuous	2
X	dsgnrd	SidewalkFront	Front of Sidewalk	1	0 / Continuous	1
X	dsgnrd	Slopes	Slopes (Top, Bottom)	9	3 / DGN3	0
X	dsgnrd	Slopes_px	Slope Lines on Cross Sections	9	0 / Continuous	2
X	dsgnrd	SlopesBreak_pm	Slopes - Component Point Property and Model Break Line	9	0 / Continuous	1
X	dsgnrd	SlopeStakes1	Slope Stakes 1	4	1 / DGN1	3
X	dsgnrd	SlopeStakes2	Slope Stakes 2	1	1 / DGN1	3
X	dsgnrd	SnglStaHndl_dp	Single Station Handle Display Setting for All Design Stages	44	0 / Continuous	1
X	dsgnrd	Sod	Performance Sod	2	0 / Continuous	2
X	dsgnrd	SoilBoring	Soil Boring Elements	5	0 / Continuous	1
	dsgnrd	SoilBoringLoc_dp	Soil Boring Location Symbol	4	0 / Continuous	2
	dsgnrd	SoilBoxes_dp	Soil Boxes	4	0 / Continuous	1
X	dsgnrd	SoilBoxes_px	Soil Boxes and Borings on Cross Sections	4	0 / Continuous	1
	dsgnrd	SpecialDetails	Special Details	6	0 / Continuous	1
X	dsgnrd	SpecialDetails_px	Special Details on Cross Sections	6	0 / Continuous	1
	dsgnrd	StationTicL_dp	Station Tic Marks (Large) and Text	0	0 / Continuous	2
	dsgnrd	StationTicS_dp	Station Tic Marks (Small) and Text	0	0 / Continuous	2
	dsgnrd	StreetLights_px	Street Lights on Cross Sections	3	0 / Continuous	1
X	dsgnrd	StructuralCourse	Asphaltic Concrete Structural Course	6	0 / Continuous	2
	dsgnrd	Structure	Structures	0	0 / Continuous	2
	dsgnrd	Structure_px	Signal and Sign Structures on Cross Sections	0	0 / Continuous	2
X	dsgnrd	SubDsgn_px	Sub Design on Cross Sections Including Subbase	4	0 / Continuous	1
X	dsgnrd	Subsoil_px	Subsoil Or Undercut on Cross Sections	4	0 / Continuous	2
X	dsgnrd	SubsoilFinal_px	Subsoil Final for Multiline on Cross Sections	18	0 / Continuous	1
X	dsgnrd	SubsoilProp_px	Subsoil Proposed for Multiline on Cross Sections	8	0 / Continuous	1
	dsgnrd	SumBoxBorder_dp	Summary Boxes Borders	4	0 / Continuous	3
	dsgnrd	SumBoxLines_dp	Summary Boxes Lines and Miscellaneous Items	4	0 / Continuous	1
	dsgnrd	SumBoxLinesMin_dp	Summary Boxes Lines Minor Line and Miscellaneous Items	4	0 / Continuous	0
X	dsgnrd	Tables_dp	Data Tables and All Autodesk Tables	0	0 / Continuous	1
X	dsgnrd	TeleBur_ex	Telephone on Cross Sections (Buried) (Miscellaneous) (Existing)	6	2 / DGN2	1
X	dsgnrd	TeleBur_px	Telephone on Cross Sections (Buried) (Miscellaneous)	6	0 / Continuous	1

Critical	Rule	Level Name	Level Description	ByLevel Color	ByLevelStyle / Linetype	ByLevel Weight
X	dsgnrd	TemplateBottom_px	Bottom of Template for Multiline on Cross Sections	6	0 / Continuous	1
X	dsgnrd	TemplateFinal_px	Final Template for Multiline on Cross Sections	2	0 / Continuous	1
X	dsgnrd	TemplateTop_px	Top of Template for Multiline on Cross Sections	7	0 / Continuous	1
X	dsgnrd	TerrainLine_ex	Ground Line for Multiline on Cross Sections (Existing)	5	0 / Continuous	1
	dsgnrd	TextAlert	Text - Alert Label to Highlight a Problem	3	0 / Continuous	2
	dsgnrd	TextBLStation	Text - B/L Station and Tics	0	0 / Continuous	2
	dsgnrd	TextConstEle	Text - Construction Element	0	0 / Continuous	1
	dsgnrd	TextCurveData	Text - Curve Data Note	0	0 / Continuous	2
	dsgnrd	TextDetails	Text - Detail Notes	4	0 / Continuous	2
	dsgnrd	TextDrainInvElev_ep	Text - Drainage Invert Elevation (Existing)	0	0 / Continuous	1
	dsgnrd	TextDrainLabel_ep	Text - Drainage (Existing)	0	0 / Continuous	1
	dsgnrd	TextElevLabel	Text - Elevation Labels	4	0 / Continuous	0
	dsgnrd	TextGeotech	Text - Soil Borings and Labels	0	0 / Continuous	2
	dsgnrd	TextLabel	Text - Label	0	0 / Continuous	2
	dsgnrd	TextLandscape	Text - Landscape Labels	0	0 / Continuous	1
	dsgnrd	TextMajor	Text - Major	0	0 / Continuous	5
	dsgnrd	TextMinor	Text - Minor	0	0 / Continuous	0
	dsgnrd	TextMisc	Text - Miscellaneous	0	0 / Continuous	1
	dsgnrd	TextNotes	Text - Notes	4	0 / Continuous	1
	dsgnrd	TextProfLabel	Text - Profile, Horizontal and Vertical Axis Labels	0	0 / Continuous	2
	dsgnrd	TextProjLabel	Text - Begin and End Project Label with Leader Lines	1	0 / Continuous	2
	dsgnrd	TextPtLabel	Text - Point Labels	4	0 / Continuous	0
	dsgnrd	TextShtNo	Text - Sheet Number	0	0 / Continuous	2
	dsgnrd	TextSubUtilLabel_ep	Text - Subsurface Utilities (Existing)	0	0 / Continuous	1
	dsgnrd	TextSurveyLabel	Text - Survey Labels	0	0 / Continuous	0
	dsgnrd	TextTables	Text - Key Sheet Indexes and Table Data	4	0 / Continuous	2
	dsgnrd	TextTitle	Text - Title	0	0 / Continuous	3
	dsgnrd	TextTopoLabel_ep	Text - Topography (Existing)	0	0 / Continuous	1
	dsgnrd	TextUtilLabel_ep	Text - Utilities (Existing)	0	0 / Continuous	1
	dsgnrd	TextXSBL_dp	Text - Cross Section Baseline Labels	0	0 / Continuous	2
	dsgnrd	TextXSDrain_ex	Text - Cross Section Drainage Labels (Existing)	10	0 / Continuous	2
	dsgnrd	TextXSDrain_px	Text - Cross Section Drainage Labels	10	0 / Continuous	2
	dsgnrd	TextXSElev	Text - Cross Section Elevations	2	0 / Continuous	1
	dsgnrd	TextXSElev_ex	Text - Cross Section Elevations (Existing)	2	0 / Continuous	1
	dsgnrd	TextXSElev_px	Text - Cross Section Elevations	0	0 / Continuous	1
	dsgnrd	TextXSGPKPts_dp	Text - Cross Section Points Labels	4	0 / Continuous	0
	dsgnrd	TextXSNotes_dp	Text - Cross Section Notes	0	0 / Continuous	2
	dsgnrd	TextXSSlope_dp	Text - Cross Section Slope Labels (rise:run format)	0	0 / Continuous	2
	dsgnrd	TextXSSlopePvt_dp	Text - Cross Section Pavement Slope Labels	0	0 / Continuous	2
X	dsgnrd	TmpDrpHndlStg1_dp	Template Drop Handle Display Setting on Corridor Design Stage 1	14	0 / Continuous	1
X	dsgnrd	TmpDrpHndlStg2_dp	Template Drop Handle Display Setting on Corridor Design Stage 2	10	0 / Continuous	1
X	dsgnrd	TmpDrpHndlStg3_dp	Template Drop Handle Display Setting on Corridor Design Stage 3	6	0 / Continuous	1
X	dsgnrd	TrafSeparator	Traffic Separator (All Types)	6	0 / Continuous	1
X	dsgnrd	TrafSeparator_ex	Traffic Separator on Cross Sections (All Types) (Existing)	6	2 / DGN2	1
X	dsgnrd	TrafSeparator_pm	Traffic Separator Top - Component Point Property and Model Break Line	6	0 / Continuous	1
X	dsgnrd	TrafSeparator_px	Traffic Separator on Cross Sections (All Types)	6	0 / Continuous	2

Critical	Rule	Level Name	Level Description	ByLevel Color	ByLevelStyle / Linetype	ByLevel Weight
X	dsgnrd	TrafSeparatorBase_px	Traffic Separator Subgrade on Cross Sections	3	0 / Continuous	2
X	dsgnrd	TranstionHndl_dp	Transition Handle Display Setting for All Design Stages	29	0 / Continuous	1
X	dsgnrd	TurbidityBarrier1	Turbidity Barrier 1 (Floating)	10	SWP-TurbidityBarrier-Type1	2
	dsgnrd	TurbidityBarrier1_ep	Turbidity Barrier 1 (Floating) (Existing)	10	1 / DGN1	2
X	dsgnrd	TurbidityBarrier2	Turbidity Barrier 2 (Staked)	10	SWP-TurbidityBarrier-Type2	2
	dsgnrd	TurbidityBarrier2_ep	Turbidity Barrier 2 (Staked) (Existing)	10	1 / DGN1	2
X	dsgnrd	Turf	Performance Turf	100	0 / Continuous	2
	dsgnrd	TurningEle_dp	Turning Radius Elements (Miscellaneous)	4	0 / Continuous	1
	dsgnrd	TurningRadius_dp	Turning Radius Line	3	3 / DGN3	1
	dsgnrd	TypicalMisc	Typical Items (Miscellaneous)	0	0 / Continuous	2
	dsgnrd	UtilsMisc_ex	Utility Items on Cross Sections (Miscellaneous) (Existing)	8	2 / DGN2	1
	dsgnrd	UtilsMisc_px	Utility Items on Cross Sections (Miscellaneous)	8	0 / Continuous	1
	dsgnrd	Vehicle	Vehicle for Calculating Turning Radius	7	0 / Continuous	2
	dsgnrd	Viewport	Viewport (For AutoCAD Use)	3	0 / Continuous	0
	dsgnrd	VoidArea_dx	Void Area on Cross Sections	1	0 / Continuous	0
X	dsgnrd	WallBarrier	Barrier Wall (All Types)	6	0 / Continuous	2
X	dsgnrd	WallBarrier_ex	Barrier Wall on Cross Section (Existing)	6	3 / DGN3	2
X	dsgnrd	WallBarrier_pm	Barrier Wall Top - Component Point Property and Model Break Line	6	0 / Continuous	1
X	dsgnrd	WallBarrier_px	Barrier Wall on Cross Sections	6	0 / Continuous	2
X	dsgnrd	WallFooter_pm	Wall Footer Top - Component Point Property and Model Break Line	2	0 / Continuous	1
X	dsgnrd	WallFooter_px	Wall Footer (Concrete) on Cross Sections - Component Symbology/Material on All Wall Footers/Leveling Pads	2	0 / Continuous	1
X	dsgnrd	WallGravBase_px	Gravity Wall Subgrade on Cross Sections	3	0 / Continuous	2
X	dsgnrd	WallGravity	Gravity Wall	11	0 / Continuous	1
X	dsgnrd	WallGravity_pm	Gravity Wall Top - Component Point Property and Model Break Line	11	0 / Continuous	1
X	dsgnrd	WallGravity_px	Gravity Wall on Cross Sections	11	0 / Continuous	2
X	dsgnrd	WallMedianBase_px	Median Wall Subgrade on Cross Sections	3	0 / Continuous	2
X	dsgnrd	WallNoise	Noise Wall (All Types)	11	0 / Continuous	2
X	dsgnrd	WallRetain	Retaining Wall System	6	0 / Continuous	1
X	dsgnrd	WallRetain_pm	Retaining Wall Top - Component Point Property and Model Break Line	6	0 / Continuous	1
X	dsgnrd	WallRetain_pr	Retaining Wall Profile	9	0 / Continuous	2
X	dsgnrd	WallRetain_px	Retaining Walls on Cross Sections	6	0 / Continuous	1
X	dsgnrd	WallShldrBase_px	Shoulder Wall Subgrade on Cross Sections	3	0 / Continuous	2
X	dsgnrd	Water_ex	Water on Cross Sections (Existing)	1	2 / DGN2	1
X	dsgnrd	Water_px	Water on Cross Sections	1	0 / Continuous	1
X	dsgnrd	WaterNP_ex	Raw Water Pipes on Cross Sections (Existing)	5	0 / Continuous	1
X	dsgnrd	WaterNP_px	Raw Water Pipes on Cross Sections	5	0 / Continuous	1
	dsgnrd	Wetland	Wetland Boundary	2	RD-Wetland-Proposed	1
	dsgnrd	Wetland_ex	Wetland Boundary on Cross Sections (Existing)	2	RD-Wetland-Existing	1
	dsgnrd	WetlandEdge_ep	Edge of Mangrove, Wetlands (Marsh or Swamp) (Existing)	2	RD-Wetland-Existing	0
	dsgnrd	Widening	Widening Patterns and Miscellaneous Elements	1	0 / Continuous	1
	dsgnrd	Xreference01_dp	Reference Files (For AutoCAD Use)	0	0 / Continuous	1
	dsgnrd	Xreference02_dp	Reference Files (For AutoCAD Use)	0	0 / Continuous	1
	dsgnrd	Xreference03_dp	Reference Files (For AutoCAD Use)	0	0 / Continuous	1
	dsgnrd	Xreference04_dp	Reference Files (For AutoCAD Use)	0	0 / Continuous	1
X	dsgnrd	XSBaseTop_px	Cross Section Top of Base	3	0 / Continuous	2
	dsgnrd	XSCell	GEOPAK Cross Section Cell/Block and Profile Cell/Block	8	0 / Continuous	1

Critical	Rule	Level Name	Level Description	ByLevel Color	ByLevelStyle / Linetype	ByLevel Weight
X	dsgnrd	XSExtendGrdLine_ex	Cross Section Extend Ground Lines (Existing)	21	2 / DGN2	1
X	dsgnrd	XSGrdLine_ex	Cross Section Ground Lines (Existing)	2	2 / DGN2	1
X	dsgnrd	XSGrdLine_px	Cross Section Roadway Ground Lines	1	0 / Continuous	2
	dsgnrd	XSMisc_ex	Cross Section Roadway Items (Miscellaneous (Existing))	4	3 / DGN3	1
	dsgnrd	XSMisc_px	Cross Section Items (Miscellaneous)	0	0 / Continuous	2
	dsgnrd	XSPt_ep	Cross Section Point, Station (Existing)	2	1 / DGN1	0
	dsgnrd	XSShapeDep01_dp	Cross Section Shape Dependent	11	0 / Continuous	2
	dsgnrd	XSShapeDep02_dp	Cross Section Shape Dependent	12	0 / Continuous	2
	dsgnrd	XSShapeDep03_dp	Cross Section Shape Dependent	13	0 / Continuous	2
	dsgnrd	XSShapeDep04_dp	Cross Section Shape Dependent	14	0 / Continuous	2
	dsgnrd	XSShapeDep05_dp	Cross Section Shape Dependent	15	0 / Continuous	2
	dsgnrd	XSShapeDep06_dp	Cross Section Shape Dependent	16	0 / Continuous	2
	dsgnrd	XSShapeDep07_dp	Cross Section Shape Dependent	17	0 / Continuous	2
	dsgnrd	XSShapeDep08_dp	Cross Section Shape Dependent	18	0 / Continuous	2
	dsgnrd	XSShapeDep09_dp	Cross Section Shape Dependent	19	0 / Continuous	2
	dsgnrd	XSShapeDep10_dp	Cross Section Shape Dependent	20	0 / Continuous	2
	dsgnrd	XSShapeIndep01_dp	Cross Section Shape Independent	1	0 / Continuous	2
	dsgnrd	XSShapeIndep02_dp	Cross Section Shape Independent	2	0 / Continuous	2
	dsgnrd	XSShapeIndep03_dp	Cross Section Shape Independent	3	0 / Continuous	2
	dsgnrd	XSShapeIndep04_dp	Cross Section Shape Independent	4	0 / Continuous	2
	dsgnrd	XSShapeIndep05_dp	Cross Section Shape Independent	5	0 / Continuous	2
	dsgnrd	XSShapeIndep06_dp	Cross Section Shape Independent	6	0 / Continuous	2
	dsgnrd	XSShapeIndep07_dp	Cross Section Shape Independent	7	0 / Continuous	2
	dsgnrd	XSShapeIndep08_dp	Cross Section Shape Independent	8	0 / Continuous	2
	dsgnrd	XSShapeIndep09_dp	Cross Section Shape Independent	9	0 / Continuous	2
	dsgnrd	XSShapeIndep10_dp	Cross Section Shape Independent	10	0 / Continuous	2
X	dsgnrd	XSTypical_px	Cross Section Roadway Pavement Typical	1	0 / Continuous	2

## DSGNSG - Signalization Design

Critical	Rule	Level Name	Level Description	ByLevel Color	ByLevelStyle / Linetype	ByLevel Weight
	dsgnsg	ActivePointCell_dp	Active Point Cell	4	0 / Continuous	10
	dsgnsg	AdhocPoint_dp	Adhoc Points Placed by SheetInfo	0	4 / DGN4	0
	dsgnsg	BaselineSurvey	Baseline Survey	0	0 / Continuous	2
	dsgnsg	CLConst_dp	Center Line of Construction	0	0 / Continuous	2
	dsgnsg	Cloud_dp	Construction Cloud	7	0 / Continuous	2
	dsgnsg	COGO_dp	COGO Information	3	0 / Continuous	1
X	dsgnsg	Conduit	Conduit for Utilities and Encasements	3	SG-Conduit	2
X	dsgnsg	ConduitAG	Conduit (Above Ground)	4	SG-ConduitAG-Proposed	1
X	dsgnsg	ConduitBM	Conduit – Bridge Mount	5	SG-ConduitBM-Proposed	1
X	dsgnsg	ConduitDB	Conduit – Directional Bore	2	SG-ConduitDB-Proposed	1
X	dsgnsg	ConduitJB	Conduit – Jack & Bore Under Rail	3	SG-ConduitJB-Proposed	1
X	dsgnsg	ConduitOT	Conduit – Open Trench	1	SG-ConduitOT-Proposed	1
	dsgnsg	ConstArea_dp	Construction Area Crosshatch	0	0 / Continuous	1
	dsgnsg	ConstLimits	Construction Limits	3	RW-LimitsofConst	2
	dsgnsg	ConstLines	Construction Lines and References	1	0 / Continuous	0
	dsgnsg	ConstLines_pm	Construction Lines	4	0 / Continuous	0

Critical	Rule	Level Name	Level Description	ByLevel Color	ByLevelStyle / Linetype	ByLevel Weight
X	dsgnsg	Controller	Controller and Accessories	0	0 / Continuous	2
X	dsgnsg	Controller_ep	Controller and Accessories (Existing)	0	2 / DGN2	1
X	dsgnsg	ControllerAccess	Controller Accessories	0	0 / Continuous	1
X	dsgnsg	ControllerB	Controller - Base Mounted	0	0 / Continuous	2
X	dsgnsg	ControllerB_ep	Controller - Base Mounted (Existing)	0	2 / DGN2	1
X	dsgnsg	ControllerP	Controller Pole Mount	0	0 / Continuous	2
X	dsgnsg	ControllerP_ep	Controller Pole Mount (Existing)	0	2 / DGN2	1
	dsgnsg	CurveData_dp	Curve & Coordinate Data Elements Including PC, PT, PI Symbols	4	0 / Continuous	2
	dsgnsg	CurveDataLabel_dp	Curve Data Labels PC,PI, PT	0	0 / Continuous	2
X	dsgnsg	Delineator	Delineators (All Types)	4	0 / Continuous	1
X	dsgnsg	Detector	Detector Cabinet, Button and Miscellaneous Assemblies	3	0 / Continuous	2
X	dsgnsg	DetectorVeh	Detector Vehicle Assemblies (All Types)	3	0 / Continuous	1
	dsgnsg	DimLines_dp	Dimension Lines, Corresponding Terminators, Equation Lines	0	0 / Continuous	1
X	dsgnsg	EaseLicLine	Easement License Agreement Line	5	6 / DGN6	0
X	dsgnsg	ElecBur	Electrical (Buried)	3	UT-BuriedElec-Proposed	2
X	dsgnsg	ElecServ	Electrical Service (Miscellaneous)	3	0 / Continuous	2
X	dsgnsg	ElecServWire	Electrical Service Wire	3	0 / Continuous	2
X	dsgnsg	FOCBur	Fiber Optics Cable (Buried)	6	UT-BuriedFOC-Proposed	2
	dsgnsg	GridMaj_dp	Grid Lines Major in Profile and Cross Section	3	0 / Continuous	1
	dsgnsg	GridMin_dp	Grid Lines Minor in Profile and Cross Section	0	0 / Continuous	0
	dsgnsg	GridMinSub_dp	Grid Lines Minor Sub on Cross Section Sheets	20	0 / Continuous	0
	dsgnsg	GSBWFill	GuidSign Black and White Fill Level for GuidSign Cells	0	0 / Continuous	1
	dsgnsg	GSColorFill	GuidSign Color Fill Level for GuidSign Cells	2	0 / Continuous	1
	dsgnsg	GSDims	GuidSign Dimensions	0	0 / Continuous	1
	dsgnsg	GSOOutline	GuidSign Outline Level for GuidSign Cells	0	0 / Continuous	2
	dsgnsg	GSSign	GuidSign Panel and Tag	7	0 / Continuous	0
X	dsgnsg	GuyWire	Guy Wire	3	0 / Continuous	2
	dsgnsg	ImageAttachment_dp	Image Attachments	0	0 / Continuous	0
	dsgnsg	InRoadLight	In-Roadway Light Assembly	0	0 / Continuous	2
X	dsgnsg	Insulator	Insulator, Fiberglass	3	0 / Continuous	4
X	dsgnsg	InterconCable	Cable Interconnect	1	SG-InterconCable-Proposed	1
X	dsgnsg	InterconCable_ep	Interconnect Cable (Existing)	1	SG-InterconCable-Existing	0
X	dsgnsg	JunctBox	Junction Boxes, Service Cabinet (Elec/Tel)	3	0 / Continuous	2
	dsgnsg	JunctBox_ep	Junction Box / Service Cabinet (Elec/Tel) (Existing)	3	1 / DGN1	1
X	dsgnsg	JunctBoxA	Junction Boxes (Aerial)	3	0 / Continuous	1
X	dsgnsg	JunctBoxA_ep	Junction Boxes (Aerial) (Existing)	3	1 / DGN1	0
	dsgnsg	LaneDirArrow	Lane Directional Arrow	0	0 / Continuous	1
	dsgnsg	LeaderLine_dp	Leader Line and Terminator with Text	0	0 / Continuous	1
X	dsgnsg	LoadCenter	Load Center	2	0 / Continuous	1
X	dsgnsg	LoadCenter_ep	Load Center (Existing)	2	5 / DGN5	0
	dsgnsg	Logo_dp	Consultant Engineer of Record Logo	0	0 / Continuous	1
X	dsgnsg	LoopLI	Loop Lead-In	3	0 / Continuous	1
X	dsgnsg	LoopLI_ep	Loop Lead-In (Existing)	3	2 / DGN2	0
X	dsgnsg	Loops	Loop Assembly (All Types)	2	0 / Continuous	2
X	dsgnsg	Loops_ep	Loop Assembly (All Types) (Existing)	2	2 / DGN2	2
	dsgnsg	MatchLines_dp	Match Lines with Text, Arrows for Station Notations	1	0 / Continuous	2



Critical	Rule	Level Name	Level Description	ByLevel Color	ByLevelStyle / Linetype	ByLevel Weight
X	dsgnsg	MessengerWire	Messenger Wire	3	0 / Continuous	1
	dsgnsg	Miscellaneous0	Undefined Proposed Item - Color Blue Weight 0	1	0 / Continuous	0
	dsgnsg	Miscellaneous1	Undefined Proposed Item - Color Blue Weight 1	1	0 / Continuous	1
	dsgnsg	Miscellaneous2	Undefined Proposed Item - Color Blue Weight 2	1	0 / Continuous	2
	dsgnsg	Miscellaneous3	Undefined Proposed Item - Color Green Weight 0	2	0 / Continuous	0
	dsgnsg	Miscellaneous4	Undefined Proposed Item - Color Green Weight 1	2	0 / Continuous	1
	dsgnsg	Miscellaneous5	Undefined Proposed Item - Color Green Weight 2	2	0 / Continuous	2
	dsgnsg	Miscellaneous6	Undefined Proposed Item - Color Red Weight 0	3	0 / Continuous	0
	dsgnsg	Miscellaneous7	Undefined Proposed Item - Color Red Weight 1	3	0 / Continuous	1
	dsgnsg	Miscellaneous8	Undefined Proposed Item - Color Red Weight 2	3	0 / Continuous	2
	dsgnsg	Miscellaneous9	Undefined Proposed Item - Color Red Weight 3	3	0 / Continuous	3
	dsgnsg	NonPlottingEle_dp	Non-Plotting Items - Construction Elements, Type 66 Elements, Etc.	4	0 / Continuous	0
	dsgnsg	NorthArw_dp	North Arrows	0	0 / Continuous	2
X	dsgnsg	ObjectMarker	Object and Reflective Markers	3	0 / Continuous	1
X	dsgnsg	OverheadSign	Overhead Sign Panels	0	0 / Continuous	2
X	dsgnsg	OverheadSign_ep	Overhead Sign Panels (Existing)	0	3 / DGN3	1
X	dsgnsg	OverheadStr	Mast Arm, Truss Assemblies, Signal Arms and Supports	0	0 / Continuous	2
X	dsgnsg	OverheadStr_ep	Mast Arm, Truss Assemblies, Signal Arms and Supports (Existing)	0	3 / DGN3	1
X	dsgnsg	PavtMessage	Pavement Message (All Types)	0	0 / Continuous	1
X	dsgnsg	PavtMessage_ep	Pavement Message (All Types) (Existing)	0	2 / DGN2	0
	dsgnsg	PayItem_dp	Pay Item Number Label Elements	4	0 / Continuous	2
X	dsgnsg	PedDetector	Pedestrian Detector	0	0 / Continuous	2
X	dsgnsg	Pedestal	Pedestal	1	0 / Continuous	1
X	dsgnsg	Pedestal_ep	Pedestal (Existing)	1	2 / DGN2	1
X	dsgnsg	PedHead	Pedestrian Head (All Types)	1	0 / Continuous	1
X	dsgnsg	PedHead_ep	Pedestrian Head (All Types) (Existing)	0	2 / DGN2	1
X	dsgnsg	PlotBorder_dp	Plot Border	3	0 / Continuous	0
X	dsgnsg	PMCeramic	Pavement Markers Ceramic	0	0 / Continuous	1
	dsgnsg	PMMisc	Pavement Marking Items (Miscellaneous)	0	0 / Continuous	2
X	dsgnsg	PMStripe(10-10-20)	Pavement Marking 10/10/20 Skip Traffic Stripe 6in Contrast	0	PM-Stripe-10'_20'Skip / PM-Stripe-SKIP 10-10-20	2
X	dsgnsg	PMStripe(2-2-2)	Pavement Marking 2/2/2 Skip Traffic Stripe 6in Contrast	0	PM-Stripe-2'_2'Skip / PM-Stripe-SKIP 2-2-2	2
X	dsgnsg	PMStripe12B	Pavement Marking Traffic Stripe 12in Black	3	0 / Continuous	4
X	dsgnsg	PMStripe12W	Pavement Marking Traffic Stripe 12in White	0	0 / Continuous	4
X	dsgnsg	PMStripe12W(2-4)	Pavement Marking 2/4 Skip Traffic Stripe 12in White	0	0 / PM-Stripe-SKIP 2-4	4
X	dsgnsg	PMStripe12W(3-9)	Pavement Marking 3/9 Skip Traffic Stripe 12in White	0	0 / PM-Stripe-SKIP 3-9	4
X	dsgnsg	PMStripe12Y	Pavement Marking Traffic Stripe 12in Yellow	4	0 / Continuous	4
X	dsgnsg	PMStripe16B	Pavement Marking Traffic Stripe 16in Black	3	0 / Continuous	5
X	dsgnsg	PMStripe16W	Pavement Marking Traffic Stripe 16in White	0	0 / Continuous	5
X	dsgnsg	PMStripe16Y	Pavement Marking Traffic Stripe 16in Yellow	4	0 / Continuous	5
X	dsgnsg	PMStripe18B	Pavement Marking Traffic Stripe 18in Black	3	0 / Continuous	6
X	dsgnsg	PMStripe18W	Pavement Marking Traffic Stripe 18in White	0	0 / Continuous	6
X	dsgnsg	PMStripe18Y	Pavement Marking Traffic Stripe 18in Yellow	4	0 / Continuous	6
X	dsgnsg	PMStripe24W	Pavement Marking Traffic Stripe 24in White	0	0 / Continuous	7
X	dsgnsg	PMStripe24Y	Pavement Marking Traffic Stripe 24in Yellow	4	0 / Continuous	7
X	dsgnsg	PMStripe6B	Pavement Marking Traffic Stripe 6in Black	3	0 / Continuous	2
X	dsgnsg	PMStripe6B(10-30)	Pavement Marking 10/30 Skip Traffic Stripe 6in Black	3	0 / PM-Stripe-SKIP 10-30	2

Critical	Rule	Level Name	Level Description	ByLevel Color	ByLevelStyle / Linetype	ByLevel Weight
X	dsgnsg	PMStripe6Bl	Pavement Marking Traffic Stripe 6in Blue	1	0 / Continuous	2
X	dsgnsg	PMStripe6DY	Pavement Marking Traffic Stripe 6in Double Yellow	4	0 / Continuous	2
X	dsgnsg	PMStripe6W	Pavement Marking Traffic Stripe 6in White	0	0 / Continuous	2
X	dsgnsg	PMStripe6W(10-30)	Pavement Marking 10/30 Skip Traffic Stripe 6in White	0	0 /PM-Stripe-SKIP 10-30	2
X	dsgnsg	PMStripe6W(2-4)	Pavement Marking 2/4 Skip Traffic Stripe 6in White	0	0 /PM-Stripe-SKIP 2-4	2
X	dsgnsg	PMStripe6W(3-9)	Pavement Marking 3/9 Skip Traffic Stripe 6in White	0	0 /PM-Stripe-SKIP 3-9	2
X	dsgnsg	PMStripe6W(6-10)	Pavement Marking 6/10 Skip Traffic Stripe 6in White	0	0 /PM-Stripe-SKIP 6-10	2
X	dsgnsg	PMStripe6Y	Pavement Marking Traffic Stripe 6in Yellow	4	0 / Continuous	2
X	dsgnsg	PMStripe6Y(10-30)	Pavement Marking 10/30 Skip Traffic Stripe 6in Yellow	4	0 /PM-Stripe-SKIP 10-30	2
X	dsgnsg	PMStripe6Y(2-4)	Pavement Marking 2/4 Skip Traffic Stripe 6in Yellow	4	0 /PM-Stripe-SKIP 2-4	2
X	dsgnsg	PMStripe6Y(6-10)	Pavement Marking 6/10 Skip Traffic Stripe 6in Yellow	4	0 /PM-Stripe-SKIP 6-10	2
X	dsgnsg	PMStripe8B	Pavement Marking Traffic Stripe 8in Black	3	0 / Continuous	3
X	dsgnsg	PMStripe8W	Pavement Marking Traffic Stripe 8in White	0	0 / Continuous	3
X	dsgnsg	PMStripe8W(3-9)	Pavement Marking 3/9 Skip Traffic Stripe 8in White	0	0 /PM-Stripe-SKIP 3-9	2
X	dsgnsg	PMStripe8Y	Pavement Marking Traffic Stripe 8in Yellow	4	0 / Continuous	3
X	dsgnsg	PMStripe9C(10-30)	Pavement Marking 10/30 Skip Traffic Stripe 9in Contrast	0	0 / PM-Stripe-SKIP 10-30	2
X	dsgnsg	PMStripeRumbleCL	Center Line Rumble Stripes (Use to Quantify Rumble Strips) (NonPlotting)	4	PM-Stripe-RumbleStripeLeft / PM-Stripe-RumbleStripe	2
X	dsgnsg	PMStripeRumbleWL	Rumble Stripes (6in White Thermoplastic Over Rumble Strips) (Left)	0	PM-Stripe-RumbleStripeLeft / PM-Stripe-RumbleStripe	2
X	dsgnsg	PMStripeRumbleWR	Rumble Stripes (6in White Thermoplastic Over Rumble Strips) (Right)	0	PM-Stripe-RumbleStripeRight / PM-Stripe-RumbleStripe	2
X	dsgnsg	PMStripeRumbleYL	Rumble Stripes (6in Yellow Thermoplastic Over Rumble Strips) (Left)	4	PM-Stripe-RumbleStripeLeft / PM-Stripe-RumbleStripe	2
X	dsgnsg	PMStripeRumbleYR	Rumble Stripes (6in Yellow Thermoplastic Over Rumble Strips) (Right)	4	PM-Stripe-RumbleStripeRight / PM-Stripe-RumbleStripe	2
X	dsgnsg	PMStripeVibeWL	Pavement Marking Auditory and Vibratory 6in White (Left)	0	PM-Stripe-VibratoryLeft /PM-Stripe-Vibratory	2
X	dsgnsg	PMStripeVibeWR	Pavement Marking Auditory and Vibratory 6in White (Right)	0	PM-Stripe-VibratoryRight /PM-Stripe-Vibratory	2
X	dsgnsg	PMStripeVibeYL	Pavement Marking Auditory and Vibratory 6in Yellow (Left)	4	PM-Stripe-VibratoryLeft /PM-Stripe-Vibratory	2
X	dsgnsg	PMStripeVibeYR	Pavement Marking Auditory and Vibratory 6in Yellow (Right)	4	PM-Stripe-VibratoryRight /PM-Stripe-Vibratory	2
	dsgnsg	PointLocator_ep	Point Locator Symbol (Existing)	4	0 / Continuous	0
X	dsgnsg	PoleConc	Concrete Strain Pole	0	0 / Continuous	2
X	dsgnsg	PoleConc_ep	Concrete Strain Pole (Existing)	0	2 / DGN2	1
X	dsgnsg	PoleElec	Electrical Pole w/ Transformer	3	0 / Continuous	2
X	dsgnsg	PoleFound	Pole Foundation	0	0 / Continuous	2
X	dsgnsg	PoleLight	Light Pole	2	0 / Continuous	1
X	dsgnsg	PoleLight_ep	Light Pole (Existing)	2	2 / DGN2	1
X	dsgnsg	PoleLightHM	High Mast Light Pole	3	0 / Continuous	1
X	dsgnsg	PoleLightHM_ep	High Mast Light Pole (Existing)	2	2 / DGN2	1
	dsgnsg	PoleLightID	Light Pole Location / ID	4	0 / Continuous	1
X	dsgnsg	PoleShared	Power Pole Electric (Above Ground) Shared w/ Transformer	3	0 / Continuous	2
X	dsgnsg	PoleSteelStrain	Steel Strain Pole	0	0 / Continuous	2
X	dsgnsg	PoleSteelStrain_ep	Steel Strain Pole (Existing)	0	2 / DGN2	1
X	dsgnsg	PoleTel	Telephone Pole	6	0 / Continuous	2
X	dsgnsg	PoleUtil	Utility Pole	0	0 / Continuous	2
X	dsgnsg	PoleWoodStrain	Wood Strain Pole	0	0 / Continuous	2
X	dsgnsg	PoleWoodStrain_ep	Wood Strain Pole (Existing)	0	2 / DGN2	1
X	dsgnsg	PullBox	Pull Boxes (All Types)	3	0 / Continuous	1



Critical	Rule	Level Name	Level Description	ByLevel Color	ByLevelStyle / Linetype	ByLevel Weight
	dsgnsg	PullBox_ep	Wiring Pull Box (Existing)	3	1 / DGN1	1
	dsgnsg	ReferencePt_dp	Survey and Construction Reference Point Details and Elements	4	0 / Continuous	2
X	dsgnsg	SawCuts	Saw Cuts	3	3 / DGN3	0
	dsgnsg	Scale_dp	Bar Scale, Scale Label Elements	0	0 / Continuous	2
	dsgnsg	Scratch1_dp	Scratch Level for Temporary or Informational Items	4	0 / Continuous	0
	dsgnsg	Scratch2_dp	Scratch Level for Temporary or Informational Items	5	0 / Continuous	0
	dsgnsg	ScratchEle_dp	Scratch Level for Draft Elements, Temporary Elements, Etc. (DO NOT PLOT)	3	0 / Continuous	0
	dsgnsg	ScratchEle2_dp	Scratch Level for Draft Elements, Temporary Elements, Etc. (DO NOT PLOT)	4	0 / Continuous	0
	dsgnsg	SheetBorder_dp	Sheet Border	1	0 / Continuous	4
	dsgnsg	SheetLines_dp	Sheet Lines	1	0 / Continuous	2
	dsgnsg	SheetLinesMisc1_dp	Sheet Lines	1	0 / Continuous	0
	dsgnsg	SheetLinesMisc2_dp	Sheet Lines	2	0 / Continuous	2
	dsgnsg	SheetLinesMisc3_dp	Sheet Lines	3	0 / Continuous	2
	dsgnsg	SheetLinesMisc4_dp	Sheet Lines	4	0 / Continuous	2
X	dsgnsg	SignalCable	Signal Cable	3	SG-Cable / Continuous	1
X	dsgnsg	SignalCableAccs	Signal Cable Accessories	0	0 / Continuous	2
X	dsgnsg	SignalDetail	Signal Details	0	0 / Continuous	1
	dsgnsg	SignalHead	Signal Head Section Details	2	0 / Continuous	1
X	dsgnsg	SignalHead_ep	Signal Head Section Details (Existing)	2	2 / DGN2	0
	dsgnsg	SignalMisc	Signal Equipment (Miscellaneous)	3	0 / Continuous	1
X	dsgnsg	SignalSOP	S.O.P. Box and Movements	0	0 / Continuous	2
X	dsgnsg	SignalSym	Signal Head Symbols	0	0 / Continuous	1
X	dsgnsg	SignalSym_ep	Signal Head Symbols (Existing)	3	2 / DGN2	0
X	dsgnsg	SignCantilever	Sign Symbol Cantilever	0	0 / Continuous	1
X	dsgnsg	SignCantilever_ep	Sign Symbol Cantilever (Existing)	0	2 / DGN2	0
	dsgnsg	SignDetail	Sign Details	0	0 / Continuous	2
X	dsgnsg	SignDMS	Dynamic Message Sign	0	0 / Continuous	1
	dsgnsg	SignLettersAZ	Alphabet Cell Library Letter A-Z Numbers 0-9	0	0 / Continuous	0
	dsgnsg	SignMisc	Sign Symbols (Miscellaneous)	3	0 / Continuous	1
	dsgnsg	SignMisc_ep	Sign Symbols (Miscellaneous ) (Existing)	1	1 / DGN1	1
X	dsgnsg	SignPanel	Sign Panels - Regulatory	0	0 / Continuous	2
X	dsgnsg	SignPanel_ep	Sign Panel Elements (Existing)	0	2 / DGN2	1
X	dsgnsg	SignPanelBorder	Sign Panel Border on Sign Details	0	0 / Continuous	1
X	dsgnsg	SignPanelC	Sign Panels - Civil	1	0 / Continuous	2
X	dsgnsg	SignPanelDetRed	Sign Panel Details in Red	3	0 / Continuous	2
X	dsgnsg	SignPanelG	Sign Panels - Guide	2	0 / Continuous	2
X	dsgnsg	SignPanell	Sign Panels - Special Interest	9	0 / Continuous	2
X	dsgnsg	SignPanelT	Sign Panels - Construction	6	0 / Continuous	2
X	dsgnsg	SignPanelW	Sign Panels - Warning	4	0 / Continuous	2
X	dsgnsg	SignSpanwire	Span Wire Signing Assembly	2	0 / Continuous	1
X	dsgnsg	SignSpanwire_ep	Span Wire Signing Assembly (Existing)	2	2 / DGN2	1
X	dsgnsg	SignSpecial	Special Signs / Guide Signs	2	0 / Continuous	2
X	dsgnsg	SignSupport	Ground Mounted Sign Support Symbol (All Types)	1	0 / Continuous	1
X	dsgnsg	SignSymbol_px	Sign Structure and Foundation on Cross Sections	4	0 / Continuous	2
X	dsgnsg	SignTruss	Sign Symbol Truss	3	0 / Continuous	1
X	dsgnsg	SignTruss_ep	Sign Symbol Truss (Existing)	3	2 / DGN2	1

Critical	Rule	Level Name	Level Description	ByLevel Color	ByLevelStyle / Linetype	ByLevel Weight
	dsgnsg	SpecialDetails	Special Details	6	0 / Continuous	1
	dsgnsg	StationTicL_dp	Station Tic Marks (Large) and Text	0	0 / Continuous	2
	dsgnsg	StationTicS_dp	Station Tic Marks (Small) and Text	0	0 / Continuous	2
	dsgnsg	SumBoxBorder_dp	Summary Boxes Borders	4	0 / Continuous	3
	dsgnsg	SumBoxLines_dp	Summary Boxes Lines and Miscellaneous Items	4	0 / Continuous	1
	dsgnsg	SumBoxLinesMin_dp	Summary Boxes Lines Minor Line and Miscellaneous Items	4	0 / Continuous	0
	dsgnsg	Tables_dp	Data Tables and All Autodesk Tables	0	0 / Continuous	1
	dsgnsg	TextBLStation	Text - B/L Station and Tics	0	0 / Continuous	2
	dsgnsg	TextConstEle	Text - Construction Element	0	0 / Continuous	1
	dsgnsg	TextCurveData	Text - Curve Data Note	0	0 / Continuous	2
	dsgnsg	TextDetails	Text - Detail Notes	4	0 / Continuous	2
	dsgnsg	TextDrainInvElev_ep	Text - Drainage Invert Elevation (Existing)	0	0 / Continuous	1
	dsgnsg	TextDrainLabel_ep	Text - Drainage (Existing)	0	0 / Continuous	1
	dsgnsg	TextElevLabel	Text - Elevation Labels	4	0 / Continuous	0
	dsgnsg	TextLabel	Text - Label	0	0 / Continuous	2
	dsgnsg	TextLandscape	Text - Landscape Labels	0	0 / Continuous	1
	dsgnsg	TextMajor	Text - Major	0	0 / Continuous	5
	dsgnsg	TextMinor	Text - Minor	0	0 / Continuous	0
	dsgnsg	TextMisc	Text - Miscellaneous	0	0 / Continuous	1
	dsgnsg	TextNotes	Text - Notes	4	0 / Continuous	1
	dsgnsg	TextProfLabel	Text - Profile, Horizontal and Vertical Axis Labels	0	0 / Continuous	2
	dsgnsg	TextProjLabel	Text - Begin and End Project Label with Leader Lines	1	0 / Continuous	2
	dsgnsg	TextPtLabel	Text - Point Labels	4	0 / Continuous	0
	dsgnsg	TextShtNo	Text - Sheet Number	0	0 / Continuous	2
	dsgnsg	TextSubUtilLabel_ep	Text - Subsurface Utilities (Existing)	0	0 / Continuous	1
	dsgnsg	TextSurveyLabel	Text - Survey Labels	0	0 / Continuous	0
	dsgnsg	TextTables	Text - Key Sheet Indexes and Table Data	4	0 / Continuous	2
	dsgnsg	TextTitle	Text - Title	0	0 / Continuous	3
	dsgnsg	TextTopoLabel_ep	Text - Topography (Existing)	0	0 / Continuous	1
	dsgnsg	TextUtilLabel_ep	Text - Utilities (Existing)	0	0 / Continuous	1
	dsgnsg	TextXSElev	Text - Cross Section Elevations	2	0 / Continuous	1
	dsgnsg	Viewport	Viewport (For AutoCAD Use)	3	0 / Continuous	0
	dsgnsg	Xreference01_dp	Reference Files (For AutoCAD Use)	0	0 / Continuous	1
	dsgnsg	Xreference02_dp	Reference Files (For AutoCAD Use)	0	0 / Continuous	1
	dsgnsg	Xreference03_dp	Reference Files (For AutoCAD Use)	0	0 / Continuous	1
	dsgnsg	Xreference04_dp	Reference Files (For AutoCAD Use)	0	0 / Continuous	1
	dsgnsg	XSCell	GEOPAK Cross Section Cell/Block and Profile Cell/Block	8	0 / Continuous	1

## DSGNSP - Signing and Pavement Marking Design

Critical	Rule	Level Name	Level Description	ByLevel Color	ByLevelStyle / Linetype	ByLevel Weight
	dsgnsp	ActivePointCell_dp	Active Point Cell	4	0 / Continuous	10
	dsgnsp	AdhocPoint_dp	Adhoc Points Placed by SheetInfo	0	4 / DGN4	0
	dsgnsp	BaselineSurvey	Baseline Survey	0	0 / Continuous	2
X	dsgnsp	BikeLaneColorPavt	Green Bike Lane Pavement	2	0 / Continuous	2
	dsgnsp	CLConst_dp	Center Line of Construction	0	0 / Continuous	2
	dsgnsp	Cloud_dp	Construction Cloud	7	0 / Continuous	2
	dsgnsp	COGO_dp	COGO Information	3	0 / Continuous	1
X	dsgnsp	ConduitAG	Conduit (Above Ground)	4	SG-ConduitAG-Proposed	1
X	dsgnsp	ConduitBM	Conduit – Bridge Mount	5	SG-ConduitBM-Proposed	1
X	dsgnsp	ConduitDB	Conduit – Directional Bore	2	SG-ConduitDB-Proposed	1
X	dsgnsp	ConduitJB	Conduit – Jack & Bore Under Rail	3	SG-ConduitJB-Proposed	1
X	dsgnsp	ConduitOT	Conduit – Open Trench	1	SG-ConduitOT-Proposed	1
	dsgnsp	ConstArea_dp	Construction Area Crosshatch	0	0 / Continuous	1
	dsgnsp	ConstLimits	Construction Limits	3	RW-LimitsofConst	2
	dsgnsp	ConstLines	Construction Lines and References	1	0 / Continuous	0
	dsgnsp	ConstLines_pm	Construction Lines	4	0 / Continuous	0
X	dsgnsp	CrossWalk1	Emphasis Crosswalk 6ft High	0	PM-Stripe-6' Crosswalk	4
X	dsgnsp	CrossWalk2	Emphasis Crosswalk 10ft High	0	PM-Stripe-10' Crosswalk	4
	dsgnsp	CurveData_dp	Curve & Coordinate Data Elements Including PC, PT, PI Symbols	4	0 / Continuous	2
	dsgnsp	CurveDataLabel_dp	Curve Data Labels PC,PI, PT	0	0 / Continuous	2
X	dsgnsp	Delineator	Delineators (All Types)	4	0 / Continuous	1
	dsgnsp	DimLines_dp	Dimension Lines, Corresponding Terminators, Equation Lines	0	0 / Continuous	1
X	dsgnsp	DirArrowsPavt	Pavement Marking Directional Arrows	0	0 / Continuous	1
X	dsgnsp	EaseLicLine	Easement License Agreement Line	5	6 / DGN6	0
	dsgnsp	GridMaj_dp	Grid Lines Major in Profile and Cross Section	3	0 / Continuous	1
	dsgnsp	GridMin_dp	Grid Lines Minor in Profile and Cross Section	0	0 / Continuous	0
	dsgnsp	GridMinSub_dp	Grid Lines Minor Sub on Cross Section Sheets	20	0 / Continuous	0
	dsgnsp	GSBWFill	GuidSign Black and White Fill Level for GuidSign Cells	0	0 / Continuous	1
	dsgnsp	GSColorFill	GuidSign Color Fill Level for GuidSign Cells	2	0 / Continuous	1
	dsgnsp	GSDims	GuidSign Dimensions	0	0 / Continuous	1
	dsgnsp	GSOuline	GuidSign Outline Level for GuidSign Cells	0	0 / Continuous	2
	dsgnsp	GSSign	GuidSign Panel and Tag	7	0 / Continuous	0
	dsgnsp	ImageAttachment_dp	Image Attachments	0	0 / Continuous	0
	dsgnsp	InRoadLight	In-Roadway Light Assembly	0	0 / Continuous	2
	dsgnsp	LaneDirArrow	Lane Directional Arrow	0	0 / Continuous	1
	dsgnsp	LeaderLine_dp	Leader Line and Terminator with Text	0	0 / Continuous	1
	dsgnsp	Logo_dp	Consultant Engineer of Record Logo	0	0 / Continuous	1
	dsgnsp	MatchLines_dp	Match Lines with Text, Arrows for Station Notations	1	0 / Continuous	2
X	dsgnsp	MetalButtons	Metal Buttons	0	0 / Continuous	2
	dsgnsp	Miscellaneous0	Undefined Proposed Item - Color Blue Weight 0	1	0 / Continuous	0
	dsgnsp	Miscellaneous1	Undefined Proposed Item - Color Blue Weight 1	1	0 / Continuous	1
	dsgnsp	Miscellaneous2	Undefined Proposed Item - Color Blue Weight 2	1	0 / Continuous	2
	dsgnsp	Miscellaneous3	Undefined Proposed Item - Color Green Weight 0	2	0 / Continuous	0
	dsgnsp	Miscellaneous4	Undefined Proposed Item - Color Green Weight 1	2	0 / Continuous	1

Critical	Rule	Level Name	Level Description	ByLevel Color	ByLevelStyle / Linetype	ByLevel Weight
	dsgnsp	Miscellaneous5	Undefined Proposed Item - Color Green Weight 2	2	0 / Continuous	2
	dsgnsp	Miscellaneous6	Undefined Proposed Item - Color Red Weight 0	3	0 / Continuous	0
	dsgnsp	Miscellaneous7	Undefined Proposed Item - Color Red Weight 1	3	0 / Continuous	1
	dsgnsp	Miscellaneous8	Undefined Proposed Item - Color Red Weight 2	3	0 / Continuous	2
	dsgnsp	Miscellaneous9	Undefined Proposed Item - Color Red Weight 3	3	0 / Continuous	3
	dsgnsp	NonPlottingEle_dp	Non-Plotting Items - Construction Elements, Type 66 Elements, Etc.	4	0 / Continuous	0
	dsgnsp	NorthArw_dp	North Arrows	0	0 / Continuous	2
X	dsgnsp	ObjectMarker	Object and Reflective Markers	3	0 / Continuous	1
X	dsgnsp	OverheadSign	Overhead Sign Panels	0	0 / Continuous	2
X	dsgnsp	OverheadSign_ep	Overhead Sign Panels (Existing)	0	3 / DGN3	1
X	dsgnsp	OverheadStr	Mast Arm, Truss Assemblies, Signal Arms and Supports	0	0 / Continuous	2
X	dsgnsp	OverheadStr_ep	Mast Arm, Truss Assemblies, Signal Arms and Supports (Existing)	0	3 / DGN3	1
	dsgnsp	Pavemk_ep	Pavement Markings (All) (Existing)	0	2 / DGN2	0
X	dsgnsp	PavtMessage	Pavement Message (All Types)	0	0 / Continuous	1
X	dsgnsp	PavtMessage_ep	Pavement Message (All Types) (Existing)	0	2 / DGN2	0
	dsgnsp	PayItem_dp	Pay Item Number Label Elements	4	0 / Continuous	2
X	dsgnsp	PlotBorder_dp	Plot Border	3	0 / Continuous	0
X	dsgnsp	PMCeramic	Pavement Markers Ceramic	0	0 / Continuous	1
	dsgnsp	PMMisc	Pavement Marking Items (Miscellaneous)	0	0 / Continuous	2
X	dsgnsp	PMStripe(10-10-20)	Pavement Marking 10/10/20 Skip Traffic Stripe 6in Contrast	0	PM-Stripe-10_20'Skip /PM-Stripe-SKIP 10-10-20	2
X	dsgnsp	PMStripe(2-2-2)	Pavement Marking 2/2/2 Skip Traffic Stripe 6in Contrast	0	PM-Stripe-2_2'Skip / PM-Stripe-SKIP 2-2-2	2
X	dsgnsp	PMStripe12B	Pavement Marking Traffic Stripe 12in Black	3	0 / Continuous	4
X	dsgnsp	PMStripe12W	Pavement Marking Traffic Stripe 12in White	0	0 / Continuous	4
X	dsgnsp	PMStripe12W(2-4)	Pavement Marking 2/4 Skip Traffic Stripe 12in White	0	0 / PM-Stripe-SKIP 2-4	4
X	dsgnsp	PMStripe12W(3-9)	Pavement Marking 3/9 Skip Traffic Stripe 12in White	0	0 /PM-Stripe-SKIP 3-9	4
X	dsgnsp	PMStripe12Y	Pavement Marking Traffic Stripe 12in Yellow	4	0 / Continuous	4
X	dsgnsp	PMStripe16B	Pavement Marking Traffic Stripe 16in Black	3	0 / Continuous	5
X	dsgnsp	PMStripe16W	Pavement Marking Traffic Stripe 16in White	0	0 / Continuous	5
X	dsgnsp	PMStripe16Y	Pavement Marking Traffic Stripe 16in Yellow	4	0 / Continuous	5
X	dsgnsp	PMStripe18B	Pavement Marking Traffic Stripe 18in Black	3	0 / Continuous	6
X	dsgnsp	PMStripe18W	Pavement Marking Traffic Stripe 18in White	0	0 / Continuous	6
X	dsgnsp	PMStripe18Y	Pavement Marking Traffic Stripe 18in Yellow	4	0 / Continuous	6
X	dsgnsp	PMStripe24W	Pavement Marking Traffic Stripe 24in White	0	0 / Continuous	7
X	dsgnsp	PMStripe24Y	Pavement Marking Traffic Stripe 24in Yellow	4	0 / Continuous	7
X	dsgnsp	PMStripe6B	Pavement Marking Traffic Stripe 6in Black	3	0 / Continuous	2
X	dsgnsp	PMStripe6B(10-30)	Pavement Marking 10/30 Skip Traffic Stripe 6in Black	3	0 /PM-Stripe-SKIP 10-30	2
X	dsgnsp	PMStripe6Bl	Pavement Marking Traffic Stripe 6in Blue	1	0 / Continuous	2
X	dsgnsp	PMStripe6DY	Pavement Marking Traffic Stripe 6in Double Yellow	4	0 / Continuous	2
X	dsgnsp	PMStripe6W	Pavement Marking Traffic Stripe 6in White	0	0 / Continuous	2
X	dsgnsp	PMStripe6W(10-30)	Pavement Marking 10/30 Skip Traffic Stripe 6in White	0	0 / PM-Stripe-SKIP 10-30	2
X	dsgnsp	PMStripe6W(2-4)	Pavement Marking 2/4 Skip Traffic Stripe 6in White	0	0 /PM-Stripe-SKIP 2-4	2
X	dsgnsp	PMStripe6W(3-9)	Pavement Marking 3/9 Skip Traffic Stripe 6in White	0	0 /PM-Stripe-SKIP 3-9	2
X	dsgnsp	PMStripe6W(6-10)	Pavement Marking 6/10 Skip Traffic Stripe 6in White	0	0 /PM-Stripe-SKIP 6-10	2
X	dsgnsp	PMStripe6Y	Pavement Marking Traffic Stripe 6in Yellow	4	0 / Continuous	2
X	dsgnsp	PMStripe6Y(10-30)	Pavement Marking 10/30 Skip Traffic Stripe 6in Yellow	4	0 /PM-Stripe-SKIP 10-30	2
X	dsgnsp	PMStripe6Y(2-4)	Pavement Marking 2/4 Skip Traffic Stripe 6in Yellow	4	0 /PM-Stripe-SKIP 2-4	2

Critical	Rule	Level Name	Level Description	ByLevel Color	ByLevelStyle / Linetype	ByLevel Weight
X	dsgnsp	PMStripe6Y(6-10)	Pavement Marking 6/10 Skip Traffic Stripe 6in Yellow	4	0 /PM-Stripe-SKIP 6-10	2
X	dsgnsp	PMStripe8B	Pavement Marking Traffic Stripe 8in Black	3	0 / Continuous	3
X	dsgnsp	PMStripe8W	Pavement Marking Traffic Stripe 8in White	0	0 / Continuous	3
X	dsgnsp	PMStripe8W(3-9)	Pavement Marking 3/9 Skip Traffic Stripe 8in White	0	0 /PM-Stripe-SKIP 3-9	2
X	dsgnsp	PMStripe8Y	Pavement Marking Traffic Stripe 8in Yellow	4	0 / Continuous	3
X	dsgnsp	PMStripe9C(10-30)	Pavement Marking 10/30 Skip Traffic Stripe 9in Contrast	0	0 /PM-Stripe-SKIP 10-30	2
X	dsgnsp	PMStripeRumbleCL	Center Line Rumble Stripes (Use to Quantify Rumble Strips) (NonPlotting)	4	PM-Stripe-RumbleStripeLeft / PM-Stripe-RumbleStripe	2
X	dsgnsp	PMStripeRumbleWL	Rumble Stripes (6" White Thermoplastic Over Rumble Strips) (Left)	0	PM-Stripe-RumbleStripeLeft / PM-Stripe-RumbleStripe	2
X	dsgnsp	PMStripeRumbleWR	Rumble Stripes (6" White Thermoplastic Over Rumble Strips) (Right)	0	PM-Stripe-RumbleStripeRight / PM-Stripe-RumbleStripe	2
X	dsgnsp	PMStripeRumbleYL	Rumble Stripes (6" Yellow Thermoplastic Over Rumble Strips) (Left)	4	PM-Stripe-RumbleStripeLeft / PM-Stripe-RumbleStripe	2
X	dsgnsp	PMStripeRumbleYR	Rumble Stripes (6" Yellow Thermoplastic Over Rumble Strips) (Right)	4	PM-Stripe-RumbleStripeRight / PM-Stripe-RumbleStripe	2
X	dsgnsp	PMStripeVibeWL	Pavement Marking Auditory and Vibratory 6in White (Left)	0	PM-Stripe-VibratoryLeft /PM-Stripe-Vibratory	2
X	dsgnsp	PMStripeVibeWR	Pavement Marking Auditory and Vibratory 6in White (Right)	0	PM-Stripe-VibratoryRight /PM-Stripe-Vibratory	2
X	dsgnsp	PMStripeVibeYL	Pavement Marking Auditory and Vibratory 6in Yellow (Left)	4	PM-Stripe-VibratoryLeft /PM-Stripe-Vibratory	2
X	dsgnsp	PMStripeVibeYR	Pavement Marking Auditory and Vibratory 6in Yellow (Right)	4	PM-Stripe-VibratoryRight /PM-Stripe-Vibratory	2
X	dsgnsp	PMYieldL	Special Marking Area Yield Lines Large	0	PM-Stripe-YieldLarge	2
X	dsgnsp	PMYieldS	Special Marking Area Yield Lines Small	0	PM-Stripe-YieldSmall	2
	dsgnsp	PointLocator_ep	Point Locator Symbol (Existing)	4	0 / Continuous	0
	dsgnsp	ReferencePt_dp	Survey and Construction Reference Point Details and Elements	4	0 / Continuous	2
X	dsgnsp	ReflPaintWht	Reflective Paint - Island Nose (White)	0	0 / Continuous	3
X	dsgnsp	ReflPaintYel	Reflective Paint - Island Nose (Yellow)	4	0 / Continuous	3
X	dsgnsp	RPM_ep	Reflective Pavement Markers (Existing)	2	2 / DGN2	1
X	dsgnsp	RPM1	Raised Pavement Markers, White	0	0 / Continuous	2
X	dsgnsp	RPM2	Raised Pavement Markers, White - Red	3	0 / Continuous	2
X	dsgnsp	RPM3	Raised Pavement Markers, Yellow	4	0 / Continuous	2
X	dsgnsp	RPM4	Raised Pavement Markers, Yellow - Yellow	9	0 / Continuous	2
X	dsgnsp	RPM5	Raised Pavement Markers, Yellow - Red	6	0 / Continuous	2
X	dsgnsp	RPM6	Raised Pavement Markers, Blue	1	0 / Continuous	2
X	dsgnsp	SawCuts	Saw Cuts	3	3 / DGN3	0
	dsgnsp	Scale_dp	Bar Scale, Scale Label Elements	0	0 / Continuous	2
	dsgnsp	Scratch1_dp	Scratch Level for Temporary or Informational Items	4	0 / Continuous	0
	dsgnsp	Scratch2_dp	Scratch Level for Temporary or Informational Items	5	0 / Continuous	0
	dsgnsp	ScratchEle_dp	Scratch Level for Draft Elements, Temporary Elements, Etc. (DO NOT PLOT)	3	0 / Continuous	0
	dsgnsp	ScratchEle2_dp	Scratch Level for Draft Elements, Temporary Elements, Etc. (DO NOT PLOT)	4	0 / Continuous	0
	dsgnsp	SheetBorder_dp	Sheet Border	1	0 / Continuous	4
	dsgnsp	SheetLines_dp	Sheet Lines	1	0 / Continuous	2
	dsgnsp	SheetLinesMisc1_dp	Sheet Lines	1	0 / Continuous	0
	dsgnsp	SheetLinesMisc2_dp	Sheet Lines	2	0 / Continuous	2
	dsgnsp	SheetLinesMisc3_dp	Sheet Lines	3	0 / Continuous	2
	dsgnsp	SheetLinesMisc4_dp	Sheet Lines	4	0 / Continuous	2
X	dsgnsp	SignCantilever	Sign Symbol Cantilever	0	0 / Continuous	1
X	dsgnsp	SignCantilever_ep	Sign Symbol Cantilever (Existing)	0	2 / DGN2	0
	dsgnsp	SignDetail	Sign Details	0	0 / Continuous	2

Critical	Rule	Level Name	Level Description	ByLevel Color	ByLevelStyle / Linetype	ByLevel Weight
	dsgnsp	SignLettersAZ	Alphabet Cell Library Letter A-Z Numbers 0-9	0	0 / Continuous	0
	dsgnsp	SignMisc	Sign Symbols (Miscellaneous)	3	0 / Continuous	1
	dsgnsp	SignMisc_ep	Sign Symbols (Miscellaneous ) (Existing)	1	1 / DGN1	1
X	dsgnsp	SignPanel	Sign Panels - Regulatory	0	0 / Continuous	2
X	dsgnsp	SignPanel_ep	Sign Panel Elements (Existing)	0	2 / DGN2	1
X	dsgnsp	SignPanelBorder	Sign Panel Border on Sign Details	0	0 / Continuous	1
X	dsgnsp	SignPanelC	Sign Panels - Civil	1	0 / Continuous	2
X	dsgnsp	SignPanelDetRed	Sign Panel Details in Red	3	0 / Continuous	2
X	dsgnsp	SignPanelG	Sign Panels - Guide	2	0 / Continuous	2
X	dsgnsp	SignPanell	Sign Panels - Special Interest	9	0 / Continuous	2
X	dsgnsp	SignPanelT	Sign Panels - Construction	6	0 / Continuous	2
X	dsgnsp	SignPanelW	Sign Panels - Warning	4	0 / Continuous	2
	dsgnsp	SignSingle_ep	Sign (Single Support) (Existing)	3	2 / DGN2	0
X	dsgnsp	SignSpanwire	Span Wire Signing Assembly	2	0 / Continuous	1
X	dsgnsp	SignSpanwire_ep	Span Wire Signing Assembly (Existing)	2	2 / DGN2	1
X	dsgnsp	SignSpecial	Special Signs / Guide Signs	2	0 / Continuous	2
X	dsgnsp	SignSupport	Ground Mounted Sign Support Symbol (All Types)	1	0 / Continuous	1
	dsgnsp	SignSupport_ep	Trusses and Cantilevers for Overhead Signs (Existing)	0	3 / DGN3	1
X	dsgnsp	SignSymbol_px	Sign Structure and Foundation on Cross Sections	4	0 / Continuous	2
X	dsgnsp	SignTruss	Sign Symbol Truss	3	0 / Continuous	1
X	dsgnsp	SignTruss_ep	Sign Symbol Truss (Existing)	3	2 / DGN2	1
	dsgnsp	SpecialDetails	Special Details	6	0 / Continuous	1
	dsgnsp	StationTicL_dp	Station Tic Marks (Large) and Text	0	0 / Continuous	2
	dsgnsp	StationTicS_dp	Station Tic Marks (Small) and Text	0	0 / Continuous	2
	dsgnsp	SumBoxBorder_dp	Summary Boxes Borders	4	0 / Continuous	3
	dsgnsp	SumBoxLines_dp	Summary Boxes Lines and Miscellaneous Items	4	0 / Continuous	1
	dsgnsp	SumBoxLinesMin_dp	Summary Boxes Lines Minor Line and Miscellaneous Items	4	0 / Continuous	0
	dsgnsp	Tables_dp	Data Tables and All Autodesk Tables	0	0 / Continuous	1
	dsgnsp	TextBLStation	Text - B/L Station and Tics	0	0 / Continuous	2
	dsgnsp	TextConstEle	Text - Construction Element	0	0 / Continuous	1
	dsgnsp	TextCurveData	Text - Curve Data Note	0	0 / Continuous	2
	dsgnsp	TextDetails	Text - Detail Notes	4	0 / Continuous	2
	dsgnsp	TextDrainInvElev_ep	Text - Drainage Invert Elevation (Existing)	0	0 / Continuous	1
	dsgnsp	TextDrainLabel_ep	Text - Drainage (Existing)	0	0 / Continuous	1
	dsgnsp	TextElevLabel	Text - Elevation Labels	4	0 / Continuous	0
	dsgnsp	TextLabel	Text - Label	0	0 / Continuous	2
	dsgnsp	TextLandscape	Text - Landscape Labels	0	0 / Continuous	1
	dsgnsp	TextMajor	Text - Major	0	0 / Continuous	5
	dsgnsp	TextMinor	Text - Minor	0	0 / Continuous	0
	dsgnsp	TextMisc	Text - Miscellaneous	0	0 / Continuous	1
	dsgnsp	TextNotes	Text - Notes	4	0 / Continuous	1
	dsgnsp	TextProfLabel	Text - Profile, Horizontal and Vertical Axis Labels	0	0 / Continuous	2
	dsgnsp	TextProjLabel	Text - Begin and End Project Label with Leader Lines	1	0 / Continuous	2
	dsgnsp	TextPtLabel	Text - Point Labels	4	0 / Continuous	0
	dsgnsp	TextShtNo	Text - Sheet Number	0	0 / Continuous	2
	dsgnsp	TextSubUtilLabel_ep	Text - Subsurface Utilities (Existing)	0	0 / Continuous	1



Critical	Rule	Level Name	Level Description	ByLevel Color	ByLevelStyle / Linetype	ByLevel Weight
	dsgnsp	TextSurveyLabel	Text - Survey Labels	0	0 / Continuous	0
	dsgnsp	TextTables	Text - Key Sheet Indexes and Table Data	4	0 / Continuous	2
	dsgnsp	TextTitle	Text - Title	0	0 / Continuous	3
	dsgnsp	TextTopoLabel_ep	Text - Topography (Existing)	0	0 / Continuous	1
	dsgnsp	TextUtilLabel_ep	Text - Utilities (Existing)	0	0 / Continuous	1
	dsgnsp	TextXSElev	Text - Cross Section Elevations	2	0 / Continuous	1
	dsgnsp	Viewport	Viewport (For AutoCAD Use)	3	0 / Continuous	0
	dsgnsp	Xreference01_dp	Reference Files (For AutoCAD Use)	0	0 / Continuous	1
	dsgnsp	Xreference02_dp	Reference Files (For AutoCAD Use)	0	0 / Continuous	1
	dsgnsp	Xreference03_dp	Reference Files (For AutoCAD Use)	0	0 / Continuous	1
	dsgnsp	Xreference04_dp	Reference Files (For AutoCAD Use)	0	0 / Continuous	1
	dsgnsp	XSCell	GEOPAK Cross Section Cell/Block and Profile Cell/Block	8	0 / Continuous	1

## DTMRD - Digital Terrain (Proposed)

Critical	Rule	Level Name	Level Description	ByLevel Color	ByLevelStyle / Linetype	ByLevel Weight
	dtmrd	ActivePointCell_dp	Active Point Cell	4	0 / Continuous	10
	dtmrd	AdhocPoint_dp	Adhoc Points Placed by SheetInfo	0	4 / DGN4	0
	dtmrd	BreakLine_dp	Break Lines	0	0 / Continuous	1
	dtmrd	COGO_dp	COGO Information	3	0 / Continuous	1
	dtmrd	ConstLines	Construction Lines and References	1	0 / Continuous	0
	dtmrd	ConstLines_pm	Construction Lines	4	0 / Continuous	0
	dtmrd	ContoursMajor	Contour Lines Major	3	0 / Continuous	2
	dtmrd	ContoursMinor	Contour Lines Minor	4	0 / Continuous	2
	dtmrd	DimLines_dp	Dimension Lines, Corresponding Terminators, Equation Lines	0	0 / Continuous	1
	dtmrd	DTM	Digital Terrain Model, TIN Model Elements	1	0 / Continuous	2
	dtmrd	DTM_px	Digital Terrain Model on Cross Sections	1	0 / Continuous	0
	dtmrd	DTMSource	Digital Terrain Model, Source Feature	0	0 / Continuous	2
	dtmrd	DTMTriangles	Digital Terrain Model, Triangles	1	0 / Continuous	2
	dtmrd	DTMVertices	Digital Terrain Model, Triangle Vertices	2	0 / Continuous	1
X	dtmrd	FlowArrow	Digital Terrain Model, Triangle Flow Arrows	10	0 / Continuous	2
	dtmrd	GridMaj_dp	Grid Lines Major in Profile and Cross Section	3	0 / Continuous	1
	dtmrd	GridMin_dp	Grid Lines Minor in Profile and Cross Section	0	0 / Continuous	0
	dtmrd	GridMinSub_dp	Grid Lines Minor Sub on Cross Section Sheets	20	0 / Continuous	0
	dtmrd	ImageAttachment_dp	Image Attachments	0	0 / Continuous	0
	dtmrd	LeaderLine_dp	Leader Line and Terminator with Text	0	0 / Continuous	1
	dtmrd	Miscellaneous0	Undefined Proposed Item - Color Blue Weight 0	1	0 / Continuous	0
	dtmrd	Miscellaneous1	Undefined Proposed Item - Color Blue Weight 1	1	0 / Continuous	1
	dtmrd	Miscellaneous2	Undefined Proposed Item - Color Blue Weight 2	1	0 / Continuous	2
	dtmrd	Miscellaneous3	Undefined Proposed Item - Color Green Weight 0	2	0 / Continuous	0
	dtmrd	Miscellaneous4	Undefined Proposed Item - Color Green Weight 1	2	0 / Continuous	1
	dtmrd	Miscellaneous5	Undefined Proposed Item - Color Green Weight 2	2	0 / Continuous	2
	dtmrd	Miscellaneous6	Undefined Proposed Item - Color Red Weight 0	3	0 / Continuous	0
	dtmrd	Miscellaneous7	Undefined Proposed Item - Color Red Weight 1	3	0 / Continuous	1

Critical	Rule	Level Name	Level Description	Bylevel Color	ByLevelStyle / Linetype	Bylevel Weight
	dtmrd	Miscellaneous8	Undefined Proposed Item - Color Red Weight 2	3	0 / Continuous	2
	dtmrd	Miscellaneous9	Undefined Proposed Item - Color Red Weight 3	3	0 / Continuous	3
	dtmrd	NonPlottingEle_dp	Non-Plotting Items - Construction Elements, Type 66 Elements, Etc.	4	0 / Continuous	0
	dtmrd	PayItem_dp	Pay Item Number Label Elements	4	0 / Continuous	2
	dtmrd	ReferencePt_dp	Survey and Construction Reference Point Details and Elements	4	0 / Continuous	2
	dtmrd	Scratch1_dp	Scratch Level for Temporary or Informational Items	4	0 / Continuous	0
	dtmrd	Scratch2_dp	Scratch Level for Temporary or Informational Items	5	0 / Continuous	0
	dtmrd	ScratchEle_dp	Scratch Level for Draft Elements, Temporary Elements, Etc. (DO NOT PLOT)	3	0 / Continuous	0
	dtmrd	ScratchEle2_dp	Scratch Level for Draft Elements, Temporary Elements, Etc. (DO NOT PLOT)	4	0 / Continuous	0
	dtmrd	Tables_dp	Data Tables and All Autodesk Tables	0	0 / Continuous	1
	dtmrd	TextBLStation	Text - B/L Station and Tics	0	0 / Continuous	2
	dtmrd	TextConstEle	Text - Construction Element	0	0 / Continuous	1
	dtmrd	TextCurveData	Text - Curve Data Note	0	0 / Continuous	2
	dtmrd	TextDetails	Text - Detail Notes	4	0 / Continuous	2
	dtmrd	TextDrainInvElev_ep	Text - Drainage Invert Elevation (Existing)	0	0 / Continuous	1
	dtmrd	TextDrainLabel_ep	Text - Drainage (Existing)	0	0 / Continuous	1
	dtmrd	TextElevLabel	Text - Elevation Labels	4	0 / Continuous	0
	dtmrd	TextLabel	Text - Label	0	0 / Continuous	2
	dtmrd	TextLandscape	Text - Landscape Labels	0	0 / Continuous	1
	dtmrd	TextMajor	Text - Major	0	0 / Continuous	5
	dtmrd	TextMinor	Text - Minor	0	0 / Continuous	0
	dtmrd	TextMisc	Text - Miscellaneous	0	0 / Continuous	1
	dtmrd	TextNotes	Text - Notes	4	0 / Continuous	1
	dtmrd	TextProfLabel	Text - Profile, Horizontal and Vertical Axis Labels	0	0 / Continuous	2
	dtmrd	TextProjLabel	Text - Begin and End Project Label with Leader Lines	1	0 / Continuous	2
	dtmrd	TextPtLabel	Text - Point Labels	4	0 / Continuous	0
	dtmrd	TextShtNo	Text - Sheet Number	0	0 / Continuous	2
	dtmrd	TextSubUtilLabel_ep	Text - Subsurface Utilities (Existing)	0	0 / Continuous	1
	dtmrd	TextSurveyLabel	Text - Survey Labels	0	0 / Continuous	0
	dtmrd	TextTables	Text - Key Sheet Indexes and Table Data	4	0 / Continuous	2
	dtmrd	TextTitle	Text - Title	0	0 / Continuous	3
	dtmrd	TextTopoLabel_ep	Text - Topography (Existing)	0	0 / Continuous	1
	dtmrd	TextUtilLabel_ep	Text - Utilities (Existing)	0	0 / Continuous	1
	dtmrd	TextXSElev	Text - Cross Section Elevations	2	0 / Continuous	1
	dtmrd	Viewport	Viewport (For AutoCAD Use)	3	0 / Continuous	0
	dtmrd	VoidArea_dx	Void Area on Cross Sections	1	0 / Continuous	0
	dtmrd	Voids_dp	Voids	11	3 / DGN3	1
	dtmrd	Xreference01_dp	Reference Files (For AutoCAD Use)	0	0 / Continuous	1
	dtmrd	Xreference02_dp	Reference Files (For AutoCAD Use)	0	0 / Continuous	1
	dtmrd	Xreference03_dp	Reference Files (For AutoCAD Use)	0	0 / Continuous	1
	dtmrd	Xreference04_dp	Reference Files (For AutoCAD Use)	0	0 / Continuous	1
	dtmrd	XSCell	GEOPAK Cross Section Cell/Block and Profile Cell/Block	8	0 / Continuous	1



## GDTMRD - Digital Terrain (Existing)

Critical	Rule	Level Name	Level Description	ByLevel Color	ByLevelStyle / Linetype	Bylevel Weight
	gdtmrd	ContoursMajor_ep	Contour Lines Major (Existing)	3	1 / DGN1	1
	gdtmrd	ContoursMinor_ep	Contour Lines Minor (Existing)	4	1 / DGN1	1
	gdtmrd	DTM_ep	Digital Terrain Model, TIN Model Elements (Existing)	2	0 / Continuous	1
	gdtmrd	DTM_ex	Digital Terrain Model on Cross Sections (Existing)	2	2 / DGN2	1
	gdtmrd	DTMSource_ep	Digital Terrain, Source Feature (Existing)	0	1 / DGN1	1
	gdtmrd	DTMTriangles_ep	DTM Triangles (Existing)	2	0 / Continuous	1
	gdtmrd	DTMVertices_ep	Digital Terrain Model, Triangle Vertices (Existing)	0	0 / Continuous	1
X	gdtmrd	FlowArrow_ep	Digital Terrain Model, Triangle Flow Arrows (Existing)	10	0 / Continuous	1

## GEOTECH - Geotechnical

Critical	Rule	Level Name	Level Description	ByLevel Color	ByLevelStyle / Linetype	Bylevel Weight
	geotech	ActivePointCell_dp	Active Point Cell	4	0 / Continuous	10
	geotech	AdhocPoint_dp	Adhoc Points Placed by SheetInfo	0	4 / DGN4	0
	geotech	COGO_dp	COGO Information	3	0 / Continuous	1
	geotech	ConstLines	Construction Lines and References	1	0 / Continuous	0
	geotech	ConstLines_pm	Construction Lines	4	0 / Continuous	0
	geotech	Dimension	Dimension Lines (Structures)	0	0 / Continuous	0
	geotech	DimLines_dp	Dimension Lines, Corresponding Terminators, Equation Lines	0	0 / Continuous	1
X	geotech	EaseLicLine	Easement License Agreement Line	5	6 / DGN6	0
	geotech	GeotechFillPatt1	Geotechnical Fill Pattern - (Earth, Wood, Muck, Concrete, Rock, Riprap) as Defined in Project	3	0 / Continuous	0
	geotech	GeotechFillPatt2	Geotechnical Fill Pattern - Clay, Sand	0	1 / DGN1	0
	geotech	GeotechFillPatt3	Geotechnical Fill Pattern - Shell	3	1 / DGN1	0
	geotech	GeotechFillPatt4	Geotechnical Fill Pattern - Sand	4	0 / Continuous	0
	geotech	GeotechFillPatt5	Geotechnical Fill Pattern - Coquina	1	0 / Continuous	1
	geotech	GeotechFillPatt6	Geotechnical Fill Pattern - Limestone	2	0 / Continuous	0
	geotech	GeotechFillPatt7	Geotechnical Fill Pattern - Gravel	6	0 / Continuous	0
	geotech	GeotechFillPatt8	Geotechnical Fill Pattern - Silt	0	0 / Continuous	1
	geotech	GeotechMisc	Geotechnical Elements (Miscellaneous)	0	0 / Continuous	1
	geotech	GridMaj_dp	Grid Lines Major in Profile and Cross Section	3	0 / Continuous	1
	geotech	GridMin_dp	Grid Lines Minor in Profile and Cross Section	0	0 / Continuous	0
	geotech	GridMinG_dp	Grid Lines Minor Sub 2 on Cross Section Sheets	20	0 / Continuous	0
	geotech	GridMinSub_dp	Grid Lines Minor Sub on Cross Section Sheets	20	0 / Continuous	0
	geotech	ImageAttachment_dp	Image Attachments	0	0 / Continuous	0
	geotech	LeaderLine_dp	Leader Line and Terminator with Text	0	0 / Continuous	1
	geotech	Logo_dp	Consultant Engineer of Record Logo	0	0 / Continuous	1
	geotech	Miscellaneous0	Undefined Proposed Item - Color Blue Weight 0	1	0 / Continuous	0
	geotech	Miscellaneous1	Undefined Proposed Item - Color Blue Weight 1	1	0 / Continuous	1
	geotech	Miscellaneous2	Undefined Proposed Item - Color Blue Weight 2	1	0 / Continuous	2
	geotech	Miscellaneous3	Undefined Proposed Item - Color Green Weight 0	2	0 / Continuous	0
	geotech	Miscellaneous4	Undefined Proposed Item - Color Green Weight 1	2	0 / Continuous	1
	geotech	Miscellaneous5	Undefined Proposed Item - Color Green Weight 2	2	0 / Continuous	2

Critical	Rule	Level Name	Level Description	ByLevel Color	ByLevelStyle / Linetype	ByLevel Weight
	geotech	Miscellaneous6	Undefined Proposed Item - Color Red Weight 0	3	0 / Continuous	0
	geotech	Miscellaneous7	Undefined Proposed Item - Color Red Weight 1	3	0 / Continuous	1
	geotech	Miscellaneous8	Undefined Proposed Item - Color Red Weight 2	3	0 / Continuous	2
	geotech	Miscellaneous9	Undefined Proposed Item - Color Red Weight 3	3	0 / Continuous	3
	geotech	NonPlottingEle_dp	Non-Plotting Items - Construction Elements, Type 66 Elements, Etc.	4	0 / Continuous	0
	geotech	NorthArw_dp	North Arrows	0	0 / Continuous	2
	geotech	Patterning	All; Any Patterning	3	0 / Continuous	1
	geotech	Patternlines_ep	Cross Section Chain (Existing)	2	1 / DGN1	0
	geotech	PatternLines1_dp	Pattern Lines on Cross Sections and All Autodesk (Civil 3D) Tables	3	0 / Continuous	2
	geotech	PatternLines2_dp	Pattern Lines on Cross Sections Alternate for Side Streets, CriticalCross Sections or Drainage Structures	4	0 / Continuous	2
	geotech	PatternLines3_dp	Pattern Lines on Cross Sections Alternate for Side Streets, CriticalCross Sections or Drainage Structures	5	0 / Continuous	2
	geotech	PayItem_dp	Pay Item Number Label Elements	4	0 / Continuous	2
X	geotech	PlotBorder_dp	Plot Border	3	0 / Continuous	0
	geotech	PointLocator_ep	Point Locator Symbol (Existing)	4	0 / Continuous	0
	geotech	ReferencePt_dp	Survey and Construction Reference Point Details and Elements	4	0 / Continuous	2
	geotech	Scale_dp	Bar Scale, Scale Label Elements	0	0 / Continuous	2
	geotech	Scratch1_dp	Scratch Level for Temporary or Informational Items	4	0 / Continuous	0
	geotech	Scratch2_dp	Scratch Level for Temporary or Informational Items	5	0 / Continuous	0
	geotech	ScratchEle_dp	Scratch Level for Draft Elements, Temporary Elements, Etc. (DO NOT PLOT)	3	0 / Continuous	0
	geotech	ScratchEle2_dp	Scratch Level for Draft Elements, Temporary Elements, Etc. (DO NOT PLOT)	4	0 / Continuous	0
	geotech	SheetBorder_dp	Sheet Border	1	0 / Continuous	4
	geotech	SheetLines_dp	Sheet Lines	1	0 / Continuous	2
	geotech	SheetLinesMisc1_dp	Sheet Lines	1	0 / Continuous	0
	geotech	SheetLinesMisc2_dp	Sheet Lines	2	0 / Continuous	2
	geotech	SheetLinesMisc3_dp	Sheet Lines	3	0 / Continuous	2
	geotech	SheetLinesMisc4_dp	Sheet Lines	4	0 / Continuous	2
X	geotech	SoilBoring	Soil Boring Elements	5	0 / Continuous	1
	geotech	SoilBoringLoc_dp	Soil Boring Location Symbol	4	0 / Continuous	2
	geotech	SoilBoxes_dp	Soil Boxes	4	0 / Continuous	1
X	geotech	SoilBoxes_px	Soil Boxes and Borings on Cross Sections	4	0 / Continuous	1
	geotech	SumBoxBorder_dp	Summary Boxes Borders	4	0 / Continuous	3
	geotech	SumBoxLines_dp	Summary Boxes Lines and Miscellaneous Items	4	0 / Continuous	1
	geotech	SumBoxLinesMin_dp	Summary Boxes Lines Minor Line and Miscellaneous Items	4	0 / Continuous	0
	geotech	Tables_dp	Data Tables and All Autodesk Tables	0	0 / Continuous	1
	geotech	TextAlert	Text - Alert Label to Highlight a Problem	3	0 / Continuous	2
	geotech	TextBLStation	Text - B/L Station and Tics	0	0 / Continuous	2
	geotech	TextConstEle	Text - Construction Element	0	0 / Continuous	1
	geotech	TextCurveData	Text - Curve Data Note	0	0 / Continuous	2
	geotech	TextDetails	Text - Detail Notes	4	0 / Continuous	2
	geotech	TextDrainInvElev_ep	Text - Drainage Invert Elevation (Existing)	0	0 / Continuous	1
	geotech	TextDrainLabel_ep	Text - Drainage (Existing)	0	0 / Continuous	1
	geotech	TextElevLabel	Text - Elevation Labels	4	0 / Continuous	0
	geotech	TextGeotech	Text - Soil Borings and Labels	0	0 / Continuous	2
	geotech	TextLabel	Text - Label	0	0 / Continuous	2
	geotech	TextLandscape	Text - Landscape Labels	0	0 / Continuous	1
	geotech	TextMajor	Text - Major	0	0 / Continuous	5

Critical	Rule	Level Name	Level Description	ByLevel Color	ByLevelStyle / Linetype	ByLevel Weight
	geotech	TextMinor	Text - Minor	0	0 / Continuous	0
	geotech	TextMisc	Text - Miscellaneous	0	0 / Continuous	1
	geotech	TextNotes	Text - Notes	4	0 / Continuous	1
	geotech	TextProfLabel	Text - Profile, Horizontal and Vertical Axis Labels	0	0 / Continuous	2
	geotech	TextProjLabel	Text - Begin and End Project Label with Leader Lines	1	0 / Continuous	2
	geotech	TextPtLabel	Text - Point Labels	4	0 / Continuous	0
	geotech	TextShtNo	Text - Sheet Number	0	0 / Continuous	2
	geotech	TextSubUtilLabel_ep	Text - Subsurface Utilities (Existing)	0	0 / Continuous	1
	geotech	TextStructures	Text - Structures	0	0 / Continuous	0
	geotech	TextSurveyLabel	Text - Survey Labels	0	0 / Continuous	0
	geotech	TextTables	Text - Key Sheet Indexes and Table Data	4	0 / Continuous	2
	geotech	TextTitle	Text - Title	0	0 / Continuous	3
	geotech	TextTopoLabel_ep	Text - Topography (Existing)	0	0 / Continuous	1
	geotech	TextUtilLabel_ep	Text - Utilities (Existing)	0	0 / Continuous	1
	geotech	TextXSElev	Text - Cross Section Elevations	2	0 / Continuous	1
	geotech	Viewport	Viewport (For AutoCAD Use)	3	0 / Continuous	0
	geotech	Xreference01_dp	Reference Files (For AutoCAD Use)	0	0 / Continuous	1
	geotech	Xreference02_dp	Reference Files (For AutoCAD Use)	0	0 / Continuous	1
	geotech	Xreference03_dp	Reference Files (For AutoCAD Use)	0	0 / Continuous	1
	geotech	Xreference04_dp	Reference Files (For AutoCAD Use)	0	0 / Continuous	1
	geotech	XSCell	GEOPAK Cross Section Cell/Block and Profile Cell/Block	8	0 / Continuous	1

## GSWKSP - GuidSIGN

Critical	Rule	Level Name	Level Description	ByLevel Color	ByLevelStyle / Linetype	ByLevel Weight
	gswksp	ActivePointCell_dp	Active Point Cell	4	0 / Continuous	10
	gswksp	AdhocPoint_dp	Adhoc Points Placed by SheetInfo	0	4 / DGN4	0
	gswksp	COGO_dp	COGO Information	3	0 / Continuous	1
	gswksp	ConstLines	Construction Lines and References	1	0 / Continuous	0
	gswksp	ConstLines_pm	Construction Lines	4	0 / Continuous	0
	gswksp	DimLines_dp	Dimension Lines, Corresponding Terminators, Equation Lines	0	0 / Continuous	1
X	gswksp	EaseLicLine	Easement License Agreement Line	5	6 / DGN6	0
	gswksp	GridMaj_dp	Grid Lines Major in Profile and Cross Section	3	0 / Continuous	1
	gswksp	GridMin_dp	Grid Lines Minor in Profile and Cross Section	0	0 / Continuous	0
	gswksp	GridMinSub_dp	Grid Lines Minor Sub on Cross Section Sheets	20	0 / Continuous	0
	gswksp	GSBWFill	GuidSign Black and White Fill Level for GuidSign Cells	0	0 / Continuous	1
	gswksp	GSColorFill	GuidSign Color Fill Level for GuidSign Cells	2	0 / Continuous	1
	gswksp	GSDims	GuidSign Dimensions	0	0 / Continuous	1
	gswksp	GSOuline	GuidSign Outline Level for GuidSign Cells	0	0 / Continuous	2
	gswksp	GSSign	GuidSign Panel and Tag	7	0 / Continuous	0
	gswksp	ImageAttachment_dp	Image Attachments	0	0 / Continuous	0
	gswksp	KeyShtMisc	Key Sheet Items (Miscellaneous)	0	0 / Continuous	2
	gswksp	LeaderLine_dp	Leader Line and Terminator with Text	0	0 / Continuous	1
	gswksp	Logo_dp	Consultant Engineer of Record Logo	0	0 / Continuous	1
	gswksp	Miscellaneous0	Undefined Proposed Item - Color Blue Weight 0	1	0 / Continuous	0

Critical	Rule	Level Name	Level Description	ByLevel Color	ByLevelStyle / Linetype	ByLevel Weight
	gswksp	Miscellaneous1	Undefined Proposed Item - Color Blue Weight 1	1	0 / Continuous	1
	gswksp	Miscellaneous2	Undefined Proposed Item - Color Blue Weight 2	1	0 / Continuous	2
	gswksp	Miscellaneous3	Undefined Proposed Item - Color Green Weight 0	2	0 / Continuous	0
	gswksp	Miscellaneous4	Undefined Proposed Item - Color Green Weight 1	2	0 / Continuous	1
	gswksp	Miscellaneous5	Undefined Proposed Item - Color Green Weight 2	2	0 / Continuous	2
	gswksp	Miscellaneous6	Undefined Proposed Item - Color Red Weight 0	3	0 / Continuous	0
	gswksp	Miscellaneous7	Undefined Proposed Item - Color Red Weight 1	3	0 / Continuous	1
	gswksp	Miscellaneous8	Undefined Proposed Item - Color Red Weight 2	3	0 / Continuous	2
	gswksp	Miscellaneous9	Undefined Proposed Item - Color Red Weight 3	3	0 / Continuous	3
	gswksp	NonPlottingEle_dp	Non-Plotting Items - Construction Elements, Type 66 Elements, Etc.	4	0 / Continuous	0
	gswksp	NorthArw_dp	North Arrows	0	0 / Continuous	2
X	gswksp	ObjectMarker	Object and Reflective Markers	3	0 / Continuous	1
X	gswksp	OverheadSign	Overhead Sign Panels	0	0 / Continuous	2
X	gswksp	OverheadSign_ep	Overhead Sign Panels (Existing)	0	3 / DGN3	1
X	gswksp	OverheadStr	Mast Arm, Truss Assemblies, Signal Arms and Supports	0	0 / Continuous	2
X	gswksp	OverheadStr_ep	Mast Arm, Truss Assemblies, Signal Arms and Supports (Existing)	0	3 / DGN3	1
	gswksp	PayItem_dp	Pay Item Number Label Elements	4	0 / Continuous	2
X	gswksp	PlotBorder_dp	Plot Border	3	0 / Continuous	0
	gswksp	PointLocator_ep	Point Locator Symbol (Existing)	4	0 / Continuous	0
	gswksp	ReferencePt_dp	Survey and Construction Reference Point Details and Elements	4	0 / Continuous	2
	gswksp	Scale_dp	Bar Scale, Scale Label Elements	0	0 / Continuous	2
	gswksp	Scratch1_dp	Scratch Level for Temporary or Informational Items	4	0 / Continuous	0
	gswksp	Scratch2_dp	Scratch Level for Temporary or Informational Items	5	0 / Continuous	0
	gswksp	ScratchEle_dp	Scratch Level for Draft Elements, Temporary Elements, Etc. (DO NOT PLOT)	3	0 / Continuous	0
	gswksp	ScratchEle2_dp	Scratch Level for Draft Elements, Temporary Elements, Etc. (DO NOT PLOT)	4	0 / Continuous	0
	gswksp	SheetLines_dp	Sheet Lines	1	0 / Continuous	2
	gswksp	SheetLinesMisc1_dp	Sheet Lines	1	0 / Continuous	0
	gswksp	SheetLinesMisc2_dp	Sheet Lines	2	0 / Continuous	2
	gswksp	SheetLinesMisc3_dp	Sheet Lines	3	0 / Continuous	2
	gswksp	SheetLinesMisc4_dp	Sheet Lines	4	0 / Continuous	2
X	gswksp	SignCantilever	Sign Symbol Cantilever	0	0 / Continuous	1
X	gswksp	SignCantilever_ep	Sign Symbol Cantilever (Existing)	0	2 / DGN2	0
	gswksp	SignDetail	Sign Details	0	0 / Continuous	2
	gswksp	SignLettersAZ	Alphabet Cell Library Letter A-Z Numbers 0-9	0	0 / Continuous	0
	gswksp	SignMisc	Sign Symbols (Miscellaneous)	3	0 / Continuous	1
	gswksp	SignMisc_ep	Sign Symbols (Miscellaneous) (Existing)	1	1 / DGN1	1
X	gswksp	SignPanel	Sign Panels - Regulatory	0	0 / Continuous	2
X	gswksp	SignPanel_ep	Sign Panel Elements (Existing)	0	2 / DGN2	1
X	gswksp	SignPanelBorder	Sign Panel Border on Sign Details	0	0 / Continuous	1
X	gswksp	SignPanelC	Sign Panels - Civil	1	0 / Continuous	2
X	gswksp	SignPanelDetRed	Sign Panel Details in Red	3	0 / Continuous	2
X	gswksp	SignPanelG	Sign Panels - Guide	2	0 / Continuous	2
X	gswksp	SignPanell	Sign Panels - Special Interest	9	0 / Continuous	2
X	gswksp	SignPanelT	Sign Panels - Construction	6	0 / Continuous	2
X	gswksp	SignPanelW	Sign Panels - Warning	4	0 / Continuous	2
X	gswksp	SignSpanwire	Span Wire Signing Assembly	2	0 / Continuous	1
X	gswksp	SignSpanwire_ep	Span Wire Signing Assembly (Existing)	2	2 / DGN2	1
X	gswksp	SignSpecial	Special Signs / Guide Signs	2	0 / Continuous	2

Critical	Rule	Level Name	Level Description	ByLevel Color	ByLevelStyle / Linetype	ByLevel Weight
X	gswksp	SignSupport	Ground Mounted Sign Support Symbol (All Types)	1	0 / Continuous	1
X	gswksp	SignSymbol_px	Sign Structure and Foundation on Cross Sections	4	0 / Continuous	2
X	gswksp	SignTruss	Sign Symbol Truss	3	0 / Continuous	1
X	gswksp	SignTruss_ep	Sign Symbol Truss (Existing)	3	2 / DGN2	1
	gswksp	SumBoxBorder_dp	Summary Boxes Borders	4	0 / Continuous	3
	gswksp	SumBoxLines_dp	Summary Boxes Lines and Miscellaneous Items	4	0 / Continuous	1
	gswksp	SumBoxLinesMin_dp	Summary Boxes Lines Minor Line and Miscellaneous Items	4	0 / Continuous	0
	gswksp	Tables_dp	Data Tables and All Autodesk Tables	0	0 / Continuous	1
	gswksp	TextBLStation	Text - B/L Station and Tics	0	0 / Continuous	2
	gswksp	TextConstEle	Text - Construction Element	0	0 / Continuous	1
	gswksp	TextCurveData	Text - Curve Data Note	0	0 / Continuous	2
	gswksp	TextDetails	Text - Detail Notes	4	0 / Continuous	2
	gswksp	TextDrainInvElev_ep	Text - Drainage Invert Elevation (Existing)	0	0 / Continuous	1
	gswksp	TextDrainLabel_ep	Text - Drainage (Existing)	0	0 / Continuous	1
	gswksp	TextElevLabel	Text - Elevation Labels	4	0 / Continuous	0
	gswksp	TextLabel	Text - Label	0	0 / Continuous	2
	gswksp	TextLandscape	Text - Landscape Labels	0	0 / Continuous	1
	gswksp	TextMajor	Text - Major	0	0 / Continuous	5
	gswksp	TextMinor	Text - Minor	0	0 / Continuous	0
	gswksp	TextMisc	Text - Miscellaneous	0	0 / Continuous	1
	gswksp	TextNotes	Text - Notes	4	0 / Continuous	1
	gswksp	TextProfLabel	Text - Profile, Horizontal and Vertical Axis Labels	0	0 / Continuous	2
	gswksp	TextProjLabel	Text - Begin and End Project Label with Leader Lines	1	0 / Continuous	2
	gswksp	TextPtLabel	Text - Point Labels	4	0 / Continuous	0
	gswksp	TextShtNo	Text - Sheet Number	0	0 / Continuous	2
	gswksp	TextSubUtilLabel_ep	Text - Subsurface Utilities (Existing)	0	0 / Continuous	1
	gswksp	TextSurveyLabel	Text - Survey Labels	0	0 / Continuous	0
	gswksp	TextTables	Text - Key Sheet Indexes and Table Data	4	0 / Continuous	2
	gswksp	TextTitle	Text - Title	0	0 / Continuous	3
	gswksp	TextSubUtilLabel_ep	Text - Subsurface Utilities (Existing)	0	0 / Continuous	1
	gswksp	TextTopoLabel_ep	Text - Topography (Existing)	0	0 / Continuous	1
	gswksp	TextXSElev	Text - Cross Section Elevations	2	0 / Continuous	1
	gswksp	Viewport	Viewport (For AutoCAD Use)	3	0 / Continuous	0
	gswksp	Xreference01_dp	Reference Files (For AutoCAD Use)	0	0 / Continuous	1
	gswksp	Xreference02_dp	Reference Files (For AutoCAD Use)	0	0 / Continuous	1
	gswksp	Xreference03_dp	Reference Files (For AutoCAD Use)	0	0 / Continuous	1
	gswksp	Xreference04_dp	Reference Files (For AutoCAD Use)	0	0 / Continuous	1
	gswksp	XSCell	GEOPAK Cross Section Cell/Block and Profile Cell/Block	8	0 / Continuous	1

## IRRGLD - Irrigation

Critical	Rule	Level Name	Level Description	ByLevel Color	ByLevelStyle / Linetype	ByLevel Weight
	irrgld	ActivePointCell_dp	Active Point Cell	4	0 / Continuous	10
	irrgld	AdhocPoint_dp	Adhoc Points Placed by SheetInfo	0	4/ DGN4	0
	irrgld	COGO_dp	COGO Information	3	0 / Continuous	1
	irrgld	ConstLines	Construction Lines and References	1	0 / Continuous	0
	irrgld	ConstLines_pm	Construction Lines	4	0 / Continuous	0
	irrgld	DimLines_dp	Dimension Lines, Corresponding Terminators, Equation Lines	0	0 / Continuous	1
	irrgld	DripSystem	Irrigation Drip System	1	0 / Continuous	2
X	irrgld	EaseLicLine	Easement License Agreement Line	5	6 / DGN6	0
	irrgld	ImageAttachment_dp	Image Attachments	0	0 / Continuous	0
X	irrgld	IrrigationHeads	Irrigation Heads (All Types)	5	0 / Continuous	2
X	irrgld	IrrigationLateral	Irrigation Lateral Line	7	0 / Continuous	1
X	irrgld	IrrigationLateralNP	Irrigation Lateral (Reclaimed)	12	0 / Continuous	1
X	irrgld	IrrigationMain	Irrigation Main Line	1	3 / DGN3	3
X	irrgld	IrrigationMainNP	Irrigation Main Line (Reclaimed)	8	3 / DGN3	3
	irrgld	IrrigationMisc	Irrigation Items (Miscellaneous)	0	0 / Continuous	2
X	irrgld	IrrigationMiscNP	Irrigation Equipment (Reclaimed)	8	0 / Continuous	1
X	irrgld	IrrigationSleeve	Irrigation Sleeve	6	5 / DGN5	1
	irrgld	IrrigationSprayPat	Irrigation Head Spray Pattern	1	1 / DGN1	1
	irrgld	LeaderLine_dp	Leader Line and Terminator with Text	0	0 / Continuous	1
X	irrgld	MechanicalAccs	Mechanical Irrigation Items (Valves, Meters, Pipe, Clocks, Back Flow)	3	0 / Continuous	1
	irrgld	Miscellaneous0	Undefined Proposed Item - Color Blue Weight 0	1	0 / Continuous	0
	irrgld	Miscellaneous1	Undefined Proposed Item - Color Blue Weight 1	1	0 / Continuous	1
	irrgld	Miscellaneous2	Undefined Proposed Item - Color Blue Weight 2	1	0 / Continuous	2
	irrgld	Miscellaneous3	Undefined Proposed Item - Color Green Weight 0	2	0 / Continuous	0
	irrgld	Miscellaneous4	Undefined Proposed Item - Color Green Weight 1	2	0 / Continuous	1
	irrgld	Miscellaneous5	Undefined Proposed Item - Color Green Weight 2	2	0 / Continuous	2
	irrgld	Miscellaneous6	Undefined Proposed Item - Color Red Weight 0	3	0 / Continuous	0
	irrgld	Miscellaneous7	Undefined Proposed Item - Color Red Weight 1	3	0 / Continuous	1
	irrgld	Miscellaneous8	Undefined Proposed Item - Color Red Weight 2	3	0 / Continuous	2
	irrgld	Miscellaneous9	Undefined Proposed Item - Color Red Weight 3	3	0 / Continuous	3
	irrgld	NonPlottingEle_dp	Non-Plotting Items - Construction Elements, Type 66 Elements, Etc.	4	0 / Continuous	0
	irrgld	PayItem_dp	Pay Item Number Label Elements	4	0 / Continuous	2
	irrgld	PointLocator_ep	Point Locator Symbol (Existing)	4	0 / Continuous	0
	irrgld	ReferencePt_dp	Survey and Construction Reference Point Details and Elements	4	0 / Continuous	2
	irrgld	Scratch1_dp	Scratch Level for Temporary or Informational Items	4	0 / Continuous	0
	irrgld	Scratch2_dp	Scratch Level for Temporary or Informational Items	5	0 / Continuous	0
	irrgld	ScratchEle_dp	Scratch Level for Draft Elements, Temporary Elements, Etc. (DO NOT PLOT)	3	0 / Continuous	0
	irrgld	ScratchEle2_dp	Scratch Level for Draft Elements, Temporary Elements, Etc. (DO NOT PLOT)	4	0 / Continuous	0
	irrgld	Tables_dp	Data Tables and All Autodesk Tables	0	0 / Continuous	1
	irrgld	TextBLStation	Text - B/L Station and Tics	0	0 / Continuous	2
	irrgld	TextConstEle	Text - Construction Element	0	0 / Continuous	1
	irrgld	TextCurveData	Text - Curve Data Note	0	0 / Continuous	2
	irrgld	TextDetails	Text - Detail Notes	4	0 / Continuous	2
	irrgld	TextDrainInvElev_ep	Text - Drainage Invert Elevation (Existing)	0	0 / Continuous	1

Critical	Rule	Level Name	Level Description	ByLevel Color	ByLevelStyle / Linetype	ByLevel Weight
	irrgld	TextDrainLabel_ep	Text - Drainage (Existing)	0	0 / Continuous	1
	irrgld	TextElevLabel	Text - Elevation Labels	4	0 / Continuous	0
	irrgld	TextLabel	Text - Label	0	0 / Continuous	2
	irrgld	TextLandscape	Text - Landscape Labels	0	0 / Continuous	1
	irrgld	TextMajor	Text - Major	0	0 / Continuous	5
	irrgld	TextMinor	Text - Minor	0	0 / Continuous	0
	irrgld	TextMisc	Text - Miscellaneous	0	0 / Continuous	1
	irrgld	TextNotes	Text - Notes	4	0 / Continuous	1
	irrgld	TextProfLabel	Text - Profile, Horizontal and Vertical Axis Labels	0	0 / Continuous	2
	irrgld	TextProjLabel	Text - Begin and End Project Label with Leader Lines	1	0 / Continuous	2
	irrgld	TextPtLabel	Text - Point Labels	4	0 / Continuous	0
	irrgld	TextShtNo	Text - Sheet Number	0	0 / Continuous	2
	irrgld	TextSubUtilLabel_ep	Text - Subsurface Utilities (Existing)	0	0 / Continuous	1
	irrgld	TextSurveyLabel	Text - Survey Labels	0	0 / Continuous	0
	irrgld	TextTables	Text - Key Sheet Indexes and Table Data	4	0 / Continuous	2
	irrgld	TextTitle	Text - Title	0	0 / Continuous	3
	irrgld	TextTopoLabel_ep	Text - Topography (Existing)	0	0 / Continuous	1
	irrgld	TextUtilLabel_ep	Text - Utilities (Existing)	0	0 / Continuous	1
	irrgld	TextXSElev	Text - Cross Section Elevations	2	0 / Continuous	1
	irrgld	Viewport	Viewport (For AutoCAD Use)	3	0 / Continuous	0
	irrgld	Xreference01_dp	Reference Files (For AutoCAD Use)	0	0 / Continuous	1
	irrgld	Xreference02_dp	Reference Files (For AutoCAD Use)	0	0 / Continuous	1
	irrgld	Xreference03_dp	Reference Files (For AutoCAD Use)	0	0 / Continuous	1
	irrgld	Xreference04_dp	Reference Files (For AutoCAD Use)	0	0 / Continuous	1
	irrgld	XSCell	GEOPAK Cross Section Cell/Block and Profile Cell/Block	8	0 / Continuous	1

## ITSSP - Intelligent Transportation System

Critical	Rule	Level Name	Level Description	ByLevel Color	ByLevelStyle / Linetype	ByLevel Weight
	itssp	ActivePointCell_dp	Active Point Cell	4	0 / Continuous	10
	itssp	AdhocPoint_dp	Adhoc Points Placed by SheetInfo	0	4 / DGN4	0
	itssp	BaselineSurvey	Baseline Survey	0	0 / Continuous	2
X	itssp	CCTV	CC TV Camera and Accessories	4	0 / Continuous	1
X	itssp	CCTV_ep	CC TV Camera and Accessories (Existing)	4	0 / Continuous	0
X	itssp	CCTVAer	CC TV Cable - Aerial	6	UT-OverheadCable-Proposed	1
X	itssp	CCTVBur	CC TV Cable - Buried	5	UT-BuriedCable-Proposed	1
	itssp	CCTVMisc	CC TV Service Box and Miscellaneous	6	0 / Continuous	0
	itssp	CLConst_dp	Center Line of Construction	0	0 / Continuous	2
	itssp	Cloud_dp	Construction Cloud	7	0 / Continuous	2
	itssp	COGO_dp	COGO Information	3	0 / Continuous	1
X	itssp	ConduitAG	Conduit (Above Ground)	4	SG-ConduitAG-Proposed	1
X	itssp	ConduitBM	Conduit – Bridge Mount	5	SG-ConduitBM-Proposed	1
X	itssp	ConduitDB	Conduit – Directional Bore	2	SG-ConduitDB-Proposed	1
X	itssp	ConduitJB	Conduit – Jack & Bore Under Rail	3	SG-ConduitJB-Proposed	1



Critical	Rule	Level Name	Level Description	ByLevel Color	ByLevelStyle / Linetype	ByLevel Weight
X	itssp	ConduitOT	Conduit – Open Trench	1	SG-ConduitOT-Proposed	1
	itssp	ConstArea_dp	Construction Area Crosshatch	0	0 / Continuous	1
	itssp	ConstLimits	Construction Limits	3	RW-LimitsofConst	2
	itssp	ConstLines	Construction Lines and References	1	0 / Continuous	0
	itssp	ConstLines_pm	Construction Lines	4	0 / Continuous	0
X	itssp	Controller	Controller and Accessories	0	0 / Continuous	2
X	itssp	Controller_ep	Controller and Accessories (Existing)	0	2 / DGN2	1
X	itssp	ControllerAccess	Controller Accessories	0	0 / Continuous	1
X	itssp	ControllerB	Controller - Base Mounted	0	0 / Continuous	2
X	itssp	ControllerB_ep	Controller - Base Mounted (Existing)	0	2 / DGN2	1
X	itssp	ControllerP	Controller Pole Mount	0	0 / Continuous	2
X	itssp	ControllerP_ep	Controller Pole Mount (Existing)	0	2 / DGN2	1
X	itssp	CrossWalk1	Emphasis Crosswalk 6ft High	0	PM-Stripe-6' Crosswalk	4
X	itssp	CrossWalk2	Emphasis Crosswalk 10ft High	0	PM-Stripe-10' Crosswalk	4
	itssp	CurveData_dp	Curve and Coordinate Data Elements Including PC, PT, PI Symbols	4	0 / Continuous	2
	itssp	CurveDataLabel_dp	Curve Data Labels PC,PI, PT	0	0 / Continuous	2
X	itssp	Delineator	Delineators (All Types)	4	0 / Continuous	1
X	itssp	Detector	Detector Cabinet, Button and Miscellaneous Assemblies	3	0 / Continuous	2
X	itssp	Detector_ep	Detector Cabinet, Button and Miscellaneous Assemblies (Existing)	3	2 / DGN2	1
X	itssp	DetectorVeh	Detector Vehicle Assemblies (All Types)	3	0 / Continuous	1
X	itssp	DetectorVeh_ep	Detector Vehicle Assemblies (All Types) (Existing)	3	2 / DGN2	0
	itssp	DimLines_dp	Dimension Lines, Corresponding Terminators, Equation Lines	0	0 / Continuous	1
X	itssp	DirArrowsPavt	Pavement Marking Directional Arrows	0	0 / Continuous	1
X	itssp	EaseLicLine	Easement License Agreement Line	5	6 / DGN6	0
X	itssp	ElecBur	Electrical (Buried)	3	UT-BuriedElec-Proposed	2
X	itssp	ElecServ	Electrical Service Miscellaneous	3	0 / Continuous	2
X	itssp	ElecServWire	Electrical Service Wire	3	0 / Continuous	2
X	itssp	FO_01Blue	Fiber Optic Buffer Tube, Blue	25	0 / Continuous	2
X	itssp	FO_01Blue_ep	Fiber Optic Buffer Tube, Blue (Existing)	25	2 / DGN2	1
X	itssp	FO_02Orange	Fiber Optic Buffer Tube, Orange	30	0 / Continuous	2
X	itssp	FO_02Orange_ep	Fiber Optic Buffer Tube, Orange (Existing)	30	2 / DGN2	1
X	itssp	FO_03Green	Fiber Optic Buffer Tube, Green	154	0 / Continuous	2
X	itssp	FO_03Green_ep	Fiber Optic Buffer Tube, Green (Existing)	154	2 / DGN2	1
X	itssp	FO_04Brown	Fiber Optic Buffer Tube, Brown	150	0 / Continuous	2
X	itssp	FO_04Brown_ep	Fiber Optic Buffer Tube, Brown (Existing)	150	2 / DGN2	1
X	itssp	FO_05Slate	Fiber Optic Buffer Tube, Slate	152	0 / Continuous	2
X	itssp	FO_05Slate_ep	Fiber Optic Buffer Tube, Slate (Existing)	152	2 / DGN2	1
X	itssp	FO_06White	Fiber Optic Buffer Tube, White	152	0 / Continuous	2
X	itssp	FO_06White_ep	Fiber Optic Buffer Tube, White (Existing)	152	2 / DGN2	1
X	itssp	FO_07Red	Fiber Optic Buffer Tube, Red	27	0 / Continuous	2
X	itssp	FO_07Red_ep	Fiber Optic Buffer Tube, Red (Existing)	27	2 / DGN2	1
X	itssp	FO_08Black	Fiber Optic Buffer Tube, Black	0	0 / Continuous	2
X	itssp	FO_08Black_ep	Fiber Optic Buffer Tube, Black (Existing)	0	2 / DGN2	1
X	itssp	FO_09Yellow	Fiber Optic Buffer Tube, Yellow	28	0 / Continuous	2
X	itssp	FO_09Yellow_ep	Fiber Optic Buffer Tube, Yellow (Existing)	28	2 / DGN2	1
X	itssp	FO_10Purple	Fiber Optic Buffer Tube, Purple	157	0 / Continuous	2



Critical	Rule	Level Name	Level Description	ByLevel Color	ByLevelStyle / Linetype	ByLevel Weight
X	itssp	FO_10Purple_ep	Fiber Optic Buffer Tube, Purple (Existing)	157	2 / DGN2	1
X	itssp	FO_11Rose	Fiber Optic Buffer Tube, Rose	12	0 / Continuous	2
X	itssp	FO_11Rose_ep	Fiber Optic Buffer Tube, Rose (Existing)	12	2 / DGN2	1
X	itssp	FO_12Aqua	Fiber Optic Buffer Tube, Aqua	55	0 / Continuous	2
X	itssp	FO_12Aqua_ep	Fiber Optic Buffer Tube, Aqua (Existing)	55	2 / DGN2	1
X	itssp	FO_Sheath	Fiber Optic Sheath	0	0 / Continuous	2
X	itssp	FO_SpliceCap	Fiber Optic Splice Cap	0	0 / Continuous	2
X	itssp	FO_Stripe	Fiber Optic Buffer Tube, Stripe	0	0 / Continuous	2
X	itssp	FOCBur	Fiber Optics Cable (Buried)	6	UT-BuriedFOC-Proposed	2
X	itssp	FOSheath	Fiber Optic Sheath	0	0 / Continuous	2
X	itssp	FOSpliceCap	Fiber Optic Splice Cap	0	0 / Continuous	2
X	itssp	FOStripe	Fiber Optic Buffer Tube, Stripe	0	0 / Continuous	2
	itssp	GridMaj_dp	Grid Lines Major in Profile and Cross Section	3	0 / Continuous	1
	itssp	GridMin_dp	Grid Lines Minor in Profile and Cross Section	0	0 / Continuous	0
	itssp	GridMinSub_dp	Grid Lines Minor Sub on Cross Section Sheets	20	0 / Continuous	0
	itssp	GSBWFill	GuidSign Black and White Fill Level for GuidSign Cells	0	0 / Continuous	1
	itssp	GSColorFill	GuidSign Color Fill Level for GuidSign Cells	2	0 / Continuous	1
	itssp	GSDims	GuidSign Dimensions	0	0 / Continuous	1
	itssp	GSOOutline	GuidSign Outline Level for GuidSign Cells	0	0 / Continuous	2
	itssp	GSSign	GuidSign Panel and Tag	7	0 / Continuous	0
X	itssp	GuyWire	Guy Wire	3	0 / Continuous	2
X	itssp	HAR	Highway Advisory Radio Unit	3	0 / Continuous	2
X	itssp	HAR_ep	Highway Advisory Radio Unit (Existing)	3	2 / DGN2	1
X	itssp	HubEthernet	Ethernet Hub	1	0 / Continuous	1
X	itssp	HubWireless	Wireless Receiver and Transmitter	3	0 / Continuous	1
	itssp	ImageAttachment_dp	Image Attachments	0	0 / Continuous	0
X	itssp	Insulator	Insulator, Fiberglass	3	0 / Continuous	4
X	itssp	InterconCable	Cable Interconnect	1	SG-InterconCable-Proposed	1
X	itssp	InterconCable_ep	Interconnect Cable (Existing)	1	SG-InterconCable-Existing	0
	itssp	ITSDetail00	ITS Details	0	0 / Continuous	0
	itssp	ITSDetail01	ITS Details	0	0 / Continuous	1
	itssp	ITSDetail02	ITS Details	0	0 / Continuous	2
	itssp	ITSDetail10	ITS Details	1	0 / Continuous	0
	itssp	ITSDetail11	ITS Details	1	0 / Continuous	1
	itssp	ITSDetail12	ITS Details	1	0 / Continuous	2
	itssp	ITSDetail20	ITS Details	2	0 / Continuous	0
	itssp	ITSDetail21	ITS Details	2	0 / Continuous	1
	itssp	ITSDetail22	ITS Details	2	0 / Continuous	2
	itssp	ITSDetail30	ITS Details	3	0 / Continuous	0
	itssp	ITSDetail31	ITS Details	3	0 / Continuous	1
	itssp	ITSDetail32	ITS Details	3	0 / Continuous	2
X	itssp	ITSEquip00	ITS Equipment Racks	0	0 / Continuous	0
X	itssp	ITSEquip01	ITS Equipment Racks	0	0 / Continuous	1
X	itssp	ITSEquip02	ITS Equipment Racks	0	0 / Continuous	2
X	itssp	JunctBoxA	Junction Boxes (Aerial)	3	0 / Continuous	1
X	itssp	JunctBoxA_ep	Junction Boxes (Aerial) (Existing)	3	1 / DGN1	0

Critical	Rule	Level Name	Level Description	ByLevel Color	ByLevelStyle / Linetype	ByLevel Weight
X	itssp	Kiosk	Kiosk	2	0 / Continuous	1
	itssp	LaneDirArrow	Lane Directional Arrow	0	0 / Continuous	1
	itssp	LeaderLine_dp	Leader Line and Terminator with Text	0	0 / Continuous	1
	itssp	LightingMisc	Lighting Items (Miscellaneous)	4	0 / Continuous	2
X	itssp	LightingSP	Lighting Service Points	0	0 / Continuous	1
X	itssp	LoadCenter	Load Center	2	0 / Continuous	1
X	itssp	LoadCenter_ep	Load Center (Existing)	2	5 / DGN5	0
	itssp	Logo_dp	Consultant Engineer of Record Logo	0	0 / Continuous	1
X	itssp	LoopLI	Loop Lead-In	3	0 / Continuous	1
X	itssp	LoopLI_ep	Loop Lead-In (Existing)	3	2 / DGN2	0
X	itssp	Loops	Loop Assembly (All Types)	2	0 / Continuous	2
X	itssp	Loops_ep	Loop Assembly (All Types) (Existing)	2	2 / DGN2	2
X	itssp	Luminaire	Luminaires (Decorative - All Types)	2	0 / Continuous	1
X	itssp	MessengerWire	Messenger Wire	3	0 / Continuous	1
X	itssp	MetalButtons	Metal Buttons	0	0 / Continuous	2
	itssp	Miscellaneous0	Undefined Proposed Item - Color Blue Weight 0	1	0 / Continuous	0
	itssp	Miscellaneous1	Undefined Proposed Item - Color Blue Weight 1	1	0 / Continuous	1
	itssp	Miscellaneous2	Undefined Proposed Item - Color Blue Weight 2	1	0 / Continuous	2
	itssp	Miscellaneous3	Undefined Proposed Item - Color Green Weight 0	2	0 / Continuous	0
	itssp	Miscellaneous4	Undefined Proposed Item - Color Green Weight 1	2	0 / Continuous	1
	itssp	Miscellaneous5	Undefined Proposed Item - Color Green Weight 2	2	0 / Continuous	2
	itssp	Miscellaneous6	Undefined Proposed Item - Color Red Weight 0	3	0 / Continuous	0
	itssp	Miscellaneous7	Undefined Proposed Item - Color Red Weight 1	3	0 / Continuous	1
	itssp	Miscellaneous8	Undefined Proposed Item - Color Red Weight 2	3	0 / Continuous	2
	itssp	Miscellaneous9	Undefined Proposed Item - Color Red Weight 3	3	0 / Continuous	3
	itssp	NonPlottingEle_dp	Non-Plotting Items - Construction Elements, Type 66 Elements, Etc.	4	0 / Continuous	0
	itssp	NorthArw_dp	North Arrows	0	0 / Continuous	2
X	itssp	ObjectMarker	Object and Reflective Markers	3	0 / Continuous	1
X	itssp	OverheadSign	Overhead Sign Panels	0	0 / Continuous	2
X	itssp	OverheadSign_ep	Overhead Sign Panels (Existing)	0	3 / DGN3	1
X	itssp	OverheadStr	Mast Arm, Truss Assemblies, Signal Arms and Supports	0	0 / Continuous	2
X	itssp	OverheadStr_ep	Mast Arm, Truss Assemblies, Signal Arms and Supports (Existing)	0	3 / DGN3	1
	itssp	Pavemk_ep	Pavement Markings (All) (Existing)	0	2 / DGN2	0
X	itssp	PavtMessage	Pavement Message (All Types)	0	0 / Continuous	1
X	itssp	PavtMessage_ep	Pavement Message (All Types) (Existing)	0	2 / DGN2	0
	itssp	PayItem_dp	Pay Item Number Label Elements	4	0 / Continuous	2
X	itssp	PedDetector	Pedestrian Detector	0	0 / Continuous	2
X	itssp	Pedestal	Pedestal	1	0 / Continuous	1
X	itssp	Pedestal_ep	Pedestal (Existing)	1	2 / DGN2	1
X	itssp	PedHead	Pedestrian Head (All Types)	1	0 / Continuous	1
X	itssp	PedHead_ep	Pedestrian Head (All Types) (Existing)	0	2 / DGN2	1
X	itssp	PlotBorder_dp	Plot Border	3	0 / Continuous	0
X	itssp	PMCeramic	Pavement Markers Ceramic	0	0 / Continuous	1
	itssp	PMMisc	Pavement Marking Items (Miscellaneous)	0	0 / Continuous	2
X	itssp	PMStripe(10-10-20)	Pavement Marking 10/10/20 Skip Traffic Stripe 6in Contrast	0	PM-Stripe-10'_20'Skip / PM-Stripe-SKIP 10-10-20	2
X	itssp	PMStripe(2-2-2)	Pavement Marking 2/2/2 Skip Traffic Stripe 6in Contrast	0	PM-Stripe-2'_2'Skip / PM-Stripe-SKIP 2-2-2	2

Critical	Rule	Level Name	Level Description	ByLevel Color	ByLevelStyle / Linetype	ByLevel Weight
X	itssp	PMStripe12B	Pavement Marking Traffic Stripe 12in Black	3	0 / Continuous	4
X	itssp	PMStripe12W	Pavement Marking Traffic Stripe 12in White	0	0 / Continuous	4
X	itssp	PMStripe12W(2-4)	Pavement Marking 2/4 Skip Traffic Stripe 12in White	0	0 / PM-Stripe-SKIP 2-4	4
X	itssp	PMStripe12W(3-9)	Pavement Marking 3/9 Skip Traffic Stripe 12in White	0	0 /PM-Stripe-SKIP 3-9	4
X	itssp	PMStripe12Y	Pavement Marking Traffic Stripe 12in Yellow	4	0 / Continuous	4
X	itssp	PMStripe16B	Pavement Marking Traffic Stripe 16in Black	3	0 / Continuous	5
X	itssp	PMStripe16W	Pavement Marking Traffic Stripe 16in White	0	0 / Continuous	5
X	itssp	PMStripe16Y	Pavement Marking Traffic Stripe 16in Yellow	4	0 / Continuous	5
X	itssp	PMStripe18B	Pavement Marking Traffic Stripe 18in Black	3	0 / Continuous	6
X	itssp	PMStripe18W	Pavement Marking Traffic Stripe 18in White	0	0 / Continuous	6
X	itssp	PMStripe18Y	Pavement Marking Traffic Stripe 18in Yellow	4	0 / Continuous	6
X	itssp	PMStripe24W	Pavement Marking Traffic Stripe 24in White	0	0 / Continuous	7
X	itssp	PMStripe24Y	Pavement Marking Traffic Stripe 24in Yellow	4	0 / Continuous	7
X	itssp	PMStripe6B	Pavement Marking Traffic Stripe 6in Black	3	0 / Continuous	2
X	itssp	PMStripe6B(10-30)	Pavement Marking 10/30 Skip Traffic Stripe 6in Black	3	0 /PM-Stripe-SKIP 10-30	2
X	itssp	PMStripe6Bl	Pavement Marking Traffic Stripe 6in Blue	1	0 / Continuous	2
X	itssp	PMStripe6DY	Pavement Marking Traffic Stripe 6in Double Yellow	4	0 / Continuous	2
X	itssp	PMStripe6W	Pavement Marking Traffic Stripe 6in White	0	0 / Continuous	2
X	itssp	PMStripe6W(10-30)	Pavement Marking 10/30 Skip Traffic Stripe 6in White	0	0 /PM-Stripe-SKIP 10-30	2
X	itssp	PMStripe6W(2-4)	Pavement Marking 2/4 Skip Traffic Stripe 6in White	0	0 /PM-Stripe-SKIP 2-4	2
X	itssp	PMStripe6W(3-9)	Pavement Marking 3/9 Skip Traffic Stripe 6in White	0	0 /PM-Stripe-SKIP 3-9	2
X	itssp	PMStripe6W(6-10)	Pavement Marking 6/10 Skip Traffic Stripe 6in White	0	0 /PM-Stripe-SKIP 6-10	2
X	itssp	PMStripe6Y	Pavement Marking Traffic Stripe 6in Yellow	4	0	2
X	itssp	PMStripe6Y(10-30)	Pavement Marking 10/30 Skip Traffic Stripe 6in Yellow	4	0 /PM-Stripe-SKIP 10-30	2
X	itssp	PMStripe6Y(2-4)	Pavement Marking 2/4 Skip Traffic Stripe 6in Yellow	4	0 /PM-Stripe-SKIP 2-4	2
X	itssp	PMStripe6Y(6-10)	Pavement Marking 6/10 Skip Traffic Stripe 6in Yellow	4	0 /PM-Stripe-SKIP 6-10	2
X	itssp	PMStripe8B	Pavement Marking Traffic Stripe 8in Black	3	0 / Continuous	3
X	itssp	PMStripe8W	Pavement Marking Traffic Stripe 8in White	0	0 / Continuous	3
X	itssp	PMStripe8W(3-9)	Pavement Marking 3/9 Skip Traffic Stripe 8in White	0	PM-Stripe-SKIP 3-9	2
X	itssp	PMStripe8Y	Pavement Marking Traffic Stripe 8in Yellow	4	0 / Continuous	3
X	itssp	PMStripe9C(10-30)	Pavement Marking 10/30 Skip Traffic Stripe 9in Contrast	0	0 / PM-Stripe-SKIP 10-30	2
X	itssp	PMStripeRumbleCL	Center Line Rumble Stripes (Use to Quantify Rumble Strips) (NonPlotting)	4	PM-Stripe-RumbleStripeLeft / PM-Stripe-RumbleStripe	2
X	itssp	PMStripeRumbleWL	Rumble Stripes (6in White Thermoplastic Over Rumble Strips) (Left)	0	PM-Stripe-RumbleStripeLeft / PM-Stripe-RumbleStripe	2
X	itssp	PMStripeRumbleWR	Rumble Stripes (6in White Thermoplastic Over Rumble Strips) (Right)	0	PM-Stripe-RumbleStripeRight / PM-Stripe-RumbleStripe	2
X	itssp	PMStripeRumbleYL	Rumble Stripes (6in Yellow Thermoplastic Over Rumble Strips) (Left)	4	PM-Stripe-RumbleStripeLeft / PM-Stripe-RumbleStripe	2
X	itssp	PMStripeRumbleYR	Rumble Stripes (6in Yellow Thermoplastic Over Rumble Strips) (Right)	4	PM-Stripe-RumbleStripeRight / PM-Stripe-RumbleStripe	2
X	itssp	PMStripeVibeWL	Pavement Marking Auditory and Vibratory 6in White (Left)	0	PM-Stripe-VibratoryLeft /PM-Stripe-Vibratory	2
X	itssp	PMStripeVibeWR	Pavement Marking Auditory and Vibratory 6in White (Right)	0	PM-Stripe-VibratoryRight /PM-Stripe-Vibratory	2
X	itssp	PMStripeVibeYL	Pavement Marking Auditory and Vibratory 6in Yellow (Left)	4	PM-Stripe-VibratoryLeft /PM-Stripe-Vibratory	2
X	itssp	PMStripeVibeYR	Pavement Marking Auditory and Vibratory 6in Yellow (Right)	4	PM-Stripe-VibratoryRight /PM-Stripe-Vibratory	2
X	itssp	PointLocator_ep	Point Locator Symbol (Existing)	4	0 / Continuous	0
X	itssp	PoleConc	Concrete Strain Pole	0	0 / Continuous	2
X	itssp	PoleConc_ep	Concrete Strain Pole (Existing)	0	2 / DGN2	1

Critical	Rule	Level Name	Level Description	ByLevel Color	ByLevelStyle / Linetype	ByLevel Weight
X	itssp	PoleElec	Electrical Pole w/ Transformer	3	0 / Continuous	2
X	itssp	PoleFound	Pole Foundation	0	0 / Continuous	2
X	itssp	PoleLight	Light Pole	2	0 / Continuous	1
X	itssp	PoleLight_ep	Light Pole (Existing)	2	2 / DGN2	1
X	itssp	PoleLightHM	High Mast Light Pole	3	0 / Continuous	1
X	itssp	PoleLightHM_ep	High Mast Light Pole (Existing)	2	2 / DGN2	1
	itssp	PoleLightID	Light Pole Location / ID	4	0 / Continuous	1
X	itssp	PoleShared	Power Pole Electric (Above Ground) Shared w/ Transformer	3	0 / Continuous	2
X	itssp	PoleSteelStrain	Steel Strain Pole	0	0 / Continuous	2
X	itssp	PoleSteelStrain_ep	Steel Strain Pole (Existing)	0	2 / DGN2	1
X	itssp	PoleUtil	Utility Pole	0	0 / Continuous	2
X	itssp	PoleWoodStrain	Wood Strain Pole	0	0 / Continuous	2
X	itssp	PoleWoodStrain_ep	Wood Strain Pole (Existing)	0	2 / DGN2	1
X	itssp	PullBox	Pull Boxes (All Types)	3	0 / Continuous	1
	itssp	ReferencePt_dp	Survey and Construction Reference Point Details and Elements	4	0 / Continuous	2
X	itssp	ReflPaintWht	Reflective Paint - Island Nose (White)	0	0 / Continuous	3
X	itssp	ReflPaintYel	Reflective Paint - Island Nose (Yellow)	4	0 / Continuous	3
X	itssp	RPM_ep	Reflective Pavement Markers (Existing)	2	2 / DGN2	1
X	itssp	RPM1	Raised Pavement Markers, White	0	0 / Continuous	2
X	itssp	RPM2	Raised Pavement Markers, White - Red	3	0 / Continuous	2
X	itssp	RPM3	Raised Pavement Markers, Yellow	4	0 / Continuous	2
X	itssp	RPM4	Raised Pavement Markers, Yellow - Yellow	9	0 / Continuous	2
X	itssp	RPM5	Raised Pavement Markers, Yellow - Red	6	0 / Continuous	2
X	itssp	RPM6	Raised Pavement Markers, Blue	1	0 / Continuous	2
X	itssp	SawCuts	Saw Cuts	3	3 / DGN3	0
	itssp	Scale_dp	Bar Scale, Scale Label Elements	0	0 / Continuous	2
	itssp	Scratch1_dp	Scratch Level for Temporary or Informational Items	4	0 / Continuous	0
	itssp	Scratch2_dp	Scratch Level for Temporary or Informational Items	5	0 / Continuous	0
	itssp	ScratchEle_dp	Scratch Level for Draft Elements, Temporary Elements, Etc. (DO NOT PLOT)	3	0 / Continuous	0
	itssp	ScratchEle2_dp	Scratch Level for Draft Elements, Temporary Elements, Etc. (DO NOT PLOT)	4	0 / Continuous	0
	itssp	SheetBorder_dp	Sheet Border	1	0 / Continuous	4
	itssp	SheetLines_dp	Sheet Lines	1	0 / Continuous	2
	itssp	SheetLinesMisc1_dp	Sheet Lines	1	0 / Continuous	0
	itssp	SheetLinesMisc2_dp	Sheet Lines	2	0 / Continuous	2
	itssp	SheetLinesMisc3_dp	Sheet Lines	3	0 / Continuous	2
	itssp	SheetLinesMisc4_dp	Sheet Lines	4	0 / Continuous	2
X	itssp	SignalCable	Signal Cable	3	SG-Cable / Continuous	1
X	itssp	SignalCableAccs	Signal Cable Accessories	0	0 / Continuous	2
X	itssp	SignalDetail	Signal Details	0	0 / Continuous	1
	itssp	SignalHead	Signal Head Section Details	2	0 / Continuous	1
X	itssp	SignalHead_ep	Signal Head Section Details (Existing)	2	2 / DGN2	0
	itssp	SignalMisc	Signal Equipment (Miscellaneous)	3	0 / Continuous	1
X	itssp	SignalSOP	S.O.P. Box and Movements	0	0 / Continuous	2
X	itssp	SignalSym	Signal Head Symbols	0	0 / Continuous	1
X	itssp	SignalSym_ep	Signal Head Symbols (Existing)	3	2 / DGN2	0
X	itssp	SignCantilever	Sign Symbol Cantilever	0	0 / Continuous	1

Critical	Rule	Level Name	Level Description	ByLevel Color	ByLevelStyle / Linetype	ByLevel Weight
X	itssp	SignCantilever_ep	Sign Symbol Cantilever (Existing)	0	2 / DGN2	0
	itssp	SignDetail	Sign Details	0	0 / Continuous	2
	itssp	SignLettersAZ	Alphabet Cell Library Letter A-Z Numbers 0-9	0	0 / Continuous	0
	itssp	SignMisc	Sign Symbols (Miscellaneous)	3	0 / Continuous	1
	itssp	SignMisc_ep	Sign Symbols (Miscellaneous) (Existing)	1	1 / DGN1	1
X	itssp	SignPanel	Sign Panels - Regulatory	0	0 / Continuous	2
X	itssp	SignPanel_ep	Sign Panel Elements (Existing)	0	2 / DGN2	1
X	itssp	SignPanelBorder	Sign Panel Border on Sign Details	0	0 / Continuous	1
X	itssp	SignPanelC	Sign Panels - Civil	1	0 / Continuous	2
X	itssp	SignPanelDetRed	Sign Panel Details in Red	3	0 / Continuous	2
X	itssp	SignPanelG	Sign Panels - Guide	2	0 / Continuous	2
X	itssp	SignPanell	Sign Panels - Special Interest	9	0 / Continuous	2
X	itssp	SignPanelT	Sign Panels - Construction	6	0 / Continuous	2
X	itssp	SignPanelW	Sign Panels - Warning	4	0 / Continuous	2
X	itssp	SignSpanwire	Span Wire Signing Assembly	2	0 / Continuous	1
X	itssp	SignSpanwire_ep	Span Wire Signing Assembly (Existing)	2	2 / DGN2	1
X	itssp	SignSpecial	Special Signs / Guide Signs	2	0 / Continuous	2
X	itssp	SignSupport	Ground Mounted Sign Support Symbol (All Types)	1	0 / Continuous	1
X	itssp	SignSymbol_px	Sign Structure and Foundation on Cross Sections	4	0 / Continuous	2
X	itssp	SignTruss	Sign Symbol Truss	3	0 / Continuous	1
X	itssp	SignTruss_ep	Sign Symbol Truss (Existing)	3	2 / DGN2	1
	itssp	SpecialDetails	Special Details	6	0 / Continuous	1
X	itssp	SpliceBox	Fiber Optic Splice Box	3	0 / Continuous	1
X	itssp	SpliceBox_ep	Fiber Optic Splice Box (Existing)	3	2 / DGN2	0
	itssp	StationTicL_dp	Station Tic Marks (Large) and Text	0	0 / Continuous	2
	itssp	StationTicS_dp	Station Tic Marks (Small) and Text	0	0 / Continuous	2
	itssp	SumBoxBorder_dp	Summary Boxes Borders	4	0 / Continuous	3
	itssp	SumBoxLines_dp	Summary Boxes Lines and Miscellaneous Items	4	0 / Continuous	1
	itssp	SumBoxLinesMin_dp	Summary Boxes Lines Minor Line and Miscellaneous Items	4	0 / Continuous	0
	itssp	Tables_dp	Data Tables and All Autodesk Tables	0	0 / Continuous	1
	itssp	TextBLStation	Text - B/L Station and Tics	0	0 / Continuous	2
	itssp	TextConstEle	Text - Construction Element	0	0 / Continuous	1
	itssp	TextCurveData	Text - Curve Data Note	0	0 / Continuous	2
	itssp	TextDetails	Text - Detail Notes	4	0 / Continuous	2
	itssp	TextDrainInvElev_ep	Text - Drainage Invert Elevation (Existing)	0	0 / Continuous	1
	itssp	TextDrainLabel_ep	Text - Drainage (Existing)	0	0 / Continuous	1
	itssp	TextElevLabel	Text - Elevation Labels	4	0 / Continuous	0
	itssp	TextLabel	Text - Label	0	0 / Continuous	2
	itssp	TextLandscape	Text - Landscape Labels	0	0 / Continuous	1
	itssp	TextMajor	Text - Major	0	0 / Continuous	5
	itssp	TextMinor	Text - Minor	0	0 / Continuous	0
	itssp	TextMisc	Text - Miscellaneous	0	0 / Continuous	1
	itssp	TextNotes	Text - Notes	4	0 / Continuous	1
	itssp	TextProfLabel	Text - Profile, Horizontal and Vertical Axis Labels	0	0 / Continuous	2
	itssp	TextProjLabel	Text - Begin and End Project Label with Leader Lines	1	0 / Continuous	2
	itssp	TextPtLabel	Text - Point Labels	4	0 / Continuous	0

Critical	Rule	Level Name	Level Description	ByLevel Color	ByLevelStyle / Linetype	ByLevel Weight
	itssp	TextShtNo	Text - Sheet Number	0	0 / Continuous	2
	itssp	TextSubUtilLabel_ep	Text - Subsurface Utilities (Existing)	0	0 / Continuous	1
	itssp	TextSurveyLabel	Text - Survey Labels	0	0 / Continuous	0
	itssp	TextTables	Text - Key Sheet Indexes and Table Data	4	0 / Continuous	2
	itssp	TextTitle	Text - Title	0	0 / Continuous	3
	itssp	TextTopoLabel_ep	Text - Topography (Existing)	0	0 / Continuous	1
	itssp	TextUtilLabel_ep	Text - Utilities (Existing)	0	0 / Continuous	1
	itssp	TextXSElev	Text - Cross Section Elevations	2	0 / Continuous	1
X	itssp	TMC	Traffic Management Center	1	0 / Continuous	1
X	itssp	TollReader	Electronic Toll Reader	3	0 / Continuous	1
X	itssp	TollReader_ep	Electronic Toll Reader (Existing)	3	2 / DGN2	0
	itssp	Viewport	Viewport (For AutoCAD Use)	3	0 / Continuous	0
	itssp	Xreference01_dp	Reference Files (For AutoCAD Use)	0	0 / Continuous	1
	itssp	Xreference02_dp	Reference Files (For AutoCAD Use)	0	0 / Continuous	1
	itssp	Xreference03_dp	Reference Files (For AutoCAD Use)	0	0 / Continuous	1
	itssp	Xreference04_dp	Reference Files (For AutoCAD Use)	0	0 / Continuous	1
	itssp	XSCell	GEOPAK Cross Section Cell/Block and Profile Cell/Block	8	0 / Continuous	1

## KEYSHT - Key Sheets

Critical	Rule	Level Name	Level Description	ByLevel Color	ByLevelStyle / Linetype	ByLevel Weight
	keysht	ActivePointCell_dp	Active Point Cell	4	0 / Continuous	10
	keysht	AdhocPoint_dp	Adhoc Points Placed by SheetInfo	0	4 / DGN4	0
	keysht	BaselineSurvey	Baseline Survey	0	0 / Continuous	2
X	keysht	BoxCulvert	Box Culvert	10	0 / Continuous	2
	keysht	CLConst_dp	Center Line of Construction	0	0 / Continuous	2
	keysht	ClipBorder_dp	CLIP Border and Civil 3D View Frame	3	0 / Continuous	0
	keysht	ClipDrawingBound_dp	CLIP Drawing Boundary	3	3 / DGN3	0
	keysht	Cloud_dp	Construction Cloud	7	0 / Continuous	2
	keysht	COGO_dp	COGO Information	3	0 / Continuous	1
	keysht	ConstArea_dp	Construction Area Crosshatch	0	0 / Continuous	1
	keysht	ConstLimits	Construction Limits	3	RW-LimitsofConst	2
	keysht	ConstLines	Construction Lines and References	1	0 / Continuous	0
	keysht	ConstLines_pm	Construction Lines	4	0 / Continuous	0
	keysht	CurveData_dp	Curve and Coordinate Data Elements Including PC, PT, PI Symbols	4	0 / Continuous	2
	keysht	CurveDataLabel_dp	Curve Data Labels PC,PI, PT	0	0 / Continuous	2
	keysht	DimLines_dp	Dimension Lines, Corresponding Terminators, Equation Lines	0	0 / Continuous	1
X	keysht	DrainStruct_pr	Drainage Structures (All Types)	10	0 / Continuous	2
X	keysht	EaseLicLine	Easement License Agreement Line	5	6 / DGN6	0
X	keysht	Endwall	Endwall (All Types)	10	0 / Continuous	2
X	keysht	FES	Flared End Sections	10	0 / Continuous	2
	keysht	FLMap1	Florida Map items - Weight of 1	1	0 / Continuous	1
	keysht	FLMap2	Florida Map items - Weight of 2	3	0 / Continuous	2
	keysht	FLMap3	Florida Map items - Weight of 3	2	0 / Continuous	3



Critical	Rule	Level Name	Level Description	ByLevel Color	ByLevelStyle / Linetype	ByLevel Weight
	keysht	FLMap4	Florida Map items - Color 11 (Interstate)	11	0 / Continuous	3
	keysht	FLMap5	Florida Map items - Style 7, Wt. 5 (State Line)	3	7 / DGN7	5
X	keysht	GovTwpRgeLine_ep	Township / Range Lines (Existing)	10	RW-TownshipRange	2
	keysht	GradeLine_er	Grade Line Profile (Existing)	2	2 / DGN2	1
	keysht	GradeLine_pr	Grade Line Profile	5	0 / Continuous	2
	keysht	GradeLineCtr_dp	Grade Line Profile Center (Shown in Plan View)	5	0 / Continuous	0
	keysht	GradeLineCtr_pr	Grade Line Profile Center	5	0 / Continuous	2
	keysht	GradeLineLt_dp	Grade Line Profile Left (Shown in Plan View)	1	0 / Continuous	0
	keysht	GradeLineLt_er	Grade Line Profile Left (Existing)	1	2 / DGN2	1
	keysht	GradeLineLt_pr	Grade Line Profile Left	1	0 / Continuous	2
	keysht	GradeLineRt_dp	Grade Line Profile Right (shown in plan vie Shown in Plan View w)	4	0 / Continuous	0
	keysht	GradeLineRt_er	Grade Line Profile Right (Existing)	4	2 / DGN2	1
	keysht	GradeLineRt_pr	Grade Line Profile Right	4	0 / Continuous	2
	keysht	GradeSecPat	Grade Section Patterns	0	0 / Continuous	0
	keysht	GridMaj_dp	Grid Lines Major in Profile and Cross Section	3	0 / Continuous	1
	keysht	GridMin_dp	Grid Lines Minor in Profile and Cross Section	0	0 / Continuous	0
	keysht	GridMinSub_dp	Grid Lines Minor Sub on Cross Section Sheets	20	0 / Continuous	0
	keysht	ImageAttachment_dp	Image Attachments	0	0 / Continuous	0
X	keysht	InletBottomJ	Inlet Bottom Type J	10	0 / Continuous	1
X	keysht	InletBottomP	Inlet Bottom Type P	10	0 / Continuous	1
X	keysht	InletClosedFlume	Closed Flume Inlet	10	0 / Continuous	2
X	keysht	InletCurb	Curb Inlet (All Types)	10	0 / Continuous	2
X	keysht	InletDBI	Ditch Bottom Inlet (All Types)	10	0 / Continuous	2
X	keysht	InletGutter	Gutter Inlet (All Types)	10	0 / Continuous	2
X	keysht	InletMedian	Median Barrier Inlet	10	0 / Continuous	2
	keysht	KeyShtMisc	Key Sheet Items (Miscellaneous)	0	0 / Continuous	2
	keysht	LaneDirArrow	Lane Directional Arrow	0	0 / Continuous	1
	Keysht	LaneLine	Lane Lines (Defines Changes in Pavement Cross Slope) (Non-plotting)	4	3 / DGN3	2
	keysht	LeaderLine_dp	Leader Line and Terminator with Text	0	0 / Continuous	1
	keysht	Logo_dp	Consultant Engineer of Record Logo	0	0 / Continuous	1
X	keysht	Manhole	Manhole (Drainage and Unknown)	10	0 / Continuous	2
	keysht	MapOutline_dp	Outline for Key Maps	0	0 / Continuous	5
	keysht	MatchLines_dp	Match Lines with Text, Arrows for Station Notations	1	0 / Continuous	2
X	keysht	MES	Mitered End Section	10	0 / Continuous	2
	keysht	Miscellaneous0	Undefined Proposed Item - Color Blue Weight 0	1	0 / Continuous	0
	keysht	Miscellaneous1	Undefined Proposed Item - Color Blue Weight 1	1	0 / Continuous	1
	keysht	Miscellaneous2	Undefined Proposed Item - Color Blue Weight 2	1	0 / Continuous	2
	keysht	Miscellaneous3	Undefined Proposed Item - Color Green Weight 0	2	0 / Continuous	0
	keysht	Miscellaneous4	Undefined Proposed Item - Color Green Weight 1	2	0 / Continuous	1
	keysht	Miscellaneous5	Undefined Proposed Item - Color Green Weight 2	2	0 / Continuous	2
	keysht	Miscellaneous6	Undefined Proposed Item - Color Red Weight 0	3	0 / Continuous	0
	keysht	Miscellaneous7	Undefined Proposed Item - Color Red Weight 1	3	0 / Continuous	1
	keysht	Miscellaneous8	Undefined Proposed Item - Color Red Weight 2	3	0 / Continuous	2
	keysht	Miscellaneous9	Undefined Proposed Item - Color Red Weight 3	3	0 / Continuous	3
	keysht	NonPlottingEle_dp	Non-Plotting Items - Construction Elements, Type 66 Elements, Etc.	4	0 / Continuous	0
	keysht	NorthArw_dp	North Arrows	0	0 / Continuous	2

Critical	Rule	Level Name	Level Description	ByLevel Color	ByLevelStyle / Linetype	ByLevel Weight
	keysht	PatternLines1_dp	Pattern Lines on Cross Sections and All Autodesk (Civil 3D) Tables	3	0 / Continuous	2
	keysht	PatternLines2_dp	Pattern Lines on Cross Sections Alternate for Side Streets, Critical Cross Sections or Drainage Structures	4	0 / Continuous	2
	keysht	PatternLines3_dp	Pattern Lines on Cross Sections Alternate for Side Streets, Critical Cross Sections or Drainage Structures	5	0 / Continuous	2
	keysht	PayItem_dp	Pay Item Number Label Elements	4	0 / Continuous	2
X	keysht	PlotBorder_dp	Plot Border	3	0 / Continuous	0
	keysht	PointLocator_ep	Point Locator Symbol (Existing)	4	0 / Continuous	0
	keysht	RailroadDetails	Railroad Crossing Details	3	0 / Continuous	2
	keysht	RailroadXing	Railroad Crossing Elements	11	0 / Continuous	0
	keysht	ReferencePt_dp	Survey and Construction Reference Point Details and Elements	4	0 / Continuous	2
	keysht	RoadwayMisc	Roadway Items (Miscellaneous)	4	0 / Continuous	2
	keysht	Scale_dp	Bar Scale, Scale Label Elements	0	0 / Continuous	2
	keysht	Scratch1_dp	Scratch Level for Temporary or Informational Items	4	0 / Continuous	0
	keysht	Scratch2_dp	Scratch Level for Temporary or Informational Items	5	0 / Continuous	0
	keysht	ScratchEle_dp	Scratch Level for Draft Elements, Temporary Elements, Etc. (DO NOT PLOT)	3	0 / Continuous	0
	keysht	ScratchEle2_dp	Scratch Level for Draft Elements, Temporary Elements, Etc. (DO NOT PLOT)	4	0 / Continuous	0
	keysht	SheetBorder_dp	Sheet Border	1	0 / Continuous	4
	keysht	SheetLines_dp	Sheet Lines	1	0 / Continuous	2
	keysht	SheetLinesMisc1_dp	Sheet Lines	1	0 / Continuous	0
	keysht	SheetLinesMisc2_dp	Sheet Lines	2	0 / Continuous	2
	keysht	SheetLinesMisc3_dp	Sheet Lines	3	0 / Continuous	2
	keysht	SheetLinesMisc4_dp	Sheet Lines	4	0 / Continuous	2
	keysht	StationTicL_dp	Station Tic Marks (Large) and Text	0	0 / Continuous	2
	keysht	StationTicS_dp	Station Tic Marks (Small) and Text	0	0 / Continuous	2
	keysht	SumBoxBorder_dp	Summary Boxes Borders	4	0 / Continuous	3
	keysht	SumBoxLines_dp	Summary Boxes Lines and Miscellaneous Items	4	0 / Continuous	1
	keysht	SumBoxLinesMin_dp	Summary Boxes Lines Minor Line and Miscellaneous Items	4	0 / Continuous	0
	keysht	Tables_dp	Data Tables and All Autodesk Tables	0	0 / Continuous	1
	keysht	TextBLStation	Text - B/L Station and Tics	0	0 / Continuous	2
	keysht	TextConstEle	Text - Construction Element	0	0 / Continuous	1
	keysht	TextCurveData	Text - Curve Data Note	0	0 / Continuous	2
	keysht	TextDetails	Text - Detail Notes	4	0 / Continuous	2
	keysht	TextDrainInvElev_ep	Text - Drainage Invert Elevation (Existing)	0	0 / Continuous	1
	keysht	TextDrainLabel_ep	Text - Drainage (Existing)	0	0 / Continuous	1
	keysht	TextElevLabel	Text - Elevation Labels	4	0 / Continuous	0
	keysht	TextLabel	Text - Label	0	0 / Continuous	2
	keysht	TextLandscape	Text - Landscape Labels	0	0 / Continuous	1
	keysht	TextMajor	Text - Major	0	0 / Continuous	5
	keysht	TextMinor	Text - Minor	0	0 / Continuous	0
	keysht	TextMisc	Text - Miscellaneous	0	0 / Continuous	1
	keysht	TextNotes	Text - Notes	4	0 / Continuous	1
	keysht	TextProfLabel	Text - Profile, Horizontal and Vertical Axis Labels	0	0 / Continuous	2
	keysht	TextProjLabel	Text - Begin and End Project Label with Leader Lines	1	0 / Continuous	2
	keysht	TextPtLabel	Text - Point Labels	4	0 / Continuous	0
	keysht	TextShtNo	Text - Sheet Number	0	0 / Continuous	2
	keysht	TextSubUtilLabel_ep	Text - Subsurface Utilities (Existing)	0	0 / Continuous	1



Critical	Rule	Level Name	Level Description	ByLevel Color	ByLevelStyle / Linetype	ByLevel Weight
	keysht	TextSurveyLabel	Text - Survey Labels	0	0 / Continuous	0
	keysht	TextTables	Text - Key Sheet Indexes and Table Data	4	0 / Continuous	2
	keysht	TextTitle	Text - Title	0	0 / Continuous	3
	keysht	TextTopoLabel_ep	Text - Topography (Existing)	0	0 / Continuous	1
	keysht	TextUtilLabel_ep	Text - Utilities (Existing)	0	0 / Continuous	1
	keysht	TextXSElev	Text - Cross Section Elevations	2	0 / Continuous	1
	keysht	Viewport	Viewport (For AutoCAD Use)	3	0 / Continuous	0
	keysht	Xreference01_dp	Reference Files (For AutoCAD Use)	0	0 / Continuous	1
	keysht	Xreference02_dp	Reference Files (For AutoCAD Use)	0	0 / Continuous	1
	keysht	Xreference03_dp	Reference Files (For AutoCAD Use)	0	0 / Continuous	1
	keysht	Xreference04_dp	Reference Files (For AutoCAD Use)	0	0 / Continuous	1
	keysht	XSCell	GEOPAK Cross Section Cell/Block and Profile Cell/Block	8	0 / Continuous	1

## MSARSP - Mast Arm Details

Critical	Rule	Level Name	Level Description	ByLevel Color	ByLevelStyle / Linetype	ByLevel Weight
	msarsp	ActivePointCell_dp	Active Point Cell	4	0 / Continuous	10
	msarsp	AdhocPoint_dp	Adhoc Points Placed by SheetInfo	0	4 / DGN4	0
	msarsp	COGO_dp	COGO Information	3	0 / Continuous	1
X	msarsp	ConduitAG	Conduit (Above Ground)	4	SG-ConduitAG-Proposed	1
X	msarsp	ConduitBM	Conduit – Bridge Mount	5	SG-ConduitBM-Proposed	1
X	msarsp	ConduitDB	Conduit – Directional Bore	2	SG-ConduitDB-Proposed	1
X	msarsp	ConduitJB	Conduit – Jack & Bore Under Rail	3	SG-ConduitJB-Proposed	1
X	msarsp	ConduitOT	Conduit – Open Trench	1	SG-ConduitOT-Proposed	1
	msarsp	ConstLines	Construction Lines and References	1	0 / Continuous	0
	msarsp	ConstLines_pm	Construction Lines	4	0 / Continuous	0
X	msarsp	Controller	Controller and Accessories	0	0 / Continuous	2
X	msarsp	Controller_ep	Controller and Accessories (Existing)	0	2 / DGN2	1
X	msarsp	ControllerAccess	Controller Accessories	0	0 / Continuous	1
X	msarsp	ControllerB	Controller - Base Mounted	0	0 / Continuous	2
X	msarsp	ControllerB_ep	Controller - Base Mounted (Existing)	0	2 / DGN2	1
X	msarsp	ControllerP	Controller Pole Mount	0	0 / Continuous	2
X	msarsp	ControllerP_ep	Controller Pole Mount (Existing)	0	2 / DGN2	1
X	msarsp	Detector	Detector Cabinet, Button and Miscellaneous Assemblies	3	0 / Continuous	2
X	msarsp	DetectorVeh	Detector Vehicle Assemblies (All Types)	3	0 / Continuous	1
	msarsp	DimLines_dp	Dimension Lines, Corresponding Terminators, Equation Lines	0	0 / Continuous	1
X	msarsp	EaseLicLine	Easement License Agreement Line	5	6 / DGN6	0
X	msarsp	ElecBur	Electrical (Buried)	3	UT-BuriedElec-Proposed	2
X	msarsp	ElecServ	Electrical Service (Miscellaneous)	3	0 / Continuous	2
X	msarsp	ElecServWire	Electrical Service Wire	3	0 / Continuous	2
X	msarsp	FOCBur	Fiber Optics Cable (Buried)	6	UT-BuriedFOC-Proposed	2
	msarsp	GridMaj_dp	Grid Lines Major in Profile and Cross Section	3	0 / Continuous	1
	msarsp	GridMin_dp	Grid Lines Minor in Profile and Cross Section	0	0 / Continuous	0
	msarsp	GridMinSub_dp	Grid Lines Minor Sub on Cross Section Sheets	20	0 / Continuous	0

Critical	Rule	Level Name	Level Description	ByLevel Color	ByLevelStyle / Linetype	ByLevel Weight
	mrarsp	ImageAttachment_dp	Image Attachments	0	0 / Continuous	0
X	msarsp	Insulator	Insulator, Fiberglass	3	0 / Continuous	4
X	msarsp	InterconCable	Cable Interconnect	1	SG-InterconCable-Proposed	1
X	msarsp	InterconCable_ep	Interconnect Cable (Existing)	1	SG-InterconCable-Existing	0
X	msarsp	JunctBoxA	Junction Boxes (Aerial)	3	0 / Continuous	1
X	msarsp	JunctBoxA_ep	Junction Boxes (Aerial) (Existing)	3	1 / DGN1	0
	msarsp	LeaderLine_dp	Leader Line and Terminator with Text	0	0 / Continuous	1
X	msarsp	LoadCenter	Load Center	2	0 / Continuous	1
X	msarsp	LoadCenter_ep	Load Center (Existing)	2	5 / DGN5	0
X	msarsp	LoopLI	Loop Lead-In	3	0 / Continuous	1
X	msarsp	LoopLI_ep	Loop Lead-In (Existing)	3	2 / DGN2	0
X	msarsp	Loops	Loop Assembly (All Types)	2	0 / Continuous	2
X	msarsp	Loops_ep	Loop Assembly (All Types) (Existing)	2	2 / DGN2	2
X	msarsp	MessengerWire	Messenger Wire	3	0 / Continuous	1
	msarsp	Miscellaneous0	Undefined Proposed Item - Color Blue Weight 0	1	0 / Continuous	0
	msarsp	Miscellaneous1	Undefined Proposed Item - Color Blue Weight 1	1	0 / Continuous	1
	msarsp	Miscellaneous2	Undefined Proposed Item - Color Blue Weight 2	1	0 / Continuous	2
	msarsp	Miscellaneous3	Undefined Proposed Item - Color Green Weight 0	2	0 / Continuous	0
	msarsp	Miscellaneous4	Undefined Proposed Item - Color Green Weight 1	2	0 / Continuous	1
	msarsp	Miscellaneous5	Undefined Proposed Item - Color Green Weight 2	2	0 / Continuous	2
	msarsp	Miscellaneous6	Undefined Proposed Item - Color Red Weight 0	3	0 / Continuous	0
	msarsp	Miscellaneous7	Undefined Proposed Item - Color Red Weight 1	3	0 / Continuous	1
	msarsp	Miscellaneous8	Undefined Proposed Item - Color Red Weight 2	3	0 / Continuous	2
	msarsp	Miscellaneous9	Undefined Proposed Item - Color Red Weight 3	3	0 / Continuous	3
	msarsp	NonPlottingEle_dp	Non-Plotting Items - Construction Elements, Type 66 Elements, Etc.	4	0 / Continuous	0
	msarsp	NorthArw_dp	North Arrows	0	0 / Continuous	2
X	msarsp	ObjectMarker	Object and Reflective Markers	3	0 / Continuous	1
X	msarsp	OverheadSign	Overhead Sign Panels	0	0 / Continuous	2
X	msarsp	OverheadSign_ep	Overhead Sign Panels (Existing)	0	3 / DGN3	1
X	msarsp	OverheadStr	Mast Arm, Truss Assemblies, Signal Arms and Supports	0	0 / Continuous	2
X	msarsp	OverheadStr_ep	Mast Arm, Truss Assemblies, Signal Arms and Supports (Existing)	0	3 / DGN3	1
	msarsp	PayItem_dp	Pay Item Number Label Elements	4	0 / Continuous	2
X	msarsp	PedDetector	Pedestrian Detector	0	0 / Continuous	2
X	msarsp	Pedestal	Pedestal	1	0 / Continuous	1
X	msarsp	Pedestal_ep	Pedestal (Existing)	1	2 / DGN2	1
X	msarsp	PedHead	Pedestrian Head (All Types)	1	0 / Continuous	1
X	msarsp	PedHead_ep	Pedestrian Head (All Types) (Existing)	0	2 / DGN2	1
X	msarsp	PlotBorder_dp	Plot Border	3	0 / Continuous	0
	msarsp	PointLocator_ep	Point Locator Symbol (Existing)	4	0 / Continuous	0
X	msarsp	PoleConc	Concrete Strain Pole	0	0 / Continuous	2
X	msarsp	PoleConc_ep	Concrete Strain Pole (Existing)	0	2 / DGN2	1
X	msarsp	PoleFound	Pole Foundation	0	0 / Continuous	2
X	msarsp	PoleLight	Light Pole	2	0 / Continuous	1
X	msarsp	PoleLight_ep	Light Pole (Existing)	2	2 / DGN2	1
X	msarsp	PoleLightHM	High Mast Light Pole	3	0 / Continuous	1
X	msarsp	PoleLightHM_ep	High Mast Light Pole (Existing)	2	2 / DGN2	1

Critical	Rule	Level Name	Level Description	ByLevel Color	ByLevelStyle / Linetype	ByLevel Weight
	msarsp	PoleLightID	Light Pole Location / ID	4	0 / Continuous	1
X	msarsp	PullBox	Pull Boxes (All Types)	3	0 / Continuous	1
	msarsp	ReferencePt_dp	Survey and Construction Reference Point Details and Elements	4	0 / Continuous	2
X	msarsp	SawCuts	Saw Cuts	3	3 / DGN3	0
	msarsp	Scale_dp	Bar Scale, Scale Label Elements	0	0 / Continuous	2
	msarsp	Scratch1_dp	Scratch Level for Temporary or Informational Items	4	0 / Continuous	0
	msarsp	Scratch2_dp	Scratch Level for Temporary or Informational Items	5	0 / Continuous	0
	msarsp	ScratchEle_dp	Scratch Level for Draft Elements, Temporary Elements, Etc. (DO NOT PLOT)	3	0 / Continuous	0
	msarsp	ScratchEle2_dp	Scratch Level for Draft Elements, Temporary Elements, Etc. (DO NOT PLOT)	4	0 / Continuous	0
	msarsp	SheetBorder_dp	Sheet Border	1	0 / Continuous	4
	msarsp	SheetLines_dp	Sheet Lines	1	0 / Continuous	2
	msarsp	SheetLinesMisc1_dp	Sheet Lines	1	0 / Continuous	0
	msarsp	SheetLinesMisc2_dp	Sheet Lines	2	0 / Continuous	2
	msarsp	SheetLinesMisc3_dp	Sheet Lines	3	0 / Continuous	2
	msarsp	SheetLinesMisc4_dp	Sheet Lines	4	0 / Continuous	2
X	msarsp	SignalCable	Signal Cable	3	SG-Cable / Continuous	1
X	msarsp	SignalCableAccs	Signal Cable Accessories	0	0 / Continuous	2
X	msarsp	SignalDetail	Signal Details	0	0 / Continuous	1
	msarsp	SignalHead	Signal Head Section Details	2	0 / Continuous	1
X	msarsp	SignalHead_ep	Signal Head Section Details (Existing)	2	2 / DGN2	0
	msarsp	SignalMisc	Signal Equipment (Miscellaneous)	3	0 / Continuous	1
X	msarsp	SignalSOP	S.O.P. Box and Movements	0	0 / Continuous	2
X	msarsp	SignalSym	Signal Head Symbols	0	0 / Continuous	1
X	msarsp	SignalSym_ep	Signal Head Symbols (Existing)	3	2 / DGN2	0
X	msarsp	SignCantilever	Sign Symbol Cantilever	0	0 / Continuous	1
X	msarsp	SignCantilever_ep	Sign Symbol Cantilever (Existing)	0	2 / DGN2	0
	msarsp	SignDetail	Sign Details	0	0 / Continuous	2
	msarsp	SignLettersAZ	Alphabet Cell Library Letter A-Z Numbers 0-9	0	0 / Continuous	0
	msarsp	SignMisc	Sign Symbols (Miscellaneous)	3	0 / Continuous	1
	msarsp	SignMisc_ep	Sign Symbols (Miscellaneous) (Existing)	1	1 / DGN1	1
X	msarsp	SignPanel	Sign Panels - Regulatory	0	0 / Continuous	2
X	msarsp	SignPanel_ep	Sign Panel Elements (Existing)	0	2 / DGN2	1
X	msarsp	SignPanelBorder	Sign Panel Border on Sign Details	0	0 / Continuous	1
X	msarsp	SignSpanwire	Span Wire Signing Assembly	2	0 / Continuous	1
X	msarsp	SignSpanwire_ep	Span Wire Signing Assembly (Existing)	2	2 / DGN2	1
X	msarsp	SignSpecial	Special Signs / Guide Signs	2	0 / Continuous	2
X	msarsp	SignSupport	Ground Mounted Sign Support Symbol (All Types)	1	0 / Continuous	1
X	msarsp	SignSymbol_px	Sign Structure and Foundation on Cross Sections	4	0 / Continuous	2
X	msarsp	SignTruss	Sign Symbol Truss	3	0 / Continuous	1
X	msarsp	SignTruss_ep	Sign Symbol Truss (Existing)	3	2 / DGN2	1
	msarsp	SpecialDetails	Special Details	6	0 / Continuous	1
	msarsp	SumBoxBorder_dp	Summary Boxes Borders	4	0 / Continuous	3
	msarsp	SumBoxLines_dp	Summary Boxes Lines and Miscellaneous Items	4	0 / Continuous	1
	msarsp	SumBoxLinesMin_dp	Summary Boxes Lines Minor Line and Miscellaneous Items	4	0 / Continuous	0
	msarsp	Tables_dp	Data Tables and All Autodesk Tables	0	0 / Continuous	1
	msarsp	TextBLStation	Text - B/L Station and Tics	0	0 / Continuous	2

Critical	Rule	Level Name	Level Description	ByLevel Color	ByLevelStyle / Linetype	ByLevel Weight
	msarsp	TextConstEle	Text - Construction Element	0	0 / Continuous	1
	msarsp	TextCurveData	Text - Curve Data Note	0	0 / Continuous	2
	msarsp	TextDetails	Text - Detail Notes	4	0 / Continuous	2
	msarsp	TextDrainInvElev_ep	Text - Drainage Invert Elevation (Existing)	0	0 / Continuous	1
	msarsp	TextDrainLabel_ep	Text - Drainage (Existing)	0	0 / Continuous	1
	msarsp	TextElevLabel	Text - Elevation Labels	4	0 / Continuous	0
	msarsp	TextLabel	Text - Label	0	0 / Continuous	2
	msarsp	TextLandscape	Text - Landscape Labels	0	0 / Continuous	1
	msarsp	TextMajor	Text - Major	0	0 / Continuous	5
	msarsp	TextMinor	Text - Minor	0	0 / Continuous	0
	msarsp	TextMisc	Text - Miscellaneous	0	0 / Continuous	1
	msarsp	TextNotes	Text - Notes	4	0 / Continuous	1
	msarsp	TextProfLabel	Text - Profile, Horizontal and Vertical Axis Labels	0	0 / Continuous	2
	msarsp	TextProjLabel	Text - Begin and End Project Label with Leader Lines	1	0 / Continuous	2
	msarsp	TextPtLabel	Text - Point Labels	4	0 / Continuous	0
	msarsp	TextShtNo	Text - Sheet Number	0	0 / Continuous	2
	msarsp	TextSubUtilLabel_ep	Text - Subsurface Utilities (Existing)	0	0 / Continuous	1
	msarsp	TextSurveyLabel	Text - Survey Labels	0	0 / Continuous	0
	msarsp	TextTables	Text - Key Sheet Indexes and Table Data	4	0 / Continuous	2
	msarsp	TextTitle	Text - Title	0	0 / Continuous	3
	msarsp	TextTopoLabel_ep	Text - Topography (Existing)	0	0 / Continuous	1
	msarsp	TextUtilLabel_ep	Text - Utilities (Existing)	0	0 / Continuous	1
	msarsp	TextXSElev	Text - Cross Section Elevations	2	0 / Continuous	1
	msarsp	Viewport	Viewport (For AutoCAD Use)	3	0 / Continuous	0
	msarsp	Xreference01_dp	Reference Files (For AutoCAD Use)	0	0 / Continuous	1
	msarsp	Xreference02_dp	Reference Files (For AutoCAD Use)	0	0 / Continuous	1
	msarsp	Xreference03_dp	Reference Files (For AutoCAD Use)	0	0 / Continuous	1
	msarsp	Xreference04_dp	Reference Files (For AutoCAD Use)	0	0 / Continuous	1
	msarsp	XSCell	GEOPAK Cross Section Cell/Block and Profile Cell/Block	8	0 / Continuous	1

## OPEN - All Levels and Symbology Accepted

Critical	Rule	Level Name	Level Description	ByLevel Color	ByLevelStyle / Linetype	ByLevel Weight
	open		<< All Levels and Symbology Accepted >>			

## PDXSRD - Pond Cross Section

Critical	Rule	Level Name	Level Description	ByLevel Color	ByLevelStyle / Linetype	ByLevel Weight
	pdxsrd	ActivePointCell_dp	Active Point Cell	4	0 / Continuous	10
	pdxsrd	AdhocPoint_dp	Adhoc Points Placed by SheetInfo	0	4 / DGN4	0
	pdxsrd	BaselineSurvey	Baseline Survey	0	0 / Continuous	2
X	pdxsrd	Berm_px	Berm (Top, Front, or Back) on Cross Sections	10	0 / Continuous	2

Critical	Rule	Level Name	Level Description	ByLevel Color	ByLevelStyle / Linetype	ByLevel Weight
X	pdxsrd	Bridge_px	Bridge Component on Cross Sections - Component Property	0	0 / Continuous	2
X	pdxsrd	CandG_ex	Curb and Gutter on Cross Sections (All Types) (Existing)	4	2 / DGN2	1
X	pdxsrd	CandG_px	Curb and Gutter on Cross Sections (All Types)	4	0 / Continuous	2
X	pdxsrd	CandGBase_px	Curb and Gutter Base on Cross Sections	3	0 / Continuous	1
X	pdxsrd	CATVBur_ex	Cable TV and Miscellaneous on Cross Sections (Buried) (Existing)	6	2 / DGN2	1
X	pdxsrd	CATVBur_px	Cable TV and Miscellaneous on Cross Sections (Buried)	6	0 / Continuous	1
	pdxsrd	CLConst_dp	Center Line of Construction	0	0 / Continuous	2
	pdxsrd	Cloud_dp	Construction Cloud	7	0 / Continuous	2
	pdxsrd	COGO_dp	COGO Information	3	0 / Continuous	1
X	pdxsrd	Concrete_px	Concrete Boundary Lines on Cross Sections	0	0 / Continuous	2
X	pdxsrd	Conduit_ex	Conduit and Encasements on Cross Sections (Existing)	3	2 / DGN2	1
X	pdxsrd	Conduit_px	Conduit and Encasements on Cross Sections	3	0 / Continuous	1
	pdxsrd	ConstArea_dp	Construction Area Crosshatch	0	0 / Continuous	1
	pdxsrd	ConstLimits	Construction Limits	3	RW-LimitsofConst	2
	pdxsrd	ConstLines	Construction Lines and References	1	0 / Continuous	0
	pdxsrd	ConstLines_pm	Construction Lines	4	0 / Continuous	0
	pdxsrd	CurveData_dp	Curve and Coordinate Data Elements Including PC, PT, PI Symbols	4	0 / Continuous	2
	pdxsrd	CurveDataLabel_dp	Curve Data Labels PC,PI, PT	0	0 / Continuous	2
	pdxsrd	DimLines_dp	Dimension Lines, Corresponding Terminators, Equation Lines	0	0 / Continuous	1
X	pdxsrd	Ditch_px	Ditch Top on Cross Sections	7	0 / Continuous	2
X	pdxsrd	DitchBot_px	Ditch Bottom on Cross Sections	10	0 / Continuous	2
X	pdxsrd	DitchPavt_px	Ditch Pavement on Cross Sections	3	0 / Continuous	3
	pdxsrd	DrainAlert_px	Alert Symbolology for Structural Elements on Cross Sections	3	0 / Continuous	2
	pdxsrd	DrainMisc_ex	Drainage Elements on Cross Sections (All) (Miscellaneous) (Existing)	10	3 / DGN3	1
X	pdxsrd	DrainStruct_ex	Drainage Structures on Cross Sections (All) (Existing)	10	3 / DGN3	1
X	pdxsrd	DrainStruct_px	Drainage Structures and Elements for on Cross Sections (Miscellaneous)	10	0 / Continuous	2
X	pdxsrd	Driveway_ex	Driveway Lines on Cross Sections (Existing)	7	2 / DGN2	2
X	pdxsrd	Driveway_px	Driveway Lines on Cross Sections	7	0 / Continuous	2
X	pdxsrd	DrivewayBase_px	Driveway SubgradeSubgrade on Cross Sections	3	0 / Continuous	2
	pdxsrd	Earthwork1_px	Earthwork (Color 0) on Cross Sections	0	0 / Continuous	1
	pdxsrd	Earthwork2_px	Earthwork (Color 1) on Cross Sections	1	0 / Continuous	1
	pdxsrd	Earthwork3_px	Earthwork (Color 2) on Cross Sections	2	0 / Continuous	1
	pdxsrd	Earthwork4_px	Earthwork (Color 3) on Cross Sections	3	0 / Continuous	1
	pdxsrd	Earthwork5_px	Earthwork (Color 4) on Cross Sections	4	0 / Continuous	1
X	pdxsrd	EaseLicLine	Easement License Agreement Line	5	6 / DGN2	0
X	pdxsrd	EaseLine_ep	Easement Lines (Existing)	1	RW-Easement	1
X	pdxsrd	EasePerpLine_px	Easement Lines Perpetual on Cross Sections	4	RW-PerpetualEasement	12
X	pdxsrd	EaseTempLine_px	Easement Lines Temporary on Cross Sections	6	RW-TemporaryEasement	0
X	pdxsrd	ElecBur_ex	Electrical on Cross Sections (Buried) (Existing)	3	2 / DGN2	1
X	pdxsrd	ElecBur_px	Electrical on Cross Sections (Buried)	3	0 / Continuous	1
X	pdxsrd	Endwall_px	Endwall on Cross Sections	10	0 / Continuous	2
	pdxsrd	ExcavationLimits_dp	Excavation Limits on Cross Sections	0	0 / Continuous	1
	pdxsrd	Fence_ex	Fence Lines on Cross Sections (Existing)	6	3 / DGN3	1
X	pdxsrd	Fence_px	Fence Lines on Cross Sections	6	RD-Fence	2
X	pdxsrd	FES_px	Flared End Sections on Cross Sections	10	0 / Continuous	2
X	pdxsrd	FOCBur_ex	Fiber Optics Cable on Cross Sections (Buried) (Existing)	6	2 / DGN2	1

Critical	Rule	Level Name	Level Description	ByLevel Color	ByLevelStyle / Linetype	ByLevel Weight
X	pdxsrd	FOCBur_px	Fiber Optics Cable on Cross Sections (Buried)	6	0 / Continuous	1
X	pdxsrd	FOEElecBur_ex	Fiber Optics Electrical on Cross Sections (Buried) (Existing)	3	2 / DGN2	1
X	pdxsrd	FOEElecBur_px	Fiber Optics Electrical on Cross Sections (Buried)	3	0 / Continuous	1
X	pdxsrd	FOTBur_ex	Fiber Optics Telephone on Cross Sections (Buried) (Existing)	6	2 / DGN2	1
X	pdxsrd	FOTBur_px	Fiber Optics Telephone on Cross Sections (Buried)	6	0 / Continuous	1
X	pdxsrd	Gas_ex	Gas Pipe and Fittings on Cross Sections (Miscellaneous) (Existing)	4	2 / DGN2	1
X	pdxsrd	Gas_px	Gas Pipe and Fittings on Cross Sections (Miscellaneous)	4	0 / Continuous	1
	pdxsrd	GeotechFillPatt1	Geotechnical Fill Pattern - (Earth, Wood, Muck, Concrete, Rock, Riprap) as Defined in Project	3	0 / Continuous	0
	pdxsrd	GeotechFillPatt1_px	Geotechnical Fill Pattern on Cross Sections - (Earth, Wood, Muck, Concrete, Rock, Riprap) as Defined in Project	3	0 / Continuous	0
	pdxsrd	GeotechFillPatt2	Geotechnical Fill Pattern - Clay, Sand	0	1 / DGN1	0
	pdxsrd	GeotechFillPatt2_px	Geotechnical Fill Pattern on Cross Sections - Clay, Sand	0	1 / DGN1	0
	pdxsrd	GeotechFillPatt3	Geotechnical Fill Pattern - Shell	3	1 / DGN1	0
	pdxsrd	GeotechFillPatt3_px	Geotechnical Fill Pattern on Cross Sections - Shell	3	1 / DGN1	0
	pdxsrd	GeotechFillPatt4	Geotechnical Fill Pattern - Sand	4	0 / Continuous	0
	pdxsrd	GeotechFillPatt4_px	Geotechnical Fill Pattern on Cross Sections - Sand	4	0 / Continuous	0
	pdxsrd	GeotechFillPatt5	Geotechnical Fill Pattern - Coquina	1	0 / Continuous	1
	pdxsrd	GeotechFillPatt5_px	Geotechnical Fill Pattern on Cross Sections - Coquina	1	0 / Continuous	1
	pdxsrd	GeotechFillPatt6	Geotechnical Fill Pattern - Limestone	2	0 / Continuous	0
	pdxsrd	GeotechFillPatt6_px	Geotechnical Fill Pattern on Cross Sections - Limestone	2	0 / Continuous	0
	pdxsrd	GeotechFillPatt7	Geotechnical Fill Pattern - Gravel	6	0 / Continuous	0
	pdxsrd	GeotechFillPatt7_px	Geotechnical Fill Pattern on Cross Sections - Gravel	6	0 / Continuous	0
	pdxsrd	GeotechFillPatt8	Geotechnical Fill Pattern - Silt	0	0 / Continuous	1
	pdxsrd	GeotechFillPatt8_px	Geotechnical Fill Pattern on Cross Sections - Silt	0	0 / Continuous	1
	pdxsrd	GeotechMisc	Geotechnical Elements (Miscellaneous)	0	0 / Continuous	1
	pdxsrd	GPKDrBack_dp	Back Point on Drainage Cells	2	2 / DGN2	2
	pdxsrd	GPKDrBottom_dp	Bottom Point on Drainage Cells	3	3 / DGN3	2
	pdxsrd	GPKDrCellIns_dp	Cell Insertion Point on Drainage Cells	4	4 / DGN5	2
	pdxsrd	GPKDrCentroid_dp	Point on Centroid for Drainage	7	7 / DGN7	2
	pdxsrd	GPKDrElv	Location Point for Drainage Cells	5	5 / DGN5	2
	pdxsrd	GPKDrFront_dp	Front Point on Drainage Cells	1	1 / DGN1	2
	pdxsrd	GPKDrPipe_dp	Point on Drainage Pipe	6	6 / DGN6	2
	pdxsrd	GPKDrPipeCir_dp	Point on Pipe Circular	6	6 / DGN6	0
	pdxsrd	GridMaj_dp	Grid Lines Major in Profile and Cross Section	3	0 / Continuous	1
	pdxsrd	GridMin_dp	Grid Lines Minor in Profile and Cross Section	0	0 / Continuous	0
	pdxsrd	GridMinG_dp	Grid Lines Minor Sub 2 on Cross Section Sheets	20	0 / Continuous	0
	pdxsrd	GridMinSub_dp	Grid Lines Minor Sub on Cross Section Sheets	20	0 / Continuous	0
X	pdxsrd	Guardrail_ex	Guardrail Lines on Cross Sections (Existing)	0	2 / DGN2	2
X	pdxsrd	GuardrailPanel_px	Guardrail Component Property on Cross Sections for 3D Guardrail Panels	11	0 / Continuous	1
X	pdxsrd	GuardrailPost_px	Guardrail Component Property on Cross Sections for 3D Guardrail Posts	10	0 / Continuous	0
	pdxsrd	ImageAttachment_dp	Image Attachments	0	0 / Continuous	0
X	pdxsrd	Inlet_px	Inlets on Cross Sections	10	0 / Continuous	2
X	pdxsrd	InletBottom_px	Inlet Bottom on Cross Sections (All Types)	10	0 / Continuous	2
	pdxsrd	KeyShtMisc	Key Sheet Items (Miscellaneous)	0	0 / Continuous	2
X	pdxsrd	LARWLine_ex	Limited Access Right of Way Lines on Cross Sections (Existing)	4	RW-LimitedAccess-Existing	1
X	pdxsrd	LARWLine_px	Limited Access Right of Way Lines on Cross Sections	4	RW-LimitedAccess-Proposed	2
X	pdxsrd	LateralLimits_px	Lateral Limits on Cross Sections	6	0 / Continuous	2



Critical	Rule	Level Name	Level Description	ByLevel Color	ByLevelStyle / Linetype	Bylevel Weight
	pdxsrd	LeaderLine_dp	Leader Line and Terminator with Text	0	0 / Continuous	1
	pdxsrd	Logo_dp	Consultant Engineer of Record Logo	0	0 / Continuous	1
	pdxsrd	Manhole_ex	Manhole on Cross Sections (Existing)	10	3 / DGN3	2
X	pdxsrd	Manhole_px	Manhole on Cross Sections	10	0 / Continuous	2
X	pdxsrd	MES_px	Mitered End Section on Cross Sections	10	0 / Continuous	2
	pdxsrd	Miscellaneous0	Undefined Proposed Item - Color Blue Weight 0	1	0 / Continuous	0
	pdxsrd	Miscellaneous1	Undefined Proposed Item - Color Blue Weight 1	1	0 / Continuous	1
	pdxsrd	Miscellaneous2	Undefined Proposed Item - Color Blue Weight 2	1	0 / Continuous	2
	pdxsrd	Miscellaneous3	Undefined Proposed Item - Color Green Weight 0	2	0 / Continuous	0
	pdxsrd	Miscellaneous4	Undefined Proposed Item - Color Green Weight 1	2	0 / Continuous	1
	pdxsrd	Miscellaneous5	Undefined Proposed Item - Color Green Weight 2	2	0 / Continuous	2
	pdxsrd	Miscellaneous6	Undefined Proposed Item - Color Red Weight 0	3	0 / Continuous	0
	pdxsrd	Miscellaneous7	Undefined Proposed Item - Color Red Weight 1	3	0 / Continuous	1
	pdxsrd	Miscellaneous8	Undefined Proposed Item - Color Red Weight 2	3	0 / Continuous	2
	pdxsrd	Miscellaneous9	Undefined Proposed Item - Color Red Weight 3	3	0 / Continuous	3
	pdxsrd	NonPlottingEle_dp	Non-Plotting Items - Construction Elements, Type 66 Elements, Etc.	4	0 / Continuous	0
	pdxsrd	Patternlines_ep	Cross Section Chain (Existing)	2	1 / DGN1	0
	pdxsrd	PatternLines1_dp	Pattern Lines on Cross Sections and All Autodesk (Civil 3D) Tables	3	0 / Continuous	2
	pdxsrd	PatternLines2_dp	Pattern Lines on Cross Sections Alternate for Side Streets, CriticalCross Sections or Drainage Structures	4	0 / Continuous	2
	pdxsrd	PatternLines3_dp	Pattern Lines on Cross Sections Alternate for Side Streets, CriticalCross Sections or Drainage Structures	5	0 / Continuous	2
X	pdxsrd	PavedMedianBase_px	Median Subgrade on Cross Sections (Paved)	3	0 / Continuous	2
	pdxsrd	PavtAsphalt_ep	Asphalt Pavement Edge (Existing)	0	3 / DGN3	1
X	pdxsrd	PavtAsphalt_px	Asphalt Pavement on Cross Sections and Components in Models	1	0 / Continuous	2
X	pdxsrd	PavtBase_ex	Base Material on Cross Sections (All Types) (Existing)	3	3 / DGN3	1
X	pdxsrd	PavtBase_px	Base Material on Cross Sections (All Types)	3	0 / Continuous	2
X	pdxsrd	PavtConcrete_px	Concrete Pavement on Cross Sections and Components in Models	0	0 / Continuous	2
X	pdxsrd	PavtMilling_px	Asphalt Milling Lines on Cross Sections	7	0 / Continuous	2
X	pdxsrd	PavtMisc_px	Pavement on Cross Sections (Miscellaneous)	1	0 / Continuous	2
X	pdxsrd	PavtOverbuild_px	Pavement Overbuild Areas on Cross Sections - Component Property	4	0 / Continuous	2
X	pdxsrd	PavtOverlay_px	Pavement Overlay on Cross Sections - Component Property	1	0 / Continuous	2
X	pdxsrd	PavtOverlay1_px	Pavement Overlay on Cross Sections - Component Property	14	0 / Continuous	2
X	pdxsrd	PavtOverlay2_px	Pavement Overlay on Cross Sections - Component Property	7	0 / Continuous	2
X	pdxsrd	PavtStabilization_px	Stabilization on Cross Sections	5	2 / DGN2	2
	pdxsrd	Paytem_dp	Pay Item Number Label Elements	4	0 / Continuous	2
	pdxsrd	PipeCulvert_ep	Pipe Culvert (Existing)	10	3 / DGN3	1
X	pdxsrd	PipeCulvert_ex	Pipe Culvert in Cross Sections (Existing)	10	3 / DGN3	1
X	pdxsrd	PipeCulvert_pr	Pipe Culvert in Profile	10	0 / Continuous	2
X	pdxsrd	PipeCulvert_px	Pipe Culvert on Cross Section View	10	0 / Continuous	2
X	pdxsrd	PlotBorder_dp	Plot Border	3	0 / Continuous	0
	pdxsrd	PointLocator_ep	Point Locator Symbol (Existing)	4	0 / Continuous	0
X	pdxsrd	Pond_px	Pond Lines on Cross Sections	2	0 / Continuous	2
X	pdxsrd	PropertyLine_ep	Property Lines (Existing)	3	0 / Continuous	0
X	pdxsrd	PvtAnalysisCrown_px	Pavement Analysis Crowning on Cross Sections - Component Property	7	0 / Continuous	1
X	pdxsrd	PvtAnalysisFail_px	Pavement Analysis Failure on Cross Sections - Component Property	3	0 / Continuous	1
X	pdxsrd	PvtAnalysisMax_px	Pavement Analysis Acceptable Maximum Range on Cross Sections - Component Property	5	0 / Continuous	1

Critical	Rule	Level Name	Level Description	ByLevel Color	ByLevelStyle / Linetype	ByLevel Weight
X	pdxsrd	PvtAnalysisMin_px	Pavement Analysis Acceptable Minimum Range on Cross Sections - Component Property	4	0 / Continuous	1
X	pdxsrd	PvtAnalysisOptiml_px	Pavement Analysis Optima on Cross Sections I - Component Property	2	0 / Continuous	1
X	pdxsrd	Railing_px	Railing Components and Cross Sections Shapes	9	0 / Continuous	2
	pdxsrd	ReferencePt_dp	Survey and Construction Reference Point Details and Elements	4	0 / Continuous	2
	pdxsrd	RegionBdry_dp	Boundary Line for Regions in Corridor Design (For AutoCAD Use)	0	0 / Continuous	0
X	pdxsrd	RipRap_px	Rip Rap, Rubble on Cross Sections	4	1 / DGN1	2
X	pdxsrd	RumbleStrip1	Rumble Strips Continuous Array	0	PM-RumbleSolid	2
X	pdxsrd	RumbleStrip2	Rumble Strips Skip Array	0	PM-RumbleSkip	2
X	pdxsrd	RWLine	Right of Way Lines	4	RW-Proposed	2
X	pdxsrd	RWLine_ep	Right of Way Lines (Existing)	3	RW-Existing	1
X	pdxsrd	RWLine_ex	Right of Way Lines on Cross Sections (Existing)	3	RW-Existing	1
X	pdxsrd	RWLine_px	Right of Way Lines on Cross Sections	4	RW-Proposed	2
X	pdxsrd	SanitaryFM_ex	Force Main Lines on Cross Sections (Existing)	2	2 / DGN2	1
X	pdxsrd	SanitaryFM_px	Force Main Lines on Cross Sections	2	0 / Continuous	1
X	pdxsrd	SanitarySewer_ex	Sanitary Sewer on Cross Sections (Existing)	2	2 / DGN2	0
X	pdxsrd	SanitarySewer_px	Sanitary Sewer on Cross Sections	2	0 / Continuous	1
X	pdxsrd	SanitarySewerEff_ex	Sanitary Sewer Effluent on Cross Sections (Existing)	5	0 / Continuous	0
X	pdxsrd	SanitarySewerEff_px	Sanitary Sewer Effluent on Cross Sections	5	0 / Continuous	0
	pdxsrd	Scratch1_dp	Scratch Level for Temporary or Informational Items	4	0 / Continuous	0
	pdxsrd	Scratch2_dp	Scratch Level for Temporary or Informational Items	5	0 / Continuous	0
	pdxsrd	ScratchEle_dp	Scratch Level for Draft Elements, Temporary Elements, Etc. (DO NOT PLOT)	3	0 / Continuous	0
	pdxsrd	ScratchEle2_dp	Scratch Level for Draft Elements, Temporary Elements, Etc. (DO NOT PLOT)	4	0 / Continuous	0
	pdxsrd	SheetBorder_dp	Sheet Border	1	0 / Continuous	4
	pdxsrd	SheetLines_dp	Sheet Lines	1	0 / Continuous	2
	pdxsrd	SheetLinesMisc1_dp	Sheet Lines	1	0 / Continuous	0
	pdxsrd	SheetLinesMisc2_dp	Sheet Lines	2	0 / Continuous	2
	pdxsrd	SheetLinesMisc3_dp	Sheet Lines	3	0 / Continuous	2
	pdxsrd	SheetLinesMisc4_dp	Sheet Lines	4	0 / Continuous	2
X	pdxsrd	ShldrBase_px	Shoulder Base on Cross Sections	3	0 / Continuous	2
X	pdxsrd	ShldrMilling_px	Shoulder Milling on Cross Sections - Component Property	7	0 / Continuous	2
X	pdxsrd	ShldrOverbuild_px	Shoulder Overbuild on Cross Sections - Component Property	4	0 / Continuous	1
X	pdxsrd	ShldrOverlay_px	Shoulder Overlay on Cross Sections - Component Property	1	0 / Continuous	1
X	pdxsrd	ShldrPaved_px	Shoulder Lines on Cross Sections (Paved)	1	0 / Continuous	2
X	pdxsrd	ShldrUnpaved_px	Shoulder Lines on Cross Sections (Unpaved)	2	0 / Continuous	2
X	pdxsrd	Sidewalk_ex	Sidewalk Elements on Cross Sections (Existing)	0	2 / DGN2	1
X	pdxsrd	Sidewalk_px	Sidewalk Elements on Cross Sections	0	0 / Continuous	2
	pdxsrd	SidewalkBack_er	Back of Sidewalk Line Profile (Existing)	2	2 / DGN2	1
	pdxsrd	SidewalkBack_pr	Back of Sidewalk Line Profile	5	0 / Continuous	2
X	pdxsrd	SidewalkBase_px	Sidewalk Subgrade on Cross Sections	3	0 / Continuous	2
X	pdxsrd	Slopes_px	Slope Lines on Cross Sections	9	0 / Continuous	2
X	pdxsrd	SoilBoxes_px	Soil Boxes and Borings on Cross Sections	4	0 / Continuous	1
	pdxsrd	SpecialDetails_px	Special Details on Cross Sections	6	0 / Continuous	1
	pdxsrd	StationTicL_dp	Station Tic Marks (Large) and Text	0	0 / Continuous	2
	pdxsrd	StationTicS_dp	Station Tic Marks (Small) and Text	0	0 / Continuous	2
X	pdxsrd	StreetLights_px	Street Lights on Cross Sections	3	0 / Continuous	1
	pdxsrd	Structure_px	Signal and Sign Structures on Cross Sections	0	0 / Continuous	2



Critical	Rule	Level Name	Level Description	ByLevel Color	ByLevelStyle / Linetype	ByLevel Weight
X	pdxsr	SubDsgn_px	Sub Design on Cross Sections including sub-base	4	0 / Continuous	1
X	pdxsr	Subsoil_px	Subsoil Or Undercut on Cross Sections	4	0 / Continuous	2
X	pdxsr	SubsoilFinal_px	Subsoil Final for Multiline on Cross Sections	18	0 / Continuous	1
X	pdxsr	SubsoilProp_px	Subsoil Proposed for Multiline on Cross Sections	8	0 / Continuous	1
	pdxsr	SumBoxBorder_dp	Summary Boxes Borders	4	0 / Continuous	3
	pdxsr	SumBoxLines_dp	Summary Boxes Lines and Miscellaneous Items	4	0 / Continuous	1
	pdxsr	SumBoxLinesMin_dp	Summary Boxes Lines Minor Line and Miscellaneous Items	4	0 / Continuous	0
	pdxsr	Tables_dp	Data Tables and All Autodesk Tables	0	0 / Continuous	1
X	pdxsr	TeleBur_ex	Telephone on Cross Sections (Buried) (Miscellaneous) (Existing)	6	2 / DGN2	1
X	pdxsr	TeleBur_px	Telephone on Cross Sections (Buried) (Miscellaneous)	6	0 / Continuous	1
X	pdxsr	TemplateBottom_px	Bottom of Template for Multiline on Cross Sections	6	0 / Continuous	1
X	pdxsr	TemplateFinal_px	Final Template for Multiline on Cross Sections	2	0 / Continuous	1
X	pdxsr	TemplateTop_px	Top of Template for Multiline on Cross Sections	7	0 / Continuous	1
X	pdxsr	TerrainLine_ex	Ground Line for Multiline on Cross Sections (Existing)	5	0 / Continuous	1
	pdxsr	TextAlert	Text - Alert Label to Highlight a Problem	3	0 / Continuous	2
	pdxsr	TextBLStation	Text - B/L Station and Tics	0	0 / Continuous	2
	pdxsr	TextConstEle	Text - Construction Element	0	0 / Continuous	1
	pdxsr	TextCurveData	Text - Curve Data Note	0	0 / Continuous	2
	pdxsr	TextDetails	Text - Detail Notes	4	0 / Continuous	2
	pdxsr	TextDrainInvElev_ep	Text - Drainage Invert Elevation (Existing)	0	0 / Continuous	1
	pdxsr	TextDrainLabel_ep	Text - Drainage (Existing)	0	0 / Continuous	1
	pdxsr	TextElevLabel	Text - Elevation Labels	4	0 / Continuous	0
	pdxsr	TextGeotech	Text - Soil Borings and Labels	0	0 / Continuous	2
	pdxsr	TextLabel	Text - Label	0	0 / Continuous	2
	pdxsr	TextLandscape	Text - Landscape Labels	0	0 / Continuous	1
	pdxsr	TextMajor	Text - Major	0	0 / Continuous	5
	pdxsr	TextMinor	Text - Minor	0	0 / Continuous	0
	pdxsr	TextMisc	Text - Miscellaneous	0	0 / Continuous	1
	pdxsr	TextNotes	Text - Notes	4	0 / Continuous	1
	pdxsr	TextProfLabel	Text - Profile, Horizontal and Vertical Axis Labels	0	0 / Continuous	2
	pdxsr	TextProjLabel	Text - Begin and End Project Label with Leader Lines	1	0 / Continuous	2
	pdxsr	TextPtLabel	Text - Point Labels	4	0 / Continuous	0
	pdxsr	TextShtNo	Text - Sheet Number	0	0 / Continuous	2
	pdxsr	TextSubUtilLabel_ep	Text - Subsurface Utilities (Existing)	0	0 / Continuous	1
	pdxsr	TextSurveyLabel	Text - Survey Labels	0	0 / Continuous	0
	pdxsr	TextTables	Text - Key Sheet Indexes and Table Data	4	0 / Continuous	2
	pdxsr	TextTitle	Text - Title	0	0 / Continuous	3
	pdxsr	TextTopoLabel_ep	Text - Topography (Existing)	0	0 / Continuous	1
	pdxsr	TextUtilLabel_ep	Text - Utilities (Existing)	0	0 / Continuous	1
	pdxsr	TextXSBL_dp	Text - Cross Section Baseline Labels	0	0 / Continuous	2
	pdxsr	TextXSDrain_ex	Text - Cross Section Drainage Labels (Existing)	10	0 / Continuous	2
	pdxsr	TextXSDrain_px	Text - Cross Section Drainage Labels	10	0 / Continuous	2
	pdxsr	TextXSElev	Text - Cross Section Elevations	2	0 / Continuous	1
	pdxsr	TextXSElev_ex	Text - Cross Section Elevations (Existing)	2	0 / Continuous	1
	pdxsr	TextXSElev_px	Text - Cross Section Elevations	0	0 / Continuous	1
	pdxsr	TextXSGPKPts_dp	Text - Cross Section Points Labels	4	0 / Continuous	0

Critical	Rule	Level Name	Level Description	ByLevel Color	ByLevelStyle / Linetype	ByLevel Weight
	pdxsrd	TextXSNotes_dp	Text - Cross Section Notes	0	0 / Continuous	2
	pdxsrd	TextXSSlope_dp	Text - Cross Section Slope Labels (rise:run format)	0	0 / Continuous	2
	pdxsrd	TextXSSlopePvt_dp	Text - Cross Section Pavement Slope Labels	0	0 / Continuous	2
X	pdxsrd	TrafSeparator_ex	Traffic Separator on Cross Sections (All Types) (Existing)	6	2 / DGN2	1
X	pdxsrd	TrafSeparator_px	Traffic Separator on Cross Sections (All Types)	6	0 / Continuous	2
X	pdxsrd	TrafSeparatorBase_px	Traffic Separator Subgrade on Cross Sections	3	0 / Continuous	2
	pdxsrd	TypicalMisc	Typical Items (Miscellaneous)	0	0 / Continuous	2
	pdxsrd	UtilsMisc_ex	Utility Items on Cross Sections (Miscellaneous) (Existing)	8	2 / DGN2	1
	pdxsrd	UtilsMisc_px	Utility Items on Cross Sections (Miscellaneous)	8	0 / Continuous	1
	pdxsrd	Vehicle	Vehicle for Calculating Turning Radius	7	0 / Continuous	2
	pdxsrd	Viewport	Viewport (For AutoCAD Use)	3	0 / Continuous	0
	pdxsrd	VoidArea_dx	Void Area on Cross Sections	1	0 / Continuous	0
X	pdxsrd	WallBarrier_ex	Barrier Wall on Cross Section (Existing)	6	3 / DGN3	1
X	pdxsrd	WallBarrier_px	Barrier Wall on Cross Section	6	0 / Continuous	2
	pdxsrd	WallFooter_px	Wall Footer (Concrete) on Cross Sections - Component Symbology/Material on All Wall Footers/Leveling Pads	2	0 / Continuous	1
X	pdxsrd	WallGravBase_px	Gravity Wall Subgrade on Cross Sections	3	0 / Continuous	2
X	pdxsrd	WallGravity_px	Gravity Wall on Cross Sections	11	0 / Continuous	2
X	pdxsrd	WallMedianBase_px	Median Wall Subgrade on Cross Sections	3	0 / Continuous	2
X	pdxsrd	WallRetain_px	Retaining Walls on Cross Sections	6	0 / Continuous	1
X	pdxsrd	WallShldrBase_px	Shoulder Wall Subgrade on Cross Sections	3	0 / Continuous	2
X	pdxsrd	Water_ex	Water on Cross Sections (Existing)	1	2 / DGN2	1
X	pdxsrd	Water_px	Water on Cross Sections	1	0 / Continuous	1
X	pdxsrd	WaterNP_ex	Raw Water Pipes on Cross Sections (Existing)	5	0 / Continuous	1
X	pdxsrd	WaterNP_px	Raw Water Pipes on Cross Sections	5	0 / Continuous	1
	pdxsrd	Wetland_ex	Wetland Boundary on Cross Sections (Existing)	2	RD-Wetland-Existing	1
	pdxsrd	WetlandEdge_ep	Edge of Mangrove, Wetlands (Marsh or Swamp) (Existing)	2	RD-Wetland-Existing	0
	pdxsrd	Xreference01_dp	Reference Files (For AutoCAD Use)	0	0 / Continuous	1
	pdxsrd	Xreference02_dp	Reference Files (For AutoCAD Use)	0	0 / Continuous	1
	pdxsrd	Xreference03_dp	Reference Files (For AutoCAD Use)	0	0 / Continuous	1
	pdxsrd	Xreference04_dp	Reference Files (For AutoCAD Use)	0	0 / Continuous	1
X	pdxsrd	XSBaseTop_px	Cross Section Top of Base	3	0 / Continuous	2
	pdxsrd	XSCell	GEOPAK Cross Section Cell/Block and Profile Cell/Block	8	0 / Continuous	1
X	pdxsrd	XSExtendGrdLine_ex	Cross Section Extend Ground Lines (Existing)	21	2 / DGN2	1
X	pdxsrd	XSGrdLine_ex	Cross Section Ground Lines (Existing)	2	2 / DGN2	1
X	pdxsrd	XSGrdLine_px	Cross Section Roadway Ground Lines	1	0 / Continuous	2
	pdxsrd	XSMisc_ex	Cross Section Roadway Items (Miscellaneous) (Existing)	4	3 / DGN3	1
	pdxsrd	XSMisc_px	Cross Section Items (Miscellaneous)	0	0 / Continuous	2
	pdxsrd	XSPt_ep	Cross Section Point, Station (Existing)	2	1 / DGN1	0
	pdxsrd	XSShapeDep01_dp	Cross Section Shape Dependent	11	0 / Continuous	2
	pdxsrd	XSShapeDep02_dp	Cross Section Shape Dependent	12	0 / Continuous	2
	pdxsrd	XSShapeDep03_dp	Cross Section Shape Dependent	13	0 / Continuous	2
	pdxsrd	XSShapeDep04_dp	Cross Section Shape Dependent	14	0 / Continuous	2
	pdxsrd	XSShapeDep05_dp	Cross Section Shape Dependent	15	0 / Continuous	2

Critical	Rule	Level Name	Level Description	ByLevel Color	ByLevelStyle / Linetype	ByLevel Weight
	pdxsr	XSShapeDep06_dp	Cross Section Shape Dependent	16	0 / Continuous	2
	pdxsr	XSShapeDep07_dp	Cross Section Shape Dependent	17	0 / Continuous	2
	pdxsr	XSShapeDep08_dp	Cross Section Shape Dependent	18	0 / Continuous	2
	pdxsr	XSShapeDep09_dp	Cross Section Shape Dependent	19	0 / Continuous	2
	pdxsr	XSShapeDep10_dp	Cross Section Shape Dependent	20	0 / Continuous	2
	pdxsr	XSShapeIndep01_dp	Cross Section Shape Independent	1	0 / Continuous	2
	pdxsr	XSShapeIndep02_dp	Cross Section Shape Independent	2	0 / Continuous	2
	pdxsr	XSShapeIndep03_dp	Cross Section Shape Independent	3	0 / Continuous	2
	pdxsr	XSShapeIndep04_dp	Cross Section Shape Independent	4	0 / Continuous	2
	pdxsr	XSShapeIndep05_dp	Cross Section Shape Independent	5	0 / Continuous	2
	pdxsr	XSShapeIndep06_dp	Cross Section Shape Independent	6	0 / Continuous	2
	pdxsr	XSShapeIndep07_dp	Cross Section Shape Independent	7	0 / Continuous	2
	pdxsr	XSShapeIndep08_dp	Cross Section Shape Independent	8	0 / Continuous	2
	pdxsr	XSShapeIndep09_dp	Cross Section Shape Independent	9	0 / Continuous	2
	pdxsr	XSShapeIndep10_dp	Cross Section Shape Independent	10	0 / Continuous	2
X	pdxsr	XSTypical_px	Cross Section Roadway Pavement Typical	1	0 / Continuous	2

## PLANRD - Roadway Plan Sheet

Critical	Rule	Level Name	Level Description	ByLevel Color	ByLevelStyle / Linetype	ByLevel Weight
	planrd	ActivePointCell_dp	Active Point Cell	4	0 / Continuous	10
	planrd	AdhocPoint_dp	Adhoc Points Placed by SheetInfo	0	4 / DGN4	0
	planrd	BaselineSurvey	Baseline Survey	0	0 / Continuous	2
	planrd	CLConst_dp	Center Line of Construction	0	0 / Continuous	2
	planrd	ClipBorder_dp	CLIP Border and Civil 3D View Frame	3	0 / Continuous	0
	planrd	ClipDrawingBound_dp	CLIP Drawing Boundary	3	3 / DGN3	0
	planrd	Cloud_dp	Construction Cloud	7	0 / Continuous	2
	planrd	COGO_dp	COGO Information	3	0 / Continuous	1
	planrd	ConstArea_dp	Construction Area Crosshatch	0	0 / Continuous	1
	planrd	ConstLimits	Construction Limits	3	RW-LimitsofConst	2
	planrd	ConstLines	Construction Lines and References	1	0 / Continuous	0
	planrd	ConstLines_pm	Construction Lines	4	0 / Continuous	0
	planrd	CurveData_dp	Curve and Coordinate Data Elements Including PC, PT, PI Symbols	4	0 / Continuous	2
	planrd	CurveDataLabel_dp	Curve Data Labels PC,PI, PT	0	0 / Continuous	2
	planrd	DimLines_dp	Dimension Lines, Corresponding Terminators, Equation Lines	0	0 / Continuous	1
X	planrd	EaseLicLine	Easement License Agreement Line	5	6 / DGN6	0
	planrd	FLMap1	Florida Map items - Weight of 1	1	0 / Continuous	1
	planrd	FLMap2	Florida Map items - Weight of 2	3	0 / Continuous	2
	planrd	FLMap3	Florida Map items - Weight of 3	2	0 / Continuous	3
	planrd	FLMap4	Florida Map items - Color 11 (Interstate)	11	0 / Continuous	3
	planrd	FLMap5	Florida Map items - Style 7, Weight. 5 (State Line)	3	7 / DGN7	5
	planrd	GradeLine_er	Grade Line Profile (Existing)	2	2 / DGN2	1
	planrd	GradeLine_pr	Grade Line Profile	5	0 / Continuous	2

Critical	Rule	Level Name	Level Description	ByLevel Color	ByLevelStyle / Linetype	ByLevel Weight
	planrd	GradeLineCtr_dp	Grade Line Profile Center (Shown in Plan View)	5	0 / Continuous	0
	planrd	GradeLineCtr_pr	Grade Line Profile Center	5	0 / Continuous	2
	planrd	GradeLineLt_dp	Grade Line Profile Left (Shown in Plan View)	1	0 / Continuous	0
	planrd	GradeLineLt_er	Grade Line Profile Left (Existing)	1	2 / DGN2	1
	planrd	GradeLineLt_pr	Grade Line Profile Left	1	0 / Continuous	2
	planrd	GradeLineRt_dp	Grade Line Profile Right (Shown in Plan View)	4	0 / Continuous	0
	planrd	GradeLineRt_er	Grade Line Profile Right (Existing)	4	2 / DGN2	1
	planrd	GradeLineRt_pr	Grade Line Profile Right	4	0 / Continuous	2
	planrd	GradeSecPat	Grade Section Patterns	0	0 / Continuous	0
	planrd	GridMaj_dp	Grid Lines Major in Profile and Cross Section	3	0 / Continuous	1
	planrd	GridMin_dp	Grid Lines Minor in Profile and Cross Section	0	0 / Continuous	0
	planrd	GridMinSub_dp	Grid Lines Minor Sub on Cross Section Sheets	20	0 / Continuous	0
	planrd	ImageAttachment_dp	Image Attachments	0	0 / Continuous	0
	planrd	KeyShtMisc	Key Sheet Items (Miscellaneous)	0	0 / Continuous	2
	planrd	LeaderLine_dp	Leader Line and Terminator with Text	0	0 / Continuous	1
	planrd	Logo_dp	Consultant Engineer of Record Logo	0	0 / Continuous	1
	planrd	MatchLineMask_dp	Mask Area for Match Line Overlap Areas (For AutoCAD Use)	0	0 / Continuous	0
	planrd	MatchLines_dp	Match Lines with Text, Arrows for Station Notations	1	0 / Continuous	2
	planrd	Miscellaneous0	Undefined Proposed Item - Color Blue Weight 0	1	0 / Continuous	0
	planrd	Miscellaneous1	Undefined Proposed Item - Color Blue Weight 1	1	0 / Continuous	1
	planrd	Miscellaneous2	Undefined Proposed Item - Color Blue Weight 2	1	0 / Continuous	2
	planrd	Miscellaneous3	Undefined Proposed Item - Color Green Weight 0	2	0 / Continuous	0
	planrd	Miscellaneous4	Undefined Proposed Item - Color Green Weight 1	2	0 / Continuous	1
	planrd	Miscellaneous5	Undefined Proposed Item - Color Green Weight 2	2	0 / Continuous	2
	planrd	Miscellaneous6	Undefined Proposed Item - Color Red Weight 0	3	0 / Continuous	0
	planrd	Miscellaneous7	Undefined Proposed Item - Color Red Weight 1	3	0 / Continuous	1
	planrd	Miscellaneous8	Undefined Proposed Item - Color Red Weight 2	3	0 / Continuous	2
	planrd	Miscellaneous9	Undefined Proposed Item - Color Red Weight 3	3	0 / Continuous	3
	planrd	NonPlottingEle_dp	Non-Plotting Items - Construction Elements, Type 66 Elements, Etc.	4	0 / Continuous	0
	planrd	NorthArw_dp	North Arrows	0	0 / Continuous	2
	planrd	Patternlines_ep	Cross Section Chain (Existing)	2	1 / DGN1	0
	planrd	PatternLines1_dp	Pattern Lines on Cross Sections and All Autodesk (Civil 3D) Tables	3	0 / Continuous	2
	planrd	PatternLines2_dp	Pattern Lines on Cross Sections Alternate for Side Streets, Critical Cross Sections or Drainage Structures	4	0 / Continuous	2
	planrd	PatternLines3_dp	Pattern Lines on Cross Sections Alternate for Side Streets, Critical Cross Sections or Drainage Structures	5	0 / Continuous	2
	planrd	PayItem_dp	Pay Item Number Label Elements	4	0 / Continuous	2
X	planrd	PlotBorder_dp	Plot Border	3	0 / Continuous	0
	planrd	PointLocator_ep	Point Locator Symbol (Existing)	4	0 / Continuous	0
	planrd	ReferencePt_dp	Survey and Construction Reference Point Details and Elements	4	0 / Continuous	2
	planrd	RefPtAngleTie	Annotation: Angle Tie: Survey Reference Point / Detail	0	RW-Dimension-Type1 / Continuous	1
	planrd	RefPtLine	Survey Reference Point Line / Detail (Miscellaneous)	0	0 / Continuous	1
	planrd	Scale_dp	Bar Scale, Scale Label Elements	0	0 / Continuous	2
	planrd	Scratch1_dp	Scratch Level for Temporary or Informational Items	4	0 / Continuous	0
	planrd	Scratch2_dp	Scratch Level for Temporary or Informational Items	5	0 / Continuous	0
	planrd	ScratchEle_dp	Scratch Level for Draft Elements, Temporary Elements, Etc. (DO NOT PLOT)	3	0 / Continuous	0
	planrd	ScratchEle2_dp	Scratch Level for Draft Elements, Temporary Elements, Etc. (DO NOT PLOT)	4	0 / Continuous	0
	planrd	SheetBorder_dp	Sheet Border	1	0 / Continuous	4
	planrd	SheetLines_dp	Sheet Lines	1	0 / Continuous	2

Critical	Rule	Level Name	Level Description	ByLevel Color	ByLevelStyle / Linetype	ByLevel Weight
	planrd	SheetLinesMisc1_dp	Sheet Lines	1	0 / Continuous	0
	planrd	SheetLinesMisc2_dp	Sheet Lines	2	0 / Continuous	2
	planrd	SheetLinesMisc3_dp	Sheet Lines	3	0 / Continuous	2
	planrd	SheetLinesMisc4_dp	Sheet Lines	4	0 / Continuous	2
	planrd	StationTicL_dp	Station Tic Marks (Large) and Text	0	0 / Continuous	2
	planrd	StationTicS_dp	Station Tic Marks (Small) and Text	0	0 / Continuous	2
	planrd	SumBoxBorder_dp	Summary Boxes Borders	4	0 / Continuous	3
	planrd	SumBoxLines_dp	Summary Boxes Lines and Miscellaneous Items	4	0 / Continuous	1
	planrd	SumBoxLinesMin_dp	Summary Boxes Lines Minor Line and Miscellaneous Items	4	0 / Continuous	0
	planrd	Tables_dp	Data Tables and All Autodesk Tables	0	0 / Continuous	1
	planrd	TextBLStation	Text - B/L Station and Tics	0	0 / Continuous	2
	planrd	TextConstEle	Text - Construction Element	0	0 / Continuous	1
	planrd	TextCurveData	Text - Curve Data Note	0	0 / Continuous	2
	planrd	TextDetails	Text - Detail Notes	4	0 / Continuous	2
	planrd	TextDrainInvElev_ep	Text - Drainage Invert Elevation (Existing)	0	0 / Continuous	1
	planrd	TextDrainLabel_ep	Text - Drainage (Existing)	0	0 / Continuous	1
	planrd	TextElevLabel	Text - Elevation Labels	4	0 / Continuous	0
	planrd	TextLabel	Text - Label	0	0 / Continuous	2
	planrd	TextLandscape	Text - Landscape Labels	0	0 / Continuous	1
	planrd	TextMajor	Text - Major	0	0 / Continuous	5
	planrd	TextMinor	Text - Minor	0	0 / Continuous	0
	planrd	TextMisc	Text - Miscellaneous	0	0 / Continuous	1
	planrd	TextNotes	Text - Notes	4	0 / Continuous	1
	planrd	TextProfLabel	Text - Profile, Horizontal and Vertical Axis Labels	0	0 / Continuous	2
	planrd	TextProjLabel	Text - Begin and End Project Label with Leader Lines	1	0 / Continuous	2
	planrd	TextPtLabel	Text - Point Labels	4	0 / Continuous	0
	planrd	TextShtNo	Text - Sheet Number	0	0 / Continuous	2
	planrd	TextSubUtilLabel_ep	Text - Subsurface Utilities (Existing)	0	0 / Continuous	1
	planrd	TextSurveyLabel	Text - Survey Labels	0	0 / Continuous	0
	planrd	TextTables	Text - Key Sheet Indexes and Table Data	4	0 / Continuous	2
	planrd	TextTitle	Text - Title	0	0 / Continuous	3
	planrd	TextTopoLabel_ep	Text - Topography (Existing)	0	0 / Continuous	1
	planrd	TextUtilLabel_ep	Text - Utilities (Existing)	0	0 / Continuous	1
	planrd	TextXSElev	Text - Cross Section Elevations	2	0 / Continuous	1
	planrd	Viewport	Viewport (For AutoCAD Use)	3	0 / Continuous	0
	planrd	Wetland	Wetland Boundary	2	RD-Wetland-Proposed	1
	planrd	Xreference01_dp	Reference Files (For AutoCAD Use)	0	0 / Continuous	1
	planrd	Xreference02_dp	Reference Files (For AutoCAD Use)	0	0 / Continuous	1
	planrd	Xreference03_dp	Reference Files (For AutoCAD Use)	0	0 / Continuous	1
	planrd	Xreference04_dp	Reference Files (For AutoCAD Use)	0	0 / Continuous	1
	planrd	XSCell	GEOPAK Cross Section Cell/Block and Profile Cell/Block	8	0 / Continuous	1

## PLPRRD - Roadway Plan/Profile Sheet

Critical	Rule	Level Name	Level Description	ByLevel Color	ByLevelStyle / Linetype	ByLevel Weight
	plprrd	ActivePointCell_dp	Active Point Cell	4	0 / Continuous	10
	plprrd	AdhocPoint_dp	Adhoc Points Placed by SheetInfo	0	4 / DGN4	0
	plprrd	BaselineSurvey	Baseline Survey	0	0 / Continuous	2
	plprrd	CLConst_dp	Center Line of Construction	0	0 / Continuous	2
	plprrd	ClipBorder_dp	CLIP Border and Civil 3D View Frame	3	0 / Continuous	0
	plprrd	ClipDrawingBound_dp	CLIP Drawing Boundary	3	3 / DGN3	0
	plprrd	Cloud_dp	Construction Cloud	7	0 / Continuous	2
	plprrd	COGO_dp	COGO Information	3	0 / Continuous	1
X	plprrd	ConduitAG	Conduit (Above Ground)	4	SG-ConduitAG-Proposed	1
X	plprrd	ConduitBM	Conduit – Bridge Mount	5	SG-ConduitBM-Proposed	1
X	plprrd	ConduitDB	Conduit – Directional Bore	2	SG-ConduitDB-Proposed	1
X	plprrd	ConduitJB	Conduit – Jack & Bore Under Rail	3	SG-ConduitJB-Proposed	1
X	plprrd	ConduitOT	Conduit – Open Trench	1	SG-ConduitOT-Proposed	1
	plprrd	ConstArea_dp	Construction Area Crosshatch	0	0 / Continuous	1
	plprrd	ConstLimits	Construction Limits	3	RW-LimitsOfConst	2
	plprrd	ConstLines	Construction Lines and References	1	0 / Continuous	0
	plprrd	ConstLines_pm	Construction Lines	4	0 / Continuous	0
X	plprrd	Controller_ep	Controller and Accessories (Existing)	0	2 / DGN2	1
X	plprrd	ControllerB_ep	Controller - Base Mounted (Existing)	0	2 / DGN2	1
X	plprrd	ControllerP_ep	Controller Pole Mount (Existing)	0	2 / DGN2	1
	plprrd	CurveData_dp	Curve & Coordinate Data Elements IncludingPC, PT, PI Symbols	4	0 / Continuous	2
	plprrd	CurveDataLabel_dp	Curve Data Labels PC,PI, PT	0	0 / Continuous	2
	plprrd	DimLines_dp	Dimension Lines, Corresponding Terminators, Equation Lines	0	0 / Continuous	1
	plprrd	DitchProfLt_er	Ditch Profile Left (Existing)	8	3 / DGN3	1
	plprrd	DitchProfLt_pr	Ditch Profile Left	8	0 / Continuous	1
	plprrd	DitchProfMdn_er	Ditch Profile Median (Existing)	10	3 / DGN3	1
	plprrd	DitchProfMdn_pr	Ditch Profile Median	10	0 / Continuous	1
	plprrd	DitchProfRt_er	Ditch Profile Right (Existing)	9	3 / DGN3	1
	plprrd	DitchProfRt_pr	Ditch Profile Right	9	0 / Continuous	1
	plprrd	DrainDivides00	Drainage Divides	10	2 / DGN2	4
	plprrd	DrainDivides00_ep	Drainage Divides (Existing)	9	2 / DGN2	4
	plprrd	DrainDivides01	Drainage Divides	10	2 / DGN2	4
	plprrd	DrainDivides01_ep	Drainage Divides (Existing)	9	2 / DGN2	4
	plprrd	DrainDivides02	Drainage Divides	10	2 / DGN2	4
	plprrd	DrainDivides02_ep	Drainage Divides (Existing)	9	2 / DGN2	4
	plprrd	DrainDivides03	Drainage Divides	10	2 / DGN2	4
	plprrd	DrainDivides03_ep	Drainage Divides (Existing)	9	2 / DGN2	4
	plprrd	DrainDivides04	Drainage Divides	10	2 / DGN2	4
	plprrd	DrainDivides04_ep	Drainage Divides (Existing)	9	2 / DGN2	4
	plprrd	DrainDivides05	Drainage Divides	10	2 / DGN2	4
	plprrd	DrainDivides05_ep	Drainage Divides (Existing)	9	2 / DGN2	4
	plprrd	DrainDivides06	Drainage Divides	10	2 / DGN2	4
	plprrd	DrainDivides06_ep	Drainage Divides (Existing)	9	2 / DGN2	4
	plprrd	DrainDivides07	Drainage Divides	10	2 / DGN2	4
	plprrd	DrainDivides07_ep	Drainage Divides (Existing)	9	2 / DGN2	4
	plprrd	DrainDivides08	Drainage Divides	10	2 / DGN2	4



Critical	Rule	Level Name	Level Description	ByLevel Color	ByLevelStyle / Linetype	ByLevel Weight
	plprdd	DrainDivides08_ep	Drainage Divides (Existing)	9	2 / DGN2	4
	plprdd	DrainDivides09	Drainage Divides	10	2 / DGN2	4
	plprdd	DrainDivides09_ep	Drainage Divides (Existing)	9	2 / DGN2	4
	plprdd	DrainMisc	Drainage Items (Miscellaneous)	10	0 / Continuous	1
	plprdd	DrainMisc_pm	Drainage Items (Proposed Model) (Miscellaneous)	10	0 / Continuous	1
X	plprdd	DrainStruct_pr	Drainage Structures (All Types)	10	0 / Continuous	2
X	plprdd	EaseLicLine	Easement License Agreement Line	5	6 / DGN6	0
	plprdd	FLMap1	Florida Map items - Weight of 1	1	0 / Continuous	1
	plprdd	FLMap2	Florida Map items - Weight of 2	3	0 / Continuous	2
	plprdd	FLMap3	Florida Map items - Weight of 3	2	0 / Continuous	3
	plprdd	FLMap4	Florida Map items - Color 11 (Interstate)	11	0 / Continuous	3
	plprdd	FLMap5	Florida Map items - Style 7, Weight 5 (State Line)	3	7 / DGN7	5
	plprdd	FlowLine_pr	Flow Line (Roadway Profile View)	0	0 / Continuous	2
	plprdd	GeotechFillPatt1	Geotechnical Fill Pattern - (Earth, Wood, Muck, Concrete, Rock, Riprap) as Defined in Project	3	0 / Continuous	0
	plprdd	GeotechFillPatt1_px	Geotechnical Fill Pattern on Cross Sections (Earth, Wood, Muck, Concrete, Rock, Riprap) as Defined in Project	3	0 / Continuous	0
	plprdd	GeotechFillPatt2	Geotechnical Fill Pattern - Clay, Sand	0	1 / DGN1	0
	plprdd	GeotechFillPatt2_px	Geotechnical Fill Pattern on Cross Sections - Clay, Sand	0	1 / DGN1	0
	plprdd	GeotechFillPatt3	Geotechnical Fill Pattern - Shell	3	1 / DGN1	0
	plprdd	GeotechFillPatt3_px	Geotechnical Fill Pattern on Cross Sections- Shell	3	1 / DGN1	0
	plprdd	GeotechFillPatt4	Geotechnical Fill Pattern - Sand	4	0 / Continuous	0
	plprdd	GeotechFillPatt4_px	Geotechnical Fill Pattern on Cross Sections - Sand	4	0 / Continuous	0
	plprdd	GeotechFillPatt5	Geotechnical Fill Pattern - Coquina	1	0 / Continuous	1
	plprdd	GeotechFillPatt5_px	Geotechnical Fill Pattern on Cross Sections - Coquina	1	0 / Continuous	1
	plprdd	GeotechFillPatt6	Geotechnical Fill Pattern - Limestone	2	0 / Continuous	0
	plprdd	GeotechFillPatt6_px	Geotechnical Fill Pattern on Cross Sections- Limestone	2	0 / Continuous	0
	plprdd	GeotechFillPatt7	Geotechnical Fill Pattern - Gravel	6	0 / Continuous	0
	plprdd	GeotechFillPatt7_px	Geotechnical Fill Pattern on Cross Sections - Gravel	6	0 / Continuous	0
	plprdd	GeotechFillPatt8	Geotechnical Fill Pattern - Silt	0	0 / Continuous	1
	plprdd	GeotechFillPatt8_px	Geotechnical Fill Pattern on Cross Sections - Silt	0	0 / Continuous	1
	plprdd	GeotechMisc	Geotechnical Elements (Miscellaneous)	0	0 / Continuous	1
	plprdd	GPKDrBack_dp	Back Point on Drainage Cells	2	2 / DGN2	2
	plprdd	GPKDrBottom_dp	Bottom Point on Drainage Cells	3	3 / DGN3	2
	plprdd	GPKDrCellIns_dp	Cell Insertion Point on Drainage Cells	4	4 / DGN4	2
	plprdd	GPKDrCentroid_dp	Point on Centroid for Drainage	7	7 / DGN7	2
	plprdd	GPKDrFront_dp	Front Point on Drainage Cells	1	1 / DGN1	2
	plprdd	GPKDrPipe_dp	Point on Drainage Pipe	6	6 / DGN6	2
	plprdd	GPKDrPipeCir_dp	Point on Pipe Circular	6	6 / DGN6	0
	plprdd	GradeLine_er	Grade Line Profile (Existing)	2	2 / DGN2	1
	plprdd	GradeLine_pr	Grade Line Profile	5	0 / Continuous	2
	plprdd	GradeLineCtr_dp	Grade Line Profile Center (Shown in Plan View)	5	0 / Continuous	0
	plprdd	GradeLineCtr_pr	Grade Line Profile Center	5	0 / Continuous	2
	plprdd	GradeLineLt_dp	Grade Line Profile Left (Shown in Plan View)	1	0 / Continuous	0
	plprdd	GradeLineLt_er	Grade Line Profile Left (Existing)	1	2 / DGN2	1
	plprdd	GradeLineLt_pr	Grade Line Profile Left	1	0 / Continuous	2
	plprdd	GradeLineRt_dp	Grade Line Profile Right (Shown in Plan View)	4	0 / Continuous	0
	plprdd	GradeLineRt_er	Grade Line Profile Right (Existing)	4	2 / DGN2	1
	plprdd	GradeLineRt_pr	Grade Line Profile Right	4	0 / Continuous	2

Critical	Rule	Level Name	Level Description	ByLevel Color	ByLevelStyle / Linetype	ByLevel Weight
	plprdd	GradeSecPat	Grade Section Patterns	0	0 / Continuous	0
	plprdd	GridMaj_dp	Grid Lines Major in Profile and Cross Section	3	0 / Continuous	1
	plprdd	GridMin_dp	Grid Lines Minor in Profile and Cross Section	0	0 / Continuous	0
	plprdd	GridMinG_dp	Grid Lines Minor Sub 2 on Cross Section Sheets	20	0 / Continuous	0
	plprdd	GridMinSub_dp	Grid Lines Minor Sub on Cross Section Sheets	20	0 / Continuous	0
	plprdd	ImageAttachment_dp	Image Attachments	0	0 / Continuous	0
X	plprdd	InterconCable_ep	Interconnect Cable (Existing)	1	SG-InterconCable-Existing	0
	plprdd	KeyShtMisc	Key Sheet Items (Miscellaneous)	0	0 / Continuous	2
	plprdd	LaneDirArrow	Lane Directional Arrow	0	0 / Continuous	1
	plprdd	LeaderLine_dp	Leader Line and Terminator with Text	0	0 / Continuous	1
X	plprdd	LoadCenter	Load Center	2	0 / Continuous	1
X	plprdd	LoadCenter_ep	Load Center (Existing)	2	5 / DGN5	0
	plprdd	Logo_dp	Consultant Engineer of Record Logo	0	0 / Continuous	1
X	plprdd	LoopLI_ep	Loop Lead-In (Existing)	3	2 / DGN2	0
X	plprdd	Loops_ep	Loop Assembly (All Types) (Existing)	2	2 / DGN2	2
X	plprdd	Luminaire	Luminaires (Decorative - All Types)	2	0 / Continuous	1
	plprdd	MatchLineMask_dp	Mask Area for Match Line Overlap Areas (For AutoCAD Use)	0	0 / Continuous	0
	plprdd	MatchLines_dp	Match Lines with Text, Arrows for Station Notations	1	0 / Continuous	2
	plprdd	Miscellaneous0	Undefined Proposed Item - Color Blue Weight 0	1	0 / Continuous	0
	plprdd	Miscellaneous1	Undefined Proposed Item - Color Blue Weight 1	1	0 / Continuous	1
	plprdd	Miscellaneous2	Undefined Proposed Item - Color Blue Weight 2	1	0 / Continuous	2
	plprdd	Miscellaneous3	Undefined Proposed Item - Color Green Weight 0	2	0 / Continuous	0
	plprdd	Miscellaneous4	Undefined Proposed Item - Color Green Weight 1	2	0 / Continuous	1
	plprdd	Miscellaneous5	Undefined Proposed Item - Color Green Weight 2	2	0 / Continuous	2
	plprdd	Miscellaneous6	Undefined Proposed Item - Color Red Weight 0	3	0 / Continuous	0
	plprdd	Miscellaneous7	Undefined Proposed Item - Color Red Weight 1	3	0 / Continuous	1
	plprdd	Miscellaneous8	Undefined Proposed Item - Color Red Weight 2	3	0 / Continuous	2
	plprdd	Miscellaneous9	Undefined Proposed Item - Color Red Weight 3	3	0 / Continuous	3
	plprdd	NonPlottingEle_dp	Non-Plotting Items - Construction Elements, Type 66 Elements, Etc.	4	0 / Continuous	0
	plprdd	NorthArw_dp	North Arrows	0	0 / Continuous	2
X	plprdd	OverheadSign_ep	Overhead Sign Panels (Existing)	0	3 / DGN3	1
X	plprdd	OverheadStr_ep	Mast Arm, Truss Assemblies, Signal Arms and Supports (Existing)	0	3 / DGN3	1
	plprdd	PayItem_dp	Pay Item Number Label Elements	4	0 / Continuous	2
X	plprdd	Pedestal_ep	Pedestal (Existing)	1	2 / DGN2	1
X	plprdd	PedHead_ep	Pedestrian Head (All Types) (Existing)	0	2 / DGN2	1
X	plprdd	PipeCulvert_pr	Pipe Culvert in Profile	10	0 / Continuous	2
X	plprdd	PlotBorder_dp	Plot Border	3	0 / Continuous	0
X	plprdd	PoleConc	Concrete Strain Pole	0	0 / Continuous	2
X	plprdd	PoleConc_ep	Concrete Strain Pole (Existing)	0	2 / DGN2	1
X	plprdd	PoleFound	Pole Foundation	0	0 / Continuous	2
X	plprdd	PoleLight	Light Pole	2	0 / Continuous	1
X	plprdd	PoleLight_ep	Light Pole (Existing)	2	2 / DGN2	1
X	plprdd	PoleLightHM	High Mast Light Pole	3	0 / Continuous	1
X	plprdd	PoleLightHM_ep	High Mast Light Pole (Existing)	2	2 / DGN2	1
	plprdd	PoleLightID	Light Pole Location / ID	4	0 / Continuous	1
X	plprdd	PropertyLine_ep	Property Lines (Existing)	3	0 / Continuous	0
X	plprdd	PullBox	Pull Boxes (All Types)	3	0 / Continuous	1
	plprdd	ReferencePt_dp	Survey and Construction Reference Point Details and Elements	4	0 / Continuous	2



Critical	Rule	Level Name	Level Description	ByLevel Color	ByLevelStyle / Linetype	ByLevel Weight
	plprrd	RoadwayMisc	Roadway Items (Miscellaneous)	4	0 / Continuous	2
X	plprrd	RWLine	Right of Way Lines	4	RW-Proposed	2
X	plprrd	RWLine_ep	Right of Way Lines (Existing)	3	RW-Existing	1
	plprrd	Scale_dp	Bar Scale, Scale Label Elements	0	0 / Continuous	2
	plprrd	Scratch1_dp	Scratch Level for Temporary or Informational Items	4	0 / Continuous	0
	plprrd	Scratch2_dp	Scratch Level for Temporary or Informational Items	5	0 / Continuous	0
	plprrd	ScratchEle_dp	Scratch Level for Draft Elements, Temporary Elements, Etc. (DO NOT PLOT)	3	0 / Continuous	0
	plprrd	ScratchEle2_dp	Scratch Level for Draft Elements, Temporary Elements, Etc. (DO NOT PLOT)	4	0 / Continuous	0
	plprrd	SheetBorder_dp	Sheet Border	1	0 / Continuous	4
	plprrd	SheetLines_dp	Sheet Lines	1	0 / Continuous	2
	plprrd	SheetLinesMisc1_dp	Sheet Lines	1	0 / Continuous	0
	plprrd	SheetLinesMisc2_dp	Sheet Lines	2	0 / Continuous	2
	plprrd	SheetLinesMisc3_dp	Sheet Lines	3	0 / Continuous	2
	plprrd	SheetLinesMisc4_dp	Sheet Lines	4	0 / Continuous	2
	plprrd	SidewalkBack_er	Back of Sidewalk Line Profile (Existing)	2	2 / DGN2	1
	plprrd	SidewalkBack_pr	Back of Sidewalk Line Profile	5	0 / Continuous	2
X	plprrd	SignalHead_ep	Signal Head Section Details (Existing)	2	2 / DGN2	0
X	plprrd	SignalSym_ep	Signal Head Symbols (Existing)	3	2 / DGN2	0
X	plprrd	SignCantilever_ep	Sign Symbol Cantilever (Existing)	0	2 / DGN2	0
X	plprrd	SignPanel_ep	Sign Panel Elements (Existing)	0	2 / DGN2	1
X	plprrd	SignSpanwire	Span Wire Signing Assembly	2	0 / Continuous	1
X	plprrd	SignSpanwire_ep	Span Wire Signing Assembly (Existing)	2	2 / DGN2	1
X	plprrd	SignTruss_ep	Sign Symbol Truss (Existing)	3	2 / DGN2	1
	plprrd	StationTicL_dp	Station Tic Marks (Large) and Text	0	0 / Continuous	2
	plprrd	StationTicS_dp	Station Tic Marks (Small) and Text	0	0 / Continuous	2
X	plprrd	StreetLights	Street Lights	2	0 / Continuous	1
	plprrd	SumBoxBorder_dp	Summary Boxes Borders	4	0 / Continuous	3
	plprrd	SumBoxLines_dp	Summary Boxes Lines and Miscellaneous Items	4	0 / Continuous	1
	plprrd	SumBoxLinesMin_dp	Summary Boxes Lines Minor Line and Miscellaneous Items	4	0 / Continuous	0
	plprrd	Tables_dp	Data Tables and All Autodesk Tables	0	0 / Continuous	1
	plprrd	TextAlert	Text - Alert Label to Highlight a Problem	3	0 / Continuous	2
	plprrd	TextBLStation	Text - B/L Station and Tics	0	0 / Continuous	2
	plprrd	TextConstEle	Text - Construction Element	0	0 / Continuous	1
	plprrd	TextCurveData	Text - Curve Data Note	0	0 / Continuous	2
	plprrd	TextDetails	Text - Detail Notes	4	0 / Continuous	2
	plprrd	TextDrainInvElev_ep	Text - Drainage Invert Elevation (Existing)	0	0 / Continuous	1
	plprrd	TextDrainLabel_ep	Text - Drainage (Existing)	0	0 / Continuous	1
	plprrd	TextElevLabel	Text - Elevation Labels	4	0 / Continuous	0
	plprrd	TextGeotech	Text - Soil Borings and Labels	0	0 / Continuous	2
	plprrd	TextLabel	Text - Label	0	0 / Continuous	2
	plprrd	TextLandscape	Text - Landscape Labels	0	0 / Continuous	1
	plprrd	TextMajor	Text - Major	0	0 / Continuous	5
	plprrd	TextMinor	Text - Minor	0	0 / Continuous	0
	plprrd	TextMisc	Text - Miscellaneous	0	0 / Continuous	1
	plprrd	TextNotes	Text - Notes	4	0 / Continuous	1
	plprrd	TextProfLabel	Text - Profile, Horizontal and Vertical Axis Labels	0	0 / Continuous	2
	plprrd	TextProjLabel	Text - Begin and End Project Label with Leader Lines	1	0 / Continuous	2
	plprrd	TextPtLabel	Text - Point Labels	4	0 / Continuous	0

Critical	Rule	Level Name	Level Description	ByLevel Color	ByLevelStyle / Linetype	ByLevel Weight
	plprrd	TextShtNo	Text - Sheet Number	0	0 / Continuous	2
	plprrd	TextSubUtilLabel_ep	Text - Subsurface Utilities (Existing)	0	0 / Continuous	1
	plprrd	TextSurveyLabel	Text - Survey Labels	0	0 / Continuous	0
	plprrd	TextTables	Text - Key Sheet Indexes and Table Data	4	0 / Continuous	2
	plprrd	TextTitle	Text - Title	0	0 / Continuous	3
	plprrd	TextTopoLabel_ep	Text - Topography (Existing)	0	0 / Continuous	1
	plprrd	TextUtilLabel_ep	Text - Utilities (Existing)	0	0 / Continuous	1
	plprrd	TextXSElev	Text - Cross Section Elevations	2	0 / Continuous	1
	plprrd	TopoMisc_ep	Topography (Miscellaneous) (Existing)	0	3 / DGN3	1
	plprrd	Utility_er	Existing Utilities in Profile View	3	2 / DGN2	1
	plprrd	Utility_pr	Proposed Utilities in Profile View	3	0 / Continuous	2
	plprrd	Viewport	Viewport (For AutoCAD Use)	3	0 / Continuous	0
X	plprrd	WallRetain_pr	Retaining Wall Profile	9	0 / Continuous	2
	plprrd	Xreference01_dp	Reference Files (For AutoCAD Use)	0	0 / Continuous	1
	plprrd	Xreference02_dp	Reference Files (For AutoCAD Use)	0	0 / Continuous	1
	plprrd	Xreference03_dp	Reference Files (For AutoCAD Use)	0	0 / Continuous	1
	plprrd	Xreference04_dp	Reference Files (For AutoCAD Use)	0	0 / Continuous	1
	plprrd	XSCell	GEOPAK Cross Section Cell/Block and Profile Cell/Block	8	0 / Continuous	1

## QTDSRD - Quantity Computation

Critical	Rule	Level Name	Level Description	ByLevel Color	ByLevelStyle / Linetype	ByLevel Weight
	qtdsrd	ActivePointCell_dp	Active Point Cell	4	0 / Continuous	10
	qtdsrd	AdhocPoint_dp	Adhoc Points Placed by SheetInfo	0	4 / DGN4	0
X	qtdsrd	AdvWarnPanel	Advance Warning Arrow Panels	4	0 / Continuous	2
X	qtdsrd	AdvWarnVehicle	Work/Shadow/Advanced Warning Vehicle	3	0 / Continuous	2
X	qtdsrd	Aggregate	Aggregate	8	0 / Continuous	1
X	qtdsrd	ArtificialCovering	Artificial Coverings	10	0 / Continuous	2
X	qtdsrd	Attenuator	Attenuator Systems	6	MOT-Attenuator	1
X	qtdsrd	AttenuatorTM	Attenuator Truck Mount	6	0 / Continuous	2
X	qtdsrd	Barricade_px	Barricades Type I and II, Vertical Panels on Typical	6	0 / Continuous	2
X	qtdsrd	BarricadeIII	Barricade Type III	6	0 / Continuous	2
X	qtdsrd	BarricadeIII_px	Barricade Type III on Typical	6	0 / Continuous	2
X	qtdsrd	CandG_ex	Curb and Gutter on Cross Sections (All Types) (Existing)	4	2 / DGN2	1
X	qtdsrd	CandG_px	Curb and Gutter on Cross Sections (All Types)	4	0 / Continuous	2
X	qtdsrd	CandGBase_px	Curb and Gutter Base on Cross Sections	3	0 / Continuous	1
X	qtdsrd	ChannelDev	Channelizing Devices	0	0 / Continuous	2
X	qtdsrd	ChannelDevPed	Longitudinal Channelizing Device for Pedestrians	6	MOT-ChannelDevPed	2
X	qtdsrd	ChannelDevPed_px	Longitudinal Channelizing Device for Pedestrians on Typical	6	0 / Continuous	2
	qtdsrd	CLConst_dp	Center Line of Construction	0	0 / Continuous	2
X	qtdsrd	ClearingGrubbing	Clearing and Grubbing Limits and Quantity Items	4	0 / Continuous	1
	qtdsrd	ClipBorder_dp	CLIP Border and Civil 3D View Frame	3	0 / Continuous	0
	qtdsrd	ClipDrawingBound_dp	CLIP Drawing Boundary	3	3 / DGN3	0
	qtdsrd	Cloud_dp	Construction Cloud	7	0 / Continuous	2
X	qtdsrd	CmpFlashbrdRiser	Cmp Flashboard Riser	10	0 / Continuous	2
	qtdsrd	COGO_dp	COGO Information	3	0 / Continuous	1

Critical	Rule	Level Name	Level Description	ByLevel Color	ByLevelStyle / Linetype	ByLevel Weight
X	qt dsrd	Concrete	Concrete Areas and Miscellaneous (All Types)	0	0 / Continuous	2
X	qt dsrd	ConcSlabs	Concrete Slabs	0	0 / Continuous	2
X	qt dsrd	Cone_px	Cone and Tubular Marker on Typical	6	0 / Continuous	2
	qt dsrd	ConstArea_dp	Construction Area Crosshatch	0	0 / Continuous	1
	qt dsrd	ConstLimits	Construction Limits	3	RW-LimitsofConst	2
	qt dsrd	ConstLines	Construction Lines and References	1	0 / Continuous	0
	qt dsrd	ConstLines_pm	Construction Lines	4	0 / Continuous	0
X	qt dsrd	CurbBack	Back of Curb	4	0 / Continuous	1
X	qt dsrd	CurbFace	Curb and Gutter (Face)	4	0 / Continuous	1
X	qt dsrd	CurbRamp	Curb Cut Ramp	8	0 / Continuous	1
X	qt dsrd	CurbRampWarning	Detectable Warnings on Curb Ramps	4	0 / Continuous	2
	qt dsrd	CurveData_dp	Curve and Coordinate Data Elements Including PC, PT, PI Symbols	4	0 / Continuous	2
	qt dsrd	CurveDataLabel_dp	Curve Data Labels PC,PI, PT	0	0 / Continuous	2
	qt dsrd	DimLines_dp	Dimension Lines, Corresponding Terminators, Equation Lines	0	0 / Continuous	1
X	qt dsrd	DitchPavt	Ditch Pavement Including Quantity Shapes	3	0 / Continuous	1
	qt dsrd	Driveway	Driveway (Drive, Lane, Turnouts)	7	0 / Continuous	2
X	qt dsrd	Drum_px	Drum on Typical	6	0 / Continuous	2
X	qt dsrd	EaseLicLine	Easement License Agreement Line	5	6 / DGN6	0
X	qt dsrd	Flagman	Flagman	6	0 / Continuous	2
X	qt dsrd	FlowPaths	Time of Concentration Flow Paths	10	1 / DGN1	1
X	qt dsrd	Gabions	Gabion Baskets or Mats	10	0 / Continuous	2
X	qt dsrd	Gabions_ep	Gabion Baskets or Mats (Existing)	10	1 / DGN1	2
X	qt dsrd	Grass	Grass, Seeding and Mulching Areas	2	1 / DGN1	2
X	qt dsrd	Guardrail	Guardrail	1	0 / Continuous	1
X	qt dsrd	GuardrailBRLt	Guardrail Bridge (Left)	0	RD-Guardrail-Left	1
X	qt dsrd	GuardrailBRRt	Guardrail Bridge (Right)	0	RD-Guardrail-Right	1
X	qt dsrd	GuardrailDbl	Guardrail (Double Face)	0	RD-Guardrail-Double	1
X	qt dsrd	GuardrailEndAch	Guardrail (End Anchorage)	0	0 / Continuous	1
X	qt dsrd	GuardrailLt	Guardrail (Left)	0	RD-Guardrail-Left	1
X	qt dsrd	GuardrailModThrieDbl	Guardrail Modified Thrie Beam (Double Face)	0	RD-Guardrail-Double	1
X	qt dsrd	GuardrailModThrieLt	Guardrail Modified Thrie Beam (Left)	0	RD-Guardrail-Left	1
X	qt dsrd	GuardrailModThrieRt	Guardrail Modified Thrie Beam (Right)	0	RD-Guardrail-Right	1
X	qt dsrd	GuardrailPanel_px	Guardrail Component Property on Cross Sections for 3D Guardrail Panels	11	0 / Continuous	1
X	qt dsrd	GuardrailPost_px	Guardrail Component Property on Cross Sections for 3D Guardrail Posts	10	0 / Continuous	0
X	qt dsrd	GuardrailPRDbl	Guardrail Double Face w/ Pipe Rail	0	RD-Guardrail-Double	1
X	qt dsrd	GuardrailPRLt	Guardrail Left w/ Pipe Rail	0	RD-Guardrail-Left	1
X	qt dsrd	GuardrailPRRt	Guardrail Right w/ Pipe Rail	0	RD-Guardrail-Right	1
X	qt dsrd	GuardrailRRDbl	Guardrail Double Face w/ Rub Rail	0	RD-Guardrail-Double	1
X	qt dsrd	GuardrailRRLt	Guardrail Left w/ Rub Rail	0	RD-Guardrail-Left	1
X	qt dsrd	GuardrailRRRt	Guardrail Right w/ Rub Rail	0	RD-Guardrail-Right	1
X	qt dsrd	GuardrailRt	Guardrail Right	0	RD-Guardrail-Right	1
X	qt dsrd	GuardrailThrieDbl	Guardrail Thrie Beam Double Face	0	RD-Guardrail-Double	1
X	qt dsrd	GuardrailThrieLt	Guardrail Thrie Beam Left	0	RD-Guardrail-Left	1
X	qt dsrd	GuardrailThriePRLt	Guardrail Thrie Beam Left w/ Pipe Rail	0	RD-Guardrail-Left	1
X	qt dsrd	GuardrailThriePRRt	Guardrail Thrie Beam Right w/ Pipe Rail	0	RD-Guardrail-Right	1
X	qt dsrd	GuardrailThrieRt	Guardrail Thrie Beam Right	0	RD-Guardrail-Right	1
	qt dsrd	ImageAttachment_dp	Image Attachments	0	0 / Continuous	0
X	qt dsrd	InletProt	Rock Bags and Sand Bagging	10	SWP-RockBags	2

Critical	Rule	Level Name	Level Description	ByLevel Color	ByLevelStyle / Linetype	ByLevel Weight
	qtdsrd	LeaderLine_dp	Leader Line and Terminator with Text	0	0 / Continuous	1
X	qtdsrd	Mailbox	Mailboxes	8	0 / Continuous	1
	qtdsrd	MatchLines_dp	Match Lines with Text, Arrows for Station Notations	1	0 / Continuous	2
	qtdsrd	Miscellaneous0	Undefined Proposed Item - Color Blue Weight 0	1	0 / Continuous	0
	qtdsrd	Miscellaneous1	Undefined Proposed Item - Color Blue Weight 1	1	0 / Continuous	1
	qtdsrd	Miscellaneous2	Undefined Proposed Item - Color Blue Weight 2	1	0 / Continuous	2
	qtdsrd	Miscellaneous3	Undefined Proposed Item - Color Green Weight 0	2	0 / Continuous	0
	qtdsrd	Miscellaneous4	Undefined Proposed Item - Color Green Weight 1	2	0 / Continuous	1
	qtdsrd	Miscellaneous5	Undefined Proposed Item - Color Green Weight 2	2	0 / Continuous	2
	qtdsrd	Miscellaneous6	Undefined Proposed Item - Color Red Weight 0	3	0 / Continuous	0
	qtdsrd	Miscellaneous7	Undefined Proposed Item - Color Red Weight 1	3	0 / Continuous	1
	qtdsrd	Miscellaneous8	Undefined Proposed Item - Color Red Weight 2	3	0 / Continuous	2
	qtdsrd	Miscellaneous9	Undefined Proposed Item - Color Red Weight 3	3	0 / Continuous	3
X	qtdsrd	MowingAreaLarge	Mowing and Maintenance Areas for Large Machine	2	0 / Continuous	2
X	qtdsrd	MowingAreaSmall	Mowing and Maintenance Areas	68	0 / Continuous	1
X	qtdsrd	Mulch	Mulch Area	10	0 / Continuous	1
	qtdsrd	NonPlottingEle_dp	Non-Plotting Items - Construction Elements, Type 66 Elements, Etc.	4	0 / Continuous	0
X	qtdsrd	ObjectMarker	Object and Reflective Markers	3	0 / Continuous	1
X	qtdsrd	OverheadSign	Overhead Sign Panels	0	0 / Continuous	2
X	qtdsrd	OverheadSign_ep	Overhead Sign Panels (Existing)	0	3 / DGN3	1
X	qtdsrd	OverheadStr	Mast Arm, Truss Assemblies, Signal Arms and Supports	0	0 / Continuous	2
X	qtdsrd	OverheadStr_ep	Mast Arm, Truss Assemblies, Signal Arms and Supports (Existing)	0	3 / DGN3	1
	qtdsrd	Patternlines_ep	Cross Section Chain (Existing)	2	1 / DGN1	0
	qtdsrd	Pavers	Pavers - Brick and Block	5	0 / Continuous	1
X	qtdsrd	PavtAsphalt	Asphalt Pavement Edge Line and Quantity Shapes	0	0 / Continuous	2
	qtdsrd	PavtAsphalt_ep	Asphalt Pavement Edge (Existing)	0	3 / DGN3	1
X	qtdsrd	PavtBase	Base Material (All Types)	3	0 / Continuous	2
	qtdsrd	PavtConcrete_ep	Concrete Pavement (Edges) (Existing)	0	3 / DGN3	1
X	qtdsrd	PavtConcrete	Concrete Pavement Edge Lines and Quantity Shapes	10	0 / Continuous	2
X	qtdsrd	PavtConcreteSC	Concrete Surface Coloring	9	0 / Continuous	1
X	qtdsrd	PavtFrictionCourse	Asphalt Concrete Friction Course	4	0 / Continuous	2
X	qtdsrd	PavtMessage	Pavement Message (All Types)	0	0 / Continuous	1
X	qtdsrd	PavtMessage_ep	Pavement Message (All Types) (Existing)	0	2 / DGN2	0
	qtdsrd	PavtMilling	Milling and Resurfacing Limits and Quantity Shapes	1	0 / Continuous	2
	qtdsrd	PavtMisc	Asphalt Material (Miscellaneous)	1	0 / Continuous	1
X	qtdsrd	PavtStabilization	Stabilization Material Lines and Shapes	9	0 / Continuous	2
	qtdsrd	PavtXover_ep	Crossovers and Detours (Temporary) (Existing)	0	3 / DGN3	0
	qtdsrd	PayItem_dp	Pay Item Number Label Elements	4	0 / Continuous	2
	qtdsrd	Permit1	Permit 1 Wetlands, Mitigation Sites, Planting Areas	1	0 / Continuous	1
	qtdsrd	Permit2	Permit 2 Wetlands, Mitigation Sites, Planting Areas	2	0 / Continuous	1
	qtdsrd	Permit3	Permit 3 Wetlands, Mitigation Sites, Planting Areas	4	0 / Continuous	1
X	qtdsrd	PMCeramic	Pavement Markers Ceramic	0	0 / Continuous	1
	qtdsrd	PMMisc	Pavement Marking Items (Miscellaneous)	0	0 / Continuous	2
X	qtdsrd	PMStripe(10-10-20)	Pavement Marking 10/10/20 Skip Traffic Stripe 6in Contrast	0	PM-Stripe-10'_20'Skip / PM-Stripe-SKIP 10-10-20	2
X	qtdsrd	PMStripe(2-2-2)	Pavement Marking 2/2/2 Skip Traffic Stripe 6in Contrast	0	PM-Stripe-2'_2'Skip / PM-Stripe-SKIP 2-2-2	2
X	qtdsrd	PMStripe12B	Pavement Marking Traffic Stripe 12in Black	3	0 / Continuous	4
X	qtdsrd	PMStripe12W	Pavement Marking Traffic Stripe 12in White	0	0 / Continuous	4

Critical	Rule	Level Name	Level Description	ByLevel Color	ByLevelStyle / Linetype	ByLevel Weight
X	qtdsrd	PMStripe12W(2-4)	Pavement Marking 2/4 Skip Traffic Stripe 12in White	0	0 / PM-Stripe-SKIP 2-4	4
X	qtdsrd	PMStripe12W(3-9)	Pavement Marking 3/9 Skip Traffic Stripe 12in White	0	0 / PM-Stripe-SKIP 3-9	4
X	qtdsrd	PMStripe12Y	Pavement Marking Traffic Stripe 12in Yellow	4	0 / Continuous	4
X	qtdsrd	PMStripe16B	Pavement Marking Traffic Stripe 16in Black	3	0 / Continuous	5
X	qtdsrd	PMStripe16W	Pavement Marking Traffic Stripe 16in White	0	0 / Continuous	5
X	qtdsrd	PMStripe16Y	Pavement Marking Traffic Stripe 16in Yellow	4	0 / Continuous	5
X	qtdsrd	PMStripe18B	Pavement Marking Traffic Stripe 18in Black	3	0 / Continuous	6
X	qtdsrd	PMStripe18W	Pavement Marking Traffic Stripe 18in White	0	0 / Continuous	6
X	qtdsrd	PMStripe18Y	Pavement Marking Traffic Stripe 18in Yellow	4	0 / Continuous	6
X	qtdsrd	PMStripe24W	Pavement Marking Traffic Stripe 24in White	0	0 / Continuous	7
X	qtdsrd	PMStripe24Y	Pavement Marking Traffic Stripe 24in Yellow	4	0 / Continuous	7
X	qtdsrd	PMStripe6B	Pavement Marking Traffic Stripe 6in Black	3	0 / Continuous	2
X	qtdsrd	PMStripe6B(10-30)	Pavement Marking 10/30 Skip Traffic Stripe 6in Black	3	0 / PM-Stripe-SKIP 10-30	2
X	qtdsrd	PMStripe6Bl	Pavement Marking Traffic Stripe 6in Blue	1	0 / Continuous	2
X	qtdsrd	PMStripe6DY	Pavement Marking Traffic Stripe 6in Double Yellow	4	0 / Continuous	2
X	qtdsrd	PMStripe6W	Pavement Marking Traffic Stripe 6in White	0	0 / Continuous	2
X	qtdsrd	PMStripe6W(10-30)	Pavement Marking 10/30 Skip Traffic Stripe 6in White	0	0 / PM-Stripe-SKIP 10-30	2
X	qtdsrd	PMStripe6W(2-4)	Pavement Marking 2/4 Skip Traffic Stripe 6in White	0	0 / PM-Stripe-SKIP 2-4	2
X	qtdsrd	PMStripe6W(3-9)	Pavement Marking 3/9 Skip Traffic Stripe 6in White	0	0 / PM-Stripe-SKIP 3-9	2
X	qtdsrd	PMStripe6W(6-10)	Pavement Marking 6/10 Skip Traffic Stripe 6in White	0	0 / PM-Stripe-SKIP 6-10	2
X	qtdsrd	PMStripe6Y	Pavement Marking Traffic Stripe 6in Yellow	4	0 / Continuous	2
X	qtdsrd	PMStripe6Y(10-30)	Pavement Marking 10/30 Skip Traffic Stripe 6in Yellow	4	0 / PM-Stripe-SKIP 10-30	2
X	qtdsrd	PMStripe6Y(2-4)	Pavement Marking 2/4 Skip Traffic Stripe 6in Yellow	4	0 / PM-Stripe-SKIP 2-4	2
X	qtdsrd	PMStripe6Y(6-10)	Pavement Marking 6/10 Skip Traffic Stripe 6in Yellow	4	0 / PM-Stripe-SKIP 6-10	2
X	qtdsrd	PMStripe8B	Pavement Marking Traffic Stripe 8in Black	3	0 / Continuous	3
X	qtdsrd	PMStripe8W	Pavement Marking Traffic Stripe 8in White	0	0 / Continuous	3
X	qtdsrd	PMStripe8W(3-9)	Pavement Marking 3/9 Skip Traffic Stripe 8in White	0	0 / PM-Stripe-SKIP 3-9	2
X	qtdsrd	PMStripe8Y	Pavement Marking Traffic Stripe 8in Yellow	4	0 / Continuous	3
X	qtdsrd	PMStripe9C(10-30)	Pavement Marking 10/30 Skip Traffic Stripe 9in Contrast	0	0 / PM-Stripe-SKIP 10-30	2
X	qtdsrd	PMStripeRumbleCL	Center Line Rumble Stripes (Use to Quantify Rumble Strips) (NonPlotting)	4	PM-Stripe-RumbleStripeLeft / PM-Stripe-RumbleStripe	2
X	qtdsrd	PMStripeRumbleWL	Rumble Stripes (6in White Thermoplastic Over Rumble Strips) (Left)	0	PM-Stripe-RumbleStripeLeft / PM-Stripe-RumbleStripe	2
X	qtdsrd	PMStripeRumbleWR	Rumble Stripes (6in White Thermoplastic Over Rumble Strips) (Right)	0	PM-Stripe-RumbleStripeRight / PM-Stripe-RumbleStripe	2
X	qtdsrd	PMStripeRumbleYL	Rumble Stripes (6in Yellow Thermoplastic Over Rumble Strips) (Left)	4	PM-Stripe-RumbleStripeLeft / PM-Stripe-RumbleStripe	2
X	qtdsrd	PMStripeRumbleYR	Rumble Stripes (6in Yellow Thermoplastic Over Rumble Strips) (Right)	4	PM-Stripe-RumbleStripeRight / PM-Stripe-RumbleStripe	2
X	qtdsrd	PMStripeVibeWL	Pavement Marking Auditory and Vibratory 6in White (Left)	0	PM-Stripe-VibratoryLeft / PM-Stripe-Vibratory	2
X	qtdsrd	PMStripeVibeWR	Pavement Marking Auditory and Vibratory 6in White (Right)	0	PM-Stripe-VibratoryRight / PM-Stripe-Vibratory	2
X	qtdsrd	PMStripeVibeYL	Pavement Marking Auditory and Vibratory 6in Yellow (Left)	4	PM-Stripe-VibratoryLeft / PM-Stripe-Vibratory	2
X	qtdsrd	PMStripeVibeYR	Pavement Marking Auditory and Vibratory 6in Yellow (Right)	4	PM-Stripe-VibratoryRight / PM-Stripe-Vibratory	2
	qtdsrd	PointLocator_ep	Point Locator Symbol (Existing)	4	0 / Continuous	0
X	qtdsrd	PondSideSlope	Pond Side Slope	0	0 / Continuous	2
X	qtdsrd	Railing	Railings; Piperrail, Guiderail, Handrail used for Pedestrian and Bicycles (All)	9	0 / Continuous	2
	qtdsrd	ReferencePt_dp	Survey and Construction Reference Point Details and Elements	4	0 / Continuous	2
X	qtdsrd	ReflPaintWht	Reflective Paint - Island Nose (White)	0	0 / Continuous	3
X	qtdsrd	ReflPaintYel	Reflective Paint - Island Nose (Yellow)	4	0 / Continuous	3
X	qtdsrd	RetentionArea	Retention Area	2	0 / Continuous	2

Critical	Rule	Level Name	Level Description	ByLevel Color	ByLevelStyle / Linetype	ByLevel Weight
	qt dsrd	RoadwayMisc	Roadway Items (Miscellaneous)	4	0 / Continuous	2
X	qt dsrd	RockGravelStone	Rock, Gravel, Stone, Boulders, Etc.	1	0 / Continuous	2
X	qt dsrd	RPM_ep	Reflective Pavement Markers (Existing)	2	2 / DGN2	1
X	qt dsrd	RPM1	Raised Pavement Markers, White	0	0 / Continuous	2
X	qt dsrd	RPM2	Raised Pavement Markers, White - Red	3	0 / Continuous	2
X	qt dsrd	RPM3	Raised Pavement Markers, Yellow	4	0 / Continuous	2
X	qt dsrd	RPM4	Raised Pavement Markers, Yellow - Yellow	9	0 / Continuous	2
X	qt dsrd	RPM5	Raised Pavement Markers, Yellow - Red	6	0 / Continuous	2
X	qt dsrd	RPM6	Raised Pavement Markers, Blue	1	0 / Continuous	2
X	qt dsrd	RumbleStrip1	Rumble Strips Continuous Array	0	PM-RumbleSolid	2
X	qt dsrd	RumbleStrip2	Rumble Strips Skip Array	0	PM-RumbleSkip	2
	qt dsrd	Scratch1_dp	Scratch Level for Temporary or Informational Items	4	0 / Continuous	0
	qt dsrd	Scratch2_dp	Scratch Level for Temporary or Informational Items	5	0 / Continuous	0
	qt dsrd	ScratchEle_dp	Scratch Level for Draft Elements, Temporary Elements, Etc. (DO NOT PLOT)	3	0 / Continuous	0
	qt dsrd	ScratchEle2_dp	Scratch Level for Draft Elements, Temporary Elements, Etc. (DO NOT PLOT)	4	0 / Continuous	0
101	qt dsrd	SedimentBarrier	Synthetic Bales and Staked Silt Fences	10	SWP-HayBales	2
101	qt dsrd	SedimentBarrier	Synthetic Bales and Staked Silt Fences	10	SWP-SiltFence	2
X	qt dsrd	SedimentBasin	Sediment Basin Index 101	10	0 / Continuous	2
X	qt dsrd	SedimentBasin_ep	Sediment Basin Index 101 (Existing)	10	3 / DGN3	1
	qt dsrd	ShldrHatch	Shoulder Hatch Pattern	1	0 / RD-PavedShldr6	1
X	qt dsrd	ShldrPaved	Shoulder Line (Paved)	1	0 / Continuous	1
X	qt dsrd	ShldrUnpaved	Shoulder Line (Unpaved)	0	0 / Continuous	0
X	qt dsrd	SidewalkBack	Back of Sidewalk	2	0 / Continuous	1
X	qt dsrd	SidewalkConc	Sidewalk Concrete Shape	0	0 / Continuous	2
X	qt dsrd	SidewalkFront	Front of Sidewalk	1	0 / Continuous	1
X	qt dsrd	SignalWorkZone	Traffic Signal / Portable Signal	3	0 / Continuous	2
X	qt dsrd	SignCantilever	Sign Symbol Cantilever	0	0 / Continuous	1
X	qt dsrd	SignCantilever_ep	Sign Symbol Cantilever (Existing)	0	2 / DGN2	0
	qt dsrd	SignDetail	Sign Details	0	0 / Continuous	2
	qt dsrd	SignLettersAZ	Alphabet Cell Library Letter A-Z Numbers 0-9	0	0 / Continuous	0
	qt dsrd	SignMisc	Sign Symbols (Miscellaneous)	3	0 / Continuous	1
	qt dsrd	SignMisc_ep	Sign Symbols (Miscellaneous) (Existing)	1	1 / DGN1	1
X	qt dsrd	SignPanel	Sign Panels - Regulatory	0	0 / Continuous	2
X	qt dsrd	SignPanel_ep	Sign Panel Elements (Existing)	0	2 / DGN2	1
X	qt dsrd	SignPanelBorder	Sign Panel Border on Sign Details	0	0 / Continuous	1
X	qt dsrd	SignSpanwire	Span Wire Signing Assembly	2	0 / Continuous	1
X	qt dsrd	SignSpanwire_ep	Span Wire Signing Assembly (Existing)	2	2 / DGN2	1
X	qt dsrd	SignSpecial	Special Signs / Guide Signs	2	0 / Continuous	2
X	qt dsrd	SignSupport	Ground Mounted Sign Support Symbol (All Types)	1	0 / Continuous	1
	qt dsrd	SignSupport_ep	Trusses and Cantilevers for Overhead Signs (Existing)	0	3 / DGN3	1
X	qt dsrd	SignSymbol_px	Sign Structure and Foundation on Cross Sections	4	0 / Continuous	2
X	qt dsrd	SignTruss	Sign Symbol Truss	3	0 / Continuous	1
X	qt dsrd	SignTruss_ep	Sign Symbol Truss (Existing)	3	2 / DGN2	1
X	qt dsrd	SignWorkZone	Work Zone Signs	6	0 / Continuous	2
X	qt dsrd	Sod	Performance Sod	2	0 / Continuous	2
	qt dsrd	StationTicL_dp	Station Tic Marks (Large) and Text	0	0 / Continuous	2
	qt dsrd	StationTicS_dp	Station Tic Marks (Small) and Text	0	0 / Continuous	2
	qt dsrd	SuperPave	Asphaltic Concrete Super Pavement	6	0 / Continuous	2



Critical	Rule	Level Name	Level Description	ByLevel Color	ByLevelStyle / Linetype	ByLevel Weight
	qtdsrd	Tables_dp	Data Tables and All Autodesk Tables	0	0 / Continuous	1
	qtdsrd	TextAlert	Text - Alert Label to Highlight a Problem	3	0 / Continuous	2
	qtdsrd	TextBLStation	Text - B/L Station and Tics	0	0 / Continuous	2
	qtdsrd	TextConstEle	Text - Construction Element	0	0 / Continuous	1
	qtdsrd	TextCurveData	Text - Curve Data Note	0	0 / Continuous	2
	qtdsrd	TextDetails	Text - Detail Notes	4	0 / Continuous	2
	qtdsrd	TextDrainInvElev_ep	Text - Drainage Invert Elevation (Existing)	0	0 / Continuous	1
	qtdsrd	TextDrainLabel_ep	Text - Drainage (Existing)	0	0 / Continuous	1
	qtdsrd	TextElevLabel	Text - Elevation Labels	4	0 / Continuous	0
	qtdsrd	TextLabel	Text - Label	0	0 / Continuous	2
	qtdsrd	TextLandscape	Text - Landscape Labels	0	0 / Continuous	1
	qtdsrd	TextMajor	Text - Major	0	0 / Continuous	5
	qtdsrd	TextMinor	Text - Minor	0	0 / Continuous	0
	qtdsrd	TextMisc	Text - Miscellaneous	0	0 / Continuous	1
	qtdsrd	TextNotes	Text - Notes	4	0 / Continuous	1
	qtdsrd	TextProfLabel	Text - Profile, Horizontal and Vertical Axis Labels	0	0 / Continuous	2
	qtdsrd	TextProjLabel	Text - Begin and End Project Label with Leader Lines	1	0 / Continuous	2
	qtdsrd	TextPtLabel	Text - Point Labels	4	0 / Continuous	0
	qtdsrd	TextShtNo	Text - Sheet Number	0	0 / Continuous	2
	qtdsrd	TextSubUtilLabel_ep	Text - Subsurface Utilities (Existing)	0	0 / Continuous	1
	qtdsrd	TextSurveyLabel	Text - Survey Labels	0	0 / Continuous	0
	qtdsrd	TextTables	Text - Key Sheet Indexes and Table Data	4	0 / Continuous	2
	qtdsrd	TextTitle	Text - Title	0	0 / Continuous	3
	qtdsrd	TextTopoLabel_ep	Text - Topography (Existing)	0	0 / Continuous	1
	qtdsrd	TextUtilLabel_ep	Text - Utilities (Existing)	0	0 / Continuous	1
	qtdsrd	TextXSElev	Text - Cross Section Elevations	2	0 / Continuous	1
X	qtdsrd	TrafficControlMisc	Traffic Control Items (Miscellaneous)	3	0 / Continuous	1
X	qtdsrd	TrafSeparator	Traffic Separator (All Types)	6	0 / Continuous	1
X	qtdsrd	TubularMarker_px	Tubular Markers on Typical	6	0 / Continuous	2
X	qtdsrd	TurbidityBarrier1	Turbidity Barrier 1 (Floating)	10	SWP-TurbidityBarrier-Type1	2
	qtdsrd	TurbidityBarrier1_ep	Turbidity Barrier 1 (Floating) (Existing)	10	1 / DGN1	2
X	qtdsrd	TurbidityBarrier2	Turbidity Barrier 2 (Staked)	10	SWP-TurbidityBarrier-Type2	2
	qtdsrd	TurbidityBarrier2_ep	Turbidity Barrier 2 (Staked) (Existing)	10	1 / DGN1	2
X	qtdsrd	Turf	Performance Turf	100	0 / Continuous	2
	qtdsrd	Viewport	Viewport (For AutoCAD Use)	3	0 / Continuous	0
X	qtdsrd	WallBarrier	Barrier Wall (All Types)	6	0 / Continuous	2
X	qtdsrd	WallGravity	Gravity Wall	11	0 / Continuous	1
X	qtdsrd	WallTempBarrier_px	Barrier Wall (Temporary) on Typical	6	0 / Continuous	2
	qtdsrd	Wetland	Wetland Boundary	2	RD-Wetland-Proposed	1
	qtdsrd	Widening	Widening Patterns and Miscellaneous Elements	1	0 / Continuous	1
	qtdsrd	Xreference01_dp	Reference Files (For AutoCAD Use)	0	0 / Continuous	1
	qtdsrd	Xreference02_dp	Reference Files (For AutoCAD Use)	0	0 / Continuous	1
	qtdsrd	Xreference03_dp	Reference Files (For AutoCAD Use)	0	0 / Continuous	1
	qtdsrd	Xreference04_dp	Reference Files (For AutoCAD Use)	0	0 / Continuous	1
	qtdsrd	XSCell	GEOPAK Cross Section Cell/Block and Profile Cell/Block	8	0 / Continuous	1
	qtdsrd	XSPt_ep	Cross Section Point, Station (Existing)	2	1 / DGN1	0

## RDXSRD - Roadway Cross Section

Critical	Rule	Level Name	Level Description	ByLevel Color	ByLevelStyle / Linetype	ByLevel Weight
	rdxsrd	ActivePointCell_dp	Active Point Cell	4	0 / Continuous	10
	rdxsrd	AdhocPoint_dp	Adhoc Points Placed by SheetInfo	0	4 / DGN4	0
	rdxsrd	BaselineSurvey	Baseline Survey	0	0 / Continuous	2
X	rdxsrd	Berm_px	Berm (Top, Front, or Back) on Cross Sections	10	0 / Continuous	2
X	rdxsrd	Bridge_px	Bridge Component on Cross Sections - Component Property	0	0 / Continuous	2
X	rdxsrd	CableBarrier_px	Cable Barrier on Cross Sections	0	0 / Continuous	2
X	rdxsrd	CandG_ex	Curb and Gutter on Cross Sections (All Types) (Existing)	4	2 / DGN2	1
X	rdxsrd	CandG_px	Curb and Gutter on Cross Sections (All Types)	4	0 / Continuous	2
X	rdxsrd	CandGBase_px	Curb and Gutter Base on Cross Sections	3	0 / Continuous	1
X	rdxsrd	CATVBur_ex	Cable TV and Miscellaneous on Cross Sections (Buried) (Existing)	6	2 / DGN2	1
X	rdxsrd	CATVBur_px	Cable TV and Miscellaneous on Cross Sections (Buried)	6	0 / Continuous	1
	rdxsrd	CLConst_dp	Center Line of Construction	0	0 / Continuous	2
	rdxsrd	Cloud_dp	Construction Cloud	7	0 / Continuous	2
	rdxsrd	COGO_dp	COGO Information	3	0 / Continuous	1
X	rdxsrd	Concrete_px	Concrete Boundary Lines on Cross Sections	0	0 / Continuous	2
X	rdxsrd	Conduit_ex	Conduit and Encasements on Cross Sections (Existing)	3	2 / DGN2	1
X	rdxsrd	Conduit_px	Conduit and Encasements on Cross Sections	3	0 / Continuous	1
	rdxsrd	ConstArea_dp	Construction Area Crosshatch	0	0 / Continuous	1
	rdxsrd	ConstLimits	Construction Limits	3	RW-LimitsOfConst	2
	rdxsrd	ConstLines	Construction Lines and References	1	0 / Continuous	0
	rdxsrd	ConstLines_pm	Construction Lines	4	0 / Continuous	0
	rdxsrd	CurveData_dp	Curve and Coordinate Data Elements Including PC, PT, PI symbols	4	0 / Continuous	2
	rdxsrd	CurveDataLabel_dp	Curve Data Labels PC,PI, PT	0	0 / Continuous	2
	rdxsrd	DimLines_dp	Dimension Lines, Corresponding Terminators, Equation Lines	0	0 / Continuous	1
X	rdxsrd	Ditch_px	Ditch Top on Cross Sections	7	0 / Continuous	2
X	rdxsrd	DitchBot_px	Ditch Bottom on Cross Sections	10	0 / Continuous	2
X	rdxsrd	DitchPavt_px	Ditch Pavement on Cross Sections	3	0 / Continuous	3
	rdxsrd	DrainAlert_px	Alert Symbology for Structural Elements on Cross Sections	3	0 / Continuous	2
	rdxsrd	DrainMisc_ex	Drainage Elements on Cross Sections (All) (Miscellaneous) (Existing)	10	3 / DGN3	1
X	rdxsrd	DrainStruct_ex	Drainage Structures on Cross Sections (All) (Existing)	10	3 / DGN3	1
X	rdxsrd	DrainStruct_px	Drainage Structures and Elements on Cross Sections (Miscellaneous)	10	0 / Continuous	2
X	rdxsrd	Driveway_ex	Driveway Lines on Cross Sections (Existing)	7	2 / DGN2	2
X	rdxsrd	Driveway_px	Driveway Lines on Cross Sections	7	0 / Continuous	2
X	rdxsrd	DrivewayBase_px	Driveway Subgrade on Cross Sections	3	0 / Continuous	2
	rdxsrd	Earthwork1_px	Earthwork (Color 0) on Cross Sections	0	0 / Continuous	1
	rdxsrd	Earthwork2_px	Earthwork (Color 1) on Cross Sections	1	0 / Continuous	1
	rdxsrd	Earthwork3_px	Earthwork (Color 2) on Cross Sections	2	0 / Continuous	1
	rdxsrd	Earthwork4_px	Earthwork (Color 3) on Cross Sections	3	0 / Continuous	1
	rdxsrd	Earthwork5_px	Earthwork (Color 4) on Cross Sections	4	0 / Continuous	1
X	rdxsrd	EaseLicLine	Easement License Agreement Line	5	6 / DGN6	0
X	rdxsrd	EaseLine_ep	Easement Lines (Existing)	1	RW-Easement	1
X	rdxsrd	EasePerpLine_px	Easement Lines Perpetual on Cross Sections	4	RW-PerpetualEasement	12
X	rdxsrd	EaseTempLine_px	Easement Lines Temporary on Cross Sections	6	RW-TemporaryEasement	0
X	rdxsrd	ElecBur_ex	Electrical on Cross Sections (Buried) (Existing)	3	2 / DGN2	1



Critical	Rule	Level Name	Level Description	ByLevel Color	ByLevelStyle / Linetype	ByLevel Weight
X	rdxsrd	ElecBur_px	Electrical on Cross Sections (Buried)	3	0 / Continuous	1
X	rdxsrd	Endwall_px	Endwall on Cross Sections	10	0 / Continuous	2
	rdxsrd	ExcavationLimits_dp	Excavation Limits on Cross Sections	0	0 / Continuous	1
	rdxsrd	Fence_ex	Fence Lines on Cross Sections (Existing)	6	3 / DGN3	1
X	rdxsrd	Fence_px	Fence Lines on Cross Sections	6	RD-Fence	2
X	rdxsrd	FES_px	Flared End Sections on Cross Sections	10	0 / Continuous	2
X	rdxsrd	FOCBur_ex	Fiber Optics Cable on Cross Sections (Buried) (Existing)	6	2 / DGN2	1
X	rdxsrd	FOCBur_px	Fiber Optics Cable on Cross Sections (Buried)	6	0 / Continuous	1
X	rdxsrd	FOEElecBur_ex	Fiber Optics Electrical on Cross Sections (Buried) (Existing)	3	2 / DGN2	1
X	rdxsrd	FOEElecBur_px	Fiber Optics Electrical on Cross Sections (Buried)	3	0 / Continuous	1
X	rdxsrd	FOTBur_ex	Fiber Optics Telephone on Cross Sections (Buried) (Existing)	6	2 / DGN2	1
X	rdxsrd	FOTBur_px	Fiber Optics Telephone on Cross Sections (Buried)	6	0 / Continuous	1
X	rdxsrd	Gas_ex	Gas Pipe and Fittings on Cross Sections (Miscellaneous) (Existing)	4	2 / DGN2	1
X	rdxsrd	Gas_px	Gas Pipe and Fittings on Cross Sections (Miscellaneous)	4	0 / Continuous	1
	rdxsrd	GeotechFillPatt1	Geotechnical Fill Pattern - (Earth, Wood, Muck, Concrete, Rock, Riprap) as Defined in Project	3	0 / Continuous	0
	rdxsrd	GeotechFillPatt1_px	Geotechnical Fill Pattern on Cross Sections (Earth, Wood, Muck, Concrete, Rock, Riprap) as Defined in Project	3	0 / Continuous	0
	rdxsrd	GeotechFillPatt2	Geotechnical Fill Pattern - Clay, Sand	0	1 / DGN1	0
	rdxsrd	GeotechFillPatt2_px	Geotechnical Fill Pattern on Cross Sections - Clay, Sand	0	1 / DGN1	0
	rdxsrd	GeotechFillPatt3	Geotechnical Fill Pattern - Shell	3	1 / DGN1	0
	rdxsrd	GeotechFillPatt3_px	Geotechnical Fill Pattern on Cross Sections - Shell	3	1 / DGN1	0
	rdxsrd	GeotechFillPatt4	Geotechnical Fill Pattern - Sand	4	0 / Continuous	0
	rdxsrd	GeotechFillPatt4_px	Geotechnical Fill Pattern on Cross Sections - Sand	4	0 / Continuous	0
	rdxsrd	GeotechFillPatt5	Geotechnical Fill Pattern - Coquina	1	0 / Continuous	1
	rdxsrd	GeotechFillPatt5_px	Geotechnical Fill Pattern on Cross Sections - Coquina	1	0 / Continuous	1
	rdxsrd	GeotechFillPatt6	Geotechnical Fill Pattern - Limestone	2	0 / Continuous	0
	rdxsrd	GeotechFillPatt6_px	Geotechnical Fill Pattern on Cross Sections - Limestone	2	0 / Continuous	0
	rdxsrd	GeotechFillPatt7	Geotechnical Fill Pattern - Gravel	6	0 / Continuous	0
	rdxsrd	GeotechFillPatt7_px	Geotechnical Fill Pattern on Cross Sections - Gravel	6	0 / Continuous	0
	rdxsrd	GeotechFillPatt8	Geotechnical Fill Pattern - Silt	0	0 / Continuous	1
	rdxsrd	GeotechFillPatt8_px	Geotechnical Fill Pattern on Cross Sections - Silt	0	0 / Continuous	1
	rdxsrd	GeotechMisc	Geotechnical Elements (Miscellaneous)	0	0 / Continuous	1
	rdxsrd	GPKDrBack_dp	Back Point on Drainage Cells	2	2 / DGN2	2
	rdxsrd	GPKDrBottom_dp	Bottom Point on Drainage Cells	3	3 / DGN3	2
	rdxsrd	GPKDrCellIns_dp	Cell Insertion Point on Drainage Cells	4	4 / DGN4	2
	rdxsrd	GPKDrCentroid_dp	Point on Centroid for Drainage	7	7 / DGN7	2
	rdxsrd	GPKDrElv	Location Point for Drainage Cells	5	5 / DGN5	2
	rdxsrd	GPKDrFront_dp	Front Point on Drainage Cells	1	1 / DGN1	2
	rdxsrd	GPKDrPipe_dp	Point on Drainage Pipe	6	6 / DGN6	2
	rdxsrd	GPKDrPipeCir_dp	Point on Pipe Circular	6	6 / DGN6	0
	rdxsrd	GridMaj_dp	Grid Lines Major in Profile and Cross Section	3	0 / Continuous	1
	rdxsrd	GridMin_dp	Grid Lines Minor in Profile and Cross Section	0	0 / Continuous	0
	rdxsrd	GridMinG_dp	Grid Lines Minor Sub 2 on Cross Section Sheets	20	0 / Continuous	0
	rdxsrd	GridMinSub_dp	Grid Lines Minor Sub on Cross Section Sheets	20	0 / Continuous	0
X	rdxsrd	Guardrail_ex	Guardrail Lines on Cross Sections (Existing)	0	2 / DGN2	2
X	rdxsrd	GuardrailPanel_px	Guardrail Component Property on Cross Sections for 3D Guardrail Panels	11	0 / Continuous	1
X	rdxsrd	GuardrailPost_px	Guardrail Component Property on Cross Sections for 3D Guardrail Posts	10	0 / Continuous	0

Critical	Rule	Level Name	Level Description	ByLevel Color	ByLevelStyle / Linetype	ByLevel Weight
	rdxsrd	ImageAttachment_dp	Image Attachments	0	0 / Continuous	0
X	rdxsrd	Inlet_px	Inlets on Cross Sections	10	0 / Continuous	2
X	rdxsrd	InletBottom_px	Inlet Bottom on Cross Sections (All Types)	10	0 / Continuous	2
	rdxsrd	KeyShtMisc	Key Sheet Items (Miscellaneous)	0	0 / Continuous	2
X	rdxsrd	LARWLine_ex	Limited Access Right of Way Lines on Cross Sections (Existing)	4	RW-LimitedAccess-Existing	1
X	rdxsrd	LARWLine_px	Limited Access Right of Way Lines on Cross Sections	4	RW-LimitedAccess-Proposed	2
X	rdxsrd	LateralLimits_px	Lateral Limits on Cross Sections	6	0 / Continuous	2
	rdxsrd	LeaderLine_dp	Leader Line and Terminator with Text	0	0 / Continuous	1
	rdxsrd	Logo_dp	Consultant Engineer of Record Logo	0	0 / Continuous	1
	rdxsrd	Manhole_ex	Manhole on Cross Sections (Existing)	10	3 / DGN3	2
X	rdxsrd	Manhole_px	Manhole on Cross Sections	10	0 / Continuous	2
	rdxsrd	MatchLineMask_dp	Mask Area for Match Line Overlap Areas (For AutoCAD Use)	0	0 / Continuous	0
X	rdxsrd	MES_px	Mitered End Section on Cross Sections	10	0 / Continuous	2
	rdxsrd	Miscellaneous0	Undefined Proposed Item - Color Blue Weight 0	1	0 / Continuous	0
	rdxsrd	Miscellaneous1	Undefined Proposed Item - Color Blue Weight 1	1	0 / Continuous	1
	rdxsrd	Miscellaneous2	Undefined Proposed Item - Color Blue Weight 2	1	0 / Continuous	2
	rdxsrd	Miscellaneous3	Undefined Proposed Item - Color Green Weight 0	2	0 / Continuous	0
	rdxsrd	Miscellaneous4	Undefined Proposed Item - Color Green Weight 1	2	0 / Continuous	1
	rdxsrd	Miscellaneous5	Undefined Proposed Item - Color Green Weight 2	2	0 / Continuous	2
	rdxsrd	Miscellaneous6	Undefined Proposed Item - Color Red Weight 0	3	0 / Continuous	0
	rdxsrd	Miscellaneous7	Undefined Proposed Item - Color Red Weight 1	3	0 / Continuous	1
	rdxsrd	Miscellaneous8	Undefined Proposed Item - Color Red Weight 2	3	0 / Continuous	2
	rdxsrd	Miscellaneous9	Undefined Proposed Item - Color Red Weight 3	3	0 / Continuous	3
	rdxsrd	NonPlottingEle_dp	Non-Plotting Items - Construction Elements, Type 66 Elements, Etc.	4	0 / Continuous	0
	rdxsrd	Patternlines_ep	Cross Section Chain (Existing)	2	1 / DGN1	0
	rdxsrd	PatternLines1_dp	Pattern Lines on Cross Sections and All Autodesk (Civil 3D) Tables	3	0 / Continuous	2
	rdxsrd	PatternLines2_dp	Pattern Lines on Cross Sections Alternate for Side Streets, CriticalCross Sections or Drainage Structures	4	0 / Continuous	2
	rdxsrd	PatternLines3_dp	Pattern Lines on Cross Sections Alternate for Side Streets, CriticalCross Sections or Drainage Structures	5	0 / Continuous	2
X	rdxsrd	PavedMedianBase_px	Median Subgrade on Cross Sections (Paved)	3	0 / Continuous	2
	rdxsrd	PavtAsphalt_ep	Asphalt Pavement Edge (Existing)	0	3 / DGN3	1
X	rdxsrd	PavtAsphalt_px	Asphalt Pavement on Cross Sections and Components in Models	1	0 / Continuous	2
X	rdxsrd	PavtBase_ex	Base Material on Cross Sections (All Types) (Existing)	3	3 / DGN3	1
X	rdxsrd	PavtBase_px	Base Material on Cross Sections (All Types)	3	0 / Continuous	2
X	rdxsrd	PavtConcrete_px	Concrete Pavement on Cross Sections and Components in Models	0	0 / Continuous	2
X	rdxsrd	PavtMilling_px	Asphalt Milling Lines on Cross Sections	7	0 / Continuous	2
X	rdxsrd	PavtMisc_px	Pavement on Cross Sections (Miscellaneous)	1	0 / Continuous	2
X	rdxsrd	PavtOverbuild_px	Pavement Overbuild Areas on Cross Sections - Component Property	4	0 / Continuous	2
X	rdxsrd	PavtOverlay_px	Pavement Overlay on Cross Sections - Component Property	1	0 / Continuous	2
X	rdxsrd	PavtOverlay1_px	Pavement Overlay on Cross Sections - Component Property	14	0 / Continuous	2
X	rdxsrd	PavtOverlay2_px	Pavement Overlay on Cross Sections - Component Property	7	0 / Continuous	2
X	rdxsrd	PavtStabilization_px	Stabilization on Cross Sections	5	2 / DGN2	2
	rdxsrd	PayItem_dp	Pay Item Number Label Elements	4	0 / Continuous	2
	rdxsrd	PipeCulvert_ep	Pipe Culvert (Existing)	10	3 / DGN3	1
X	rdxsrd	PipeCulvert_ex	Pipe Culvert in Cross Sections (Existing)	10	3 / DGN3	1
X	rdxsrd	PipeCulvert_pr	Pipe Culvert in Profile	10	0 / Continuous	2

Critical	Rule	Level Name	Level Description	ByLevel Color	ByLevelStyle / Linetype	ByLevel Weight
X	rdxsrd	PipeCulvert_px	Pipe Culvert on Cross Section View	10	0 / Continuous	2
X	rdxsrd	PlotBorder_dp	Plot Border	3	0 / Continuous	0
	rdxsrd	PointLocator_ep	Point Locator Symbol (Existing)	4	0 / Continuous	0
X	rdxsrd	Pond_px	Pond Lines on Cross Sections	2	0 / Continuous	2
X	rdxsrd	PropertyLine_ep	Property Lines (Existing)	3	0 / Continuous	0
X	rdxsrd	PvtAnalysisCrown_px	Pavement Analysis Crowning on Cross Sections - Component Property	7	0 / Continuous	1
X	rdxsrd	PvtAnalysisFail_px	Pavement Analysis Failure on Cross Sections - Component Property	3	0 / Continuous	1
X	rdxsrd	PvtAnalysisMax_px	Pavement Analysis Acceptable Maximum Range on Cross Sections - Component Property	5	0 / Continuous	1
X	rdxsrd	PvtAnalysisMin_px	Pavement Analysis Acceptable Minimum Range on Cross Sections - Component Property	4	0 / Continuous	1
X	rdxsrd	PvtAnalysisOptiml_px	Pavement Analysis Optimal on Cross Sections - Component Property	2	0 / Continuous	1
X	rdxsrd	Railing_px	Railing Components and Cross Sections Shapes	9	0 / Continuous	2
	rdxsrd	ReferencePt_dp	Survey and Construction Reference Point Details and Elements	4	0 / Continuous	2
	rdxsrd	RegionBdry_dp	Boundary Line for Regions in Corridor Design (For AutoCAD Use)	0	0 / Continuous	0
X	rdxsrd	RipRap_px	Rip Rap, Rubble on Cross Sections	4	1 / DGN1	2
X	rdxsrd	RumbleStrip1	Rumble Strips Continuous Array	0	PM-RumbleSolid	2
X	rdxsrd	RumbleStrip2	Rumble Strips Skip Array	0	PM-RumbleSkip	2
X	rdxsrd	RWLine	Right of Way Lines	4	RW-Proposed	2
X	rdxsrd	RWLine_ep	Right of Way Lines (Existing)	3	RW-Existing	1
X	rdxsrd	RWLine_ex	Right of Way Lines on Cross Sections (Existing)	3	RW-Existing	1
X	rdxsrd	RWLine_px	Right of Way Lines on Cross Sections	4	RW-Proposed	2
X	rdxsrd	SanitaryFM_ex	Force Main Lines on Cross Sections (Existing)	2	2 / DGN2	1
X	rdxsrd	SanitaryFM_px	Force Main Lines on Cross Sections	2	0 / Continuous	1
X	rdxsrd	SanitarySewer_ex	Sanitary Sewer on Cross Sections (Existing)	2	2 / DGN2	0
X	rdxsrd	SanitarySewer_px	Sanitary Sewer on Cross Sections	2	0 / Continuous	1
X	rdxsrd	SanitarySewerEff_ex	Sanitary Sewer Effluent on Cross Sections (Existing)	5	0 / Continuous	0
X	rdxsrd	SanitarySewerEff_px	Sanitary Sewer Effluent on Cross Sections	5	0 / Continuous	0
	rdxsrd	Scratch1_dp	Scratch Level for Temporary or Informational Items	4	0 / Continuous	0
	rdxsrd	Scratch2_dp	Scratch Level for Temporary or Informational Items	5	0 / Continuous	0
	rdxsrd	ScratchEle_dp	Scratch Level for Draft Elements, Temporary Elements, Etc. (DO NOT PLOT)	3	0 / Continuous	0
	rdxsrd	ScratchEle2_dp	Scratch Level for Draft Elements, Temporary Elements, Etc. (DO NOT PLOT)	4	0 / Continuous	0
	rdxsrd	SheetBorder_dp	Sheet Border	1	0 / Continuous	4
	rdxsrd	SheetLines_dp	Sheet Lines	1	0 / Continuous	2
	rdxsrd	SheetLinesMisc1_dp	Sheet Lines	1	0 / Continuous	0
	rdxsrd	SheetLinesMisc2_dp	Sheet Lines	2	0 / Continuous	2
	rdxsrd	SheetLinesMisc3_dp	Sheet Lines	3	0 / Continuous	2
	rdxsrd	SheetLinesMisc4_dp	Sheet Lines	4	0 / Continuous	2
X	rdxsrd	ShldrBase_px	Shoulder Base on Cross Sections	3	0 / Continuous	2
X	rdxsrd	ShldrMilling_px	Shoulder Milling on Cross Sections - Component Property	7	0 / Continuous	2
X	rdxsrd	ShldrOverbuild_px	Shoulder Overbuild on Cross Sections - Component Property	4	0 / Continuous	1
X	rdxsrd	ShldrOverlay_px	Shoulder Overlay on Cross Sections - Component Property	1	0 / Continuous	1
X	rdxsrd	ShldrPaved_px	Shoulder Lines on Cross Sections (Paved)	1	0 / Continuous	2
X	rdxsrd	ShldrUnpaved_px	Shoulder Lines on Cross Sections (Unpaved)	2	0 / Continuous	2
X	rdxsrd	Sidewalk_ex	Sidewalk Elements on Cross Sections (Existing)	0	2 / DGN2	1
X	rdxsrd	Sidewalk_px	Sidewalk Elements on Cross Sections	0	0 / Continuous	2
	rdxsrd	SidewalkBack_er	Back of Sidewalk Line Profile (Existing)	2	2 / DGN2	1
	rdxsrd	SidewalkBack_pr	Back of Sidewalk Line Profile	5	0 / Continuous	2

Critical	Rule	Level Name	Level Description	ByLevel Color	ByLevelStyle / Linetype	ByLevel Weight
X	rdxsrd	SidewalkBase_px	Sidewalk Subgrade on Cross Sections	3	0 / Continuous	2
X	rdxsrd	Slopes_px	Slope Lines on Cross Sections	9	0 / Continuous	2
X	rdxsrd	SoilBoxes_px	Soil Boxes and Borings on Cross Sections	4	0 / Continuous	1
	rdxsrd	SpecialDetails_px	Special Details on Cross Sections	6	0 / Continuous	1
	rdxsrd	StationTicL_dp	Station Tic Marks (Large) and Text	0	0 / Continuous	2
	rdxsrd	StationTicS_dp	Station Tic Marks (Small) and Text	0	0 / Continuous	2
X	rdxsrd	StreetLights_px	Street Lights on Cross Sections	3	0 / Continuous	1
	rdxsrd	Structure_px	Signal and Sign Structures on Cross Sections	0	0 / Continuous	2
X	rdxsrd	SubDsgn_px	Sub Design on Cross Sections Including Sub-base	4	0 / Continuous	1
X	rdxsrd	Subsoil_px	Subsoil Or Undercut on Cross Sections	4	0 / Continuous	2
X	rdxsrd	SubsoilFinal_px	Subsoil Final for Multiline on Cross Sections	18	0 / Continuous	1
X	rdxsrd	SubsoilProp_px	Subsoil Proposed for Multiline on Cross Sections	8	0 / Continuous	1
	rdxsrd	SumBoxBorder_dp	Summary Boxes Borders	4	0 / Continuous	3
	rdxsrd	SumBoxLines_dp	Summary Boxes Lines and Miscellaneous Items	4	0 / Continuous	1
	rdxsrd	SumBoxLinesMin_dp	Summary Boxes Lines Minor Line and Miscellaneous Items	4	0 / Continuous	0
	rdxsrd	Tables_dp	Data Tables and All Autodesk Tables	0	0 / Continuous	1
X	rdxsrd	TeleBur_ex	Telephone on Cross Sections (Buried) (Miscellaneous) (Existing)	6	2 / DGN2	1
X	rdxsrd	TeleBur_px	Telephone on Cross Sections (Buried) (Miscellaneous)	6	0 / Continuous	1
X	rdxsrd	TemplateBottom_px	Bottom of Template for Multiline on Cross Sections	6	0 / Continuous	1
X	rdxsrd	TemplateFinal_px	Final Template for Multiline on Cross Sections	2	0 / Continuous	1
X	rdxsrd	TemplateTop_px	Top of Template for Multiline on Cross Sections	7	0 / Continuous	1
X	rdxsrd	TerrainLine_ex	Ground Line for Multiline on Cross Sections (Existing)	5	0 / Continuous	1
	rdxsrd	TextAlert	Text - Alert Label to Highlight a Problem	3	0 / Continuous	2
	rdxsrd	TextBLStation	Text - B/L Station and Tics	0	0 / Continuous	2
	rdxsrd	TextConstEle	Text - Construction Element	0	0 / Continuous	1
	rdxsrd	TextCurveData	Text - Curve Data Note	0	0 / Continuous	2
	rdxsrd	TextDetails	Text - Detail Notes	4	0 / Continuous	2
	rdxsrd	TextDrainInvElev_ep	Text - Drainage Invert Elevation (Existing)	0	0 / Continuous	1
	rdxsrd	TextDrainLabel_ep	Text - Drainage (Existing)	0	0 / Continuous	1
	rdxsrd	TextElevLabel	Text - Elevation Labels	4	0 / Continuous	0
	rdxsrd	TextGeotech	Text - Soil Borings and Labels	0	0 / Continuous	2
	rdxsrd	TextLabel	Text - Label	0	0 / Continuous	2
	rdxsrd	TextLandscape	Text - Landscape Labels	0	0 / Continuous	1
	rdxsrd	TextMajor	Text - Major	0	0 / Continuous	5
	rdxsrd	TextMinor	Text - Minor	0	0 / Continuous	0
	rdxsrd	TextMisc	Text - Miscellaneous	0	0 / Continuous	1
	rdxsrd	TextNotes	Text - Notes	4	0 / Continuous	1
	rdxsrd	TextProfLabel	Text - Profile, Horizontal and Vertical Axis Labels	0	0 / Continuous	2
	rdxsrd	TextProjLabel	Text - Begin and End Project Label with Leader Lines	1	0 / Continuous	2
	rdxsrd	TextPtLabel	Text - Point Labels	4	0 / Continuous	0
	rdxsrd	TextShtNo	Text - Sheet Number	0	0 / Continuous	2
	rdxsrd	TextSubUtilLabel_ep	Text - Subsurface Utilities (Existing)	0	0 / Continuous	1
	rdxsrd	TextSurveyLabel	Text - Survey Labels	0	0 / Continuous	0
	rdxsrd	TextTables	Text - Key Sheet Indexes and Table Data	4	0 / Continuous	2
	rdxsrd	TextTitle	Text - Title	0	0 / Continuous	3
	rdxsrd	TextTopoLabel_ep	Text - Topography (Existing)	0	0 / Continuous	1

Critical	Rule	Level Name	Level Description	ByLevel Color	ByLevelStyle / Linetype	ByLevel Weight
	rdxsrd	TextUtilLabel_ep	Text - Utilities (Existing)	0	0 / Continuous	1
	rdxsrd	TextXSBL_dp	Text - Cross Section Baseline Labels	0	0 / Continuous	2
	rdxsrd	TextXSDrain_ex	Text - Cross Section Drainage Labels (Existing)	10	0 / Continuous	2
	rdxsrd	TextXSDrain_px	Text - Cross Section Drainage Labels	10	0 / Continuous	2
	rdxsrd	TextXSElev	Text - Cross Section Elevations	2	0 / Continuous	1
	rdxsrd	TextXSElev_ex	Text - Cross Section Elevations (Existing)	2	0 / Continuous	1
	rdxsrd	TextXSElev_px	Text - Cross Section Elevations	0	0 / Continuous	1
	rdxsrd	TextXSGPKPts_dp	Text - Cross Section Points Labels	4	0 / Continuous	0
	rdxsrd	TextXSNotes_dp	Text - Cross Section Notes	0	0 / Continuous	2
	rdxsrd	TextXSSlope_dp	Text - Cross Section Slope Labels (rise:run format)	0	0 / Continuous	2
	rdxsrd	TextXSSlopePvt_dp	Text - Cross Section Pavement Slope Labels	0	0 / Continuous	2
X	rdxsrd	TrafSeparator_ex	Traffic Separator on Cross Sections (All Types) (Existing)	6	2 / DGN2	1
X	rdxsrd	TrafSeparator_px	Traffic Separator on Cross Sections (All Types)	6	0 / Continuous	2
X	rdxsrd	TrafSeparatorBase_px	Traffic Separator Subgrade on Cross Sections	3	0 / Continuous	2
	rdxsrd	TypicalMisc	Typical Items (Miscellaneous)	0	0 / Continuous	2
	rdxsrd	UtilsMisc_ex	Utility Items on Cross Sections (Miscellaneous) (Existing)	8	2 / DGN2	1
	rdxsrd	UtilsMisc_px	Utility Items on Cross Sections (Miscellaneous)	8	0 / Continuous	1
	rdxsrd	Vehicle	Vehicle for Calculating Turning Radius	7	0 / Continuous	2
	rdxsrd	Viewport	Viewport (For AutoCAD Use)	3	0 / Continuous	0
	rdxsrd	VoidArea_dx	Void Area on Cross Sections	1	0 / Continuous	0
X	rdxsrd	WallBarrier_ex	Barrier Wall on Cross Section (Existing)	6	3 / DGN3	1
X	rdxsrd	WallBarrier_px	Barrier Wall on Cross Section	6	0 / Continuous	2
X	rdxsrd	WallFooter_px	Wall Footer (Concrete) on Cross Sections - Component Symbolology/Material on All Wall Footers/Leveling Pads	2	0 / Continuous	1
X	rdxsrd	WallGravBase_px	Gravity Wall Subgrade on Cross Sections	3	0 / Continuous	2
X	rdxsrd	WallGravity_px	Gravity Wall on Cross Sections	11	0 / Continuous	2
X	rdxsrd	WallMedianBase_px	Median Wall Subgrade on Cross Sections	3	0 / Continuous	2
X	rdxsrd	WallRetain_px	Retaining Walls on Cross Sections	6	0 / Continuous	1
X	rdxsrd	WallShldrBase_px	Shoulder Wall Subgrade on Cross Sections	3	0 / Continuous	2
X	rdxsrd	Water_ex	Water on Cross Sections (Existing)	1	2 / DGN2	1
X	rdxsrd	Water_px	Water on Cross Sections	1	0 / Continuous	1
X	rdxsrd	WaterNP_ex	Raw Water Pipes on Cross Sections (Existing)	5	0 / Continuous	1
X	rdxsrd	WaterNP_px	Raw Water Pipes on Cross Sections	5	0 / Continuous	1
	rdxsrd	Wetland_ex	Wetland Boundary on Cross Sections (Existing)	2	RD-Wetland-Existing	1
	rdxsrd	WetlandEdge_ep	Edge of Mangrove, Wetlands (Marsh or Swamp) (Existing)	2	RD-Wetland-Existing	0
	rdxsrd	Xreference01_dp	Reference Files (For AutoCAD Use)	0	0 / Continuous	1
	rdxsrd	Xreference02_dp	Reference Files (For AutoCAD Use)	0	0 / Continuous	1
	rdxsrd	Xreference03_dp	Reference Files (For AutoCAD Use)	0	0 / Continuous	1
	rdxsrd	Xreference04_dp	Reference Files (For AutoCAD Use)	0	0 / Continuous	1
X	rdxsrd	XSBaseTop_px	Cross Section Top of Base	3	0 / Continuous	2
	rdxsrd	XSCell	GEOPAK Cross Section Cell/Block and Profile Cell/Block	8	0 / Continuous	1
X	rdxsrd	XSExtendGrdLine_ex	Cross Section Extend Ground Lines (Existing)	21	2 / DGN2	1
X	rdxsrd	XSGrdLine_ex	Cross Section Ground Lines (Existing)	2	2 / DGN2	1
X	rdxsrd	XSGrdLine_px	Cross Section Roadway Ground Lines	1	0 / Continuous	2
	rdxsrd	XSMisc_ex	Cross Section Roadway Items (Miscellaneous) (Existing)	4	3 / DGN3	1
	rdxsrd	XSMisc_px	Cross Section Items (Miscellaneous)	0	0 / Continuous	2
	rdxsrd	XSPt_ep	Cross Section Point, Station (Existing)	2	1 / DGN1	0

Critical	Rule	Level Name	Level Description	ByLevel Color	ByLevelStyle / Linetype	ByLevel Weight
	rdxsrd	XSShapeDep01_dp	Cross Section Shape Dependent	11	0 / Continuous	2
	rdxsrd	XSShapeDep02_dp	Cross Section Shape Dependent	12	0 / Continuous	2
	rdxsrd	XSShapeDep03_dp	Cross Section Shape Dependent	13	0 / Continuous	2
	rdxsrd	XSShapeDep04_dp	Cross Section Shape Dependent	14	0 / Continuous	2
	rdxsrd	XSShapeDep05_dp	Cross Section Shape Dependent	15	0 / Continuous	2
	rdxsrd	XSShapeDep06_dp	Cross Section Shape Dependent	16	0 / Continuous	2
	rdxsrd	XSShapeDep07_dp	Cross Section Shape Dependent	17	0 / Continuous	2
	rdxsrd	XSShapeDep08_dp	Cross Section Shape Dependent	18	0 / Continuous	2
	rdxsrd	XSShapeDep09_dp	Cross Section Shape Dependent	19	0 / Continuous	2
	rdxsrd	XSShapeDep10_dp	Cross Section Shape Dependent	20	0 / Continuous	2
	rdxsrd	XSShapeIndep01_dp	Cross Section Shape Independent	1	0 / Continuous	2
	rdxsrd	XSShapeIndep02_dp	Cross Section Shape Independent	2	0 / Continuous	2
	rdxsrd	XSShapeIndep03_dp	Cross Section Shape Independent	3	0 / Continuous	2
	rdxsrd	XSShapeIndep04_dp	Cross Section Shape Independent	4	0 / Continuous	2
	rdxsrd	XSShapeIndep05_dp	Cross Section Shape Independent	5	0 / Continuous	2
	rdxsrd	XSShapeIndep06_dp	Cross Section Shape Independent	6	0 / Continuous	2
	rdxsrd	XSShapeIndep07_dp	Cross Section Shape Independent	7	0 / Continuous	2
	rdxsrd	XSShapeIndep08_dp	Cross Section Shape Independent	8	0 / Continuous	2
	rdxsrd	XSShapeIndep09_dp	Cross Section Shape Independent	9	0 / Continuous	2
	rdxsrd	XSShapeIndep10_dp	Cross Section Shape Independent	10	0 / Continuous	2
X	rdxsrd	XSTypical_px	Cross Section Roadway Pavement Typical	1	0 / Continuous	2

## RDXSSP - Signing and Pavement Cross Section

Critical	Rule	Level Name	Level Description	ByLevel Color	ByLevelStyle / Linetype	ByLevel Weight
	rdxssp	ActivePointCell_dp	Active Point Cell	4	0 / Continuous	10
	rdxssp	AdhocPoint_dp	Adhoc Points Placed by SheetInfo	0	4 / DGN4	0
	rdxssp	BaselineSurvey	Baseline Survey	0	0 / Continuous	2
X	rdxssp	Berm_px	Berm (Top, Front, or Back) on Cross Sections	10	0 / Continuous	2
X	rdxssp	Bridge_px	Bridge Component on Cross Sections - Component Property	0	0 / Continuous	2
X	rdxssp	CandG_ex	Curb and Gutter on Cross Sections (All Types) (Existing)	4	2 / DGN2	1
X	rdxssp	CandG_px	Curb and Gutter on Cross Sections (All Types)	4	0 / Continuous	2
X	rdxssp	CandGBase_px	Curb and Gutter Base on Cross Sections	3	0 / Continuous	1
X	rdxssp	CATVBur_ex	Cable TV and Miscellaneous on Cross Sections (Buried) (Existing)	6	2 / DGN2	1
X	rdxssp	CATVBur_px	Cable TV and Miscellaneous on Cross Sections (Buried)	6	0 / Continuous	1
	rdxssp	CLConst_dp	Center Line of Construction	0	0 / Continuous	2
	rdxssp	Cloud_dp	Construction Cloud	7	0 / Continuous	2
	rdxssp	COGO_dp	COGO Information	3	0 / Continuous	1
X	rdxssp	Concrete_px	Concrete Boundary Lines on Cross Sections	0	0 / Continuous	2
X	rdxssp	Conduit_ex	Conduit and Encasements on Cross Sections (Existing)	3	2 / DGN2	1
X	rdxssp	Conduit_px	Conduit and Encasements on Cross Sections	3	0 / Continuous	1
X	rdxssp	ConduitAG	Conduit (Above Ground)	4	SG-ConduitAG-Proposed	1
X	rdxssp	ConduitBM	Conduit – Bridge Mount	5	SG-ConduitBM-Proposed	1
X	rdxssp	ConduitDB	Conduit – Directional Bore	2	SG-ConduitDB-Proposed	1
X	rdxssp	ConduitJB	Conduit – Jack & Bore Under Rail	3	SG-ConduitJB-Proposed	1



Critical	Rule	Level Name	Level Description	ByLevel Color	ByLevelStyle / Linetype	ByLevel Weight
X	rdxssp	ConduitOT	Conduit – Open Trench	1	SG-ConduitOT-Proposed	1
	rdxssp	ConstArea_dp	Construction Area Crosshatch	0	0 / Continuous	1
	rdxssp	ConstLimits	Construction Limits	3	RW-LimitsofConst	2
	rdxssp	ConstLines	Construction Lines and References	1	0 / Continuous	0
	rdxssp	ConstLines_pm	Construction Lines	4	0 / Continuous	0
X	rdxssp	CrossWalk1	Emphasis Crosswalk 6ft High	0	PM-Stripe-6' Crosswalk	4
X	rdxssp	CrossWalk2	Emphasis Crosswalk 10ft High	0	PM-Stripe-10' Crosswalk	4
	rdxssp	CurveData_dp	Curve and Coordinate Data Elements Including PC, PT, PI Symbols	4	0 / Continuous	2
	rdxssp	CurveDataLabel_dp	Curve Data Labels PC,PI, PT	0	0 / Continuous	2
X	rdxssp	Delineator	Delineators (All Types)	4	0 / Continuous	1
	rdxssp	DimLines_dp	Dimension Lines, Corresponding Terminators, Equation Lines	0	0 / Continuous	1
X	rdxssp	DirArrowsPavt	Pavement Marking Directional Arrows	0	0 / Continuous	1
X	rdxssp	Ditch_px	Ditch Top on Cross Sections	7	0 / Continuous	2
X	rdxssp	DitchBot_px	Ditch Bottom on Cross Sections	10	0 / Continuous	2
X	rdxssp	DitchPavt_px	Ditch Pavement on Cross Sections	3	0 / Continuous	3
	rdxssp	DrainAlert_px	Alert Symbology for Structural Elements on Cross Sections	3	0 / Continuous	2
	rdxssp	DrainMisc_ex	Drainage Elements on Cross Sections (All) (Miscellaneous) (Existing)	10	3 / DGN3	1
X	rdxssp	DrainStruct_ex	Drainage Structures on Cross Sections (All) (Existing)	10	3 / DGN3	1
X	rdxssp	DrainStruct_px	Drainage Structures and Elements on Cross Sections (Miscellaneous)	10	0 / Continuous	2
X	rdxssp	Driveway_ex	Driveway Lines on Cross Sections (Existing)	7	2 / DGN2	2
X	rdxssp	Driveway_px	Driveway Lines on Cross Sections	7	0 / Continuous	2
X	rdxssp	DrivewayBase_px	Driveway Subgrade on Cross Sections	3	0 / Continuous	2
	rdxssp	Earthwork1_px	Earthwork (Color 0) on Cross Sections	0	0 / Continuous	1
	rdxssp	Earthwork2_px	Earthwork (Color 1) on Cross Sections	1	0 / Continuous	1
	rdxssp	Earthwork3_px	Earthwork (Color 2) on Cross Sections	2	0 / Continuous	1
	rdxssp	Earthwork4_px	Earthwork (Color 3) on Cross Sections	3	0 / Continuous	1
	rdxssp	Earthwork5_px	Earthwork (Color 4) on Cross Sections	4	0 / Continuous	1
X	rdxssp	EaseLicLine	Easement License Agreement Line	5	6 / DGN6	0
X	rdxssp	EaseLine_ep	Easement Lines (Existing)	1	RW-Easement	1
X	rdxssp	EasePerLine_px	Easement Lines Perpetual on Cross Sections	4	RW-PerpetualEasement	1
X	rdxssp	EaseTempLine_px	Easement Lines Temporary on Cross Sections	6	RW-TemporaryEasement	0
X	rdxssp	ElecBur_ex	Electrical on Cross Sections (Buried) (Existing)	3	2 / DGN2	1
X	rdxssp	ElecBur_px	Electrical on Cross Sections (Buried)	3	0 / Continuous	1
X	rdxssp	Endwall_px	Endwall on Cross Sections	10	0 / Continuous	2
	rdxssp	ExcavationLimits_dp	Excavation Limits on Cross Sections	0	0 / Continuous	1
	rdxssp	Fence_ex	Fence Lines on Cross Sections (Existing)	6	3 / DGN3	1
X	rdxssp	Fence_px	Fence Lines on Cross Sections	6	RD-Fence	2
X	rdxssp	FES_px	Flared End Sections on Cross Sections	10	0 / Continuous	2
X	rdxssp	FOCBur_ex	Fiber Optics Cable (Buried) on Cross Sections (Buried) (Existing)	6	2 / DGN2	1
X	rdxssp	FOCBur_px	Fiber Optics Cable (Buried) on Cross Sections (Buried)	6	0 / Continuous	1
X	rdxssp	FOEElecBur_ex	Fiber Optics Electrical on Cross Sections (Buried) (Existing)	3	2 / DGN2	1
X	rdxssp	FOEElecBur_px	Fiber Optics Electrical on Cross Sections (Buried)	3	0 / Continuous	1
X	rdxssp	FOTBur_ex	Fiber Optics Telephone on Cross Sections (Buried) (Existing)	6	2 / DGN2	1
X	rdxssp	FOTBur_px	Fiber Optics Telephone on Cross Sections (Buried)	6	0 / Continuous	1
X	rdxssp	Gas_ex	Gas Pipe and Fittings on Cross Sections (Miscellaneous) (Existing)	4	2 / DGN2	1
X	rdxssp	Gas_px	Gas Pipe and Fittings on Cross Sections (Miscellaneous)	4	0 / Continuous	1
	rdxssp	GeotechFillPatt1	Geotechnical Fill Pattern - (Earth, Wood, Muck, Concrete, Rock, Riprap) as Defined in Project	3	0 / Continuous	0

Critical	Rule	Level Name	Level Description	ByLevel Color	ByLevelStyle / Linetype	ByLevel Weight
	rdxssp	GeotechFillPatt1_px	Geotechnical Fill Pattern on Cross Sections (Earth, Wood, Muck, Concrete, Rock, Riprap) as Defined in Project	3	0 / Continuous	0
	rdxssp	GeotechFillPatt2	Geotechnical Fill Pattern - Clay, Sand	0	1 / DGN1	0
	rdxssp	GeotechFillPatt2_px	Geotechnical Fill Pattern on Cross Sections - Clay, Sand	0	1 / DGN1	0
	rdxssp	GeotechFillPatt3	Geotechnical Fill Pattern - Shell	3	1 / DGN1	0
	rdxssp	GeotechFillPatt3_px	Geotechnical Fill Pattern on Cross Sections - Shell	3	1 / DGN1	0
	rdxssp	GeotechFillPatt4	Geotechnical Fill Pattern - sand	4	0 / Continuous	0
	rdxssp	GeotechFillPatt4_px	Geotechnical Fill Pattern on Cross Sections - Sand	4	0 / Continuous	0
	rdxssp	GeotechFillPatt5	Geotechnical Fill Pattern - coquina	1	0 / Continuous	1
	rdxssp	GeotechFillPatt5_px	Geotechnical Fill Pattern on Cross Sections - Coquina	1	0 / Continuous	1
	rdxssp	GeotechFillPatt6	Geotechnical Fill Pattern - limestone	2	0 / Continuous	0
	rdxssp	GeotechFillPatt6_px	Geotechnical Fill Pattern on Cross Sections - Limestone	2	0 / Continuous	0
	rdxssp	GeotechFillPatt7	Geotechnical Fill Pattern - gravel	6	0 / Continuous	0
	rdxssp	GeotechFillPatt7_px	Geotechnical Fill Pattern on Cross Sections - Gravel	6	0 / Continuous	0
	rdxssp	GeotechFillPatt8	Geotechnical Fill Pattern - silt	0	0 / Continuous	1
	rdxssp	GeotechFillPatt8_px	Geotechnical Fill Pattern on Cross Sections - Silt	0	0 / Continuous	1
	rdxssp	GeotechMisc	Geotechnical Elements (Miscellaneous)	0	0 / Continuous	1
	rdxssp	GridMaj_dp	Grid Lines Major in Profile and Cross Section	3	0 / Continuous	1
	rdxssp	GridMin_dp	Grid Lines Minor in Profile and Cross Section	0	0 / Continuous	0
	rdxssp	GridMinG_dp	Grid Lines Minor Sub 2 on Cross Section Sheets	20	0 / Continuous	0
	rdxssp	GridMinSub_dp	Grid Lines Minor Sub on Cross Section Sheets	20	0 / Continuous	0
	rdxssp	GSBWFill	GuidSign Black and White Fill Level for GuidSign Cells	0	0 / Continuous	1
	rdxssp	GSColorFill	GuidSign Color Fill Level for GuidSign Cells	2	0 / Continuous	1
	rdxssp	GSDims	GuidSign Dimensions	0	0 / Continuous	1
	rdxssp	GSOuline	GuidSign Outline Level for GuidSign Cells	0	0 / Continuous	2
	rdxssp	GSSign	GuidSign Panel and Tag	7	0 / Continuous	0
X	rdxssp	Guardrail_ex	Guardrail Lines on Cross Sections (Existing)	0	2 / DGN2	2
X	rdxssp	GuardrailPanel_px	Guardrail Component Property on Cross Sections for 3D Guardrail Panels	11	0 / Continuous	1
X	rdxssp	GuardrailPost_px	Guardrail Component Property on Cross Sections for 3D Guardrail Posts	10	0 / Continuous	0
	rdxssp	ImageAttachment_dp	Image Attachments	0	0 / Continuous	0
X	rdxssp	Inlet_px	Inlets on Cross Sections	10	0 / Continuous	2
X	rdxssp	InletBottom_px	Inlet Bottom on Cross Sections (All Types)	10	0 / Continuous	2
X	rdxssp	InterconCable	Cable Interconnect	1	SG-InterconCable-Proposed	1
X	rdxssp	InterconCable_ep	Interconnect Cable (Existing)	1	SG-InterconCable-Existing	0
X	rdxssp	JunctBoxA	Junction Boxes (Aerial)	3	0 / Continuous	1
X	rdxssp	JunctBoxA_ep	Junction Boxes (Aerial) (Existing)	3	1 / DGN1	0
	rdxssp	KeyShtMisc	Key Sheet Items (Miscellaneous)	0	0 / Continuous	2
	rdxssp	LaneDirArrow	Lane Directional Arrow	0	0 / Continuous	1
X	rdxssp	LARWLine_ex	Limited Access Right of Way Lines on Cross Sections (Existing)	4	RW-LimitedAccess-Existing	1
X	rdxssp	LARWLine_px	Limited Access Right of Way Lines on Cross Sections	4	RW-LimitedAccess-Proposed	2
X	rdxssp	LateralLimits_px	Lateral Limits on Cross Sections	6	0 / Continuous	2
	rdxssp	LeaderLine_dp	Leader Line and Terminator with Text	0	0 / Continuous	1
	rdxssp	LightingMisc	Lighting Items (Miscellaneous)	4	0 / Continuous	2
X	rdxssp	LightingSP	Lighting Service Points	0	0 / Continuous	1
X	rdxssp	LoadCenter	Load Center	2	0 / Continuous	1
X	rdxssp	LoadCenter_ep	Load Center (Existing)	2	5 / DGN5	0
	rdxssp	Logo_dp	Consultant Engineer of Record Logo	0	0 / Continuous	1
X	rdxssp	Luminaire	Luminaires (Decorative - All Types)	2	0 / Continuous	1



Critical	Rule	Level Name	Level Description	ByLevel Color	ByLevelStyle / Linetype	ByLevel Weight
	rdxssp	Manhole_ex	Manhole on Cross Sections (Existing)	10	3 / DGN3	2
X	rdxssp	Manhole_px	Manhole on Cross Sections	10	0 / Continuous	2
X	rdxssp	MES_px	Mitered End Section on Cross Sections	10	0 / Continuous	2
X	rdxssp	MetalButtons	Metal Buttons	0	0 / Continuous	2
	rdxssp	Miscellaneous0	Undefined Proposed Item - Color Blue Weight 0	1	0 / Continuous	0
	rdxssp	Miscellaneous1	Undefined Proposed Item - Color Blue Weight 1	1	0 / Continuous	1
	rdxssp	Miscellaneous2	Undefined Proposed Item - Color Blue Weight 2	1	0 / Continuous	2
	rdxssp	Miscellaneous3	Undefined Proposed Item - Color Green Weight 0	2	0 / Continuous	0
	rdxssp	Miscellaneous4	Undefined Proposed Item - Color Green Weight 1	2	0 / Continuous	1
	rdxssp	Miscellaneous5	Undefined Proposed Item - Color Green Weight 2	2	0 / Continuous	2
	rdxssp	Miscellaneous6	Undefined Proposed Item - Color Red Weight 0	3	0 / Continuous	0
	rdxssp	Miscellaneous7	Undefined Proposed Item - Color Red Weight 1	3	0 / Continuous	1
	rdxssp	Miscellaneous8	Undefined Proposed Item - Color Red Weight 2	3	0 / Continuous	2
	rdxssp	Miscellaneous9	Undefined Proposed Item - Color Red Weight 3	3	0 / Continuous	3
	rdxssp	NonPlottingEle_dp	Non-Plotting Items - Construction Elements, Type 66 Elements, Etc.	4	0 / Continuous	0
	rdxssp	NorthArw_dp	North Arrows	0	0 / Continuous	2
X	rdxssp	ObjectMarker	Object and Reflective Markers	3	0 / Continuous	1
X	rdxssp	OverheadSign	Overhead Sign Panels	0	0 / Continuous	2
X	rdxssp	OverheadSign_ep	Overhead Sign Panels (Existing)	0	3 / DGN3	1
X	rdxssp	OverheadStr	Mast Arm, Truss Assemblies, Signal Arms and Supports	0	0 / Continuous	2
X	rdxssp	OverheadStr_ep	Mast Arm, Truss Assemblies, Signal Arms and Supports (Existing)	0	3 / DGN3	1
	rdxssp	Patternlines_ep	Cross Section Chain (Existing)	2	1 / DGN1	0
	rdxssp	PatternLines1_dp	Pattern Lines on Cross Sections and All Autodesk (Civil 3D) Tables	3	0 / Continuous	2
	rdxssp	PatternLines2_dp	Pattern Lines on Cross Sections Alternate for Side Streets, CriticalCross Sections or Drainage Structures	4	0 / Continuous	2
	rdxssp	PatternLines3_dp	Pattern Lines on Cross Sections Alternate for Side Streets, CriticalCross Sections or Drainage Structures	5	0 / Continuous	2
X	rdxssp	PavedMedianBase_px	Median Subgrade on Cross Sections (Paved)	3	0 / Continuous	2
	rdxssp	PavtAsphalt_ep	Asphalt Pavement Edge (Existing)	0	3 / DGN3	1
X	rdxssp	PavtAsphalt_px	Asphalt Pavement on Cross Sections and Components in Models	1	0 / Continuous	2
X	rdxssp	PavtBase_ex	Base Material on Cross Sections (All Types) (Existing)	3	3 / DGN3	1
X	rdxssp	PavtBase_px	Base Material on Cross Sections (All Types)	3	0 / Continuous	2
X	rdxssp	PavtConcrete_px	Concrete Pavement on Cross Sections and Components in Models	0	0 / Continuous	2
X	rdxssp	PavtMessage	Pavement Message (All Types)	0	0 / Continuous	1
X	rdxssp	PavtMessage_ep	Pavement Message (All Types) (Existing)	0	2 / DGN2	0
X	rdxssp	PavtMilling_px	Asphalt Milling Lines on Cross Sections	7	0 / Continuous	2
X	rdxssp	PavtMisc_px	Pavement on Cross Sections (Miscellaneous)	1	0 / Continuous	2
X	rdxssp	PavtOverbuild_px	Pavement Overbuild Areas on Cross Sections - Component Property	4	0 / Continuous	2
X	rdxssp	PavtOverlay_px	Pavement Overlay on Cross Sections - Component Property	1	0 / Continuous	2
X	rdxssp	PavtOverlay1_px	Pavement Overlay on Cross Sections - Component Property	14	0 / Continuous	2
X	rdxssp	PavtOverlay2_px	Pavement Overlay on Cross Sections - Component Property	7	0 / Continuous	2
X	rdxssp	PavtStabilization_px	Stabilization on Cross Sections	5	2 / DGN2	2
	rdxssp	PayItem_dp	Pay Item Number Label Elements	4	0 / Continuous	2
X	rdxssp	PipeCulvert_ep	Pipe Culvert (Existing)	10	3 / DGN3	1
X	rdxssp	PipeCulvert_ex	Pipe Culvert in Cross Sections (Existing)	10	3 / DGN3	1
X	rdxssp	PipeCulvert_pr	Pipe Culvert in Profile	10	0 / Continuous	2
X	rdxssp	PipeCulvert_px	Pipe Culvert on Cross Section View	10	0 / Continuous	2
X	rdxssp	PlotBorder_dp	Plot Border	3	0 / Continuous	0
X	rdxssp	PMCeramic	Pavement Markers Ceramic	0	0 / Continuous	1

Critical	Rule	Level Name	Level Description	ByLevel Color	ByLevelStyle / Linetype	ByLevel Weight
	rdxssp	PMMisc	Pavement Marking Items (Miscellaneous)	0	0 / Continuous	2
X	rdxssp	PMStripe(10-10-20)	Pavement Marking 10/10/20 Skip Traffic Stripe 6in Contrast	0	PM-Stripe-10' 20'Skip / PM-Stripe-SKIP 10-10-20	2
X	rdxssp	PMStripe(2-2-2)	Pavement Marking 2/2/2 Skip Traffic Stripe 6in Contrast	0	PM-Stripe-2' 2'Skip / PM-Stripe-SKIP 2-2-2	2
X	rdxssp	PMStripe12B	Pavement Marking Traffic Stripe 12in Black	3	0 / Continuous	4
X	rdxssp	PMStripe12W	Pavement Marking Traffic Stripe 12in White	0	0 / Continuous	4
X	rdxssp	PMStripe12W(2-4)	Pavement Marking 2/4 Skip Traffic Stripe 12in White	0	0 / PM-Stripe-SKIP 2-4	4
X	rdxssp	PMStripe12W(3-9)	Pavement Marking 3/9 Skip Traffic Stripe 12in White	0	0 /PM-Stripe-SKIP 3-9	4
X	rdxssp	PMStripe12Y	Pavement Marking Traffic Stripe 12in Yellow	4	0 / Continuous	4
X	rdxssp	PMStripe16B	Pavement Marking Traffic Stripe 16in Black	3	0 / Continuous	5
X	rdxssp	PMStripe16W	Pavement Marking Traffic Stripe 16in White	0	0 / Continuous	5
X	rdxssp	PMStripe16Y	Pavement Marking Traffic Stripe 16in Yellow	4	0 / Continuous	5
X	rdxssp	PMStripe18B	Pavement Marking Traffic Stripe 18in Black	3	0 / Continuous	6
X	rdxssp	PMStripe18W	Pavement Marking Traffic Stripe 18in White	0	0 / Continuous	6
X	rdxssp	PMStripe18Y	Pavement Marking Traffic Stripe 18in Yellow	4	0 / Continuous	6
X	rdxssp	PMStripe24W	Pavement Marking Traffic Stripe 24in White	0	0 / Continuous	7
X	rdxssp	PMStripe24Y	Pavement Marking Traffic Stripe 24in Yellow	4	0 / Continuous	7
X	rdxssp	PMStripe6B	Pavement Marking Traffic Stripe 6in Black	3	0 / Continuous	2
X	rdxssp	PMStripe6B(10-30)	Pavement Marking 10/30 Skip Traffic Stripe 6in Black	3	0 / PM-Stripe-SKIP 10-30	2
X	rdxssp	PMStripe6Bl	Pavement Marking Traffic Stripe 6in Blue	1	0 / Continuous	2
X	rdxssp	PMStripe6DY	Pavement Marking Traffic Stripe 6in Double Yellow	4	0 / Continuous	2
X	rdxssp	PMStripe6W	Pavement Marking Traffic Stripe 6in White	0	0 / Continuous	2
X	rdxssp	PMStripe6W(10-30)	Pavement Marking 10/30 Skip Traffic Stripe 6in White	0	0 /PM-Stripe-SKIP 10-30	2
X	rdxssp	PMStripe6W(2-4)	Pavement Marking 2/4 Skip Traffic Stripe 6in White	0	0 /PM-Stripe-SKIP 2-4	2
X	rdxssp	PMStripe6W(3-9)	Pavement Marking 3/9 Skip Traffic Stripe 6in White	0	0 /PM-Stripe-SKIP 3-9	2
X	rdxssp	PMStripe6W(6-10)	Pavement Marking 6/10 Skip Traffic Stripe 6in White	0	0 /PM-Stripe-SKIP 6-10	2
X	rdxssp	PMStripe6Y	Pavement Marking Traffic Stripe 6in Yellow	4	0 / Continuous	2
X	rdxssp	PMStripe6Y(10-30)	Pavement Marking 10/30 Skip Traffic Stripe 6in Yellow	4	0 /PM-Stripe-SKIP 10-30	2
X	rdxssp	PMStripe6Y(2-4)	Pavement Marking 2/4 Skip Traffic Stripe 6in Yellow	4	0 /PM-Stripe-SKIP 2-4	2
X	rdxssp	PMStripe6Y(6-10)	Pavement Marking 6/10 Skip Traffic Stripe 6in Yellow	4	0 /PM-Stripe-SKIP 6-10	2
X	rdxssp	PMStripe8B	Pavement Marking Traffic Stripe 8in Black	3	0 / Continuous	3
X	rdxssp	PMStripe8W	Pavement Marking Traffic Stripe 8in White	0	0 / Continuous	3
X	rdxssp	PMStripe8W(3-9)	Pavement Marking 3/9 Skip Traffic Stripe 8in White	0	0 /PM-Stripe-SKIP 3-9	2
X	rdxssp	PMStripe8Y	Pavement Marking Traffic Stripe 8in Yellow	4	0 / Continuous	3
X	rdxssp	PMStripe9C(10-30)	Pavement Marking 10/30 Skip Traffic Stripe 9in Contrast	0	0 /PM-Stripe-SKIP 10-30	2
X	rdxssp	PMStripeRumbleCL	Center Line Rumble Stripes (Use to Quantify Rumble Strips) (NonPlotting)	4	PM-Stripe-RumbleStripeLeft / PM-Stripe-RumbleStripe	2
X	rdxssp	PMStripeRumbleWL	Rumble Stripes (6in White Thermoplastic Over Rumble Strips) (Left)	0	PM-Stripe-RumbleStripeLeft / PM-Stripe-RumbleStripe	2
X	rdxssp	PMStripeRumbleWR	Rumble Stripes (6in White Thermoplastic Over Rumble Strips) (Right)	0	PM-Stripe-RumbleStripeRight / PM-Stripe-RumbleStripe	2
X	rdxssp	PMStripeRumbleYL	Rumble Stripes (6in Yellow Thermoplastic Over Rumble Strips) (Left)	4	PM-Stripe-RumbleStripeLeft / PM-Stripe-RumbleStripe	2
X	rdxssp	PMStripeRumbleYR	Rumble Stripes (6in Yellow Thermoplastic Over Rumble Strips) (Right)	4	PM-Stripe-RumbleStripeRight / PM-Stripe-RumbleStripe	2
X	rdxssp	PMStripeVibeWL	Pavement Marking Auditory and Vibratory 6in White (Left)	0	PM-Stripe-VibratoryLeft /PM-Stripe-Vibratory	2
X	rdxssp	PMStripeVibeWR	Pavement Marking Auditory and Vibratory 6in White (Right)	0	PM-Stripe-VibratoryRight /PM-Stripe-Vibratory	2
X	rdxssp	PMStripeVibeYL	Pavement Marking Auditory and Vibratory 6in Yellow (Left)	4	PM-Stripe-VibratoryLeft /PM-Stripe-Vibratory	2
X	rdxssp	PMStripeVibeYR	Pavement Marking Auditory and Vibratory 6in Yellow (Right)	4	PM-Stripe-VibratoryRight /PM-Stripe-Vibratory	2
	rdxssp	PointLocator_ep	Point Locator Symbol (Existing)	4	0 / Continuous	0

Critical	Rule	Level Name	Level Description	ByLevel Color	ByLevelStyle / Linetype	ByLevel Weight
X	rdxssp	PoleConc	Concrete Strain Pole	0	0 / Continuous	2
X	rdxssp	PoleConc_ep	Concrete Strain Pole (Existing)	0	2 / DGN2	1
X	rdxssp	PoleFound	Pole Foundation	0	0 / Continuous	2
X	rdxssp	PoleLight	Light Pole	2	0 / Continuous	1
X	rdxssp	PoleLight_ep	Light Pole (Existing)	2	2 / DGN2	1
X	rdxssp	PoleLightHM	High Mast Light Pole	3	0 / Continuous	1
X	rdxssp	PoleLightHM_ep	High Mast Light Pole (Existing)	2	2 / DGN2	1
	rdxssp	PoleLightID	Light Pole Location / ID	4	0 / Continuous	1
X	rdxssp	PoleShared	Power Pole Electric (Above Ground) Shared w/ Transformer	3	0 / Continuous	2
X	rdxssp	PoleSteelStrain	Steel Strain Pole	0	0 / Continuous	2
X	rdxssp	PoleSteelStrain_ep	Steel Strain Pole (Existing)	0	2 / DGN2	1
X	rdxssp	PoleWoodStrain	Wood Strain Pole	0	0 / Continuous	2
X	rdxssp	PoleWoodStrain_ep	Wood Strain Pole (Existing)	0	2 / DGN2	1
X	rdxssp	Pond_px	Pond Lines on Cross Sections	2	0 / Continuous	2
X	rdxssp	PropertyLine_ep	Property Lines (Existing)	3	0 / Continuous	0
X	rdxssp	PullBox	Pull Boxes (All Types)	3	0 / Continuous	1
X	rdxssp	PvtAnalysisCrown_px	Pavement Analysis Crowning on Cross Sections - Component Property	7	0 / Continuous	1
X	rdxssp	PvtAnalysisFail_px	Pavement Analysis Failure on Cross Sections - Component Property	3	0 / Continuous	1
X	rdxssp	PvtAnalysisMax_px	Pavement Analysis Acceptable Maximum Range on Cross Sections - Component Property	5	0 / Continuous	1
X	rdxssp	PvtAnalysisMin_px	Pavement Analysis Acceptable Minimum Range on Cross Sections - Component Property	4	0 / Continuous	1
X	rdxssp	PvtAnalysisOptiml_px	Pavement Analysis Optimal on Cross Sections - Component Property	2	0 / Continuous	1
X	rdxssp	Railing_px	Railing Components and Cross Sections Shapes	9	0 / Continuous	2
	rdxssp	ReferencePt_dp	Survey and Construction Reference Point Details and Elements	4	0 / Continuous	2
X	rdxssp	ReflPaintWht	Reflective Paint - Island Nose (White)	0	0 / Continuous	3
X	rdxssp	ReflPaintYel	Reflective Paint - Island Nose (Yellow)	4	0 / Continuous	3
	rdxssp	RegionBdry_dp	Boundary Line for Regions in Corridor Design (For Autodesk Use)	0	0 / Continuous	0
X	rdxssp	RipRap_px	Rip Rap, Rubble on Cross Sections	4	1 / DGN1	2
X	rdxssp	RPM_ep	Reflective Pavement Markers (Existing)	2	2 / DGN2	1
X	rdxssp	RPM1	Raised Pavement Markers, White	0	0 / Continuous	2
X	rdxssp	RPM2	Raised Pavement Markers, White - Red	3	0 / Continuous	2
X	rdxssp	RPM3	Raised Pavement Markers, Yellow	4	0 / Continuous	2
X	rdxssp	RPM4	Raised Pavement Markers, Yellow - Yellow	9	0 / Continuous	2
X	rdxssp	RPM5	Raised Pavement Markers, Yellow - Red	6	0 / Continuous	2
X	rdxssp	RPM6	Raised Pavement Markers, Blue	1	0 / Continuous	2
X	rdxssp	RumbleStrip1	Rumble Strips Continuous Array	0	PM-RumbleSolid	2
X	rdxssp	RumbleStrip2	Rumble Strips Skip Array	0	PM-RumbleSkip	2
X	rdxssp	RWLine	Right of Way Lines	4	RW-Proposed	2
X	rdxssp	RWLine_ep	Right of Way Lines (Existing)	3	RW-Existing	1
X	rdxssp	RWLine_ex	Right of Way Lines on Cross Sections (Existing)	3	RW-Existing	1
X	rdxssp	RWLine_px	Right of Way Lines on Cross Sections	4	RW-Proposed	2
X	rdxssp	SanitaryFM_ex	Force Main Lines on Cross Sections (Existing)	2	2 / DGN2	1
X	rdxssp	SanitaryFM_px	Force Main Lines on Cross Sections	2	0 / Continuous	1
X	rdxssp	SanitarySewer_ex	Sanitary Sewer Lines on Cross Sections (Existing)	2	2 / DGN2	0
X	rdxssp	SanitarySewer_px	Sanitary Sewer Lines on Cross Sections	2	0 / Continuous	1
X	rdxssp	SanitarySewerEff_ex	Sanitary Effluent on Cross Sections (Existing)	5	0 / Continuous	0
X	rdxssp	SanitarySewerEff_px	Sanitary Effluent on Cross Sections	5	0 / Continuous	0
X	rdxssp	SawCuts	Saw Cuts	3	3 / DGN3	0

Critical	Rule	Level Name	Level Description	ByLevel Color	ByLevelStyle / Linetype	ByLevel Weight
	rdxssp	Scale_dp	Bar Scale, Scale Label Elements	0	0 / Continuous	2
	rdxssp	Scratch1_dp	Scratch Level for Temporary or Informational Items	4	0 / Continuous	0
	rdxssp	Scratch2_dp	Scratch Level for Temporary or Informational Items	5	0 / Continuous	0
	rdxssp	ScratchEle_dp	Scratch Level for Draft Elements, Temporary Elements, Etc. (DO NOT PLOT)	3	0 / Continuous	0
	rdxssp	ScratchEle2_dp	Scratch Level for Draft Elements, Temporary Elements, Etc. (DO NOT PLOT)	4	0 / Continuous	0
	rdxssp	SheetBorder_dp	Sheet Border	1	0 / Continuous	4
	rdxssp	SheetLines_dp	Sheet Lines	1	0 / Continuous	2
	rdxssp	SheetLinesMisc1_dp	Sheet Lines	1	0 / Continuous	0
	rdxssp	SheetLinesMisc2_dp	Sheet Lines	2	0 / Continuous	2
	rdxssp	SheetLinesMisc3_dp	Sheet Lines	3	0 / Continuous	2
	rdxssp	SheetLinesMisc4_dp	Sheet Lines	4	0 / Continuous	2
X	rdxssp	ShldrBase_px	Shoulder Base on Cross Sections	3	0 / Continuous	2
X	rdxssp	ShldrMilling_px	Shoulder Milling Component on Cross Sections - Component Property	7	0 / Continuous	2
X	rdxssp	ShldrOverbuild_px	Shoulder Overbuild on Cross Sections - Component Property	4	0 / Continuous	1
X	rdxssp	ShldrOverlay_px	Shoulder Overlay on Cross Sections - Component Property	1	0 / Continuous	1
X	rdxssp	ShldrPaved_px	Shoulder Lines on Cross Sections (Paved)	1	0 / Continuous	2
X	rdxssp	ShldrUnpaved_px	Shoulder Lines on Cross Sections (Unpaved)	2	0 / Continuous	2
X	rdxssp	Sidewalk_ex	Sidewalk Elements on Cross Sections (Existing)	0	2 / DGN2	1
X	rdxssp	Sidewalk_px	Sidewalk Elements on Cross Sections	0	0 / Continuous	2
	rdxssp	SidewalkBack_er	Back of Sidewalk Line Profile (Existing)	2	2 / DGN2	1
	rdxssp	SidewalkBack_pr	Back of Sidewalk Line Profile	5	0 / Continuous	2
X	rdxssp	SidewalkBase_px	Sidewalk Subgrade on Cross Sections	3	0 / Continuous	2
X	rdxssp	SignCantilever	Sign Symbol Cantilever	0	0 / Continuous	1
X	rdxssp	SignCantilever_ep	Sign Symbol Cantilever (Existing)	0	2 / DGN2	0
	rdxssp	SignDetail	Sign Details	0	0 / Continuous	2
	rdxssp	SignLettersAZ	Alphabet Cell Library Letter A-Z Numbers 0-9	0	0 / Continuous	0
	rdxssp	SignMisc	Sign Symbols (Miscellaneous)	3	0 / Continuous	1
	rdxssp	SignMisc_ep	Sign Symbols (Miscellaneous) (Existing)	1	1 / DGN1	1
X	rdxssp	SignPanel	Sign Panels - Regulatory	0	0 / Continuous	2
X	rdxssp	SignPanel_ep	Sign Panel Elements (Existing)	0	2 / DGN2	1
X	rdxssp	SignPanelBorder	Sign Panel Border on Sign Details	0	0 / Continuous	1
X	rdxssp	SignPanelC	Sign Panels - Civil	1	0 / Continuous	2
X	rdxssp	SignPanelDetRed	Sign Panel Details in Red	3	0 / Continuous	2
X	rdxssp	SignPanelG	Sign Panels - Guide	2	0 / Continuous	2
X	rdxssp	SignPanell	Sign Panels - Special Interest	9	0 / Continuous	2
X	rdxssp	SignPanelT	Sign Panels - Construction	6	0 / Continuous	2
X	rdxssp	SignPanelW	Sign Panels - Warning	4	0 / Continuous	2
X	rdxssp	SignSpanwire	Span Wire Signing Assembly	2	0 / Continuous	1
X	rdxssp	SignSpanwire_ep	Span Wire Signing Assembly (Existing)	2	2 / DGN2	1
X	rdxssp	SignSpecial	Special Signs / Guide Signs	2	0 / Continuous	2
X	rdxssp	SignSupport	Ground Mounted Sign Support Symbol (All Types)	1	0 / Continuous	1
X	rdxssp	SignSymbol_px	Sign Structure and Foundation on Cross Sections	4	0 / Continuous	2
X	rdxssp	SignTruss	Sign Symbol Truss	3	0 / Continuous	1
X	rdxssp	SignTruss_ep	Sign Symbol Truss (Existing)	3	2 / DGN2	1
X	rdxssp	Slopes_px	Slope Lines on Cross Sections	9	0 / Continuous	2
X	rdxssp	SoilBoxes_px	Soil Boxes and Borings on Cross Sections	4	0 / Continuous	1
	rdxssp	SpecialDetails_px	Special Details on Cross Sections	6	0 / Continuous	1
	rdxssp	StationTicL_dp	Station Tic Marks (Large) and Text	0	0 / Continuous	2

Critical	Rule	Level Name	Level Description	ByLevel Color	ByLevelStyle / Linetype	ByLevel Weight
	rdxssp	StationTicS_dp	Station Tic Marks (Small) and Text	0	0 / Continuous	2
X	rdxssp	StreetLights_px	Street Lights on Cross Sections	3	0 / Continuous	1
	rdxssp	Structure_px	Signal and Sign Structures on Cross Sections	0	0 / Continuous	2
X	rdxssp	SubDsgn_px	Sub Design on Cross Sections Including Sub-base	4	0 / Continuous	1
X	rdxssp	Subsoil_px	Subsoil Or Undercut on Cross Sections	4	0 / Continuous	2
X	rdxssp	SubsoilFinal_px	Subsoil Final for Multiline on Cross Sections	18	0 / Continuous	1
X	rdxssp	SubsoilProp_px	Subsoil Proposed for Multiline on Cross Sections	8	0 / Continuous	1
	rdxssp	SumBoxBorder_dp	Summary Boxes Borders	4	0 / Continuous	3
	rdxssp	SumBoxLines_dp	Summary Boxes Lines and Miscellaneous Items	4	0 / Continuous	1
	rdxssp	SumBoxLinesMin_dp	Summary Boxes Lines Minor Line and Miscellaneous Items	4	0 / Continuous	0
	rdxssp	Tables_dp	Data Tables and All Autodesk Tables	0	0 / Continuous	1
X	rdxssp	TeleBur_ex	Telephone on Cross Sections (Buried) (Miscellaneous) (Existing)	6	2 / DGN2	1
X	rdxssp	TeleBur_px	Telephone on Cross Sections (Buried) (Miscellaneous)	6	0 / Continuous	1
X	rdxssp	TemplateBottom_px	Bottom of Template for Multiline on Cross Sections	6	0 / Continuous	1
X	rdxssp	TemplateFinal_px	Final Template for Multiline on Cross Sections	2	0 / Continuous	1
X	rdxssp	TemplateTop_px	Top of Template for Multiline on Cross Sections	7	0 / Continuous	1
X	rdxssp	TerrainLine_ex	Ground Line for Multiline on Cross Sections (Existing)	5	0 / Continuous	1
	rdxssp	TextBLStation	Text - B/L Station and Tics	0	0 / Continuous	2
	rdxssp	TextConstEle	Text - Construction Element	0	0 / Continuous	1
	rdxssp	TextCurveData	Text - Curve Data Note	0	0 / Continuous	2
	rdxssp	TextDetails	Text - Detail Notes	4	0 / Continuous	2
	rdxssp	TextDrainInvElev_ep	Text - Drainage Invert Elevation (Existing)	0	0 / Continuous	1
	rdxssp	TextDrainLabel_ep	Text - Drainage (Existing)	0	0 / Continuous	1
	rdxssp	TextElevLabel	Text - Elevation Labels	4	0 / Continuous	0
	rdxssp	TextGeotech	Text - Soil Borings and Labels	0	0 / Continuous	2
	rdxssp	TextLabel	Text - Label	0	0 / Continuous	2
	rdxssp	TextLandscape	Text - Landscape Labels	0	0 / Continuous	1
	rdxssp	TextMajor	Text - Major	0	0 / Continuous	5
	rdxssp	TextMinor	Text - Minor	0	0 / Continuous	0
	rdxssp	TextMisc	Text - Miscellaneous	0	0 / Continuous	1
	rdxssp	TextNotes	Text - Notes	4	0 / Continuous	1
	rdxssp	TextProfLabel	Text - Profile, Horizontal and Vertical Axis Labels	0	0 / Continuous	2
	rdxssp	TextProjLabel	Text - Begin and End Project Label with Leader Lines	1	0 / Continuous	2
	rdxssp	TextPtLabel	Text - Point Labels	4	0 / Continuous	0
	rdxssp	TextShtNo	Text - Sheet Number	0	0 / Continuous	2
	rdxssp	TextSubUtilLabel_ep	Text - Subsurface Utilities (Existing)	0	0 / Continuous	1
	rdxssp	TextSurveyLabel	Text - Survey Labels	0	0 / Continuous	0
	rdxssp	TextTables	Text - Key Sheet Indexes and Table Data	4	0 / Continuous	2
	rdxssp	TextTitle	Text - Title	0	0 / Continuous	3
	rdxssp	TextTopoLabel_ep	Text - Topography (Existing)	0	0 / Continuous	1
	rdxssp	TextUtilLabel_ep	Text - Utilities (Existing)	0	0 / Continuous	1
	rdxssp	TextXSBL_dp	Text - Cross Section Baseline Labels	0	0 / Continuous	2
	rdxssp	TextXSDrain_ex	Text - Cross Section Drainage Labels (Existing)	10	0 / Continuous	2
	rdxssp	TextXSDrain_px	Text - Cross Section Drainage Labels	10	0 / Continuous	2
	rdxssp	TextXSElev	Text - Cross Section Elevations	2	0 / Continuous	1
	rdxssp	TextXSElev_ex	Text - Cross Section Elevations (Existing)	2	0 / Continuous	1
	rdxssp	TextXSElev_px	Text - Cross Section Elevations	0	0 / Continuous	1
	rdxssp	TextXSGPKPts_dp	Text - Cross Section Points Labels	4	0 / Continuous	0



Critical	Rule	Level Name	Level Description	ByLevel Color	ByLevelStyle / Linetype	ByLevel Weight
	rdxssp	TextXSNotes_dp	Text - Cross Section Notes	0	0 / Continuous	2
	rdxssp	TextXSSlope_dp	Text - Cross Section Slope Labels (rise:run format)	0	0 / Continuous	2
	rdxssp	TextXSSlopePvt_dp	Text - Cross Section Pavement Slope Labels	0	0 / Continuous	2
X	rdxssp	TrafSeparator_ex	Traffic Separator on Cross Sections (All Types) (Existing)	6	2 / DGN2	1
X	rdxssp	TrafSeparator_px	Traffic Separator on Cross Sections (All Types)	6	0 / Continuous	2
X	rdxssp	TrafSeparatorBase_px	Traffic Separator SubgradeSubgrade on Cross Sections	3	0 / Continuous	2
	rdxssp	TypicalMisc	Typical Items (Miscellaneous)	0	0 / Continuous	2
	rdxssp	UtilsMisc_ex	Utility Items on Cross Sections (Miscellaneous) (Existing)	8	2 / DGN2	1
	rdxssp	UtilsMisc_px	Utility Items on Cross Sections (Miscellaneous)	8	0 / Continuous	1
	rdxssp	Vehicle	Vehicle for Calculating Turning Radius	7	0 / Continuous	2
	rdxssp	Viewport	Viewport (For AutoCAD Use)	3	0 / Continuous	0
	rdxssp	VoidArea_dx	Void Area on Cross Sections	1	0 / Continuous	0
X	rdxssp	WallBarrier_ex	Barrier Wall on Cross Section (Existing)	6	3 / DGN3	1
X	rdxssp	WallBarrier_px	Barrier Wall on Cross Section	6	0 / Continuous	2
X	rdxssp	WallFooter_px	Wall Footer (Concrete) on Cross Sections - Component Symbolology/Material on All Wall Footers/Leveling Pads	2	0 / Continuous	1
X	rdxssp	WallGravBase_px	Gravity Wall Subgrade on Cross Sections	3	0 / Continuous	2
X	rdxssp	WallGravity_px	Gravity Wall on Cross Sections	11	0 / Continuous	2
X	rdxssp	WallMedianBase_px	Median Wall Subgrade on Cross Sections	3	0 / Continuous	2
X	rdxssp	WallRetain_px	Retaining Walls on Cross Sections	6	0 / Continuous	1
X	rdxssp	WallShldrBase_px	Shoulder Wall Subgrade on Cross Sections	3	0 / Continuous	2
X	rdxssp	Water_ex	Water on Cross Sections (Existing)	1	2 / DGN2	1
X	rdxssp	Water_px	Water on Cross Sections	1	0 / Continuous	1
X	rdxssp	WaterNP_ex	Raw Water Pipes on Cross Sections (Existing)	5	0 / Continuous	1
X	rdxssp	WaterNP_px	Raw Water Pipes on Cross Sections	5	0 / Continuous	1
	rdxssp	Wetland_ep	Wetland Boundary on Cross Sections (Existing)	2	RD-Wetland-Existing	1
	rdxssp	WetlandEdge_ep	Edge of Mangrove, Wetlands (Marsh or Swamp) (Existing)	2	RD-Wetland-Existing	0
	rdxssp	Xreference01_dp	Reference Files (For AutoCAD Use)	0	0 / Continuous	1
	rdxssp	Xreference02_dp	Reference Files (For AutoCAD Use)	0	0 / Continuous	1
	rdxssp	Xreference03_dp	Reference Files (For AutoCAD Use)	0	0 / Continuous	1
	rdxssp	Xreference04_dp	Reference Files (For AutoCAD Use)	0	0 / Continuous	1
X	rdxssp	XSBaseTop_px	Cross Section Top of Base	3	0 / Continuous	2
	rdxssp	XSCell	GEOPAK Cross Section Cell/Block and Profile Cell/Block	8	0 / Continuous	1
X	rdxssp	XSExtendGrdLine_ex	Cross Section Extend Ground Lines (Existing)	21	2 / DGN2	1
X	rdxssp	XSGrdLine_ex	Cross Section Ground Lines (Existing)	2	2 / DGN2	1
X	rdxssp	XSGrdLine_px	Cross Section Roadway Ground Lines	1	0 / Continuous	2
	rdxssp	XSMisc_ex	Cross Section Roadway Items (Miscellaneous) (Existing)	4	3 / DGN3	1
	rdxssp	XSMisc_px	Cross Section Items (Miscellaneous)	0	0 / Continuous	2
	rdxssp	XSPt_ep	Cross Section Point, Station (Existing)	2	1 / DGN1	0
	rdxssp	XSShapeDep01_dp	Cross Section Shape Dependent	11	0 / Continuous	2
	rdxssp	XSShapeDep02_dp	Cross Section Shape Dependent	12	0 / Continuous	2
	rdxssp	XSShapeDep03_dp	Cross Section Shape Dependent	13	0 / Continuous	2
	rdxssp	XSShapeDep04_dp	Cross Section Shape Dependent	14	0 / Continuous	2
	rdxssp	XSShapeDep05_dp	Cross Section Shape Dependent	15	0 / Continuous	2
	rdxssp	XSShapeDep06_dp	Cross Section Shape Dependent	16	0 / Continuous	2
	rdxssp	XSShapeDep07_dp	Cross Section Shape Dependent	17	0 / Continuous	2
	rdxssp	XSShapeDep08_dp	Cross Section Shape Dependent	18	0 / Continuous	2
	rdxssp	XSShapeDep09_dp	Cross Section Shape Dependent	19	0 / Continuous	2

Critical	Rule	Level Name	Level Description	ByLevel Color	ByLevelStyle / Linetype	Bylevel Weight
	rdxssp	XSShapeDep10_dp	Cross Section Shape Dependent	20	0 / Continuous	2
	rdxssp	XSShapeIndep01_dp	Cross Section Shape Independent	1	0 / Continuous	2
	rdxssp	XSShapeIndep02_dp	Cross Section Shape Independent	2	0 / Continuous	2
	rdxssp	XSShapeIndep03_dp	Cross Section Shape Independent	3	0 / Continuous	2
	rdxssp	XSShapeIndep04_dp	Cross Section Shape Independent	4	0 / Continuous	2
	rdxssp	XSShapeIndep05_dp	Cross Section Shape Independent	5	0 / Continuous	2
	rdxssp	XSShapeIndep06_dp	Cross Section Shape Independent	6	0 / Continuous	2
	rdxssp	XSShapeIndep07_dp	Cross Section Shape Independent	7	0 / Continuous	2
	rdxssp	XSShapeIndep08_dp	Cross Section Shape Independent	8	0 / Continuous	2
	rdxssp	XSShapeIndep09_dp	Cross Section Shape Independent	9	0 / Continuous	2
	rdxssp	XSShapeIndep10_dp	Cross Section Shape Independent	10	0 / Continuous	2
X	rdxssp	XSTypical_px	Cross Section Roadway Pavement Typical	1	0 / Continuous	2

## RWDTRD - Right of Way Detail for Roadway

Critical	Rule	Level Name	Level Description	ByLevel Color	ByLevelStyle / Linetype	Bylevel Weight
	rwdtrd	ActivePointCell_dp	Active Point Cell	4	0 / Continuous	10
	rwdtrd	AdhocPoint_dp	Adhoc Points Placed by SheetInfo	0	4 / DGN4	0
	rwdtrd	BaselineSurvey	Baseline Survey	0	0 / Continuous	2
	rwdtrd	CLConst_dp	Center Line of Construction	0	0 / Continuous	2
	rwdtrd	COGO_dp	COGO Information	3	0 / Continuous	1
	rwdtrd	ConstLines	Construction Lines and References	1	0 / Continuous	0
	rwdtrd	ConstLines_pm	Construction Lines	4	0 / Continuous	0
	rwdtrd	CurveData_dp	Curve and Coordinate Data Elements Including PC, PT, PI Symbols	4	0 / Continuous	2
	rwdtrd	CurveDataLabel_dp	Curve Data Labels PC,PI, PT	0	0 / Continuous	2
	rwdtrd	DimLines_dp	Dimension Lines, Corresponding Terminators, Equation Lines	0	0 / Continuous	1
X	rwdtrd	EaseLicLine	Easement License Agreement Line	5	6 / DGN6	0
X	rwdtrd	EaseLine_ep	Easement Lines (Existing)	1	RW-Easement	1
X	rwdtrd	EasePerpLine	Easement Lines Perpetual (Proposed)	4	RW-PerpetualEasement	1
X	rwdtrd	EaseTempLine	Easement Lines Temporary (Proposed)	6	RW-TemporaryEasement	0
X	rwdtrd	EaseTempLine_ep	Easement Lines Temporary (Existing)	6	RW-TemporaryEasement	1
	rwdtrd	GovCityLimitLine_ep	Government:City Limit Line (Existing)	3	RW-CityLimit-Type 1	0
	rwdtrd	GovCountyLine_ep	Government:County Line (Existing)	3	RW-CountyLine	3
	rwdtrd	GovQuarterLine_ep	Government:Quarter Section Line (Existing)	3	RW-QuaterSection	1
	rwdtrd	GovSectionLine_ep	Section Lines (Existing)	10	RW-SectionLine	2
	rwdtrd	GovStateLine_ep	Government:State Line (Existing)	2	RW-StateLine	3
X	rwdtrd	GovTwpRgeLine_ep	Township / Range Lines (Existing)	10	RW-TownshipRange	2
	rwdtrd	ImageAttachment_dp	Image Attachments	0	0 / Continuous	0
X	rwdtrd	LARWLine	Limited Access Right of Way Lines	4	RW-LimitedAccess-Proposed	2
X	rwdtrd	LARWLine_ep	Limited Access Right of Way Lines (Existing)	4	RW-LimitedAccess-Existing	1
	rwdtrd	LeaderLine_dp	Leader Line and Terminator with Text	0	0 / Continuous	1
	rwdtrd	Miscellaneous0	Undefined Proposed Item - Color Blue Weight 0	1	0 / Continuous	0
	rwdtrd	Miscellaneous1	Undefined Proposed Item - Color Blue Weight 1	1	0 / Continuous	1
	rwdtrd	Miscellaneous2	Undefined Proposed Item - Color Blue Weight 2	1	0 / Continuous	2
	rwdtrd	Miscellaneous3	Undefined Proposed Item - Color Green Weight 0	2	0 / Continuous	0
	rwdtrd	Miscellaneous4	Undefined Proposed Item - Color Green Weight 1	2	0 / Continuous	1

Critical	Rule	Level Name	Level Description	ByLevel Color	ByLevelStyle / Linetype	ByLevel Weight
	rwtdrd	Miscellaneous5	Undefined Proposed Item - Color Green Weight 2	2	0 / Continuous	2
	rwtdrd	Miscellaneous6	Undefined Proposed Item - Color Red Weight 0	3	0 / Continuous	0
	rwtdrd	Miscellaneous7	Undefined Proposed Item - Color Red Weight 1	3	0 / Continuous	1
	rwtdrd	Miscellaneous8	Undefined Proposed Item - Color Red Weight 2	3	0 / Continuous	2
	rwtdrd	Miscellaneous9	Undefined Proposed Item - Color Red Weight 3	3	0 / Continuous	3
	rwtdrd	NonPlottingEle_dp	Non-Plotting Items - Construction Elements, Type 66 Elements, Etc.	4	0 / Continuous	0
	rwtdrd	NorthArw_dp	North Arrows	0	0 / Continuous	2
	rwtdrd	PayItem_dp	Pay Item Number Label Elements	4	0 / Continuous	2
	rwtdrd	PointLocator_ep	Point Locator Symbol (Existing)	4	0 / Continuous	0
X	rwtdrd	PropertyLine_ep	Property Lines (Existing)	3	0 / Continuous	0
	rwtdrd	ReferencePt_dp	Survey and Construction Reference Point Details and Elements	4	0 / Continuous	2
X	rwtdrd	RefPtAngleTie	Annotation:Angle Tie:Survey Reference Point / Detail	0	RW-Dimension-Type 1 / Continuous	1
X	rwtdrd	RefPtLeader	Annotation:Leader:Survey Reference Point / Detail	0	RW-Leader / Continuous	1
X	rwtdrd	RefPtLine	Survey Reference Point Line / Detail (Miscellaneous)	0	0 / Continuous	1
X	rwtdrd	RefPtStaTie	Annotation:Station Tie:Survey Reference Point / Detail	0	RW-ArrowTie / Continuous	0
X	rwtdrd	RefPtText	Annotation: Text: Survey Data Reference Point (Miscellaneous)	0	0 / Continuous	1
X	rwtdrd	RRBaseline	Baseline:Rail Road Centerline	4	0 / Continuous	2
X	rwtdrd	RWLine	Right of Way Lines	4	RW-Proposed	2
X	rwtdrd	RWLine_ep	Right of Way Lines (Existing)	3	RW-Existing	1
	rwtdrd	Scratch1_dp	Scratch Level for Temporary or Informational Items	4	0 / Continuous	0
	rwtdrd	Scratch2_dp	Scratch Level for Temporary or Informational Items	5	0 / Continuous	0
	rwtdrd	ScratchEle_dp	Scratch Level for Draft Elements, Temporary Elements, Etc. (DO NOT PLOT)	3	0 / Continuous	0
	rwtdrd	ScratchEle2_dp	Scratch Level for Draft Elements, Temporary Elements, Etc. (DO NOT PLOT)	4	0 / Continuous	0
	rwtdrd	StationTicL_dp	Station Tic Marks (Large) and Text	0	0 / Continuous	2
	rwtdrd	StationTicS_dp	Station Tic Marks (Small) and Text	0	0 / Continuous	2
X	rwtdrd	SubDivLine	Subdivision Line	5	0 / Continuous	0
	rwtdrd	Tables_dp	Data Tables and All Autodesk Tables	0	0 / Continuous	1
	rwtdrd	TextBLStation	Text - B/L Station and Tics	0	0 / Continuous	2
	rwtdrd	TextConstEle	Text - Construction Element	0	0 / Continuous	1
	rwtdrd	TextCurveData	Text - Curve Data Note	0	0 / Continuous	2
	rwtdrd	TextDetails	Text - Detail Notes	4	0 / Continuous	2
	rwtdrd	TextDrainInvElev_ep	Text - Drainage Invert Elevation (Existing)	0	0 / Continuous	1
	rwtdrd	TextDrainLabel_ep	Text - Drainage (Existing)	0	0 / Continuous	1
	rwtdrd	TextElevLabel	Text - Elevation Labels	4	0 / Continuous	0
	rwtdrd	TextLabel	Text - Label	0	0 / Continuous	2
	rwtdrd	TextLandscape	Text - Landscape Labels	0	0 / Continuous	1
	rwtdrd	TextMajor	Text - Major	0	0 / Continuous	5
	rwtdrd	TextMinor	Text - Minor	0	0 / Continuous	0
	rwtdrd	TextMisc	Text - Miscellaneous	0	0 / Continuous	1
	rwtdrd	TextNotes	Text - Notes	4	0 / Continuous	1
	rwtdrd	TextProfLabel	Text - Profile, Horizontal and Vertical Axis Labels	0	0 / Continuous	2
	rwtdrd	TextProjLabel	Text - Begin and End Project Label with Leader Lines	1	0 / Continuous	2
	rwtdrd	TextPtLabel	Text - Point Labels	4	0 / Continuous	0
	rwtdrd	TextShtNo	Text - Sheet Number	0	0 / Continuous	2
	rwtdrd	TextSubUtilLabel_ep	Text - Subsurface Utilities (Existing)	0	0 / Continuous	1
	rwtdrd	TextSurveyLabel	Text - Survey Labels	0	0 / Continuous	0
	rwtdrd	TextTables	Text - Key Sheet Indexes and Table Data	4	0 / Continuous	2
	rwtdrd	TextTitle	Text - Title	0	0 / Continuous	3



Critical	Rule	Level Name	Level Description	ByLevel Color	ByLevelStyle / Linetype	ByLevel Weight
	rwtdrd	TextTopoLabel_ep	Text - Topography (Existing)	0	0 / Continuous	1
	rwtdrd	TextUtilLabel_ep	Text - Utilities (Existing)	0	0 / Continuous	1
	rwtdrd	TextXSElev	Text - Cross Section Elevations	2	0 / Continuous	1
	rwtdrd	Viewport	Viewport (For AutoCAD Use)	3	0 / Continuous	0
	rwtdrd	Xreference01_dp	Reference Files (For AutoCAD Use)	0	0 / Continuous	1
	rwtdrd	Xreference02_dp	Reference Files (For AutoCAD Use)	0	0 / Continuous	1
	rwtdrd	Xreference03_dp	Reference Files (For AutoCAD Use)	0	0 / Continuous	1
	rwtdrd	Xreference04_dp	Reference Files (For AutoCAD Use)	0	0 / Continuous	1
	rwtdrd	XSCell	GEOPAK Cross Section Cell/Block and Profile Cell/Block	8	0 / Continuous	1

## RWENG10 - Right of Way

Critical	Rule	Level Name	Level Description	ByLevel Color	ByLevelStyle / Linetype	ByLevel Weight
	rweng10	ActivePointCell_dp	Active Point Cell	4	0 / Continuous	10
	rweng10	AdhocPoint_dp	Adhoc Points Placed by SheetInfo	0	4 / DGN4	0
101	rweng10	BaselineCurveData	Cell:Baseline Curve Data	0	0 / Continuous	2
X	rweng10	BaselineFlagLT	Annotation:Begin End Baseline Flag Left	0	RW-LeaderLeft / Continuous	2
X	rweng10	BaselineFlagRT	Annotation:Begin End Baseline Flag Right	0	RW-LeaderRight / Continuous	2
X	rweng10	BaselineLeaderWt0	Annotation:Leader:Baseline Survey (weight = 0)	0	RW-Leader / Continuous	0
X	rweng10	BaselineLeaderWt1	Annotation:Leader:Baseline Survey (weight = 1)	0	RW-Leader / Continuous	1
X	rweng10	BaselineLeaderWt2	Annotation:Leader:Baseline Survey (weight = 2)	0	RW-Leader / Continuous	2
X	rweng10	BaselineSideStreet	Baseline:Baseline Side Street	0	0 / Continuous	0
X	rweng10	BaselineStaTie	Annotation:Station Tie:Baseline Station Tie	0	RW-ArrowTie / Continuous	0
	rweng10	BaselineSurvey	Baseline Survey	0	0 / Continuous	2
X	rweng10	BaselineTangentLine	Miscellaneous:Baseline Curve Tangent (PC-PI-PT)	0	2 / DGN2	0
101	rweng10	BaselineTextWt0	Annotation:Text:Baseline Text (weight = 0)	0	0 / Continuous	0
101	rweng10	BaselineTextWt1	Annotation:Text:Baseline Text (weight = 1)	0	0 / Continuous	1
101	rweng10	BaselineTextWt2	Annotation:Text:Baseline Text (weight = 2)	0	0 / Continuous	2
X	rweng10	Building_ep	Buildings (Existing)	1	0 / Continuous	0
X	rweng10	BuildingLeader	Annotation:Leader:Building	0	RW-Leader / Continuous	0
X	rweng10	BuildingStaTie	Annotation:Station Tie:Building	0	RW-ArrowTie / Continuous	0
101	rweng10	BuildingText	Annotation:Text:Buildings	0	0 / Continuous	0
X	rweng10	CLConst_dp	Center Line of Construction	0	0 / Continuous	2
X	rweng10	ClipBorder	Cell:Miscellaneous:R/W Clip Border	4	2 / DGN2	0
X	rweng10	ClipBorderLine	Cell:Miscellaneous:R/W Clip Border	4	0 / Continuous	4
X	rweng10	ClipBorderOutside	Cell:Miscellaneous:R/W Clip Border	3	0 / Continuous	0
X	rweng10	Closing-SameLine	Miscellaneous:Closing Line, Same Point, or Same Line	0	RW-ArrowTie / Continuous	0
101	rweng10	Closing-SameLineText	Miscellaneous:Text:Closing Line, Same Point, or Same Line	0	0 / Continuous	0
	rweng10	COGO_dp	COGO Information	3	0 / Continuous	1
X	rweng10	ConstLimits	Proposed:Limits of Construction Line	3	RW-LimitsofConst	0
X	rweng10	ConstLimitsLeader	Annotation:Leader:Limits of Construction (Proposed)	3	RW-Leader / Continuous	0
X	rweng10	ConstLimitsStaTie	Annotation:Station Tie:Limits of Construction (Proposed)	3	RW-ArrowTie / Continuous	0
101	rweng10	ConstLimitsText	Annotation:Text: Limits of Construction (Proposed)	3	0 / Continuous	0
	rweng10	ConstLines	Construction Lines and References	1	0 / Continuous	0

Critical	Rule	Level Name	Level Description	ByLevel Color	ByLevelStyle / Linetype	ByLevel Weight
	rweng10	ConstLines_pm	Construction Lines	4	0 / Continuous	0
101	rweng10	CoordPtText	Annotation:Text:Miscellaneous:Coordinate Geometry Points	4	0 / Continuous	0
101	rweng10	DataBoxWt0	Cell:Miscellaneous:Data Table Wt0 For Text and Linear Elements	0	0 / Continuous	0
101	rweng10	DataBoxWt1	Cell:Miscellaneous:Data Table Wt1 For Text and Linear Elements	0	0 / Continuous	1
101	rweng10	DataBoxWt2	Cell:Miscellaneous:Data Table Wt2 For Text and Linear Elements	0	0 / Continuous	2
101	rweng10	DataBoxWt3	Cell:Miscellaneous:Data Table Wt3 For Text and Linear Elements	0	0 / Continuous	3
101	rweng10	DataBoxWt4	Cell:Miscellaneous:Data Table Wt4 For Text and Linear Elements	0	0 / Continuous	4
X	rweng10	DetailBorder	Miscellaneous: Border for Mapping Detail	0	3 / DGN3	3
X	rweng10	EaseLicLeader	Annotation:Leader:License (Proposed)	0	RW-Leader / Continuous	1
X	rweng10	EaseLicLine	Easement:License (Proposed)	0	RW-License	1
X	rweng10	EaseLicStaTie	Annotation:Station Tie:License (Proposed)	0	RW-ArrowTie / Continuous	1
101	rweng10	EaseLicText	Annotation:Text:Easement Lines, License (Proposed)	0	0 / Continuous	1
X	rweng10	EaseLicWidthArrow	Annotation:Arrow:License Width (Proposed)	0	RW-Dimension-Type2 / Continuous	1
X	rweng10	EaseLine_ep	Easement:Easement Line (Existing)	1	2 / DGN2	0
X	rweng10	EaseLineCenterline_ep	Baseline:Centerline:Easement (Existing)	1	RW-EasementCL-Existing	0
X	rweng10	EaseLineLeader_ep	Annotation:Leader:Easement (Existing)	1	RW-Leader / Continuous	0
X	rweng10	EaseLineStaTie_ep	Annotation:Station Tie:Easement (Existing)	1	RW-ArrowTie / Continuous	0
101	rweng10	EaseLineText_ep	Annotation:Text:Easement Lines (Existing)	1	0 / Continuous	0
X	rweng10	EaseLineWidthArrow_ep	Annotation:Arrow:Easement Width (Existing)	1	RW-Dimension-Type2 / Continuous	0
X	rweng10	EasePerpLeader	Annotation:Leader:Easement Perpetual (Proposed)	4	RW-Leader / Continuous	1
X	rweng10	EasePerpLine	Easement:Perpetual Easement Line (Proposed)	4	RW-PerpetualEasement	2
X	rweng10	EasePerpStaTie	Annotation:Station Tie:Easement Perpetual (Proposed)	4	RW-ArrowTie / Continuous	1
101	rweng10	EasePerpText	Annotation:Text:Easement Lines, Perpetual (Proposed)	4	0 / Continuous	1
X	rweng10	EasePerpWidthArrow	Annotation:Arrow:Easement Perpetual Width (Proposed)	4	RW-Dimension-Type2 / Continuous	1
X	rweng10	EaseTempLeader	Annotation:Leader:Easement Temporary (Proposed)	6	RW-Leader / Continuous	1
X	rweng10	EaseTempLine	Easement:Temporary Easement Line (Proposed)	6	RW-TemporaryEasement	1
X	rweng10	EaseTempStaTie	Annotation:Station Tie:Easement Temporary (Proposed)	6	RW-ArrowTie / Continuous	1
101	rweng10	EaseTempText	Annotation:Text:Easement Lines, Temporary (Proposed)	6	0 / Continuous	1
X	rweng10	EaseTempWidthArrow	Annotation:Arrow:Easement Temporary Width (Proposed)	6	RW-Dimension-Type2 / Continuous	1
X	rweng10	Fence_ep	Fence (All) (Existing)	6	RD-Fence	0
X	rweng10	FLMap1	Florida Map Items - Weight of 1	1	0 / Continuous	1
X	rweng10	FLMap2	Florida Map Items - Weight of 2	3	0 / Continuous	2
X	rweng10	FLMap3	Florida Map Items - Weight of 3	2	0 / Continuous	3
X	rweng10	FLMap4	Florida Map Items - Color 11 (Interstate)	11	0 / Continuous	3
X	rweng10	FLMap5	Florida Map Items - Style 7, Weight. 5 (State Line)	3	7 / DGN7	5
X	rweng10	GenNotesLeader	Annotation:Leader:Miscellaneous:General Notes	0	RW-Leader / Continuous	2
101	rweng10	GenNotesText	Annotation:Miscellaneous:Text: General Notes	0	0 / Continuous	2
X	rweng10	GovCityLimitHLine_ep	Government:City Limit Line (Hash Only)	3	RW-CityLimit-Type2	0
X	rweng10	GovCityLimitLine_ep	Government:City Limit Line	3	RW-CityLimit-Type1	0
X	rweng10	GovCountyLine_ep	Government:County Line	3	RW-CountyLine	3
X	rweng10	GovGrantLine_ep	Government:Grant Line	3	RW-GrantLine	2
X	rweng10	GovGreenLeaderWt0_ep	Annotation:Leader:Government (color = green)(weight = 0)	2	RW-Leader / Continuous	0
X	rweng10	GovGreenLeaderWt2_ep	Annotation:Leader:Government (color = green)(weight = 2)	2	RW-Leader / Continuous	2
X	rweng10	GovGreenStaTie_ep	Annotation:Station Tie:Government (color = green)	2	RW-ArrowTie / Continuous	0
101	rweng10	GovGreenTextWt0_ep	Annotation:Government Text Green Weight of 0	2	0 / Continuous	0
101	rweng10	GovGreenTextWt2_ep	Annotation:Government Text Green Weight of 2	2	0 / Continuous	2

Critical	Rule	Level Name	Level Description	ByLevel Color	ByLevelStyle / Linetype	ByLevel Weight
X	rweng10	GovLotLine_ep	Government:Lot Line	3	0 / Continuous	0
X	rweng10	GovMeanderLine_ep	Government:Meander Line	3	3 / DGN3	1
X	rweng10	GovParkHLine_ep	Government:National or State Park or Forest Line (Hash Only)	2	RW-Nat/StPark/Forest-Type2	0
X	rweng10	GovParkLine_ep	Government:National or State Park or Forest Line	2	RW-Nat/StPark/Forest-Type1	0
X	rweng10	GovQtrQtrLine_ep	Government:Quarter / Quarter Section Line	3	RW-QuarterSection	0
X	rweng10	GovQuarterLine_ep	Government:Quarter Section Line	3	RW-QuarterSection	1
X	rweng10	GovRedLeaderWt0_ep	Annotation:Leader:Government (color = red)(weight = 0)	3	RW-Leader / Continuous	0
X	rweng10	GovRedLeaderWt2_ep	Annotation:Leader:Government (color = red)(weight = 2)	3	RW-Leader / Continuous	2
X	rweng10	GovRedStaTie_ep	Annotation:Station Tie:Government (color = red)	3	RW-ArrowTie / Continuous	0
101	rweng10	GovRedTextWt0_ep	Annotation:Government Text Red Weight of 0	3	0 / Continuous	0
101	rweng10	GovRedTextWt2_ep	Annotation:Government Text Red Weight of 2	3	0 / Continuous	2
X	rweng10	GovSectionLine_ep	Government:Section Line	3	RW-SectionLine	2
X	rweng10	GovStateLine_ep	Government:State Line	2	RW-StateLine	3
X	rweng10	GovTwpRgeLine_ep	Government:Township and Range Government Survey Line	2	RW-TownshipRange	3
	rweng10	ImageAttachment_dp	Image Attachments	0	0 / Continuous	0
X	rweng10	LARWLine	Proposed:Limited Access Right of Way Line	4	RW-LimitedAccess-Proposed	3
X	rweng10	LARWLine_ep	Existing:Limited Access Right of Way Line	7	RW-LimitedAccess-Existing	0
X	rweng10	Logo_dp	Consultant Engineer of Record Logo	0	0 / Continuous	1
X	rweng10	MaintLeader	Annotation:Leader:Maintenance	4	RW-Leader / Continuous	2
X	rweng10	MaintLine	Proposed:Maintenance Line	4	0 / Continuous	4
X	rweng10	MaintStaTie	Annotation:Station Tie:Maintenance	4	RW-ArrowTie / Continuous	2
101	rweng10	MaintText	Annotation:Text: Maintenance	4	0 / Continuous	2
X	rweng10	MaintWidthArrow	Annotation:Arrow:Maintenance Width (Proposed)	4	RW-Dimension-Type2 / Continuous	2
X	rweng10	MapOutline_dp	Outline for Key Maps	0	0 / Continuous	5
	rweng10	MatchLineMask_dp	Mask Area for Match Line Overlap Areas (For AutoCAD Use)	0	0 / Continuous	0
X	rweng10	MHWL_TIITF_Leader	Annotation:Leader:TIITF:Mean High Water Lines or Ordinary High Water Lines	7	RW-Leader / Continuous	2
X	rweng10	MHWL_TIITF_Line	TIITF:Mean High Water Lines or Ordinary High Water Lines	7	0 / Continuous	3
X	rweng10	MHWL_TIITF_StaTie	Annotation:Station Tie:TIITF:Safe Upland Elevation Lines or Jurisdictional Lines	7	RW-ArrowTie / Continuous	2
101	rweng10	MHWL_TIITF_Text	Annotation:Text:TIITF:Mean High Water Lines or Ordinary High Water Lines	7	0 / Continuous	2
X	rweng10	MHWL_TIITF_WidthArrow	Annotation:Arrow:TIITF:Mean High Water Lines or Ordinary High Water Lines	7	RW-Dimension-Type2 / Continuous	2
X	rweng10	MonConcOpen	Cell:Monument, Concrete Open	4	0 / Continuous	1
X	rweng10	MonConcSolid	Cell:Monument, Concrete Solid	4	0 / Continuous	1
X	rweng10	MonConRW	Cell:Monument, Concrete RW	4	0 / Continuous	2
X	rweng10	MonLeader	Annotation:Leader:Found / Set Monuments (Not Government Corners)	4	RW-Leader / Continuous	0
X	rweng10	MonPermRW	Cell:Monument, RW Permanent (RW Survey Map)	4	0 / Continuous	2
X	rweng10	MonRodOpen	Cell:Monument, Rod Open	4	0 / Continuous	1
X	rweng10	MonRodSolid	Cell:Monument, Rod Solid	4	0 / Continuous	1
X	rweng10	MonStaTie	Annotation:Station Tie:Found / Set Monuments (Not Government Corners)	4	RW-ArrowTie / Continuous	0
101	rweng10	MonText	Annotation:Text:Found / Set Monuments (Not Government Corners)	4	0 / Continuous	0
X	rweng10	Monument_ep	Monuments (All), Stamped Disk or Plate, Photo Control Point, Aerial Targets (Existing)	4	0 / Continuous	0
X	rweng10	Murphy_TIITF_Leader	Annotation:Leader:TIITF:Murphy Reservations Lines	2	RW-Leader / Continuous	1
X	rweng10	Murphy_TIITF_Line	TIITF: Upland TIITF:Murphy Reservations Lines	2	RW-TIITFMurphyResLine	1
X	rweng10	Murphy_TIITF_StaTie	Annotation:Station Tie:TIITF:Murphy Reservations Lines	2	RW-ArrowTie / Continuous	1
101	rweng10	Murphy_TIITF_Text	Annotation:Text:TIITF:Murphy Reservations Lines	2	0 / Continuous	1
X	rweng10	Murphy_TIITF_WidthArrow	Annotation:Arrow:TIITF:Murphy Reservations Lines	2	RW-Dimension-Type2 / Continuous	1
	rweng10	NonPlottingEle_dp	Non-Plotting Items - Construction Elements, Type 66 Elements, Etc.	4	0 / Continuous	0

Critical	Rule	Level Name	Level Description	ByLevel Color	ByLevelStyle / Linetype	ByLevel Weight
X	rweng10	NonVehcLeader_ep	Annotation:Leader:Non- Vehicular Access	3	RW-Leader / Continuous	0
X	rweng10	NonVehcLine_ep	Existing:Non-Vehicular Access Line	3	RW-NonVehicularAccess	0
X	rweng10	NonVehcStaTie_ep	Annotation:Station Tie:Non -Vehicular Access	3	RW-ArrowTie / Continuous	0
101	rweng10	NonVehcText_ep	Annotation:Text:Non-Vehicular Access (Existing)	3	0 / Continuous	0
	rweng10	NorthArw_dp	North Arrows	0	0 / Continuous	2
101	rweng10	ParcelBubble100	Cell:Miscellaneous:Right of Way Parcel Bubble with Leader	3	0 / Continuous	2
101	rweng10	ParcelBubble700	Cell:Miscellaneous:Temporary Easement Parcel Bubble with Leader	6	0 / Continuous	2
101	rweng10	ParcelBubble800	Cell:Miscellaneous:Perpetual Easement Parcel Bubble with Leader	4	0 / Continuous	2
101	rweng10	ParcelBubble900	Cell:Miscellaneous:License Parcel Bubble with Leader	0	0 / Continuous	2
X	rweng10	Patternlines_ep	Cross Section Chain (Existing)	2	1 / DGN1	0
	rweng10	PayItem_dp	Pay Item Number Label Elements	4	0 / Continuous	2
X	rweng10	PlotBorder_dp	Plot Border	3	0 / Continuous	0
X	rweng10	PointLocator_ep	Point Locator Symbol (Existing)	4	0 / Continuous	0
X	rweng10	PropertyLine_ep	Existing:Property Line	7	0 / Continuous	0
X	rweng10	PropertyLineHook_ep	Cell:Miscellaneous:Property Line Hook	4	0 / Continuous	0
X	rweng10	PropertyLineLeader_ep	Annotation:Leader:Property Line (Existing)	7	RW-Leader / Continuous	0
X	rweng10	PropertyLineStaTie_ep	Annotation:Station Tie:Property Line (Existing)	7	RW-ArrowTie / Continuous	0
X	rweng10	PropertyLineSymbol_ep	Cell:Miscellaneous:Property Line Symbol	4	0 / Continuous	0
101	rweng10	PropertyLineText_ep	Annotation:Text:Property Line (Existing)	7	0 / Continuous	0
X	rweng10	ReferencePt_dp	Survey and Construction Reference Point Details and Elements	4	0 / Continuous	2
X	rweng10	RefPtAngleTie	Annotation: Angle Tie: Survey Reference Point / Detail	0	RW-Dimension-Type1 / Continuous	1
X	rweng10	RefPtLeader	Annotation: Leader: Survey Reference Point / Detail	0	RW-Leader / Continuous	1
X	rweng10	RefPtLine	Survey Reference Point Line / Detail (Miscellaneous)	0	0 / Continuous	1
X	rweng10	RefPtStaTie	Annotation: Station Tie: Survey Reference Point / Detail	0	RW-ArrowTie / Continuous	0
X	rweng10	RefPtText	Annotation: Text: Survey Data Reference (Miscellaneous) Point	0	0 / Continuous	1
X	rweng10	RFClipPoint	Cell:Miscellaneous:Point (Point Cell for RFCLIP Program)	4	0 / Continuous	10
X	rweng10	RRBaseline	Baseline:Rail Road Centerline	0	RW-RailroadeBL	0
X	rweng10	RRLeaderWt0	Annotation:Leader:Railroad (weight = 0)	0	RW-Leader / Continuous	0
X	rweng10	RRLeaderWt1	Annotation:Leader:Railroad (weight = 1)	0	RW-Leader / Continuous	1
X	rweng10	RRLeaderWt2	Annotation:Leader:Railroad (weight = 2)	0	RW-Leader / Continuous	2
101	rweng10	RRTextWt0	Annotation:Text:Railroad (weight = 0)	0	0 / Continuous	0
101	rweng10	RRTextWt1	Annotation:Text:Railroad (weight = 1)	0	0 / Continuous	1
101	rweng10	RRTextWt2	Annotation:Text:Railroad (weight = 2)	0	0 / Continuous	2
X	rweng10	RWandLA_Leader	Annotation:Leader:R/W & L/A (Proposed)	3	RW-Leader / Continuous	2
X	rweng10	RWandLA_Leader_ep	Annotation:Leader:R/W & L/A (Existing)	7	RW-Leader / Continuous	0
X	rweng10	RWandLA_StaTie	Annotation:Station Tie:R/W & L/A Lines (Proposed)	3	RW-ArrowTie / Continuous	2
X	rweng10	RWandLA_StaTie_ep	Annotation:Station Tie:R/W & L/A Lines (Existing)	7	RW-ArrowTie / Continuous	0
101	rweng10	RWandLA_Text	Annotation:Text:R/W & L/A Lines Taking Lines (Proposed )	3	0 / Continuous	2
101	rweng10	RWandLA_Text_ep	Annotation:Text:R/W & L/A Lines (Existing)	7	0 / Continuous	0
X	rweng10	RWandLA_WidthArrow	Annotation:Arrow:RW & LA Width (Proposed)	3	RW-Dimension-Type2 / Continuous	2
X	rweng10	RWandLA_WidthArrow_ep	Annotation:Arrow:RW & LA Width (Existing)	7	RW-Dimension-Type2 / Continuous	0
X	rweng10	RWLine	Proposed:Right of Way Line	4	RW-Proposed	3
X	rweng10	RWLine_ep	Existing:RW Line	7	RW-Existing	0
X	rweng10	Scale_dp	Bar Scale, Scale Label Elements	0	0 / Continuous	2
X	rweng10	Scratch1_dp	Scratch Level for Temporary or Informational Items	4	0 / Continuous	0
X	rweng10	Scratch2_dp	Scratch Level for Temporary or Informational Items	5	0 / Continuous	0

Critical	Rule	Level Name	Level Description	ByLevel Color	ByLevelStyle / Linetype	ByLevel Weight
X	rweng10	ScratchEle_dp	Scratch Level for Draft Elements, Temporary Elements, Etc. (DO NOT PLOT)	3	0 / Continuous	0
	rweng10	ScratchEle2_dp	Scratch Level for Draft Elements, Temporary Elements, Etc. (DO NOT PLOT)	4	0 / Continuous	0
X	rweng10	ScratchElements	Scratch:None Plotting Level for Draft Elements, Temporary Elements, Etc.	3	0 / Continuous	0
X	rweng10	ScratchLevel1	Scratch:Level for Undefined Items - weight of 1	0	0 / Continuous	1
X	rweng10	ScratchLevel2	Scratch:Level for Undefined Items - weight of 2	0	0 / Continuous	2
X	rweng10	ScratchLevel3	Scratch:Level for Undefined Items - weight of 3	0	0 / Continuous	3
101	rweng10	SegCurveData	Cell:Miscellaneous:Segmented Curve Data (Place on Text Symbology of Assoc. Element)	0	0 / Continuous	0
X	rweng10	SheetBorder_dp	Sheet Border	1	0 / Continuous	4
X	rweng10	SheetLines_dp	Sheet Lines	1	0 / Continuous	2
X	rweng10	SheetLinesMisc1_dp	Sheet Lines	1	0 / Continuous	0
X	rweng10	SheetLinesMisc2_dp	Sheet Lines	2	0 / Continuous	2
X	rweng10	SheetLinesMisc3_dp	Sheet Lines	3	0 / Continuous	2
X	rweng10	SheetLinesMisc4_dp	Sheet Lines	4	0 / Continuous	2
	rweng10	SheetLinesSignature_dp	Sheet Lines Signature	1	2 / DGN2	0
X	rweng10	SideStLeaderWt1	Annotation:Leader:Side Street (weight = 1)	0	RW-Leader / Continuous	1
X	rweng10	SideStLeaderWt2	Annotation:Leader:Side Street (weight = 2)	0	RW-Leader / Continuous	2
X	rweng10	SideStStaTie	Annotation:Station Tie:Side Street	0	RW-ArrowTie / Continuous	0
101	rweng10	SideStTextWt1	Annotation:Text:Side Street Curve Data, Curve & Coordinate Box Text	0	0 / Continuous	1
101	rweng10	SideStTextWt2	Annotation:Text:Side Street Data:Stations, Names, Leader Lines & Circles for (PC,PT,PI,POT)	0	0 / Continuous	2
X	rweng10	StationTicL_dp	Station Tic Marks (Large) and Text	0	0 / Continuous	2
X	rweng10	StationTicS_dp	Station Tic Marks (Small) and Text	0	0 / Continuous	2
101	rweng10	SubBlockNumberText	Cell:Miscellaneous:Subdivision:Text:Block Number Enter Data Field	5	0 / Continuous	2
X	rweng10	SubDivDelineator	Annotation:Subdivision Delineator Line for Subdivision Terminator	5	0 / Continuous	1
X	rweng10	SubDivLine	Existing:Subdivision Line	5	0 / Continuous	0
101	rweng10	SubDivLineText	Annotation:Text:Subdivision: Lines & Vacated / Original Lot Lines (Existing)	5	0 / Continuous	0
101	rweng10	SubDivNameText	Annotation:Text:Subdivision: Plat Name (Existing)	5	0 / Continuous	2
X	rweng10	SubDivRW_WidthArrow	Annotation:Arrow:Subdivision	5	RW-Dimension-Type2 / Continuous	0
X	rweng10	SubDoubleArrow	Annotation:Subdivision: Boundary Arrows Double <<---->>	5	RW-Subdiv-Double	1
101	rweng10	SubLotNumberText	Annotation:Text:Subdivision: Lot Numbers	5	0 / Continuous	1
X	rweng10	SubSingleArrow	Annotation:Subdivision: Boundary Arrows <---->	5	RW-Subdiv-Single / Continuous	1
X	rweng10	SubSingleLTArrow	Annotation:Subdivision: Boundary Arrows Single Left <----	5	RW-Subdiv-SingleLeft / Continuous	1
X	rweng10	SubSingleRTArrow	Annotation:Subdivision: Boundary Arrows Single Right ---->	5	RW-Subdiv-SingleRight / Continuous	1
X	rweng10	SubTwoLTArrow	Annotation:Subdivision: Boundary Arrows Two Left <<---->	5	RW-Subdiv-DoubleLeft / Continuous	1
X	rweng10	SubTwoLTOOnlyArrow	Annotation:Subdivision: Boundary Arrows Two Left Only <<----	5	RW-Subdiv-DoubleLeftOnly / Continuous	1
X	rweng10	SubTwoRTArrow	Annotation:Subdivision: Boundary Arrows Two Right <---->>	5	RW-Subdiv-DoubleRight / Continuous	1
X	rweng10	SubTwoRTOOnlyArrow	Annotation:Subdivision: Boundary Arrows Two Right Only ---->>	5	RW-Subdiv-DoubleRightOnly / Continuous	1
X	rweng10	SubVacOrigLotLeader	Annotation:Leader:Subdivision:Lines & Vacated / Original Lot Lines (Existing)	5	RW-Leader / Continuous	0
X	rweng10	SubVacOrigLotLine	Existing:Subdivision Vacated or Original Lot Line	5	5 / DGN5	0
X	rweng10	SubVacOrigLotStaTie	Annotation:Station Tie:Subdivision Vacated & Original Lot	5	RW-ArrowTie / Continuous	0
X	rweng10	SUEL_TIITF_Leader	Annotation:Leader:DEP:TIITF:Safe Upland Elevation Lines or Jurisdictional Lines	2	RW-Leader / Continuous	2
X	rweng10	SUEL_TIITF_Line	DEP:TIITF:Safe Upland Elevation Lines or Jurisdictional Lines established by DEP methodology	2	RW-PerpetualEasement	3
X	rweng10	SUEL_TIITF_StaTie	Annotation:Station Tie:DEP:TIITF:Safe Upland Elevation Lines or Jurisdictional Lines	2	RW-ArrowTie / Continuous	2
101	rweng10	SUEL_TIITF_Text	Annotation:Text:DEP:TIITF:Safe Upland Elevation Lines or Jurisdictional Lines	2	0 / Continuous	2
X	rweng10	SUEL_TIITF_WidthArrow	Annotation:Arrow:DEP:TIITF:Safe Upland Elevation Lines or Jurisdictional Lines	2	RW-Dimension-Type2 / Continuous	2

Critical	Rule	Level Name	Level Description	ByLevel Color	ByLevelStyle / Linetype	ByLevel Weight
	rweng10	Tables_dp	Data Tables and All Autodesk Tables	0	0 / Continuous	1
101	rweng10	TabOwnshpText	Annotation:Text:Miscellaneous: Table of Ownerships	0	0 / Continuous	1
	rweng10	TextDrainInvElev_ep	Text - Drainage Invert Elevation (Existing)	0	0 / Continuous	1
	rweng10	TextDrainLabel_ep	Text - Drainage (Existing)	0	0 / Continuous	1
X	rweng10	TextLabel	Text - Label	0	0 / Continuous	2
X	rweng10	TextMajor	Text - Major	0	0 / Continuous	5
X	rweng10	TextMinor	Text - Minor	0	0 / Continuous	0
X	rweng10	TextMisc	Text - Miscellaneous	0	0 / Continuous	1
X	rweng10	TextNotes	Text - Notes	4	0 / Continuous	1
X	rweng10	TextShtNo	Text - Sheet Number	0	0 / Continuous	2
	rweng10	TextSubUtilLabel_ep	Text - Subsurface Utilities (Existing)	0	0 / Continuous	1
101	rweng10	TextSurveyLabel	Text - Survey Labels	0	0 / Continuous	0
X	rweng10	TextTables	Text - Key Sheet Indexes and Table Data	4	0 / Continuous	2
X	rweng10	TextTitle	Text - Title	0	0 / Continuous	3
	rweng10	TextTopoLabel_ep	Text - Topography (Existing)	0	0 / Continuous	1
	rweng10	TextUtilLabel_ep	Text - Utilities (Existing)	0	0 / Continuous	1
X	rweng10	TopoMisc_ep	Topography (Miscellaneous) (Existing)	0	3 / DGN3	1
101	rweng10	TopoText_ep	Annotation:Text:Miscellaneous: All Other Topographic Element Labels (Reference Files)	0	0 / Continuous	0
	rweng10	Viewport	Viewport (For AutoCAD Use)	3	0 / Continuous	0
X	rweng10	WaterEdge	Annotation:Mapping Boundary for Rivers, Streams, or Lakes	7	RW-WaterMapBoundary / Continuous	0
	rweng10	Xreference01_dp	Reference Files (For AutoCAD Use)	0	0 / Continuous	1
	rweng10	Xreference02_dp	Reference Files (For AutoCAD Use)	0	0 / Continuous	1
	rweng10	Xreference03_dp	Reference Files (For AutoCAD Use)	0	0 / Continuous	1
	rweng10	Xreference04_dp	Reference Files (For AutoCAD Use)	0	0 / Continuous	1

## SPST10 - Structures

Critical	Rule File	Level Name	Level Description	ByLevel Color	ByLevelStyle / Linetype	ByLevel Weight	Plot?
100	spst10	ActivePts-ConstElements	Active Points & Drawing Construction Elements	99	0 / Continuous	0	No
100	spst10	AdhocPoint_dp	Adhoc Points Placed by SheetInfo	0	4 / DGN4	0	No
100	spst10	AppSlabConc	Concrete	2	0 / Continuous	3	Yes
100	spst10	AppSlabConc_h	Concrete Hidden	2	2 / DGN2	2	Yes
100	spst10	ArchBlocks	Architectural Blocks	0	0 / Continuous	0	Yes
100	spst10	BaseLineSurveyPGL	Baseline Survey or Profile Grade Line	3	6 / DGN6	0	Yes
100	spst10	BeamConc	Beams Concrete	2	0 / Continuous	3	Yes
100	spst10	BeamConc_h	Beams Concrete Hidden	2	2 / DGN2	2	Yes
	spst10	Bearings	Pot, Rocker, Masonry Plates	6	0 / Continuous	1	Yes
100	spst10	Bolts	Misc Bolts for Details	6	0 / Continuous	0	Yes
100	spst10	Bolts_h	Misc Bolts for Details - Hidden	6	1 / DGN1	0	Yes
100	spst10	Border	Border Elements & Text	0	0 / Continuous	1	Yes
100	spst10	Casework	Casework	1	0 / Continuous	1	Yes
100	spst10	Casework_h	Casework Hidden	1	3 / DGN3	0	Yes
100	spst10	Ceiling	Ceiling	0	0 / Continuous	1	Yes
100	spst10	Ceiling_h	Ceiling Hidden	0	3 / DGN3	0	Yes



Critical	Rule File	Level Name	Level Description	ByLevel Color	ByLevelStyle / Linetype	ByLevel Weight	Plot?
100	spst10	CL_ConsSurvey	Centerline Construction or Centerline Survey	3	7 / DGN7	0	Yes
100	spst10	CL_Major	Use as needed	3	7 / DGN7	0	Yes
100	spst10	CL_Minor	Use as needed	0	4 / DGN4	0	Yes
100	spst10	ConcArch_walls	Concrete Architectural Walls	1	0 / Continuous	2	Yes
100	spst10	ConcArch_walls_h	Concrete Architectural Walls Hidden	1	3 / DGN3	1	Yes
	spst10	ConstLines	Construction Lines and References	1	0 / Continuous	0	No
	spst10	ConstLines_pm	Construction Lines	4	0 / Continuous	0	No
100	spst10	CounterWeight	CounterWeight	2	0 / Continuous	0	Yes
100	spst10	CounterWeight_h	CounterWeight Hidden	2	2 / DGN2	2	Yes
100	spst10	DDConstruction	Dimension Driven Construction Lines	71	0 / Continuous	0	No
100	spst10	DDDDimensions	Dimension Driven Dimensions	71	0 / Continuous	0	No
100	spst10	DeckSteel	Steel Grid Bridge Decking	6	0 / Continuous	1	Yes
100	spst10	Dimension	Dimension Lines	0	0 / Continuous	0	Yes
100	spst10	Doors	Doors	1	0 / Continuous	1	Yes
100	spst10	Doors_h	Doors Hidden	1	3 / DGN3	0	Yes
100	spst10	DrainDeck	Scuppers, Deck Inlets	3	0 / Continuous	1	Yes
100	spst10	DrainMisc	Drainage Items (Miscellaneous)	10	0 / Continuous	1	Yes
100	spst10	DrainPipe	Drain Pipes PVC, Galvanized	10	0 / Continuous	1	Yes
100	spst10	DrShaftConc	Drilled Shaft Concrete	2	0 / Continuous	3	Yes
100	spst10	DrShaftConc_h	Drilled Shaft Concrete Hidden	2	2 / DGN2	2	Yes
100	spst10	ElectricalConduit	Electrical Conduit	7	0 / Continuous	0	Yes
100	spst10	ExistingMisc	Existing Misc.	3	1 / DGN1	0	Yes
100	spst10	ExistingRebar	Existing Reinforcing	84	1 / DGN1	0	Yes
100	spst10	ExistingUtility	Existing Utilities Electrical; FOC, Telephone, CableTV etc.	86	1 / DGN1	0	Yes
100	spst10	ExistSubStruct	Existing Bridge Substructure, Piers & Bents; Existing Piling	5	1 / DGN1	0	Yes
100	spst10	ExistSuperStruct	Existing Bridge Superstructure: Existing Beams & Diaphragms	5	1 / DGN1	0	Yes
	spst10	Ext_Misc	Exterior Miscellaneous	3	0 / Continuous	0	Yes
	spst10	Ext_Misc_h	Exterior Miscellaneous Hidden	3	3 / DGN3	0	Yes
100	spst10	Ext_Ornimental	Exterior Ornimentation	6	0 / Continuous	0	Yes
100	spst10	Ext_Ornimental_h	Exterior Ornimentation Hidden	6	3 / DGN3	0	Yes
100	spst10	Fascia	Fascia	4	0 / Continuous	1	Yes
100	spst10	Fascia_h	Fascia Hidden	4	3 / DGN3	0	Yes
100	spst10	FencePosts	Bridge Mounted Chain Link Fencing	6	0 / Continuous	1	Yes
100	spst10	Fencing	Bridge Mounted Chain Link Fencing	6	0 / Continuous	1	Yes
100	spst10	Fire_Equipment	Fire Equipment	1	0 / Continuous	1	Yes
100	spst10	Fire_Equipment_h	Fire Equipment Hidden	1	3 / DGN3	0	Yes
100	spst10	Floor	Floor	3	0 / Continuous	2	Yes
100	spst10	Floor_h	Floor Hidden	3	3 / DGN3	1	Yes
100	spst10	Furniture	Furniture	1	0 / Continuous	1	Yes
100	spst10	Furniture_h	Furniture Hidden	1	3 / DGN3	0	Yes
100	spst10	Glazing	Glazing	1	0 / Continuous	1	Yes
100	spst10	Glazing_h	Glazing Hidden	1	3 / DGN3	0	Yes
100	spst10	GroundLines	Proposed; Existing	2	0 / Continuous	1	Yes
	spst10	GSBWFill	GuidSign Black and White Fill Level for GuidSign Cells	0	0 / Continuous	1	Yes
	spst10	GSColorFill	GuidSign Color Fill Level for GuidSign Cells	2	0 / Continuous	1	Yes
	spst10	GSDims	GuidSign Dimensions	0	0 / Continuous	1	Yes
	spst10	GSOOutline	GuidSign Outline Level for GuidSign Cells	0	0 / Continuous	2	Yes
	spst10	GSSign	GuidSign Panel and Tag	7	0 / Continuous	0	Yes

Critical	Rule File	Level Name	Level Description	ByLevel Color	ByLevelStyle / Linetype	ByLevel Weight	Plot?
100	spst10	Guardrail	Guardrail and Post, Thrie and W Beam	1	0 / Continuous	1	Yes
100	spst10	Guardrail_h	Guardrail and Post, Thrie and W Beam -Hidden	1	1 / DGN1	1	Yes
100	spst10	Gypsum_board	Gypsum Board	1	0 / Continuous	1	Yes
100	spst10	Gypsum_board_h	Gypsum Board Hidden	1	3 / DGN3	0	Yes
100	spst10	HVAC_Equip	HVAC Equipment	5	0 / Continuous	2	Yes
100	spst10	HVAC_Equip_h	HVAC Equipment Hidden	5	5 / DGN5	1	Yes
100	spst10	HVAC_Misc	HVAC Miscellaneous	3	0 / Continuous	1	Yes
100	spst10	HVAC_Misc_h	HVAC Miscellaneous Hidden	3	5 / DGN5	0	Yes
100	spst10	HVAC_Return	HVAC Return	5	0 / Continuous	2	Yes
100	spst10	HVAC_Return_h	HVAC Return Hidden	5	2 / DGN2	1	Yes
100	spst10	HVAC_Supply	HVAC Supply	5	0 / Continuous	2	Yes
100	spst10	HVAC_Supply_h	HVAC Supply Hidden	5	3 / DGN3	1	Yes
100	spst10	Insulation	Insulation	3	0 / Continuous	1	Yes
100	spst10	Insulation_h	Insulation Hidden	3	3 / DGN3	0	Yes
100	spst10	Int_Mis_h	Interior Miscellaneous Hidden	3	3 / DGN3	0	Yes
100	spst10	Int_Misc	Interior Miscellaneous	3	0 / Continuous	1	Yes
100	spst10	Leader	Leader lines, Weld Symbols	0	0 / Continuous	0	Yes
100	spst10	LeafSteel	Leaf Structural Steel	6	0 / Continuous	0	Yes
100	spst10	LeafSteel_h	Leaf Structural Steel Hidden	6	2 / DGN2	2	Yes
100	spst10	Lighting	Lighting Bridge/Sign Mounted	31	0 / Continuous	0	Yes
100	spst10	Lighting_h	Lighting Bridge/Sign Mounted Hidden	31	2 / DGN2	0	Yes
100	spst10	LightingArch	Lighting Architectural	0	0 / Continuous	0	Yes
100	spst10	LightingArch_h	Lighting Architectural Hidden	0	0 / Continuous	2	Yes
100	spst10	MachineCompFixed	Machinery Components Fixed	7	0 / Continuous	2	Yes
100	spst10	MachineCompFixed_h	Machinery Components Fixed Hidden	7	2 / DGN2	1	Yes
100	spst10	MachineCompMoving	Machinery Components Moving	3	0 / Continuous	2	Yes
100	spst10	MachineCompMovng_h	Machinery Components Moving Hidden	3	2 / DGN2	1	Yes
100	spst10	MachineWeldments	Machine Weldments	4	0 / Continuous	2	Yes
100	spst10	MachineWeldments_h	Machine Weldments Hidden	4	2 / DGN2	1	Yes
100	spst10	Masonry	Masonry	3	0 / Continuous	1	Yes
100	spst10	Masonry_h	Masonry Hidden	3	3 / DGN3	0	Yes
100	spst10	Metal Framing	Metal Framing	4	0 / Continuous	1	Yes
100	spst10	Metal Framing_h	Metal Framing Hidden	4	3 / DGN3	0	Yes
	spst10	Miscellaneous	No defined symbology	3	0 / Continuous	1	Yes
100	spst10	NavLight	Navigational Lights	7	0 / Continuous	0	Yes
100	spst10	NavLight_h	Navigational Lights Hidden	7	2 / DGN2	0	Yes
	spst10	PadMisc	Bearing/Misc Pads	1	0 / Continuous	1	Yes
100	spst10	ParapetConc	Parapet Concrete	2	0 / Continuous	3	Yes
	spst10	Patterning	All; any	3	0 / Continuous	1	Yes
100	spst10	PayItem_dp	Pay Item Number Label Elements	4	0 / Continuous	2	Yes
100	spst10	PedRail	Pedestrian Rail, Bullet,Picket and Guidrail	3	0 / Continuous	1	Yes
100	spst10	PedRailMisc	Handrail Hardware Bullet,Picket and Guidrail	3	0 / Continuous	1	Yes
100	spst10	PileConc	Piles Concrete	2	0 / Continuous	3	Yes
100	spst10	PileConc_h	Piles Concrete Hidden	2	2 / DGN2	2	Yes
100	spst10	PilePlastic	Pile Plastic	1	0 / Continuous	1	Yes
100	spst10	PilePlastic_h	Pile Plastic Hidden	1	2 / DGN2	2	Yes
100	spst10	PileSteel	Piles Steel H-Piles & Pipe	6	0 / Continuous	1	Yes
100	spst10	PileSteel_h	Piles Steel H-Piles & Pipe Hidden	6	2 / DGN2	1	Yes



Critical	Rule File	Level Name	Level Description	ByLevel Color	ByLevelStyle / Linetype	ByLevel Weight	Plot?
100	spst10	PileTimber	Pile Timber	142	0 / Continuous	1	Yes
100	spst10	PileTimber_h	Pile Timber Hidden	142	2 / DGN2	1	Yes
100	spst10	PipeHydraulic	Hydraulic Pipe	7	0 / Continuous	1	Yes
100	spst10	PipeHydraulic_h	Hydraulic Pipe Hidden	7	2 / DGN2	0	Yes
100	spst10	PlotBorder_dp	Plot Border	3	0 / Continuous	0	Yes
100	spst10	Plumbing_Fixtures	Plumbing Fixtures	1	0 / Continuous	2	Yes
100	spst10	Plumbing_Fixtures_h	Plumbing Fixtures Hidden	1	5 / DGN5	1	Yes
100	spst10	Plumbing_Supply	Plumbing Supply	1	0 / Continuous	2	Yes
100	spst10	Plumbing_Supply_h	Plumbing Supply Hidden	1	3 / DGN3	1	Yes
100	spst10	Plumbing_Waste	Plumbing Waste	1	0 / Continuous	2	Yes
100	spst10	Plumbing_Waste_h	Plumbing Waste Hidden	1	2 / DGN2	1	Yes
100	spst10	PostTension	Post-Tensioning SteelStrands and Bars	6	0 / Continuous	1	Yes
100	spst10	PostTension_h	Post-Tensioning Steel HiddenStrands and Bars	6	2 / DGN2	1	Yes
	spst10	PostTension2	Post-Tensioning SteelStrands and Bars	46	0 / Continuous	1	Yes
	spst10	PostTension2_h	Post-Tensioning SteelStrands and Bars	46	0 / Continuous	1	Yes
	spst10	PostTension3	Post-Tensioning SteelStrands and Bars	46	0 / Continuous	1	Yes
	spst10	PostTension3_h	Post-Tensioning SteelStrands and Bars	46	0 / Continuous	1	Yes
100	spst10	PostTensionDucts	Post Tension Ducts Plastic and Metal	1	0 / Continuous	1	Yes
100	spst10	PostTensionGrout	Post Tension Grout	2	0 / Continuous	1	Yes
100	spst10	PostTensionMisc	Post Tensioning Hardware, Trumpets, Vents and Misc. Items	1	0 / Continuous	1	Yes
100	spst10	PrestressSteel	Prestressing Steel	36	0 / Continuous	1	Yes
100	spst10	PrestressSteel_h	Prestressing Steel Hidden	36	2 / DGN2	1	Yes
100	spst10	RailingArch	Railing Architectural	6	0 / Continuous	2	Yes
100	spst10	RailingArch_h	Railing Architectural Hidden	6	3 / DGN3	1	Yes
100	spst10	RailRoad	Rail road	3	RD-Railroad-Existing	0	Yes
100	spst10	Rebar	Reinforcing Major	4	0 / Continuous	1	Yes
	spst10	Rebar_h	Reinforcing Hidden	4	2 / DGN2	1	Yes
	spst10	Rebar10	Auxillary Rebar	4	0 / Continuous	1	Yes
	spst10	Rebar11	Auxillary Rebar	4	0 / Continuous	1	Yes
	spst10	Rebar2	Auxillary Rebar	4	0 / Continuous	1	Yes
	spst10	Rebar3	Auxillary Rebar	4	0 / Continuous	1	Yes
	spst10	Rebar4	Auxillary Rebar	4	0 / Continuous	1	Yes
	spst10	Rebar5	Auxillary Rebar	4	0 / Continuous	1	Yes
	spst10	Rebar6	Auxillary Rebar	4	0 / Continuous	1	Yes
	spst10	Rebar7	Auxillary Rebar	4	0 / Continuous	1	Yes
	spst10	Rebar8	Auxillary Rebar	4	0 / Continuous	1	Yes
	spst10	Rebar9	Auxillary Rebar	4	0 / Continuous	1	Yes
100	spst10	Roof_Misc	Roof Miscellaneous	3	0 / Continuous	1	Yes
100	spst10	Roof_Misc_h	Roof Miscellaneous Hidden	3	2 / DGN2	0	Yes
100	spst10	Roof_Structure	Roof Structure	4	0 / Continuous	2	Yes
100	spst10	Roof_Structure_h	Roof Structure Hidden	4	3 / DGN3	1	Yes
100	spst10	Roofing	Roofing	4	0 / Continuous	1	Yes
100	spst10	Roofing_h	Roofing Hidden	4	2 / DGN2	0	Yes
100	spst10	RW_Line	Right of Way lines	3	{ Chain Double-Dash } / Phantom	1	Yes
100	spst10	SchemElectric	Electrical Schematic	7	0 / Continuous	1	Yes
100	spst10	SchemElectricProp	Electrical Schematic Proposed	7	0 / Continuous	1	Yes
100	spst10	SchemHydraulicAux	Hydraulic Schematic Auxillary	4	0 / Continuous	1	Yes

Critical	Rule File	Level Name	Level Description	ByLevel Color	ByLevelStyle / Linetype	ByLevel Weight	Plot?
100	spst10	SchemHydraulicMain	Hydraulic Schematic Main	7	0 / Continuous	1	Yes
100	spst10	SchemTextLine	Schematic Text Line	0	0 / Continuous	1	Yes
100	spst10	SchemTextRung	Schematic Text Rung	4	0 / Continuous	1	Yes
100	spst10	SheetPileConc	Wall Sheet Precast	2	0 / Continuous	3	Yes
100	spst10	SheetPileConc_h	Wall Sheet Precast Hidden	2	2 / DGN2	2	Yes
100	spst10	SheetPileSteel	Wall Sheet Pile Steel	6	0 / Continuous	1	Yes
100	spst10	SheetPileSteel_h	Wall Sheet Pile Steel Hidden	6	2 / DGN2	2	Yes
100	spst10	Signage	Bridge Mounted Signs and Cantilever Sign Structures	6	0 / Continuous	1	Yes
100	spst10	Signage_h	Bridge Mounted Signs and Cantilever Sign Structures Hidden	6	2 / DGN2	1	Yes
100	spst10	SignageArch	Signage Architectural	0	0 / Continuous	1	Yes
100	spst10	SignageArch_h	Signage Architectural Hidden	0	3 / DGN3	0	Yes
100	spst10	SignMisc	Sign Miscellaneous Plates and Hardware	3	0 / Continuous	1	Yes
100	spst10	SignMisc_h	Sign Miscellaneous Plates and Hardware Hidden	3	2 / DGN2	1	Yes
100	spst10	SlopeProtection	Sand Cement Riprap, Slope Pavement; Rubble Riprap	3	0 / Continuous	3	Yes
100	spst10	SlopeProtection_h	Sand Cement Riprap, Slope Pavement; Rubble Riprap Hidden	3	2 / DGN2	3	Yes
100	spst10	Soffit	Soffit	4	0 / Continuous	1	Yes
100	spst10	Soffit_h	Soffit Hidden	4	3 / DGN3	0	Yes
100	spst10	Stairs	Stairs	6	0 / Continuous	2	Yes
100	spst10	Stairs_h	Stairs Hidden	6	3 / DGN3	1	Yes
100	spst10	SteelArch_Misc	Steel Architectural Miscellaneous	4	0 / Continuous	1	Yes
100	spst10	SteelArch_Misc_h	Steel Architectural Miscellaneous Hidden	4	3 / DGN3	0	Yes
100	spst10	SteelDiapXFram	Steel Diaphragms and Cross Frames	6	0 / Continuous	1	Yes
100	spst10	SteelDiapXFram_h	Steel Diaphragms and Cross Frames Hidden	6	2 / DGN2	0	Yes
100	spst10	SteelGirder	Steel Girder, Stringers, Trusses	6	0 / Continuous	1	Yes
100	spst10	SteelGirder_h	Steel Girder Stringers, Trusses Hidden,	6	2 / DGN2	0	Yes
100	spst10	SteelMisc	Steel Miscellaneous Stiffeners, Plates, Bolts etc.	6	0 / Continuous	1	Yes
100	spst10	SteelMisc_h	Steel Miscellaneous Hidden Stiffeners, Plates, Bolts etc.	6	2 / DGN2	0	Yes
	spst10	StrMisc	Structural Miscellaneous	3	0 / Continuous	1	Yes
	spst10	StrMisc_h	Structural Miscellaneous Hidden	3	2 / DGN2	1	Yes
	spst10	StrMiscConc	Structural Miscellaneous Concrete	2	0 / Continuous	3	Yes
	spst10	StrMiscConc_h	Structural Miscellaneous Concrete Hidden	2	2 / DGN2	2	Yes
100	spst10	Stucco	Stucco	1	0 / Continuous	0	Yes
100	spst10	Stucco_h	Stucco Hidden	1	3 / DGN3	0	Yes
100	spst10	SubStrConc	Substructure Concrete	2	0 / Continuous	3	Yes
100	spst10	SubStrConc_h	Substructure Concrete Hidden	2	2 / DGN2	3	Yes
100	spst10	SubStrConc2	Substructure Concrete Misc	2	0 / Continuous	3	Yes
100	spst10	SubStrConc2_h	Substructure Concrete Misc Hidden	2	2 / DGN2	3	Yes
100	spst10	SupstrConc	Concrete Deck, Segmental Box	2	0 / Continuous	3	Yes
100	spst10	SupstrConc_h	Concrete Deck, Segmental BoxHidden	2	2 / DGN2	2	Yes
100	spst10	SupstrConc2	Concrete Diaphragms, etc	2	0 / Continuous	3	Yes
100	spst10	SupstrConc2_h	Concrete Diaphragms, etc Hidden	2	2 / DGN2	2	Yes
100	spst10	Symbols	All Symbols not covered by Structures Site Menu	0	0 / Continuous	1	Yes
100	spst10	SymbolsElectric	Electrical Symbols	0	0 / Continuous	1	Yes
100	spst10	Tables	Data Tables and All Autodesk Tables	0	0 / Continuous	1	Yes
100	spst10	TextNotes	Text - Notes	0	0 / Continuous	0	Yes
100	spst10	TextRdwlyInitials	Text - Roadway Initials	0	0 / Continuous	1	Yes
100	spst10	TextStructShtNo	Sheet Number for Structures border sheet numbers	0	0 / Continuous	0	Yes
100	spst10	TextStructures	Structures Text	0	0 / Continuous	0	Yes

Critical	Rule File	Level Name	Level Description	ByLevel Color	ByLevelStyle / Linetype	Bylevel Weight	Plot?
100	spst10	TextStructuresLabel	Used By Sheet Navigator	0	0 / Continuous	0	Yes
100	spst10	TrafBarrierConc	Traffic Barrier Concrete	2	0 / Continuous	3	Yes
100	spst10	UtilityCableTV	UtilityCableTV	6	0 / Continuous	0	Yes
100	spst10	UtilityFiberOptics	UtilityFiberOptics	6	0 / Continuous	0	Yes
100	spst10	UtilityGasMain	UtilityGasMain	0	0 / Continuous	0	Yes
100	spst10	UtilityPower	UtilityPower	2	0 / Continuous	0	Yes
100	spst10	UtilitySewer	UtilitySewer	3	0 / Continuous	0	Yes
100	spst10	UtilityTelephone	UtilityTelephone	6	0 / Continuous	0	Yes
100	spst10	UtilityWater	UtilityWater	7	0 / Continuous	0	Yes
	spst10	Viewport	Viewport (for AutoCAD use)	3	0 / Continuous	0	No
100	spst10	Walkways-Ladders	Steel Ladder & Walkway Components; Timber, Steel, Plastic Landings & Catwalks	6	0 / Continuous	1	Yes
100	spst10	WallConc	Wall Coping Concrete	2	0 / Continuous	3	Yes
100	spst10	WallConc_h	Wall Coping Concrete Hidden	2	2 / DGN2	2	Yes
100	spst10	WallHardware	Wall Hardware	3	0 / Continuous	0	Yes
100	spst10	WallMSEPanel	Wall MSE Panels	2	0 / Continuous	3	Yes
100	spst10	WallMSEPanel_h	Wall MSE Panels Hidden	2	2 / DGN2	2	Yes
100	spst10	WallsArch	Interior Walls	6	0 / Continuous	2	Yes
100	spst10	WallsArch_h	Interior Walls Hidden	6	3 / DGN3	1	Yes
100	spst10	WallSoundConc	Precast Soundwall Concrete	2	0 / Continuous	3	Yes
100	spst10	WallSoundConc_h	Precast Soundwall Concrete Hidden	2	2 / DGN2	2	Yes
100	spst10	WallTempCritical	Wall Temporary Critical	3	0 / Continuous	1	Yes
100	spst10	WallTempCritical_h	Wall Temporary CriticalHidden	3	2 / DGN2	1	Yes
100	spst10	WaterLines	Water Line, Symbol	15	0 / Continuous	1	Yes
100	spst10	Whaler	Whalers, Timber,Plastic	142	0 / Continuous	1	Yes
100	spst10	Windows	Windows	3	0 / Continuous	2	Yes
100	spst10	Windows_h	Windows Hidden	3	3 / DGN3	1	Yes
100	spst10	Wood	Wood	142	0 / Continuous	1	Yes
100	spst10	Wood_h	Wood Hidden	142	3 / DGN3	0	Yes

## SURVRD - Survey Development Model

Critical	Rule File	Level Name	Level Description	ByLevel Color	ByLevelStyle / Linetype	Bylevel Weight	Point /Line	Feature Code
	survrd	ArchSite_ep	Archeological Site (Existing)	2	0 / Continuous	1	L	ARST
	survrd	Attenuator_ep	Attenuator Systems (Existing)	0	0 / Continuous	1	L	ATTN
	survrd	BankMent_ep	Embankment (Manmade, Top or Bottom) (Existing)	9	3 / DGN3	0	L	BNK
	survrd	BaselineSurvey	Baseline Survey	0	0 / Continuous	2	L	BL
	survrd	Basins_ep	Sediment Basin, Retention Pond (Existing)	10	3 / DGN3	1	L	BAS
	survrd	Beacons_ep	Beacons and Path Illumination (Existing)	0	0 / Continuous	1	P	BN
	survrd	BLSurveyCntrl_ep	Baseline Survey Control (Existing)	0	0 / Continuous	2	L	BLC
	survrd	BLSurveyField_ep	Baseline Field Survey (Calculated from BLC) (Existing)	0	0 / Continuous	2	L	BL
	survrd	BLSurveySymb_ep	Baseline Survey Symbol (Existing)	0	0 / Continuous	0		
	survrd	Bollard_ep	Bollards (Existing)	0	2 / DGN2	1	P	BOL
	survrd	BoxCulvert_ep	Box Culvert (Existing)	10	3 / DGN3	1	L	BXC
	survrd	Bridge_ep	Bridge Approaches and Slabs (Existing)	0	3 / DGN3	1	L	APRS
	survrd	BridgeEle_ep	Bridge Elements (Existing)	0	1 / DGN1	0	L	BRDG
X	survrd	Building_ep	Buildings (Existing)	1	0 / Continuous	0	L	BLDG

Critical	Rule File	Level Name	Level Description	ByLevel Color	ByLevelStyle / Linetype	Bylevel Weight	Point /Line	Feature Code
	survrd	BusStop_ep	Bench, Bus Stop (Existing)	8	1 / DGN1	0	P	BNCH
	survrd	CableBarrier_ep	Cable Barrier (Existing)	0	RD-CableBarrier	1	L	CBR
	survrd	Canal_ep	Canal, Lock (Existing)	7	3 / DGN3	0	L	CAN
	survrd	CattleGuard_ep	Cattle Guard (Existing)	7	1 / DGN1	0	P	CGD
	survrd	CATVAer_ep	Cable TV Line (Aerial) (Existing)	6	UT-OverheadCable-Existing	1	L	CATV
	survrd	CATVBurB_ep	Cable TV Line Quality Level B Locate (Buried) (Existing)	6	UT-BuriedCable-Existing(B)	1	L	BCATVB
	survrd	CATVBurC_ep	Cable TV Line Quality Level C Locate (Buried) (Existing)	6	UT-BuriedCable-Existing(C)	1	L	BCATVC
	survrd	CATVBurD_ep	Cable TV Line Quality Level D Locate (Buried) (Existing)	6	UT-BuriedCable-Existing(D)	1	L	BCATVD
	survrd	CATVCondBurB_ep	Cable TV Conduit System Quality Level B Locate (Buried) (Existing)	6	UT-BuriedCable-Existing(B)	1	L	CATVCB
	survrd	CATVCondBurC_ep	Cable TV Conduit System Quality Level C Locate (Buried) (Existing)	6	UT-BuriedCable-Existing(C)	1	L	CATVCC
	survrd	CATVCondBurD_ep	Cable TV Conduit System Quality Level D Locate (Buried) (Existing)	6	UT-BuriedCable-Existing(D)	1	L	CATVCD
	survrd	CATVMisc_ep	Cable TV Service Box and Miscellaneous, Pole (Existing)	6	1 / DGN1	1	P	CATVS
	survrd	CGBack_ep	Curb and Gutter (Back) (Existing)	4	3 / DGN3	0	L	CGB
	survrd	CGep_ep	Curb / Curb and Gutter (at EP & FL) (Existing)	0	3 / DGN3	0	L	CG
	survrd	CGFace_ep	Face of Curb and Gutter (Existing)	4	3 / DGN3	0	L	CGF
	survrd	ConcSlabs_ep	Concrete Slabs (Existing)	0	1 / DGN1	1	L	CSL
	survrd	ConduitB_ep	Utility Conduit & Encasements Quality Level B Locate (Existing)	3	UT-Casing-Existing(B)	1	L	DUCTB
	survrd	ConduitC_ep	Utility Conduit & Encasements Quality Level C Locate (Existing)	3	UT-Casing-Existing(C)	1	L	DUCTC
	survrd	ConduitD_ep	Utility Conduit & Encasements Quality Level D Locate (Existing)	3	UT-Casing-Existing(D)	1	L	DUCTD
	survrd	ConstLines	Construction Lines and References	1	0 / Continuous	0		
	survrd	ConstLines_pm	Construction Lines	4	0 / Continuous	0		
	survrd	Core_ep	Core Sample or Test Hole (Existing)	9	0 / Continuous	0	P	CSH
	survrd	CrossDrain_ep	Underdrains and Cross Drains (Existing)	10	3 / DGN3	1	L	UD
	survrd	CurbRamp_ep	Curb Cut Ramp (Existing)	2	3 / DGN3	0	L	CCR
	survrd	CurbRampWarning_ep	Detectable Warnings on Curb Ramps (Existing)	4	3 / DGN3	0	L	CRW
	survrd	CurveDataLabel_dp	Curve Data Labels PC,PI, PT	0	0 / Continuous	2		
	survrd	Deck_ep	Deck / Porch (Existing)	7	1 / DGN1	0	L	DECK
	survrd	DelineatorPost_ep	Delineator Post, Existing Metal and Flexible (Existing)	4	1 / DGN1	1	P	DLP
	survrd	Ditch_ep	Ditch (Top, Bottom and Flow Lines) (Existing)	7	6 / DGN6	0	L	DTCH
	survrd	DitchPavt_ep	Ditch Pavement (Existing)	0	1 / DGN1	0	L	DTCHP
	survrd	Docks_ep	Docks and Wharfs (Existing)	0	1 / DGN1	0	L	DOCK
	survrd	Dolphins_ep	Dolphins and Fenders (Existing)	7	1 / DGN1	0	P	DF
	survrd	DrainMisc_ep	Catch Basins (Existing)	10	3 / DGN3	1	L	CB
	survrd	DrainMisc_ep	Drainage Pipes and Spouts (Existing)	10	3 / DGN3	1	L	DRNP
	survrd	DrainMisc_ep	Drainage Junction Box (Existing)	10	3 / DGN3	1	L	JB
	survrd	DrainMisc_ep	Special Drainage Feature (Describe) (Existing)	10	3 / DGN3	1	L	SPD
	survrd	DrainMisc_ep	Spillways, Flumes or Scuppers (Existing)	10	3 / DGN3	1	L	SPL
	survrd	DrainMisc_ep	Yard Drain (Existing)	10	3 / DGN3	1	L	YD
	survrd	Driveway_ep	Driveway (Drive, Lane, Turnouts) (Existing)	7	3 / DGN3	0	L	DWY
X	survrd	DTM_ex	Digital Terrain Model on Cross Sections (Existing)	2	2 / DGN2	1		
X	survrd	DTMVertices_ep	Digital Terrain Model, Triangle Vertices (Existing)	0	0 / Continuous	1		
	survrd	DummyChains_ep	Dummy Chains (Existing)	0	0 / Continuous	1	L	DUMB
X	survrd	EaseLine_ep	Easement Lines (Existing)	1	RW-Easement	1		
X	survrd	EasePerpLine	Easement Lines Perpetual	4	RW-PerpetualEasement	1		
X	survrd	EaseTempLine_ep	Easement Lines Temporary (Existing)	6	RW-TemporaryEasement	1		
	survrd	ElecAer_ep	High Voltage Transmission Line (Existing)	3	UT-OverheadElec-Existing	1	L	HVL
	survrd	ElecAer_ep	Electrical Lines (Aerial) (Existing)	3	UT-OverheadElec-Existing	1	L	PWR
	survrd	ElecAerPri_ep	Conductors (Primary Distribution) (Aerial) (Existing)	3	UT-OverheadElec-Existing	1	L	PRI
	survrd	ElecAerSec_ep	Conductors (Secondary Distribution) (Aerial) (Existing)	3	UT-OverheadElec-Existing	1	L	SEC
	survrd	ElecBurB_ep	Electrical Quality Level B Locate (Buried) (Existing)	3	UT-BuriedElec-Existing(B)	1	L	BPWRB

Critical	Rule File	Level Name	Level Description	ByLevel Color	ByLevelStyle / Linetype	Bylevel Weight	Point /Line	Feature Code
	survrd	ElecBurC_ep	Electrical Quality Level C Locate (Buried) (Existing)	3	UT-BuriedElec-Existing(C)	1	L	BPWRC
	survrd	ElecBurCap_ep	Capacitors (Buried) (Existing)	3	1 / DGN1	1	L	CAPB
	survrd	ElecBurD_ep	Electrical Quality Level D Locate (Buried) (Existing)	3	UT-BuriedElec-Existing(D)	1	L	BPWRD
	survrd	ElecBurPriB_ep	Conductors (Primary Distribution) Quality Level B Locate (Buried) (Existing)	3	UT-BuriedElec-Existing(B)	1	L	TRANSB
	survrd	ElecBurPriC_ep	Conductors (Primary Distribution) Quality Level C Locate (Buried) (Existing)	3	UT-BuriedElec-Existing(C)	1	L	TRANSC
	survrd	ElecBurPriD_ep	Conductors (Primary Distribution) Quality Level D Locate (Buried) (Existing)	3	UT-BuriedElec-Existing(D)	1	L	TRANSD
	survrd	ElecBurSecB_ep	Conductor (Secondary Distribution) Quality Level B Locate (Buried) (Existing)	3	UT-BuriedElec-Existing(B)	1	L	BSECB
	survrd	ElecBurSecC_ep	Conductor (Secondary Distribution) Quality Level C Locate (Buried) (Existing)	3	UT-BuriedElec-Existing(C)	1	L	BSECC
	survrd	ElecBurSecD_ep	Conductor (Secondary Distribution) Quality Level D Locate (Buried) (Existing)	3	UT-BuriedElec-Existing(D)	1	L	BSECD
	survrd	ElecMisc_ep	Capacitors (Above Ground) (Existing)	3	1 / DGN1	1	L	CAPA
	survrd	ElecMisc_ep	Electric Service Box (Large) (Existing)	3	1 / DGN1	1	L	ELECS
	survrd	ElecMisc_ep	Fuses (Existing) (Existing)	3	1 / DGN1	1	L	FUSE
	survrd	ElecMisc_ep	Switchgear & Appurtenances (Existing)	3	1 / DGN1	1	L	SW
	survrd	ElecMisc_ep	Transformer (Existing)	3	1 / DGN1	1	P	TRNF
	survrd	ElecOutlet_ep	Electrical Outlet (Existing)	3	1 / DGN1	1	P	ELEO
	survrd	EndTreat_ep	Flared End Section (Existing)	10	3 / DGN3	1	L	FES
	survrd	EndTreat_ep	Mitered End Section (Existing)	10	3 / DGN3	1	L	MES
	survrd	EndTreat_ep	Straight Endwall (Existing)	10	3 / DGN3	1	L	SEW
	survrd	EndTreat_ep	Special Endwall (Existing)	10	3 / DGN3	1	L	SPEW
	survrd	EndTreat_ep	U-Type Endwall (Existing)	10	3 / DGN3	1	L	UEW
	survrd	EndTreat_ep	Winged End wall (Existing)	10	3 / DGN3	1	L	WEW
	survrd	Fence_ep	Fence (All) (Existing)	6	RD-Fence	0	L	FNC
	survrd	FireHydrant_ep	Fire Hydrant (Existing)	1	1 / DGN1	1	P	FH
	survrd	FloodLight_ep	Flood Light (Existing)	3	1 / DGN1	1	P	FLD
X	survrd	FlowArrow_ep	Digital Terrain Model, Triangle Flow Arrows (Existing)	10	0 / Continuous	1		
	survrd	FOCAer_ep	Fiber Optics Cable (Overhead)	6	UT-OverheadFOC-Existing	0	L	FOC
	survrd	FOCBurB_ep	Fiber Optics Cable (Underground) Quality Level B Locate	6	UT-BuriedFOC(B)-Existing	0	L	FOCUB
	survrd	FOCBurB_ep	Fiber Optics Cable (Underground) Quality Level B Locate	6	UT-BuriedFOC(B)-Existing	0	L	FOTVUB
	survrd	FOCBurB_ep	Fiber Optics Cable (Underground) Quality Level B Locate	6	UT-BuriedFOC(B)-Existing	0	L	FOUB
	survrd	FOCBurC_ep	Fiber Optics Cable (Underground) Quality Level C Locate	6	UT-BuriedFOC(C)-Existing	0	L	FOCUC
	survrd	FOCBurC_ep	Fiber Optics Cable (Underground) Quality Level C Locate	6	UT-BuriedFOC(C)-Existing	0	L	FOTVUC
	survrd	FOCBurC_ep	Fiber Optics Cable (Underground) Quality Level C Locate	6	UT-BuriedFOC(C)-Existing	0	L	FOUC
	survrd	FOCBurD_ep	Fiber Optics Cable (Underground) Quality Level D Locate	6	UT-BuriedFOC(D)-Existing	0	L	FOCUD
	survrd	FOCBurD_ep	Fiber Optics Cable (Underground) Quality Level D Locate	6	UT-BuriedFOC(D)-Existing	0	L	FOTVUD
	survrd	FOCBurD_ep	Fiber Optics Cable (Underground) Quality Level D Locate	6	UT-BuriedFOC(D)-Existing	0	L	FOUD
	survrd	FOEElecAer_ep	Fiber Optics Electrical (Aerial) (Existing)	3	UT-OverheadFOE-Existing	1	L	FOP
	survrd	FOEElecBurB_ep	Fiber Optics Electrical Quality Level B Locate (Buried) (Existing)	3	UT-BuriedFOE(B)-Existing	1	L	FOPUB
	survrd	FOEElecBurC_ep	Fiber Optics Electrical Quality Level C Locate (Buried) (Existing)	3	UT-BuriedFOE(C)-Existing	1	L	FOPUC
	survrd	FOEElecBurD_ep	Fiber Optics Electrical Quality Level D Locate (Buried) (Existing)	3	UT-BuriedFOE(D)-Existing	1	L	FOPUD
	survrd	FOTAer_ep	Fiber Optics Telephone (Aerial) (Size Unknown) (Existing)	6	UT-OverheadFOT-Existing	1	L	FO
	survrd	FOTBurB_ep	Fiber Optics Telephone Quality Level B Locate (Buried) (Size Unknown) (Existing)	6	UT-BuriedFOT(B)-Existing	1	L	FOUB
	survrd	FOTBurC_ep	Fiber Optics Telephone Quality Level C Locate (Buried) (Size Unknown) (Existing)	6	UT-BuriedFOT(C)-Existing	1	L	FOUC
	survrd	FOTBurD_ep	Fiber Optics Telephone Quality Level D Locate (Buried) (Size Unknown) (Existing)	6	UT-BuriedFOT(D)-Existing	1	L	FOUD
	survrd	Furnace_ep	Incinerator, Boiler, or Furnace (Existing)	8	1 / DGN1	0	P	INCN
	survrd	Gas_ep	Gas Test & Miscellaneous (Existing)	4	1 / DGN1	1	L	GTM
	survrd	GasB_ep	Gas Line (all sizes) Quality Level B Locate (Existing)	4	UT-Gas-Existing(B)	1	L	GASB
	survrd	GasC_ep	Gas Line (all sizes) Quality Level C Locate (Existing)	4	UT-Gas-Existing(C)	1	L	GASC

Critical	Rule File	Level Name	Level Description	ByLevel Color	ByLevelStyle / Linetype	ByLevel Weight	Point /Line	Feature Code
	survrd	GasD_ep	Gas Line (all sizes) Quality Level D Locate (Existing)	4	UT-Gas-Existing(D)	1	L	GASD
	survrd	GasReg_ep	Gas Regulator (Existing)	4	1 / DGN1	1	L	RG
	survrd	Gates_ep	Gates (Existing)	7	3 / DGN3	0	L	GT
	survrd	Gauges_ep	Gauges (Existing)	0	1 / DGN1	1	L	GA
	survrd	GlareScrn_ep	Glare Screen & Blinds (Existing)	0	{ curtain } / RD-Curtain	0	L	GS
	survrd	GovCityLimitLine_ep	Government:City Limit Line (Existing)	3	RW-CityLimit-Type 1	0		
	survrd	GovCountyLine_ep	Government:County Line (Existing)	3	RW-CountyLine	3		
	survrd	GovQuarterLine_ep	Government:Quarter Section Line (Existing)	3	RW-QuaterSection	1		
X	survrd	GovSectionLine_ep	Section Lines (Existing)	10	RW-SectionLine	2		
X	survrd	GovTwpRgeLine_ep	Township / Range Lines (Existing)	10	RW-TownshipRange	2		
	survrd	GroundShot_ep	Ground Shot for DTM Densification (Existing)	2	0 / Continuous	0	P	GND
	survrd	GuardrailDbl_ep	Guardrail Double Face (Existing)	0	RD-Guardrail-Double	0	L	GRDBL
	survrd	GuardrailLt_ep	Guardrail Left (Existing)	0	RD-Guardrail-Left	0	L	GRL
	survrd	GuardrailRt_ep	Guardrail Right (Existing)	0	RD-Guardrail-Right	0	L	GRR
	survrd	GuyWire_ep	Guy Anchor (Existing)	3	1 / DGN1	1	P	GYA
	survrd	GuyWire_ep	Guy Pole (Deadman) (Existing)	3	1 / DGN1	1	P	GYP
	survrd	GuyWire_ep	Span Guys (Existing)	3	1 / DGN1	1	L	GYS
	survrd	Hole_ep	Hole (Existing)	8	1 / DGN1	0	P	HOLE
	survrd	ImageAttachment_dp	Image Attachments	0	0 / Continuous	0		
	survrd	InletBottom_ep	Drainage Structure Bottoms (Existing)	10	3 / DGN3	1	L	DRNB
	survrd	InletCurb_ep	Curb Inlets (Existing)	10	3 / DGN3	1	L	CINL
	survrd	InletCurb_ep	Median Inlets (Existing)	10	3 / DGN3	1	L	MEDI
	survrd	InletDBI_ep	Ditch Bottom Inlet (Existing)	10	3 / DGN3	1	L	DTCHI
	survrd	InletGutter_ep	Gutter Inlets (All Types) (Existing)	10	3 / DGN3	1	L	GI
	survrd	JunctBox_ep	Junction Box / Service Cabinet (Elec/Tel) (Existing)	3	1 / DGN1	1	P	SRVC
	survrd	LaneLine_ep	Lane Lines (Existing)	0	RD-LaneLine-Existing	1	L	LL
X	survrd	LARWLine	Limited Access Right of Way Lines	4	RW-LimitedAccess-Proposed	2		
X	survrd	LARWLine_ep	Limited Access Right of Way Lines (Existing)	4	RW-LimitedAccess-Existing	1		
	survrd	LeaderLine_dp	Leader Line and Terminator with Text	0	0 / Continuous	1		
	survrd	LiteCond_ep	Street Lighting Conductors (Existing)	3	SG-Conduit-Existing	0	L	SLC
	survrd	Luminaire_ep	Street Light / Pole (Existing)	3	1 / DGN1	1	P	LP
	survrd	Mailbox_ep	Mailbox(s) (Existing)	8	1 / DGN1	0	P	MBX
	survrd	ManholeCOMM_ep	Manhole (Communications) (Existing)	6	1 / DGN1	1	P	MHCATV
	survrd	ManholeElec_ep	Manhole (Electric) (Existing)	3	1 / DGN1	1	P	MHE
	survrd	ManholeGas_ep	Manhole (Gas) (Existing)	4	1 / DGN1	1	P	MHG
	survrd	ManholeSS_ep	Manhole (Sanitary Sewer) (Existing)	2	1 / DGN1	1	P	MHS
	survrd	ManholeSW_ep	Manhole (Storm Water) (Existing)	10	1 / DGN1	0	P	MHD
	survrd	ManholeTel_ep	Manhole (Telephone) (Existing)	6	1 / DGN1	1	P	MHT
	survrd	ManholeUnknown_ep	Manhole (Unknown) (Existing)	0	1 / DGN1	1	P	MH
	survrd	ManholeWater_ep	Manhole (Water) (Existing)	1	1 / DGN1	1	P	MHW
	survrd	MeterElec_ep	Meter (Electric) (Existing)	3	1 / DGN1	1	P	ME
	survrd	MeterElecBur_ep	Meter (Electric) (Buried) (Existing)	3	1 / DGN1	1	P	MEU
	survrd	MeterGas_ep	Meter (Gas) (Existing)	4	1 / DGN1	1	P	MG
	survrd	MeterUnk_ep	Meter (Unknown) (Existing)	0	1 / DGN1	1	P	M
	survrd	MeterWater_ep	Meter (Water) (Existing)	1	1 / DGN1	1	P	MW
	survrd	MiscEquip_ep	Flag Pole (Existing)	8	1 / DGN1	0	P	FP
	survrd	MiscEquip_ep	Parking Meter (Existing)	8	1 / DGN1	0	P	PKGM
	survrd	Monument_ep	Aerial Targets (Existing)	4	0 / Continuous	0	P	AT
	survrd	Monument_ep	Concrete Monument (Cast) (Existing)	4	0 / Continuous	0	P	CMON
	survrd	Monument_ep	Drill Hole, Plug (Control Monumentation) (Existing)	4	0 / Continuous	0	P	DH



Critical	Rule File	Level Name	Level Description	ByLevel Color	ByLevelStyle / Linetype	Bylevel Weight	Point /Line	Feature Code
	survrd	Monument_ep	Deep Rod Mark (Existing)	4	0 / Continuous	0	P	DRM
	survrd	Monument_ep	5/8 Rod and Cap (Existing)	4	0 / Continuous	0	P	IRC
	survrd	Monument_ep	Nail, Spike, Pin (Control Monumentation) (Existing)	4	0 / Continuous	0	P	NL
	survrd	Monument_ep	Other Marker? (Control Monumentation) (Existing)	4	0 / Continuous	0	P	OM
	survrd	Monument_ep	Metal Pipe, Rod, Bar (Control) (Existing)	4	0 / Continuous	0	P	PIP
	survrd	Monument_ep	Concrete Monument (Poured) (Existing)	4	0 / Continuous	0	P	PMON
	survrd	Monument_ep	Post, Stake, Staub (Control Monumentation) (Existing)	4	0 / Continuous	0	P	PST
	survrd	Monument_ep	Hub and Tac (Existing)	4	0 / Continuous	0	P	SAT
	survrd	Monument_ep	Stamped Disk (Existing)	4	0 / Continuous	0	P	STMD
	survrd	Monument_ep	Stamped Plate (Existing)	4	0 / Continuous	0	P	STMP
	survrd	Oil_B_ep	Oil Line (All Sizes) Quality Level B Locate (Existing)	4	UT-Petroleum-Existing(B)	1	L	PETROB
	survrd	Oil_C_ep	Oil Line (All Sizes) Quality Level C Locate (Existing)	4	UT-Petroleum-Existing(C)	1	L	PETROC
	survrd	Oil_D_ep	Oil Line (All Sizes) Quality Level D Locate (Existing)	4	UT-Petroleum-Existing(D)	1	L	PETROD
	survrd	ParkEquip_ep	Campstove, Grill, Firepit, BBQ (Existing)	9	2 / DGN2	0	P	CM PST
	survrd	ParkEquip_ep	Playground Equipment (Existing)	9	2 / DGN2	0	P	PLEQ
	survrd	Patternlines_ep	Cross Section Chain (Existing)	2	1 / DGN1	0	L	XSC
	survrd	Pavemk_ep	Handicap Pavement Marking (Existing)	0	2 / DGN2	0	P	HNDC
	survrd	Pavemk_ep	Pavement Markings (Other) (Existing)	0	2 / DGN2	0	L	PMRK
	survrd	Pavemk_ep	Straight Direction Arrow (Existing)	0	2 / DGN2	0	P	STAROW
	survrd	Pavemk_ep	Straight and Turn Arrow (Existing)	0	2 / DGN2	0	P	STATRN
	survrd	Pavemk_ep	Turn Arrow (Existing)	0	2 / DGN2	0	P	TA
	survrd	PavtAsphalt_ep	Asphalt Pavement Edge (Existing)	0	3 / DGN3	1	L	AP
	survrd	PavtConcrete_ep	Concrete Pavement (Edges) (Existing)	0	3 / DGN3	1	L	CPVT
	survrd	PavtConcJoints_ep	Concrete Pavement (Joints) (Existing)	1	5 / DGN5	1	L	CPVJ
	survrd	PavtCrown_ep	Asphalt Pavement (Crown) (Existing)	0	4 / DGN4	1	L	AC
	survrd	PavtCrown_ep	Concrete Pavement (Crown) (Existing)	0	4 / DGN4	1	L	CPVC
	survrd	PavtMisc_ep	Pavement Parking Lot/Guardrail/Misc Pavement (Existing)	7	3 / DGN3	0	L	MP
	survrd	PavtTractorXing_ep	Tractor Crossings (Existing)	0	3 / DGN3	1	L	TX
	survrd	PavtXover_ep	Crossovers and Detours (Temporary) (Existing)	0	3 / DGN3	0	L	XO
	survrd	PedSignal_ep	Pedestrian Signal Unit, Signage (Existing)	0	2 / DGN2	0	P	PS
	survrd	Piling_ep	Piling, Piers, or Column (Existing)	8	3 / DGN3	0	P	PIL
	survrd	PipeCulvert_ep	Pipe Culvert (Existing)	10	3 / DGN3	1	L	PCULV
	survrd	PipeEncaseB_ep	Pipe Encasements Quality Level B Locate (Existing)	0	UT-Casing-Existing(B)	1	L	PIPENB
	survrd	PipeEncaseC_ep	Pipe Encasements Quality Level C Locate (Existing)	0	UT-Casing-Existing(C)	1	L	PIPENC
	survrd	PipeEncaseD_ep	Pipe Encasements Quality Level D Locate (Existing)	0	UT-Casing-Existing(D)	1	L	PIPEND
	survrd	PointLocator_ep	Point Locator Symbol (Existing)	4	0 / Continuous	0	P	
	survrd	PoleElec_ep	Electrical Pole (Existing)	3	1 / DGN1	1	P	PP
	survrd	PoleElec_ep	Electrical Pole With Transformer (Existing)	3	1 / DGN1	1	P	PPT
	survrd	PoleElec_ep	Shared Pole (Existing)	3	1 / DGN1	1	P	SHP
	survrd	PoleElec_ep	Shared Pole With Transformer (Existing)	3	1 / DGN1	1	P	SHPT
	survrd	PoleTel_ep	Telephone Pole (Existing)	6	1 / DGN1	1	P	TELP
X	survrd	PropertyLine_ep	Property Lines (Existing)	3	0 / Continuous	0		
	survrd	PullBox_ep	Wiring Pull Box (Existing)	3	1 / DGN1	1	P	WPB
	survrd	Pump_ep	Pump (Petroleum / Fuel) (Existing)	7	1 / DGN1	1	P	PMPF
	survrd	PumpIsland_ep	Pump Island (Existing)	7	3 / DGN3	1	L	PMPIS
	survrd	PumpNonPet_ep	Pump (Non Petroleum) (Existing)	1	1 / DGN1	1	P	PMP
	survrd	Railing_ep	Railings (All); Piperail, Guiderail, Handrail used for Pedestrian and Bicycles (Existing)	9	3 / DGN3	0	L	HNDRL
	survrd	RailroadMisc_ep	Railroad Milepost (Existing)	11	0 / Continuous	0	P	RRMP
	survrd	RailroadMisc_ep	Railroad Switch (Existing)	11	0 / Continuous	0	P	RRS

Critical	Rule File	Level Name	Level Description	ByLevel Color	ByLevelStyle / Linetype	Bylevel Weight	Point /Line	Feature Code
	survrd	RailroadMisc_ep	Railroad Warning Sign (Existing)	11	0 / Continuous	0	P	RRWS
	survrd	RailroadMisc_ep	Railroad Signal with Gate (Existing)	11	0 / Continuous	0	P	SWG
	survrd	RailroadTracks_ep	Railroad Tracks (Rail, Bed) (Existing)	4	3 / DGN3	0	L	RR
	survrd	RailroadXing_ep	Railroad Crossing (Roadway Platforms), Railroad Signal w/ Gate (Existing)	11	3 / DGN3	0	L	RRX
X	survrd	RefPtLine	Survey Reference Point Line / Detail (Miscellaneous)	0	0 / Continuous	1		
X	survrd	RefPtText	Annotation: Text: Survey Data Reference Point (Miscellaneous)	0	0 / Continuous	1		
	survrd	RipRap_ep	Rip Rap, Rubble (Existing)	4	3 / DGN3	1	L	RIP
	survrd	RRBaseline	Baseline:Rail Road Centerline	4	0 / Continuous	2	L	RRCL
X	survrd	RWLine	Right of Way Lines	4	RW-Proposed	2		
X	survrd	RWLine_ep	Right of Way Lines (Existing)	3	RW-Existing	1		
	survrd	SanitaryFM_B_ep	Force Main (All Sizes) Quality Level B Locate (Existing)	2	UT-Sanitary-Existing(B)	1	L	FMB
	survrd	SanitaryFM_C_ep	Force Main (All Sizes) Quality Level C Locate (Existing)	2	UT-Sanitary-Existing(C)	1	L	FMC
	survrd	SanitaryFM_D_ep	Force Main (All Sizes) Quality Level D Locate (Existing)	2	UT-Sanitary-Existing(D)	1	L	FMD
	survrd	SanitarySewerB_ep	Sanitary Sewer (All Sizes) Quality Level B Locate (Existing)	2	UT-Sanitary-Existing(B)	1	L	SSB
	survrd	SanitarySewerC_ep	Sanitary Sewer (All Sizes) Quality Level C Locate (Existing)	2	UT-Sanitary-Existing(C)	1	L	SSC
	survrd	SanitarySewerD_ep	Sanitary Sewer (All Sizes) Quality Level D Locate (Existing)	2	UT-Sanitary-Existing(D)	1	L	SSD
	survrd	SanitarySewerDSta_ep	Dump Station (SS) (Existing)	2	2 / DGN2	1	P	DMPS
	survrd	SanitarySewerMisc_ep	Cleanout (Existing)	2	1 / DGN1	1	P	CLNO
	survrd	SanitarySewerMisc_ep	Pump Station (Sanitary Sewer) (Existing)	2	1 / DGN1	1	P	PMPST
	survrd	SanitarySewerMisc_ep	Sanitary Effluent (Open Channel) (Existing)	2	1 / DGN1	1	L	SE
	survrd	SateDish_ep	Satellite Dish Antenna (Existing)	6	4 / DGN4	1	P	SATD
	survrd	Scratch1_dp	Scratch Level for Temporary or Informational Items	4	0 / Continuous	0		
	survrd	Scratch2_dp	Scratch Level for Temporary or Informational Items	5	0 / Continuous	0		
	survrd	ShldrPaved_ep	Shoulder Edge (Paved) (Existing)	1	3 / DGN3	0	L	SHLDR
	survrd	ShldrUnpaved_ep	Shoulders (Unpaved) (Existing)	0	3 / DGN3	0	L	UNPS
	survrd	Shrub_ep	Hedges and Shrubs (Boundary) (Existing)	2	0 / Continuous	0	L	HED
	survrd	Shrub_ep	Ornamental Plant (Existing)	2	0 / Continuous	0	P	OP
	survrd	Shrub_ep	Shrub, Bush (Existing)	2	0 / Continuous	0	P	SHR
	survrd	Shrub_ep	Coniferous Shrub (Existing)	2	0 / Continuous	0	P	SHRC
	survrd	Shrub_ep	Deciduous Shrub (Existing)	2	0 / Continuous	0	P	SHRD
	survrd	SidewalkBack_ep	Back of Sidewalk (Existing)	2	3 / DGN3	0	L	SWKB
	survrd	SidewalkFront_ep	Front of Sidewalk (Existing)	1	3 / DGN3	0	L	SWK
	survrd	Signal_ep	Signal Head (Existing)	3	1 / DGN1	1	P	SIG
	survrd	Signal_ep	Signal on Pedestal (Existing)	3	1 / DGN1	1	P	SIGP
	survrd	SignalLoop_ep	Traffic Detector Loops (Existing)	7	1 / DGN1	2	L	TFD
	survrd	SignalMisc_ep	Signal Equipment Including Control Unit (Miscellaneous) (Existing)	3	2 / DGN2	0	P	SIGC
	survrd	SignalSupport_ep	Signal Supports including Mast Arm (Existing)	3	2 / DGN2	0	P	SMA
	survrd	SignalSupport_ep	Support Mast Arm Extension (Existing)	3	2 / DGN2	0	L	SMAE
	survrd	SignMulti_ep	Multi-column Sign (Large Sign) (Existing)	0	3 / DGN3	1	L	MS
	survrd	SignSingle_ep	Sign (Single Support) (Existing)	3	2 / DGN2	0	P	SSS
	survrd	SignSupport_ep	Trusses and Cantilevers for Overhead Signs (Existing)	0	3 / DGN3	1	L	SGNT
	survrd	Silo_ep	Silo (Existing)	11	2 / DGN2	0	P	SILO
	survrd	Slopes_ep	Levees, Dikes, or Dams (Top or Bottom) (Existing)	9	3 / DGN3	0	L	LV
	survrd	Slopes_ep	Natural Slopes (Top or Bottom) (Existing)	9	3 / DGN3	0	L	SLP
	survrd	SpanWire_ep	Signal / Span Wire Pole (Existing)	3	2 / DGN2	0	P	SSP
	survrd	SpanWire_ep	Signal / Span Wire Pole (Existing)	3	2 / DGN2	0	L	SSW
	survrd	Sprinkler_ep	Sprinkler Head (Existing)	1	1 / DGN1	1	P	SPH
	survrd	Stairs_ep	Stairways, Steps (Existing)	0	3 / DGN3	1	L	STP
	survrd	StationTicL_dp	Station Tic Marks (Large) and Text	0	0 / Continuous	2		
	survrd	StationTicS_dp	Station Tic Marks (Small) and Text	0	0 / Continuous	2		



Critical	Rule File	Level Name	Level Description	ByLevel Color	ByLevelStyle / Linetype	Bylevel Weight	Point /Line	Feature Code
	survrd	SteamB_ep	Steam Line Quality Level B Locate (Existing)	4	UT-Steam-Existing(B)	1	L	STEAMB
	survrd	SteamC_ep	Steam Line Quality Level C Locate (Existing)	4	UT-Steam-Existing(C)	1	L	STEAMC
	survrd	SteamD_ep	Steam Line Quality Level D Locate (Existing)	4	UT-Steam-Existing(D)	1	L	STEAMD
	survrd	StormSewer_ep	Storm Sewer (All Sizes), Drain Pipes and Spouts (Existing)	10	3 / DGN3	1	L	STS
	survrd	Stream_ep	Stream Edge (Existing)	1	3 / DGN3	0	L	STRM
	survrd	Stream_ep	Stream Center (Existing)	1	3 / DGN3	0	L	STRMC
	survrd	StreamMisc_ep	Buoy (Existing)	7	0 / Continuous	0	P	BUOY
	survrd	StreamMisc_ep	Stream or Tide Gauge (Existing)	7	0 / Continuous	0	P	TG
	survrd	Stump_ep	Stump (Existing)	2	0 / Continuous	0	P	STM
	survrd	SU_Misc_ep	Subsurface Utilities (Miscellaneous) (Existing)	0	0 / Continuous	1	P	EOI
	survrd	SU_Misc_ep	Subsurface Utilities (Miscellaneous) (Existing)	0	0 / Continuous	1	P	QDEL
	survrd	SU_QLA_ep	Subsurface Utility Quality Level A Locate Point (Existing)	0	0 / Continuous	1	P	QLA
	survrd	SU_QLB_ep	Subsurface Utility Quality Level B Locate Point (Existing)	0	0 / Continuous	1	P	QLB
	survrd	SU_QLC_ep	Subsurface Utility Quality Level C Locate Point (Existing)	0	0 / Continuous	1	P	QLC
	survrd	SU_QLD_ep	Subsurface Utility Quality Level D Locate Point (Existing)	0	0 / Continuous	1	P	QLD
	survrd	SU_TestHole_ep	Subsurface Utility Test Hole (QLA Only) (Existing)	0	0 / Continuous	1	P	THA
	survrd	SubDivLine	Subdivision Line	5	0 / Continuous	0		
	survrd	Tables_dp	Data Tables and All Autodesk Tables	0	0 / Continuous	1		
	survrd	TankStor_ep	Storage Tank (Existing)	11	3 / DGN3	0	P	STTK
	survrd	TankUG_ep	Fill Cap (Buried Tank) (Existing)	3	1 / DGN1	0	P	FC
	survrd	TeleAer_ep	Telephone Line (Aerial) (Existing)	6	UT-OverheadTel-Existing	1	L	TEL
	survrd	TeleBurB_ep	Telephone ( All Sizes) Quality Level B Locate (Buried) (Existing)	6	UT-BuriedTel-Existing(B)	1	L	BTB
	survrd	TeleBurB_ep	Telephone ( All Sizes) Quality Level B Locate (Buried) (Existing)	6	UT-BuriedTel-Existing(B)	1	L	BTDB
	survrd	TeleBurB_ep	Telephone ( All Sizes) Quality Level B Locate (Buried) (Existing)	6	UT-BuriedTel-Existing(B)	1	L	BTTB
	survrd	TeleBurC_ep	Telephone ( All Sizes) Quality Level C Locate (Buried) (Existing)	6	UT-BuriedTel-Existing(C)	1	L	BTC
	survrd	TeleBurC_ep	Telephone ( All Sizes) Quality Level C Locate (Buried) (Existing)	6	UT-BuriedTel-Existing(C)	1	L	BTDC
	survrd	TeleBurC_ep	Telephone ( All Sizes) Quality Level C Locate (Buried) (Existing)	6	UT-BuriedTel-Existing(C)	1	L	BTTC
	survrd	TeleBurD_ep	Telephone ( All Sizes) Quality Level D Locate (Buried) (Existing)	6	UT-BuriedTel-Existing(D)	1	L	BTD
	survrd	TeleBurD_ep	Telephone ( All Sizes) Quality Level D Locate (Buried) (Existing)	6	UT-BuriedTel-Existing(D)	1	L	BTDD
	survrd	TeleBurD_ep	Telephone ( All Sizes) Quality Level D Locate (Buried) (Existing)	6	UT-BuriedTel-Existing(D)	1	L	BTTD
	survrd	TeleMisc_ep	Telephone Booth (Existing)	6	1 / DGN1	1	P	TB
	survrd	TeleMisc_ep	Telephone Service Box (Large) (Existing)	6	1 / DGN1	1	L	TELS
	survrd	TeleMisc_ep	Telephone Pedestal / Service (Existing)	6	1 / DGN1	1	P	TPD
	survrd	TextBLStation	Text - B/L Station and Tics	0	0 / Continuous	2		
	survrd	TextCurveData	Text - Curve Data Note	0	0 / Continuous	2		
	survrd	TextDrainInvElev_ep	Text - Drainage Invert Elevation (Existing)	0	0 / Continuous	1		
	survrd	TextDrainLabel_ep	Text - Drainage (Existing)	0	0 / Continuous	1		
	survrd	TextElevLabel	Text - Elevation Labels	4	0 / Continuous	0		
	survrd	TextLabel	Text - Label	0	0 / Continuous	2		
	survrd	TextMisc	Text - Miscellaneous	0	0 / Continuous	1		
	survrd	TextNotes	Text - Notes	4	0 / Continuous	1		
	survrd	TextPtLabel	Text - Point Labels	4	0 / Continuous	0		
	survrd	TextSubUtilLabel_ep	Text - Subsurface Utilities (Existing)	0	0 / Continuous	1		
	survrd	TextSurveyLabel	Survey Text Labels	0	0 / Continuous	0	P	MISC
	survrd	TextSurveyLabel	Survey Text Labels	0	0 / Continuous	0	P	NOTE
	survrd	TextSurveyLabel	Survey Text Labels	0	0 / Continuous	0		
	survrd	TextTopoLabel_ep	Text - Topography (Existing)	0	0 / Continuous	1		
	survrd	TextUtilLabel_ep	Text - Utilities (Existing)	0	0 / Continuous	1		
	survrd	TopoMisc_ep	Topography (Miscellaneous) (Existing)	0	3 / DGN3	1	L	MISC
	survrd	Tower_ep	Antenna (Existing)	3	1 / DGN1	1	P	ANT

Critical	Rule File	Level Name	Level Description	ByLevel Color	ByLevelStyle / Linetype	ByLevel Weight	Point /Line	Feature Code
	survrd	Tower_ep	Transmission Tower (Single Column) (Existing)	3	1 / DGN1	1	P	CLMT
	survrd	Tower_ep	High Mast Lighting Poles (Existing)	3	1 / DGN1	1	P	HML
	survrd	TrafSeparator_ep	Traffic Separator (Existing)	6	3 / DGN3	0	L	TFSP
	survrd	Trail_ep	Roadway,Trail (Unpaved) (Existing)	9	3 / DGN3	1	L	RD
	survrd	Trash_ep	Dumpster, Trash Disposal (Existing)	9	0 / Continuous	0	P	DMP
	survrd	Treadle_ep	Treadle (Existing)	7	1 / DGN1	5	L	TRD
	survrd	Tree_ep	Tree (Existing)	2	0 / Continuous	0	P	TREE
	survrd	Tree_ep	Coniferous Tree (Existing)	2	0 / Continuous	0	P	TREC
	survrd	Tree_ep	Citrus Tree (Existing)	2	0 / Continuous	0	P	TRECI
	survrd	Tree_ep	Cypress Tree (Existing)	2	0 / Continuous	0	P	TRECY
	survrd	Tree_ep	Deciduous Tree (Existing)	2	0 / Continuous	0	P	TREED
	survrd	Tree_ep	Oak Tree (Existing)	2	0 / Continuous	0	P	TREEOA
	survrd	Tree_ep	Palm Tree (Existing)	2	0 / Continuous	0	P	TREEPA
	survrd	Tree_ep	Palm Tree Cluster (Existing)	2	0 / Continuous	0	P	TREEPC
	survrd	Tree_ep	Pine Tree (Existing)	2	0 / Continuous	0	P	TREEPI
	survrd	TreeLine_ep	Groves & Orchards (Boundary) (Existing)	2	RD-TreeLine	0	L	GRV
	survrd	TreeLine_ep	Scattered Trees (Boundary) (Existing)	2	RD-TreeLine	0	L	SCT
	survrd	TreeLine_ep	Woods Line (Existing)	2	RD-TreeLine	0	L	WDL
	survrd	Tributary_ep	Spring (Water Source) (Existing)	1	0 / Continuous	0	P	SPR
	survrd	UnderDrain_ep	Under Drain Box (Existing)	10	3 / DGN3	0	P	UDBX
	survrd	UtilMisc_ep	Utility Items (Miscellaneous) (Existing)	0	0 / Continuous	0	L	
	survrd	Valve_ep	Valve Box (Existing)	0	1 / DGN1	1	P	VB
	survrd	Valve_ep	Valve (Existing)	0	1 / DGN1	1	P	VLV
	survrd	ValveBFP_ep	Valve (Back Flow Preventer), ValveBox (Existing)	0	1 / DGN1	1	P	VLVB
	survrd	ValveCover_ep	Valve Cover (Unknown) (Existing)	0	1 / DGN1	1	P	VC
	survrd	ValveCvrEff_ep	Valve Cover (Effluent) (Existing)	5	1 / DGN1	1	P	VCEF
	survrd	ValveCvrGas_ep	Valve Cover (Gas) (Existing)	4	1 / DGN1	1	P	VCG
	survrd	ValveCvrSewer_ep	Valve Cover (Sewer) (Existing)	2	1 / DGN1	1	P	VCS
	survrd	ValveCvrWater_ep	Valve Cover (Water) (Existing)	1	1 / DGN1	1	P	VCW
	survrd	ValveCvrWaterNP_ep	Valve Cover (Non-potable Water) (Existing)	5	1 / DGN1	1	P	VCNPW
	survrd	ValveCvrWaterNP_ep	Valve Cover (Raw Water) (Existing)	5	1 / DGN1	1	P	VCRW
	survrd	ValveGas_ep	Valve Box (Gas) (Existing)	4	1 / DGN1	1	P	VBG
	survrd	ValveGas_ep	Valve (Gas) (Existing)	4	1 / DGN1	1	P	VLVG
	survrd	ValveSewer_ep	Valve Box (Sewer) (Existing)	2	1 / DGN1	1	P	VBS
	survrd	ValveSewer_ep	Valve (Sewer) (Existing)	2	1 / DGN1	1	P	VLVS
	survrd	ValveWater_ep	Valve Box (Water) (Existing)	1	1 / DGN1	1	P	VBW
	survrd	ValveWater_ep	Valve (Water) (Existing)	1	1 / DGN1	1	P	VLVW
	survrd	ValveWaterNP_ep	Valve Box (Non-potable Water) (Existing)	5	1 / DGN1	1	P	VBNPW
	survrd	ValveWaterNP_ep	Valve (Non-potable Water) (Existing)	5	1 / DGN1	1	P	VLVNPW
	survrd	Vault_ep	Vaults Above Grade (Existing)	3	1 / DGN1	0	L	AGV
	survrd	Vault_ep	Vaults Below Grade (Existing)	3	1 / DGN1	0	L	BGV
	survrd	Vent_ep	Vent (Existing)	0	1 / DGN1	1	P	VNT
	survrd	VentGas_ep	Vent (Gas) (Existing)	4	1 / DGN1	1	P	VNTG
	survrd	VentSewer_ep	Vent (Sewer) (Existing)	2	1 / DGN1	1	P	VNTS
	survrd	Viewport	Viewport (For AutoCAD Use)	3	0 / Continuous	0		
	survrd	Wall_ep	Walls (Existing)	9	3 / DGN3	1	L	WALL
	survrd	WallBarrier_ep	Existing Wall Dividing Traffic (All) (Existing)	6	3 / DGN3	0	L	BARW
	survrd	WallBarrier_ep	Existing Wall Dividing Traffic (All) (Existing) (Temporary)	6	3 / DGN3	0	L	TMPW
	survrd	WallRetainEarth_ep	Existing Wall Holding Earth (All) (Existing)	6	3 / DGN3	0	L	RETW
	survrd	WallSea_ep	Sea Walls (Existing)	0	1 / DGN1	3	L	SEAW

Critical	Rule File	Level Name	Level Description	ByLevel Color	ByLevelStyle / Linetype	Bylevel Weight	Point /Line	Feature Code
	survrd	WaterB_ep	Water Line (All Sizes) Quality Level B Locate (Existing)	1	UT-Water-Existing(B)	1	L	WLB
	survrd	WaterC_ep	Water Line (All Sizes) Quality Level C Locate (Existing)	1	UT-Water-Existing(C)	1	L	WLC
	survrd	WaterD_ep	Water Line (All Sizes) Quality Level D Locate (Existing)	1	UT-Water-Existing(D)	1	L	WLD
	survrd	WaterEdge_ep	Edge of Water (Existing)	7	3 / DGN3	0	L	WEDG
	survrd	WaterMisc_ep	Faucet (Existing)	1	1 / DGN1	1	P	FAU
	survrd	WaterMisc_ep	Standpipe (Existing)	1	1 / DGN1	1	P	SP
	survrd	WaterNP_B_ep	Non-potable Water Line ( All Sizes) Quality Level B Locate (Existing)	5	UT-NonPotableWater-Existing(B)	1	L	NPWLB
	survrd	WaterNP_C_ep	Non-potable Water Line ( All Sizes) Quality Level C Locate (Existing)	5	UT-NonPotableWater-Existing(C)	1	L	NPWLC
	survrd	WaterNP_D_ep	Non-potable Water Line ( All Sizes) Quality Level D Locate (Existing)	5	UT-NonPotableWater-Existing(D)	1	L	NPWLD
	survrd	Well_ep	Well (Any Size) (Existing)	1	1 / DGN1	1	P	WELL
	survrd	WellMon_ep	Well Monitoring, Taps (Existing)	1	1 / DGN1	1	P	MONW
	survrd	Wetland_ep	W.M.D. & D.E.P. Wetlands (Existing)	1	RD-Wetland-Existing	0	L	DEP
	survrd	WetlandEdge_ep	CORPS Wetlands (Marsh or Swamp) (Existing)	2	RD-Wetland-Existing	0	L	COE
	survrd	WetlandEdge_ep	Edge of Mangrove (Existing)	2	RD-Wetland-Existing	0	L	EM
	survrd	WetlandEdge_ep	Edge of Wetlands (Marsh or Swamp) (Existing)	2	RD-Wetland-Existing	0	L	MAR
	survrd	WetlandSym_ep	Marsh Symbol (Existing)	2	1 / DGN1	0	P	MAR
	survrd	WetlandSym_ep	Wetland Point (Existing)	2	1 / DGN1	0	P	WLPT
	survrd	WindMill_ep	Wind Mill (Existing)	1	1 / DGN1	0	P	WIM
	survrd	Xreference01_dp	Reference Files (For AutoCAD Use)	0	0 / Continuous	1		
	survrd	Xreference02_dp	Reference Files (For AutoCAD Use)	0	0 / Continuous	1		
	survrd	Xreference03_dp	Reference Files (For AutoCAD Use)	0	0 / Continuous	1		
	survrd	Xreference04_dp	Reference Files (For AutoCAD Use)	0	0 / Continuous	1		
	survrd	XSpt_ep	Cross Section Point, Station (Existing)	2	1 / DGN1	0	P	XS

## TCDSRD - Traffic Control

Critical	Rule File	Level Name	Level Description	ByLevel Color	ByLevelStyle / Linetype	Bylevel Weight
	tcdsrd	ActivePointCell_dp	Active Point Cell	4	0 / Continuous	10
	tcdsrd	AdhocPoint_dp	Adhoc Points Placed by SheetInfo	0	4 / DGN4	0
X	tcdsrd	AdvWarnPanel	Advance Warning Arrow Panels	4	0 / Continuous	2
X	tcdsrd	AdvWarnVehicle	Work/Shadow/Advanced Warning Vehicle	3	0 / Continuous	2
X	tcdsrd	Aggregate	Aggregate	8	0 / Continuous	1
X	tcdsrd	ArtificialCovering	Artificial Coverings	10	0 / Continuous	2
X	tcdsrd	Attenuator	Attenuator Systems	6	MOT-Attenuator	1
X	tcdsrd	AttenuatorTM	Attenuator Truck Mount	6	0 / Continuous	2
X	tcdsrd	Barricade_px	Barricades Type I and II, Vertical Panels on Typical	6	0 / Continuous	2
X	tcdsrd	BarricadeIII	Barricade Type III	6	0 / Continuous	2
X	tcdsrd	BarricadeIII_px	Barricade Type III on Typical	6	0 / Continuous	2
	tcdsrd	BaselineSurvey	Baseline Survey	0	0 / Continuous	2
X	tcdsrd	Bridge	Bridge	0	0 / Continuous	2
X	tcdsrd	CandG_ex	Curb and Gutter on Cross Sections (All Types) (Existing)	4	2 / DGN2	1
X	tcdsrd	CandG_px	Curb and Gutter on Cross Sections (All Types)	4	0 / Continuous	2
X	tcdsrd	CandGBase_px	Curb and Gutter Base on Cross Sections	3	0 / Continuous	1
X	tcdsrd	ChannelDev	Channelizing Devices	0	0 / Continuous	2
X	tcdsrd	ChannelDevPed	Longitudinal Channelizing Device for Pedestrians	6	MOT-ChannelDevPed	2
X	tcdsrd	ChannelDevPed_px	Longitudinal Channelizing Device for Pedestrians on Typical	6	0 / Continuous	2

Critical	Rule File	Level Name	Level Description	ByLevel Color	ByLevelStyle / Linetype	ByLevel Weight
	tcdsrd	CLConst_dp	Center Line of Construction	0	0 / Continuous	2
	tcdsrd	ClipBorder_dp	CLIP Border and Civil 3D View Frame	3	0 / Continuous	0
	tcdsrd	ClipDrawingBound_dp	CLIP Drawing Boundary	3	3 / Continuous	0
	tcdsrd	Cloud_dp	Construction Cloud	7	0 / Continuous	2
X	tcdsrd	CmpFlashbrdRiser	Cmp Flashboard Riser	10	0 / Continuous	2
	tcdsrd	COGO_dp	COGO Information	3	0 / Continuous	1
X	tcdsrd	Concrete	Concrete Areas and Miscellaneous (All Types)	0	0 / Continuous	2
X	tcdsrd	ConcSlabs	Concrete Slabs	0	0 / Continuous	2
X	tcdsrd	Cone_px	Cone and Tubular Marker on Typical	6	0 / Continuous	2
	tcdsrd	ConstArea_dp	Construction Area Crosshatch	0	0 / Continuous	1
	tcdsrd	ConstLimits	Construction Limits	3	RW-LimitsofConst	2
	tcdsrd	ConstLines	Construction Lines and References	1	0 / Continuous	0
	tcdsrd	ConstLines_pm	Construction Lines	4	0 / Continuous	0
X	tcdsrd	CrossWalk1	Emphasis Crosswalk 6ft High	0	PM-Stripe-6' Crosswalk	4
X	tcdsrd	CrossWalk2	Emphasis Crosswalk 10ft High	0	PM-Stripe-10' Crosswalk	4
X	tcdsrd	CurbBack	Back of Curb	4	0 / Continuous	1
X	tcdsrd	CurbFace	Curb and Gutter (Face)	4	0 / Continuous	1
X	tcdsrd	CurbRamp	Curb Cut Ramp	8	0 / Continuous	1
	tcdsrd	CurveData_dp	Curve and Coordinate Data Elements Including PC, PT, PI Symbols	4	0 / Continuous	2
	tcdsrd	CurveDataLabel_dp	Curve Data Labels PC, PI, PT	0	0 / Continuous	2
X	tcdsrd	Delineator	Delineators (All Types)	4	0 / Continuous	1
	tcdsrd	DimLines_dp	Dimension Lines, Corresponding Terminators, Equation Lines	0	0 / Continuous	1
X	tcdsrd	DirArrowsPavt	Pavement Marking Directional Arrows	0	0 / Continuous	1
X	tcdsrd	Ditch	Ditch Top	7	6 / DGN6	1
X	tcdsrd	DitchBot	Ditch Bottom	10	0 / Continuous	2
X	tcdsrd	DitchPavt	Ditch Pavement Including Quantity Shapes	3	0 / Continuous	1
	tcdsrd	DitchProfLt_er	Ditch Profile Left (Existing)	8	3 / DGN3	1
	tcdsrd	DitchProfLt_pr	Ditch Profile Left	8	0 / Continuous	1
	tcdsrd	DitchProfMdn_er	Ditch Profile Median (Existing)	10	3 / DGN3	1
	tcdsrd	DitchProfMdn_pr	Ditch Profile Median	10	0 / Continuous	1
	tcdsrd	DitchProfRt_er	Ditch Profile Right (Existing)	9	3 / DGN3	1
	tcdsrd	DitchProfRt_pr	Ditch Profile Right	9	0 / Continuous	1
	tcdsrd	DrainDivideArw	Drainage Divide Arrow	0	0 / Continuous	1
	tcdsrd	DrainDivides00	Drainage Divides	10	2 / DGN2	4
	tcdsrd	DrainDivides00_ep	Drainage Divides (Existing)	9	2 / DGN2	4
	tcdsrd	DrainDivides01	Drainage Divides	10	2 / DGN2	4
	tcdsrd	DrainDivides01_ep	Drainage Divides (Existing)	9	2 / DGN2	4
	tcdsrd	DrainDivides02	Drainage Divides	10	2 / DGN2	4
	tcdsrd	DrainDivides02_ep	Drainage Divides (Existing)	9	2 / DGN2	4
	tcdsrd	DrainDivides03	Drainage Divides	10	2 / DGN2	4
	tcdsrd	DrainDivides03_ep	Drainage Divides (Existing)	9	2 / DGN2	4
	tcdsrd	DrainDivides04	Drainage Divides	10	2 / DGN2	4
	tcdsrd	DrainDivides04_ep	Drainage Divides (Existing)	9	2 / DGN2	4
	tcdsrd	DrainDivides05	Drainage Divides	10	2 / DGN2	4
	tcdsrd	DrainDivides05_ep	Drainage Divides (Existing)	9	2 / DGN2	4
	tcdsrd	DrainDivides06	Drainage Divides	10	2 / DGN2	4

Critical	Rule File	Level Name	Level Description	ByLevel Color	ByLevelStyle / Linetype	Bylevel Weight
	tcdsr	DrainDivides06_ep	Drainage Divides (Existing)	9	2 / DGN2	4
	tcdsr	DrainDivides07	Drainage Divides	10	2 / DGN2	4
	tcdsr	DrainDivides07_ep	Drainage Divides (Existing)	9	2 / DGN2	4
	tcdsr	DrainDivides08	Drainage Divides	10	2 / DGN2	4
	tcdsr	DrainDivides08_ep	Drainage Divides (Existing)	9	2 / DGN2	4
	tcdsr	DrainDivides09	Drainage Divides	10	2 / DGN2	4
	tcdsr	DrainDivides09_ep	Drainage Divides (Existing)	9	2 / DGN2	4
	tcdsr	DrainMisc	Drainage Items (Miscellaneous)	10	0 / Continuous	1
	tcdsr	DrainMisc_pm	Drainage Items (Proposed Model) (Miscellaneous)	10	0 / Continuous	1
X	tcdsr	DrainStruct	Drainage Structure in Plan	10	2 / DGN2	
X	tcdsr	DrainStruct_pr	Drainage Structures (All Types)	10	0 / Continuous	2
X	tcdsr	DrainStruct_px	Drainage Structures and Elements on Cross Sections (Miscellaneous)	10	0 / Continuous	2
	tcdsr	Drum_px	Drum on Typical	6	0 / Continuous	2
X	tcdsr	EaseLicLine	Easement License Agreement Line	5	6 / DGN6	0
X	tcdsr	EasePerpLine	Easement Lines Perpetual	4	RW-PerpetualEasement	1
X	tcdsr	EaseTempLine	Easement Lines Temporary	6	RW-TemporaryEasement	0
X	tcdsr	Fence	Fence, Sand Fence	6	RD-Fence	1
X	tcdsr	FenceLt	Fence - Limited Access Left	6	RD-Fence	1
X	tcdsr	FenceRt	Fence - Limited Access Right	6	RD-Fence	1
X	tcdsr	Flagman	Flagman	6	0 / Continuous	2
X	tcdsr	FlowPaths	Time of Concentration Flow Paths	10	1 / DGN1	1
X	tcdsr	Gabions	Gabion Baskets or Mats	10	0 / Continuous	2
X	tcdsr	Gabions_ep	Gabion Baskets or Mats (Existing)	10	1 / DGN1	2
X	tcdsr	GovTwpRgeLine_ep	Township / Range Lines (Existing)	10	RW-TownshipRange	2
X	tcdsr	Grass	Grass, Seeding and Mulching Areas	2	1 / DGN1	2
	tcdsr	GridMaj_dp	Grid Lines Major in Profile and Cross Section	3	0 / Continuous	1
	tcdsr	GridMin_dp	Grid Lines Minor in Profile and Cross Section	0	0 / Continuous	0
	tcdsr	GridMinSub_dp	Grid Lines Minor Sub on Cross Section Sheets	20	0 / Continuous	0
X	tcdsr	Guardrail	Guardrail	1	0 / Continuous	1
X	tcdsr	GuardrailBRLt	Guardrail Bridge (Left)	0	RD-Guardrail-Left	1
X	tcdsr	GuardrailBRRt	Guardrail Bridge (Right)	0	RD-Guardrail-Right	1
X	tcdsr	GuardrailDbl	Guardrail (Double Face)	0	RD-Guardrail-Double	1
X	tcdsr	GuardrailEndAch	Guardrail (End Anchorage)	0	0 / Continuous	1
X	tcdsr	GuardrailLt	Guardrail (Left)	0	RD-Guardrail-Left	1
X	tcdsr	GuardrailModThrieDbl	Guardrail Modified Thrie Beam (Double Face)	0	RD-Guardrail-Double	1
X	tcdsr	GuardrailModThrieLt	Guardrail Modified Thrie Beam (Left)	0	RD-Guardrail-Left	1
X	tcdsr	GuardrailModThrieRt	Guardrail Modified Thrie Beam (Right)	0	RD-Guardrail-Right	1
X	tcdsr	GuardrailPanel_px	Guardrail Component Property on Cross Sections for 3D Guardrail Panels	11	0 / Continuous	1
X	tcdsr	GuardrailPost_px	Guardrail Component Property on Cross Sections for 3D Guardrail Posts	10	0 / Continuous	0
X	tcdsr	GuardrailPRDbl	Guardrail Double Face w/ Pipe Rail	0	RD-Guardrail-Double	1
X	tcdsr	GuardrailPRLt	Guardrail Left w/ Pipe Rail	0	RD-Guardrail-Left	1
X	tcdsr	GuardrailPRRt	Guardrail Right w/ Pipe Rail	0	RD-Guardrail-Right	1
X	tcdsr	GuardrailRRDbl	Guardrail Double Face w/ Rub Rail	0	RD-Guardrail-Double	1
X	tcdsr	GuardrailRRLt	Guardrail Left w/ Rub Rail	0	RD-Guardrail-Left	1
X	tcdsr	GuardrailRRRt	Guardrail Right w/ Rub Rail	0	RD-Guardrail-Right	1
X	tcdsr	GuardrailRt	Guardrail Right	0	RD-Guardrail-Right	1

Critical	Rule File	Level Name	Level Description	ByLevel Color	ByLevelStyle / Linetype	Bylevel Weight
X	tcdsrd	GuardrailThrieDbl	Guardrail Thrie Beam Double Face	0	RD-Guardrail-Double	1
X	tcdsrd	GuardrailThrieLt	Guardrail Thrie Beam Left	0	RD-Guardrail-Left	1
X	tcdsrd	GuardrailThriePRLt	Guardrail Thrie Beam Left w/ Pipe Rail	0	RD-Guardrail-Left	1
X	tcdsrd	GuardrailThriePRRt	Guardrail Thrie Beam Right w/ Pipe Rail	0	RD-Guardrail-Right	1
X	tcdsrd	GuardrailThrieRt	Guardrail Thrie Beam Right	0	RD-Guardrail-Right	1
X	tcdsrd	GuyWire	Guy Wire	3	0 / Continuous	2
	tcdsrd	HardscapeDetails	Paving Details, Fence Railing, Stamped Asphalt	4	0 / Continuous	2
	tcdsrd	ImageAttachment_dp	Image Attachments	0	0 / Continuous	0
X	tcdsrd	InletProt	Rock Bags and Sand Bagging	10	SWP-RockBags	2
	tcdsrd	KeyShtMisc	Key Sheet Items (Miscellaneous)	0	0 / Continuous	2
X	tcdsrd	LARWLine	Limited Access Right of Way Lines	4	RW-LimitedAccess-Proposed	2
X	tcdsrd	LARWLine_ep	Limited Access Right of Way Lines (Existing)	4	RW-LimitedAccess-Existing	1
	tcdsrd	LeaderLine_dp	Leader Line and Terminator with Text	0	0 / Continuous	1
	tcdsrd	Logo_dp	Consultant Engineer of Record Logo	0	0 / Continuous	1
	tcdsrd	MatchLines_dp	Match Lines with Text, Arrows for Station Notations	1	0 / Continuous	2
	tcdsrd	Miscellaneous0	Undefined Proposed Item - Color Blue Weight 0	1	0 / Continuous	0
	tcdsrd	Miscellaneous1	Undefined Proposed Item - Color Blue Weight 1	1	0 / Continuous	1
	tcdsrd	Miscellaneous2	Undefined Proposed Item - Color Blue Weight 2	1	0 / Continuous	2
	tcdsrd	Miscellaneous3	Undefined Proposed Item - Color Green Weight 0	2	0 / Continuous	0
	tcdsrd	Miscellaneous4	Undefined Proposed Item - Color Green Weight 1	2	0 / Continuous	1
	tcdsrd	Miscellaneous5	Undefined Proposed Item - Color Green Weight 2	2	0 / Continuous	2
	tcdsrd	Miscellaneous6	Undefined Proposed Item - Color Red Weight 0	3	0 / Continuous	0
	tcdsrd	Miscellaneous7	Undefined Proposed Item - Color Red Weight 1	3	0 / Continuous	1
	tcdsrd	Miscellaneous8	Undefined Proposed Item - Color Red Weight 2	3	0 / Continuous	2
	tcdsrd	Miscellaneous9	Undefined Proposed Item - Color Red Weight 3	3	0 / Continuous	3
	tcdsrd	NonPlottingEle_dp	Non-Plotting Items - Construction Elements, Type 66 Elements, Etc.	4	0 / Continuous	0
	tcdsrd	NorthArw_dp	North Arrows	0	0 / Continuous	2
X	tcdsrd	ObjectMarker	Object and Reflective Markers	3	0 / Continuous	1
X	tcdsrd	OverheadSign	Overhead Sign Panels	0	0 / Continuous	2
X	tcdsrd	OverheadSign_ep	Overhead Sign Panels (Existing)	0	3 / DGN3	1
X	tcdsrd	OverheadStr	Mast Arm, Truss Assemblies, Signal Arms and Supports	0	0 / Continuous	2
X	tcdsrd	OverheadStr_ep	Mast Arm, Truss Assemblies, Signal Arms and Supports (Existing)	0	3 / DGN3	1
X	tcdsrd	PavtBase	Base Material (All Types)	3	0 / Continuous	2
X	tcdsrd	PavtConcreteSC	Concrete Surface Coloring	9	0 / Continuous	1
X	tcdsrd	PavtMessage	Pavement Message (All Types)	0	0 / Continuous	1
X	tcdsrd	PavtMessage_ep	Pavement Message (All Types) (Existing)	0	2 / DGN2	0
	tcdsrd	PavtMisc	Asphalt Material (Miscellaneous)	1	0 / Continuous	1
X	tcdsrd	PavtStabilization	Stabilization Material Lines and Shapes	9	0 / Continuous	2
	tcdsrd	PavtXover_ep	Crossovers and Detours (Temporary) (Existing)	0	3 / DGN3	0
	tcdsrd	PayItem_dp	Pay Item Number Label Elements	4	0 / Continuous	2
X	tcdsrd	PedDetector	Pedestrian Detector	0	0 / Continuous	2
X	tcdsrd	Pedestal	Pedestal	1	0 / Continuous	1
X	tcdsrd	Pedestal_ep	Pedestal (Existing)	1	2 / DGN2	1
X	tcdsrd	PedHead	Pedestrian Head (All Types)	1	0 / Continuous	1
X	tcdsrd	PedHead_ep	Pedestrian Head (All Types) (Existing)	0	2 / DGN2	1
X	tcdsrd	PipeCulvert	Pipe Culvert in Plan	10	2 / DGN2	2



Critical	Rule File	Level Name	Level Description	ByLevel Color	ByLevelStyle / Linetype	Bylevel Weight
X	tcdsrd	PlotBorder_dp	Plot Border	3	0 / Continuous	0
X	tcdsrd	PMCeramic	Pavement Markers Ceramic	0	0 / Continuous	1
	tcdsrd	PMMisc	Pavement Marking Items (Miscellaneous)	0	0 / Continuous	2
X	tcdsrd	PMStripe(10-10-20)	Pavement Marking 10/10/20 Skip Traffic Stripe 6in Contrast	0	PM-Stripe-10'_20'Skip /PM-Stripe-SKIP 10-10-20	2
X	tcdsrd	PMStripe(2-2-2)	Pavement Marking 2/2/2 Skip Traffic Stripe 6in Contrast	0	PM-Stripe-2'_2'Skip / PM-Stripe-SKIP 2-2-2	2
X	tcdsrd	PMStripe12B	Pavement Marking Traffic Stripe 12in Black	3	0 / Continuous	4
X	tcdsrd	PMStripe12W	Pavement Marking Traffic Stripe 12in White	0	0 / Continuous	4
X	tcdsrd	PMStripe12W(2-4)	Pavement Marking 2/4 Skip Traffic Stripe 12in White	0	0 / PM-Stripe-SKIP 2-4	4
X	tcdsrd	PMStripe12W(3-9)	Pavement Marking 3/9 Skip Traffic Stripe 12in White	0	0 / PM-Stripe-SKIP 3-9	4
X	tcdsrd	PMStripe12Y	Pavement Marking Traffic Stripe 12in Yellow	4	0 / Continuous	4
X	tcdsrd	PMStripe16B	Pavement Marking Traffic Stripe 16in Black	3	0 / Continuous	5
X	tcdsrd	PMStripe16W	Pavement Marking Traffic Stripe 16in White	0	0 / Continuous	5
X	tcdsrd	PMStripe16Y	Pavement Marking Traffic Stripe 16in Yellow	4	0 / Continuous	5
X	tcdsrd	PMStripe18B	Pavement Marking Traffic Stripe 18in Black	3	0 / Continuous	6
X	tcdsrd	PMStripe18W	Pavement Marking Traffic Stripe 18in White	0	0 / Continuous	6
X	tcdsrd	PMStripe18Y	Pavement Marking Traffic Stripe 18in Yellow	4	0 / Continuous	6
X	tcdsrd	PMStripe24W	Pavement Marking Traffic Stripe 24in White	0	0 / Continuous	7
X	tcdsrd	PMStripe24Y	Pavement Marking Traffic Stripe 24in Yellow	4	0 / Continuous	7
X	tcdsrd	PMStripe6B	Pavement Marking Traffic Stripe 6in Black	3	0 / Continuous	2
X	tcdsrd	PMStripe6B(10-30)	Pavement Marking 10/30 Skip Traffic Stripe 6in Black	3	0 / PM-Stripe-SKIP 10-30	2
X	tcdsrd	PMStripe6Bl	Pavement Marking Traffic Stripe 6in Blue	1	0 / Continuous	2
X	tcdsrd	PMStripe6DY	Pavement Marking Traffic Stripe 6in Double Yellow	4	0 / Continuous	2
X	tcdsrd	PMStripe6W	Pavement Marking Traffic Stripe 6in White	0	0 / Continuous	2
X	tcdsrd	PMStripe6W(10-30)	Pavement Marking 10/30 Skip Traffic Stripe 6in White	0	0 /PM-Stripe-SKIP 10-30	2
X	tcdsrd	PMStripe6W(2-4)	Pavement Marking 2/4 Skip Traffic Stripe 6in White	0	0 /PM-Stripe-SKIP 2-4	2
X	tcdsrd	PMStripe6W(3-9)	Pavement Marking 3/9 Skip Traffic Stripe 6in White	0	0 /PM-Stripe-SKIP 3-9	2
X	tcdsrd	PMStripe6W(6-10)	Pavement Marking 6/10 Skip Traffic Stripe 6in White	0	0 /PM-Stripe-SKIP 6-10	2
X	tcdsrd	PMStripe6Y	Pavement Marking Traffic Stripe 6in Yellow	4	0 / Continuous	2
X	tcdsrd	PMStripe6Y(10-30)	Pavement Marking 10/30 Skip Traffic Stripe 6in Yellow	4	0 /PM-Stripe-SKIP 10-30	2
X	tcdsrd	PMStripe6Y(2-4)	Pavement Marking 2/4 Skip Traffic Stripe 6in Yellow	4	0 /PM-Stripe-SKIP 2-4	2
X	tcdsrd	PMStripe6Y(6-10)	Pavement Marking 6/10 Skip Traffic Stripe 6in Yellow	4	0 /PM-Stripe-SKIP 6-10	2
X	tcdsrd	PMStripe8B	Pavement Marking Traffic Stripe 8in Black	3	0 / Continuous	3
X	tcdsrd	PMStripe8W	Pavement Marking Traffic Stripe 8in White	0	0 / Continuous	3
X	tcdsrd	PMStripe8W(3-9)	Pavement Marking 3/9 Skip Traffic Stripe 8in White	0	0 /PM-Stripe-SKIP 3-9	2
X	tcdsrd	PMStripe8Y	Pavement Marking Traffic Stripe 8in Yellow	4	0 / Continuous	3
X	tcdsrd	PMStripe9C(10-30)	Pavement Marking 10/30 Skip Traffic Stripe 9in Contrast	0	0 /PM-Stripe-SKIP 10-30	2
X	tcdsrd	PMStripeRumbleCL	Center Line Rumble Stripes (Use to Quantify Rumble Strips) (NonPlotting)	4	PM-Stripe-RumbleStripeLeft / PM-Stripe-RumbleStripe	2
X	tcdsrd	PMStripeRumbleWL	Rumble Stripes (6in White Thermoplastic Over Rumble Strips) (Left)	0	PM-Stripe-RumbleStripeLeft / PM-Stripe-RumbleStripe	2
X	tcdsrd	PMStripeRumbleWR	Rumble Stripes (6in White Thermoplastic Over Rumble Strips) (Right)	0	PM-Stripe-RumbleStripeRight / PM-Stripe-RumbleStripe	2
X	tcdsrd	PMStripeRumbleYL	Rumble Stripes (6in Yellow Thermoplastic Over Rumble Strips) (Left)	4	PM-Stripe-RumbleStripeLeft / PM-Stripe-RumbleStripe	2
X	tcdsrd	PMStripeRumbleYR	Rumble Stripes (6in Yellow Thermoplastic Over Rumble Strips) (Right)	4	PM-Stripe-RumbleStripeRight / PM-Stripe-RumbleStripe	2
X	tcdsrd	PMStripeVibeWL	Pavement Marking Auditory and Vibratory 6in White (Left)	0	PM-Stripe-VibratoryLeft /PM-Stripe-Vibratory	2
X	tcdsrd	PMStripeVibeWR	Pavement Marking Auditory and Vibratory 6in White (Right)	0	PM-Stripe-VibratoryRight /PM-Stripe-Vibratory	2
X	tcdsrd	PMStripeVibeYL	Pavement Marking Auditory and Vibratory 6in Yellow (Left)	4	PM-Stripe-VibratoryLeft /PM-Stripe-Vibratory	2
X	tcdsrd	PMStripeVibeYR	Pavement Marking Auditory and Vibratory 6in Yellow (Right)	4	PM-Stripe-VibratoryRight /PM-Stripe-Vibratory	2
	tcdsrd	PointLocator_ep	Point Locator Symbol (Existing)	4	0 / Continuous	0

Critical	Rule File	Level Name	Level Description	ByLevel Color	ByLevelStyle / Linetype	Bylevel Weight
X	tcdsrd	PoleElec	Electrical Pole w/ Transformer	3	0 / Continuous	2
X	tcdsrd	PoleShared	Power Pole Electric (Above Ground) Shared w/ Transformer	3	0 / Continuous	2
X	tcdsrd	PoleSteelStrain	Steel Strain Pole	0	0 / Continuous	2
X	tcdsrd	PoleSteelStrain_ep	Steel Strain Pole (Existing)	0	2 / DGN2	1
X	tcdsrd	PoleTel	Telephone Pole	6	0 / Continuous	2
X	tcdsrd	PoleUtil	Utility Pole	0	0 / Continuous	2
X	tcdsrd	PoleWoodStrain	Wood Strain Pole	0	0 / Continuous	2
X	tcdsrd	PoleWoodStrain_ep	Wood Strain Pole (Existing)	0	2 / DGN2	1
X	tcdsrd	PropertyLine_ep	Property Lines (Existing)	3	0 / Continuous	0
	tcdsrd	RailroadMisc_ep	Railroad Switch, Warning Sign, Milepost (Existing)	11	0 / Continuous	0
	tcdsrd	ReferencePt_dp	Survey and Construction Reference Point Details and Elements	4	0 / Continuous	2
X	tcdsrd	RockGravelStone	Rock, Gravel, Stone, Boulders, Etc.	1	0 / Continuous	2
X	tcdsrd	RPM_ep	Reflective Pavement Markers (Existing)	2	2 / DGN2	1
X	tcdsrd	RPM1	Raised Pavement Markers, White	0	0 / Continuous	2
X	tcdsrd	RPM2	Raised Pavement Markers, White - Red	3	0 / Continuous	2
X	tcdsrd	RPM3	Raised Pavement Markers, Yellow	4	0 / Continuous	2
X	tcdsrd	RPM4	Raised Pavement Markers, Yellow - Yellow	9	0 / Continuous	2
X	tcdsrd	RPM5	Raised Pavement Markers, Yellow - Red	6	0 / Continuous	2
X	tcdsrd	RPM6	Raised Pavement Markers, Blue	1	0 / Continuous	2
X	tcdsrd	RWLLine	Right of Way Lines	4	RW-Proposed	2
X	tcdsrd	RWLLine_ep	Right of Way Lines (Existing)	3	RW-Existing	1
	tcdsrd	Scale_dp	Bar Scale, Scale Label Elements	0	0 / Continuous	2
	tcdsrd	Scratch1_dp	Scratch Level for Temporary or Informational Items	4	0 / Continuous	0
	tcdsrd	Scratch2_dp	Scratch Level for Temporary or Informational Items	5	0 / Continuous	0
	tcdsrd	ScratchEle_dp	Scratch Level for Draft Elements, Temporary Elements, Etc. (DO NOT PLOT)	3	0 / Continuous	0
	tcdsrd	ScratchEle2_dp	Scratch Level for Draft Elements, Temporary Elements, Etc. (DO NOT PLOT)	4	0 / Continuous	0
101	tcdsrd	SedimentBarrier	Synthetic Bales and Staked Silt Fences	10	SWP-HayBales	2
101	tcdsrd	SedimentBarrier	Synthetic Bales and Staked Silt Fences	10	SWP-SiltFence	2
	tcdsrd	SheetBorder_dp	Sheet Border	1	0 / Continuous	4
	tcdsrd	SheetLines_dp	Sheet Lines	1	0 / Continuous	2
	tcdsrd	SheetLinesMisc1_dp	Sheet Lines	1	0 / Continuous	0
	tcdsrd	SheetLinesMisc2_dp	Sheet Lines	2	0 / Continuous	2
	tcdsrd	SheetLinesMisc3_dp	Sheet Lines	3	0 / Continuous	2
	tcdsrd	SheetLinesMisc4_dp	Sheet Lines	4	0 / Continuous	2
	tcdsrd	ShldrHatch	Shoulder Hatch Pattern	1	0 / RD-PavedShldr6	1
X	tcdsrd	ShldrPaved	Shoulder Line (Paved)	1	0 / Continuous	1
	tcdsrd	ShldrPaved_ep	Shoulder Edge (Paved) (Existing)	1	3 / DGN3	0
X	tcdsrd	SidewalkConc	Sidewalk Concrete Shape	0	0 / Continuous	2
X	tcdsrd	SignalCable	Signal Cable	3	SG-Cable / Continuous	1
X	tcdsrd	SignalCableAccs	Signal Cable Accessories	0	0 / Continuous	2
X	tcdsrd	SignalDetail	Signal Details	0	0 / Continuous	1
	tcdsrd	SignalHead	Signal Head Section Details	2	0 / Continuous	1
X	tcdsrd	SignalHead_ep	Signal Head Section Details (Existing)	2	2 / DGN2	0
	tcdsrd	SignalMisc	Signal Equipment (Miscellaneous)	3	0 / Continuous	1
X	tcdsrd	SignalSOP	S.O.P. Box and Movements	0	0 / Continuous	2
X	tcdsrd	SignalSym	Signal Head Symbols	0	0 / Continuous	1



Critical	Rule File	Level Name	Level Description	ByLevel Color	ByLevelStyle / Linetype	Bylevel Weight
X	tcdsrd	SignalSym_ep	Signal Head Symbols (Existing)	3	2 / DGN2	0
X	tcdsrd	SignalWorkZone	Traffic Signal / Portable Signal	3	0 / Continuous	2
X	tcdsrd	SignCantilever	Sign Symbol Cantilever	0	0 / Continuous	1
X	tcdsrd	SignCantilever_ep	Sign Symbol Cantilever (Existing)	0	2 / DGN2	0
	tcdsrd	SignDetail	Sign Details	0	0 / Continuous	2
	tcdsrd	SignLettersAZ	Alphabet Cell Library Letter A-Z Numbers 0-9	0	0 / Continuous	0
	tcdsrd	SignMisc	Sign Symbols (Miscellaneous)	3	0 / Continuous	1
	tcdsrd	SignMisc_ep	Sign Symbols (Miscellaneous) (Existing)	1	1 / DGN1	1
X	tcdsrd	SignPanel	Sign Panels - Regulatory	0	0 / Continuous	2
X	tcdsrd	SignPanel_ep	Sign Panel Elements (Existing)	0	2 / DGN2	1
X	tcdsrd	SignPanelBorder	Sign Panel Border on Sign Details	0	0 / Continuous	1
X	tcdsrd	SignPanelC	Sign Panels - Civil	1	0 / Continuous	2
X	tcdsrd	SignPanelDetRed	Sign Panel Details in Red	3	0 / Continuous	2
X	tcdsrd	SignPanelG	Sign Panels - Guide	2	0 / Continuous	2
X	tcdsrd	SignPanelI	Sign Panels - Special Interest	9	0 / Continuous	2
X	tcdsrd	SignPanelT	Sign Panels - Construction	6	0 / Continuous	2
X	tcdsrd	SignPanelW	Sign Panels - Warning	4	0 / Continuous	2
X	tcdsrd	SignSpanwire	Span Wire Signing Assembly	2	0 / Continuous	1
X	tcdsrd	SignSpanwire_ep	Span Wire Signing Assembly (Existing)	2	2 / DGN2	1
X	tcdsrd	SignSpecial	Special Signs / Guide Signs	2	0 / Continuous	2
X	tcdsrd	SignSupport	Ground Mounted Sign Support Symbol (All Types)	1	0 / Continuous	1
X	tcdsrd	SignSymbol_px	Sign Structure and Foundation on Cross Sections	4	0 / Continuous	2
X	tcdsrd	SignTruss	Sign Symbol Truss	3	0 / Continuous	1
X	tcdsrd	SignTruss_ep	Sign Symbol Truss (Existing)	3	2 / DGN2	1
X	tcdsrd	SignWorkZone	Work Zone Signs	6	0 / Continuous	2
X	tcdsrd	Sod	Performance Sod	2	0 / Continuous	2
	tcdsrd	SpecialDetails	Special Details	6	0 / Continuous	1
	tcdsrd	StationTicL_dp	Station Tic Marks (Large) and Text	0	0 / Continuous	2
	tcdsrd	StationTicS_dp	Station Tic Marks (Small) and Text	0	0 / Continuous	2
	tcdsrd	Structure	Structures	0	0 / Continuous	2
	tcdsrd	SumBoxBorder_dp	Summary Boxes Borders	4	0 / Continuous	3
	tcdsrd	SumBoxLines_dp	Summary Boxes Lines and Miscellaneous Items	4	0 / Continuous	1
	tcdsrd	SumBoxLinesMin_dp	Summary Boxes Lines Minor Line and Miscellaneous Items	4	0 / Continuous	0
	tcdsrd	Tables_dp	Data Tables and All Autodesk Tables	0	0 / Continuous	1
	tcdsrd	TextBLStation	Text - B/L Station and Tics	0	0 / Continuous	2
	tcdsrd	TextConstEle	Text - Construction Element	0	0 / Continuous	1
	tcdsrd	TextCurveData	Text - Curve Data Note	0	0 / Continuous	2
	tcdsrd	TextDetails	Text - Detail Notes	4	0 / Continuous	2
	tcdsrd	TextDrainInvElev_ep	Text - Drainage Invert Elevation (Existing)	0	0 / Continuous	1
	tcdsrd	TextDrainLabel_ep	Text - Drainage (Existing)	0	0 / Continuous	1
	tcdsrd	TextElevLabel	Text - Elevation Labels	4	0 / Continuous	0
	tcdsrd	TextLabel	Text - Label	0	0 / Continuous	2
	tcdsrd	TextLandscape	Text - Landscape Labels	0	0 / Continuous	1
	tcdsrd	TextMajor	Text - Major	0	0 / Continuous	5
	tcdsrd	TextMinor	Text - Minor	0	0 / Continuous	0
	tcdsrd	TextMisc	Text - Miscellaneous	0	0 / Continuous	1

Critical	Rule File	Level Name	Level Description	ByLevel Color	ByLevelStyle / Linetype	ByLevel Weight
	tcdsrd	TextNotes	Text - Notes	4	0 / Continuous	1
	tcdsrd	TextProfLabel	Text - Profile, Horizontal and Vertical Axis Labels	0	0 / Continuous	2
	tcdsrd	TextProjLabel	Text - Begin and End Project Label with Leader Lines	1	0 / Continuous	2
	tcdsrd	TextPtLabel	Text - Point Labels	4	0 / Continuous	0
	tcdsrd	TextShtNo	Text - Sheet Number	0	0 / Continuous	2
	tcdsrd	TextSubUtilLabel_ep	Text - Subsurface Utilities (Existing)	0	0 / Continuous	1
	tcdsrd	TextSurveyLabel	Text - Survey Labels	0	0 / Continuous	0
	tcdsrd	TextTables	Text - Key Sheet Indexes and Table Data	4	0 / Continuous	2
	tcdsrd	TextTitle	Text - Title	0	0 / Continuous	3
	tcdsrd	TextTopoLabel_ep	Text - Topography (Existing)	0	0 / Continuous	1
	tcdsrd	TextUtilLabel_ep	Text - Utilities (Existing)	0	0 / Continuous	1
	tcdsrd	TextXSElev	Text - Cross Section Elevations	2	0 / Continuous	1
X	tcdsrd	TrafficControlMisc	Traffic Control Items (Miscellaneous)	3	0 / Continuous	1
X	tcdsrd	TrafSeparator	Traffic Separator (All Types)	6	0 / Continuous	1
X	tcdsrd	TrafSeparator_px	Traffic Separator on Cross Sections (All Types)	6	0 / Continuous	2
X	tcdsrd	TubularMarker_px	Tubular Markers on Typical	6	0 / Continuous	2
X	tcdsrd	TurbidityBarrier1	Turbidity Barrier 1 (Floating)	10	SWP-TurbidityBarrier-Type1	2
	tcdsrd	TurbidityBarrier1_ep	Turbidity Barrier 1 (Floating) (Existing)	10	1 / DGN1	2
X	tcdsrd	TurbidityBarrier2	Turbidity Barrier 2 (Staked)	10	SWP-TurbidityBarrier-Type2	2
	tcdsrd	TurbidityBarrier2_ep	Turbidity Barrier 2 (Staked) (Existing)	10	1 / DGN1	2
X	tcdsrd	Turf	Performance Turf	100	0 / Continuous	2
	tcdsrd	TypicalMisc	Typical Items (Miscellaneous)	0	0 / Continuous	2
	tcdsrd	Viewport	Viewport (For AutoCAD Use)	3	0 / Continuous	0
X	tcdsrd	WallBarrier	Barrier Wall (All Types)	6	0 / Continuous	2
X	tcdsrd	WallTempBarrier	Barrier Wall (Temporary)	6	0 / Continuous	2
X	tcdsrd	WallTempBarrier_px	Barrier Wall (Temporary) on Typical	6	0 / Continuous	2
	tcdsrd	Xreference01_dp	Reference Files (For AutoCAD Use)	0	0 / Continuous	1
	tcdsrd	Xreference02_dp	Reference Files (For AutoCAD Use)	0	0 / Continuous	1
	tcdsrd	Xreference03_dp	Reference Files (For AutoCAD Use)	0	0 / Continuous	1
	tcdsrd	Xreference04_dp	Reference Files (For AutoCAD Use)	0	0 / Continuous	1
	tcdsrd	XSCell	GEOPAK Cross Section Cell/Block and Profile Cell/Block	8	0 / Continuous	1
X	tcdsrd	XSTypical_px	Cross Sections Roadway Pavement Typical	1	0 / Continuous	2

## TOPORD - Existing Topography for Roadway

Critical	Rule File	Level Name	Level Description	ByLevel Color	ByLevel Style	ByLevel Weight	Point /Line	Feature Code
	topord	ArchSite_ep	Archeological Site (Existing)	2	0 / Continuous	1	L	ARST
	topord	Attenuator_ep	Attenuator Systems (Existing)	0	0 / Continuous	1	L	ATTN
	topord	BankMent_ep	Embankment (Manmade, Top or Bottom) (Existing)	9	3 / DGN3	0	L	BNK
	topord	Beacons_ep	Beacons and Path Illumination (Existing)	0	0 / Continuous	1	P	BN
	topord	Bollard_ep	Bollards (Existing)	0	2 / DGN2	1	P	BOL
	topord	Bridge_ep	Bridge Approaches and Slabs (Existing)	0	3 / DGN3	1	L	APRS
	topord	BridgeEle_ep	Bridge Elements (Existing)	0	1 / DGN1	0	L	BRDG
X	topord	Building_ep	Buildings (Existing)	1	0 / Continuous	0	L	BLDG
	topord	BusStop_ep	Bench, Bus Stop (Existing)	8	1 / DGN1	0	P	BNCH
	topord	CableBarrier_ep	Cable Barrier (Existing)	0	RD-CableBarrier	1	L	CBR
	topord	Canal_ep	Canal, Lock (Existing)	7	3 / DGN3	0	L	CAN
	topord	CattleGuard_ep	Cattle Guard (Existing)	7	1 / DGN1	0	P	CGD
	topord	CGBack_ep	Curb and Gutter (Back) (Existing)	4	3 / DGN3	0	L	CGB
	topord	CGep_ep	Curb / Curb and Gutter (at EP & FL) (Existing)	0	3 / DGN3	0	L	CG
	topord	CGFace_ep	Face of Curb and Gutter (Existing)	4	3 / DGN3	0	L	CGF
	topord	ConcSlabs_ep	Concrete Slabs (Existing)	0	1 / DGN1	1	L	CSL
	topord	ConstLines	Construction Lines and Preferences	1	0 / Continuous	0		
	topord	ConstLines_pm	Construction Lines	4	0 / Continuous	0		
	topord	Core_ep	Core Sample or Test Hole (Existing)	9	0 / Continuous	0	P	CSH
	topord	CurbRamp_ep	Curb Cut Ramp (Existing)	2	3 / DGN3	0	L	CCR
	topord	CurbRampWarning_ep	Detectable Warnings on Curb Ramps (Existing)	4	3 / DGN3	0	L	CRW
	topord	Deck_ep	Deck / Porch (Existing)	7	1 / DGN1	0	L	DECK
	topord	DelineatorPost_ep	Delineator Post, Existing Metal and Flexible (Existing)	4	1 / DGN1	1	P	DLP
	topord	Ditch_ep	Ditch (Top, Bottom and Flow Lines) (Existing)	7	6 / DGN6	0	L	DTCH
	topord	DitchPavt_ep	Ditch Pavement (Existing)	0	1 / DGN1	0	L	DTCHP
	topord	Docks_ep	Docks and Wharfs (Existing)	0	1 / DGN1	0	L	DOCK
	topord	Dolphins_ep	Dolphins and Fenders (Existing)	7	1 / DGN1	0	P	DF
	topord	Driveway_ep	Driveway (Drive, Lane, Turnouts) (Existing)	7	3 / DGN3	0	L	DWY
	topord	DummyChains_ep	Dummy Chains (Existing)	0	0 / Continuous	1	L	DUMB
	topord	Fence_ep	Fence (All) (Existing)	6	RD-Fence	0	L	FNC
	topord	FloodLight_ep	Flood Light (Existing)	3	1 / DGN1	1	P	FLD
	topord	Furnace_ep	Incinerator, Boiler, or Furnace (Existing)	8	1 / DGN1	0	P	INCN
	topord	Gates_ep	Gates (Existing)	7	3 / DGN3	0	L	GT
	topord	GlareScrn_ep	Glare Screen & Blinds (Existing)	0	{ curtain } / RD-Curtain	0	L	GS
	topord	GuardrailDbl_ep	Guardrail Double Face (Existing)	0	RD-Guardrail-Double	0	L	GRDBL
	topord	GuardrailLt_ep	Guardrail Left (Existing)	0	RD-Guardrail-Left	0	L	GRL
	topord	GuardrailRt_ep	Guardrail Right (Existing)	0	RD-Guardrail-Right	0	L	GRR
	topord	Hole_ep	Hole (Existing)	8	1 / DGN1	0	P	HOLE
	topord	ImageAttachment_dp	Image Attachments	0	0 / Continuous	0		
	topord	LaneLine_ep	Lane Lines (Existing)	0	RD-LaneLine-Existing	1	L	LL
	topord	LeaderLine_dp	Leader Line and Terminator with Text	0	0 / Continuous	1		
	topord	Mailbox_ep	Mailbox(s) (Existing)	8	1 / DGN1	0	P	MBX
	topord	MiscEquip_ep	Flag Pole (Existing)	8	1 / DGN1	0	P	FP
	topord	MiscEquip_ep	Parking Meter (Existing)	8	1 / DGN1	0	P	PKGM
	topord	Monument_ep	Aerial Targets (Existing)	4	0 / Continuous	0	P	AT
	topord	Monument_ep	Concrete Monument (Cast) (Existing)	4	0 / Continuous	0	P	CMON

Critical	Rule File	Level Name	Level Description	ByLevel Color	ByLevel Style	Bylevel Weight	Point /Line	Feature Code
	topord	Monument_ep	Drill Hole, Plug (Control Monumentation) (Existing)	4	0 / Continuous	0	P	DH
	topord	Monument_ep	Deep Rod Mark (Existing)	4	0 / Continuous	0	P	DRM
	topord	Monument_ep	5/8 Rod and Cap (Existing)	4	0 / Continuous	0	P	IRC
	topord	Monument_ep	Nail, Spike, Pin (Control Monumentation) (Existing)	4	0 / Continuous	0	P	NL
	topord	Monument_ep	Other Marker? (Control Monumentation) (Existing)	4	0 / Continuous	0	P	OM
	topord	Monument_ep	Metal Pipe, Rod, Bar (Control) (Existing)	4	0 / Continuous	0	P	PIP
	topord	Monument_ep	Concrete Monument (Poured) (Existing)	4	0 / Continuous	0	P	PMON
	topord	Monument_ep	Post, Stake, Staub (Control Monumentation) (Existing)	4	0 / Continuous	0	P	PST
	topord	Monument_ep	Hub and Tac (Existing)	4	0 / Continuous	0	P	SAT
	topord	Monument_ep	Stamped Disk (Existing)	4	0 / Continuous	0	P	STMD
	topord	Monument_ep	Stamped Plate (Existing)	4	0 / Continuous	0	P	STMP
	topord	ParkEquip_ep	Campstove, Grill, Firepit, BBQ (Existing)	9	2 / DGN2	0	P	CMPST
	topord	ParkEquip_ep	Playground Equipment (Existing)	9	2 / DGN2	0	P	PLEQ
	topord	Patternlines_ep	Cross Section Chain (Existing)	2	1 / DGN1	0	L	XSC
	topord	Pavemk_ep	Handicap Pavement Marking (Existing)	0	2 / DGN2	0	P	HNDG
	topord	Pavemk_ep	Pavement Markings (Other) (Existing)	0	2 / DGN2	0	L	PMRK
	topord	Pavemk_ep	Straight Direction Arrow (Existing)	0	2 / DGN2	0	P	STAROW
	topord	Pavemk_ep	Straight and Turn Arrow (Existing)	0	2 / DGN2	0	P	STATRN
	topord	Pavemk_ep	Turn Arrow (Existing)	0	2 / DGN2	0	P	TA
	topord	PavtAsphalt_ep	Asphalt Pavement Edge (Existing)	0	3 / DGN3	1	L	AP
	topord	PavtConcrete_ep	Concrete Pavement (Edges) (Existing)	0	3 / DGN3	1	L	CPVT
	topord	PavtConcJoints_ep	Concrete Pavement (Joints) (Existing)	1	5 / DGN5	1	L	CPVJ
	topord	PavtCrown_ep	Asphalt Pavement (Crown) (Existing)	0	4 / DGN4	1	L	AC
	topord	PavtCrown_ep	Concrete Pavement (Crown) (Existing)	0	4 / DGN4	1	L	CPVC
	topord	PavtMisc_ep	Pavement Parking Lot/Guardrail/Misc Pavement (Existing)	7	3 / DGN3	0	L	MP
	topord	PavtTractorXing_ep	Tractor Crossings (Existing)	0	3 / DGN3	1	L	TX
	topord	PavtXover_ep	Crossovers and Detours (Temporary) (Existing)	0	3 / DGN3	0	L	XO
	topord	PedSignal_ep	Pedestrian Signal Unit, Signage (Existing)	0	2 / DGN2	0	P	PS
	topord	Piling_ep	Piling, Piers, or Column (Existing)	8	3 / DGN3	0	P	PIL
	topord	Pumpsland_ep	Pump Island (Existing)	7	3 / DGN3	1	L	PMPIS
	topord	Railing_ep	Railings (All); Piperail, Guiderail, Handrail used for Pedestrian and Bicycles (Existing)	9	3 / DGN3	0	L	HNDRL
	topord	RailroadMisc_ep	Railroad Milepost (Existing)	11	0 / Continuous	0	P	RRMP
	topord	RailroadMisc_ep	Railroad Switch (Existing)	11	0 / Continuous	0	P	RRS
	topord	RailroadMisc_ep	Railroad Warning Sign (Existing)	11	0 / Continuous	0	P	RRWS
	topord	RailroadMisc_ep	Railroad Signal with Gate (Existing)	11	0 / Continuous	0	P	SWG
	topord	RailroadTracks_ep	Railroad Tracks (Rail, Bed) (Existing)	4	3 / DGN3	0	L	RR
	topord	RailroadXing_ep	Railroad Crossing (Roadway Platforms), Railroad Signal w/ Gate (Existing)	11	3 / DGN3	0	L	RRX
X	topord	RefPtLine	Survey Reference Point Line / Detail (Miscellaneous)	0	0 / Continuous	1		
X	topord	RefPtText	Annotation: Text: Survey Data Reference Point (Miscellaneous)	0	0 / Continuous	1		
	topord	RipRap_ep	Rip Rap, Rubble (Existing)	4	3 / DGN3	1	L	RIP
X	topord	RRBaseline	Baseline: Rail Road Centerline	4	0 / Continuous	2	L	RRCL
	topord	Scratch1_dp	Scratch Level for Temporary or Informational Items	4	0 / Continuous	0		
	topord	Scratch2_dp	Scratch Level for Temporary or Informational Items	5	0 / Continuous	0		
	topord	ShldrPaved_ep	Shoulder Edge (Paved) (Existing)	1	3 / DGN3	0	L	SHLDR
	topord	ShldrUnpaved_ep	Shoulders (Unpaved) (Existing)	0	3 / DGN3	0	L	UNPS
	topord	Shrub_ep	Hedges and Shrubs (Boundary) (Existing)	2	0 / Continuous	0	L	HED
	topord	Shrub_ep	Ornamental Plant (Existing)	2	0 / Continuous	0	P	OP
	topord	Shrub_ep	Shrub, Bush (Existing)	2	0 / Continuous	0	P	SHR

Critical	Rule File	Level Name	Level Description	ByLevel Color	ByLevel Style	Bylevel Weight	Point /Line	Feature Code
	topord	Shrub_ep	Coniferous Shrub (Existing)	2	0 / Continuous	0	P	SHRC
	topord	Shrub_ep	Deciduous Shrub (Existing)	2	0 / Continuous	0	P	SHRD
	topord	SidewalkBack_ep	Back of Sidewalk (Existing)	2	3 / DGN3	0	L	SWKB
	topord	SidewalkFront_ep	Front of Sidewalk (Existing)	1	3 / DGN3	0	L	SWK
	topord	Signal_ep	Signal Head (Existing)	3	1 / DGN1	1	P	SIG
	topord	Signal_ep	Signal on Pedestal (Existing)	3	1 / DGN1	1	P	SIGP
	topord	SignalLoop_ep	Traffic Detector Loops (Existing)	7	1 / DGN1	2	L	TFD
	topord	SignalMisc_ep	Signal Equipment Including Control Unit (Miscellaneous) (Existing)	3	2 / DGN2	0	P	SIGC
	topord	SignalSupport_ep	Signal Supports Including Mast Arm (Existing)	3	2 / DGN2	0	P	SMA
	topord	SignalSupport_ep	Support Mast Arm Extention (Existing)	3	2 / DGN2	0	L	SMAE
	topord	SignMulti_ep	Multi-column Sign (Large Sign) (Existing)	0	3 / DGN3	1	L	MS
	topord	SignSingle_ep	Sign (Single Support) (Existing)	3	2 / DGN2	0	P	SSS
	topord	SignSupport_ep	Trusses and Cantilevers for Overhead Signs (Existing)	0	3 / DGN3	1	L	SGNT
	topord	Silo_ep	Silo (Existing)	11	2 / DGN2	0	P	SILO
	topord	Slopes_ep	Levees, Dikes, or Dams (Top or Bottom) (Existing)	9	3 / DGN3	0	L	LV
	topord	Slopes_ep	Natural Slopes (Top or Bottom) (Existing)	9	3 / DGN3	0	L	SLP
	topord	SpanWire_ep	Signal / Span Wire Pole (Existing)	3	2 / DGN2	0	P	SSP
	topord	SpanWire_ep	Signal / Span Wire Pole (Existing)	3	2 / DGN2	0	L	SSW
	topord	Stairs_ep	Stairways, Steps (Existing)	0	3 / DGN3	1	L	STP
	topord	Stream_ep	Stream Edge (Existing)	1	3 / DGN3	0	L	STRM
	topord	Stream_ep	Stream Center (Existing)	1	3 / DGN3	0	L	STRMC
	topord	StreamMisc_ep	Buoy (Existing)	7	0 / Continuous	0	P	BUOY
	topord	StreamMisc_ep	Stream or Tide Gauge (Existing)	7	0 / Continuous	0	P	TG
	topord	Stump_ep	Stump (Existing)	2	0 / Continuous	0	P	STM
	topord	Tables_dp	Data Tables and All Autodesk Tables	0	0 / Continuous	1		
	topord	TankStor_ep	Storage Tank (Existing)	11	3 / DGN3	0	P	STTK
	topord	TankUG_ep	Fill Cap (Buried Tank) (Existing)	3	1 / DGN1	0	P	FC
	topord	TextCurveData	Text - Curve Data Note	0	0 / Continuous	2		
	topord	TextLabel	Text - Label	0	0 / Continuous	2		
	topord	TextMisc	Text - Miscellaneous	0	0 / Continuous	1		
	topord	TextNotes	Text - Notes	4	0 / Continuous	1		
	topord	TextTopoLabel_ep	Text - Topography (Existing)	0	0 / Continuous	1		
	topord	TopoMisc_ep	Topography (Miscellaneous) (Existing)	0	3 / DGN3	1	L	MISC
	topord	TrafSeparator_ep	Traffic Separator (Existing)	6	3 / DGN3	0	L	TFSP
	topord	Trail_ep	Roadway, Trail (Unpaved) (Existing)	9	3 / DGN3	1	L	RD
	topord	Trash_ep	Dumpster, Trash Disposal (Existing)	9	0 / Continuous	0	P	DMP
	topord	Treadle_ep	Treadle (Existing)	7	1 / DGN1	5	L	TRD
	topord	Tree_ep	Tree (Existing)	2	0 / Continuous	0	P	TREE
	topord	Tree_ep	Coniferous Tree (Existing)	2	0 / Continuous	0	P	TREEC
	topord	Tree_ep	Citrus Tree (Existing)	2	0 / Continuous	0	P	TREECI
	topord	Tree_ep	Cypress Tree (Existing)	2	0 / Continuous	0	P	TREECY
	topord	Tree_ep	Deciduous Tree (Existing)	2	0 / Continuous	0	P	TREED
	topord	Tree_ep	Oak Tree (Existing)	2	0 / Continuous	0	P	TREEOA
	topord	Tree_ep	Palm Tree (Existing)	2	0 / Continuous	0	P	TREEPA
	topord	Tree_ep	Palm Tree Cluster (Existing)	2	0 / Continuous	0	P	TREEPC
	topord	Tree_ep	Pine Tree (Existing)	2	0 / Continuous	0	P	TREEPI
	topord	TreeLine_ep	Groves & Orchards (Boundary) (Existing)	2	RD-TreeLine	0	L	GRV
	topord	TreeLine_ep	Scattered Trees (Boundary) (Existing)	2	RD-TreeLine	0	L	SCT

Critical	Rule File	Level Name	Level Description	ByLevel Color	ByLevel Style	ByLevel Weight	Point /Line	Feature Code
	topord	TreeLine_ep	Woods Line (Existing)	2	RD-TreeLine	0	L	WDL
	topord	Tributary_ep	Spring (Water Source) (Existing)	1	0 / Continuous	0	P	SPR
	topord	Viewport	Viewport (For AutoCAD Use)	3	0 / Continuous	0		
	topord	Wall_ep	Walls (Existing)	9	3 / DGN3	1	L	WALL
	topord	WallBarrier_ep	Wall Dividing Traffic (All) (Existing)	6	3 / DGN3	0	L	BARW
	topord	WallBarrier_ep	Wall Dividing Traffic (All) (Existing) (Temporary)	6	3 / DGN3	0	L	TMPW
	topord	WallRetainEarth_ep	Wall Holding Earth (All) (Existing)	6	3 / DGN3	0	L	RETW
	topord	WallSea_ep	Sea Walls (Existing)	0	1 / DGN1	3	L	SEAW
	topord	WaterEdge_ep	Edge of Water (Existing)	7	3 / DGN3	0	L	WEDG
	topord	Wetland_ep	W.M.D. & D.E.P. Wetlands (Existing)	1	RD-Wetland-Existing	0	L	DEP
	topord	WetlandEdge_ep	CORPS Wetlands (Marsh or Swamp) (Existing)	2	RD-Wetland-Existing	0	L	COE
	topord	WetlandEdge_ep	Edge of Mangrove (Existing)	2	RD-Wetland-Existing	0	L	EM
	topord	WetlandEdge_ep	Edge of Wetlands (Marsh or Swamp) (Existing)	2	RD-Wetland-Existing	0	L	MAR
	topord	WetlandSym_ep	Marsh Symbol (Existing)	2	1 / DGN1	0	P	MAR
	topord	WetlandSym_ep	Wetland Point (Existing)	2	1 / DGN1	0	P	WLPT
	topord	WindMill_ep	Wind Mill (Existing)	1	1 / DGN1	0	P	WIM
	topord	Xreference01_dp	Reference Files (For AutoCAD Use)	0	0 / Continuous	1		
	topord	Xreference02_dp	Reference Files (For AutoCAD Use)	0	0 / Continuous	1		
	topord	Xreference03_dp	Reference Files (For AutoCAD Use)	0	0 / Continuous	1		
	topord	Xreference04_dp	Reference Files (For AutoCAD Use)	0	0 / Continuous	1		
	topord	XSPT_ep	Cross Section Point, Station (Existing)	2	1 / DGN1	0	P	XS

## TYPDRD - Typical Section Data

Critical	Rule File	Level Name	Level Description	ByLevel Color	ByLevelStyle / Linetype	ByLevel Weight
	typdrd	ActivePointCell_dp	Active Point Cell	4	0 / Continuous	10
	typdrd	AdhocPoint_dp	Adhoc Points Placed by SheetInfo	0	4 / DGN4	0
X	typdrd	AdvWarnPanel	Advance Warning Arrow Panels	4	0 / Continuous	2
X	typdrd	AdvWarnVehicle	Work/Shadow/Advanced Warning Vehicle	3	0 / Continuous	2
X	typdrd	Attenuator	Attenuator Systems	6	MOT-Attenuator	1
X	typdrd	AttenuatorTM	Attenuator Truck Mount	6	0 / Continuous	2
X	typdrd	Barricade_px	Barricades Type I and II, Vertical Panels on Typical	6	0 / Continuous	2
X	typdrd	BarricadeIII	Barricade Type III	6	0 / Continuous	2
X	typdrd	BarricadeIII_px	Barricade Type III on Typical	6	0 / Continuous	2
	typdrd	BaselineSurvey	Baseline Survey	0	0 / Continuous	2
X	typdrd	Berm_px	Berm (Top, Front, or Back) on Cross Sections	10	0 / Continuous	2
X	typdrd	BoxCulvert	Box Culvert	10	0 / Continuous	2
X	typdrd	Bridge_px	Bridge Component on Cross Sections - Component Property	0	0 / Continuous	2
X	typdrd	CandG_ex	Curb and Gutter on Cross Sections (All Types) (Existing)	4	2 / DGN2	1
X	typdrd	CandG_px	Curb and Gutter on Cross Sections (All Types)	4	0 / Continuous	2
X	typdrd	CandGBase_px	Curb and Gutter Base on Cross Sections	3	0 / Continuous	1
X	typdrd	ChannelDev	Channelizing Devices	0	0 / Continuous	2
X	typdrd	ChannelDevPed_px	Longitudinal Channelizing Device for Pedestrians on Typical	6	0 / Continuous	2
	typdrd	CLConst_dp	Center Line of Construction	0	0 / Continuous	2
	typdrd	Cloud_dp	Construction Cloud	7	0 / Continuous	2
	typdrd	COGO_dp	COGO Information	3	0 / Continuous	1



Critical	Rule File	Level Name	Level Description	ByLevel Color	ByLevelStyle / Linetype	ByLevel Weight
X	typdrd	Concrete	Concrete Areas and Miscellantous (All Types)	0	0 / Continuous	2
X	typdrd	ConcSlabs	Concrete Slabs	0	0 / Continuous	2
X	typdrd	Conduit_px	Conduit and Encasements on Cross Sections	3	0 / Continuous	1
X	typdrd	Cone_px	Cone and Tubular Marker on Typicals	6	0 / Continuous	2
	typdrd	ConstArea_dp	Construction Area Crosshatch	0	0 / Continuous	1
	typdrd	ConstLimits	Construction Limits	3	RW-LimitsofConst	2
	typdrd	ConstLines	Construction Lines and References	1	0 / Continuous	0
	typdrd	ConstLines_pm	Construction Lines	4	0 / Continuous	0
X	typdrd	CurbBack	Back of Curb	4	0 / Continuous	1
X	typdrd	CurbFace	Curb and Gutter (Face)	4	0 / Continuous	1
X	typdrd	CurbRamp	Curb Cut Ramp	8	0 / Continuous	1
	typdrd	CurveData_dp	Curve and Coordinate Data Elements Including PC, PT, PI Symbols	4	0 / Continuous	2
	typdrd	CurveDataLabel_dp	Curve Data Labels PC,PI, PT	0	0 / Continuous	2
	typdrd	DimLines_dp	Dimension Lines, Corresponding Terminators, Equation Lines	0	0 / Continuous	1
X	typdrd	DirArrowsPavt	Pavement Marking Directional Arrows	0	0 / Continuous	1
X	typdrd	Ditch	Ditch Top	7	6 / DGN6	1
X	typdrd	Ditch_px	Ditch Top on Cross Sections	7	0 / Continuous	2
X	typdrd	DitchBot	Ditch Bottom	10	0 / Continuous	2
X	typdrd	DitchBot_px	Ditch Bottom on Cross Sections	10	0 / Continuous	2
X	typdrd	DitchPavt	Ditch Pavement Including Quantity Shapes	3	0 / Continuous	1
X	typdrd	DitchPavt_px	Ditch Pavement on Cross Sections	3	0 / Continuous	3
	typdrd	DitchProfLt_er	Ditch Profile Left (Existing)	8	3 / DGN3	1
	typdrd	DitchProfLt_pr	Ditch Profile Left	8	0 / Continuous	1
	typdrd	DitchProfMdn_er	Ditch Profile Median (Existing)	10	3 / DGN3	1
	typdrd	DitchProfMdn_pr	Ditch Profile Median	10	0 / Continuous	1
	typdrd	DitchProfRt_er	Ditch Profile Right (Existing)	9	3 / DGN3	1
	typdrd	DitchProfRt_pr	Ditch Profile Right	9	0 / Continuous	1
X	typdrd	DrainStruct_pr	Drainage Structures (All Types)	10	0 / Continuous	2
X	typdrd	DrainStruct_px	Drainage Structures and Elements on Cross Sections (Miscellaneous)	10	0 / Continuous	2
X	typdrd	Driveway_px	Driveway Lines on Cross Sections	7	0 / Continuous	2
X	typdrd	DrivewayBase_px	Driveway Subgrade on Cross Sections	3	0 / Continuous	2
X	typdrd	Drum_px	Drum on Typicals	6	0 / Continuous	2
	typdrd	Earthwork1_px	Earthwork (Color 0) on Cross Sections	0	0 / Continuous	1
	typdrd	Earthwork2_px	Earthwork (Color 1) on Cross Sections	1	0 / Continuous	1
	typdrd	Earthwork3_px	Earthwork (Color 2) on Cross Sections	2	0 / Continuous	1
	typdrd	Earthwork4_px	Earthwork (Color 3) on Cross Sections	3	0 / Continuous	1
	typdrd	Earthwork5_px	Earthwork (Color 4) on Cross Sections	4	0 / Continuous	1
X	typdrd	EaseLicLine	Easement License Agreement Line	5	6 / DGN6	0
X	typdrd	EasePerpLine	Easement Lines Perpetual	4	RW-PerpetualEasement	1
X	typdrd	EasePerpLine_px	Easement Lines Perpetual on Cross Sections	4	RW-PerpetualEasement	1
X	typdrd	EaseTempLine	Easement Lines Temporary	6	RW-TemporaryEasement	0
X	typdrd	EaseTempLine_px	Easement Lines Temporary on Cross Sections	6	RW-TemporaryEasement	0
	typdrd	ElecBur_px	Electrical on Cross Sections (Buried)	3	0 / Continuous	1
X	typdrd	Endwall	Endwall (All Types)	10	0 / Continuous	2
X	typdrd	Endwall_px	Endwall on Cross Sections	10	0 / Continuous	2
	typdrd	ExcavationLimits_dp	Excavation Limits on Cross Sections	0	0 / Continuous	1
X	typdrd	Fence	Fence, Sand Fence	6	RD-Fence	1
	typdrd	Fence_ex	Fence Lines on Cross Sections (Existing)	6	3 / DGN3	1

Critical	Rule File	Level Name	Level Description	ByLevel Color	ByLevelStyle / Linetype	ByLevel Weight
X	typdrd	Fence_px	Fence Lines on Cross Sections	6	RD-Fence	2
X	typdrd	FenceLt	Fence Limited Access Left	6	RD-Fence	1
X	typdrd	FenceRt	Fence Limited Access Right	6	RD-Fence	1
X	typdrd	FES	Flared End Sections	10	0 / Continuous	2
X	typdrd	FES_px	Flared End Sections on Cross Sections	10	0 / Continuous	2
X	typdrd	Flagman	Flagman	6	0 / Continuous	2
X	typdrd	Gas_px	Gas Pipe and Fittings on Cross Sections (Miscellaneous)	4	0 / Continuous	1
	typdrd	GeotechFillPatt1	Geotechnical Fill Pattern - (Earth, Wood, Muck, Concrete, Rock, Riprap) as Defined in Project	3	0 / Continuous	0
	typdrd	GeotechFillPatt1_px	Geotechnical Fill Pattern on Cross Sections - (Earth, Wood, Muck, Concrete, Rock, Riprap) as Defined in Project	3	0 / Continuous	0
	typdrd	GeotechFillPatt2	Geotechnical Fill Pattern - Clay, Sand	0	1 / DGN1	0
	typdrd	GeotechFillPatt2_px	Geotechnical Fill Pattern on Cross Sections - Clay, Sand	0	1 / DGN1	0
	typdrd	GeotechFillPatt3	Geotechnical Fill Pattern - Shell	3	1 / DGN1	0
	typdrd	GeotechFillPatt3_px	Geotechnical Fill Pattern on Cross Sections - Shell	3	1 / DGN1	0
	typdrd	GeotechFillPatt4	Geotechnical Fill Pattern - Sand	4	0 / Continuous	0
	typdrd	GeotechFillPatt4_px	Geotechnical Fill Pattern on Cross Sections - Sand	4	0 / Continuous	0
	typdrd	GeotechFillPatt5	Geotechnical Fill Pattern - Coquina	1	0 / Continuous	1
	typdrd	GeotechFillPatt5_px	Geotechnical Fill Pattern on Cross Sections - Coquina	1	0 / Continuous	1
	typdrd	GeotechFillPatt6	Geotechnical Fill Pattern - Limestone	2	0 / Continuous	0
	typdrd	GeotechFillPatt6_px	Geotechnical Fill Pattern on Cross Sections - Limestone	2	0 / Continuous	0
	typdrd	GeotechFillPatt7	Geotechnical Fill Pattern - Gravel	6	0 / Continuous	0
	typdrd	GeotechFillPatt7_px	Geotechnical Fill Pattern on Cross Sections - Gravel	6	0 / Continuous	0
	typdrd	GeotechFillPatt8	Geotechnical Fill Pattern - Silt	0	0 / Continuous	1
	typdrd	GeotechFillPatt8_px	Geotechnical Fill Pattern on Cross Sections - Silt	0	0 / Continuous	1
	typdrd	GeotechMisc	Geotechnical Elements (Miscellaneous)	0	0 / Continuous	1
X	typdrd	GovTwpRgeLine_ep	Township / Range Lines (Existing)	10	RW-TownshipRange	2
	typdrd	GPKDrBack_dp	Back Point on Drainage Cells	2	2 / DGN2	2
	typdrd	GPKDrBottom_dp	Bottom Point on Drainage Cells	3	3 / DGN3	2
	typdrd	GPKDrCellIns_dp	Cell Insertion Point on Drainage Cells	4	4 / DGN4	2
	typdrd	GPKDrCentroid_dp	Point on Centroid for Drainage	7	7 / DGN7	2
	typdrd	GPKDrFront_dp	Front Point on Drainage Cells	1	1 / DGN1	2
	typdrd	GPKDrPipe_dp	Point on Drainage Pipe	6	6 / DGN6	2
	typdrd	GPKDrPipeCir_dp	Point on Pipe Circular	6	6 / DGN6	0
X	typdrd	Grass	Grass, Seeding and Mulching Areas	2	1 / DGN1	2
	typdrd	GridMaj_dp	Grid Lines Major in Profile and Cross Section	3	0 / Continuous	1
	typdrd	GridMin_dp	Grid Lines Minor in Profile and Cross Section	0	0 / Continuous	0
	typdrd	GridMinSub_dp	Grid Lines Minor Sub on Cross Section Sheets	20	0 / Continuous	0
	typdrd	GroundCover	Groundcover Edge Symbol	2	0 / Continuous	1
	typdrd	GroundCoverHatch	Groundcover Hatch Pattern	2	0 / Continuous	0
X	typdrd	Guardrail	Guardrail	1	0 / Continuous	1
X	typdrd	GuardrailBRLt	Guardrail Bridge (Left)	0	RD-Guardrail-Left	1
X	typdrd	GuardrailBRRt	Guardrail Bridge (Right)	0	RD-Guardrail-Right	1
X	typdrd	GuardrailDbI	Guardrail (Double Face)	0	RD-Guardrail-Double	1
X	typdrd	GuardrailEndAch	Guardrail (End Anchorage)	0	0 / Continuous	1
X	typdrd	GuardrailLt	Guardrail (Left)	0	RD-Guardrail-Left	1
X	typdrd	GuardrailModThrieDbI	Guardrail Modified Thrie Beam (Double Face)	0	RD-Guardrail-Double	1
X	typdrd	GuardrailModThrieLt	Guardrail Modified Thrie Beam (Left)	0	RD-Guardrail-Left	1
X	typdrd	GuardrailModThrieRt	Guardrail Modified Thrie Beam (Right)	0	RD-Guardrail-Right	1



Critical	Rule File	Level Name	Level Description	ByLevel Color	ByLevelStyle / Linetype	ByLevel Weight
X	typdrd	GuardrailPanel_px	Guardrail Component Property on Cross Sections for 3D Guardrail Panels	11	0 / Continuous	1
X	typdrd	GuardrailPost_px	Guardrail Component Property on Cross Sections for 3D Guardrail Posts	10	0 / Continuous	0
X	typdrd	GuardrailPRDbl	Guardrail Double Face w/ Pipe Rail	0	RD-Guardrail-Double	1
X	typdrd	GuardrailPRLt	Guardrail Left w/ Pipe Rail	0	RD-Guardrail-Left	1
X	typdrd	GuardrailPRRt	Guardrail Right w/ Pipe Rail	0	RD-Guardrail-Right	1
X	typdrd	GuardrailRRDbl	Guardrail Double Face w/ Rub Rail	0	RD-Guardrail-Double	1
X	typdrd	GuardrailRRLt	Guardrail Left w/ Rub Rail	0	RD-Guardrail-Left	1
X	typdrd	GuardrailRRRt	Guardrail Right w/ Rub Rail	0	RD-Guardrail-Right	1
X	typdrd	GuardrailRt	Guardrail Right	0	RD-Guardrail-Right	1
X	typdrd	GuardrailThrieDbl	Guardrail Thrie Beam Double Face	0	RD-Guardrail-Double	1
X	typdrd	GuardrailThrieLt	Guardrail Thrie Beam Left	0	RD-Guardrail-Left	1
X	typdrd	GuardrailThriePRLt	Guardrail Thrie Beam Left w/ Pipe Rail	0	RD-Guardrail-Left	1
X	typdrd	GuardrailThriePRRt	Guardrail Thrie Beam Right w/ Pipe Rail	0	RD-Guardrail-Right	1
X	typdrd	GuardrailThrieRt	Guardrail Thrie Beam Right	0	RD-Guardrail-Right	1
	typdrd	HardscapeDetails	Paving Details, Fence Railing, Stamped Asphalt	4	0 / Continuous	2
	typdrd	ImageAttachment_dp	Image Attachments	0	0 / Continuous	0
X	typdrd	Inlet_px	Inlets on Cross Sections	10	0 / Continuous	2
X	typdrd	InletBottom_px	Inlet Bottom on Cross Sections (All Types)	10	0 / Continuous	2
X	typdrd	InletBottomJ	Inlet Bottom Type J	10	0 / Continuous	1
X	typdrd	InletBottomP	Inlet Bottom Type P	10	0 / Continuous	1
X	typdrd	InletCurb	Curb Inlet (All Types)	10	0 / Continuous	2
X	typdrd	InletDBI	Ditch Bottom Inlet (All Types)	10	0 / Continuous	2
X	typdrd	InletGutter	Gutter Inlet (All Types)	10	0 / Continuous	2
X	typdrd	InletMedian	Median Barrier Inlet	10	0 / Continuous	2
	typdrd	KeyShtMisc	Key Sheet Items (Miscellaneous)	0	0 / Continuous	2
	typdrd	LaneDirArrow	Lane Directional Arrow	0	0 / Continuous	1
X	typdrd	LARWLine	Limited Access Right of Way Lines	4	RW-LimitedAccess-Proposed	2
X	typdrd	LARWLine_ep	Limited Access Right of Way Lines (Existing)	4	RW-LimitedAccess-Existing	1
X	typdrd	LARWLine_ex	Limited Access Right of Way Lines on Cross Sections (Existing)	4	RW-LimitedAccess-Existing	1
X	typdrd	LARWLine_px	Limited Access Right of Way Lines on Cross Sections	4	RW-LimitedAccess-Proposed	2
X	typdrd	LateralLimits_px	Lateral Limits on Cross Sections	6	0 / Continuous	2
	typdrd	LeaderLine_dp	Leader Line and Terminator with Text	0	0 / Continuous	1
	typdrd	LightingMisc	Lighting Items (Miscellaneous)	4	0 / Continuous	2
X	typdrd	LightingSP	Lighting Service Points	0	0 / Continuous	1
	typdrd	Logo_dp	Consultant Engineer of Record Logo	0	0 / Continuous	1
X	typdrd	Luminaire	Luminaires (Decorative - All Types)	2	0 / Continuous	1
X	typdrd	Manhole	Manhole (Drainage and Unknown)	10	0 / Continuous	2
X	typdrd	Manhole_px	Manhole on Cross Sections	10	0 / Continuous	2
X	typdrd	MES	Mitered End Section	10	0 / Continuous	2
X	typdrd	MES_px	Mitered End Section on Cross Sections	10	0 / Continuous	2
	typdrd	Miscellaneous0	Undefined Proposed Item - Color Blue Weight 0	1	0 / Continuous	0
	typdrd	Miscellaneous1	Undefined Proposed Item - Color Blue Weight 1	1	0 / Continuous	1
	typdrd	Miscellaneous2	Undefined Proposed Item - Color Blue Weight 2	1	0 / Continuous	2
	typdrd	Miscellaneous3	Undefined Proposed Item - Color Green Weight 0	2	0 / Continuous	0
	typdrd	Miscellaneous4	Undefined Proposed Item - Color Green Weight 1	2	0 / Continuous	1
	typdrd	Miscellaneous5	Undefined Proposed Item - Color Green Weight 2	2	0 / Continuous	2
	typdrd	Miscellaneous6	Undefined Proposed Item - Color Red Weight 0	3	0 / Continuous	0
	typdrd	Miscellaneous7	Undefined Proposed Item - Color Red Weight 1	3	0 / Continuous	1

Critical	Rule File	Level Name	Level Description	ByLevel Color	ByLevelStyle / Linetype	ByLevel Weight
	typdrd	Miscellaneous8	Undefined Proposed Item - Color Red Weight 2	3	0 / Continuous	2
	typdrd	Miscellaneous9	Undefined Proposed Item - Color Red Weight 3	3	0 / Continuous	3
	typdrd	NonPlottingEle_dp	Non-Plotting Items - Construction Elements, Type 66 Elements, Etc.	4	0 / Continuous	0
	typdrd	PatternLines1_dp	Pattern Lines on Cross Sections and All Autodesk (Civil 3D) Tables	3	0 / Continuous	2
	typdrd	PatternLines2_dp	Pattern Lines on Cross Sections Alternate for Side Streets, CriticalCross Sections or Drainage Structures	4	0 / Continuous	2
	typdrd	PatternLines3_dp	Pattern Lines on Cross Sections Alternate for Side Streets, CriticalCross Sections or Drainage Structures	5	0 / Continuous	2
X	typdrd	PavedMedianBase_px	Median Subgrade on Cross Sections (Paved)	3	0 / Continuous	2
X	typdrd	PavtAsphalt	Asphalt Pavement Edge Line and Quantity Shapes	0	0 / Continuous	2
	typdrd	PavtAsphalt_ep	Asphalt Pavement Edge (Existing)	0	3 / DGN3	1
X	typdrd	PavtAsphalt_px	Asphalt Pavement on Cross Sections and Components in Models	1	0 / Continuous	2
X	typdrd	PavtBase	Base Material (All Types)	3	0 / Continuous	2
X	typdrd	PavtBase_ex	Base Material on Cross Sections (All Types) (Existing)	3	3 / DGN3	1
X	typdrd	PavtBase_px	Base Material on Cross Sections (All Types)	3	0 / Continuous	2
X	typdrd	PavtConcrete	Concrete Pavement Edge Lines and Quantity Shapes	10	0 / Continuous	2
X	typdrd	PavtConcrete_px	Concrete Pavement on Cross Sections and Components in Models	0	0 / Continuous	2
X	typdrd	PavtConcreteSC	Concrete Surface Coloring	9	0 / Continuous	1
	typdrd	PavtCrown	Pavement Crown	16	0 / Continuous	2
X	typdrd	PavtMessage	Pavement Message (All Types)	0	0 / Continuous	1
X	typdrd	PavtMessage_ep	Pavement Message (All Types) (Existing)	0	2 / DGN2	0
X	typdrd	PavtMilling_px	Asphalt Milling Lines on Cross Sections	7	0 / Continuous	2
X	typdrd	PavtMisc	Asphalt Material (Miscellaneous)	1	0 / Continuous	1
X	typdrd	PavtMisc_px	Pavement on Cross Sections (Miscellaneous)	1	0 / Continuous	2
X	typdrd	PavtOverbuild_px	Pavement Overbuild Areas on Cross Sections - Component Property	4	0 / Continuous	2
X	typdrd	PavtOverlay_px	Pavement Overlay on Cross Sections - Component Property	1	0 / Continuous	2
X	typdrd	PavtOverlay1_px	Pavement Overlay on Cross Sections - Component Property	14	0 / Continuous	2
X	typdrd	PavtOverlay2_px	Pavement Overlay on Cross Sections - Component Property	7	0 / Continuous	2
X	typdrd	PavtStabilization	Stabilization Material Lines and Shapes	9	0 / Continuous	2
X	typdrd	PavtStabilization_px	Stabilization on Cross Sections	5	2 / DGN2	2
	typdrd	PayItem_dp	Pay Item Number Label Elements	4	0 / Continuous	2
	typdrd	PipeCulvert_ep	Pipe Culvert (Existing)	10	3 / DGN3	1
X	typdrd	PipeCulvert_pr	Pipe Culvert in Profile	10	0 / Continuous	2
X	typdrd	PipeCulvert_px	Pipe Culvert on Cross Section View	10	0 / Continuous	2
X	typdrd	PlotBorder_dp	Plot Border	3	0 / Continuous	0
	typdrd	PMMisc	Pavement Marking Items (Miscellaneous)	0	0 / Continuous	2
X	typdrd	PMStripe(10-10-20)	Pavement Marking 10/10/20 Skip Traffic Stripe 6in Contrast	0	PM-Stripe-10'_20'Skip / PM-Stripe-SKIP 10-10-20	2
X	typdrd	PMStripe(2-2-2)	Pavement Marking 2/2/2 Skip Traffic Stripe 6in Contrast	0	PM-Stripe-2'_2'Skip / PM-Stripe-SKIP 2-2-2	2
X	typdrd	PMStripe12B	Pavement Marking Traffic Stripe 12in Black	3	0 / Continuous	4
X	typdrd	PMStripe12W	Pavement Marking Traffic Stripe 12in White	0	0 / Continuous	4
X	typdrd	PMStripe12W(2-4)	Pavement Marking 2/4 Skip Traffic Stripe 12in White	0	0 / PM-Stripe-SKIP 2-4	4
X	typdrd	PMStripe12W(3-9)	Pavement Marking 3/9 Skip Traffic Stripe 12in White	0	0 / PM-Stripe-SKIP 3-9	4
X	typdrd	PMStripe12Y	Pavement Marking Traffic Stripe 12in Yellow	4	0 / Continuous	4
X	typdrd	PMStripe16B	Pavement Marking Traffic Stripe 16in Black	3	0 / Continuous	5
X	typdrd	PMStripe16W	Pavement Marking Traffic Stripe 16in White	0	0 / Continuous	5
X	typdrd	PMStripe16Y	Pavement Marking Traffic Stripe 16in Yellow	4	0 / Continuous	5
X	typdrd	PMStripe18B	Pavement Marking Traffic Stripe 18in Black	3	0 / Continuous	6
X	typdrd	PMStripe18W	Pavement Marking Traffic Stripe 18in White	0	0 / Continuous	6
X	typdrd	PMStripe18Y	Pavement Marking Traffic Stripe 18in Yellow	4	0 / Continuous	6

Critical	Rule File	Level Name	Level Description	ByLevel Color	ByLevelStyle / Linetype	ByLevel Weight
X	typdrd	PMStripe24W	Pavement Marking Traffic Stripe 24in White	0	0 / Continuous	7
X	typdrd	PMStripe24Y	Pavement Marking Traffic Stripe 24in Yellow	4	0 / Continuous	7
X	typdrd	PMStripe6B	Pavement Marking Traffic Stripe 6in Black	3	0 / Continuous	2
X	typdrd	PMStripe6B(10-30)	Pavement Marking 10/30 Skip Traffic Stripe 6in Black	3	0 /PM-Stripe-SKIP 10-30	2
X	typdrd	PMStripe6BI	Pavement Marking Traffic Stripe 6in Blue	1	0 / Continuous	2
X	typdrd	PMStripe6DY	Pavement Marking Traffic Stripe 6in Double Yellow	4	0 / Continuous	2
X	typdrd	PMStripe6W	Pavement Marking Traffic Stripe 6in White	0	0 / Continuous	2
X	typdrd	PMStripe6W(10-30)	Pavement Marking 10/30 Skip Traffic Stripe 6in White	0	0 /PM-Stripe-SKIP 10-30	2
X	typdrd	PMStripe6W(2-4)	Pavement Marking 2/4 Skip Traffic Stripe 6in White	0	0 /PM-Stripe-SKIP 2-4	2
X	typdrd	PMStripe6W(3-9)	Pavement Marking 3/9 Skip Traffic Stripe 6in White	0	0 /PM-Stripe-SKIP 3-9	2
X	typdrd	PMStripe6W(6-10)	Pavement Marking 6/10 Skip Traffic Stripe 6in White	0	0 /PM-Stripe-SKIP 6-10	2
X	typdrd	PMStripe6Y	Pavement Marking Traffic Stripe 6in Yellow	4	0 / Continuous	2
X	typdrd	PMStripe6Y(10-30)	Pavement Marking 10/30 Skip Traffic Stripe 6in Yellow	4	0 /PM-Stripe-SKIP 10-30	2
X	typdrd	PMStripe6Y(2-4)	Pavement Marking 2/4 Skip Traffic Stripe 6in Yellow	4	0 /PM-Stripe-SKIP 2-4	2
X	typdrd	PMStripe6Y(6-10)	Pavement Marking 6/10 Skip Traffic Stripe 6in Yellow	4	0 /PM-Stripe-SKIP 6-10	2
X	typdrd	PMStripe8B	Pavement Marking Traffic Stripe 8in Black	3	0 / Continuous	3
X	typdrd	PMStripe8W	Pavement Marking Traffic Stripe 8in White	0	0 / Continuous	3
X	typdrd	PMStripe8W(3-9)	Pavement Marking 3/9 Skip Traffic Stripe 8in White	0	0 /PM-Stripe-SKIP 3-9	2
X	typdrd	PMStripe8Y	Pavement Marking Traffic Stripe 8in Yellow	4	0 / Continuous	3
X	typdrd	PMStripe9C(10-30)	Pavement Marking 10/30 Skip Traffic Stripe 9in Contrast	0	0 / PM-Stripe-SKIP 10-30	2
X	typdrd	PMStripeRumbleCL	Center Line Rumble Stripes (Use to Quantify Rumble Strips) (NonPlotting)	4	PM-Stripe-RumbleStripeLeft / PM-Stripe-RumbleStripe	2
X	typdrd	PMStripeRumbleWL	Rumble Stripes (6in White Thermoplastic Over Rumble Strips) (Left)	0	PM-Stripe-RumbleStripeLeft / PM-Stripe-RumbleStripe	2
X	typdrd	PMStripeRumbleWR	Rumble Stripes (6in White Thermoplastic Over Rumble Strips) (Right)	0	PM-Stripe-RumbleStripeRight / PM-Stripe-RumbleStripe	2
X	typdrd	PMStripeRumbleYL	Rumble Stripes (6in Yellow Thermoplastic Over Rumble Strips) (Left)	4	PM-Stripe-RumbleStripeLeft / PM-Stripe-RumbleStripe	2
X	typdrd	PMStripeRumbleYR	Rumble Stripes (6in Yellow Thermoplastic Over Rumble Strips) (Right)	4	PM-Stripe-RumbleStripeRight / PM-Stripe-RumbleStripe	2
X	typdrd	PMStripeVibeWL	Pavement Marking Auditory and Vibratory 6in White (Left)	0	PM-Stripe-VibratoryLeft /PM-Stripe-Vibratory	2
X	typdrd	PMStripeVibeWR	Pavement Marking Auditory and Vibratory 6in White (Right)	0	PM-Stripe-VibratoryRight /PM-Stripe-Vibratory	2
X	typdrd	PMStripeVibeYL	Pavement Marking Auditory and Vibratory 6in Yellow (Left)	4	PM-Stripe-VibratoryLeft /PM-Stripe-Vibratory	2
X	typdrd	PMStripeVibeYR	Pavement Marking Auditory and Vibratory 6in Yellow (Right)	4	PM-Stripe-VibratoryRight /PM-Stripe-Vibratory	2
	typdrd	PointLocator_ep	Point Locator Symbol (Existing)	4	0 / Continuous	0
X	typdrd	PoleConc	Concrete Strain Pole	0	0 / Continuous	2
X	typdrd	PoleConc_ep	Concrete Strain Pole (Existing)	0	2 / DGN2	1
X	typdrd	PoleFound	Pole Foundation	0	0 / Continuous	2
X	typdrd	PoleLight	Light Pole	2	0 / Continuous	1
X	typdrd	PoleLight_ep	Light Pole (Existing)	2	2 / DGN2	1
X	typdrd	PoleLightHM	High Mast Light Pole	3	0 / Continuous	1
X	typdrd	PoleLightHM_ep	High Mast Light Pole (Existing)	2	2 / DGN2	1
	typdrd	PoleLightID	Light Pole Location / ID	4	0 / Continuous	1
X	typdrd	Pond_px	Pond Lines on Cross Sections	2	0 / Continuous	2
X	typdrd	PropertyLine_ep	Property Lines (Existing)	3	0 / Continuous	0
X	typdrd	PvtAnalysisCrown_px	Pavement Analysis Crowning on Cross Sections - Component Property	7	0 / Continuous	1
X	typdrd	PvtAnalysisFail_px	Pavement Analysis Failure on Cross Sections - Component Property	3	0 / Continuous	1
X	typdrd	PvtAnalysisMax_px	Pavement Analysis Acceptable Maximum Range on Cross Sections - Component Property	5	0 / Continuous	1
X	typdrd	PvtAnalysisMin_px	Pavement Analysis Acceptable Minimum Range on Cross Sections - Component Property	4	0 / Continuous	1

Critical	Rule File	Level Name	Level Description	ByLevel Color	ByLevelStyle / Linetype	ByLevel Weight
X	typdrd	PvtAnalysisOptiml_px	Pavement Analysis Optimal on Cross Sections - Component Property	2	0 / Continuous	1
X	typdrd	Railing	Railings; Piperail, Guiderail, Handrail Used for Pedestrian and Bicycles (All)	9	0 / Continuous	2
X	typdrd	Railing_px	Railing Components and Cross Section Shapes	9	0 / Continuous	2
	typdrd	ReferencePt_dp	Survey and Construction Reference Point Details and Elements	4	0 / Continuous	2
X	typdrd	RipRap_px	Rip Rap, Rubble on Cross Sections	4	1 / DGN1	2
X	typdrd	RWLine	Right of Way Lines	4	RW-Proposed	2
X	typdrd	RWLine_ep	Right of Way Lines (Existing)	3	RW-Existing	1
X	typdrd	RWLine_ex	Right of Way Lines on Cross Sections (Existing)	3	RW-Existing	1
X	typdrd	RWLine_px	Right of Way Lines on Cross Sections	4	RW-Proposed	2
X	typdrd	SanitaryFM_px	Force Main Lines on Cross Sections	2	0 / Continuous	1
X	typdrd	SanitarySewer_ex	Sanitary Sewer on Cross Sections (Existing)	2	2 / DGN2	0
X	typdrd	SanitarySewer_px	Sanitary Sewer on Cross Sections	2	0 / Continuous	1
	typdrd	Scratch1_dp	Scratch Level for Temporary or Informational Items	4	0 / Continuous	0
	typdrd	Scratch2_dp	Scratch Level for Temporary or Informational Items	5	0 / Continuous	0
	typdrd	ScratchEle_dp	Scratch Level for Draft Elements, Temporary Elements, Etc. (DO NOT PLOT)	3	0 / Continuous	0
	typdrd	ScratchEle2_dp	Scratch Level for Draft Elements, Temporary Elements, Etc. (DO NOT PLOT)	4	0 / Continuous	0
	typdrd	SheetBorder_dp	Sheet Border	1	0 / Continuous	4
	typdrd	SheetLines_dp	Sheet Lines	1	0 / Continuous	2
	typdrd	SheetLinesMisc1_dp	Sheet Lines	1	0 / Continuous	0
	typdrd	SheetLinesMisc2_dp	Sheet Lines	2	0 / Continuous	2
	typdrd	SheetLinesMisc3_dp	Sheet Lines	3	0 / Continuous	2
	typdrd	SheetLinesMisc4_dp	Sheet Lines	4	0 / Continuous	2
X	typdrd	ShldrBase_px	Shoulder Base on Cross Sections	3	0 / Continuous	2
	typdrd	ShldrHatch	Shoulder Hatch Pattern	1	0 / RD-PavedShldr6	1
X	typdrd	ShldrMilling_px	Shoulder Milling Component on Cross Sections - Component Property	7	0 / Continuous	2
X	typdrd	ShldrOverbuild_px	Shoulder Overbuild on Cross Sections - Component Property	4	0 / Continuous	1
X	typdrd	ShldrOverlay_px	Shoulder Overlay on Cross Sections - Component Property	1	0 / Continuous	1
X	typdrd	ShldrPaved	Shoulder Line (Paved)	1	0 / Continuous	1
X	typdrd	ShldrPaved_px	Shoulder Lines on Cross Sections (Paved)	1	0 / Continuous	2
X	typdrd	ShldrUnpaved	Shoulder Line (Unpaved)	0	0 / Continuous	0
X	typdrd	ShldrUnpaved_px	Shoulder Lines on Cross Sections (Unpaved)	2	0 / Continuous	2
X	typdrd	Shrub	Shrubs	2	0 / Continuous	1
X	typdrd	Sidewalk_ex	Sidewalk Elements on Cross Sections (Existing)	0	2 / DGN2	1
X	typdrd	Sidewalk_px	Sidewalk Elements on Cross Sections	0	0 / Continuous	2
X	typdrd	SidewalkBack	Back of Sidewalk	2	0 / Continuous	1
X	typdrd	SidewalkBase_px	Sidewalk Subgrade on Cross Sections	3	0 / Continuous	2
X	typdrd	SidewalkConc	Sidewalk Concrete Shape	0	0 / Continuous	2
X	typdrd	SidewalkFront	Front of Sidewalk	1	0 / Continuous	1
X	typdrd	SignalWorkZone	Traffic Signal / Portable Signal	3	0 / Continuous	2
X	typdrd	SignWorkZone	Work Zone Signs	6	0 / Continuous	2
X	typdrd	Slopes	Slopes (Top, Bottom)	9	3 / DGN3	0
X	typdrd	Slopes_px	Slope Lines on Cross Sections	9	0 / Continuous	2
X	typdrd	Sod	Performance Sod	2	0 / Continuous	2
X	typdrd	SoilBoxes_px	Soil Boxes and Borings on Cross Sections	4	0 / Continuous	1
	typdrd	SpecialDetails_px	Special Details on Cross Sections	6	0 / Continuous	1
	typdrd	StationTicL_dp	Station Tic Marks (Large) and Text	0	0 / Continuous	2
	typdrd	StationTicS_dp	Station Tic Marks (Small) and Text	0	0 / Continuous	2
X	typdrd	StreetLights	Street Lights	2	0 / Continuous	1

Critical	Rule File	Level Name	Level Description	ByLevel Color	ByLevelStyle / Linetype	ByLevel Weight
X	typdrd	StreetLights_px	Street Lights on Cross Sections	3	0 / Continuous	1
	typdrd	Structure_px	Signal and Sign Structures on Cross Sections	0	0 / Continuous	2
X	typdrd	SubDsgn_px	Sub Design on Cross Sections Including Sub-base	4	0 / Continuous	1
X	typdrd	Subsoil_px	Subsoil or Undercut on Cross Sections	4	0 / Continuous	2
X	typdrd	SubsoilFinal_px	Subsoil Final for Multiline on Cross Sections	18	0 / Continuous	1
X	typdrd	SubsoilProp_px	Subsoil Proposed for Multiline on Cross Sections	8	0 / Continuous	1
	typdrd	SumBoxBorder_dp	Summary Boxes Borders	4	0 / Continuous	3
	typdrd	SumBoxLines_dp	Summary Boxes Lines and Miscellaneous Items	4	0 / Continuous	1
	typdrd	SumBoxLinesMin_dp	Summary Boxes Lines Minor Line and Miscellaneous Items	4	0 / Continuous	0
	typdrd	Tables_dp	Data Tables and All Autodesk Tables	0	0 / Continuous	1
X	typdrd	TemplateBottom_px	Bottom of Template for Multiline on Cross Sections	6	0 / Continuous	1
X	typdrd	TemplateFinal_px	Final Template for Multiline on Cross Sections	2	0 / Continuous	1
X	typdrd	TemplateTop_px	Top of Template for Multiline on Cross Sections	7	0 / Continuous	1
X	typdrd	TerrainLine_ex	Ground Line for Multiline on Cross Sections (Existing)	5	0 / Continuous	1
	typdrd	TextBLStation	Text - B/L Station and Tics	0	0 / Continuous	2
	typdrd	TextConstEle	Text - Construction Element	0	0 / Continuous	1
	typdrd	TextCurveData	Text - Curve Data Note	0	0 / Continuous	2
	typdrd	TextDetails	Text - Detail Notes	4	0 / Continuous	2
	typdrd	TextDrainInvElev_ep	Text - Drainage Invert Elevation (Existing)	0	0 / Continuous	1
	typdrd	TextDrainLabel_ep	Text - Drainage (Existing)	0	0 / Continuous	1
	typdrd	TextElevLabel	Text - Elevation Labels	4	0 / Continuous	0
	typdrd	TextGeotech	Text - Soil Borings and Labels	0	0 / Continuous	2
	typdrd	TextLabel	Text - Label	0	0 / Continuous	2
	typdrd	TextLandscape	Text - Landscape Labels	0	0 / Continuous	1
	typdrd	TextMajor	Text - Major	0	0 / Continuous	5
	typdrd	TextMinor	Text - Minor	0	0 / Continuous	0
	typdrd	TextMisc	Text - Miscellaneous	0	0 / Continuous	1
	typdrd	TextNotes	Text - Notes	4	0 / Continuous	1
	typdrd	TextProfLabel	Text - Profile, Horizontal and Vertical Axis Labels	0	0 / Continuous	2
	typdrd	TextProjLabel	Text - Begin and End Project Label with Leader Lines	1	0 / Continuous	2
	typdrd	TextPtLabel	Text - Point Labels	4	0 / Continuous	0
	typdrd	TextShtNo	Text - Sheet Number	0	0 / Continuous	2
	typdrd	TextSubUtilLabel_ep	Text - Subsurface Utilities (Existing)	0	0 / Continuous	1
	typdrd	TextSurveyLabel	Text - Survey Labels	0	0 / Continuous	0
	typdrd	TextTables	Text - Key Sheet Indexes and Table Data	4	0 / Continuous	2
	typdrd	TextTitle	Text - Title	0	0 / Continuous	3
	typdrd	TextTopoLabel_ep	Text - Topography (Existing)	0	0 / Continuous	1
	typdrd	TextUtilLabel_ep	Text - Utilities (Existing)	0	0 / Continuous	1
	typdrd	TextXSElev	Text - Cross Section Elevations	2	0 / Continuous	1
X	typdrd	TrafficControlMisc	Traffic Control Items (Miscellaneous)	3	0 / Continuous	1
X	typdrd	TrafSeparator	Traffic Separator (All Types)	6	0 / Continuous	1
X	typdrd	TrafSeparator_px	Traffic Separator on Cross Sections (All Types)	6	0 / Continuous	2
X	typdrd	TrafSeparatorBase_px	Traffic Separator Subgrade on Cross Sections	3	0 / Continuous	2
X	typdrd	Tree	Trees, Tree Line Pattern	2	0 / Continuous	1
X	typdrd	TreeGrate	Tree Grate	5	0 / Continuous	1
X	typdrd	TreeProtection	Tree Protection Symbol	5	0 / Continuous	2
X	typdrd	TubularMarker_px	Tubular Markers on Typical	6	0 / Continuous	2
X	typdrd	Turf	Performance Turf	100	0 / Continuous	2

Critical	Rule File	Level Name	Level Description	ByLevel Color	ByLevelStyle / Linetype	ByLevel Weight
	typdrd	TypicalMisc	Typical Items (Miscellaneous)	0	0 / Continuous	2
X	typdrd	UnderDrain	Underdrains (All Types)	10	0 / Continuous	2
	typdrd	UtilsMisc_px	Utility Items on Cross Sections (Miscellaneous)	8	0 / Continuous	1
	typdrd	Vehicle	Vehicle for Calculating Turning Radius	7	0 / Continuous	2
	typdrd	Viewport	Viewport (For AutoCAD Use)	3	0 / Continuous	0
	typdrd	VoidArea_dx	Void Area on Cross Sections	1	0 / Continuous	0
X	typdrd	WallBarrier	Barrier Wall (All Types)	6	0 / Continuous	2
X	typdrd	WallBarrier_ex	Barrier Wall on Cross Section (Existing)	6	3 / DGN3	1
X	typdrd	WallBarrier_px	Barrier Wall on Cross Section	6	0 / Continuous	2
X	typdrd	WallFooter_px	Wall Footer (Concrete) on Cross Sections - Component Symbology/Material on All Wall Footers/Leveling Pads	2	0 / Continuous	1
X	typdrd	WallGravBase_px	Gravity Wall Subgrade on Cross Sections	3	0 / Continuous	2
X	typdrd	WallGravity	Gravity Wall	11	0 / Continuous	1
X	typdrd	WallGravity_px	Gravity Wall on Cross Sections	11	0 / Continuous	2
X	typdrd	WallMedianBase_px	Median Wall Subgrade on Cross Sections	3	0 / Continuous	2
X	typdrd	WallRetain	Retaining Wall System	6	0 / Continuous	1
X	typdrd	WallRetain_pr	Retaining Wall Profile	9	0 / Continuous	2
X	typdrd	WallRetain_px	Retaining Walls on Cross Sections	6	0 / Continuous	1
X	typdrd	WallShldrBase_px	Shoulder Wall Subgrade on Cross Sections	3	0 / Continuous	2
X	typdrd	WallTempBarrier_px	Barrier Wall (Temporary) on Typical	6	0 / Continuous	2
X	typdrd	Water_ex	Water on Cross Sections (Existing)	1	2 / DGN2	1
X	typdrd	Water_px	Water on Cross Sections	1	0 / Continuous	1
	typdrd	Xreference01_dp	Reference Files (For AutoCAD Use)	0	0 / Continuous	1
	typdrd	Xreference02_dp	Reference Files (For AutoCAD Use)	0	0 / Continuous	1
	typdrd	Xreference03_dp	Reference Files (For AutoCAD Use)	0	0 / Continuous	1
	typdrd	Xreference04_dp	Reference Files (For AutoCAD Use)	0	0 / Continuous	1
X	typdrd	XSBaseTop_px	Cross Section Top of Base	3	0 / Continuous	2
	typdrd	XSCell	GEOPAK Cross Section Cell/Block and Profile Cell/Block	8	0 / Continuous	1
X	typdrd	XSExtendGrdLine_ex	Cross Section Extend Ground Lines (Existing)	21	2 / DGN2	1
X	typdrd	XSGrdLine_ex	Cross Section Ground Lines (Existing)	2	2 / DGN2	1
X	typdrd	XSGrdLine_px	Cross Section Roadway Ground Lines	1	0 / Continuous	2
	typdrd	XSMisc_px	Cross Section Items (Miscellaneous)	0	0 / Continuous	2
	typdrd	XSShapeDep01_dp	Cross Section Shape Dependent	11	0 / Continuous	2
	typdrd	XSShapeDep02_dp	Cross Section Shape Dependent	12	0 / Continuous	2
	typdrd	XSShapeDep03_dp	Cross Section Shape Dependent	13	0 / Continuous	2
	typdrd	XSShapeDep04_dp	Cross Section Shape Dependent	14	0 / Continuous	2
	typdrd	XSShapeDep05_dp	Cross Section Shape Dependent	15	0 / Continuous	2
	typdrd	XSShapeDep06_dp	Cross Section Shape Dependent	16	0 / Continuous	2
	typdrd	XSShapeDep07_dp	Cross Section Shape Dependent	17	0 / Continuous	2
	typdrd	XSShapeDep08_dp	Cross Section Shape Dependent	18	0 / Continuous	2
	typdrd	XSShapeDep09_dp	Cross Section Shape Dependent	19	0 / Continuous	2
	typdrd	XSShapeDep10_dp	Cross Section Shape Dependent	20	0 / Continuous	2
	typdrd	XSShapeIndep01_dp	Cross Section Shape Independent	1	0 / Continuous	2
	typdrd	XSShapeIndep02_dp	Cross Section Shape Independent	2	0 / Continuous	2
	typdrd	XSShapeIndep03_dp	Cross Section Shape Independent	3	0 / Continuous	2
	typdrd	XSShapeIndep04_dp	Cross Section Shape Independent	4	0 / Continuous	2
	typdrd	XSShapeIndep05_dp	Cross Section Shape Independent	5	0 / Continuous	2
	typdrd	XSShapeIndep06_dp	Cross Section Shape Independent	6	0 / Continuous	2



Critical	Rule File	Level Name	Level Description	ByLevel Color	ByLevelStyle / Linetype	ByLevel Weight
	typdrd	XSShapeIndep07_dp	Cross Section Shape Independent	7	0 / Continuous	2
	typdrd	XSShapeIndep08_dp	Cross Section Shape Independent	8	0 / Continuous	2
	typdrd	XSShapeIndep09_dp	Cross Section Shape Independent	9	0 / Continuous	2
	typdrd	XSShapeIndep10_dp	Cross Section Shape Independent	10	0 / Continuous	2
X	typdrd	XSTypical_px	Cross Section Roadway Pavement Typical	1	0 / Continuous	2

## UTARDR - Utilities Adjustment

Critical	Rule File	Level Name	Level Description	ByLevel Color	ByLevel Style	ByLevel Weight	Point /Line	Feature Code
	utadr	ActivePointCell_dp	Active Point Cell	4	0 / Continuous	10		
	utadr	AdhocPoint_dp	Adhoc Points Placed by SheetInfo	0	4 / DGN4	0		
	utadr	Beacons_ep	Beacons and Path Illumination (Existing)	0	0 / Continuous	1	P	BN
X	utadr	Capacitor	Capacitors (All Types)	3	0 / Continuous	2		
	utadr	Casing	Casing	0	UT-Casing-Proposed	2		
X	utadr	CATVAer	Cable TV Line (Aerial)	6	UT-OverheadCable-Proposed	2		
	utadr	CATVAer_ep	Cable TV Line (Aerial) (Existing)	6	UT-OverheadCable-Existing	1	L	CATV
X	utadr	CATVBur	Cable TV Line (Buried)	6	UT-BuriedCable-Proposed	2		
X	utadr	CATVBur_px	Cable TV and Miscellaneous on Cross Sections (Buried)	6	0 / Continuous	1		
	utadr	CATVBurB_ep	Cable TV Line Quality Level B Locate (Buried) (Existing)	6	UT-BuriedCable-Existing(B)	1		
	utadr	CATVBurC_ep	Cable TV Line Quality Level C Locate (Buried) (Existing)	6	UT-BuriedCable-Existing(C)	1		
	utadr	CATVBurD_ep	Cable TV Line Quality Level D Locate (Buried) (Existing)	6	UT-BuriedCable-Existing(D)	1		
X	utadr	CATVCond	Cable TV Conduit System	6	SG-Conduit	2		
	utadr	CATVCondBurB_ep	Cable TV Conduit System Quality Level B Locate (Buried) (Existing)	6	UT-BuriedCable-Existing(B)	1	L	CATVCB
	utadr	CATVCondBurC_ep	Cable TV Conduit System Quality Level C Locate (Buried) (Existing)	6	UT-BuriedCable-Existing(C)	1	L	CATVCC
	utadr	CATVCondBurD_ep	Cable TV Conduit System Quality Level D Locate (Buried) (Existing)	6	UT-BuriedCable-Existing(D)	1	L	CATVCD
	utadr	CATVMisc	Cable TV Service Box and Miscellaneous	6	0 / Continuous	2		
	utadr	CATVMisc_ep	Cable TV Service Box and Miscellaneous, Pole (Existing)	6	1 / DGN1	1	P	CATVS
	utadr	COGO_dp	COGO Information	3	0 / Continuous	1		
X	utadr	Conduit	Conduit for Utilities and Encasements	3	SG-Conduit	2		
	utadr	ConduitB_ep	Utility Conduit & Encasements Quality Level B Locate (Existing)	3	UT-Casing-Existing(B)	1		
	utadr	ConduitC_ep	Utility Conduit & Encasements Quality Level C Locate (Existing)	3	UT-Casing-Existing(C)	1		
	utadr	ConduitD_ep	Utility Conduit & Encasements Quality Level D Locate (Existing)	3	UT-Casing-Existing(D)	1		
X	utadr	ConduitAG	Conduit (Above Ground)	4	SG-ConduitAG-Proposed	1		
X	utadr	ConduitBM	Conduit – Bridge Mount	5	SG-ConduitBM-Proposed	1		
X	utadr	ConduitDB	Conduit – Directional Bore	2	SG-ConduitDB-Proposed	1		
X	utadr	ConduitJB	Conduit – Jack & Bore Under Rail	3	SG-ConduitJB-Proposed	1		
X	utadr	ConduitOT	Conduit – Open Trench	1	SG-ConduitOT-Proposed	1		
	utadr	ConstLines	Construction Lines and Preferences	1	0 / Continuous	0		
	utadr	ConstLines_pm	Construction Lines	4	0 / Continuous	0		
X	utadr	Controller_ep	Controller and Accessories (Existing)	0	2 / DGN2	1		
X	utadr	ControllerB_ep	Controller - Base Mounted (Existing)	0	2 / DGN2	1		
X	utadr	ControllerP_ep	Controller Pole Mount (Existing)	0	2 / DGN2	1		
	utadr	Core_ep	Core Sample or Test Hole (Existing)	9	0 / Continuous	0	P	CSH
	utadr	DimLines_dp	Dimension Lines, Corresponding Terminators, Equation Lines	0	0 / Continuous	1		
	utadr	Duct	Duct Pipe (Buried)	7	UT-Duct-Proposed	2		

Critical	Rule File	Level Name	Level Description	ByLevel Color	ByLevel Style	ByLevel Weight	Point /Line	Feature Code
	utadr	DummyChains_ep	Dummy Chains (Existing)	0	0 / Continuous	1	L	DUMB
X	utadr	EaseLicLine	Easement License Agreement Line	5	6 / DGN6	0		
X	utadr	ElecAer	Electrical Lines (Aerial)	3	UT-OverheadElec-Proposed	2		
	utadr	ElecAer_ep	Electrical Conductors (Distribution & Transmission) (Aerial) (Existing)	3	UT-OverheadElec-Existing	1		
	utadr	ElecAerPri_ep	Conductors (Primary Distribution) (Aerial) (Existing)	3	UT-OverheadElec-Existing	1	L	PRI
	utadr	ElecAerSec_ep	Conductors (Secondary Distribution) (Aerial) (Existing)	3	UT-OverheadElec-Existing	1		
X	utadr	ElecBur	Electrical (Buried)	3	UT-BuriedElec-Proposed	2		
	utadr	ElecBurB_ep	Electrical Quality Level B Locate (Buried) (Existing)	3	UT-BuriedElec-Existing(B)	1		
	utadr	ElecBurC_ep	Electrical Quality Level C Locate (Buried) (Existing)	3	UT-BuriedElec-Existing(C)	1		
	utadr	ElecBurCap_ep	Capacitors (Buried) (Existing)	3	1 / DGN1	1	L	CAPB
	utadr	ElecBurD_ep	Electrical Quality Level D Locate (Buried) (Existing)	3	UT-BuriedElec-Existing(D)	1		
	utadr	ElecBurPriB_ep	Conductors (Primary Distribution) Quality Level B Locate (Buried) (Existing)	3	UT-BuriedElec-Existing(B)	1		
	utadr	ElecBurPriC_ep	Conductors (Primary Distribution) Quality Level C Locate (Buried) (Existing)	3	UT-BuriedElec-Existing(C)	1		
	utadr	ElecBurPriD_ep	Conductors (Primary Distribution) Quality Level D Locate (Buried) (Existing)	3	UT-BuriedElec-Existing(D)	1		
	utadr	ElecBurSecB_ep	Conductor (Secondary Distribution) Quality Level B Locate (Buried) (Existing)	3	UT-BuriedElec-Existing(B)	1		
	utadr	ElecBurSecC_ep	Conductor (Secondary Distribution) Quality Level C Locate (Buried) (Existing)	3	UT-BuriedElec-Existing(C)	1		
	utadr	ElecBurSecD_ep	Conductor (Secondary Distribution) Quality Level D Locate (Buried) (Existing)	3	UT-BuriedElec-Existing(D)	1		
	utadr	ElecMisc	Fuses, Reclosures, Regulator, Sectionalizers	3	0 / Continuous	2		
	utadr	ElecMisc_ep	Capacitors (Above Ground), Switchgear, Transformer, Electrical Service Box (Existing)	3	1 / DGN1	1		
X	utadr	ElecOutlet	Electrical Outlet	3	0 / Continuous	2		
	utadr	ElecOutlet_ep	Electrical Outlet (Existing)	3	1 / DGN1	1	P	ELEO
X	utadr	ElecServ	Electrical Service (Miscellaneous)	3	0 / Continuous	2		
X	utadr	ElecServWire	Electrical Service Wire	3	0 / Continuous	2		
X	utadr	FireHydrant	Fire Hydrant	1	0 / Continuous	2		
	utadr	FireHydrant_ep	Fire Hydrant (Existing)	1	1 / DGN1	1	P	FH
	utadr	FloodLight_ep	Flood Light (Existing)	3	1 / DGN1	1	P	FLD
X	utadr	FOCAer	Fiber Optics Cable (Aerial)	6	UT-OverheadFOC-Proposed	2		
X	utadr	FOCBur	Fiber Optics Cable (Buried)	6	UT-BuriedFOC-Proposed	2		
	utadr	FOCBurB_ep	Fiber Optics Cable Quality Level B Locate (Buried) (Existing)	6	UT-BuriedFOC(B)-Existing	1		
	utadr	FOCBurC_ep	Fiber Optics Cable Quality Level C Locate (Buried) (Existing)	6	UT-BuriedFOC(C)-Existing	1		
	utadr	FOCBurD_ep	Fiber Optics Cable Quality Level D Locate (Buried) (Existing)	6	UT-BuriedFOC(D)-Existing	1		
X	utadr	FOEElecAer	Fiber Optics Electrical (Aerial)	3	UT-OverheadFOE-Proposed	2		
X	utadr	FOEElecAer_ep	Fiber Optics Electrical (Aerial) (Existing)	3	UT-OverheadFOE-Existing	2		
X	utadr	FOEElecBur	Fiber Optics Electrical (Buried)	3	UT-BuriedFOE-Proposed	2		
	utadr	FOEElecBurB_ep	Fiber Optics Electrical Quality Level B Locate (Buried) (Existing)	3	UT-BuriedFOE(B)-Existing	1		
	utadr	FOEElecBurC_ep	Fiber Optics Electrical Quality Level C Locate (Buried) (Existing)	3	UT-BuriedFOE(C)-Existing	1		
	utadr	FOEElecBurD_ep	Fiber Optics Electrical Quality Level D Locate (Buried) (Existing)	3	UT-BuriedFOE(D)-Existing	1		
X	utadr	FOTAer	Fiber Optics Telephone (Aerial) (Size Unknown)	6	UT-OverheadFOT-Proposed	2		
	utadr	FOTAer_ep	Fiber Optics Telephone (Aerial) (Size Unknown) (Existing)	6	UT-OverheadFOT-Existing	2		
X	utadr	FOTBur	Fiber Optics Telephone (Buried) (Size Unknown)	6	UT-BuriedFOT-Proposed	2		
	utadr	FOTBurB_ep	Fiber Optics Telephone Quality Level B Locate (Buried) (Size Unknown) (Existing)	6	UT-BuriedFOT(B)-Existing	1		
	utadr	FOTBurC_ep	Fiber Optics Telephone Quality Level C Locate (Buried) (Size Unknown) (Existing)	6	UT-BuriedFOT(C)-Existing	1		
	utadr	FOTBurD_ep	Fiber Optics Telephone Quality Level D Locate (Buried) (Size Unknown) (Existing)	6	UT-BuriedFOT(D)-Existing	1		
X	utadr	Gas	Gas Pipe and Fittings	4	UT-Gas-Proposed	2		
	utadr	Gas_ep	Gas Test & Miscellaneous (Existing)	4	1 / DGN1	1		
	utadr	GasB_ep	Gas Line (all sizes) Quality Level B Locate (Existing)	4	UT-Gas-Existing(B)	1		



Critical	Rule File	Level Name	Level Description	ByLevel Color	ByLevel Style	ByLevel Weight	Point /Line	Feature Code
	utadrd	GasC_ep	Gas Line (all sizes) Quality Level C Locate (Existing)	4	UT-Gas-Existing(C)	1		
	utadrd	GasD_ep	Gas Line (all sizes) Quality Level D Locate (Existing)	4	UT-Gas-Existing(D)	1		
	utadrd	GasMisc	Gas Regulator and Miscellaneous Items	4	0 / Continuous	2		
	utadrd	GasReg_ep	Gas Regulator (Existing)	4	1 / DGN1	1	P	RG
X	utadrd	Gauges	Gauges	0	0 / Continuous	2		
	utadrd	Gauges_ep	Gauges (Existing)	0	1 / DGN1	1	P	GA
X	utadrd	Generator	Emergency Generator	0	0 / Continuous	2		
	utadrd	GridMaj_dp	Grid Lines Major in Profile and Cross Section	3	0 / Continuous	1		
	utadrd	GridMin_dp	Grid Lines Minor in Profile and Cross Section	0	0 / Continuous	0		
	utadrd	GridMinSub_dp	Grid Lines Minor Sub on Cross Section Sheets	20	0 / Continuous	0		
X	utadrd	GuyWire	Guy Wire	3	0 / Continuous	2		
	utadrd	GuyWire_ep	Guy Anchor, Guy Pole, Span Guys (Existing)	3	1 / DGN1	1		
	utadrd	ImageAttachment_dp	Image Attachments	0	0 / Continuous	0		
X	utadrd	InterconCable_ep	Interconnect Cable (Existing)	1	SG-InterconCable-Existing	0		
X	utadrd	JunctBox	Junction Boxes, Service Cabinet (Elec/Tel)	3	0 / Continuous	2		
	utadrd	JunctBox_ep	Junction Boxes, Service Cabinet (Elec/Tel) (Existing)	3	1 / DGN1	1	P	SRVC
X	utadrd	JunctBoxA	Junction Boxes (Aerial)	3	0 / Continuous	1		
X	utadrd	JunctBoxA_ep	Junction Boxes (Aerial) (Existing)	3	1 / DGN1	0		
	utadrd	LeaderLine_dp	Leader Line and Terminator with Text	0	0 / Continuous	1		
	utadrd	LiteCond_ep	Street Lighting Conductors (Existing)	3	SG-Conduit-Existing	0	L	SLC
X	utadrd	LoadCenter	Load Center	2	0 / Continuous	1		
X	utadrd	LoadCenter_ep	Load Center (Existing)	2	5 / DGN5	0		
	utadrd	Logo_dp	Consultant Engineer of Record Logo	0	0 / Continuous	1		
X	utadrd	LoopLI_ep	Loop Lead-In (Existing)	3	2 / DGN2	0		
X	utadrd	Loops_ep	Loop Assembly (All Types) (Existing)	2	2 / DGN2	2		
X	utadrd	Luminaire	Luminaires (Decorative - All Types)	2	0 / Continuous	1		
	utadrd	Luminaire_ep	Street Light / Pole (Existing)	3	1 / DGN1	1	P	LP
X	utadrd	Manhole_ex	Manhole on Cross Sections (Existing)	10	3 / DGN3	2		
X	utadrd	Manhole_px	Manhole on Cross Sections	10	0 / Continuous	2		
	utadrd	ManholeCOMM	Manhole (Communications)	6	0 / Continuous	1		
	utadrd	ManholeCOMM_ep	Manhole (Communications) (Existing)	6	1 / DGN1	1	P	MHCATV
X	utadrd	ManholeElec	Manhole (Electric)	3	0 / Continuous	2		
	utadrd	ManholeElec_ep	Manhole (Electric) (Existing)	3	1 / DGN1	1	P	MHE
X	utadrd	ManholeGas	Manhole (Gas)	4	0 / Continuous	2		
	utadrd	ManholeGas_ep	Manhole (Gas) (Existing)	4	1 / DGN1	1	P	MHG
X	utadrd	ManholeSS	Manhole (Sanitary Sewer)	2	0 / Continuous	2		
	utadrd	ManholeSS_ep	Manhole (Sanitary Sewer) (Existing)	2	1 / DGN1	1	P	MHS
X	utadrd	ManholeSW	Manhole (Storm Water)	10	0 / Continuous	2		
	utadrd	ManholeSW_ep	Manhole (Storm Water) (Existing)	10	1 / DGN1	1	P	MHD
X	utadrd	ManholeTel	Manhole (Telephone)	6	0 / Continuous	2		
	utadrd	ManholeTel_ep	Manhole (Telephone) (Existing)	6	1 / DGN1	1	P	MHT
X	utadrd	ManholeUnknown	Manhole (Unknown)	0	0 / Continuous	2		
	utadrd	ManholeUnknown_ep	Manhole (Unknown) (Existing)	0	1 / DGN1	1	P	MH
	utadrd	ManholeWater	Manhole (Water)	1	0 / Continuous	1		
	utadrd	ManholeWater_ep	Manhole (Water) (Existing)	1	1 / DGN1	1	P	MHW
	utadrd	MatchLines_dp	Match Lines with Text, Arrows for Station Notations	1	0 / Continuous	2		

Critical	Rule File	Level Name	Level Description	ByLevel Color	ByLevel Style	ByLevel Weight	Point /Line	Feature Code
X	utadr	MeterElec	Meter (Electric)	3	0 / Continuous	2		
	utadr	MeterElec_ep	Meter (Electric) (Existing)	3	1 / DGN1	1		
	utadr	MeterElecBur_ep	Meter (Electric) (Buried) (Existing)	3	1 / DGN1	1		
X	utadr	MeterGas	Meter (Gas)	4	0 / Continuous	2		
	utadr	MeterGas_ep	Meter (Gas) (Existing)	4	1 / DGN1	1		
	utadr	MeterUnk	Meter (Unknown)	0	0 / Continuous	2		
	utadr	MeterUnk_ep	Meter (Unknown) (Existing)	0	1 / DGN1	1		
X	utadr	MeterWater	Water Meter	1	0 / Continuous	2		
	utadr	MeterWater_ep	Meter (Water) (Existing)	1	1 / DGN1	1		
	utadr	Miscellaneous0	Undefined Proposed Item - Color Blue Weight 0	1	0 / Continuous	0		
	utadr	Miscellaneous1	Undefined Proposed Item - Color Blue Weight 1	1	0 / Continuous	1		
	utadr	Miscellaneous2	Undefined Proposed Item - Color Blue Weight 2	1	0 / Continuous	2		
	utadr	Miscellaneous3	Undefined Proposed Item - Color Green Weight 0	2	0 / Continuous	0		
	utadr	Miscellaneous4	Undefined Proposed Item - Color Green Weight 1	2	0 / Continuous	1		
	utadr	Miscellaneous5	Undefined Proposed Item - Color Green Weight 2	2	0 / Continuous	2		
	utadr	Miscellaneous6	Undefined Proposed Item - Color Red Weight 0	3	0 / Continuous	0		
	utadr	Miscellaneous7	Undefined Proposed Item - Color Red Weight 1	3	0 / Continuous	1		
	utadr	Miscellaneous8	Undefined Proposed Item - Color Red Weight 2	3	0 / Continuous	2		
	utadr	Miscellaneous9	Undefined Proposed Item - Color Red Weight 3	3	0 / Continuous	3		
	utadr	NonPlottingEle_dp	Non-Plotting Items - Construction Elements, Type 66 Elements, Etc.	4	0 / Continuous	0		
	utadr	NorthArw_dp	North Arrows	0	0 / Continuous	2		
X	utadr	Oil	Oil Pipeline, Petroleum	4	UT-Petroleum-Proposed	2		
	utadr	Oil_B_ep	Oil Line (all sizes) Quality Level B Locate (Existing)	4	UT-Petroleum-Existing(B)	1		
	utadr	Oil_C_ep	Oil Line (all sizes) Quality Level C Locate (Existing)	4	UT-Petroleum-Existing(C)	1		
	utadr	Oil_D_ep	Oil Line (all sizes) Quality Level D Locate (Existing)	4	UT-Petroleum-Existing(D)	1		
X	utadr	OverheadSign_ep	Overhead Sign Panels (Existing)	0	3 / DGN3	1		
X	utadr	OverheadStr_ep	Mast Arm, Truss Assemblies, Signal Arms and Supports (Existing)	0	3 / DGN3	1		
	utadr	Patternlines_ep	Cross Section Chain (Existing)	2	1 / DGN1	0	L	XSC
	utadr	PayItem_dp	Pay Item Number Label Elements	4	0 / Continuous	2		
X	utadr	Pedestal_ep	Pedestal (Existing)	1	2 / DGN2	1		
X	utadr	PedHead_ep	Pedestrian Head (All Types) (Existing)	0	2 / DGN2	1		
	utadr	PedSignal_ep	Pedestrian Signal Unit, Signage (Existing)	0	2 / DGN2	0	P	PS
	utadr	PipeEncaseB_ep	Pipe Encasements Quality Level B Locate (Existing)	0	UT-Casing-Existing(B)	1		
	utadr	PipeEncaseC_ep	Pipe Encasements Quality Level C Locate (Existing)	0	UT-Casing-Existing(C)	1		
	utadr	PipeEncaseD_ep	Pipe Encasements Quality Level D Locate (Existing)	0	UT-Casing-Existing(D)	1		
X	utadr	PlotBorder_dp	Plot Border	3	0 / Continuous	0		
	utadr	PointLocator_ep	Point Locator Symbol (Existing)	4	0 / Continuous	0	P	
X	utadr	PoleConc	Concrete Strain Pole	0	0 / Continuous	2		
X	utadr	PoleConc_ep	Concrete Strain Pole (Existing)	0	2 / DGN2	1		
X	utadr	PoleElec	Electrical Pole w/ Transformer	3	0 / Continuous	2		
	utadr	PoleElec_ep	Electrical Pole With or Without Transformer, Shared Pole (Existing)	3	1 / DGN1	1		
X	utadr	PoleFound	Pole Foundation	0	0 / Continuous	2		
X	utadr	PoleLight	Light Pole	2	0 / Continuous	1		
X	utadr	PoleLight_ep	Light Pole (Existing)	2	2 / DGN2	1		
X	utadr	PoleLightHM	High Mast Light Pole	3	0 / Continuous	1		
X	utadr	PoleLightHM_ep	High Mast Light Pole (Existing)	2	2 / DGN2	1		

Critical	Rule File	Level Name	Level Description	ByLevel Color	ByLevel Style	ByLevel Weight	Point /Line	Feature Code
	utadrd	PoleLightID	Light Pole Location / ID	4	0 / Continuous	1		
X	utadrd	PoleShared	Power Pole Electric (Above Ground) Shared w/ Transformer	3	0 / Continuous	2		
X	utadrd	PoleSteelStrain	Steel Strain Pole	0	0 / Continuous	2		
X	utadrd	PoleSteelStrain_ep	Steel Strain Pole (Existing)	0	2 / DGN2	1		
X	utadrd	PoleTel	Telephone Pole	6	0 / Continuous	2		
	utadrd	PoleTel_ep	Telephone Pole (Existing)	6	1 / DGN1	1	P	TELP
X	utadrd	PoleUtil	Utility Pole	0	0 / Continuous	2		
X	utadrd	PoleWoodStrain	Wood Strain Pole	0	0 / Continuous	2		
X	utadrd	PoleWoodStrain_ep	Wood Strain Pole (Existing)	0	2 / DGN2	1		
X	utadrd	PullBox	Pull Boxes (All Types)	3	0 / Continuous	1		
	utadrd	PullBox_ep	Wiring Pull Box (Existing)	3	1 / DGN1	1	P	WPB
	utadrd	Pump	Pump (Petroleum / Fuel)	7	0 / Continuous	2	P	PMPF
X	utadrd	PumpNonPet	Pump (Non Petroleum)	1	0 / Continuous	2		
	utadrd	PumpNonPet_ep	Pump (Non Petroleum) (Existing)	1	1 / DGN1	1	P	PMP
	utadrd	ReferencePt_dp	Survey and Construction Reference Point Details and Elements	4	0 / Continuous	2		
X	utadrd	SanitaryFM	Force Main Lines	2	UT-Sanitary-Proposed	2		
	utadrd	SanitaryFM_B_ep	Force Main (all sizes) Quality Level B Locate (Existing)	2	UT-Sanitary-Existing(B)	1		
	utadrd	SanitaryFM_C_ep	Force Main (All Sizes) Quality Level C Locate (Existing)	2	UT-Sanitary-Existing(C)	1		
	utadrd	SanitaryFM_D_ep	Force Main (All Sizes) Quality Level D Locate (Existing)	2	UT-Sanitary-Existing(D)	1		
X	utadrd	SanitarySewer	Sanitary Sewer	2	UT-Sanitary-Proposed	2		
	utadrd	SanitarySewerB_ep	Sanitary Sewer (All Sizes) Quality Level B Locate (Existing)	2	UT-Sanitary-Existing(B)	1		
	utadrd	SanitarySewerC_ep	Sanitary Sewer (All Sizes) Quality Level C Locate (Existing)	2	UT-Sanitary-Existing(C)	1		
	utadrd	SanitarySewerD_ep	Sanitary Sewer (All Sizes) Quality Level D Locate (Existing)	2	UT-Sanitary-Existing(D)	1		
	utadrd	SanitarySewerDSta	Sewer Sewer Dump Station	2	00 / Continuous	2		
	utadrd	SanitarySewerDSta_ep	Dump Station (SS) (Existing)	2	2 / DGN2	1	P	DMPS
X	utadrd	SanitarySewerEff	Sanitary Sewer Effluent NPW	5	UT-NonPotableWater-Proposed	2		
X	utadrd	SanitarySewerEff_ex	Sanitary Effluent on Cross Sections (Existing)	5	0 / Continuous	0		
X	utadrd	SanitarySewerEff_px	Sanitary Effluent on Cross Sections	5	0 / Continuous	0		
	utadrd	SanitarySewerMisc	Sewer Items (Miscellaneous)	2	0 / Continuous	2		
	utadrd	SanitarySewerMisc_ep	Cleanout, Sanitary Effluent (Open Channel), Pump Station (Existing)	2	1 / DGN1	1		
	utadrd	SateDish_ep	Satellite Dish Antenna (Existing)	6	4 / DGN4	1	P	SATD
	utadrd	Scale_dp	Bar Scale, Scale Label Elements	0	0 / Continuous	2		
	utadrd	Scratch1_dp	Scratch Level for Temporary or Informational Items	4	0 / Continuous	0		
	utadrd	Scratch2_dp	Scratch Level for Temporary or Informational Items	5	0 / Continuous	0		
	utadrd	ScratchEle_dp	Scratch Level for Draft Elements, Temporary Elements, Etc. (DO NOT PLOT)	3	0 / Continuous	0		
	utadrd	ScratchEle2_dp	Scratch Level for Draft Elements, Temporary Elements, Etc. (DO NOT PLOT)	4	0 / Continuous	0		
	utadrd	SheetBorder_dp	Sheet Border	1	0 / Continuous	4		
	utadrd	SheetLines_dp	Sheet Lines	1	0 / Continuous	2		
	utadrd	SheetLinesMisc1_dp	Sheet Lines	1	0 / Continuous	0		
	utadrd	SheetLinesMisc2_dp	Sheet Lines	2	0 / Continuous	2		
	utadrd	SheetLinesMisc3_dp	Sheet Lines	3	0 / Continuous	2		
	utadrd	SheetLinesMisc4_dp	Sheet Lines	4	0 / Continuous	2		
	utadrd	Signal_ep	Signal Head, Signal on Pedestal (Existing)	3	1 / DGN1	1		
X	utadrd	SignalHead_ep	Signal Head Section Details (Existing)	2	2 / DGN2	0		
	utadrd	SignalLoop_ep	Traffic Detector Loops (Existing)	7	1 / DGN1	2	L	TFD
	utadrd	SignalMisc_ep	Signal Equipment Including Control Unit (Miscellaneous) (Existing)	3	2 / DGN2	0	P	SIGC

Critical	Rule File	Level Name	Level Description	ByLevel Color	ByLevel Style	ByLevel Weight	Point /Line	Feature Code
	utadr	SignalSupport_ep	Signal Supports Including Mast Arm (Existing)	3	2 / DGN2	0	P	SMA
X	utadr	SignalSym_ep	Signal Head Symbols (Existing)	3	2 / DGN2	0		
X	utadr	SignCantilever_ep	Sign Symbol Cantilever (Existing)	0	2 / DGN2	0		
	utadr	SignMulti_ep	Multi-column Sign (All Signs) (Existing)	0	3 / DGN3	1		
X	utadr	SignPanel_ep	Sign Panel Elements (Existing)	0	2 / DGN2	1		
	utadr	SignSingle_ep	Sign (Single Support) (Existing)	3	2 / DGN2	0	P	SSS
X	utadr	SignSpanwire	Span Wire Signing Assembly	2	0 / Continuous	1		
X	utadr	SignSpanwire_ep	Span Wire Signing Assembly (Existing)	2	2 / DGN2	1		
	utadr	SignSupport_ep	Trusses and Cantilevers for Overhead Signs (Existing)	0	3 / DGN3	1	L	SGNT
X	utadr	SignTruss_ep	Sign Symbol Truss (Existing)	3	2 / DGN2	1		
	utadr	SpanWire_ep	Signal / Span Wire Pole (Existing)	3	2 / DGN2	0		
X	utadr	Sprinkler	Sprinkler Head	1	0 / Continuous	2		
	utadr	Sprinkler_ep	Sprinkler Head (Existing)	1	1 / DGN1	1	P	SPH
X	utadr	Steam	Steam Pipes	1	UT-Steam-Proposed	2		
	utadr	SteamB_ep	Steam Line Quality Level B Locate (Existing)	4	UT-Steam-Existing(B)	1		
	utadr	SteamC_ep	Steam Line Quality Level C Locate (Existing)	4	UT-Steam-Existing(C)	1		
	utadr	SteamD_ep	Steam Line Quality Level D Locate (Existing)	4	UT-Steam-Existing(D)	1		
X	utadr	StreetLights	Street Lights	2	0 / Continuous	1		
	utadr	SU_QLB_ep	Subsurface Utility Quality Level B Locate Point (Existing)	0	0 / Continuous	1		
	utadr	SU_QLC_ep	Subsurface Utility Quality Level C Locate Point (Existing)	0	0 / Continuous	1		
	utadr	SU_QLD_ep	Subsurface Utility Quality Level D Locate Point (Existing)	0	0 / Continuous	1		
	utadr	SumBoxBorder_dp	Summary Boxes Borders	4	0 / Continuous	3		
	utadr	SumBoxLines_dp	Summary Boxes Lines and Miscellaneous Items	4	0 / Continuous	1		
	utadr	SumBoxLinesMin_dp	Summary Boxes Lines Minor Line and Miscellaneous Items	4	0 / Continuous	0		
X	utadr	Switchgear	Switchgear and Appurtenances	3	0 / Continuous	2		
	utadr	Tables_dp	Data Tables and All Autodesk Tables	0	0 / Continuous	1		
X	utadr	TeleAer	Telephone (Aerial)	6	UT-OverheadTel-Proposed	2		
	utadr	TeleAer_ep	Telephone Line (Aerial) (Existing)	6	UT-OverheadTel-Existing	1	L	TEL
X	utadr	TeleBur	Telephone (Buried)	6	UT-BuriedTel-Proposed	2		
X	utadr	TeleBur_px	Telephone on Cross Sections (Buried) (Miscellaneous)	6	0 / Continuous	1		
	utadr	TeleBurB_ep	Telephone (All Sizes) Quality Level B Locate (Buried) (Existing)	6	UT-BuriedTel-Existing(B)	1		
	utadr	TeleBurC_ep	Telephone (All Sizes) Quality Level C Locate (Buried) (Existing)	6	UT-BuriedTel-Existing(C)	1		
	utadr	TeleBurD_ep	Telephone (All Sizes) Quality Level D Locate (Buried) (Existing)	6	UT-BuriedTel-Existing(D)	1		
	utadr	TeleMisc	Telephone Service Box, Booth or Pedestal	6	0 / Continuous	2		
	utadr	TeleMisc_ep	Telephone Service Box, Booth or Pedestal (Existing)	6	1 / DGN1	1		
	utadr	TextBLStation	Text - B/L Station and Tics	0	0 / Continuous	2		
	utadr	TextConstEle	Text - Construction Element	0	0 / Continuous	1		
	utadr	TextCurveData	Text - Curve Data Note	0	0 / Continuous	2		
	utadr	TextDetails	Text - Detail Notes	4	0 / Continuous	2		
	utadr	TextDrainInvElev_ep	Text - Drainage Invert Elevation (Existing)	0	0 / Continuous	1		
	utadr	TextDrainLabel_ep	Text - Drainage (Existing)	0	0 / Continuous	1		
	utadr	TextElevLabel	Text - Elevation Labels	4	0 / Continuous	0		
	utadr	TextLabel	Text - Label	0	0 / Continuous	2		
	utadr	TextLandscape	Text - Landscape Labels	0	0 / Continuous	1		
	utadr	TextMajor	Text - Major	0	0 / Continuous	5		
	utadr	TextMinor	Text - Minor	0	0 / Continuous	0		

Critical	Rule File	Level Name	Level Description	ByLevel Color	ByLevel Style	ByLevel Weight	Point /Line	Feature Code
	utadr	TextMisc	Text - Miscellaneous	0	0 / Continuous	1		
	utadr	TextNotes	Text - Notes	4	0 / Continuous	1		
	utadr	TextProfLabel	Text - Profile, Horizontal and Vertical Axis Labels	0	0 / Continuous	2		
	utadr	TextProjLabel	Text - Begin and End Project Label with Leader Lines	1	0 / Continuous	2		
	utadr	TextPtLabel	Text - Point Labels	4	0 / Continuous	0		
	utadr	TextShtNo	Text - Sheet Number	0	0 / Continuous	2		
	utadr	TextSubUtilLabel_ep	Text - Subsurface Utilities (Existing)	0	0 / Continuous	1		
	utadr	TextSurveyLabel	Text - Survey Labels	0	0 / Continuous	0		
	utadr	TextTables	Text - Key Sheet Indexes and Table Data	4	0 / Continuous	2		
	utadr	TextTitle	Text - Title	0	0 / Continuous	3		
	utadr	TextTopoLabel_ep	Text - Topography (Existing)	0	0 / Continuous	1		
	utadr	TextUtilLabel_ep	Text - Utilities (Existing)	0	0 / Continuous	1		
	utadr	TextXSElev	Text - Cross Section Elevations	2	0 / Continuous	1		
	utadr	TopoMisc_ep	Topography (Miscellaneous) (Existing)	0	3 / DGN3	1	L	MISC
X	utadr	Tower	High Mast Light Poles or Towers, Transmission Tower, Antenna	3	0 / Continuous	2		
	utadr	Tower_ep	High Mast Light Poles or Towers, Transmission Tower, Antenna (Existing)	3	1 / DGN1	1		
X	utadr	TransformerAer	Transformer (Above Ground)	3	0 / Continuous	2		
X	utadr	TransformerBur	Transformer (Buried)	3	0 / Continuous	2		
X	utadr	TransmissionAer	Electric Conductors (Distribution & Transmission) (Aerial)	3	UT-OverheadElec-Proposed	2		
X	utadr	TransmissionBur	Electric Conductors (Distribution & Transmission) (Buried)	3	UT-BuriedElec-Proposed	2		
X	utadr	TransmissionT	Transmission Tower Single	3	0 / Continuous	2		
	utadr	UtilMisc_ep	Utility Items (Miscellaneous) (Existing)	0	0 / Continuous	0		
	utadr	UtilsMisc	Utility Items (Miscellaneous)	8	0 / Continuous	2		
X	utadr	UtilsProposed	Facilities/Utilities as shown in Utility Adjustments	9	0 / Continuous	2		
X	utadr	Valve	Valve, Valve Box (Unknown)	0	0 / Continuous	2		
	utadr	Valve_ep	Valve, Valve Box (Existing)	0	1 / DGN1	1		
X	utadr	ValveCover	Valve Cover (Unknown)	0	0 / Continuous	2		
	utadr	ValveCover_ep	Valve Cover (Unknown) (Existing)	0	1 / DGN1	1	P	VC
X	utadr	ValveCvrEff	Valve Cover (Effluent)	5	0 / Continuous	2		
	utadr	ValveCvrEff_ep	Valve Cover (Effluent) (Existing)	5	1 / DGN1	1	P	VCEF
X	utadr	ValveCvrGas	Valve Cover (Gas)	4	0 / Continuous	2		
	utadr	ValveCvrGas_ep	Valve Cover (Gas) (Existing)	4	1 / DGN1	1	P	VCG
X	utadr	ValveCvrSewer	Valve Cover (Sewer)	2	0 / Continuous	2		
	utadr	ValveCvrSewer_ep	Valve Cover (Sewer) (Existing)	2	1 / DGN1	1	P	VCS
X	utadr	ValveCvrWater	Valve Cover (Water)	1	0 / Continuous	2		
	utadr	ValveCvrWater_ep	Valve Cover (Water) (Existing)	1	1 / DGN1	1	P	VCW
X	utadr	ValveCvrWaterNP	Water Line Non Potable	5	0 / Continuous	2		
	utadr	ValveCvrWaterNP_ep	Valve Cover (Non-potable Water) (Existing)	5	1 / DGN1	1		
X	utadr	ValveGas	Valve, Valve Box (Gas)	4	0 / Continuous	2		
	utadr	ValveGas_ep	Valve (Gas), Valve Box (Existing)	4	1 / DGN1	1		
X	utadr	ValveSewer	Valve, Valve Box (Sewer)	2	0 / Continuous	2		
	utadr	ValveSewer_ep	Valve (Sewer), Valve Box (Existing)	2	1 / DGN1	1		
X	utadr	ValveWater	Valve, Valve Box (Water)	1	0 / Continuous	2		
	utadr	ValveWater_ep	Valve (Water), Valve Box (Existing)	1	1 / DGN1	1		
X	utadr	ValveWaterNP	Water Line (Non Potable)	5	0 / Continuous	2		
	utadr	ValveWaterNP_ep	Valve (Non-potable Water), Valve Box (Existing)	8	1 / DGN1	1		

Critical	Rule File	Level Name	Level Description	ByLevel Color	ByLevel Style	ByLevel Weight	Point /Line	Feature Code
	utadr	Vault_ep	Vaults Above Grade and Below Grade (Existing)	3	1 / DGN1	0		
X	utadr	Vaults	Vaults Above Grade and Below Grade	3	0 / Continuous	2		
X	utadr	VaultsRW	Vaults (Raw Water)	1	0 / Continuous	2		
	utadr	Vent	Vent (Unknown) PROPOSED UNKNOW VENT	0	0 / Continuous	2		
	utadr	Vent_ep	Vent (Existing)	0	1 / DGN1	1	P	VNT
X	utadr	VentGas	Vent (Gas)	4	0 / Continuous	2		
	utadr	VentGas_ep	Vent (Gas) (Existing)	4	1 / DGN1	1	P	VNTG
X	utadr	VentSewer	Vent (Sewer)	2	0 / Continuous	2		
	utadr	VentSewer_ep	Vent (Sewer) (Existing)	2	1 / DGN1	1	P	VNTS
	utadr	Viewport	Viewport (For AutoCAD Use)	3	0 / Continuous	0		
X	utadr	Water	Water Line	1	UT-Water-Proposed	2		
	utadr	WaterB_ep	Water Line (All Sizes) Quality Level B Locate (Existing)	1	UT-Water-Existing(B)	1		
	utadr	WaterC_ep	Water Line (All Sizes) Quality Level C Locate (Existing)	1	UT-Water-Existing(C)	1		
	utadr	WaterD_ep	Water Line (All Sizes) Quality Level D Locate (Existing)	1	UT-Water-Existing(D)	1		
X	utadr	WaterFct	Standpipe and Water Faucet	1	0 / Continuous	2		
X	utadr	WaterFilter	Water Filter	5	0 / Continuous	2		
	utadr	WaterMisc_ep	Faucet, Standpipe (Existing)	1	1 / DGN1	1		
X	utadr	WaterNP	Water Line (Non Potable)	5	UT-NonPotableWater-Proposed	2		
	utadr	WaterNP_B_ep	Non-potable Water Line (All Sizes) Quality Level B Locate (Existing)	5	UT-NonPotableWater-Existing(B)	1		
	utadr	WaterNP_C_ep	Non-potable Water Line (All Sizes) Quality Level C Locate (Existing)	5	UT-NonPotableWater-Existing(C)	1		
	utadr	WaterNP_D_ep	Non-potable Water Line (All Sizes) Quality Level D Locate (Existing)	5	UT-NonPotableWater-Existing(D)	1		
X	utadr	WaterNP_ex	Raw Water Pipes on Cross Sections (Existing)	5	0 / Continuous	1		
X	utadr	WaterNP_px	Raw Water Pipes on Cross Sections	5	0 / Continuous	1		
X	utadr	Well	Well (Any Size)	1	1 / DGN1	2		
	utadr	Well_ep	Well (Any Size) (Existing)	1	1 / DGN1	1		
X	utadr	WellMon	Well MonitoringMonitoring Well	1	0 / Continuous	2		
	utadr	WellMon_ep	Well Monitoring, Taps (Existing)	1	1 / DGN1	1	P	MONW
	utadr	Xreference01_dp	Reference Files (For AutoCAD Use)	0	0 / Continuous	1		
	utadr	Xreference02_dp	Reference Files (For AutoCAD Use)	0	0 / Continuous	1		
	utadr	Xreference03_dp	Reference Files (For AutoCAD Use)	0	0 / Continuous	1		
	utadr	Xreference04_dp	Reference Files (For AutoCAD Use)	0	0 / Continuous	1		
	utadr	XSCell	GEOPAK Cross Section Cell/Block and Profile Cell/Block	8	0 / Continuous	1		



## UTEXRD - Utilities Existing

Critical	Rule File	Level Name	Level Description	ByLevel Color	ByLevelStyle / Linetype	ByLevel Weight	Point / Line	Feature Code
	utexrd	Beacons_ep	Beacons and Path Illumination (Existing)	0	0 / Continuous	1	p	BN
	utexrd	CATVAer_ep	Cable TV Line (Aerial) (Existing)	6	UT-OverheadCable-Existing	1	L	CATV
	utexrd	CATVBurB_ep	Cable TV Line Quality Level B Locate (Buried) (Existing)	6	UT-BuriedCable-Existing(B)	1	L	BCATVB
	utexrd	CATVBurC_ep	Cable TV Line Quality Level C Locate (Buried) (Existing)	6	UT-BuriedCable-Existing(C)	1	L	BCATVC
	utexrd	CATVBurD_ep	Cable TV Line Quality Level D Locate (Buried) (Existing)	6	UT-BuriedCable-Existing(D)	1	L	BCATVD
	utexrd	CATVCondBurB_ep	Cable TV Conduit System Quality Level B Locate (Buried) (Existing)	6	UT-BuriedCable-Existing(B)	1	L	CATVCB
	utexrd	CATVCondBurC_ep	Cable TV Conduit System Quality Level C Locate (Buried) (Existing)	6	UT-BuriedCable-Existing(C)	1	L	CATVCC
	utexrd	CATVCondBurD_ep	Cable TV Conduit System Quality Level D Locate (Buried) (Existing)	6	UT-BuriedCable-Existing(D)	1	L	CATVCD
	utexrd	CATVMisc_ep	Cable TV Service Box and Miscellaneous, Pole (Existing)	6	1 / DGN1	1	P	CATVS
	utexrd	ConduitB_ep	Utility Conduit & Encasements Quality Level B Locate (Existing)	3	UT-Casing-Existing(B)	1	L	DUCTB
	utexrd	ConduitC_ep	Utility Conduit & Encasements Quality Level C Locate (Existing)	3	UT-Casing-Existing(C)	1	L	DUCTC
	utexrd	ConduitD_ep	Utility Conduit & Encasements Quality Level D Locate (Existing)	3	UT-Casing-Existing(D)	1	L	DUCTD
	utexrd	ConstLines	Construction Lines and References	1	0 / Continuous	0		
	utexrd	ConstLines_pm	Construction Lines	4	0 / Continuous	0		
	utexrd	ElecAer_ep	High Voltage Transmission Line (Existing)	3	UT-OverheadElec-Existing	1	L	HVL
	utexrd	ElecAer_ep	Electrical Lines (Aerial) (Existing)	3	UT-OverheadElec-Existing	1	L	PWR
	utexrd	ElecAerPri_ep	Conductors (Primary Distribution) (Aerial) (Existing)	3	UT-OverheadElec-Existing	1	L	PRI
	utexrd	ElecAerSec_ep	Conductors (Secondary Distribution) (Aerial) (Existing)	3	UT-OverheadElec-Existing	1	L	SEC
	utexrd	ElecBurB_ep	Electrical Quality Level B Locate (Buried) (Existing)	3	UT-BuriedElec-Existing(B)	1	L	BPWRB
	utexrd	ElecBurC_ep	Electrical Quality Level C Locate (Buried) (Existing)	3	UT-BuriedElec-Existing(C)	1	L	BPWRC
	utexrd	ElecBurCap_ep	Capacitors (Buried) (Existing)	3	1 / DGN1	1	L	CAPB
	utexrd	ElecBurD_ep	Electrical Quality Level D Locate (Buried) (Existing)	3	UT-BuriedElec-Existing(D)	1	L	BPWRD
	utexrd	ElecBurPriB_ep	Conductors (Primary Distribution) Quality Level B Locate (Buried) (Existing)	3	UT-BuriedElec-Existing(B)	1	L	TRANSB
	utexrd	ElecBurPriC_ep	Conductors (Primary Distribution) Quality Level C Locate (Buried) (Existing)	3	UT-BuriedElec-Existing(C)	1	L	TRANSC
	utexrd	ElecBurPriD_ep	Conductors (Primary Distribution) Quality Level D Locate (Buried) (Existing)	3	UT-BuriedElec-Existing(D)	1	L	TRANSD
	utexrd	ElecBurSecB_ep	Conductor (Secondary Distribution) Quality Level B Locate (Buried) (Existing)	3	UT-BuriedElec-Existing(B)	1	L	BSECB
	utexrd	ElecBurSecC_ep	Conductor (Secondary Distribution) Quality Level C Locate (Buried) (Existing)	3	UT-BuriedElec-Existing(C)	1	L	BSECC
	utexrd	ElecBurSecD_ep	Conductor (Secondary Distribution) Quality Level D Locate (Buried) (Existing)	3	UT-BuriedElec-Existing(D)	1	L	BSECD
	utexrd	ElecMisc_ep	Capacitors (Above Ground) (Existing)	3	1 / DGN1	1	L	CAPA
	utexrd	ElecMisc_ep	Electric Service Box (Large) (Existing)	3	1 / DGN1	1	L	ELECS
	utexrd	ElecMisc_ep	Fuses (Existing) (Existing)	3	1 / DGN1	1	L	FUSE
	utexrd	ElecMisc_ep	Switchgear & Appurtenances (Existing)	3	1 / DGN1	1	L	SW
	utexrd	ElecMisc_ep	Transformer (Existing)	3	1 / DGN1	1	P	TRNF
	utexrd	ElecOutlet_ep	Electrical Outlet (Existing)	3	1 / DGN1	1	P	ELEO
	utexrd	FireHydrant_ep	Fire Hydrant (Existing)	1	1 / DGN1	1	P	FH
	utexrd	FloodLight_ep	Flood Light (Existing)	3	1 / DGN1	1	P	FLD
	utexrd	FOCAer_ep	Fiber Optics Cable (Aerial) (Existing)	6	UT-OverheadFOC-Existing	1	L	FOC
	utexrd	FOCBurB_ep	Fiber Optics Cable Quality Level B Locate (Buried) (Existing)	6	UT-BuriedFOC(B)-Existing	1	L	FOCUB
	utexrd	FOCBurB_ep	Fiber Optics Cable Quality Level B Locate (Buried) (Existing)	6	UT-BuriedFOC(B)-Existing	1	L	FOTVUB
	utexrd	FOCBurB_ep	Fiber Optics Cable Quality Level B Locate (Buried) (Existing)	6	UT-BuriedFOC(B)-Existing	1	L	FOUB
	utexrd	FOCBurC_ep	Fiber Optics Cable Quality Level C Locate (Buried) (Existing)	6	UT-BuriedFOC(C)-Existing	1	L	FOCUC
	utexrd	FOCBurC_ep	Fiber Optics Cable Quality Level C Locate (Buried) (Existing)	6	UT-BuriedFOC(C)-Existing	1	L	FOTVUC
	utexrd	FOCBurC_ep	Fiber Optics Cable Quality Level C Locate (Buried) (Existing)	6	UT-BuriedFOC(C)-Existing	1	L	FOUC
	utexrd	FOCBurD_ep	Fiber Optics Cable Quality Level D Locate (Buried) (Existing)	6	UT-BuriedFOC(D)-Existing	1	L	FOCUD

Critical	Rule File	Level Name	Level Description	ByLevel Color	ByLevelStyle / Linetype	ByLevel Weight	Point /Line	Feature Code
	utexrd	FOCBurD_ep	Fiber Optics Cable Quality Level D Locate (Buried) (Existing)	6	UT-BuriedFOC(D)-Existing	1	L	FOTVUD
	utexrd	FOCBurD_ep	Fiber Optics Cable Quality Level D Locate (Buried) (Existing)	6	UT-BuriedFOC(D)-Existing	1	L	FOUD
	utexrd	FOEElecAer_ep	Fiber Optics Electrical (Aerial) (Existing)	3	UT-OverheadFOE-Existing	1	L	FOP
	utexrd	FOEElecBurB_ep	Fiber Optics Electrical Quality Level B Locate (Buried) (Existing)	3	UT-BuriedFOE(B)-Existing	1	L	FOPUB
	utexrd	FOEElecBurC_ep	Fiber Optics Electrical Quality Level C Locate (Buried) (Existing)	3	UT-BuriedFOE(C)-Existing	1	L	FOPUC
	utexrd	FOEElecBurD_ep	Fiber Optics Electrical Quality Level D Locate (Buried) (Existing)	3	UT-BuriedFOE(D)-Existing	1	L	FOPUD
	utexrd	FOTAer_ep	Fiber Optics Telephone (Aerial) (Size Unknown) (Existing)	6	UT-OverheadFOT-Existing	1	L	FO
	utexrd	FOTBurB_ep	Fiber Optics Telephone Quality Level B Locate (Buried) (Size Unknown) (Existing)	6	UT-BuriedFOT(B)-Existing	1	L	FOB
	utexrd	FOTBurC_ep	Fiber Optics Telephone Quality Level C Locate (Buried) (Size Unknown) (Existing)	6	UT-BuriedFOT(C)-Existing	1	L	FOC
	utexrd	FOTBurD_ep	Fiber Optics Telephone Quality Level D Locate (Buried) (Size Unknown) (Existing)	6	UT-BuriedFOT(D)-Existing	1	L	FOD
	utexrd	Gas_ep	Gas Test & Miscellaneous (Existing)	4	1 / DGN1	1	L	GTM
	utexrd	GasB_ep	Gas Line (All Sizes) Quality Level B Locate (Existing)	4	UT-Gas-Existing(B)	1	L	GASB
	utexrd	GasC_ep	Gas Line (All Sizes) Quality Level C Locate (Existing)	4	UT-Gas-Existing(C)	1	L	GASC
	utexrd	GasD_ep	Gas Line (All Sizes) Quality Level D Locate (Existing)	4	UT-Gas-Existing(D)	1	L	GASD
	utexrd	GasReg_ep	Gas Regulator (Existing)	4	1 / DGN1	1	L	RG
	utexrd	Gauges_ep	Gauges (Existing)	0	1 / DGN1	1	P	GA
	utexrd	GuyWire_ep	Guy Anchor (Existing)	3	1 / DGN1	1	P	GYA
	utexrd	GuyWire_ep	Guy Pole (Deadman) (Existing)	3	1 / DGN1	1	P	GYP
	utexrd	GuyWire_ep	Span Guys (Existing)	3	1 / DGN1	1	L	GYS
	utexrd	ImageAttachment_dp	Image Attachments	0	0 / Continuous	0		
	utexrd	JunctBox_ep	Junction Box / Service Cabinet (Elec/Tel) (Existing)	3	1 / DGN1	1	P	SRVC
	utexrd	LeaderLine_dp	Leader Line and Terminator with Text	0	0 / Continuous	1		
	utexrd	LiteCond_ep	Street Lighting Conductors (Existing)	3	SG-Conduit-Existing	0	L	SLC
	utexrd	Luminaire_ep	Street Light / Pole (Existing)	3	1 / DGN1	1	P	LP
	utexrd	ManholeCOMM_ep	Manhole (Communications) (Existing)	6	1 / DGN1	1	P	MHCATV
	utexrd	ManholeElec_ep	Manhole (Electric) (Existing)	3	1 / DGN1	1	P	MHE
	utexrd	ManholeGas_ep	Manhole (Gas) (Existing)	4	1 / DGN1	1	P	MHG
	utexrd	ManholeSS_ep	Manhole (Sanitary Sewer) (Existing)	2	1 / DGN1	1	P	MHS
	utexrd	ManholeSW_ep	Manhole (Storm Water) (Existing)	10	1 / DGN1	1	P	MHD
	utexrd	ManholeTel_ep	Manhole (Telephone) (Existing)	6	1 / DGN1	1	P	MHT
	utexrd	ManholeUnknown_ep	Manhole (Unknown) (Existing)	0	1 / DGN1	1	P	MH
	utexrd	ManholeWater_ep	Manhole (Water) (Existing)	1	1 / DGN1	1	P	MHW
	utexrd	MeterElec_ep	Meter (Electric) (Existing)	3	1 / DGN1	1	P	ME
	utexrd	MeterElecBur_ep	Meter (Electric) (Buried) (Existing)	3	1 / DGN1	1	P	MEU
	utexrd	MeterGas_ep	Meter (Gas) (Existing)	4	1 / DGN1	1	P	MG
	utexrd	MeterUnk_ep	Meter (Unknown) (Existing)	0	1 / DGN1	1	P	M
	utexrd	MeterWater_ep	Meter (Water) (Existing)	1	1 / DGN1	1	P	MW
	utexrd	Oil_B_ep	Oil Line (All Sizes) Quality Level B Locate (Existing)	4	UT-Petroleum-Existing(B)	1	L	PETROB
	utexrd	Oil_C_ep	Oil Line (All Sizes) Quality Level C Locate (Existing)	4	UT-Petroleum-Existing(C)	1	L	PETROC
	utexrd	Oil_D_ep	Oil Line (All Sizes) Quality Level D Locate (Existing)	4	UT-Petroleum-Existing(D)	1	L	PETROD
	utexrd	PipeEncaseB_ep	Pipe Encasements Quality Level B Locate (Existing)	0	UT-Casing-Existing(B)	1	L	PIPENB
	utexrd	PipeEncaseC_ep	Pipe Encasements Quality Level C Locate (Existing)	0	UT-Casing-Existing(C)	1	L	PIPENC
	utexrd	PipeEncaseD_ep	Pipe Encasements Quality Level D Locate (Existing)	0	UT-Casing-Existing(D)	1	L	PIPEND
	utexrd	PoleElec_ep	Electrical Pole (Existing)	3	1 / DGN1	1	P	PP
	utexrd	PoleElec_ep	Electrical Pole With Transformer (Existing)	3	1 / DGN1	1	P	PPT



Critical	Rule File	Level Name	Level Description	ByLevel Color	ByLevelStyle / Linetype	ByLevel Weight	Point /Line	Feature Code
	utexrd	PoleElec_ep	Shared Pole (Existing)	3	1 / DGN1	1	P	SHP
	utexrd	PoleElec_ep	Shared Pole With Transformer (Existing)	3	1 / DGN1	1	P	SHPT
	utexrd	PoleTel_ep	Telephone Pole (Existing)	6	1 / DGN1	1	P	TELP
	utexrd	PullBox_ep	Wiring Pull Box (Existing)	3	1 / DGN1	1	P	WPB
	utexrd	Pump_ep	Pump (Petroleum / Fuel) (Existing)	7	1 / DGN1	1	P	PMPF
	utexrd	PumpNonPet_ep	Pump (Non Petroleum) (Existing)	1	1 / DGN1	1	P	PMP
	utexrd	SanitaryFM_B_ep	Force Main (All Sizes) Quality Level B Locate (Existing)	2	UT-Sanitary-Existing(B)	1	L	FMB
	utexrd	SanitaryFM_C_ep	Force Main (All Sizes) Quality Level C Locate (Existing)	2	UT-Sanitary-Existing(C)	1	L	FMC
	utexrd	SanitaryFM_D_ep	Force Main (All Sizes) Quality Level D Locate (Existing)	2	UT-Sanitary-Existing(D)	1	L	FMD
	utexrd	SanitarySewerB_ep	Sanitary Sewer (All Sizes) Quality Level B Locate (Existing)	2	UT-Sanitary-Existing(B)	1	L	SSB
	utexrd	SanitarySewerC_ep	Sanitary Sewer (All Sizes) Quality Level C Locate (Existing)	2	UT-Sanitary-Existing(C)	1	L	SSC
	utexrd	SanitarySewerD_ep	Sanitary Sewer (All Sizes) Quality Level D Locate (Existing)	2	UT-Sanitary-Existing(D)	1	L	SSD
	utexrd	SanitarySewerDSta_ep	Dump Station (SS) (Existing)	2	2 / DGN2	1	P	DMPS
	utexrd	SanitarySewerMisc_ep	Cleanout (Existing)	2	1 / DGN1	1	P	CLNO
	utexrd	SanitarySewerMisc_ep	Pump Station (Sanitary Sewer) (Existing)	2	1 / DGN1	1	P	PMPST
	utexrd	SanitarySewerMisc_ep	Sanitary Effluent (Open Channel) (Existing)	2	1 / DGN1	1	L	SE
	utexrd	SateDish_ep	Satellite Dish Antenna (Existing)	6	4 / DGN4	1	P	SATD
	utexrd	Sprinkler_ep	Sprinkler Head (Existing)	1	1 / DGN1	1	P	SPH
	utexrd	SteamB_ep	Steam Line Quality Level B Locate (Existing)	1	UT-Steam-Existing(B)	1	L	STEAMB
	utexrd	SteamC_ep	Steam Line Quality Level C Locate (Existing)	1	UT-Steam-Existing(C)	1	L	STEAMC
	utexrd	SteamD_ep	Steam Line Quality Level D Locate (Existing)	1	UT-Steam-Existing(D)	1	L	STEAMD
	utexrd	SU_Misc_ep	Subsurface Utility (Miscellaneous) (Existing)	0	0 / Continuous	1	P	EOI
	utexrd	SU_Misc_ep	Subsurface Utility (Miscellaneous) (Existing)	0	0 / Continuous	1	P	QDEL
	utexrd	SU_QLA_ep	Subsurface Utility Quality Level A Locate Point (Existing)	0	0 / Continuous	1	P	QLA
	utexrd	SU_QLB_ep	Subsurface Utility Quality Level B Locate Point (Existing)	0	0 / Continuous	1	P	QLB
	utexrd	SU_QLC_ep	Subsurface Utility Quality Level C Locate Point (Existing)	0	0 / Continuous	1	P	QLC
	utexrd	SU_QLD_ep	Subsurface Utility Quality Level D Locate Point (Existing)	0	0 / Continuous	1	P	QLD
	utexrd	SU_TestHole_ep	Subsurface Utility Test Hole (QLA Only) (Existing)	0	0 / Continuous	1	P	THA
	utexrd	Tables_dp	Data Tables and All Autodesk Tables	0	0 / Continuous	1		
	utexrd	TeleAer_ep	Telephone Line (Aerial) (Existing)	6	UT-OverheadTel-Existing	1	L	TEL
	utexrd	TeleBurB_ep	Telephone (All Sizes) Quality Level B Locate (Buried) (Existing)	6	UT-BuriedTel-Existing(B)	1	L	BTB
	utexrd	TeleBurB_ep	Telephone (All Sizes) Quality Level B Locate (Buried) (Existing)	6	UT-BuriedTel-Existing(B)	1	L	BTDB
	utexrd	TeleBurB_ep	Telephone (All Sizes) Quality Level B Locate (Buried) (Existing)	6	UT-BuriedTel-Existing(B)	1	L	BTTB
	utexrd	TeleBurC_ep	Telephone (All Sizes) Quality Level C Locate (Buried) (Existing)	6	UT-BuriedTel-Existing(C)	1	L	BTC
	utexrd	TeleBurC_ep	Telephone (All Sizes) Quality Level C Locate (Buried) (Existing)	6	UT-BuriedTel-Existing(C)	1	L	BTDC
	utexrd	TeleBurC_ep	Telephone (All Sizes) Quality Level C Locate (Buried) (Existing)	6	UT-BuriedTel-Existing(C)	1	L	BTTC
	utexrd	TeleBurD_ep	Telephone (All Sizes) Quality Level D Locate (Buried) (Existing)	6	UT-BuriedTel-Existing(D)	1	L	BTD
	utexrd	TeleBurD_ep	Telephone (All Sizes) Quality Level D Locate (Buried) (Existing)	6	UT-BuriedTel-Existing(D)	1	L	BTDD
	utexrd	TeleBurD_ep	Telephone (All Sizes) Quality Level D Locate (Buried) (Existing)	6	UT-BuriedTel-Existing(D)	1	L	BTTD
	utexrd	TeleMisc_ep	Telephone Booth (Existing)	6	1 / DGN1	1	P	TB
	utexrd	TeleMisc_ep	Telephone Service Box (Large) (Existing)	6	1 / DGN1	1	L	TELS
	utexrd	TeleMisc_ep	Telephone Pedestal / Service (Existing)	6	1 / DGN1	1	P	TPD
	utexrd	TextMisc	Text - Miscellaneous	0	0 / Continuous	1		
	utexrd	TextNotes	Text - Notes	4	0 / Continuous	1		
	utexrd	TextSubUtilLabel_ep	Text - Subsurface Utilities (Existing)	0	0 / Continuous	1		
	utexrd	TextUtilLabel_ep	Text - Utilities (Existing)	0	0 / Continuous	1		

Critical	Rule File	Level Name	Level Description	ByLevel Color	ByLevelStyle / Linetype	ByLevel Weight	Point /Line	Feature Code
	utexrd	Tower_ep	Antenna (Existing)	3	1 / DGN1	1	P	ANT
	utexrd	Tower_ep	Transmission Tower (Single Column) (Existing)	3	1 / DGN1	1	P	CLMT
	utexrd	Tower_ep	High Mast Lighting Poles (Existing)	3	1 / DGN1	1	P	HML
	utexrd	UtilMisc_ep	Utility Items (Miscellaneous) (Existing)	0	0 / Continuous	0		
	utexrd	Valve_ep	Valve Box (Existing)	0	1 / DGN1	1	P	VB
	utexrd	Valve_ep	Valve (Existing)	0	1 / DGN1	1	P	VLV
X	utexrd	ValveBFP_ep	Valve (Back Flow Preventer), Valve Box (Existing)	0	1 / DGN1	1	P	VLVB
	utexrd	ValveCover_ep	Valve Cover (Unknown) (Existing)	0	1 / DGN1	1	P	VC
	utexrd	ValveCvrEff_ep	Valve Cover (Effluent) (Existing)	5	1 / DGN1	1	P	VCEF
	utexrd	ValveCvrGas_ep	Valve Cover (Gas) (Existing)	4	1 / DGN1	1	P	VCG
	utexrd	ValveCvrSewer_ep	Valve Cover (Sewer) (Existing)	2	1 / DGN1	1	P	VCS
	utexrd	ValveCvrWater_ep	Valve Cover (Water) (Existing)	1	1 / DGN1	1	P	VCW
	utexrd	ValveCvrWaterNP_ep	Valve Cover (Non-potable Water) (Existing)	5	1 / DGN1	1	P	VCNPW
	utexrd	ValveCvrWaterNP_ep	Valve Cover (Raw Water) (Existing)	5	1 / DGN1	1	P	VCRW
	utexrd	ValveGas_ep	Valve Box (Gas) (Existing)	4	1 / DGN1	1	P	VBG
	utexrd	ValveGas_ep	Valve (Gas) (Existing)	4	1 / DGN1	1	P	VLVG
	utexrd	ValveSewer_ep	Valve Box (Sewer) (Existing)	2	1 / DGN1	1	P	VBS
	utexrd	ValveSewer_ep	Valve (Sewer) (Existing)	2	1 / DGN1	1	P	VLVS
	utexrd	ValveWater_ep	Valve Box (Water) (Existing)	1	1 / DGN1	1	P	VBW
	utexrd	ValveWater_ep	Valve (Water) (Existing)	1	1 / DGN1	1	P	VLVW
	utexrd	ValveWaterNP_ep	Valve Box (Non-potable Water) (Existing)	5	1 / DGN1	1	P	VBNPW
	utexrd	ValveWaterNP_ep	Valve (Non-potable Water) (Existing)	5	1 / DGN1	1	P	VLVNPW
	utexrd	Vault_ep	Vaults Above Grade (Existing)	3	1 / DGN1	0	L	AGV
	utexrd	Vault_ep	Vaults Below Grade (Existing)	3	1 / DGN1	0	L	BGV
	utexrd	Vent_ep	Vent (Existing)	0	1 / DGN1	1	P	VNT
	utexrd	VentGas_ep	Vent (Gas) (Existing)	4	1 / DGN1	1	P	VNTG
	utexrd	VentSewer_ep	Vent (Sewer) (Existing)	2	1 / DGN1	1	P	VNTS
	utexrd	Viewport	Viewport (For AutoCAD Use)	3	0 / Continuous	0		
	utexrd	WaterB_ep	Water Line (All Sizes) Quality Level B Locate (Existing)	1	UT-Water-Existing(B)	1	L	WLB
	utexrd	WaterC_ep	Water Line (All Sizes) Quality Level C Locate (Existing)	1	UT-Water-Existing(C)	1	L	WLC
	utexrd	WaterD_ep	Water Line (All Sizes) Quality Level D Locate (Existing)	1	UT-Water-Existing(D)	1	L	WLD
	utexrd	WaterMisc_ep	Faucet (Existing)	1	1 / DGN1	1	P	FAU
	utexrd	WaterMisc_ep	Standpipe (Existing)	1	1 / DGN1	1	P	SP
	utexrd	WaterNP_B_ep	Non-potable Water Line (All Sizes) Quality Level B Locate (Existing)	5	UT-NonPotableWater-Existing(B)	1	L	NPWLB
	utexrd	WaterNP_C_ep	Non-potable Water Line (All Sizes) Quality Level C Locate (Existing)	5	UT-NonPotableWater-Existing(C)	1	L	NPWLC
	utexrd	WaterNP_D_ep	Non-potable Water Line (All Sizes) Quality Level D Locate (Existing)	5	UT-NonPotableWater-Existing(D)	1	L	NPWLD
	utexrd	Well_ep	Well (Any Size) (Existing)	1	1 / DGN1	1	P	WELL
	utexrd	WellMon_ep	Well Monitoring, Taps (Existing)	1	1 / DGN1	1	P	MONW
	utexrd	Xreference01_dp	Reference Files (For AutoCAD Use)	0	0 / Continuous	1		
	utexrd	Xreference02_dp	Reference Files (For AutoCAD Use)	0	0 / Continuous	1		
	utexrd	Xreference03_dp	Reference Files (For AutoCAD Use)	0	0 / Continuous	1		
	utexrd	Xreference04_dp	Reference Files (For AutoCAD Use)	0	0 / Continuous	1		

## UTPRRD - Utilities Proposed

Critical	Rule File	Level Name	Level Description	ByLevel Color	ByLevelStyle / Linetype	ByLevel Weight
	utprrd	ActivePointCell_dp	Active Point Cell	4	0 / Continuous	10
	utprrd	AdhocPoint_dp	Adhoc Points Placed by SheetInfo	0	4 / DGN4	0
	utprrd	Beacons_ep	Beacons and Path Illumination (Existing)	0	0 / Continuous	1
X	utprrd	Capacitor	Capacitors (All Types)	3	0 / Continuous	2
	utprrd	Casing	Casing	0	UT-Casing-Proposed	2
X	utprrd	CATVAer	Cable TV Line (Aerial)	6	UT-OverheadCable-Proposed	2
	utprrd	CATVAer_ep	Cable TV Line (Aerial) (Existing)	6	UT-OverheadCable-Existing	1
X	utprrd	CATVBur	Cable TV Line (Buried)	6	UT-BuriedCable-Proposed	2
X	utprrd	CATVBur_px	Cable TV and Miscellaneous on Cross Sections (Buried)	6	0 / Continuous	1
	utprrd	CATVBurB_ep	Cable TV Line Quality Level B Locate (Buried) (Existing)	6	UT-BuriedCable-Existing(B)	1
	utprrd	CATVBurC_ep	Cable TV Line Quality Level C Locate (Buried) (Existing)	6	UT-BuriedCable-Existing(C)	1
	utprrd	CATVBurD_ep	Cable TV Line Quality Level D Locate (Buried) (Existing)	6	UT-BuriedCable-Existing(D)	1
X	utprrd	CATVCond	Cable TV Conduit System	6	SG-Conduit	2
	utprrd	CATVCondBurB_ep	Cable TV Conduit System Quality Level B Locate (Buried) (Existing)	6	UT-BuriedCable-Existing(B)	1
	utprrd	CATVCondBurC_ep	Cable TV Conduit System Quality Level C Locate (Buried) (Existing)	6	UT-BuriedCable-Existing(C)	1
	utprrd	CATVCondBurD_ep	Cable TV Conduit System Quality Level D Locate (Buried) (Existing)	6	UT-BuriedCable-Existing(D)	1
	utprrd	CATVMisc	Cable TV Service Box and Miscellaneous	6	0 / Continuous	2
	utprrd	CATVMisc_ep	Cable TV Service Box and Miscellaneous, Pole (Existing)	6	1 / DGN1	1
	utprrd	COGO_dp	COGO Information	3	0 / Continuous	1
X	utprrd	Conduit	Conduit for Utilities and Encasements	3	SG-Conduit	2
	utprrd	ConduitB_ep	Utility Conduit & Encasements Quality Level B Locate (Existing)	3	UT-Casing-Existing(B)	1
	utprrd	ConduitC_ep	Utility Conduit & Encasements Quality Level C Locate (Existing)	3	UT-Casing-Existing(C)	1
	utprrd	ConduitD_ep	Utility Conduit & Encasements Quality Level D Locate (Existing)	3	UT-Casing-Existing(D)	1
X	utprrd	ConduitAG	Conduit (Above Ground)	4	SG-ConduitAG-Proposed	1
X	utprrd	ConduitBM	Conduit – Bridge Mount	5	SG-ConduitBM-Proposed	1
X	utprrd	ConduitDB	Conduit – Directional Bore	2	SG-ConduitDB-Proposed	1
X	utprrd	ConduitJB	Conduit – Jack & Bore Under Rail	3	SG-ConduitJB-Proposed	1
X	utprrd	ConduitOT	Conduit – Open Trench	1	SG-ConduitOT-Proposed	1
	utprrd	ConstLines	Construction Lines and Preferences	1	0 / Continuous	0
	utprrd	ConstLines_pm	Construction Lines	4	0 / Continuous	0
X	utprrd	Controller_ep	Controller and Accessories (Existing)	0	2 / DGN2	1
X	utprrd	ControllerB_ep	Controller - Base Mounted (Existing)	0	2 / DGN2	1
X	utprrd	ControllerP_ep	Controller Pole Mount (Existing)	0	2 / DGN2	1
	utprrd	DimLines_dp	Dimension Lines, Corresponding Terminators, Equation Lines	0	0 / Continuous	1
	utprrd	Duct	Duct Pipe (Buried)	7	UT-Duct-Proposed	2
	utprrd	DummyChains_ep	Dummy Chains (Existing)	0	0 / Continuous	1
X	utprrd	EaseLicLine	Easement License Agreement Line	5	6 / DGN6	0
X	utprrd	ElecAer	Electrical Lines (Aerial)	3	UT-OverheadElec-Proposed	2
	utprrd	ElecAer_ep	Electrical Conductors (Distribution & Transmission) (Aerial) (Existing)	3	UT-OverheadElec-Existing	1
	utprrd	ElecAerPri_ep	Conductors (Primary Distribution) (Aerial) (Existing)	3	UT-OverheadElec-Existing	1
	utprrd	ElecAerSec_ep	Conductors (Secondary Distribution) (Aerial) (Existing)	3	UT-OverheadElec-Existing	1
X	utprrd	ElecBur	Electrical (Buried)	3	UT-BuriedElec-Proposed	2
	utprrd	ElecBurB_ep	Electrical Quality Level B Locate (Buried) (Existing)	3	UT-BuriedElec-Existing(B)	1
	utprrd	ElecBurC_ep	Electrical Quality Level C Locate (Buried) (Existing)	3	UT-BuriedElec-Existing(C)	1

Critical	Rule File	Level Name	Level Description	ByLevel Color	ByLevelStyle / Linetype	ByLevel Weight
	utprdd	ElecBurCap_ep	Capacitors (Buried) (Existing)	3	1 / DGN1	1
	utprdd	ElecBurD_ep	Electrical Quality Level D Locate (Buried) (Existing)	3	UT-BuriedElec-Existing(D)	1
	utprdd	ElecBurPriB_ep	Conductors (Primary Distribution) Quality Level B Locate (Buried) (Existing)	3	UT-BuriedElec-Existing(B)	1
	utprdd	ElecBurPriC_ep	Conductors (Primary Distribution) Quality Level C Locate (Buried) (Existing)	3	UT-BuriedElec-Existing(C)	1
	utprdd	ElecBurPriD_ep	Conductors (Primary Distribution) Quality Level D Locate (Buried) (Existing)	3	UT-BuriedElec-Existing(D)	1
	utprdd	ElecBurSecB_ep	Conductor (Secondary Distribution) Quality Level B Locate (Buried) (Existing)	3	UT-BuriedElec-Existing(B)	1
	utprdd	ElecBurSecC_ep	Conductor (Secondary Distribution) Quality Level C Locate (Buried) (Existing)	3	UT-BuriedElec-Existing(C)	1
	utprdd	ElecBurSecD_ep	Conductor (Secondary Distribution) Quality Level D Locate (Buried) (Existing)	3	UT-BuriedElec-Existing(D)	1
	utprdd	ElecMisc	Fuses, Reclosures, Regulator, Sectionalizers	3	0 / Continuous	2
	utprdd	ElecMisc_ep	Capacitors (Above Ground), Switchgear, Transformer, Electrical Service Box (Existing)	3	1 / DGN1	1
X	utprdd	ElecOutlet	Electrical Outlet	3	0 / Continuous	2
	utprdd	ElecOutlet_ep	Electrical Outlet (Existing)	3	1 / DGN1	1
X	utprdd	ElecServ	Electrical Service Miscellaneous	3	0 / Continuous	2
X	utprdd	ElecServWire	Electrical Service Wire	3	0 / Continuous	2
X	utprdd	FireHydrant	Fire Hydrant	1	0 / Continuous	2
	utprdd	FireHydrant_ep	Fire Hydrant (Existing)	1	1 / DGN1	1
	utprdd	FloodLight_ep	Flood Light (Existing)	3	1 / DGN1	1
X	utprdd	FOCAer	Fiber Optics Cable (Aerial)	6	UT-OverheadFOC-Proposed	2
X	utprdd	FOCBur	Fiber Optics Cable (Buried)	6	UT-BuriedFOC-Proposed	2
	utprdd	FOCBurB_ep	Fiber Optics Cable Quality Level B Locate (Buried) (Existing)	6	UT-BuriedFOC(B)-Existing	1
	utprdd	FOCBurC_ep	Fiber Optics Cable Quality Level C Locate (Buried) (Existing)	6	UT-BuriedFOC(C)-Existing	1
	utprdd	FOCBurD_ep	Fiber Optics Cable Quality Level D Locate (Buried) (Existing)	6	UT-BuriedFOC(D)-Existing	1
X	utprdd	FOEElecAer	Fiber Optics Electrical (Aerial)	3	UT-OverheadFOE-Proposed	2
	utprdd	FOEElecAer_ep	Fiber Optics Electrical (Aerial) (Existing)	3	UT-OverheadFOE-Existing	1
X	utprdd	FOEElecBur	Fiber Optics Electrical (Buried)	3	UT-BuriedFOE-Proposed	2
	utprdd	FOEElecBurB_ep	Fiber Optics Electrical Quality Level B Locate (Buried) (Existing)	3	UT-BuriedFOE(B)-Existing	1
	utprdd	FOEElecBurC_ep	Fiber Optics Electrical Quality Level C Locate (Buried) (Existing)	3	UT-BuriedFOE(C)-Existing	1
	utprdd	FOEElecBurD_ep	Fiber Optics Electrical Quality Level D Locate (Buried) (Existing)	3	UT-BuriedFOE(D)-Existing	1
X	utprdd	FOTAer	Fiber Optics Telephone (Aerial) (Size Unknown)	6	UT-OverheadFOT-Proposed	2
	utprdd	FOTAer_ep	Fiber Optics Telephone (Aerial) (Size Unknown) (Existing)	6	UT-OverheadFOT-Existing	1
X	utprdd	FOTBur	Fiber Optics Telephone (Buried) (Size Unknown)	6	UT-BuriedFOT-Proposed	2
	utprdd	FOTBurB_ep	Fiber Optics Telephone Quality Level B Locate (Buried) (Size Unknown) (Existing)	6	UT-BuriedFOT(B)-Existing	1
	utprdd	FOTBurC_ep	Fiber Optics Telephone Quality Level C Locate (Buried) (Size Unknown) (Existing)	6	UT-BuriedFOT(C)-Existing	1
	utprdd	FOTBurD_ep	Fiber Optics Telephone Quality Level D Locate (Buried) (Size Unknown) (Existing)	6	UT-BuriedFOT(D)-Existing	1
X	utadrd	Gas	Gas Pipe and Fittings	4	UT-Gas-Proposed	2
	utadrd	Gas_ep	Gas Test & Miscellaneous (Existing)	4	1 / DGN1	1
	utadrd	GasB_ep	Gas Line (All Sizes) Quality Level B Locate (Existing)	4	UT-Gas-Existing(B)	1
	utadrd	GasC_ep	Gas Line (All Sizes) Quality Level C Locate (Existing)	4	UT-Gas-Existing(C)	1
	utadrd	GasD_ep	Gas Line (All Sizes) Quality Level D Locate (Existing)	4	UT-Gas-Existing(D)	1
	utprdd	GasMisc	Gas Regulator and Miscellaneous Items	4	0 / Continuous	2
X	utprdd	Gauges	Gauges	0	0 / Continuous	2
	utprdd	Gauges_ep	Gauges (Existing)	0	1 / DGN1	1
X	utprdd	Generator	Emergency Generator	0	0 / Continuous	2
X	utprdd	GuyWire	Guy Wire	3	0 / Continuous	2
	utprdd	GuyWire_ep	Guy Anchor, Guy pole, Span Guys (Existing)	3	1 / DGN1	1
	utprdd	ImageAttachment_dp	Image Attachments	0	0 / Continuous	0
X	utprdd	InterconCable_ep	Interconnect Cable (Existing)	1	SG-InterconCable-Existing	0

Critical	Rule File	Level Name	Level Description	ByLevel Color	ByLevelStyle / Linetype	ByLevel Weight
X	utprdd	JunctBox	Junction Boxes, Service Cabinet (Elec/Tel)	3	0 / Continuous	2
	utprdd	JunctBox_ep	Junction Box / Service Cabinet (Elec/Tel) (Existing)	3	1 / DGN1	1
X	utprdd	JunctBoxA	Junction Boxes (Aerial)	3	0 / Continuous	1
X	utprdd	JunctBoxA_ep	Junction Boxes (Aerial) (Existing)	3	1 / DGN1	0
	utprdd	LeaderLine_dp	Leader Line and Terminator with Text	0	0 / Continuous	1
	utprdd	LiteCond_ep	Street Lighting Conductors Existing (Existing)	3	SG-Conduit-Existing	0
X	utprdd	LoadCenter	Load Center	2	0 / Continuous	1
X	utprdd	LoadCenter_ep	Load Center (Existing)	2	5 / DGN5	0
X	utprdd	LoopLI_ep	Loop Lead-In (Existing)	3	2 / DGN2	0
X	utprdd	Loops_ep	Loop Assembly (All Types) (Existing)	2	2 / DGN2	2
X	utprdd	Luminaire	Luminaires (Decorative) (All Types)	2	0 / Continuous	1
	utprdd	Luminaire_ep	Street Light / Pole (Existing)	3	1 / DGN1	1
	utprdd	Manhole_ex	Manhole on Cross Sections (Existing)	10	3 / DGN3	2
	utprdd	Manhole_px	Manhole on Cross Sections	10	0 / Continuous	2
	utprdd	ManholeCOMM	Manhole (Communications)	6	0 / Continuous	1
	utprdd	ManholeCOMM_ep	Manhole (Communications) (Existing)	6	1 / DGN1	1
X	utprdd	ManholeElec	Manhole (Electric)	3	0 / Continuous	2
	utprdd	ManholeElec_ep	Manhole (Electric) (Existing)	3	1 / DGN1	1
X	utprdd	ManholeGas	Manhole (Gas)	4	0 / Continuous	2
	utprdd	ManholeGas_ep	Manhole (Gas) (Existing)	4	1 / DGN1	1
X	utprdd	ManholeSS	Manhole (Sanitary Sewer)	2	0 / Continuous	2
	utprdd	ManholeSS_ep	Manhole (Sanitary Sewer) (Existing)	2	1 / DGN1	1
X	utprdd	ManholeSW	Manhole (Storm Water)	10	0 / Continuous	2
	utprdd	ManholeSW_ep	Manhole (Storm Water) (Existing)	10	1 / DGN1	1
X	utprdd	ManholeTel	Manhole (Telephone)	6	0 / Continuous	2
	utprdd	ManholeTel_ep	Manhole (Telephone) (Existing)	6	1 / DGN1	1
X	utprdd	ManholeUnknown	Manhole (Unknown)	0	0 / Continuous	2
	utprdd	ManholeUnknown_ep	Manhole (Unknown) (Existing)	0	1 / DGN1	1
	utprdd	ManholeWater	Manhole (Water)	1	0 / Continuous	1
	utprdd	ManholeWater_ep	Manhole (Water) (Existing)	1	1 / DGN1	1
X	utprdd	MeterElec	Meter (Electric)	3	0 / Continuous	2
	utprdd	MeterElec_ep	Meter (Electric) (Existing)	3	1 / DGN1	1
	utprdd	MeterElecBur_ep	Meter (Electric) (Buried) (Existing)	3	1 / DGN1	1
X	utprdd	MeterGas	Meter (Gas)	4	0 / Continuous	2
	utprdd	MeterGas_ep	Meter (Gas) (Existing)	4	1 / DGN1	1
	utprdd	MeterUnk	Meter (Unknown)	0	0 / Continuous	2
	utprdd	MeterUnk_ep	Meter (Unknown) (Existing)	0	1 / DGN1	1
X	utprdd	MeterWater	Water Meter	1	0 / Continuous	2
	utprdd	MeterWater_ep	Meter (Water) (Existing)	1	1 / DGN1	1
	utprdd	Miscellaneous0	Undefined Proposed Item - Color Blue Weight 0	1	0 / Continuous	0
	utprdd	Miscellaneous1	Undefined Proposed Item - Color Blue Weight 1	1	0 / Continuous	1
	utprdd	Miscellaneous2	Undefined Proposed Item - Color Blue Weight 2	1	0 / Continuous	2
	utprdd	Miscellaneous3	Undefined Proposed Item - Color Green Weight 0	2	0 / Continuous	0
	utprdd	Miscellaneous4	Undefined Proposed Item - Color Green Weight 1	2	0 / Continuous	1
	utprdd	Miscellaneous5	Undefined Proposed Item - Color Green Weight 2	2	0 / Continuous	2
	utprdd	Miscellaneous6	Undefined Proposed Item - Color Red Weight 0	3	0 / Continuous	0
	utprdd	Miscellaneous7	Undefined Proposed Item - Color Red Weight 1	3	0 / Continuous	1

Critical	Rule File	Level Name	Level Description	ByLevel Color	ByLevelStyle / Linetype	ByLevel Weight
	utprdd	Miscellaneous8	Undefined Proposed Item - Color Red Weight 2	3	0 / Continuous	2
	utprdd	Miscellaneous9	Undefined Proposed Item - Color Red Weight 3	3	0 / Continuous	3
	utprdd	NonPlottingEle_dp	Non-Plotting Items - Construction Elements, Type 66 Elements, Etc.	4	0 / Continuous	0
X	utprdd	Oil	Oil Pipeline, Petroleum	4	UT-Petroleum-Proposed	2
	utprdd	Oil_B_ep	Oil Line (All Sizes) Quality Level B Locate (Existing)	4	UT-Petroleum-Existing(B)	1
	utprdd	Oil_C_ep	Oil Line (All Sizes) Quality Level C Locate (Existing)	4	UT-Petroleum-Existing(C)	1
	utprdd	Oil_D_ep	Oil Line (All Sizes) Quality Level D Locate (Existing)	4	UT-Petroleum-Existing(D)	1
X	utprdd	OverheadSign_ep	Overhead Sign Panels (Existing)	0	3 / DGN3	1
X	utprdd	OverheadStr_ep	Mast Arm, Truss Assemblies, Signal Arms and Supports (Existing)	0	3 / DGN3	1
	utprdd	Patternlines_ep	Cross Section Chain (Existing)	2	1 / DGN1	0
	utprdd	PayItem_dp	Pay Item Number Label Elements	4	0 / Continuous	2
X	utprdd	Pedestal_ep	Pedestal (Existing)	1	2 / DGN2	1
X	utprdd	PedHead_ep	Pedestrian Head (All Types) (Existing)	0	2 / DGN2	1
	utprdd	PedSignal_ep	Pedestrian Signal Unit, Signage (Existing)	0	2 / DGN2	0
	utprdd	PipeEncaseB_ep	Pipe Encasements Quality Level B Locate (Existing)	0	UT-Casing-Existing(B)	1
	utprdd	PipeEncaseC_ep	Pipe Encasements Quality Level C Locate (Existing)	0	UT-Casing-Existing(C)	1
	utprdd	PipeEncaseD_ep	Pipe Encasements Quality Level D Locate (Existing)	0	UT-Casing-Existing(D)	1
	utprdd	PointLocator_ep	Point Locator Symbol (Existing)	4	0 / Continuous	0
X	utprdd	PoleConc	Concrete Strain Pole	0	0 / Continuous	2
X	utprdd	PoleConc_ep	Concrete Strain Pole (Existing)	0	2 / DGN2	1
X	utprdd	PoleElec	Electrical Pole w/ Transformer	3	0 / Continuous	2
	utprdd	PoleElec_ep	Electrical Pole With or Without Transformer, Shared Pole (Existing)	3	1 / DGN1	1
X	utprdd	PoleFound	Pole Foundation	0	0 / Continuous	2
X	utprdd	PoleLight	Light Pole	2	0 / Continuous	1
X	utprdd	PoleLight_ep	Light Pole (Existing)	2	2 / DGN2	1
X	utprdd	PoleLightHM	High Mast Light Pole	3	0 / Continuous	1
X	utprdd	PoleLightHM_ep	High Mast Light Pole (Existing)	2	2 / DGN2	1
	utprdd	PoleLightID	Light Pole Location / ID	4	0 / Continuous	1
X	utprdd	PoleShared	Power Pole Electric (Above Ground) Shared w/ Transformer	3	0 / Continuous	2
X	utprdd	PoleSteelStrain	Steel Strain Pole	0	0 / Continuous	2
X	utprdd	PoleSteelStrain_ep	Steel Strain Pole (Existing)	0	2 / DGN2	1
X	utprdd	PoleTel	Telephone Pole	6	0 / Continuous	2
	utprdd	PoleTel_ep	Telephone Pole (Existing)	6	1 / DGN1	1
X	utprdd	PoleUtil	Utility Pole	0	0 / Continuous	2
X	utprdd	PoleWoodStrain	Wood Strain Pole	0	0 / Continuous	2
X	utprdd	PoleWoodStrain_ep	Wood Strain Pole (Existing)	0	2 / DGN2	1
X	utprdd	PullBox	Pull Boxes (All Types)	3	0 / Continuous	1
	utprdd	PullBox_ep	Wiring Pull Box (Existing)	3	1 / DGN1	1
	utprdd	Pump	Pump (Petroleum / Fuel)	7	0 / Continuous	2
X	utprdd	PumpNonPet	Pump (Non Petroleum)	1	0 / Continuous	2
	utprdd	PumpNonPet_ep	Pump (Non Petroleum) (Existing)	1	1 / DGN1	1
	utprdd	ReferencePt_dp	Survey and Construction Reference Point Details and Elements	4	0 / Continuous	2
X	utprdd	SanitaryFM	Force Main Lines	2	UT-Sanitary-Proposed	2
	utprdd	SanitaryFM_B_ep	Force Main (All Sizes) Quality Level B Locate (Existing)	2	UT-Sanitary-Existing(B)	1
	utprdd	SanitaryFM_C_ep	Force Main (All Sizes) Quality Level C Locate (Existing)	2	UT-Sanitary-Existing(C)	1
	utprdd	SanitaryFM_D_ep	Force Main (All Sizes) Quality Level D Locate (Existing)	2	UT-Sanitary-Existing(D)	1
X	utprdd	SanitarySewer	Sanitary Sewer	2	UT-Sanitary-Proposed	2



Critical	Rule File	Level Name	Level Description	ByLevel Color	ByLevelStyle / Linetype	ByLevel Weight
	utprdd	SanitarySewerB_ep	Sanitary Sewer (All Sizes) Quality Level B Locate (Existing)	2	UT-Sanitary-Existing(B)	1
	utprdd	SanitarySewerC_ep	Sanitary Sewer (All Sizes) Quality Level C Locate (Existing)	2	UT-Sanitary-Existing(C)	1
	utprdd	SanitarySewerD_ep	Sanitary Sewer (All Sizes) Quality Level D Locate (Existing)	2	UT-Sanitary-Existing(D)	1
X	utprdd	SanitarySewerDSta	Sewer Dump Station	2	0 / Continuous	2
	utprdd	SanitarySewerDSta_ep	Dump Station (SS) (Existing)	2	2 / DGN2	1
X	utprdd	SanitarySewerEff	Sanitary Sewer Effluent NPW	5	UT-NonPotableWater-Proposed	2
X	utprdd	SanitarySewerEff_ex	Sanitary Effluent on Cross Sections (Existing)	5	0 / Continuous	0
X	utprdd	SanitarySewerEff_px	Sanitary Effluent on Cross Sections	5	0 / Continuous	0
	utprdd	SanitarySewerMisc	Sewer Items(Miscellaneous)	2	0 / Continuous	2
	utprdd	SanitarySewerMisc_ep	Cleanout, Sanitary Effluent (Open Channel), Pump Station (Existing)	2	1 / DGN1	1
	utprdd	SateDish_ep	SatteliteSatellite Dish Antenna (Existing)	6	4 / DGN4	1
	utprdd	Scratch1_dp	Scratch Level for Temporary or Informational Items	4	0 / Continuous	0
	utprdd	Scratch2_dp	Scratch Level for Temporary or Informational Items	5	0 / Continuous	0
	utprdd	ScratchEle_dp	Scratch Level for Draft Elements, Temporary Elements, Etc. (DO NOT PLOT)	3	0 / Continuous	0
	utprdd	ScratchEle2_dp	Scratch Level for Draft Elements, Temporary Elements, Etc. (DO NOT PLOT)	4	0 / Continuous	0
	utprdd	Signal_ep	Signal Head, Signal on Pedestal (Existing)	3	1 / DGN1	1
X	utprdd	SignalHead_ep	Signal Head Section Details (Existing)	2	2 / DGN2	0
	utprdd	SignalLoop_ep	Traffic Detector Loops (Existing)	7	1 / DGN1	2
	utprdd	SignalMisc_ep	Signal Equipment Including Control Unit (Miscellaneous) (Existing)	3	2 / DGN2	0
	utprdd	SignalSupport_ep	Signal Supports Including Mast Arm (Existing)	3	2 / DGN2	0
X	utprdd	SignalSym_ep	Signal Head Symbols (Existing)	3	2 / DGN2	0
X	utprdd	SignCantilever_ep	Sign Symbol Cantilever (Existing)	0	2 / DGN2	0
	utprdd	SignMulti_ep	Multi-column Sign (All Signs) (Existing)	0	3 / DGN3	1
X	utprdd	SignPanel_ep	Sign Panel Elements (Existing)	0	2 / DGN2	1
	utprdd	SignSingle_ep	Sign (Single Support) (Existing)	3	2 / DGN2	0
X	utprdd	SignSpanwire	Span Wire Signing Assembly	2	0 / Continuous	1
X	utprdd	SignSpanwire_ep	Span Wire Signing Assembly (Existing)	2	2 / DGN2	1
	utprdd	SignSupport_ep	Trusses and Cantilevers for Overhead Signs (Existing)	0	3 / DGN3	1
X	utprdd	SignTruss_ep	Sign Symbol Truss (Existing)	3	2 / DGN2	1
	utprdd	SpanWire_ep	Signal / Span Wire Pole (Existing)	3	2 / DGN2	0
X	utprdd	Sprinkler	Sprinkler Head	1	0 / Continuous	2
	utprdd	Sprinkler_ep	Sprinkler Head (Existing)	1	1 / DGN1	1
X	utprdd	Steam	Steam Pipes	1	UT-Steam-Proposed	2
	utprdd	SteamB_ep	Steam Line Quality Level B Locate (Existing)	4	UT-Steam-Existing(B)	1
	utprdd	SteamC_ep	Steam Line Quality Level C Locate (Existing)	4	UT-Steam-Existing(C)	1
	utprdd	SteamD_ep	Steam Line Quality Level D Locate (Existing)	4	UT-Steam-Existing(D)	1
X	utprdd	StreetLights	Street Lights	2	0 / Continuous	1
	utprdd	SU_QLB_ep	Subsurface Utility Quality Level B Locate Point (Existing)	0	0 / Continuous	1
	utprdd	SU_QLC_ep	Subsurface Utility Quality Level C Locate Point (Existing)	0	0 / Continuous	1
	utprdd	SU_QLD_ep	Subsurface Utility Quality Level D Locate Point (Existing)	0	0 / Continuous	1
X	utprdd	Switchgear	Switchgear and Appurtenances	3	0 / Continuous	2
	utprdd	Tables_dp	Data Tables and All Autodesk Tables	0	0 / Continuous	1
X	utprdd	TeleAer	Telephone (Aerial)	6	UT-OverheadTel-Proposed	2
	utprdd	TeleAer_ep	Telephone (Aerial) (Existing)	6	UT-OverheadTel-Existing	1
X	utprdd	TeleBur	Telephone (Buried)	6	UT-BuriedTel-Proposed	2
X	utprdd	TeleBur_px	Telephone on Cross Sections (Buried) (Miscellaneous)	6	0 / Continuous	1
	utprdd	TeleBurB_ep	Telephone (All Sizes) Quality Level B Locate (Buried) (Existing)	6	UT-BuriedTel-Existing(B)	1

Critical	Rule File	Level Name	Level Description	ByLevel Color	ByLevelStyle / Linetype	ByLevel Weight
	utprdd	TeleBurC_ep	Telephone (All Sizes) Quality Level C Locate (Buried) (Existing)	6	UT-BuriedTel-Existing(C)	1
	utprdd	TeleBurD_ep	Telephone (All Sizes) Quality Level D Locate (Buried) (Existing)	6	UT-BuriedTel-Existing(D)	1
	utprdd	TeleMisc	Telephone Service Box, Booth or Pedestal	6	0 / Continuous	2
	utprdd	TeleMisc_ep	Telephone Service Box, Booth or Pedestal (Existing)	6	1 / DGN1	1
	utprdd	TextBLStation	Text - B/L Station and Tics	0	0 / Continuous	2
	utprdd	TextConstEle	Text - Construction Element	0	0 / Continuous	1
	utprdd	TextCurveData	Text - Curve Data Note	0	0 / Continuous	2
	utprdd	TextDetails	Text - Detail Notes	4	0 / Continuous	2
	utprdd	TextDrainInvElev_ep	Text - Drainage Invert Elevation (Existing)	0	0 / Continuous	1
	utprdd	TextDrainLabel_ep	Text - Drainage (Existing)	0	0 / Continuous	1
	utprdd	TextElevLabel	Text - Elevation Labels	4	0 / Continuous	0
	utprdd	TextLabel	Text - Label	0	0 / Continuous	2
	utprdd	TextLandscape	Text - Landscape Labels	0	0 / Continuous	1
	utprdd	TextMajor	Text - Major	0	0 / Continuous	5
	utprdd	TextMinor	Text - Minor	0	0 / Continuous	0
	utprdd	TextMisc	Text - Miscellaneous	0	0 / Continuous	1
	utprdd	TextNotes	Text - Notes	4	0 / Continuous	1
	utprdd	TextProfLabel	Text - Profile, Horizontal and Vertical Axis Labels	0	0 / Continuous	2
	utprdd	TextProjLabel	Text - Begin and End ProjectLabel with Leader Lines	1	0 / Continuous	2
	utprdd	TextPtLabel	Text - Point Labels	4	0 / Continuous	0
	utprdd	TextShtNo	Text - Sheet Number	0	0 / Continuous	2
	utprdd	TextSubUtilLabel_ep	Text - Subsurface Utilities (Existing)	0	0 / Continuous	1
	utprdd	TextSurveyLabel	Text - Survey Text Labels	0	0 / Continuous	0
	utprdd	TextTables	Text - Key Sheet Indexes and Table Data	4	0 / Continuous	2
	utprdd	TextTitle	Text - Title	0	0 / Continuous	3
	utprdd	TextTopoLabel_ep	Text - Topography (Existing)	0	0 / Continuous	1
	utprdd	TextUtilLabel_ep	Text - Utilities (Existing)	0	0 / Continuous	1
	utprdd	TextXSElev	Text - Cross Section Elevations	2	0 / Continuous	1
	utprdd	TopoMisc_ep	Topography (Miscellaneous) (Existing)	0	3 / DGN3	1
X	utprdd	Tower	High Mast Light Poles or Towers, Transmission Tower, Antenna	3	0 / Continuous	2
	utprdd	Tower_ep	High Mast Light Poles or Towers, Transmission Tower, Antenna (Existing)	3	1 / DGN1	1
X	utprdd	TransformerAer	Transformer Unit (Above Ground)	3	0 / Continuous	2
X	utprdd	TransformerBur	Transformer (Buried)	3	0 / Continuous	2
X	utprdd	TransmissionAer	Electric Conductors (Distribution & Transmission) (Aerial)	3	UT-OverheadElec-Proposed	2
X	utprdd	TransmissionBur	Electric Conductors (Distribution & Transmission) (Buried)	3	UT-BuriedElec-Proposed	2
X	utprdd	TransmissionT	Transmission Tower Single	3	0 / Continuous	2
	utprdd	UtilMisc_ep	Utility Items (Miscellaneous) (Existing)	0	0 / Continuous	0
	utprdd	UtilsMisc	Utility Items (Miscellaneous)	8	0 / Continuous	2
X	utprdd	UtilsProposed	Facilities/Utilities as Shown in Utility Adjustments	9	0 / Continuous	2
X	utprdd	Valve	Valve, Valve Box (Unknown)	0	0 / Continuous	2
	utprdd	Valve_ep	Valve, Valve Box (Existing)	0	1 / DGN1	1
X	utprdd	ValveCover	Valve Cover (Unknown)	0	0 / Continuous	2
	utprdd	ValveCover_ep	Valve Cover (Unknown) (Existing)	0	1 / DGN1	1
X	utprdd	ValveCvrEff	Valve Cover (Effluent)	5	0 / Continuous	2
	utprdd	ValveCvrEff_ep	Valve Cover (Effluent) (Existing)	5	1 / DGN1	1
X	utprdd	ValveCvrGas	Valve Cover (Gas)	4	0 / Continuous	2
	utprdd	ValveCvrGas_ep	Valve Cover (Gas) (Existing)	4	1 / DGN1	1



Critical	Rule File	Level Name	Level Description	ByLevel Color	ByLevelStyle / Linetype	ByLevel Weight
X	utprdd	ValveCvrSewer	Valve Cover (Sewer)	2	0 / Continuous	2
	utprdd	ValveCvrSewer_ep	Valve Cover (Sewer) (Existing)	2	1 / DGN1	1
X	utprdd	ValveCvrWater	Valve Cover (Water)	1	0 / Continuous	2
	utprdd	ValveCvrWater_ep	Valve Cover (Water) (Existing)	1	1 / DGN1	1
X	utprdd	ValveCvrWaterNP	Water Line Non Potable	5	0 / Continuous	2
	utprdd	ValveCvrWaterNP_ep	Valve Cover (Non-potable Water) (Existing)	5	1 / DGN1	1
X	utprdd	ValveGas	Valve, Valve Box (Gas)	4	0 / Continuous	2
	utprdd	ValveGas_ep	Valve (Gas), Valve Box (Existing)	4	1 / DGN1	1
X	utprdd	ValveSewer	Valve, Valve Box (Sewer)	2	0 / Continuous	2
	utprdd	ValveSewer_ep	Valve (Sewer), Valve Box (Existing)	2	1 / DGN1	1
X	utprdd	ValveWater	Valve, Valve Box (Water)	1	0 / Continuous	2
	utprdd	ValveWater_ep	Valve (Water), Valve Box (Existing)	1	1 / DGN1	1
X	utprdd	ValveWaterNP	Water Line (Non Potable)	5	0 / Continuous	2
	utprdd	ValveWaterNP_ep	Valve (Non-potable Water), Valve Box (Existing)	8	1 / DGN1	1
	utprdd	Vault_ep	Vaults Above Grade and Below Grade (Existing)	3	1 / DGN1	0
X	utprdd	Vaults	Vaults Above Grade and Below Grade	3	0 / Continuous	2
X	utprdd	VaultsRW	Vaults (Raw Water)	1	0 / Continuous	2
	utprdd	Vent	Vent (Unknown)	0	0 / Continuous	2
	utprdd	Vent_ep	Vent (Existing)	0	1 / DGN1	1
X	utprdd	VentGas	Vent (Gas)	4	0 / Continuous	2
	utprdd	VentGas_ep	Vent (Gas) (Existing)	4	1 / DGN1	1
X	utprdd	VentSewer	Vent (Sewer)	2	0 / Continuous	2
	utprdd	VentSewer_ep	Vent (Sewer) (Existing)	2	1 / DGN1	1
	utprdd	Viewport	Viewport (For AutoCAD Use)	3	0 / Continuous	0
X	utprdd	Water	Water Line	1	UT-Water-Proposed	2
	utprdd	WaterB_ep	Water Line (All Sizes) Quality Level B Locate (Existing)	1	UT-Water-Existing(B)	1
	utprdd	WaterC_ep	Water Line (All Sizes) Quality Level C Locate (Existing)	1	UT-Water-Existing(C)	1
	utprdd	WaterD_ep	Water Line (All Sizes) Quality Level D Locate (Existing)	1	UT-Water-Existing(D)	1
X	utprdd	WaterFct	Standpipe and Water Faucet	1	0 / Continuous	2
X	utprdd	WaterFilter	Water Filter	5	0 / Continuous	2
	utprdd	WaterMisc_ep	Faucet, Standpipe (Existing)	1	1 / DGN1	1
X	utprdd	WaterNP	Water Line Non Potable	5	UT-NonPotableWater-Proposed	2
	utprdd	WaterNP_B_ep	Non-potable Water Line (All Sizes) Quality Level B Locate (Existing)	5	UT-NonPotableWater-Existing(B)	1
	utprdd	WaterNP_C_ep	Non-potable Water Line (All Sizes) Quality Level C Locate (Existing)	5	UT-NonPotableWater-Existing(C)	1
	utprdd	WaterNP_D_ep	Non-potable Water Line (All Sizes) Quality Level D Locate (Existing)	5	UT-NonPotableWater-Existing(D)	1
X	utprdd	WaterNP_ex	Raw Water Pipes on Cross Sections (Existing)	5	0 / Continuous	1
X	utprdd	WaterNP_px	Raw Water Pipes on Cross Sections	5	0 / Continuous	1
X	utprdd	Well	Well (Any Size)	1	1 / DGN1	2
	utprdd	Well_ep	Well (Any Size) (Existing)	1	1 / DGN1	1
X	utprdd	WellMon	Well Monitoring	1	0 / Continuous	2
	utprdd	WellMon_ep	Well Monitoring, Taps (Existing)	1	1 / DGN1	1
	utprdd	Xreference01_dp	Reference Files (For AutoCAD Use)	0	0 / Continuous	1
	utprdd	Xreference02_dp	Reference Files (For AutoCAD Use)	0	0 / Continuous	1
	utprdd	Xreference03_dp	Reference Files (For AutoCAD Use)	0	0 / Continuous	1
	utprdd	Xreference04_dp	Reference Files (For AutoCAD Use)	0	0 / Continuous	1
	utprdd	XSCell	GEOPAK Cross Section Cell/Block and Profile Cell/Block	8	0 / Continuous	1