



FDOTConnect for OpenRoads Designer

Existing Features 3D Modeling **COURSE GUIDE**

<https://www.fdot.gov/cadd>

State of Florida
Department of Transportation

FDOTConnect
for
OpenRoads Designer
Existing Features
3D Modeling
Course Guide

2024

PRODUCTION SUPPORT / CADD OFFICE

TALLAHASSEE, FLORIDA

<http://www.fdot.gov/cadd>

FDOTConnect

for

OpenRoads Designer

Existing Features 3D Modeling

Description

This course covers the fundamentals of creating a 3D Model for existing features to include hard surfaces (i.e., asphalt, concrete, sidewalks, curbs, etc....), utilities, drainage structures, and soil borings. Participants will be introduced to Bentley OpenRoads Designer Connect Edition - OpenRoads Technology tools for design and modeling; specifically for Florida Department of Transportation (FDOT) projects using the FDOTConnect10.12 WorkSpace.

Objectives

- Create and set up a GDTMRD file from Survey data
- Create and set up a ALGNRD file from Survey data
- Create and set up a MODLRD_ExistingFeatures file from Survey data
- Create Shapes using FDOT's Create Existing Features Tool
- Create Clipped Existing Feature Terrains
- Apply Surface Templates
- Edit Existing Feature Depth
- Add Curbs to the Existing Features
- Create and set up a RWDTRD file for Existing and Proposed Right of Way Lines
- Show Existing Right of Way Lines for Cross Sections
- Create and set up a MODLRD_ExistingUtilities file from Survey data
- Create and set up a MODLRD_ExistingDrainage file from Survey data
- Create and set up a ABORRD file for Geotechnical Data

Audience

FDOT Roadway Designers and Engineers

Prerequisites

Participants should have a basic understanding of Computer Aided Drafting and Design (CADD) using MicroStation, a basic understanding of OpenRoads Designer Connect Edition - OpenRoads, Technology tools and a solid understanding of the engineering necessary to design a roadway.

Table of Contents

Document Style.....	6
1 CREATING A GDTMRD FILE.....	6
Introduction.....	7
Objective.....	7
Exercise Overview.....	7
Exercise 1.1 Export the Existing Ground by Boundary.....	7
Exercise 1.2 Creating a GDTMRD file.....	9
Exercise 1.3 (Optional) Creating a Complex Terrain.....	12
2 EXISTING FEATURES.....	17
Introduction.....	17
Civil Terrain Modeling.....	17
Workflow Information.....	17
Exercise Overview.....	18
Exercise 2.1 Create and set up a ALGNRD file.....	18
Exercise 2.2 Create and set up a MODLRD_ExistingFeatures file.....	22
Exercise 2.3 Create Existing Feature Shapes.....	24
Exercise 2.4 Create Existing Feature Terrains (External).....	27
Exercise 2.5 (Optional) Creating a 3D Terrain Model Boundary by Active Profile.....	29
Exercise 2.6 Clip Internal Terrains.....	31
Exercise 2.7 Apply Surface Templates.....	33
Exercise 2.8 Edit Existing Feature Depth.....	35
Exercise 2.9 Add Curbs to the Existing Features.....	37
Exercise 2.10 View Existing Cross Sections.....	43
3 EXISTING ROW LINES.....	44
Introduction.....	44
Objective.....	44
Exercise Overview.....	44
Exercise 3.1 Create and set up a RWDTRD file.....	44
Exercise 3.2 View ROW lines in a cross section view.....	48

4	EXISTING UTILITIES MODELING.....	49
	Introduction.....	49
	Objective.....	49
	Exercise Overview.....	49
	Exercise 4.1 Create and set up a MODLRD_ExistingUtilities file.....	50
	Exercise 4.2 Use the Extract From Graphic tool.....	52
	Exercise 4.3 Show Existing Utilities in a Dynamic Cross Section.....	53
	Exercise 4.4 Creating a Profile From Vvh Data.....	54
5	EXISTING DRAINAGE MODELING.....	65
	Introduction.....	65
	Objective.....	65
	Exercise Overview.....	65
	Exercise 5.1 Create and set up a MODLRD_ExistingDrainage file.....	66
	Exercise 5.2 Use the Extract From Graphic tool.....	68
	Exercise 5.3 Show Existing Drainage in a Dynamic Cross Section.....	71
6	GEOTECH DATA MANAGER AND REPORT OF CORE BORINGS SHEETS.....	72
	Introduction.....	72
	Objective.....	72
	Exercise Overview.....	72
	Exercise 6.1 Create and set up a ABORRD file.....	73
	Exercise 6.2 Review delivered GeotechDataSheetTemplate.xlsx spreadsheet.....	75
	Exercise 6.3 Import delivered Geotech Data Template into the Geotech Data Manager.....	78
	Exercise 6.4 Use the Place Boreholes tool to create 2D and 3D models of Geotechnical Data...81	
	Exercise 6.5 Create an Event Points List in the ALGNRD file.....	84
	Exercise 6.6 Create a RDXSRD file to show Borehole information in Cross Sections.....	86
	Exercise 6.7 Use the Report of Borings tool to create the Report of Core Borings Sheet.....	90
	Exercise 6.8 Create a Soil Survey Sheet for plans.....	94

DOCUMENT STYLE

Style conventions used throughout the course guide are shown in the following table.

Item	Convention	Example
Menu names and commands	Bold (Names separated with > symbol)	<ul style="list-style-type: none"> • General form is Workflow (when applicable) > Tab > Group > Tool • File > Open • File > Settings > User > Preferences • OpenBridge Modeler (Workflow) > FDOT > Actions > Create File
Window actions	Bold	<ul style="list-style-type: none"> • Click the Apply button. • Click the Graphic Select button to the right of the Horizontal Alignment Include box. • In the Segment Type list, click Lines.
Window field names	<i>Italic</i>	<ul style="list-style-type: none"> • Key in Hemfield Road in the Alignment Name field. • Click the Graphic Select button to the right of the Horizontal Alignment Include field. • In the Segment Type list, click Lines.
Key-ins	Bold	<ul style="list-style-type: none"> • Key in Hemfield Road in the Alignment Name field.
File names	<i>Italic</i>	<ul style="list-style-type: none"> • <i>Open the file Working Graphics.dgn in the C:\Bentley Training\GEOPAK 101\Project Setup\Practice\ folder.</i>
File paths	<u>Underline</u>	<ul style="list-style-type: none"> • Open the file Working Graphics.dgn in the <u>C:\Bentley Training\GEOPAK 101\Project Setup\Practice\ folder.</u>
New terms or emphasis	<i>Italic or Bold</i>	<ul style="list-style-type: none"> • The Template Library contains templates, which represent typical sections of the proposed roadway. • The user is not to utilize this tool.

1 CREATING A GDTMRD FILE

INTRODUCTION

This course was developed to introduce OpenRoads Designer Connect Edition - OpenRoads Technology tools for design and modeling on Florida Department of Transportation (FDOT) projects. The curriculum was developed within the FDOTConnect10.12 WorkSpace to provide sample exercises for most of the new civil tools on a sample project data set.

OBJECTIVE

This chapter will introduce the OpenRoads Technology tools that will be used for exporting and importing the Existing Ground Terrain from the SURVRD file into a GDTMRD file that can be used for future modeling.

EXERCISE OVERVIEW

Exercise 1.1	Export the Existing Ground by Boundary.....	7
Exercise 1.2	Creating a GDTMRD file.....	9
Exercise 1.3	(Optional) Creating a Complex Terrain.....	12

Exercise 1.1 *Export the Existing Ground by Boundary*



1. Locate the **FDOT 10.12 ORD** icon on the desktop and launch *FDOTConnect10.12 for ORD*.
2. From the *FDOT WorkSpace*, select the WorkSet **22049555201** and click the **Browse** button to navigate to the *Survey* folder. Choose the file *SURVRD01.dgn* and click **Open**.
3. Zoom into the view and select the Terrain *Boundary* element. Be sure to select the element with the level of **DTM_ex** and not the **DTMBoundary_ep** level.

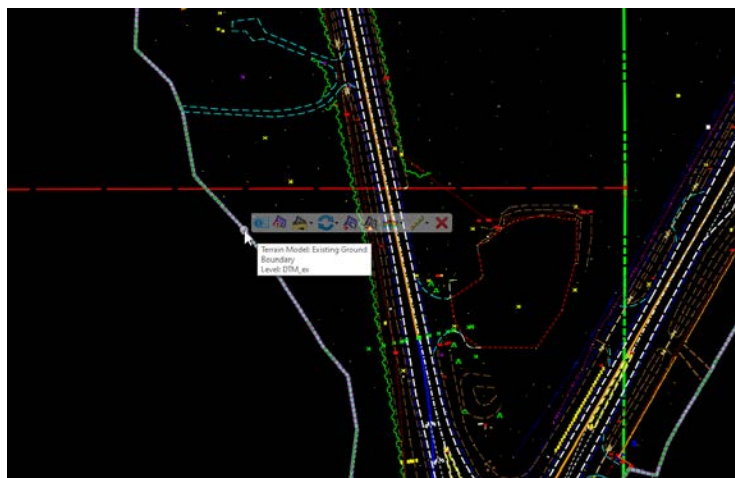

NOTE *Issuing a left click and then multiple right clicks while hovering over the element will cycle through elements that might be stacked.*

4. Select the boundary and hover the cursor to display the context menu. The third icon in the menu, *Export Terrain Model* allows the Terrain to be exported to several formats. Choose the option **LandXML**.

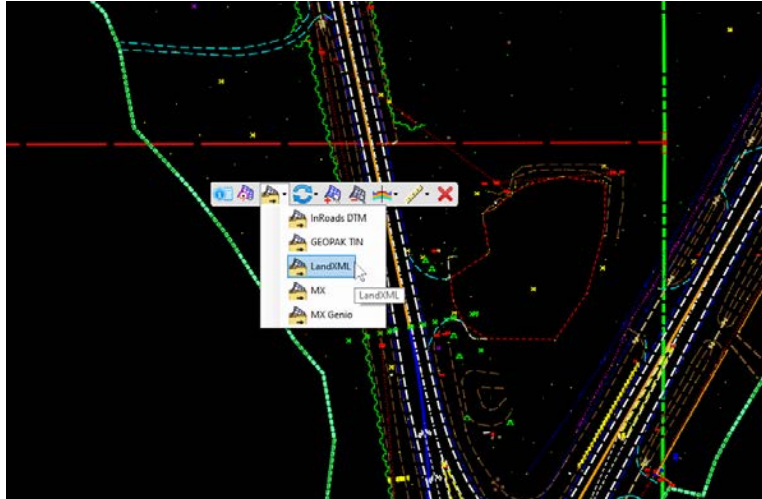

NOTE Alternatively, the pop-up menu export options can be found in the *OpenRoads Model* tab of *Explorer*. Find the terrain under *Terrains>Existing* and right click on it.

5. Fill out the dialog with the below information, and then click through each cursor prompt.

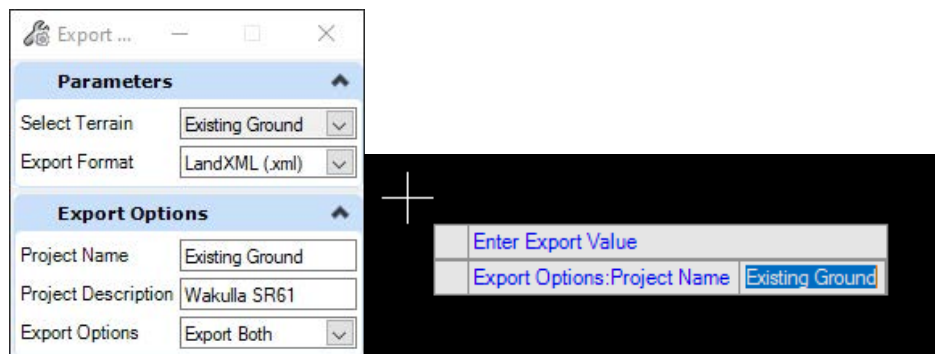

6. Save the file *Existing Ground.xml* into the project *Survey* folder.

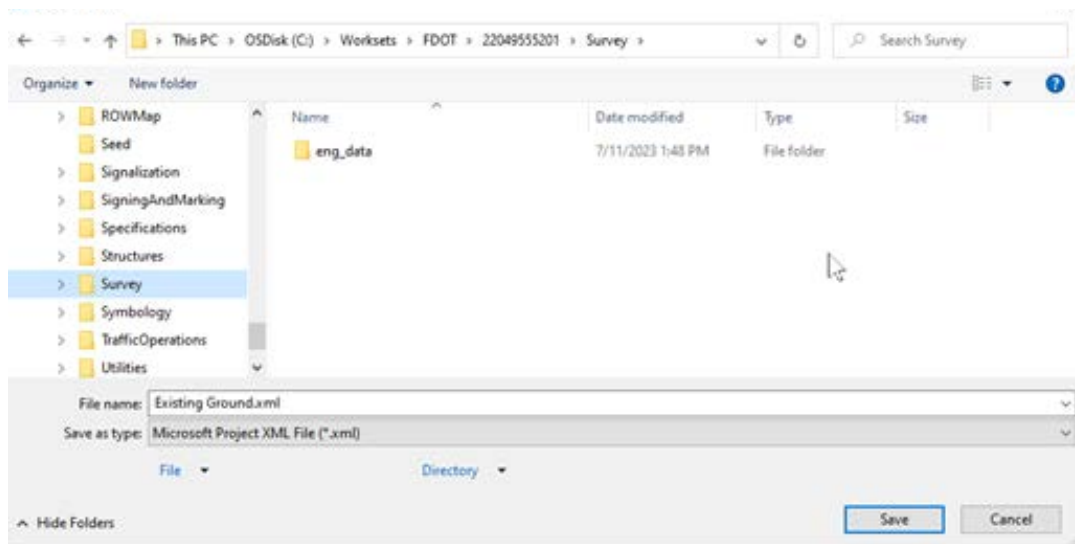

Exercise 1.2 Creating a GDTMRD file

1. Launch the **Create File** tool from the *FDOT* tab of the ribbon in the *Actions* group. Switch the *Discipline* to **Survey** and the *File Group* to **Survey Design Files**. Select the *Base Filename* **GDTMRD** from the list. Select a **Coordinate System** for the file or select a **County** which automatically populates the coordinate system dropdown. Make sure all settings match the dialog below, and then click **Create - Open File**. Close the **Create File** tool.

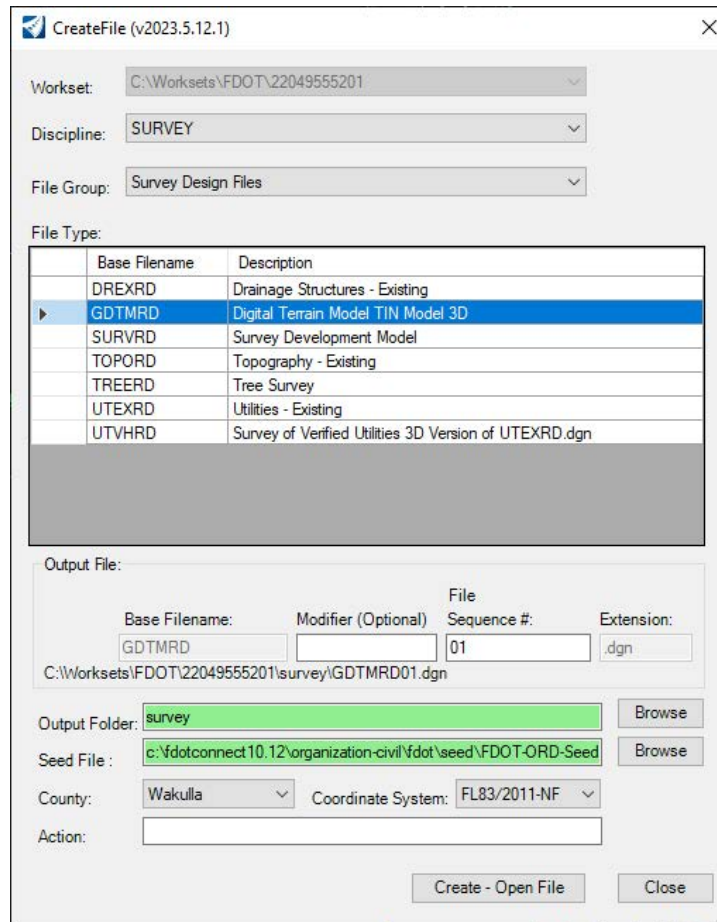
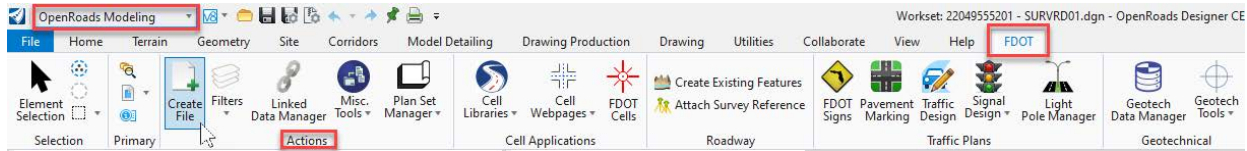

2. From the *Terrain* tab on the ribbon, locate the *Create* group and click **From File** to import terrain model data from a file.

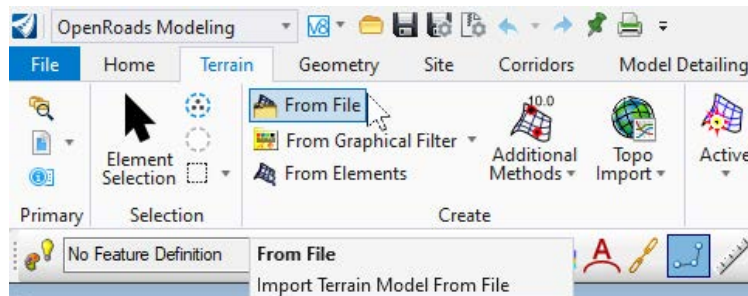

3. A dialog will open prompting for a file to import. Select the *Existing Ground.xml* in the *Survey* folder and click **Done**.

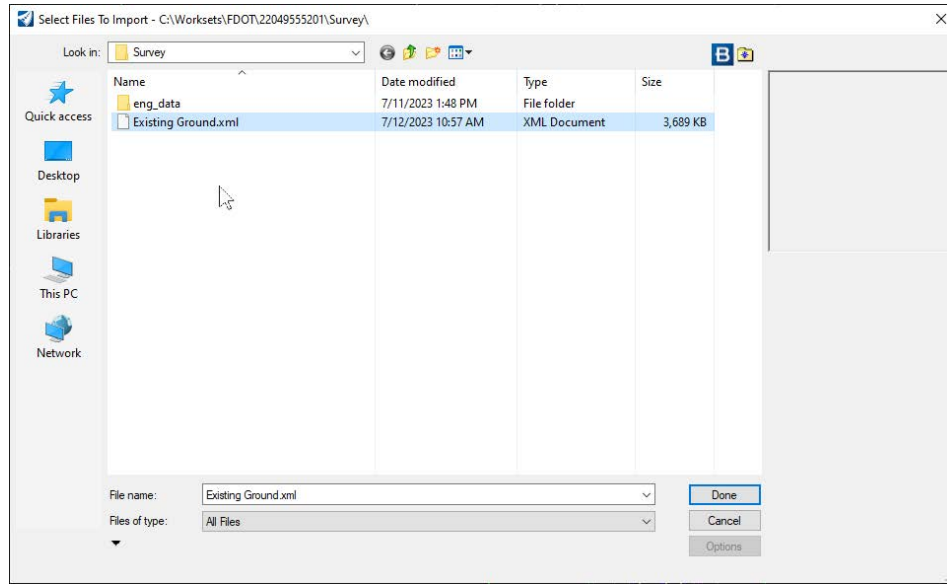

4. This will open the *Import Terrain Model(s)* dialog. Fill out the *File Options* with the information below, choosing **DtmExisting** for the *Feature Definition* and **FL83/2011-NF** for the *Geographical Coordinate Systems*. Click **Import** and close the dialog. Fit the view to see the imported *Existing Ground* terrain.

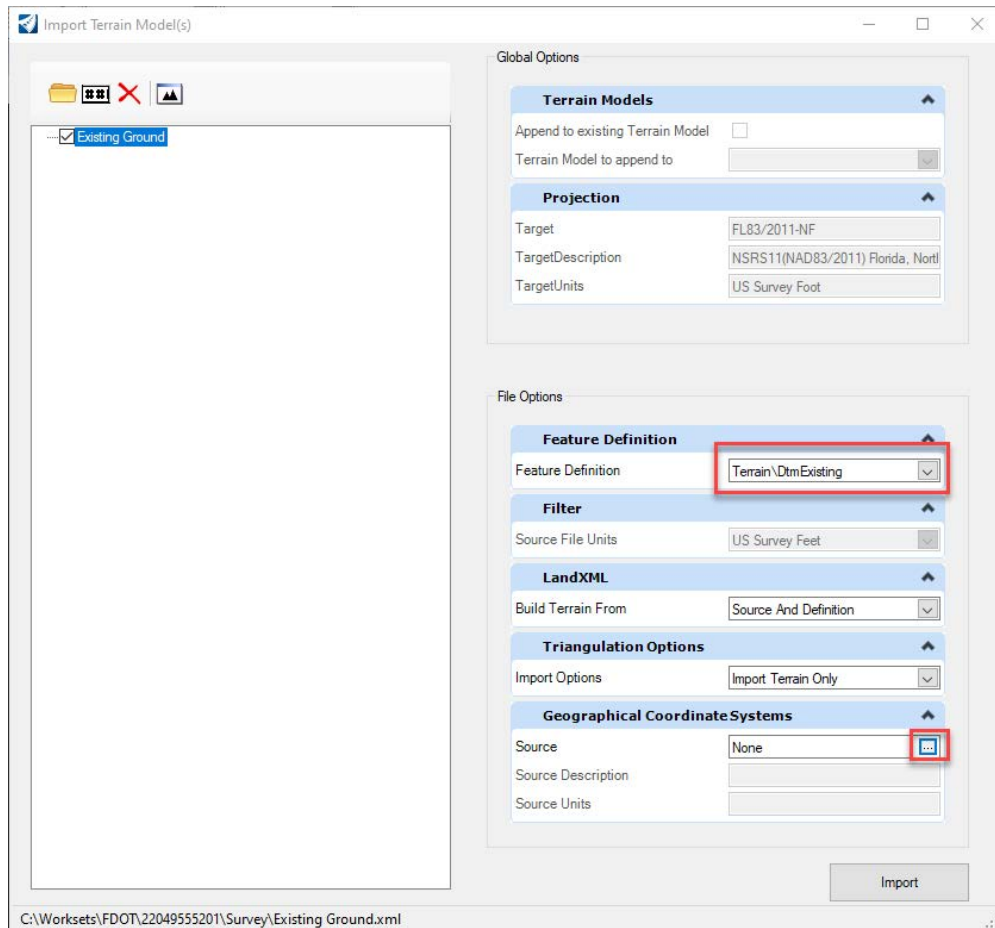

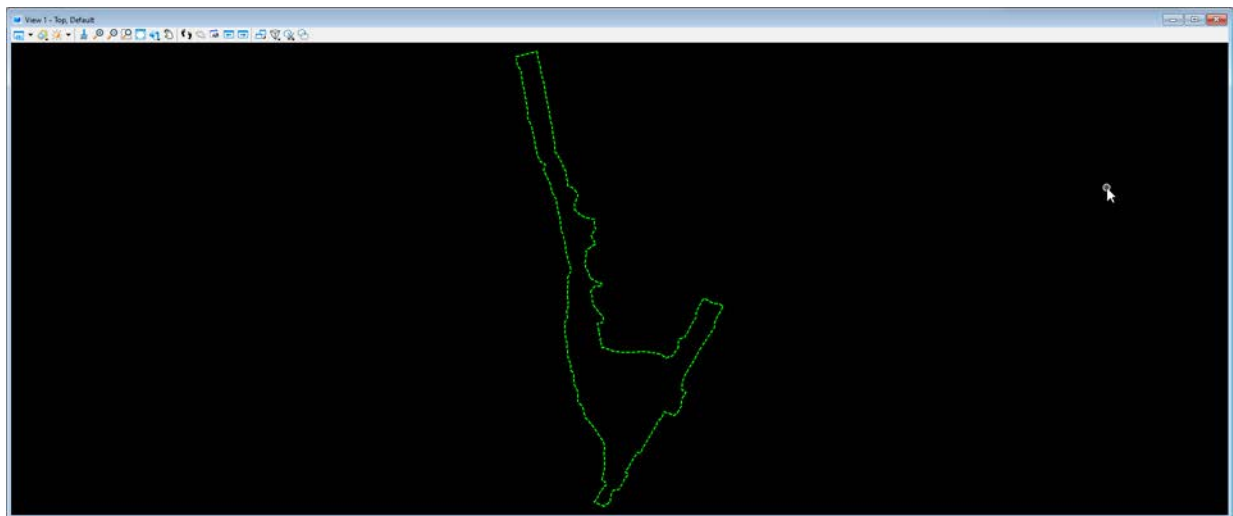
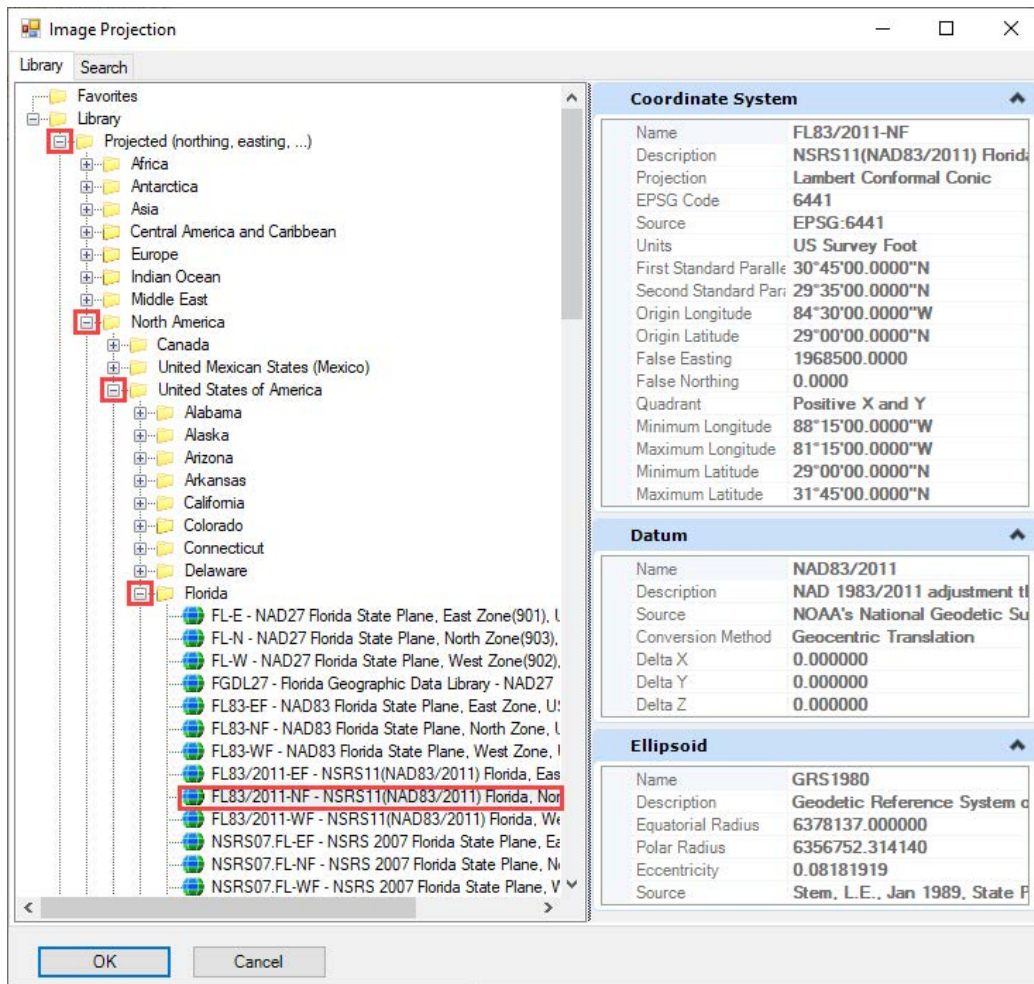

Exercise 1.3 (Optional) Creating a Complex Terrain

Creating a Complex Terrain allows you to bring together multiple existing ground terrains into one, which is simpler to work with since the existing ground will often be the active terrain and changing the active terrain can break models and profiles. It also allows you to easily update the terrain in the future should survey information change. This makes it a useful tool even if only one terrain is added. Different terrains can be added or removed from the definition of a complex terrain at any time, changing the terrain that most of the project design will depend on without breaking any dependencies or requiring recreating any models or profiles.

*Create a Null Terrain

This portion of the exercise would not be necessary on a project with multiple existing ground terrain models. For projects like this training dataset with only one terrain model provided, a null terrain must be created that can act as a placeholder and allow for the creation of a complex terrain.

1. From the *Geometry* tab of the ribbon, select **Point** in the *Horizontal* group.

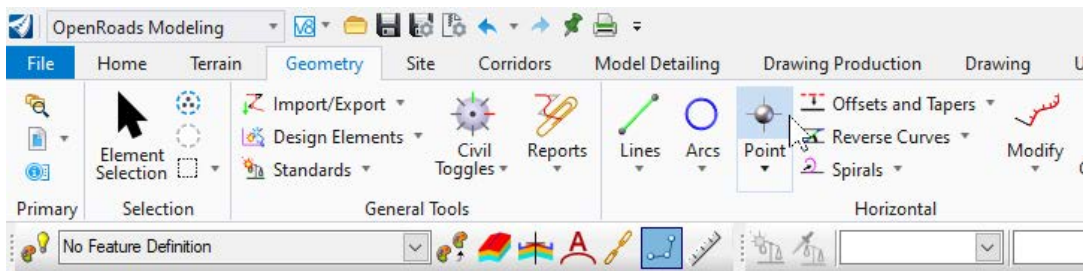

2. Match the values in the dialog below, and data point near the existing terrain to place the *Null Point*.

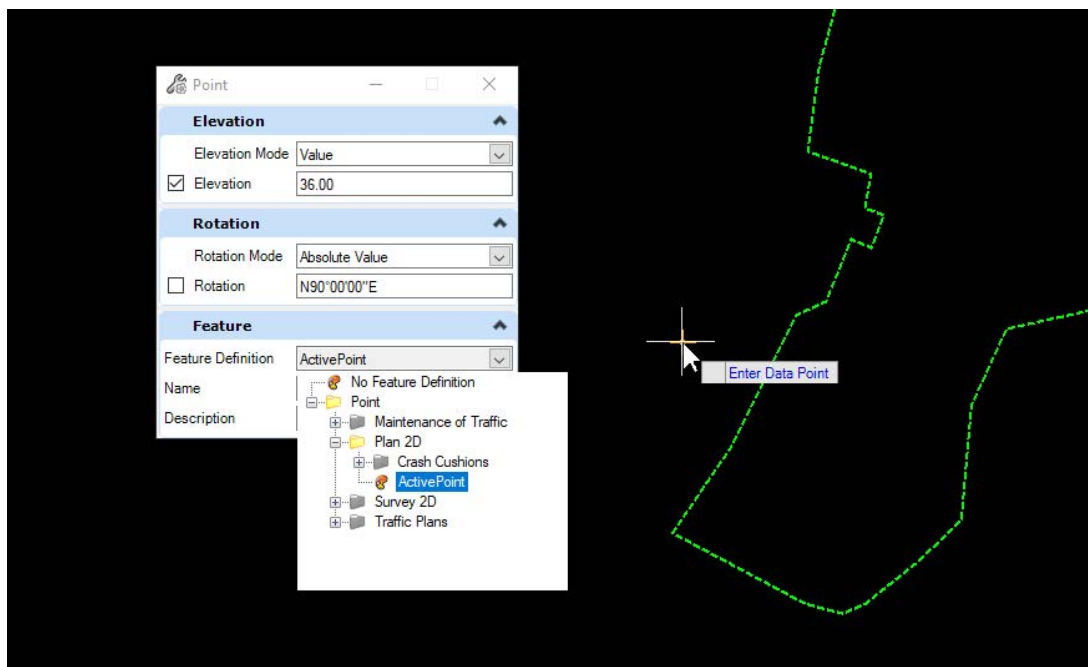

3. Navigate to the *Terrain* tab of the ribbon and select **From Elements** in the *Create* group. Fill out the dialog like below and select the *Null Point* that was just created. Accept all cursor prompts to create the terrain.

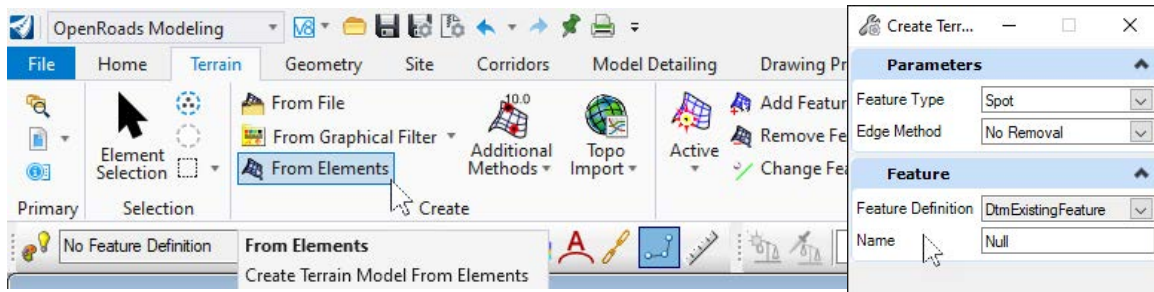

► **Create a Complex Terrain**

In the next steps we will append the *Null Terrain* to the *Existing Ground Terrain*, making a new *Complex Terrain*.

4. From the *Terrain* tab of the ribbon, select **Create Complex Terrain Model** located under the *Additional Methods* drop-down in the *Create* group.

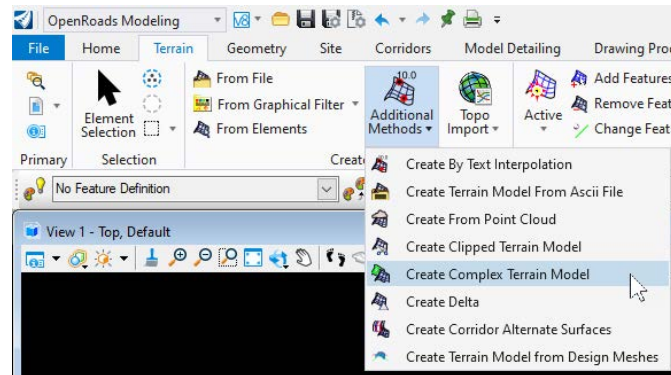

5. Set the *Current Action* to **Append** and add the *Existing Ground* terrain. Next, add the *Null* terrain. Select **DtmExisting** as the *Feature Definition* and give it the *Name Existing Ground Complex*. Click **Finish**.

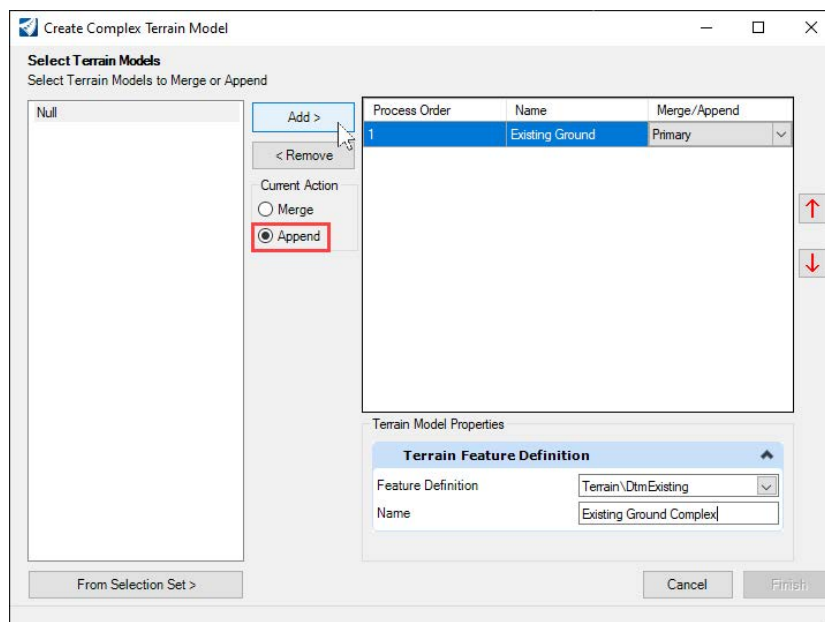

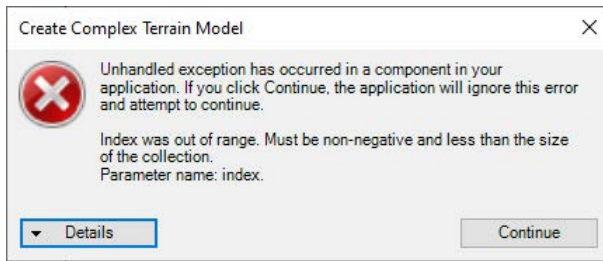

NOTE *OpenRoads may give an unhandled exception somewhere around this point. You can click continue and create the Complex Terrain. "Merge" discards information from the primary terrain model when terrains overlap. "Append" keeps points from both terrains. In this case, we created our null terrain from and keep information from our Existing Ground terrain, but this won't work unless the Existing Ground is primary. This shouldn't make a difference if there is no overlap between terrains*

If the *Complex Terrain* needs to be edited, navigate to it in **Explorer** under **OpenRoads Model > Terrain Models** and right click to choose **Edit Complex Terrain Model**.

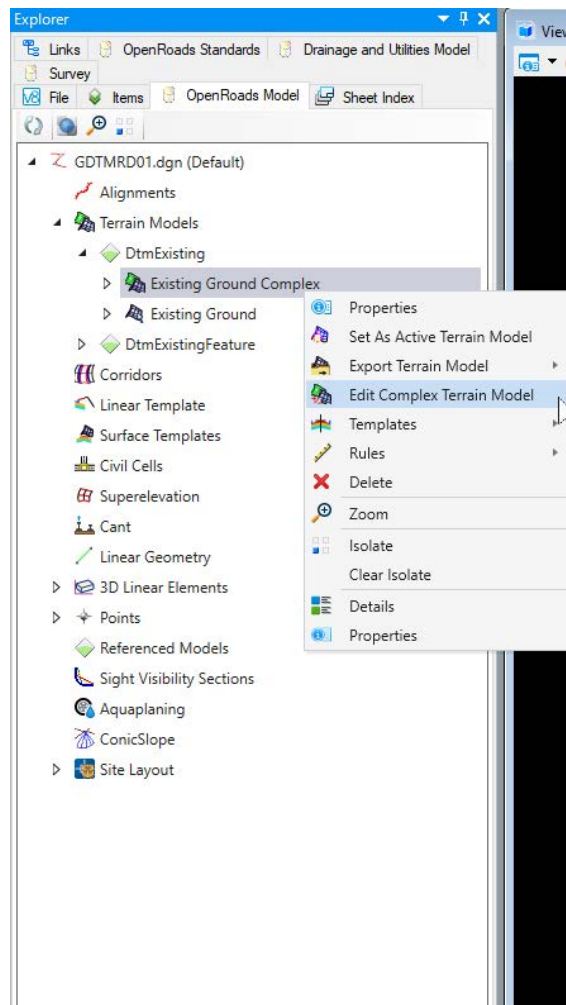
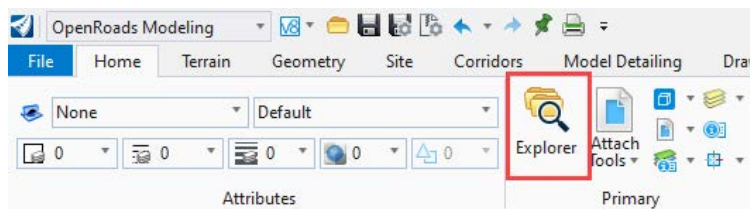

*Add a Boundary

The complex terrain will likely triangulate beyond the boundaries of the original existing ground. In the case of a project that has multiple disconnected terrains, this would be necessary to create one continuous terrain by triangulating between them. Designers must remember not to rely on any elevation information from the complex terrain in these areas with extra triangulation. In this case, we can add a boundary to get the terrain to match the original.

6. On the *Terrain* tab of the ribbon, select **Add Boundary** under *Boundary Options* in the *Edit* group.

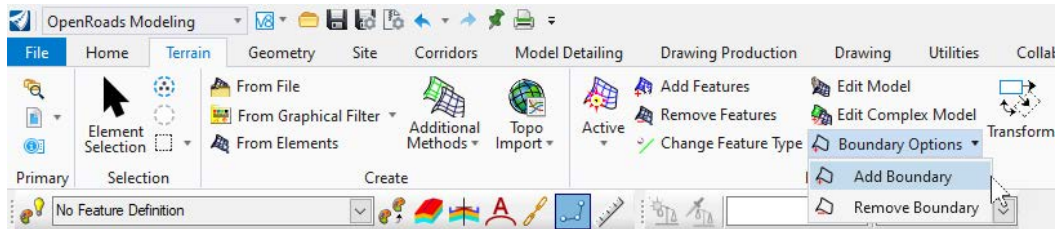

7. Set the *Method* to **Extract Graphic**. Set the *Feature Definition* to **Const Lines Red**. Set the *Name* to **Original Existing Ground Boundary**. Select the **Existing Ground** terrain and accept all cursor prompts to create a line string for use as the boundary.

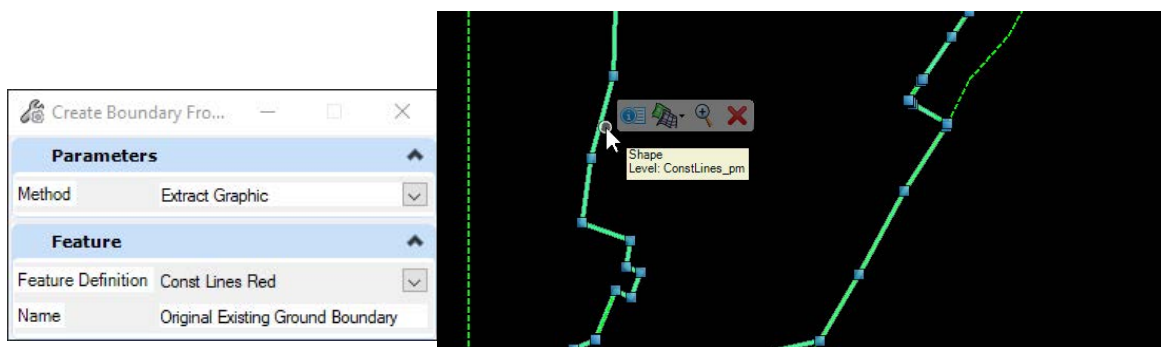

8. On the *Terrain* tab of the ribbon, select **Add Features** in the *Edit* group.

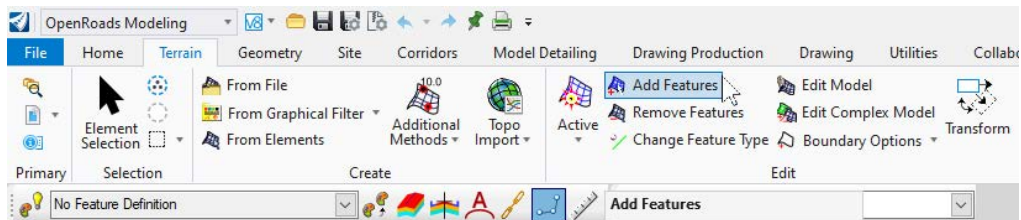

9. For the *Terrain Model* choose **Existing Ground Complex**. For the *Feature Type* choose **Boundary**. Select the boundary shape and accept the cursor prompts to complete this exercise.

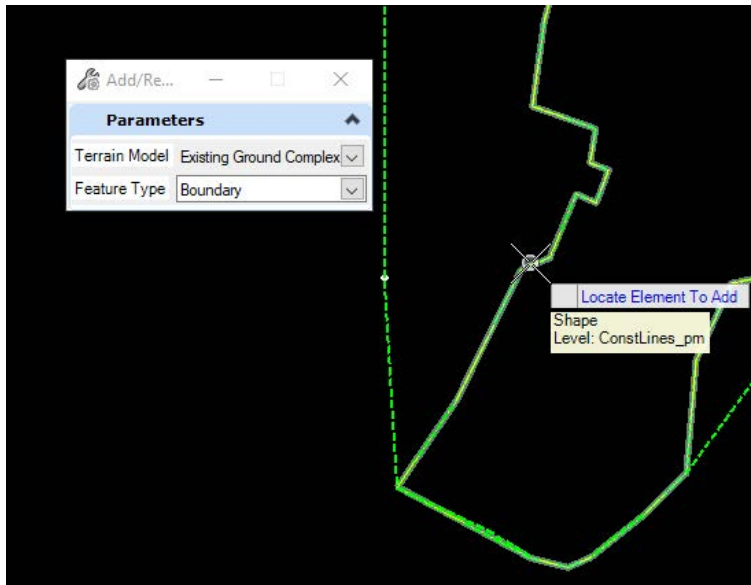

NOTE *Once the Complex Terrain is created it can be used in any file that needs the Existing Ground set as the Active Terrain.*

2 EXISTING FEATURES

INTRODUCTION

This chapter will introduce the OpenRoads Technology tools to use for viewing the existing terrain and creating 3D existing features in design models in FDOTConnect10.12. With the requirement to sign and seal backup calculations for earthwork, as well as more widespread use of the AMG (Automated Machine Guidance) by contractors, it is critical to create backup calculations (i.e., LandXML surfaces) for earthwork that closely match the cut/fill volumes. Since contractor software cannot take in meshes, but only terrains, the terrains need to match meshes as closely as possible.

CIVIL TERRAIN MODELING

As defined in the Bentley Civil Tools help files:

A terrain model is a set of three-dimensional triangles mathematically computed from point data collected on the surface being modeled. Models are used to define highly irregular surfaces, particularly the surface of the earth, but can be generated for proposed surfaces, subsurface geotechnical layers, and etcetera. Terrain models are also referred to as digital terrain models (DTMs), triangulated irregular networks (TINs), or triangulated surfaces.

The MicroStation Terrain Model tools support importing and labeling terrain contours and spots on terrain models. You can import a terrain model into a DGN to use its data. Terrain models imported from the LandXML file format are supported within MicroStation. However, any manipulation or importing from Civil products must be done within Bentley Civil.

Bentley Civil provides a robust set of tools to create, edit, analyze, and work with terrain models.

A terrain model is recognized as a MicroStation element type. When you select a terrain model, the Element Selection tool Element Type tab indicates that it is a Terrain element type.

Several terrain model civil features have been developed for the FDOTConnect10.12 Workspace to be used on FDOT projects. Terrain elements created in the design file can be selected from these features in the various terrain model tasks.

WORKFLOW INFORMATION

Existing features will be created in a 3D model following the steps outlined in the exercises to follow. When finished, the file will contain 3D existing features developed from the original existing DTM terrain and SURVRD01 files. As a result of creating this file, any cross section created while the terrain elements are displayed in the 3D model will show existing features below the surface.

EXERCISE OVERVIEW

Exercise 2.1	Create and set up a ALGNRD file.....	18
Exercise 2.2	Create and set up a MODLRD_Existing Features file.....	22
Exercise 2.3	Create Existing Feature Shapes.....	24
Exercise 2.4	Create Existing Feature Terrains (External).....	27
Exercise 2.5	(Optional) Creating a 3D Terrain Model Boundary by Active Profile.....	29
Exercise 2.6	Clip Internal Terrains.....	31
Exercise 2.7	Apply Surface Templates.....	33
Exercise 2.8	Edit Existing Feature Depth.....	35
Exercise 2.9	Add Curbs to the Existing Features.....	37
Exercise 2.10	View Existing Cross Sections.....	43

Exercise 2.1 Create and set up a ALGNRD file

1. The first step to set up an alignment file is to export geometry from the *SURVRD* file. Open the file *SURVRD01.dgn* from the *Survey* folder of the **22049555201** WorkSet.
2. On the *Home* tab of the ribbon, open the **Level Display** from the *Primary* group and turn off all levels except **BaselineSurvey**.

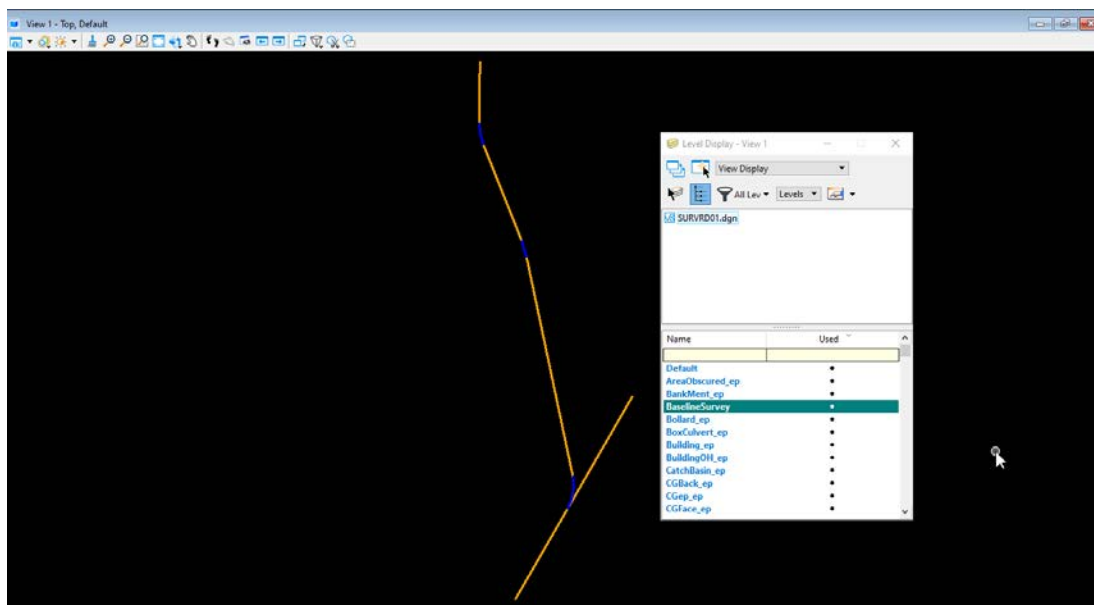
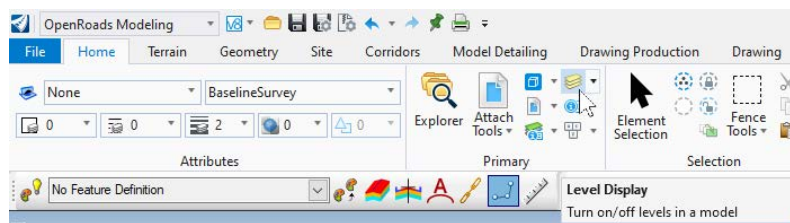

3. Navigate to the *Geometry* tab of the ribbon and select **Export Geometry** from the *Import/Export* drop-down in the *General Tools* group. Match the settings in the dialog below and select each Baseline **SR61 & US98**. Accept all options and a prompt will appear asking for a location to save the .xml file. Name this .xml file *Alignments.xml* and save it to the *Roadway* folder.

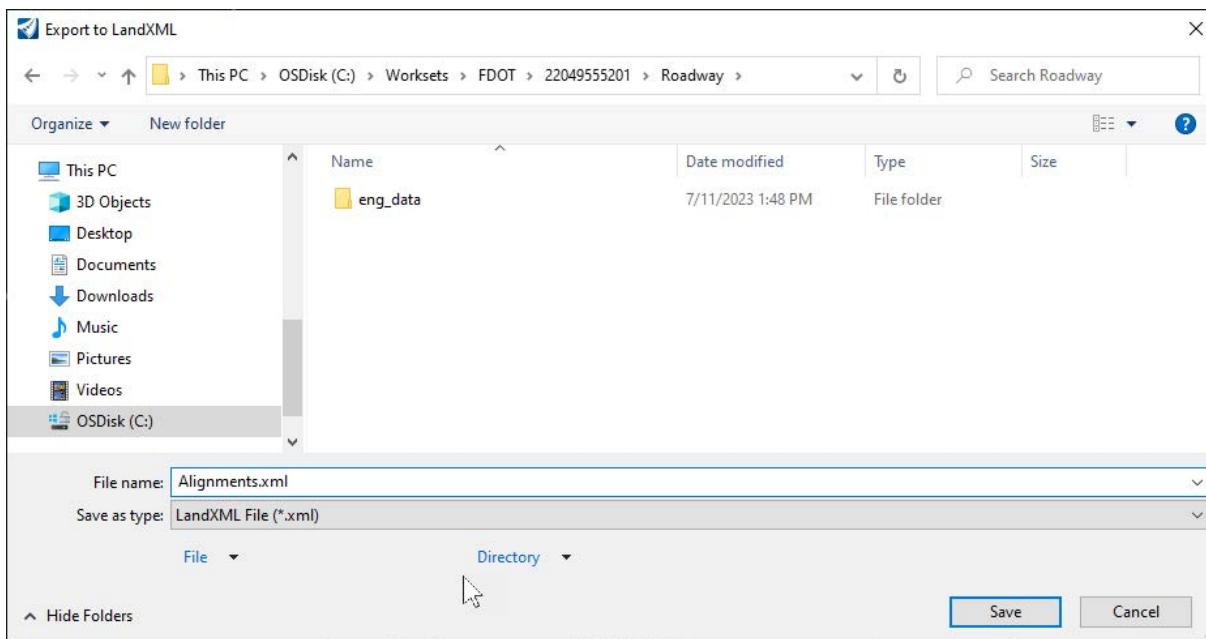
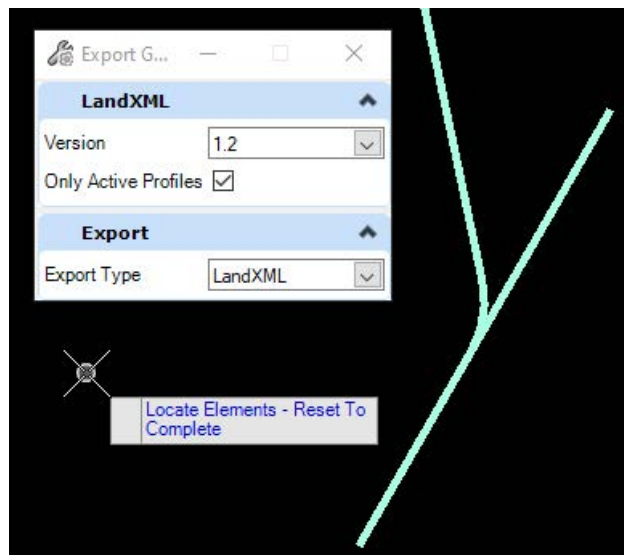
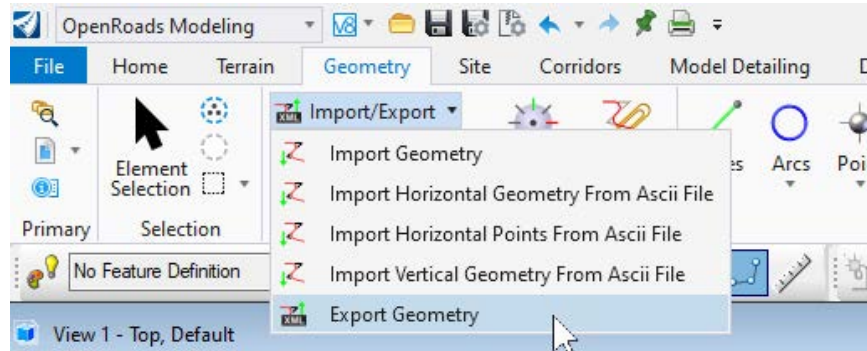

- Launch the **Create File** tool from the *FDOT* tab of the ribbon in the *Actions* group. Switch the *Discipline* to **Roadway** and the *File Group* to **Roadway Design Files**. Select the *Base Filename* **ALGNRD** from the list. Select a **Coordinate System** for the file or select a **County** which automatically populates the coordinate system dropdown. Make sure all settings match the dialog below, and then click **Create - Open File**. Close the **Create File** tool.

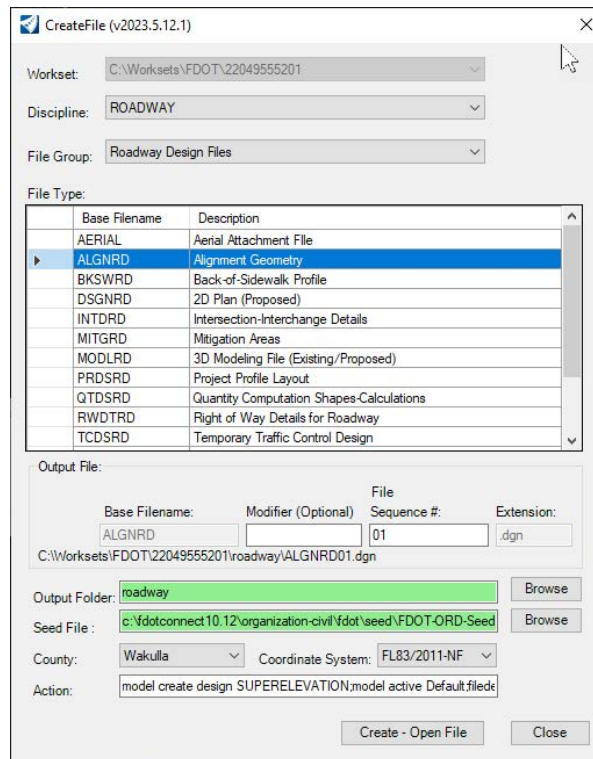

- On the *Geometry* tab of the ribbon select **Import Geometry** from the *Import/Export* drop-down under the *General Tools* group. Choose the *Alignments.xml* file located in the *Roadway* folder and click **Open**.

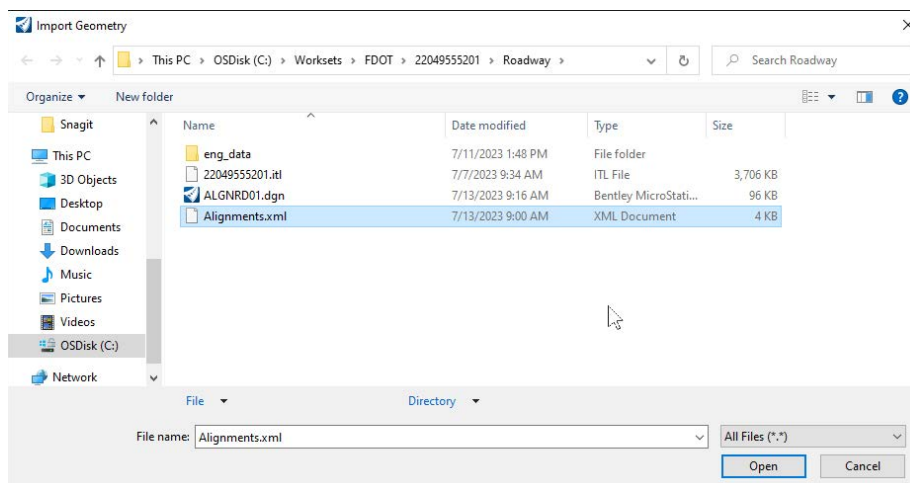
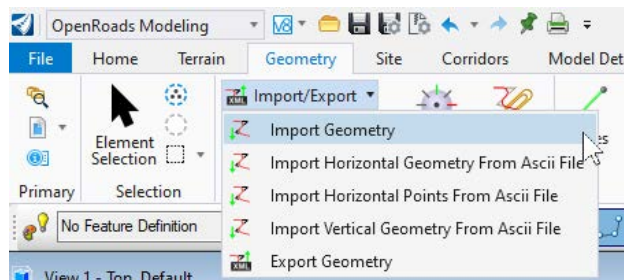

6. On the *Import Geometry* dialog tick the box next to **Alignment** then click **Import**. Use the **Fit View** tool located on the top of the view window to bring the imported elements into view. These alignments will be used later to view dynamic cross sections.

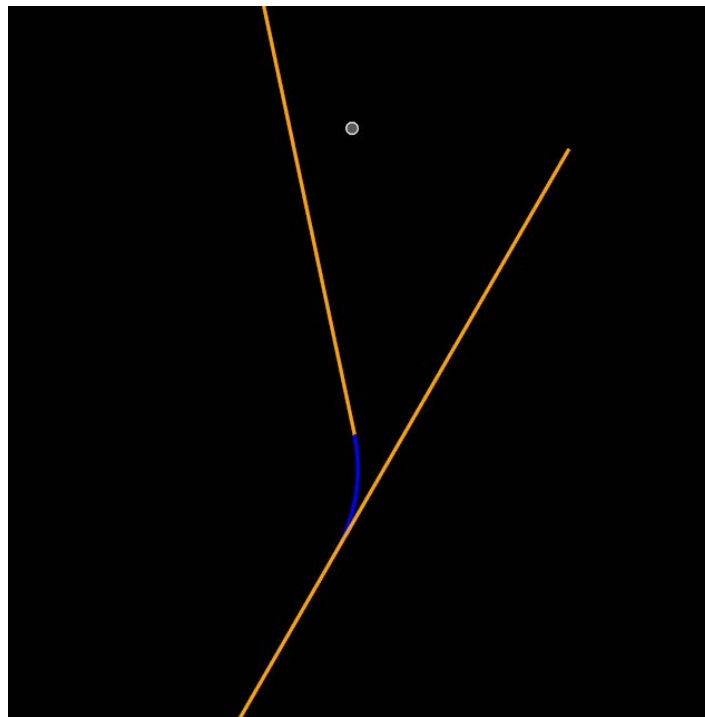
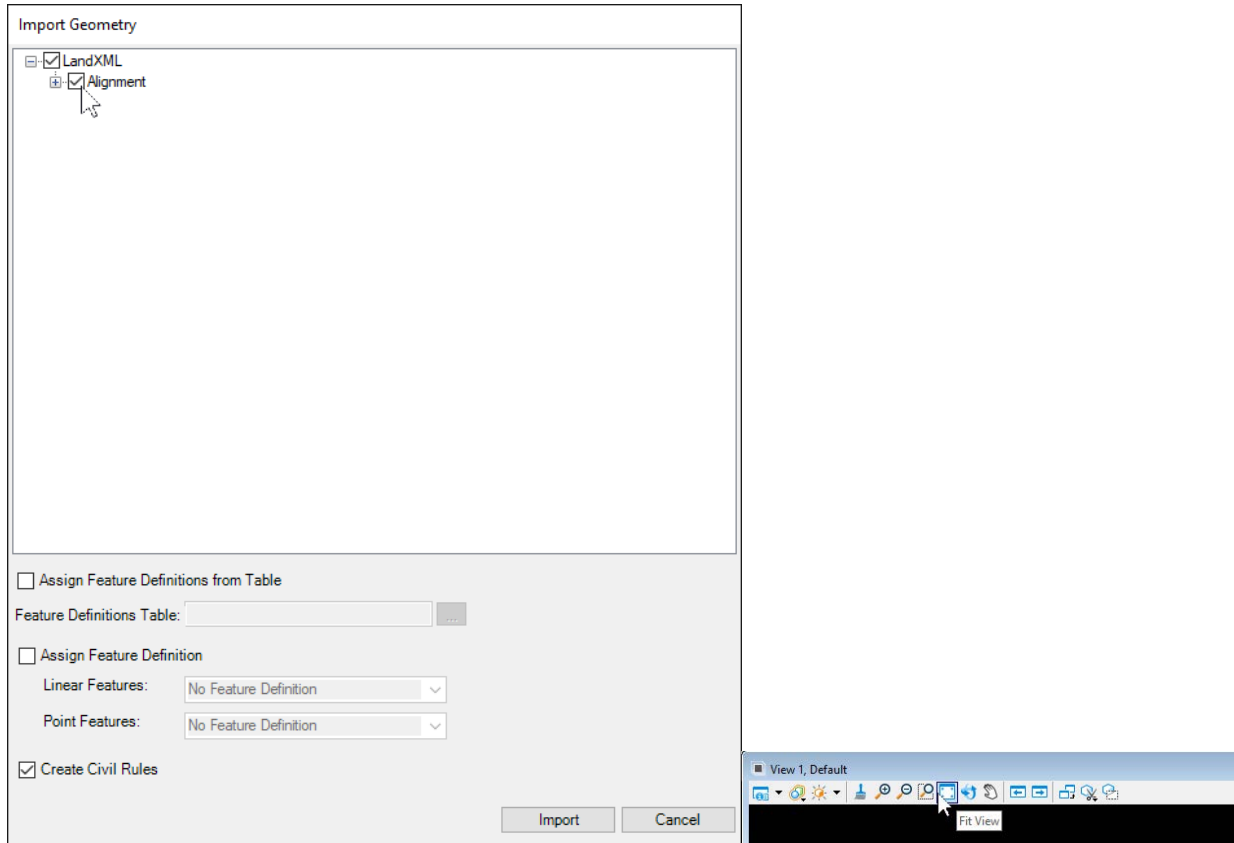

Exercise 2.2 Create and set up a MODLRD_ExistingFeatures file

1. Launch the **Create File** tool from the *FDOT* tab of the ribbon in the *Actions* group. Switch the *Discipline* to **Roadway** and the *File Group* to **Roadway Design Files**. Select the *Base Filename* **MODLRD** from the list. In the *Modifier (Optional)* field, type **_ExistingFeatures**. Select a **Coordinate System** for the file or select a **County** which automatically populates the coordinate system dropdown. Make sure all settings match the dialog below, and then click **Create - Open File**. Close the **Create File** tool.

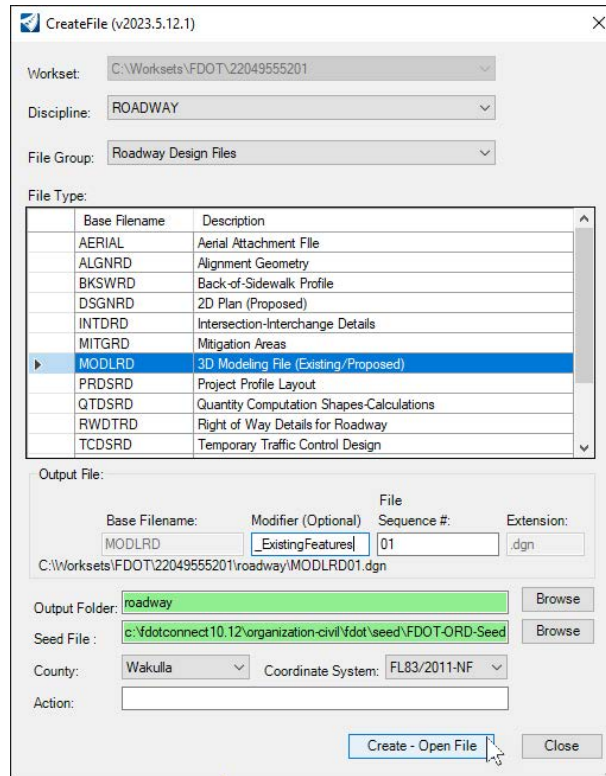

2. From the *FDOT* tab of the ribbon, select the **Create Existing Features** button under the *Roadway* group. A prompt will pop up asking to attach a survey .dgn file, click **OK** and select the file **SURVRD01.dgn** from the project *Survey* folder and click **Open**

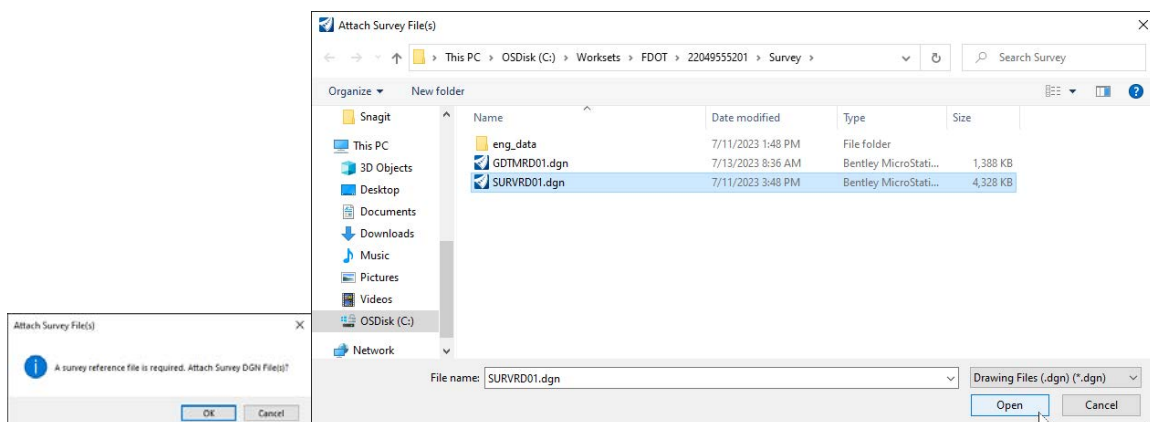
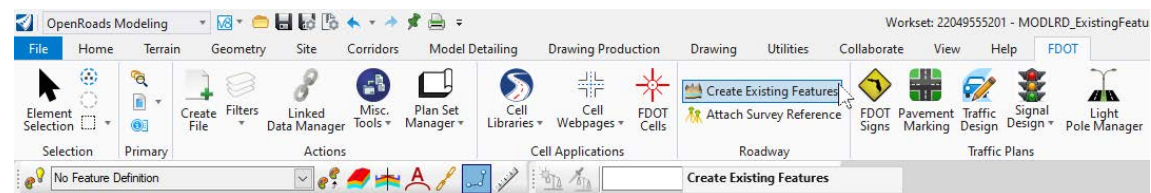

The FDOT Features tool attaches the survey file as a reference and copies elements required for existing features into the current file.

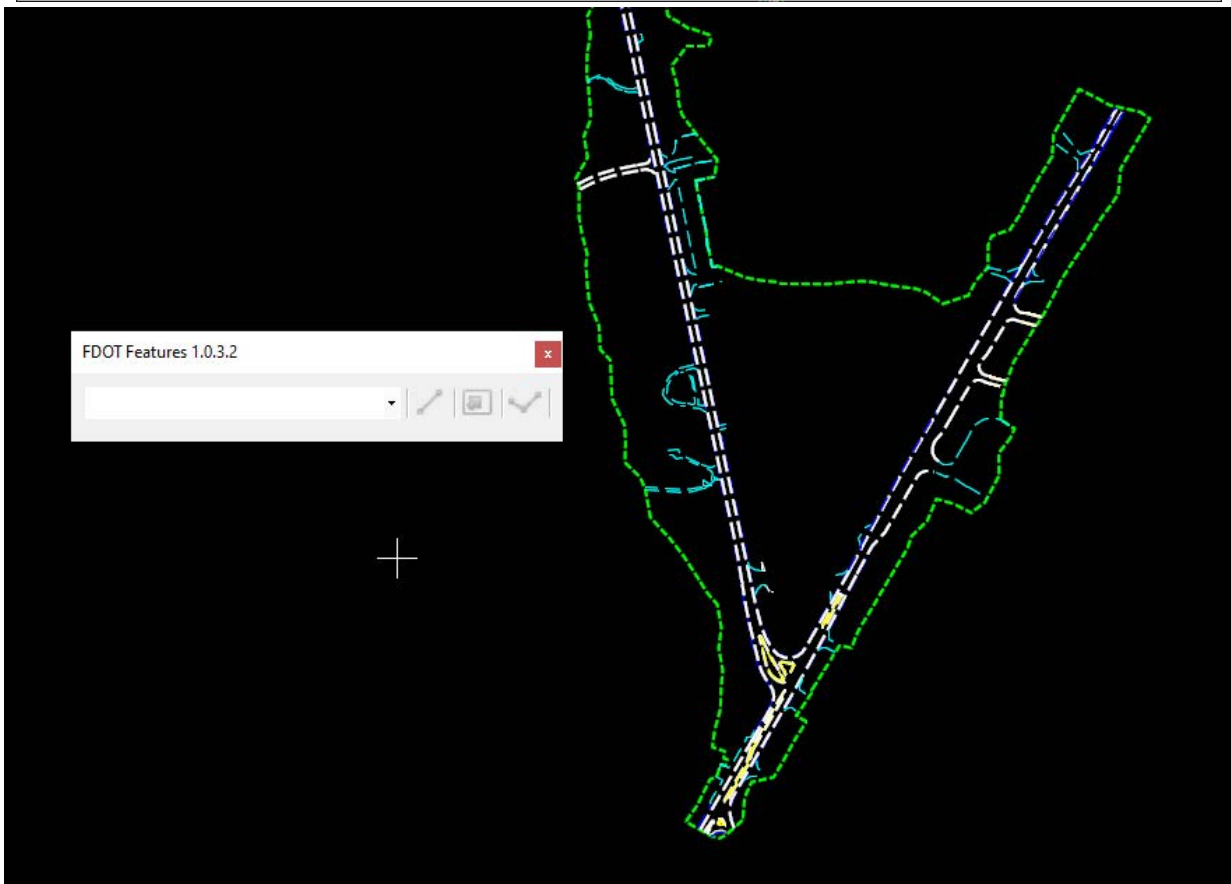
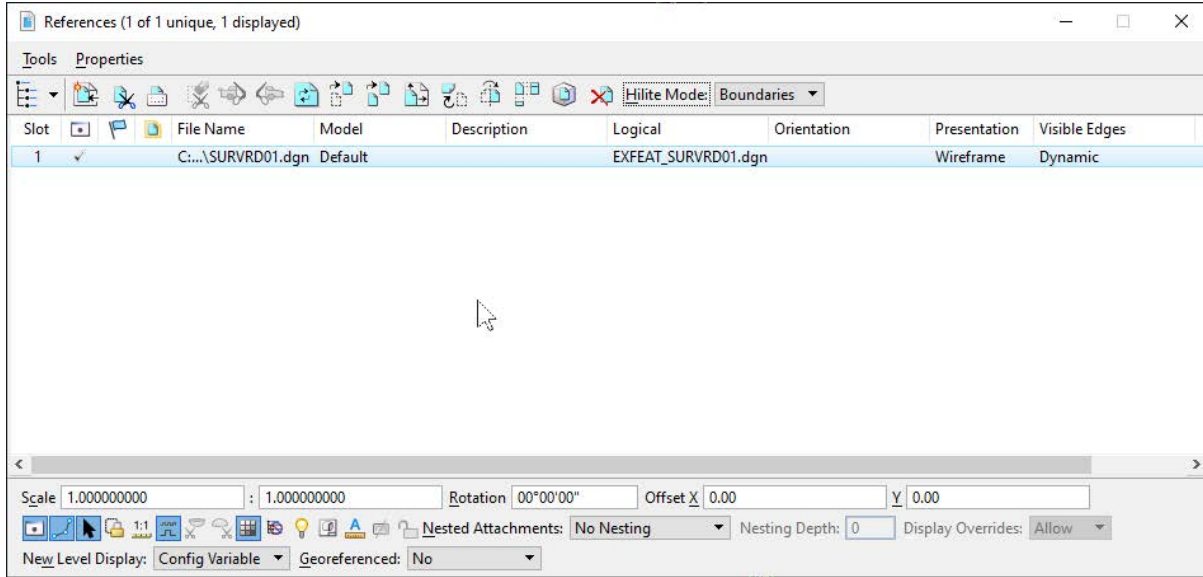

Exercise 2.3 Create Existing Feature Shapes

The **FDOT Features** tool will assist in creating closed shapes to clip out terrains. From left to right the tool contains a drop-down menu to select the *Existing Feature*, a *Place Feature Line* tool, a *Create Feature Shape by Flood* tool, and a *Create Feature Shape by Trace* tool.

1. In the drop-down list of the **FDOT Features** tool, select **Pavement**. Notice that the tool automatically isolates the **PavtAsphalt_ep** level in the view.

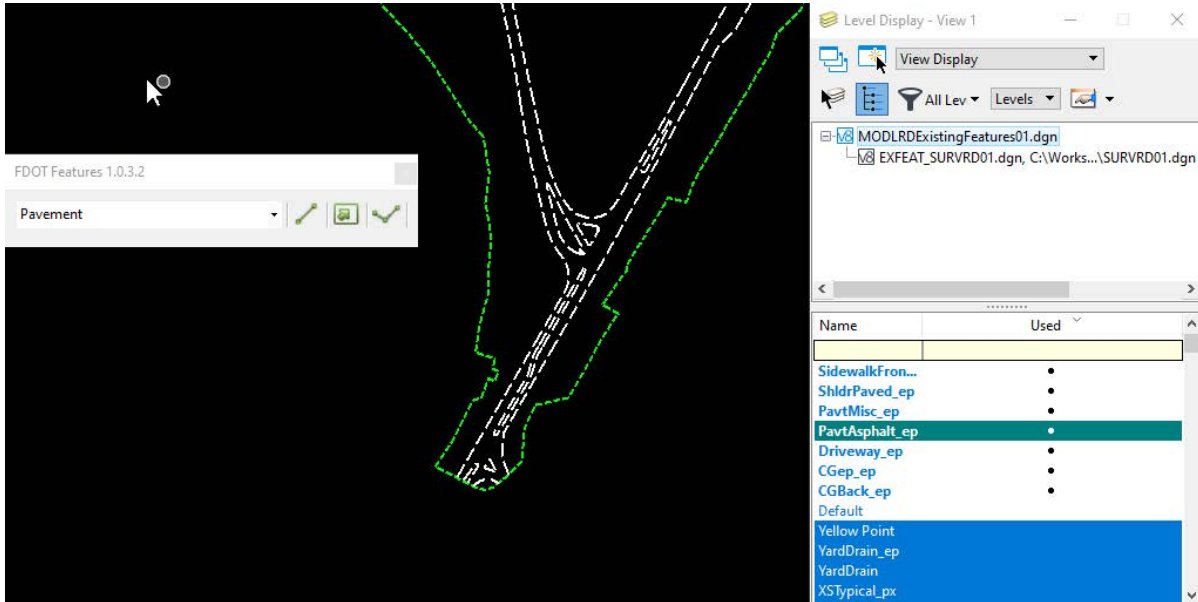

2. Use the Place Feature Line tool to draw lines delineating the side streets to the northeast as well as closing off other ends of the US98 mainline. For areas that have curves, a tangent snap helps to keep the linework from crossing over each other.

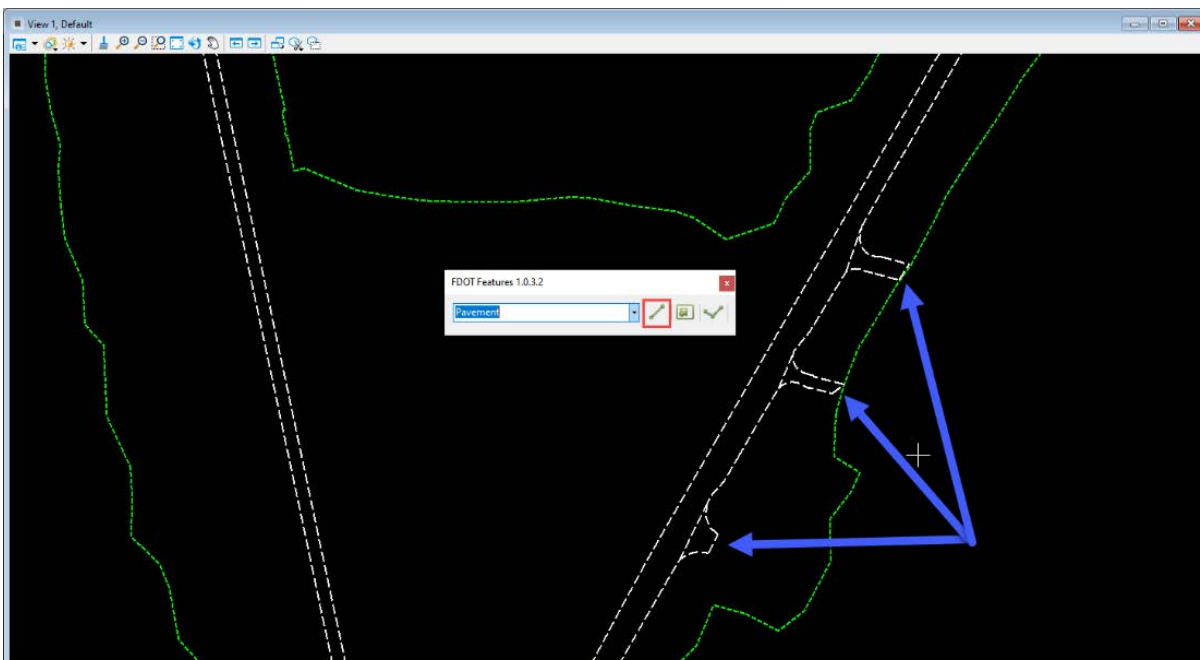



- Using the **Create Feature Shape by Flood** tool, click inside of the closed roadway mainline. The tool will highlight the shape and fit to view. Click in the view to accept and create the shape. the shape and fit to view. Click in the view to accept and create the shape.

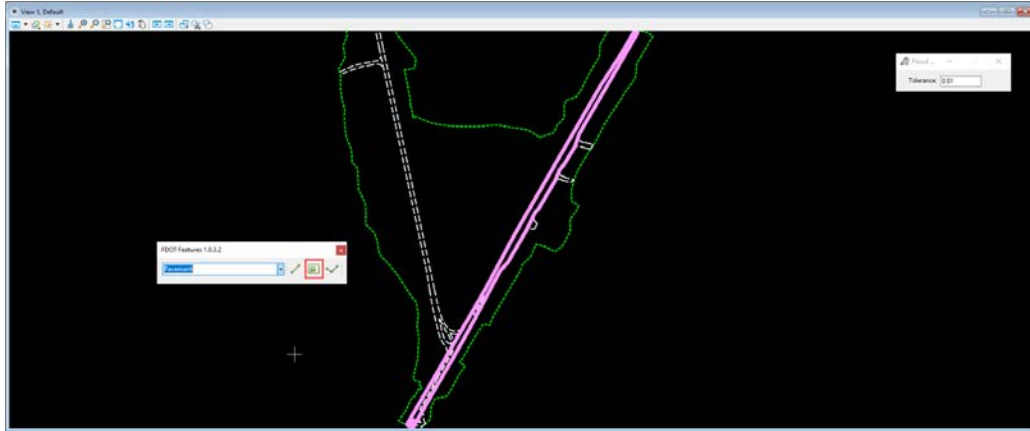

- Repeat steps 1-3 to create closed shapes for the remaining existing features:

Driveways, Medians/Traffic Separators, Shoulders, Side Streets

Curbs do not use a shape and are instead created using a linear template, which is shown in a later exercise. After all necessary clipping shapes have been created, **Close** the tool.

Exercise 2.4 Create Existing Feature Terrains (External)

Once closed shapes are created, they can be used to create individual external or internal terrains with clipping tools. *External terrains* are clipped from the existing ground, while *Internal terrains* are clipped from within *External terrains*. Only one shape at a time can be clipped while using the *External* method. Multiple shapes can be clipped when using the *Internal* method.

The following *Terrain* features are included to assist in creating existing features on a project:

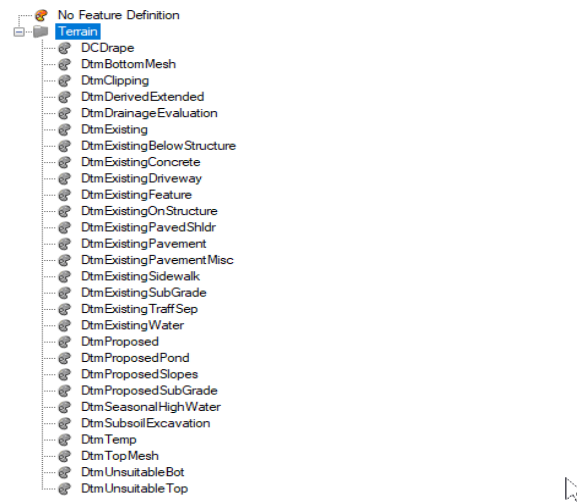

1. Continuing in the file **MODLRD_ExistingFeatures01**, detach the reference *SURVRD01.dgn*.
2. Attach the file *GDTMRD01.dgn* from the project *Survey* folder. Click on the **Existing Ground terrain element** to get the context menu and choose the second option, **Set As Active Terrain Model**. Key **Ctrl+F** to save settings.
3. In the *Default* view make **PavtAsphalt_ep** the *Active Level* and turn off all other levels.
4. On the *Terrain* tab of the ribbon select the **Create Clipped Terrain Model** tool under the *Additional Methods* drop-down in the *Create* group.

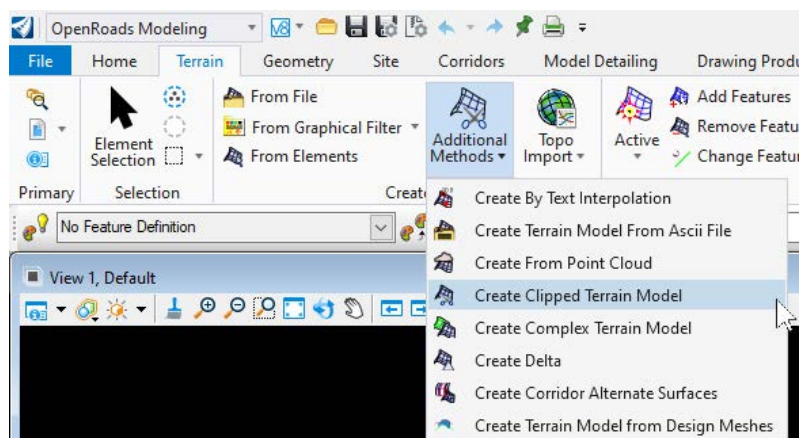

- Select the **Existing Ground** in the view as the *Reference Terrain Model Element*, change the *Clipping Method* to **External**, leave both *Offset* values at **0.00**, choose **DtmExistingPavement** as the *Feature Definition*, and give it the Name **US98_ExPavt_Temp**. Follow the *cursor prompt* to locate the **Clipping Element**, which is the mainline shape created in the previous exercise. Accept each cursor prompt to complete the command and create the clipped terrain. The terrain is created in the **Default-3D** model and referenced back to the **Default** model.

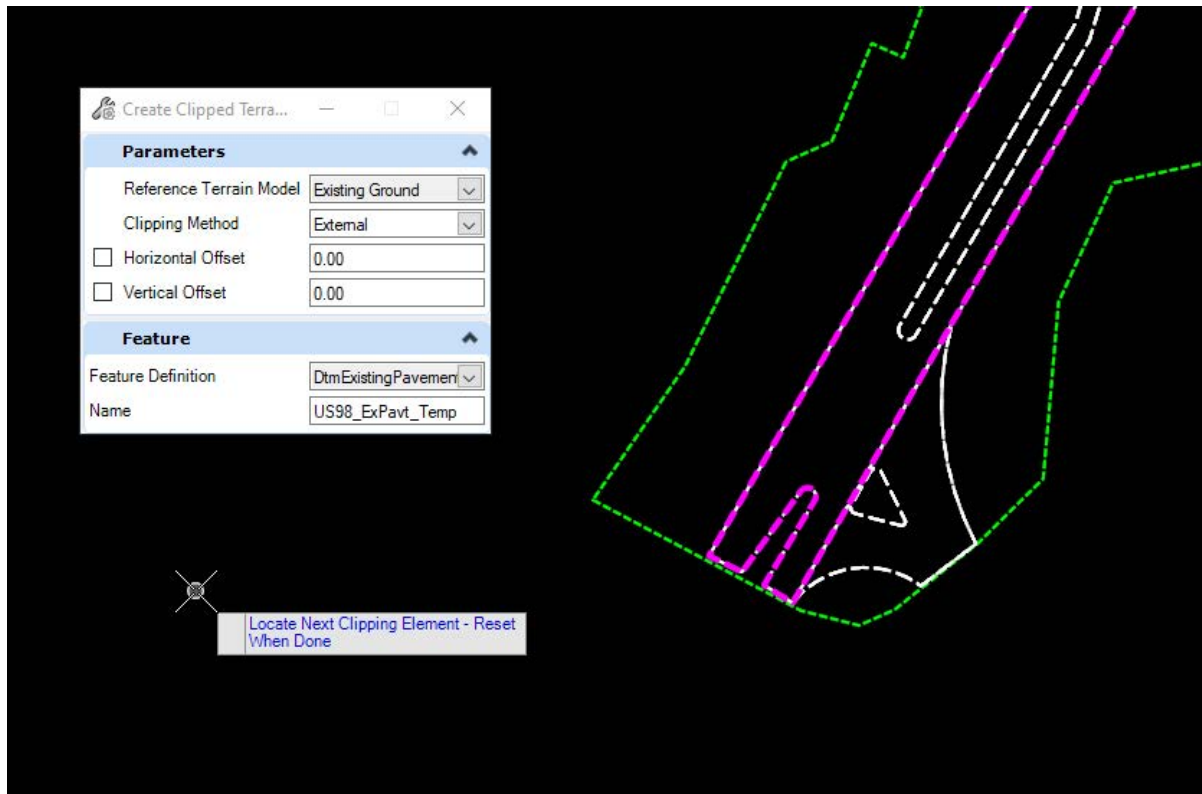

- Press the **F2** function key to open a plan view and 3D view side by side and view the resulting clipped terrain.



- Repeat steps 3-5 for the remaining existing feature shapes (i.e., *driveways, shoulders, medians/traffic separators, side streets*)

NOTE *External clipping of US98 traffic separator should be done after the Internal Terrain is created in Exercise 2.6*

Exercise 2.5 (Optional) Creating a 3D Terrain Model Boundary by Active Profile

This exercise covers what to do in the event a clipped terrain triangulates outside of the shape boundary.

1. Select the **Clipping Shape Boundary** of the problem terrain. On the context menu select **Open Profile Model**. Open **View 3** and click inside the window to display the profile of our shape. Select the profile and choose **Set As Active Profile**.

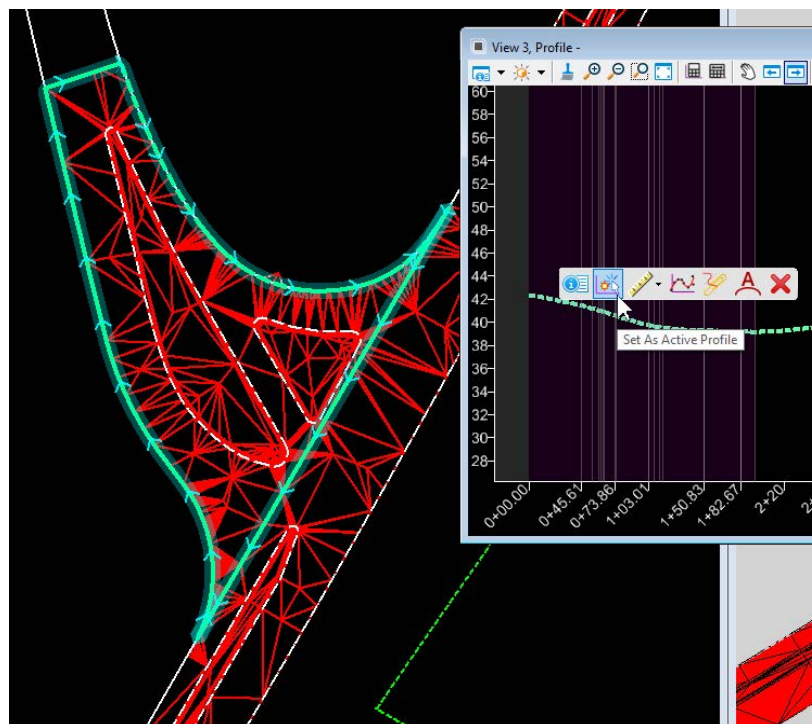
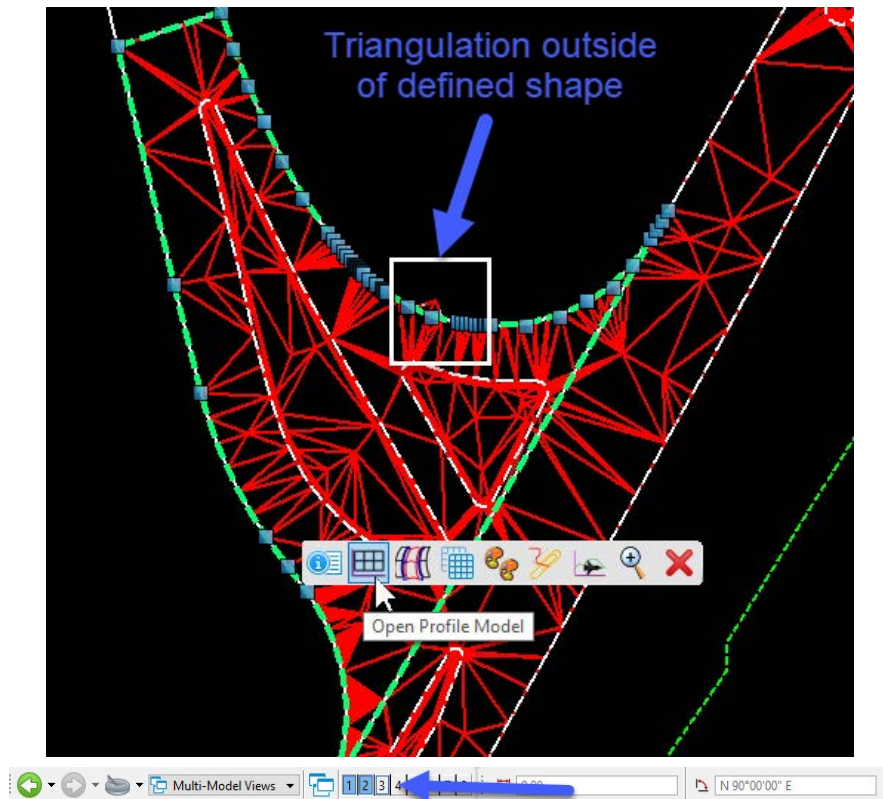

- From the *Terrain* tab on the ribbon, select the **Add Features** tool in the *Edit* group. Change the *Feature Type* to **Boundary**. In this example, **SR61_ExPavt_Temp** is used as the name of the *Terrain Model*. Select the profiled shape and accept the cursor prompts. The clipped terrain *Edge Method* changes to **From Boundary** and is constrained to our original shape.

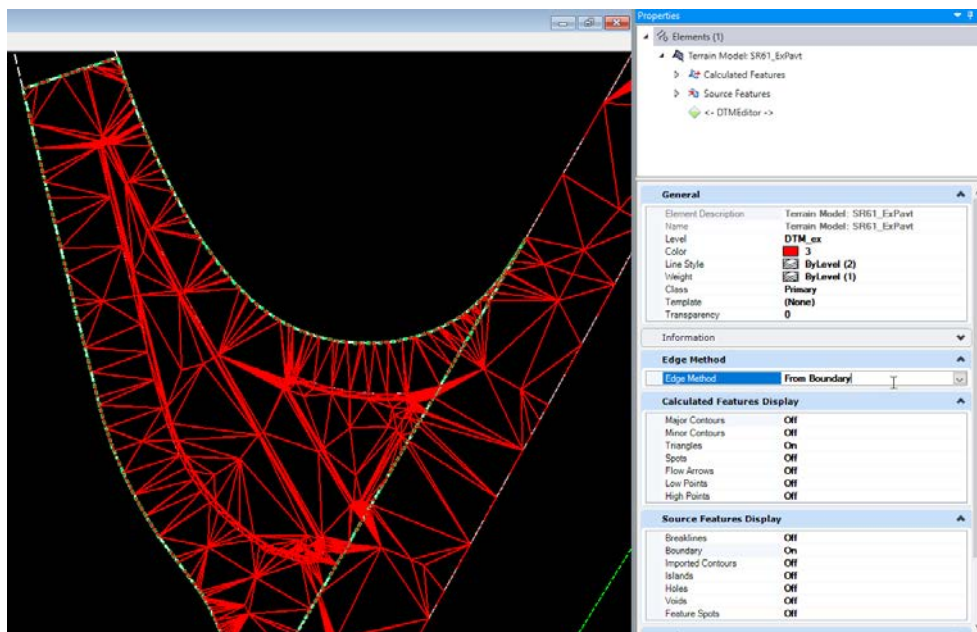
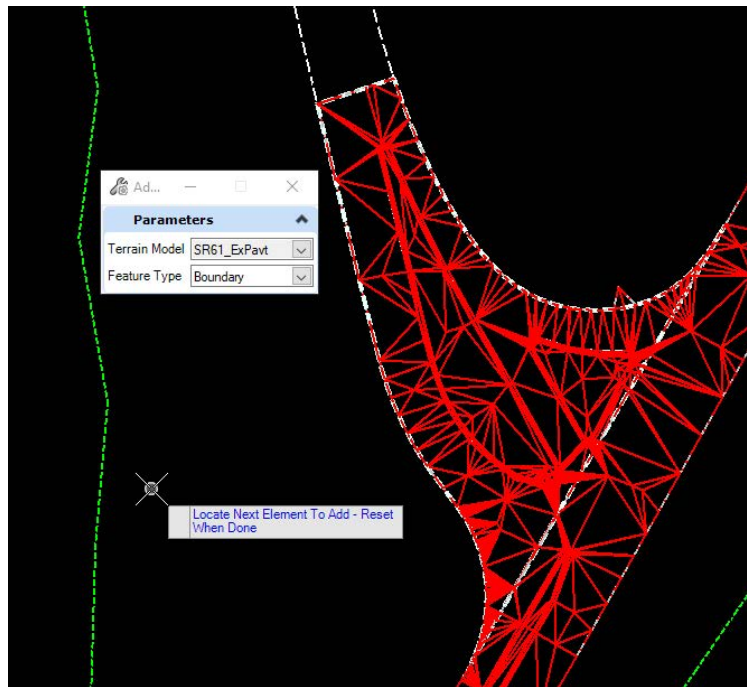
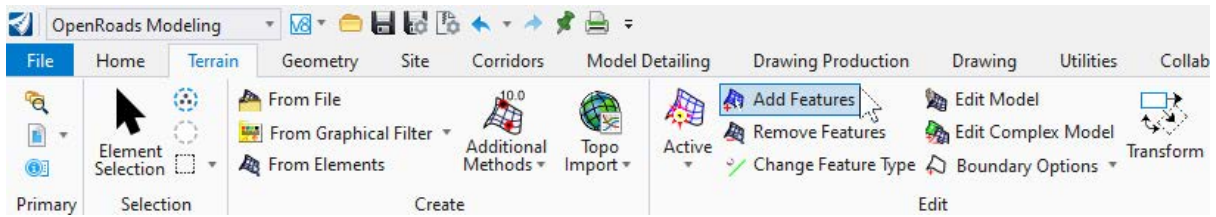

NOTE If the terrain isn't updating, select an option in the *Edge Method* drop-down. This will force it to lock to the boundary.

Exercise 2.6 Clip Internal Terrains

In some cases, the terrain created may include areas that they should not such as *Traffic Separators*, *Medians*, or *Curbed Islands* within a terrain created for a pavement area. These smaller sections need to be clipped out of the larger terrain. This is referred to as *Internal Clipping*. The tool creates a new terrain with the area clipped out, it does not modify the existing terrain or the original terrain. In the next exercise, features will be clipped out of the US98_Expavt_Temp terrain.

1. In the *Default* view, key **F9** to launch the **References** dialog and turn off the display of the reference *MODLRD_ExistingFeatures01.dgn*. Change the *Active Level* to **PavtAsphalt_ep** and turn off all other levels.

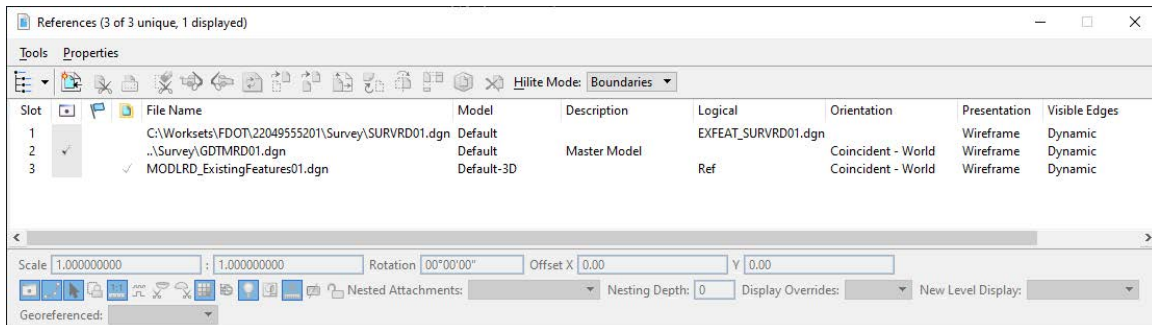

2. On the *Terrain* tab of the ribbon select the **Create Clipped Terrain Model** tool under the *Additional Methods* drop-down in the *Create* group.
3. For the *Reference Terrain Model* choose **US98_Expavt_Temp**, for the *Clipping Method* choose **Internal**, leave both *Offset* values at **0.00**, set the *Feature Definition* to **DtmExistingPavement**, and for the *Name* use **US98_Expavt**. Select the median and traffic separator shapes within the US98 pavement shape as highlighted below, then follow each cursor prompt to create the new terrain.

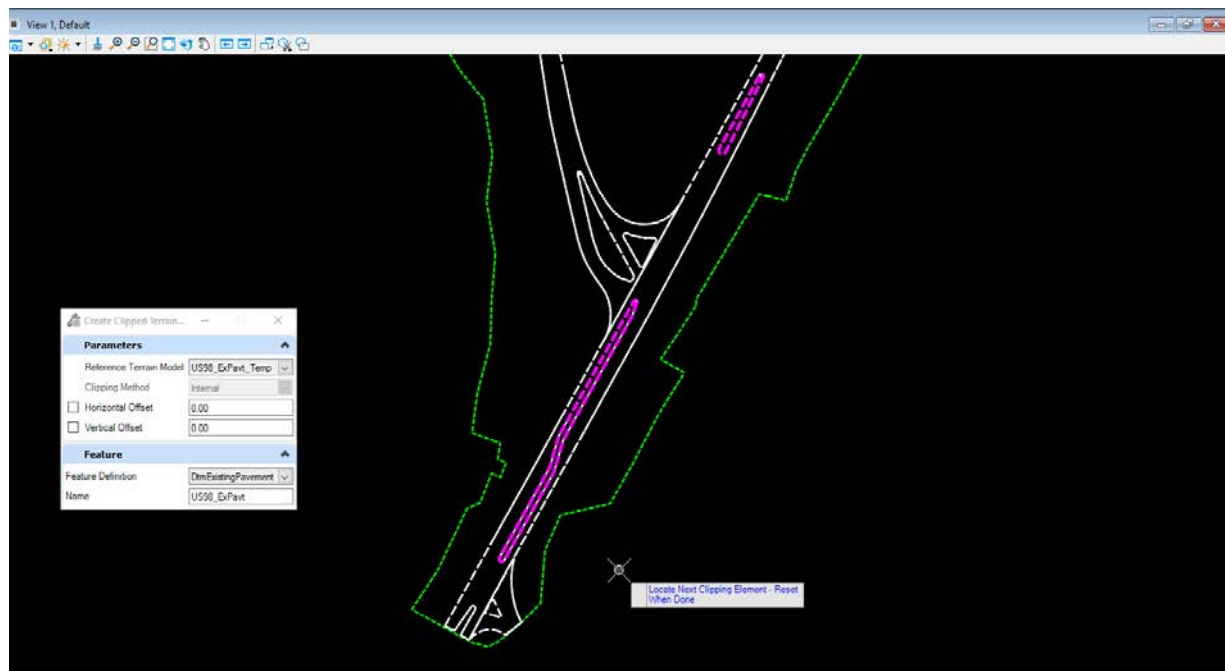

4. In the **Default-3D** view, select the **US98_ExPavt_Temp** and delete it. The terrain that is left: **US98_ExPavt**; should have punched out holes that match the internal clip shapes created previously.

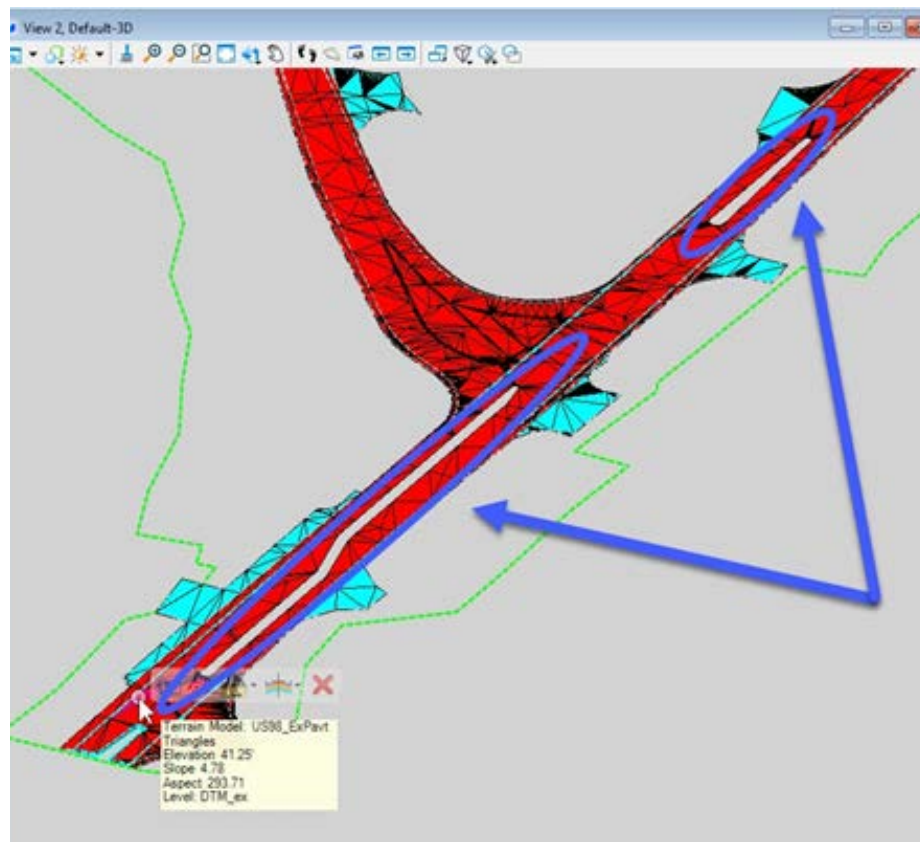
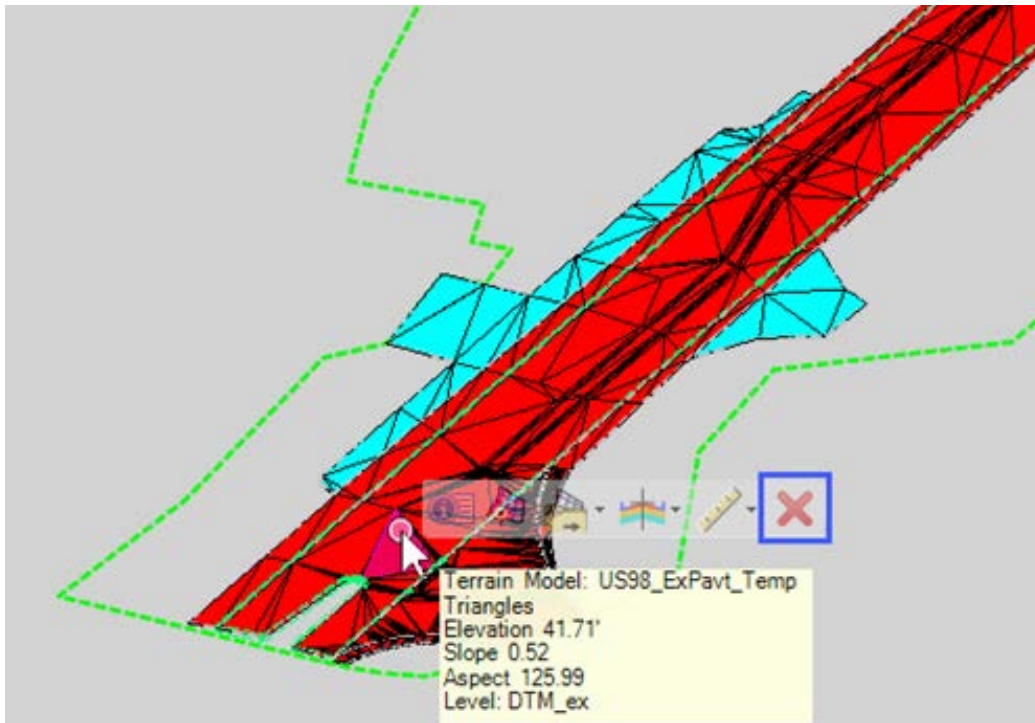

NOTE Alternatively, the external terrain can be deleted in Explorer from OpenRoads Model>Terrain Models. If using this method, it is important to keep track of what name you have given your terrain, so the Internal terrain remains.

5. Repeat steps 2-4 on the **SR61_ExPavt_Temp** terrain and any other terrains with internal shapes.

Exercise 2.7 Apply Surface Templates

In this exercise, a *Surface Template* will be applied to each of the existing terrains giving them depth.

1. Close the Default view and maximize the Default-3D view.
2. On the *Model Detailing* tab on the ribbon, select the **Apply Surface Template** tool under the *Surface Templates* drop-down in the *3D Tools* group. For the *Template*, click the **Ellipsis** button to open the *Pick Template* dialog. Under *Existing Feature Templates*, select **PavementAsphaltExisting** and click **OK**. Leave the *Feature* properties as is.

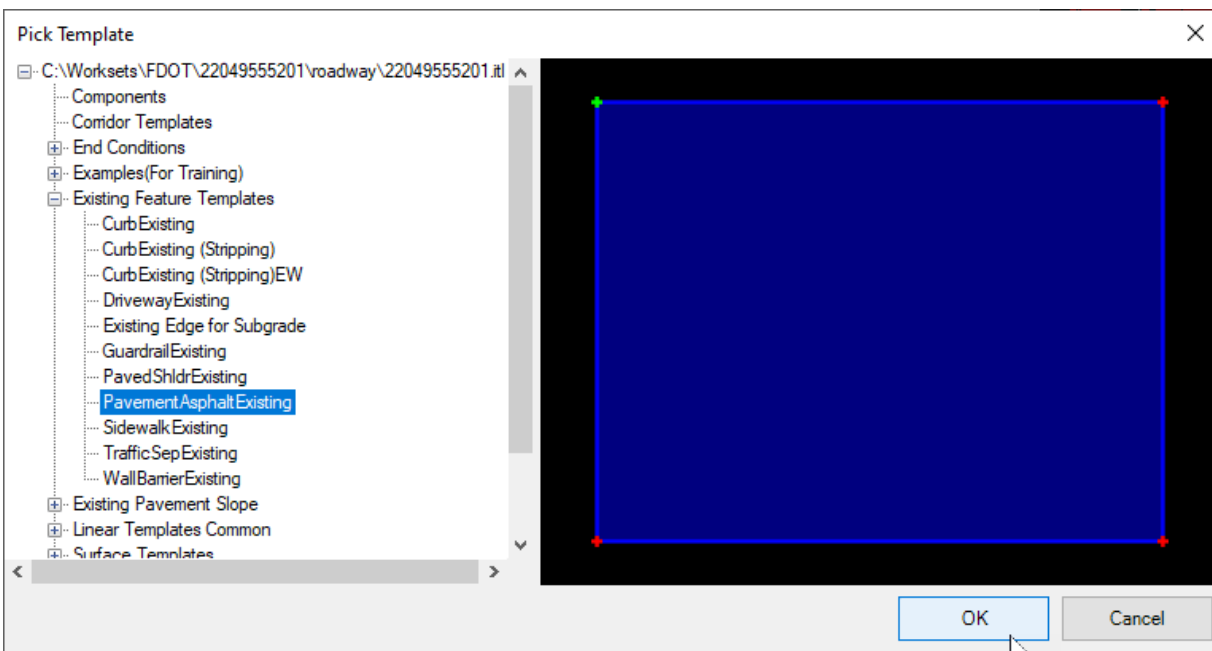
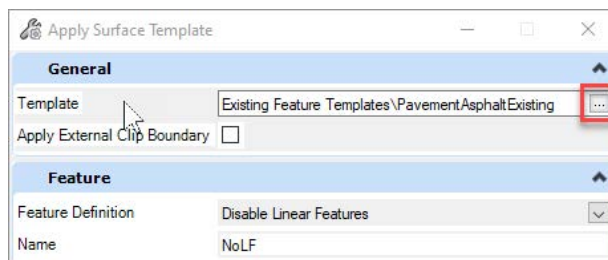
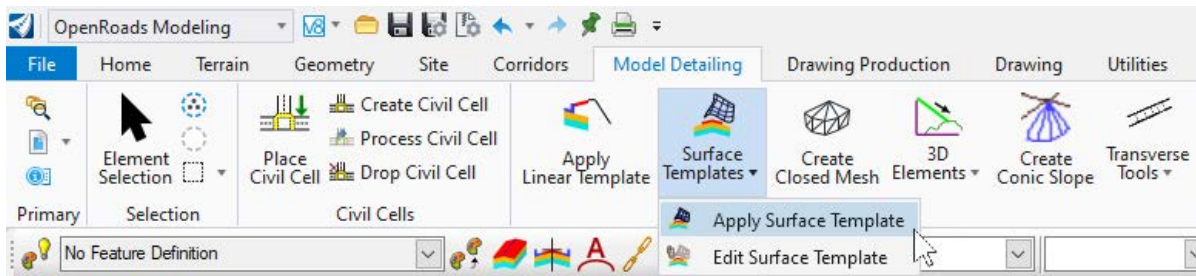

3. Following the *cursor prompt Locate a Terrain Model*, choose the **US98_ExPavt** and confirm the selection. Verify the surface template has been applied by hovering over the terrain and viewing the description.

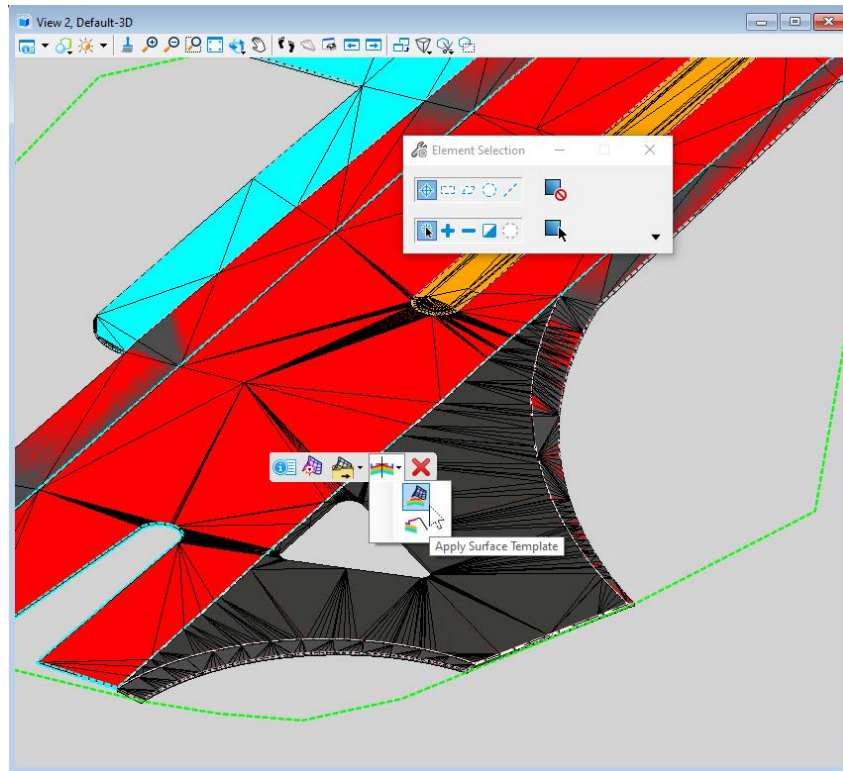

4. Repeat steps **2-3** for each terrain selecting the appropriate *Surface Template* for each feature. The menu option for applying surface templates is also available when selecting individual terrains.

Exercise 2.8 Edit Existing Feature Depth

The surface templates that have been applied are set with a default depth. In many cases, these depths may be acceptable. If not, the value will need to be changed manually.

1. Key **F2** to open both the *Default* & *Default-3D* views.
2. Make the *Default-3D* view **Active**.
3. Hover over the **US98_ExpAvt** terrain and choose the third menu option **Edit An Applied Surface Template**

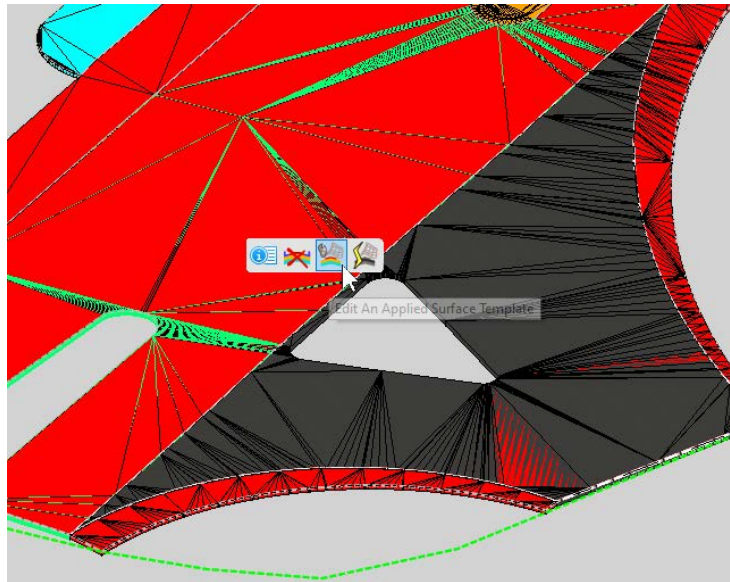

4. The *Editing Roadway Designer Template Drop* dialog launches with the active template displayed.

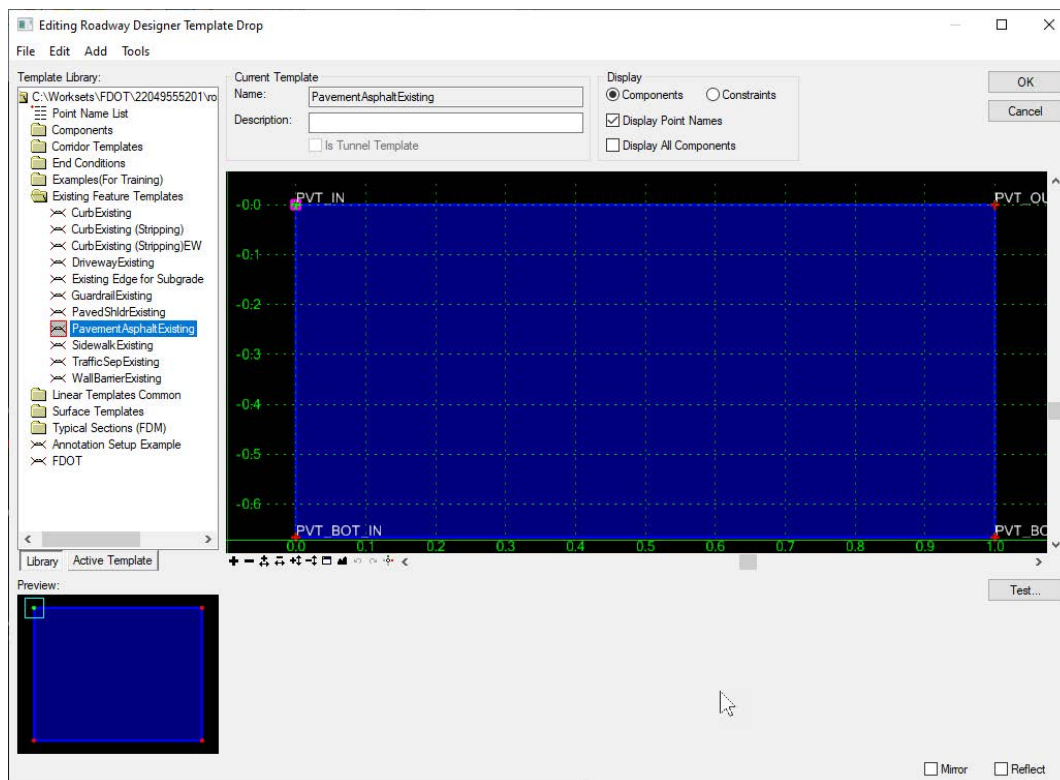

5. Select the **Active Template** tab in the bottom left corner of the dialog and navigate to the **EOP_PvtThick** item within the *Parametric Constraints* folder. Right click the item select **Edit...** to edit the default parametric value.

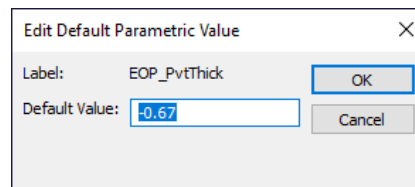
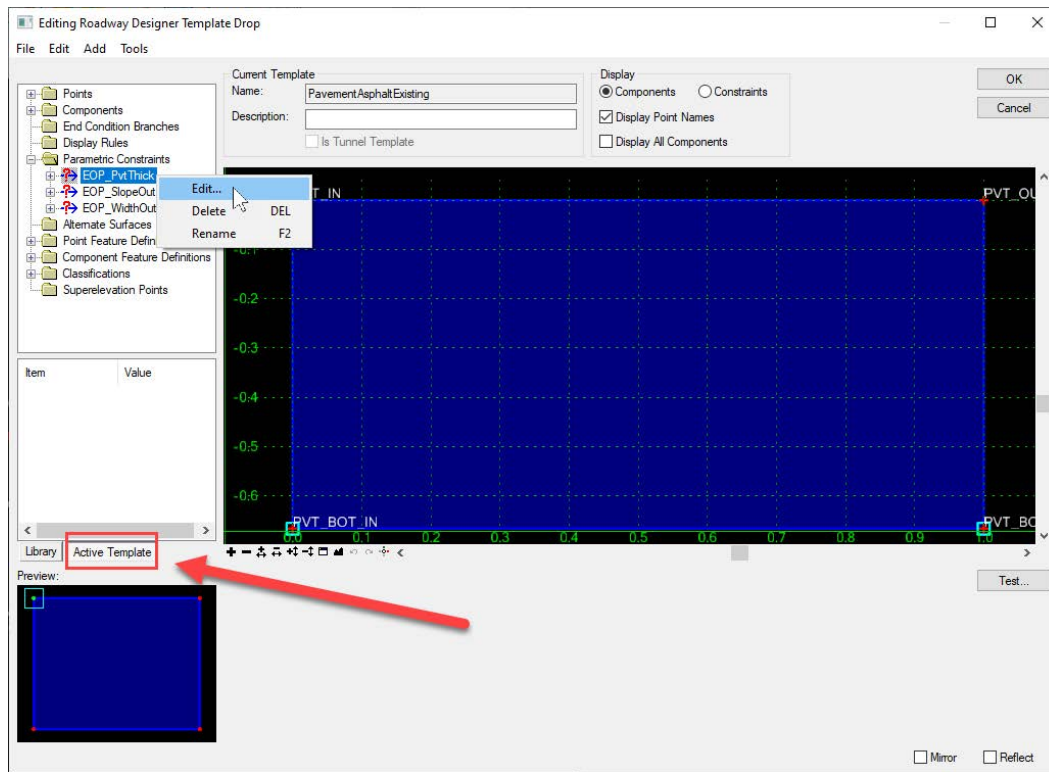

NOTE Alternatively, the surface template parametric values can be edited in Explorer from *OpenRoads Model>Terrain Models*.

Exercise 2.9 Add Curbs to the Existing Features

In this exercise, existing curbs will be developed. In order to use the civil tools to create the existing curbs, MicroStation elements will need to be changed to civil features. Linear templates will be applied to the featured elements to generate the depth needed for curbs.

1. Key **Ctrl+F1** to return to the *Default* view.
2. In the *Level Display*, turn off all levels except **CGBack_ep** & **PavtAsphalt_ep** and use the right click menu to turn **Off** the display of the **Default-3D** reference.

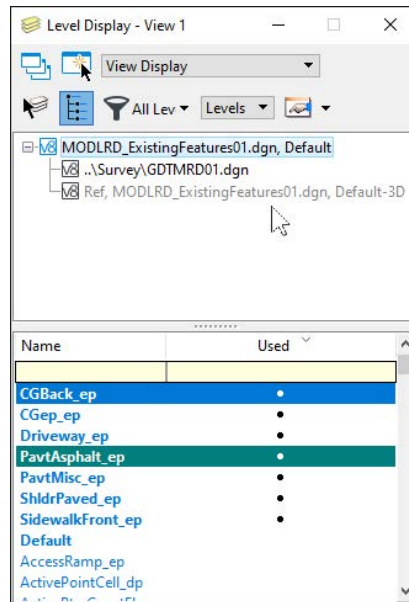

3. Use the **Element Selection** tool to create a *Selection Set* of the **CGBack_ep** elements.

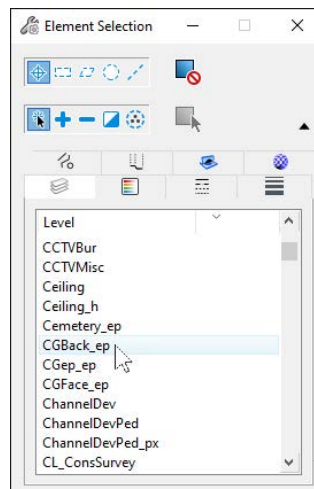

- On the *Geometry* tab of the ribbon, select **Set Feature Definition** under the *Standards* drop-down in the *General Tools* group. Change the *Feature Type* to **Linear** and set the *Feature Definition* to **Curb Back Existing** under the **Existing Features > Curb** folder. Follow the *cursor prompts* to apply the feature definition to the curb elements.

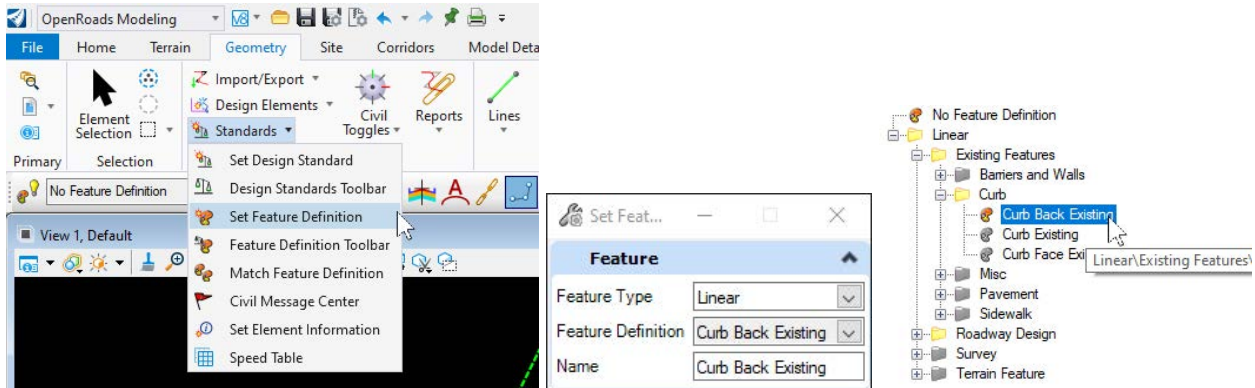

- Repeat steps 3-4 with the **PavtAsphalt_ep** elements, choosing a linear feature definition of **Pavement Asphalt Existing**.
- Use the **Open Profile Model** tool on one of the **CGBack_ep** elements, choose view 3 and data point to view the *Profile*. Choose the second option in the menu, **Set As Active Profile**.

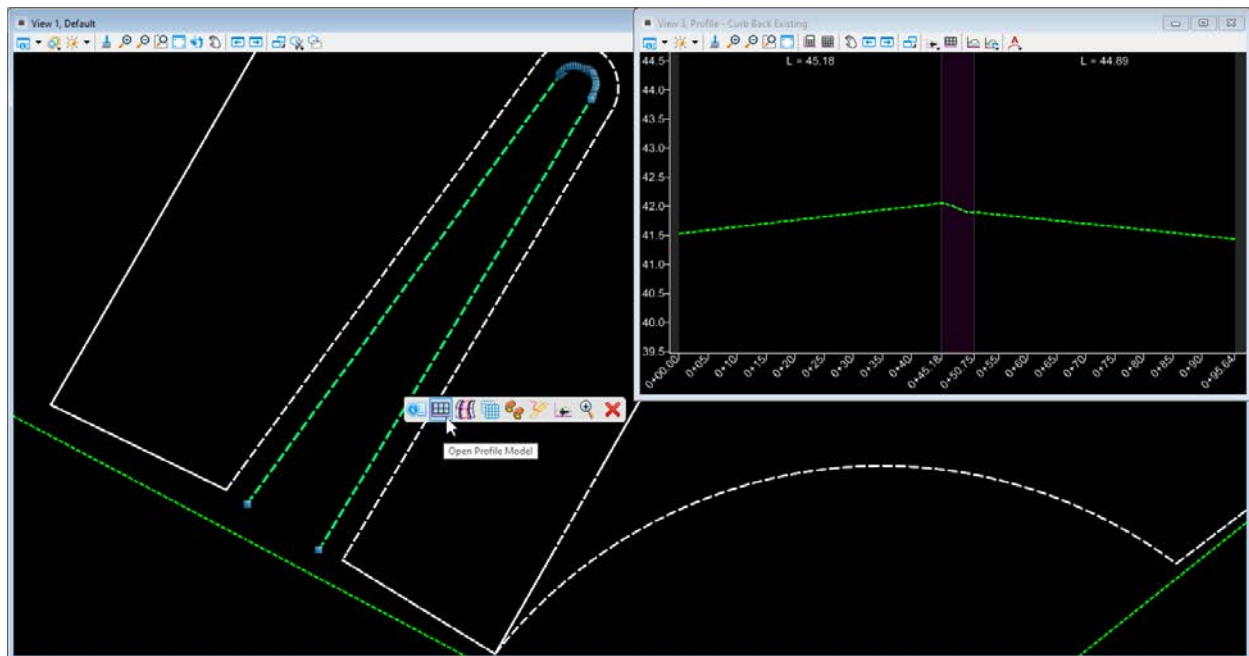

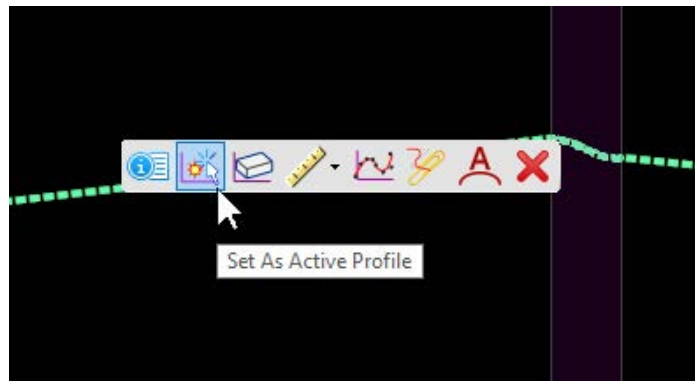

- On the *Model Detailing* tab of the ribbon, select the **Apply Linear Template** tool located in the *3D Tools* group. Choose the **CBack_ep** element from the previous step. Follow the *cursor prompts* and select the template **CurbExisting (Stripping)** under the *Existing Feature Templates* folder of the template library. Match the settings in the dialog below, and make sure the *Reflect Option* is sweeping the shape *towards* the edge of pavement. Accept all options to begin building the existing curb. Press **F2** to view the curb inside the 3D model.

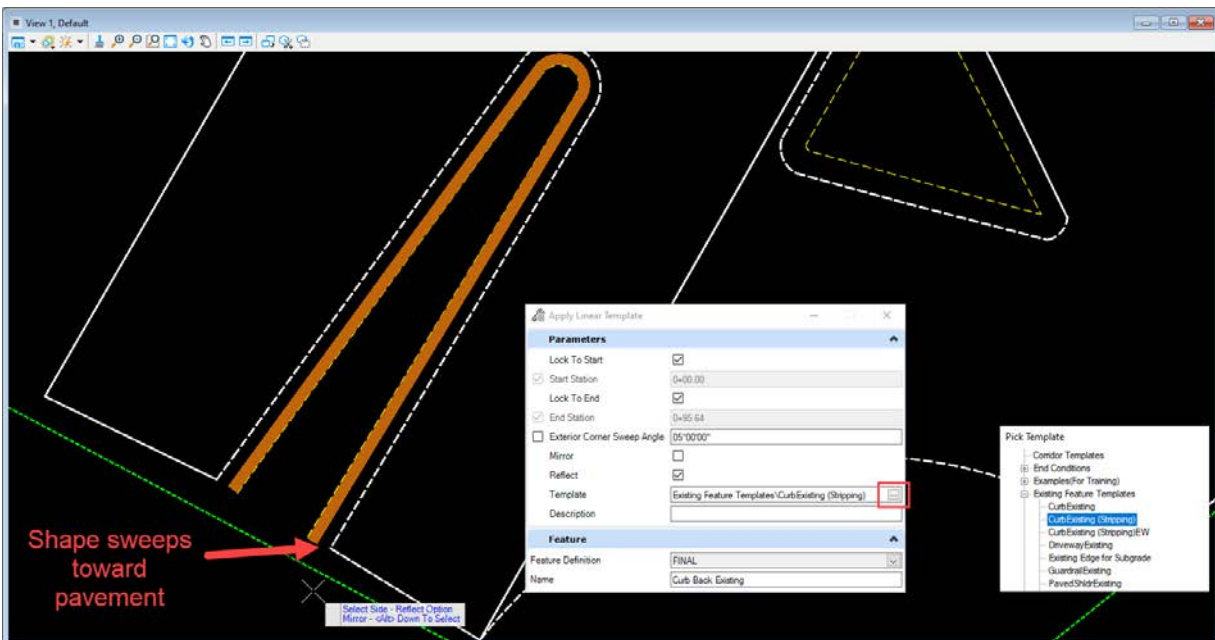
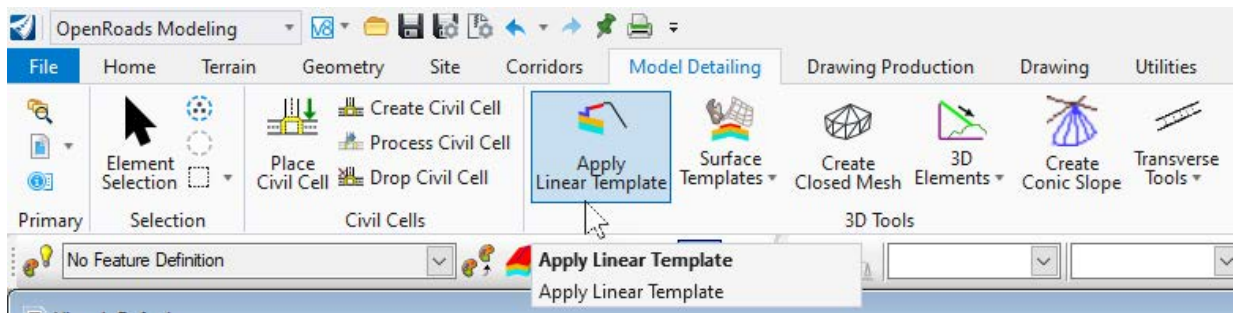

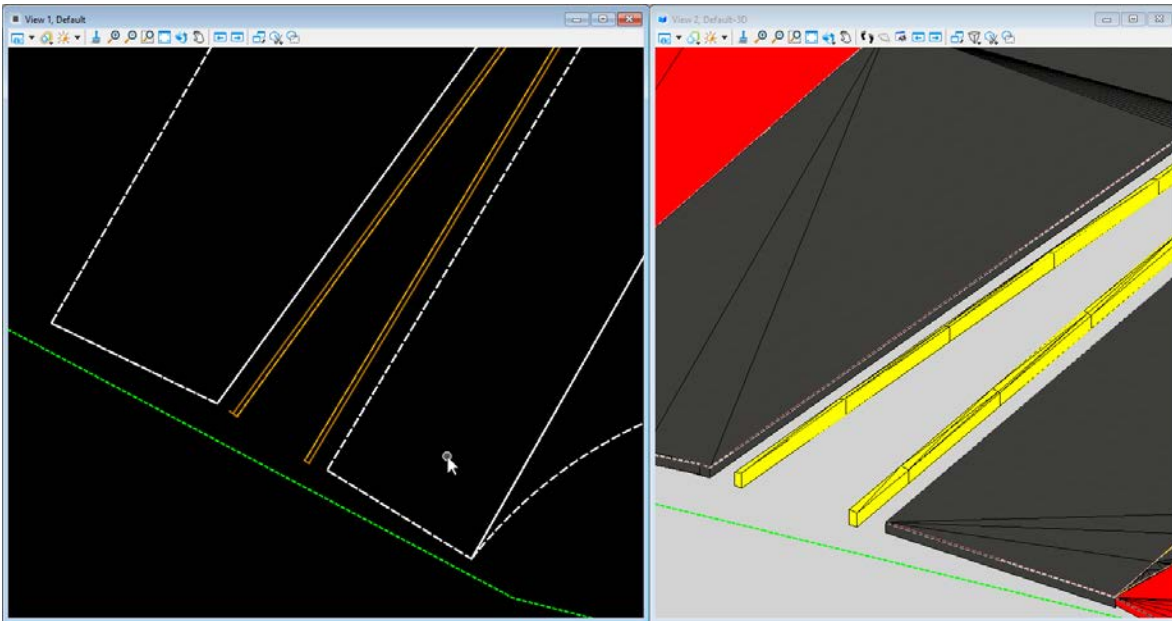

8. Locate the *Corridor handles* of the linear template and select **Add Corridor Reference** from the third menu option *Corridor References*. Follow the *cursor prompts* to select the adjacent **Pavement Asphalt Existing** element, then reset to complete. The curb should stretch to the edge of pavement.

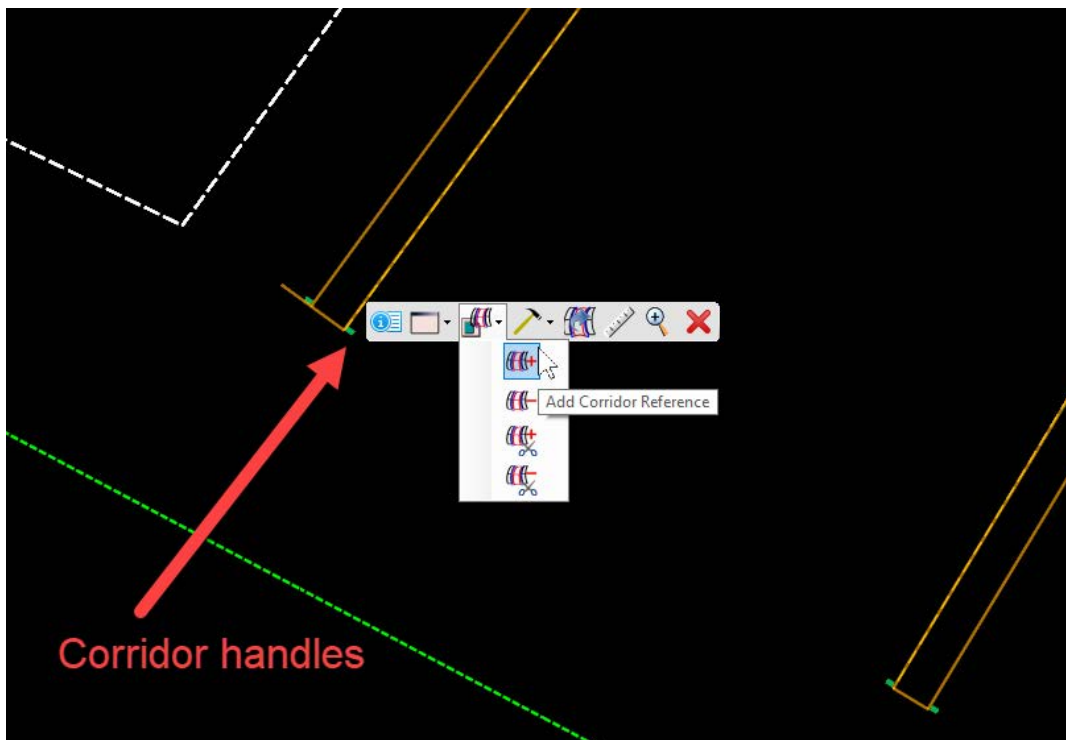

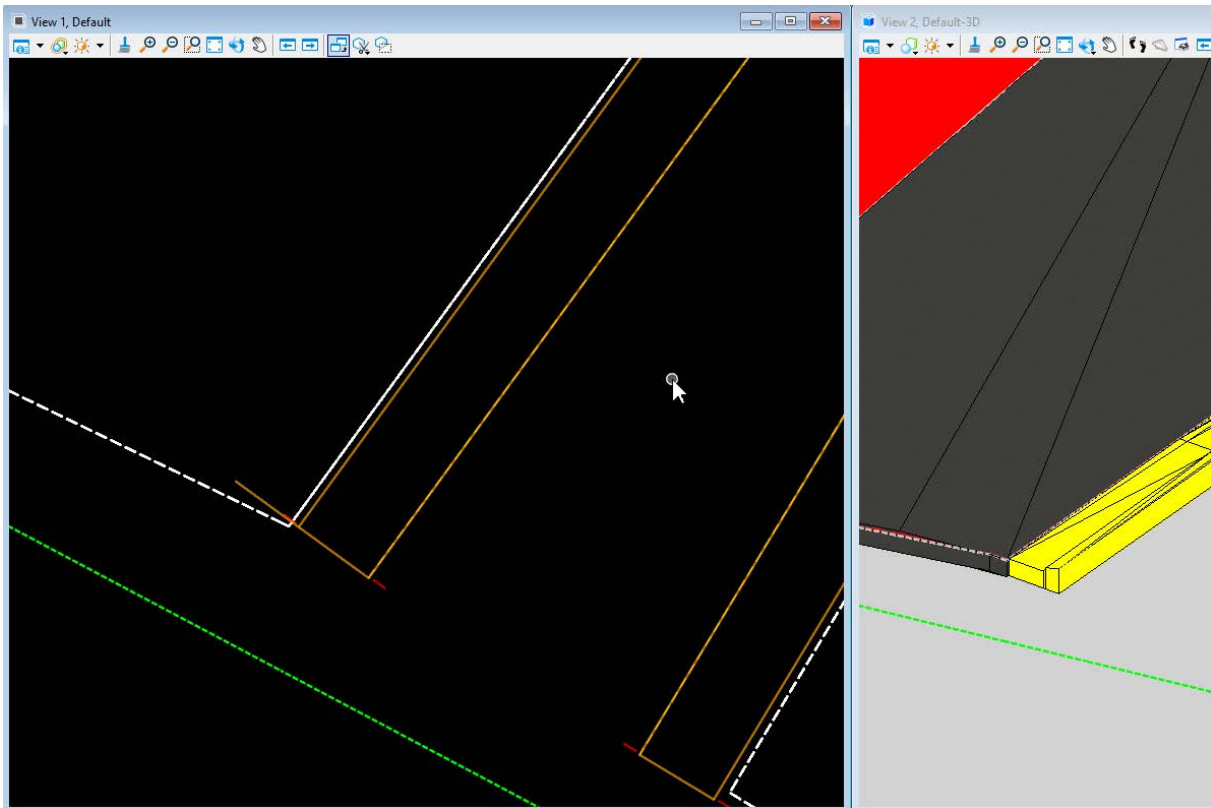

- Repeat steps **6-8** to model the remaining existing curbs. Some fine tuning on the curb linework may be required such as creating complex elements, also stopping the template just short of the end of the line sometimes helps.

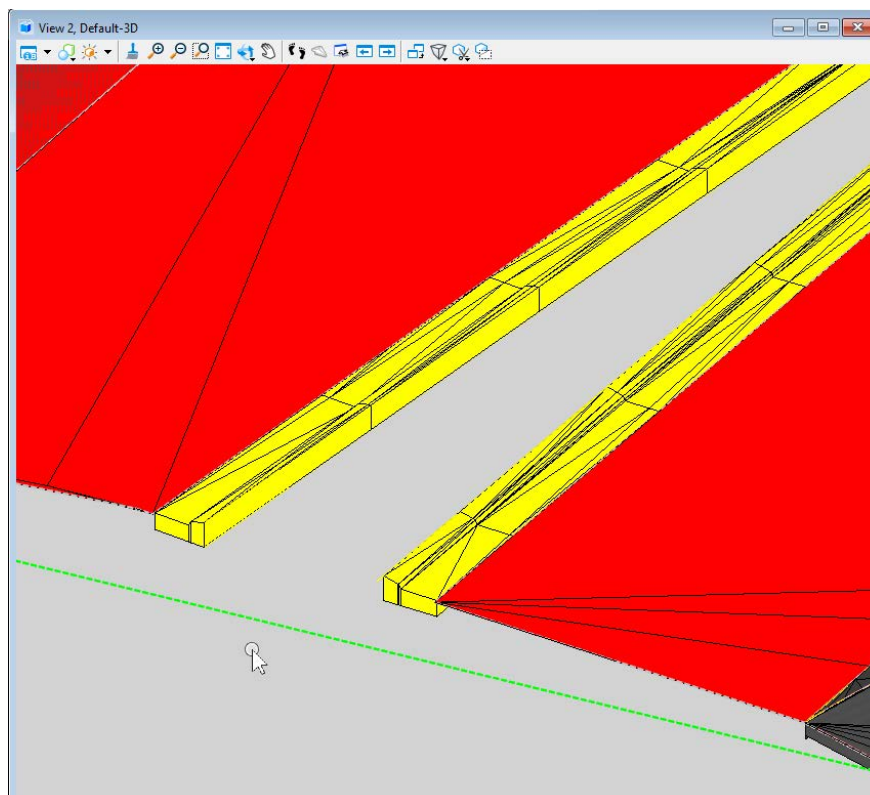
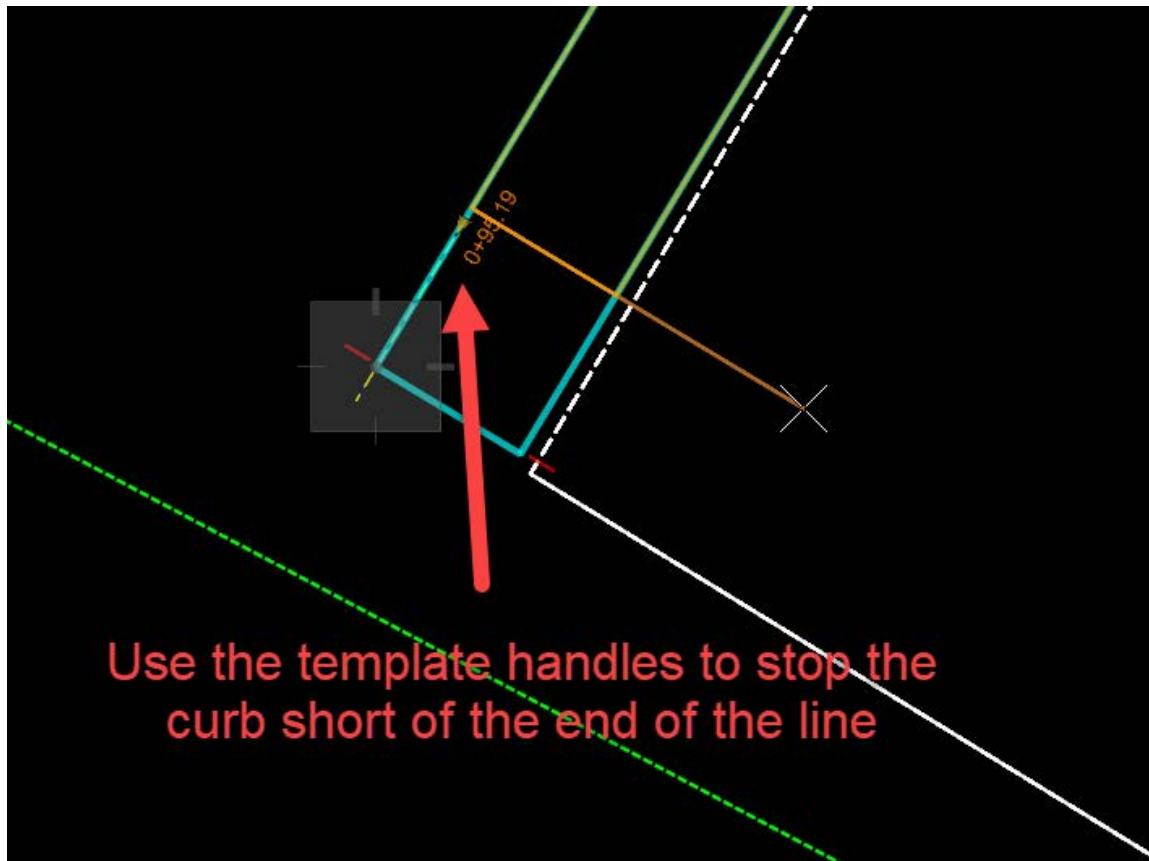

Exercise 2.10 View Existing Cross Sections

Once the *Existing Feature Terrains & Curbs* have been created, a dynamic cross section view can be used to verify the model data. In this exercise, a baseline in the *ALGNRD* reference file will be used to create a dynamic cross section view.

1. Key **Ctrl+F1** to return to the *Default* view, turn on all levels. In the *References* dialog, turn **ON** the display of the *MODLRD_ExistingFeatures01.dgn* reference. **Attach** the file *ALGNRD01.dgn* from the project *Roadway* folder.

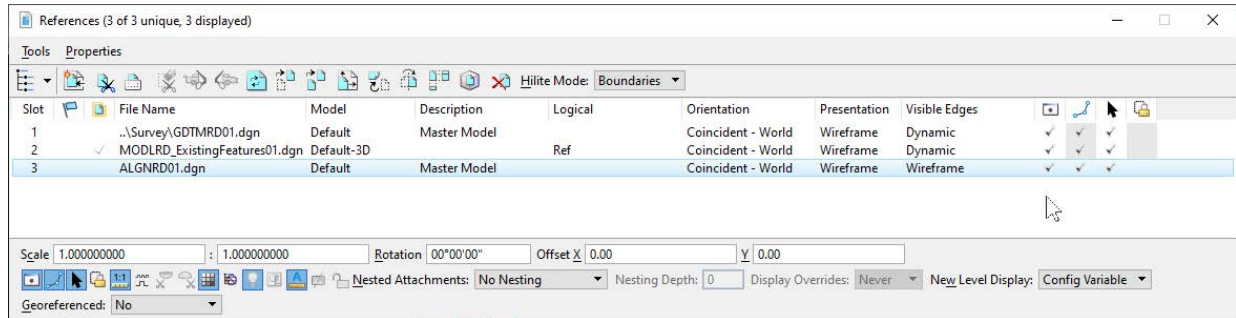

2. On the *Corridors* tab, select **Open Cross Section View** under the *Dynamic Sections* drop-down in the *Review* group.

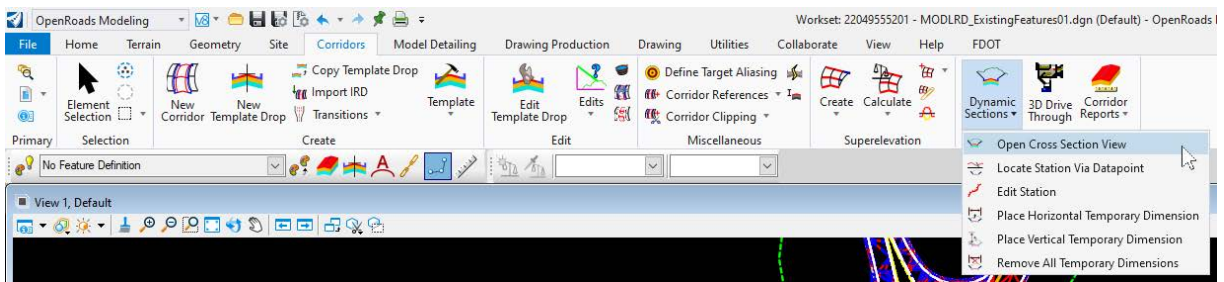

3. Follow the *cursor prompt* and select the **US98 Baseline**. Choose the **Left & Right Offset, Station, and Interval** values. **Open View 4** and click inside to display the *Cross Section* view.

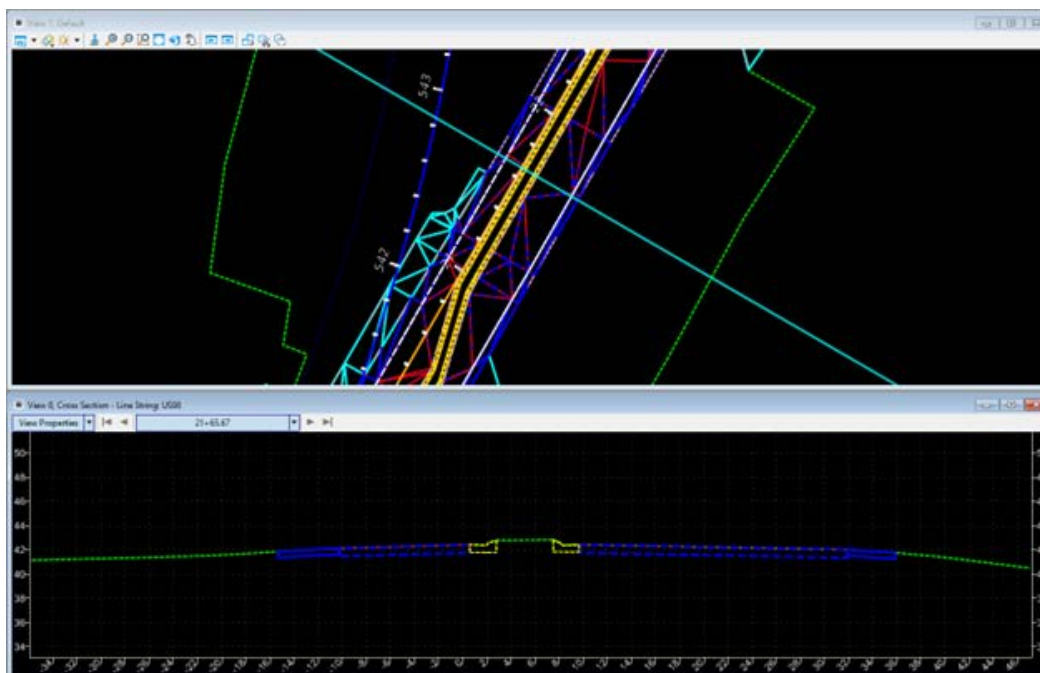

3 EXISTING ROW LINES

INTRODUCTION

These exercises will introduce the process of bringing in the existing ROW lines into the MODLRD file.

OBJECTIVE

In this chapter, a RWDTRD file will be created and set up using existing and proposed linework. The file will be referenced to the existing features model to view the ROW lines within the model.

EXERCISE OVERVIEW

Exercise 3.1	Create and set up a RWDTRD file.....	44
Exercise 3.2	View ROW lines in a cross section view.....	48

Exercise 3.1 Create and set up a RWDTRD file

1. Open the *BlankFile.dgn* in order to access the FDOT tab to create a new file in the next step.
2. Launch the **Create File** tool from the *FDOT* tab of the ribbon in the *Actions* group. Switch the *Discipline* to **Roadway** and the *File Group* to **Roadway Design Files**. Select the *Base Filename* **RWDTRD** from the list. Select a **Coordinate System** for the file or select a **County** which automatically populates the coordinate system dropdown. Make sure all settings match the dialog below, and then click **Create Open File**. Close the **Create File** tool.

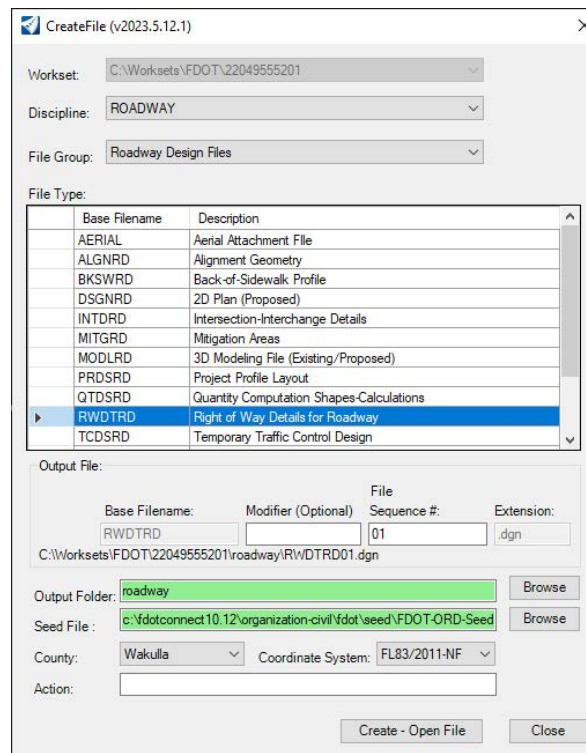

- Key **F9** to open the *References* dialog. **Attach** the file *RW22049555201.dgn* from the project *ROWMap* folder. Give this reference a *Logical Name* of **ROW**.

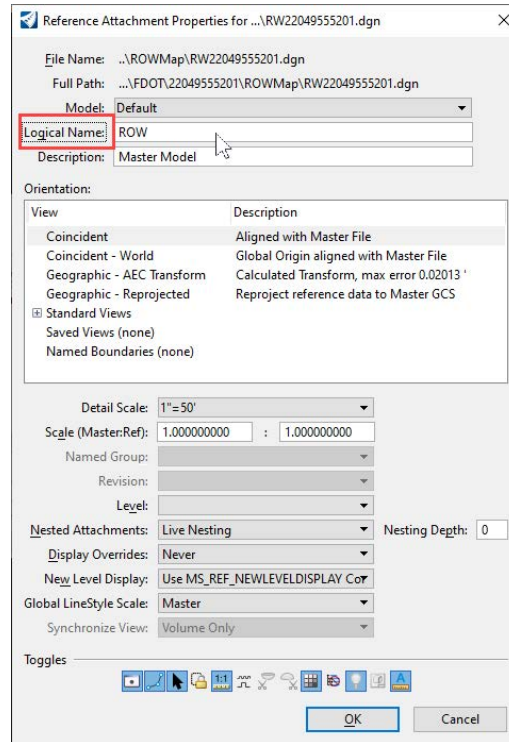

- On the *FDOT* tab of the ribbon, select **Copy Reference Levels** under the *Misc. Tools* drop-down in the *Actions* group. In the *Available Levels* list, select **RWLine & RWLine_ep** and click the *arrow* button to add them to the list of levels to process. Click **Copy** and then **Yes** to confirm the operation. **Close** the tool and **Detach** the reference file *RW22049555201.dgn*.

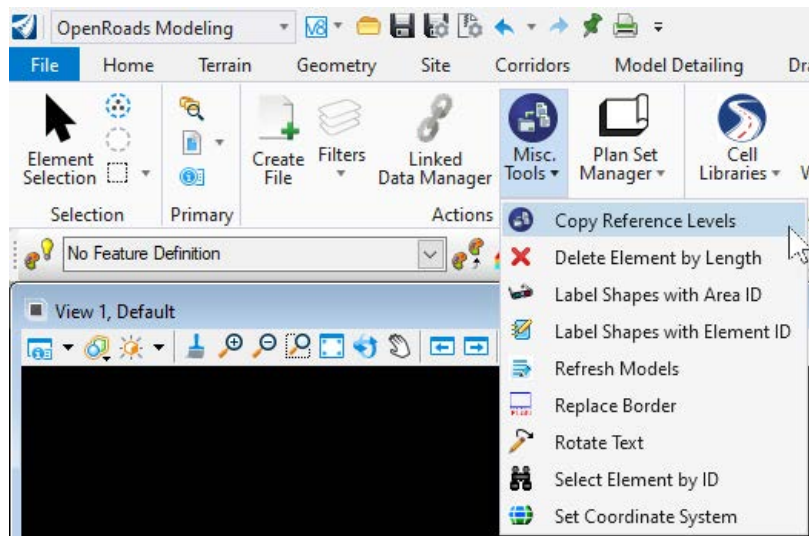

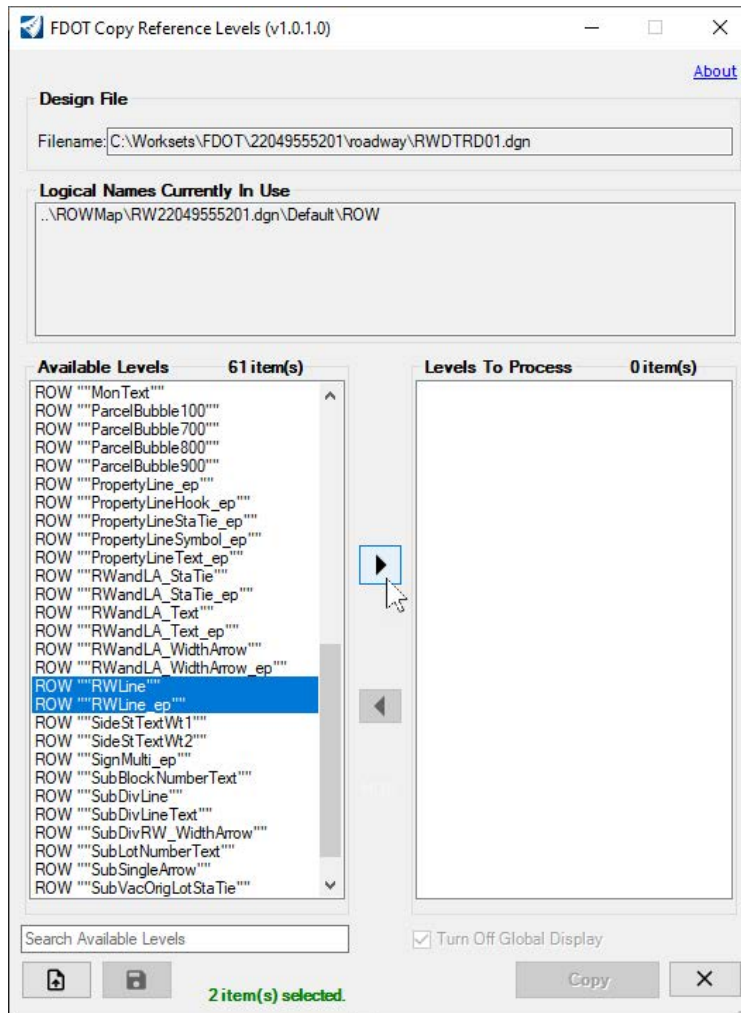

5. Attach the reference file, reference in the *GDTMRD01.dgn* file from the project *Survey* folder and set the terrain active.
6. Create a *Selection Set* of the **RWLine_ep** elements.
7. Use the **Set Feature Definition** tool under the *Standards* drop-down in the *General Tools* group to set a *Linear Feature* of **Right of Way Line Existing**.
8. Select all elements on the level **RWLine_ep**. On the *Geometry* tab, click **Profile From Surface** under the *Profile Creation* drop-down in the *Vertical* group. Choose **Right of Way Line Existing** as the *Feature Definition* and leave all other values as defaults. Accept all *cursor prompts* to profile the existing ROW lines.

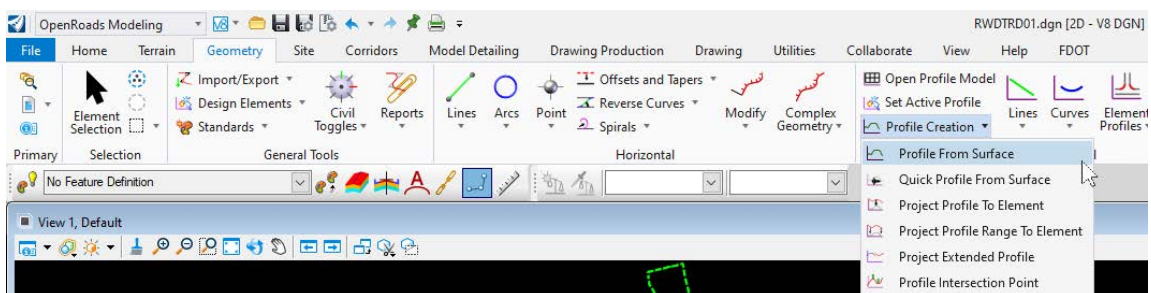

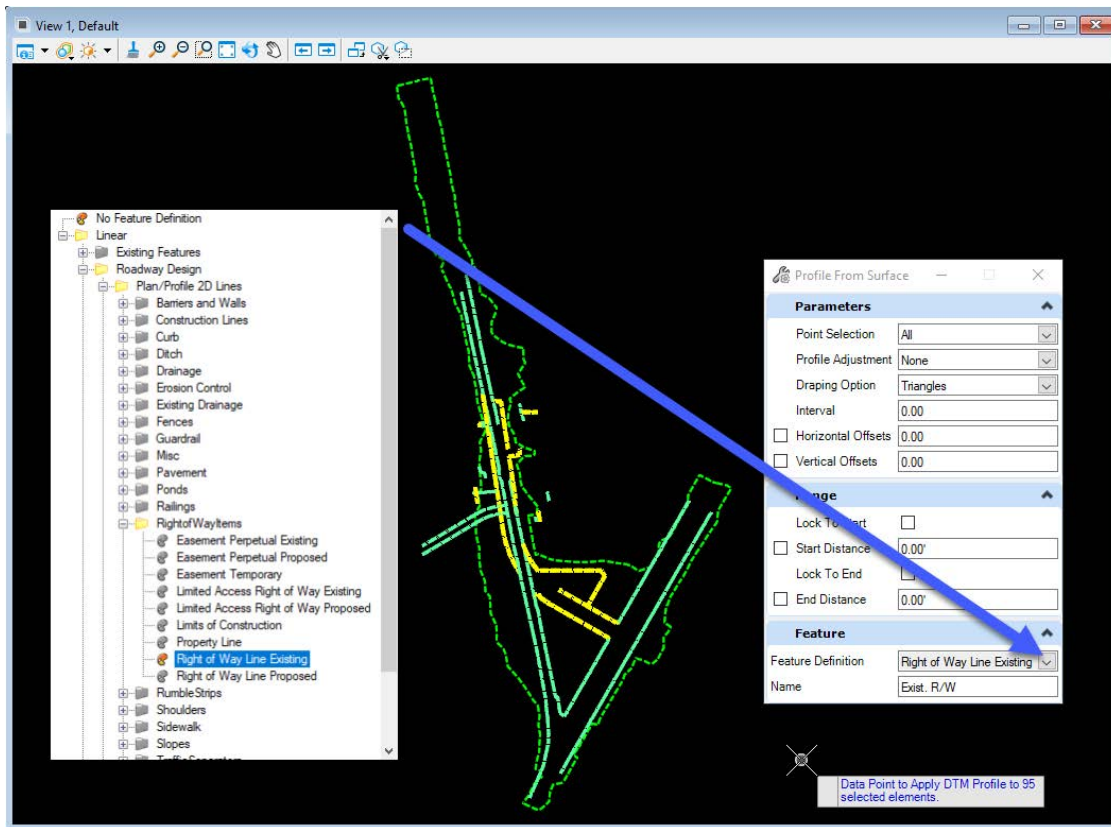

- Repeat steps 5-7 for the proposed ROW lines, choosing **Right of Way Line Proposed** as the *Feature Definition*. Key **F2** to view the results in the 3D view.

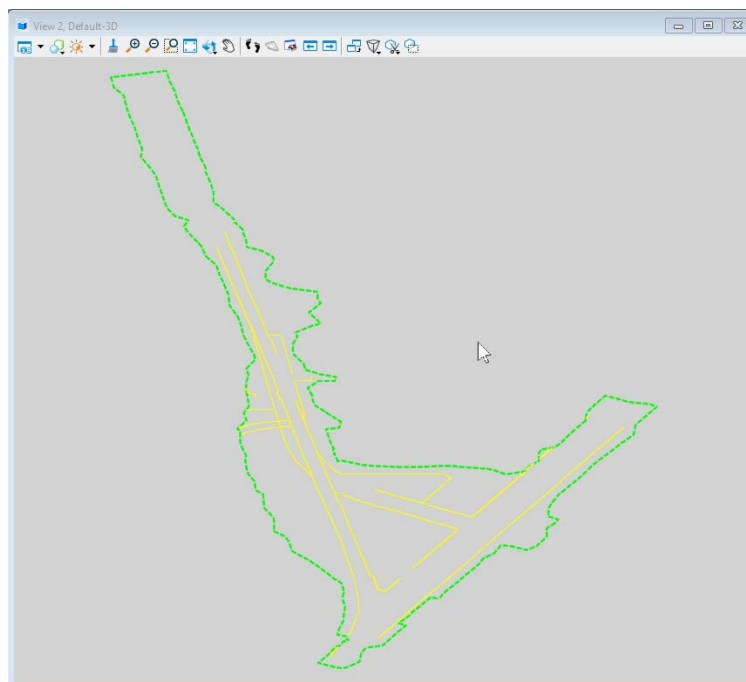

Exercise 3.2 View ROW lines in a cross section view

1. Open the file *MODLRD_ExistingFeatures01.dgn* in the project *Roadway* folder. Key **F9** to open the *References* dialog. **Attach** the file *RWDTRD01.dgn* from the project *Roadway* folder. Open *View 4, Cross Section*.
2. On the *Corridors* tab, select **Open Cross Section View** under the *Dynamic Sections* drop-down in the *Review* group.
3. Follow the *cursor prompt* and select the **US98 Baseline**. Choose the **Left & Right Offset, Station, and Interval** values. **Data Point** inside *View 4* to display the *Dynamic Cross Section* view.

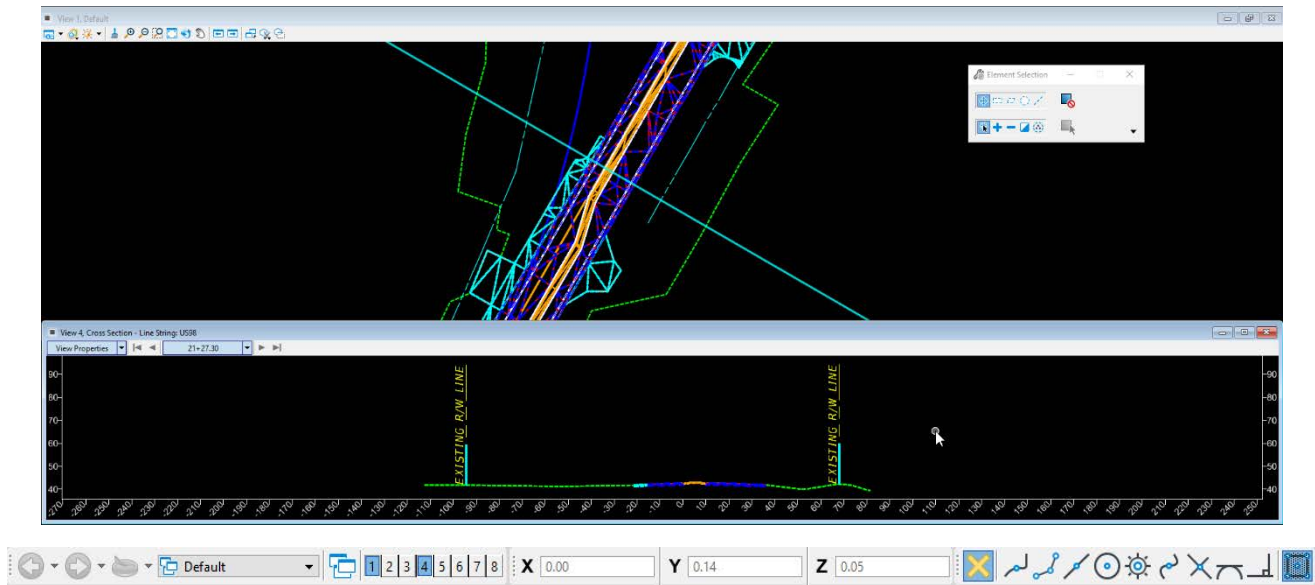

NOTE When using the *Dynamic Sections Review* tools, the *Right of Way* lines displayed may disappear if stepping through stations. This is a known bug that only affects the *dynamic view* and will not affect *cut cross sections*.

4 EXISTING UTILITIES MODELING

INTRODUCTION

These exercises will introduce the workflow used to layout existing Utilities lines. The Drainage and Utilities workflow will be used, and a SUDA & SUE database will be embedded into the file.

OBJECTIVE

A new MODLRD file will be created, and elements will be extracted from 2D and given features for 3D. This will allow the Existing Utilities to be viewed inside of the 3D model.

EXERCISE OVERVIEW

Exercise 4.1	Create and set up a MODLRD_ExistingUtilities file.....	50
Exercise 4.2	Use the Extract From Graphic tool.....	52
Exercise 4.3	Show Existing Utilities in a Dynamic Cross Section.....	53
Exercise 4.4	Creating a Profile From Vvh Data.....	54

Exercise 4.1 Create and set up a MODLRD_ExistingUtilities file

1. Launch the **Create File** tool from the *FDOT* tab of the ribbon in the *Actions* group. Switch the *Discipline* to **Roadway** and the *File Group* to **Roadway Design Files**. Select the *Base Filename* **MODLRD** from the list. In the *Modifier (Optional)* field, type **_ExistingUtilities**. Select a **Coordinate System** for the file or select a **County** which automatically populates the coordinate system dropdown. Make sure all settings match the dialog below, and then click **Create - Open File**. Close the **Create File** tool.

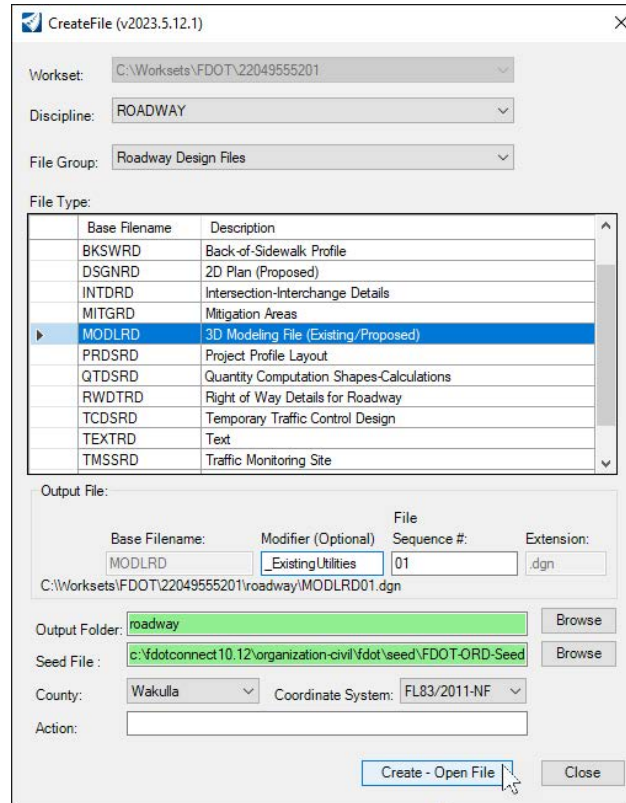

2. Navigate to the *Drainage and Utilities* workflow. On the *Layout* tab of the ribbon, select **Place Node** in the *Layout* group. A message will appear prompting to embed files for a Drainage and Utilities project. Click **Yes** and the file will process.

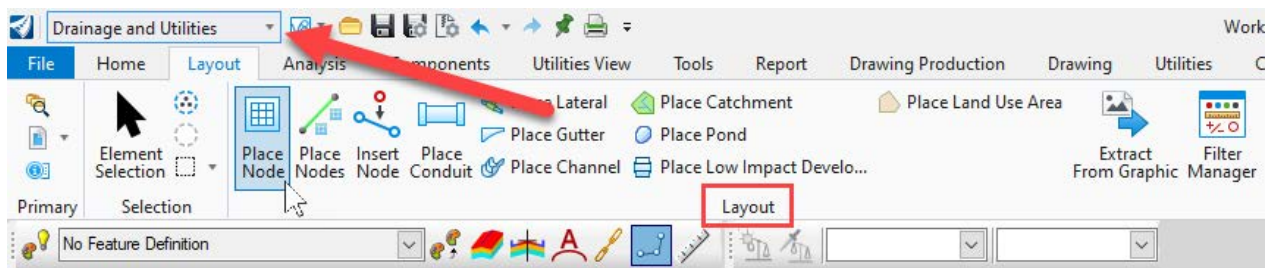

NOTE This action cannot be undone. The files become permanently embedded into the dgn.

3. Key **F9** to open the *References* dialog. **Attach** the file *GDTMRD01.dgn* from the project *Survey* folder. Set the *Existing Ground* as **Active**.

4. Select the Terrain and chose **Set Active Terrain** from the context menu.
5. Key **F2** to open both the *Default* and *Default-3D* views and repeat step 4 in the 3D view to filter the level display of the 3D survey reference.
6. Key **F10** to open the *Level Display*. Select the *SURVRD01.dgn* reference and choose **Filters** from the drop down. In the *Name* list, click on **STANDARDS.UTEXRD** to filter the level display of the 2D survey reference.
7. Key **F2** to open both the *Default* and *Default-3D* views and repeat step 6 in the 3D view to filter the level display of the 3D survey reference. Use the Save Settings

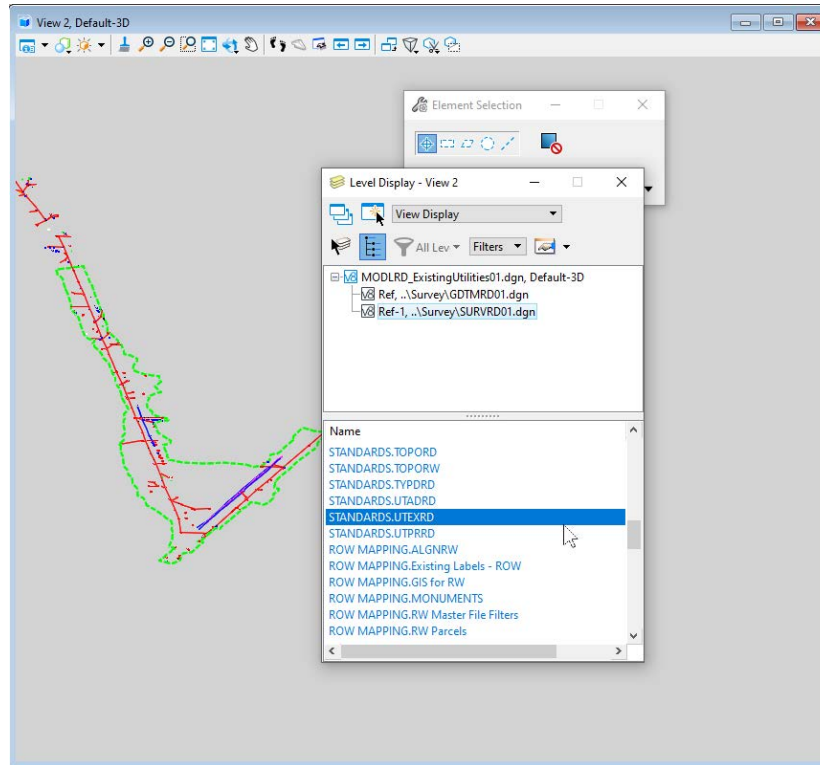

Exercise 4.2 Use the Extract From Graphic tool

1. On the *Layout* tab of the ribbon, select **Extract From Graphic** in the *Layout* group.

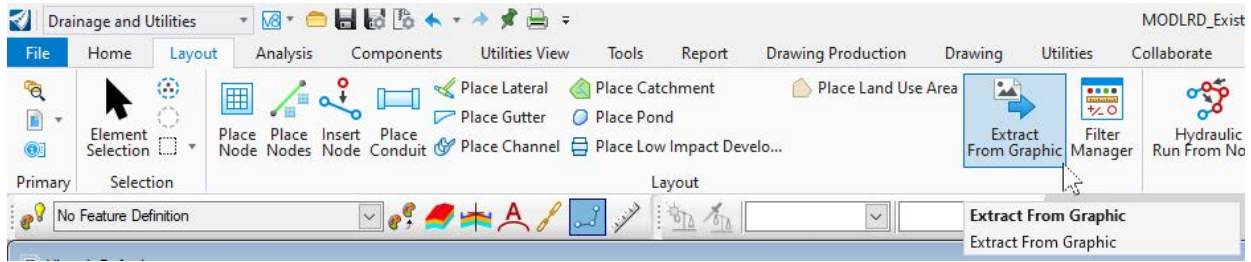

2. In the *Extract Utilities From Graphics* dialog, choose **Selection** for the *Method*, leave *Use 3D Element Elevations?* unchecked, use **-3.00** for the *Vertical Offset*, leave *Search Radius* at **0.00**, select **Existing Water Main (Quality Level B)** for the *Feature Definition*, choose **6"** for the *Description*, select **Water Manhole** for the *Node Feature* (this is initially greyed out but becomes active after choosing a feature definition). Select the NPW(B) element along US98 in the Default view. Accept the cursor prompts to create the utility lines.

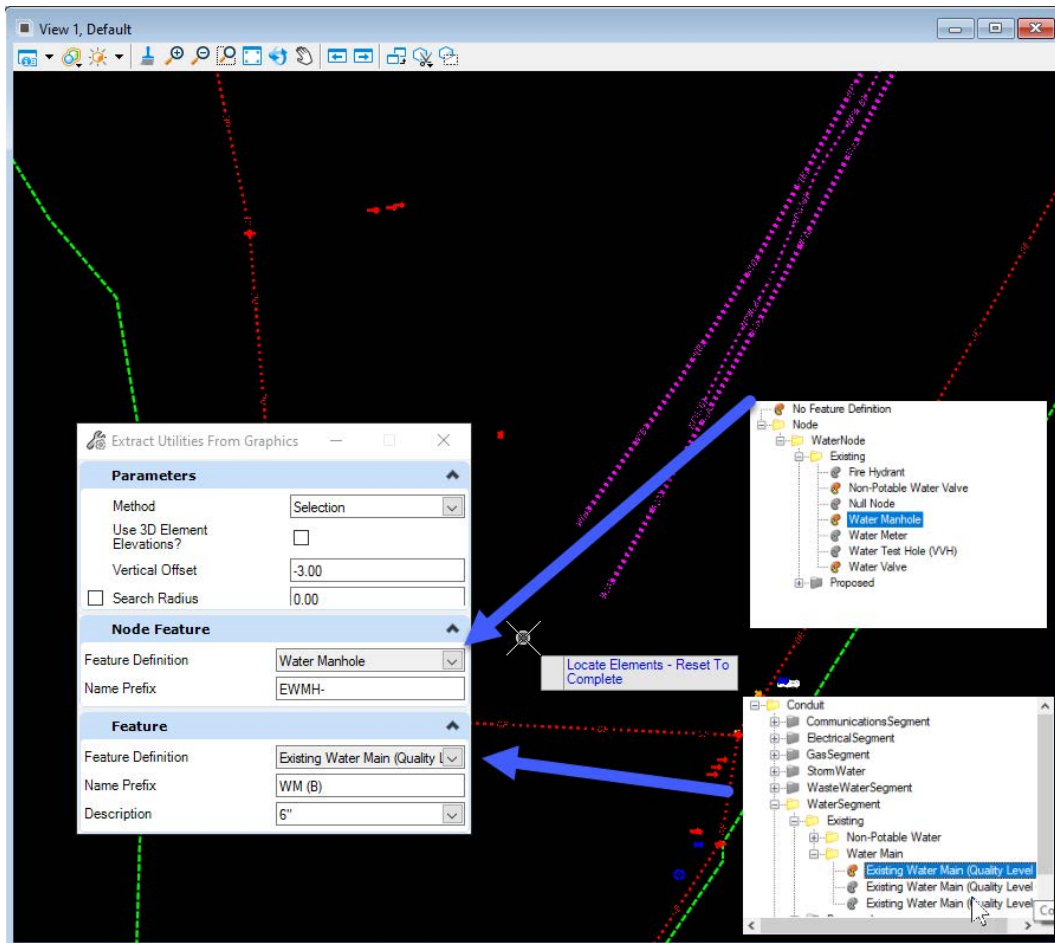

3. Repeat step 2 for each existing utility line selecting the appropriate *Feature Definition* and *Node Feature*. Key **F2** to see the results in the 3D model. If the size of the utility is incorrect, it can be updated in Link's properties *Description* field under **Feature**.

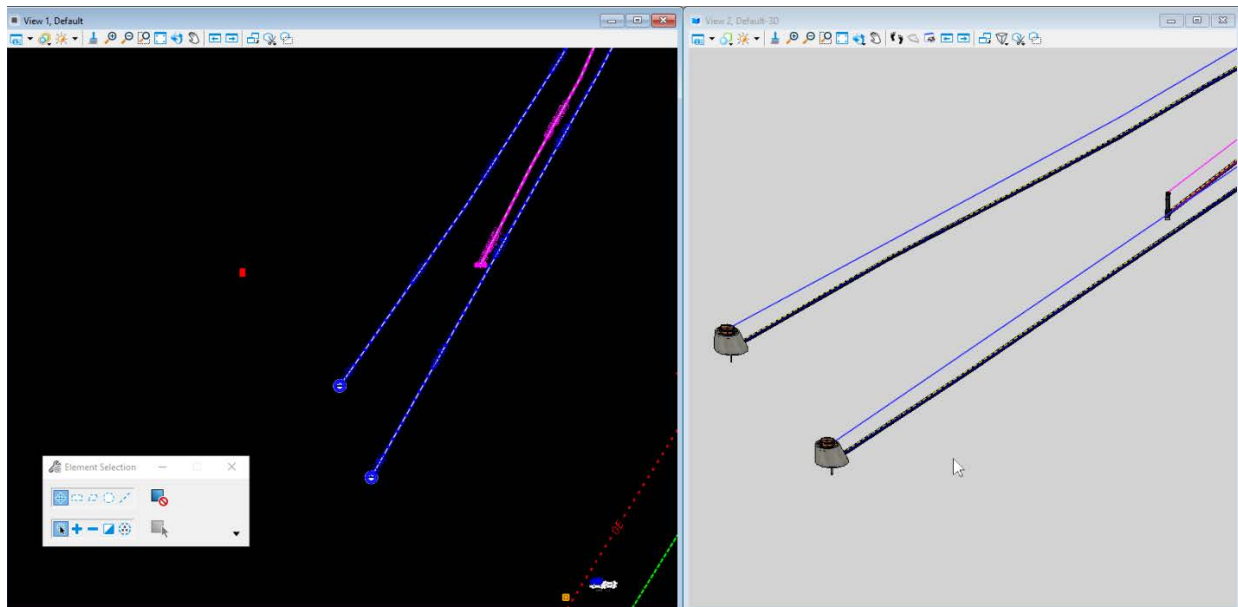

NOTE OE features do not need to be modeled.
 Optional: Turn off SURVRD in both the default and default-3D models

Exercise 4.3 Show Existing Utilities in a Dynamic Cross Section

1. Open the file *MODLRD_ExistingFeatures01.dgn* from the project *Roadway* folder.
2. Use the *References* dialog and **Attach** the file *MODLRD_ExistingUtilities01.dgn* to the *Default* view.
3. Switch to the *OpenRoads Modeling* workflow. On the *Corridors* tab, select **Open Cross Section View** under the *Dynamic Sections* drop-down in the *Review* group.
4. Follow the *cursor prompt* and select the **US98 Baseline**. Choose the **Left & Right Offset, Station,** and **Interval** values. **Open View 4** and click inside to display the *Dynamic Cross Section* view.

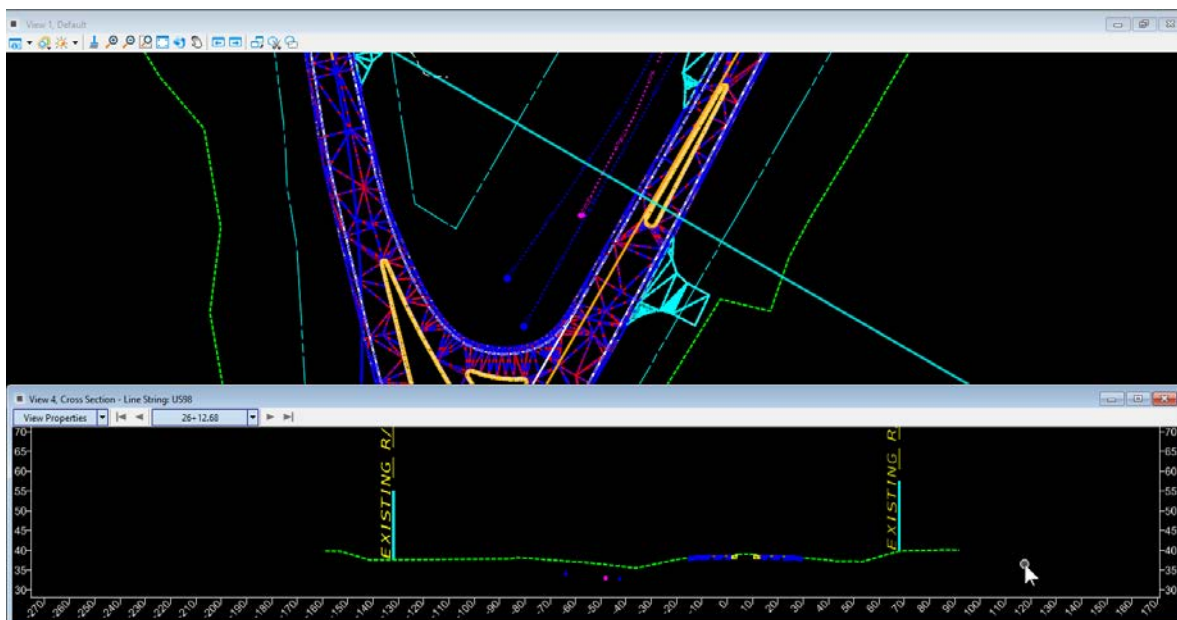

Exercise 4.4 Creating a Profile From Vvh Data

Once the existing utilities have been created, Vvh data can be plotted into the model. This exercise demonstrates the use of OpenRoads tools to incorporate utility locates.

Vvh information can be provided in different formats. The most common formats are PDF documents and Excel spreadsheets as well as .dgn files. Whatever the format is, the goal of this exercise is to import that information in a useable manner.

The example file included will be a PDF document that needs data extracted from it.

1. Open the delivered verified utilities PDF **22049555201_VERIFIEDUTILITIES** in the project *Survey>eng_data* folder and examine the Vvh information.

SUMMARY OF VERIFIED UTILITIES									
Vvh #	UTILITY DESCRIPTION (Owner, Type)	SIZE	MATERIALS	# US98			EXISTING GROUND ELEVATION	TOP ELEVATION	COMMENTS
				STATION	OFFSET	LT/RT			
UT01	10" 11.5" 11.5" WATER MAIN	11"	200	21220.13	47.14	L	36.73	36.88	
UT02	10" 11.5" 11.5" WATER MAIN	11"	200	21220.39	47.14	L	36.73	36.88	
UT03	10" 11.5" 11.5" WATER MAIN	11"	200	21220.65	47.14	L	36.73	36.88	
UT04	10" 11.5" 11.5" WATER MAIN	11"	200	21220.91	47.14	L	36.73	36.88	
UT05	10" 11.5" 11.5" WATER MAIN	11"	200	21221.17	47.14	L	36.73	36.88	
UT06	10" 11.5" 11.5" WATER MAIN	11"	200	21221.43	47.14	L	36.73	36.88	
UT07	10" 11.5" 11.5" WATER MAIN	11"	200	21221.69	47.14	L	36.73	36.88	
UT08	10" 11.5" 11.5" WATER MAIN	11"	200	21221.95	47.14	L	36.73	36.88	
UT09	10" 11.5" 11.5" WATER MAIN	11"	200	21222.21	47.14	L	36.73	36.88	
UT10	10" 11.5" 11.5" WATER MAIN	11"	200	21222.47	47.14	L	36.73	36.88	
UT11	10" 11.5" 11.5" WATER MAIN	11"	200	21222.73	47.14	L	36.73	36.88	
UT12	10" 11.5" 11.5" WATER MAIN	11"	200	21222.99	47.14	L	36.73	36.88	
UT13	10" 11.5" 11.5" WATER MAIN	11"	200	21223.25	47.14	L	36.73	36.88	
UT14	10" 11.5" 11.5" WATER MAIN	11"	200	21223.51	47.14	L	36.73	36.88	
UT15	10" 11.5" 11.5" WATER MAIN	11"	200	21223.77	47.14	L	36.73	36.88	

NON-UTILITY ENGINEERING NOTES

1. THIS SHEET IS FOR INFORMATION PURPOSES ONLY ABOVE GROUND UTILITY FEATURES, AND NOT FOR CONSTRUCTION.
2. SURVEY WAS PERFORMED BY LINDA S. WALKER, P.E.
3. ELEVATION INFORMATION IS RELATIVE TO NORTH AMERICAN VERTICAL DATUM OF 1988 (NAVD 88).
4. STATION AND OFFSET DERIVED FROM BASELINE OF SURVEY OF US 98.
5. PROJECT STATE U.S. SURVEY FEET.
6. THE SPECIFIC PURPOSE OF SURVEY IS TO DETERMINE THE HORIZONTAL AND VERTICAL LOCATION OF UNDER TEST HOLES.

SURVEYOR'S CERTIFICATION

I HEREBY CERTIFY THAT EXAMPLE TEXT WAS MADE FOR THE PURPOSE OF SURVEYING, REPRESENTING, DESCRIBING AND MARKING THE VACUUM EXCAVATION TEST HOLES.

THIS PLAN HAS BEEN CAREFULLY
 REVIEWED AND I HEREBY
 CERTIFY THAT THE SAME IS
 TRUE AND CORRECT AS SHOWN
 ON THE DATE ADJACENT TO THE SEAL

LINDA S. WALKER, P.E. No. 12345
 SURVEY & MAPPING, INC.
 123 MAIN STREET
 TALLAHASSEE, FL 32301

PRINTED COPIES OF THIS DOCUMENT ARE
 NOT CONSIDERED VALID UNLESS
 AND THE SIGNATURE MUST BE VERIFIED
 ON ANY ELECTRONIC COPIES.

*NOTE: THIS SHEET IS PROVIDED AS AN EXAMPLE GRAPHIC AND IS ONLY USED FOR TRAINING PURPOSES.

DATE	DESCRIPTION	DATE	DESCRIPTION	PROFESSIONAL SURVEYOR AND MAPPER	STATE OF FLORIDA DEPARTMENT OF TRANSPORTATION	SHEET NO.
				LINDA S. WALKER LICENSE NUMBER: 12345 123 MAIN STREET TALLAHASSEE, FL 32301	PROJECT NO.: 22049555201 US 98 WALKULA 22049555201	17V-1

2. Launch **Microsoft Word** and open the PDF **22049555201_VerifiedUtilities.csv** Select **Convert All** to convert the document.

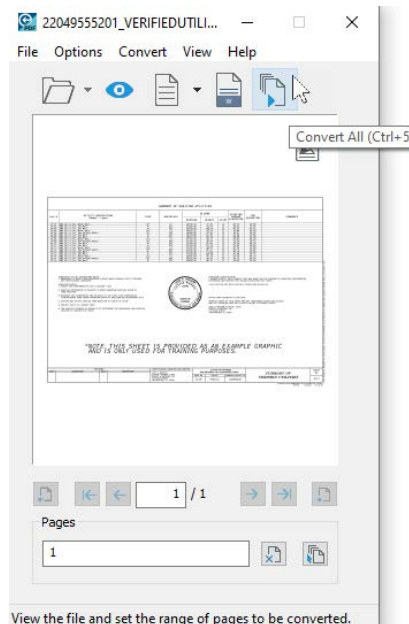

NOTE If you do not have software that can convert the PDF, manual copying and editing of the information may be required.

- When the document opens, highlight, and Copy the column information within the table.

SUMMARY OF VERIFIED UTILITIES									
Vvh # (Owner, type)	UTILITY DESCRIPTION (DPC)	SIZE	MATERIALS	@ US98			EXISTING GROUND ELEVATION	TOP ELEVATION	COMMENTS
				STATION	OFFSET	LT/RT			
TH-01	ABC Utilities, water, 8in	6"	PVC	25+20.33	41.54	LT	36.73	30.98	
TH-02	ABC Utilities, water, 8in	6"	PVC	25+20.50	70.7	LT	38.32	32.42	
TH-03	ABC Utilities, water, 8in	6"	PVC	26+70.37	43.23	LT	35.89	30.29	
TH-04	ABC Utilities, non-potable water, 8in	6"	PVC	26+69.98	49.49	LT	36.41	30.66	
TH-05	ABC Utilities, water, 8in	6"	PVC	26+70.66	61.2	LT	36.39	30.64	
TH-06	ABC Utilities, water, 8in	6"	PVC	31+20.50	49.11	LT	35.03	29.28	
TH-07	ABC Utilities, water, 10in	10"	CI	31+20.50	58.44	LT	35.1	29.15	
TH-08	ABC Utilities, water, 8in	6"	PVC	20.22	67.03	LT	35.36	29.39	
TH-09	ABC Utilities, water, 8in	6"	PVC	37+20.50	48.02	LT	30.74	24.99	
TH-10	ABC Utilities, water, 10in	10"	CI	37+20.50	60.11	LT	30.73	24.87	
TH-11	ABC Utilities, water, 8in	6"	PVC	37+20.50	71.02	LT	30.73	24.6	
TH-12	ABC Utilities, water, 8in	6"	PVC	39+97.64	47.19	LT	33.16	26.14	
TH-13	ABC Utilities, non-potable water, 10in	10"	CI	40+20.50	58.75	LT	33.13	25.59	

SUBSURFACE UTILITY ENGINEERING NOTES:
 1. OWNERSHIP IS BASED UPON OBSERVING VISIBLE ABOVE GROUND UTILITY FEATURES AND PROFESSIONAL JUDGEMENT.
 2. VERTICAL INFORMATION IS RELATIVE TO NORTH AMERICAN VERTICAL DATUM OF 1988 (NAVD 88).
 3. BEARINGS AND COORDINATES ARE RELATIVE TO THE STATE PLAIN COORDINATES FLORIDA NORTH ZONE, NORTH AMERICAN DATUM OF 1983 (NAD 83), ADJUSTMENT 2011.
 4. STATION AND OFFSET DERIVED FROM BASELINE OF SURVEY OF US 98.
 5. PROJECT LINES: US 98 SURVEY SET.
 6. THE SPECIFIC PURPOSE OF SURVEY IS TO DETERMINE THE HORIZONTAL AND VERTICAL LOCATION OF VACUUM TEST HOLES.

SURVEYOR'S NOTES:
 1. SURVEY WAS PERFORMED BY LUKE S. WALKER, P.S.M.
 2. THIS SHEET HAS NOT BEEN DIGITALLY SIGNED AND SEALED BY:

SURVEYOR'S CERTIFICATION:
 I HEREBY CERTIFY THIS EXAMPLE TEXT WAS MADE FOR THE PURPOSE OF SURVEYING, DESCRIBING AND MAPPING THE VACUUM EXCAVATION TEST HOLES.
 THIS ITEM HAS NOT BEEN DIGITALLY SIGNED AND SEALED BY:

STATE OF FLORIDA
 DEPARTMENT OF TRANSPORTATION
 ROAD NO. COUNTY FINANCIAL PROJECT
 US 98 WAKULLA 2204955201

LUKE S. WALKER, P.S.M. NO. 12345
 SURVEY & MAPPING, INC.
 123 MAIN STREET
 TALLAHASSEE, FL 32301

***NOTE: THIS SHEET IS PROVIDED AS AN EXAMPLE GRAPHIC AND IS ONLY USED FOR TRAINING PURPOSES.**

DATE	REVISIONS	PROFESSIONAL SURVEYOR AND IMPPER	STATE OF FLORIDA DEPARTMENT OF TRANSPORTATION	SHEET NO.
		LUKE S. WALKER LICENSE NUMBER: 12345 SURVEY & MAPPING, INC. 123 MAIN STREET TALLAHASSEE, FL 32301	ROAD NO. COUNTY FINANCIAL PROJECT US 98 WAKULLA 2204955201	SUMMARY OF VERIFIED UTILITIES UT-1

- Open Microsoft Excel and Create a new workbook. Right-click on the A1 cell and Paste the data using the option Match Destination Formatting (M).

Vvh #	UTILITY DESCRIPTION (Owner, type)	SIZE	MATERIALS	@ US98	EXISTING GROUND ELEVATION	TOP ELEVATION	COMMENTS
				STATION	OFFSET	LT/RT	
TH-01	ABC Utilities, water, 8in	6"	PVC	25+20.33	41.54	LT	36.73 30.98
TH-02	ABC Utilities, water, 8in	6"	PVC	25+20.50	70.7	LT	38.32 32.42
TH-03	ABC Utilities, water, 8in	6"	PVC	26+70.37	43.23	LT	35.89 30.29
TH-04	ABC Utilities, non-potable water, 8in	6"	PVC	26+69.98	49.49	LT	36.41 30.66
TH-05	ABC Utilities, water, 8in	6"	PVC	26+70.66	61.2	LT	36.39 30.64
TH-06	ABC Utilities, water, 8in	6"	PVC	31+20.50	49.11	LT	35.03 29.28
TH-07	ABC Utilities, water, 10in	10"	CI	31+20.50	58.44	LT	35.1 29.15
TH-08	ABC Utilities, water, 8in	6"	PVC	20.22	67.03	LT	35.36 29.39
TH-09	ABC Utilities, water, 8in	6"	PVC	37+20.50	48.02	LT	30.74 24.99
TH-10	ABC Utilities, water, 10in	10"	CI	37+20.50	60.11	LT	30.73 24.87
TH-11	ABC Utilities, water, 8in	6"	PVC	37+20.50	71.02	LT	30.73 24.6
TH-12	ABC Utilities, water, 8in	6"	PVC	39+97.64	47.19	LT	33.16 26.14
TH-13	ABC Utilities, non-potable water, 10in	10"	CI	40+20.50	58.75	LT	33.13 25.59

- Append the applicable information from **Row 2** into **Row 1**. The data can be sorted by headers using the **Custom Sort** tool under the *Editing* tab. Each utility will need to be sorted by the test holes that correspond to them. The **Left Offset** values will need to have a minus sign (-) appended to them. The objective of this step is to organize the data by each utility which will help later when constructing the vertical geometry. **Save** the file in the **Roadway > eng_data** folder as a **CSV (Comma delimited) (*.csv)** and name it **22049555201_VerifiedUtilities.csv**.

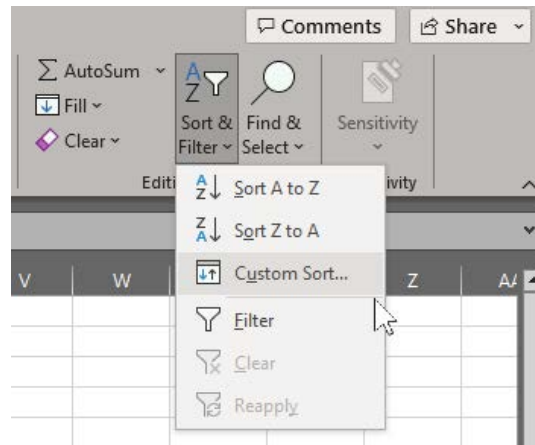

Vvh #	UTILITY DESCRIPTION (Owner, type)	SIZE	MATERIALS	US98 STATION	OFFSET	LT/RT	EXISTING GROUND ELEVATION	TOP ELEVATION
2	TH-01 ABC Utilities, Water Main	6"	PVC	25+20.33	-41.54	LT	36.73	30.98
3	TH-02 ABC Utilities, Water Main	6"	PVC	25+20.50	-70.70	LT	38.32	32.42
4	TH-03 ABC Utilities, Water Main	6"	PVC	26+70.37	-43.23	LT	35.89	30.29
5	TH-04 ABC Utilities, Non-Potable Water	10"	CI	26+69.98	-49.49	LT	36.41	30.66
6	TH-05 ABC Utilities, Water Main	6"	PVC	26+70.66	-61.20	LT	36.39	30.64
7	TH-06 ABC Utilities, Water Main	6"	PVC	31+20.50	-49.11	LT	35.03	29.28
8	TH-07 ABC Utilities, Non-Potable Water	10"	CI	31+20.50	-58.44	LT	35.1	29.15
9	TH-08 ABC Utilities, Water Main	6"	PVC	31+20.22	-67.03	LT	35.36	29.39
10	TH-09 ABC Utilities, Water Main	6"	PVC	37+20.50	-48.02	LT	30.74	24.99
11	TH-10 ABC Utilities, Non-Potable Water	10"	CI	37+20.50	-60.11	LT	30.73	24.87
12	TH-11 ABC Utilities, Water Main	6"	PVC	37+20.50	-71.02	LT	30.73	24.6
13	TH-12 ABC Utilities, Water Main	6"	PVC	39+97.64	-47.19	LT	33.16	26.14
14	TH-13 ABC Utilities, Non-Potable Water	10"	CI	40+20.50	-58.75	LT	33.13	25.59

Vvh #	UTILITY DESCRIPTION (Owner, type)	SIZE	MATERIALS	US98 STATION	OFFSET	LT/RT	EXISTING GROUND ELEVATION	TOP ELEVATION
TH-04	ABC Utilities, Non-Potable Water	10"	CI	26+69.98	-49.49	LT	36.41	30.66
TH-07	ABC Utilities, Non-Potable Water	10"	CI	31+20.50	-58.44	LT	35.1	29.15
TH-10	ABC Utilities, Non-Potable Water	10"	CI	37+20.50	-60.11	LT	30.73	24.87
TH-13	ABC Utilities, Non-Potable Water	10"	CI	40+20.50	-58.75	LT	33.13	25.59
TH-01	ABC Utilities, Water Main	6"	PVC	25+20.33	-41.54	LT	36.73	30.98
TH-02	ABC Utilities, Water Main	6"	PVC	25+20.50	-70.70	LT	38.32	32.42
TH-03	ABC Utilities, Water Main	6"	PVC	26+70.37	-43.23	LT	35.89	30.29
TH-05	ABC Utilities, Water Main	6"	PVC	26+70.66	-61.20	LT	36.39	30.64
TH-06	ABC Utilities, Water Main	6"	PVC	31+20.50	-49.11	LT	35.03	29.28
TH-08	ABC Utilities, Water Main	6"	PVC	31+20.22	-67.03	LT	35.36	29.39
TH-09	ABC Utilities, Water Main	6"	PVC	37+20.50	-48.02	LT	30.74	24.99
TH-11	ABC Utilities, Water Main	6"	PVC	37+20.50	-71.02	LT	30.73	24.6
TH-12	ABC Utilities, Water Main	6"	PVC	39+97.64	-47.19	LT	33.16	26.14

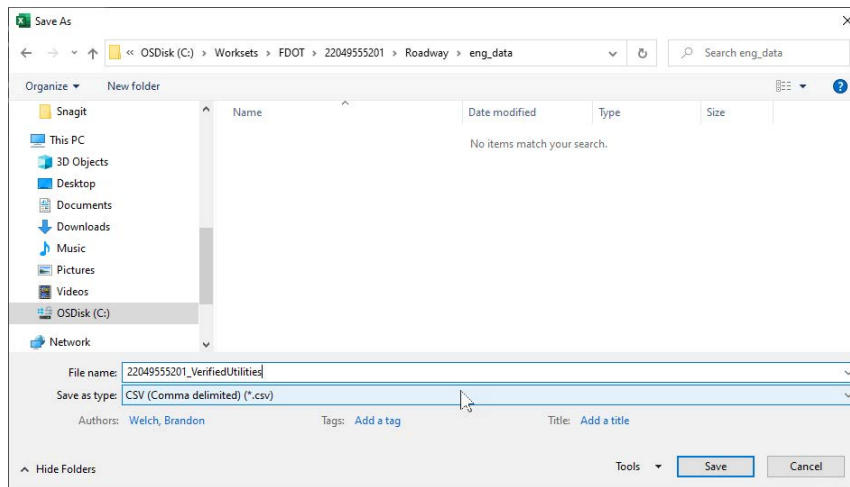

- Continue in the file *MODLRD_ExistingUtilities01.dgn*. **Detach** the reference *SURVRD01.dgn* from the *Default & Default-3D* views. Make the *Default* view active. **Attach** the file *ALGNRD01.dgn* from the project *Roadway* folder. On the *Geometry* tab of the ribbon, select **Import Horizontal Points From Ascii File** under the *Import/Export* drop-down in the *General Tools* group. Follow the *cursor prompt* and select the **US98** baseline. Navigate to the *Roadway>eng_data* folder, change the file type to **All Files (*.*)** and select the file *22049555201_VerifiedUtilities.csv*, then click **Done**.

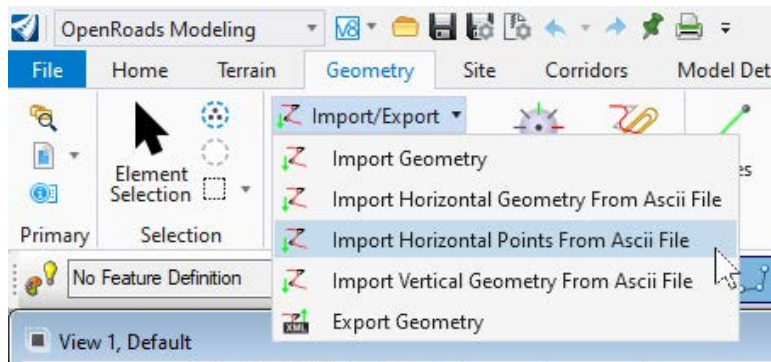

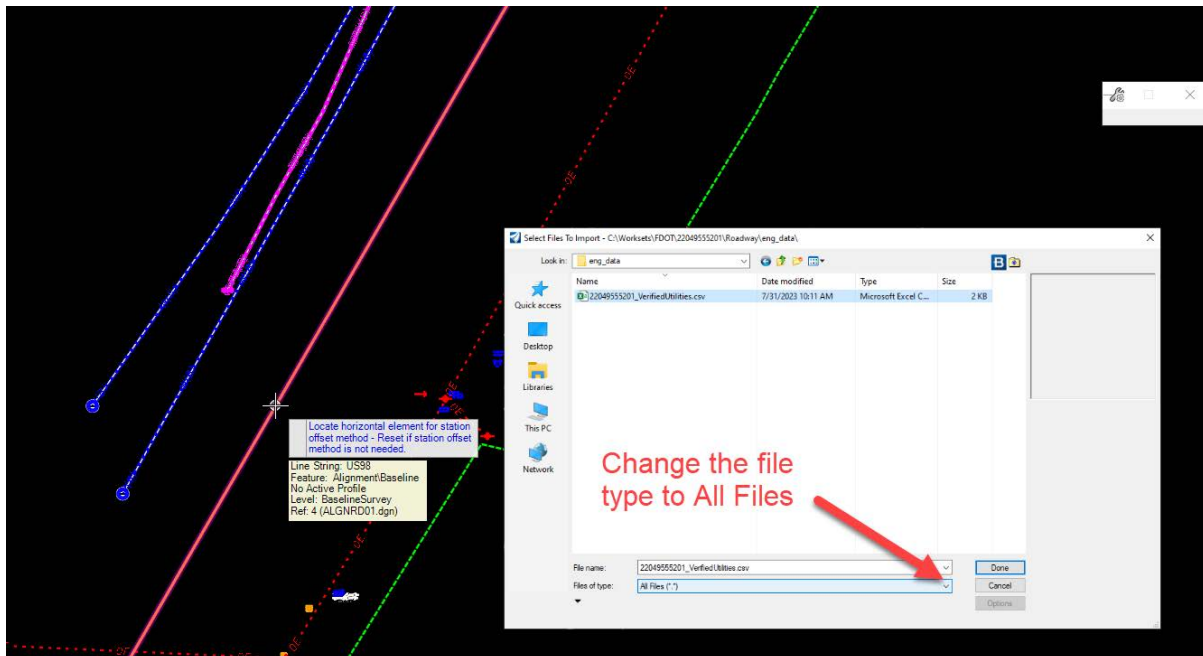

7. On the *Import Horizontal Points from ASCII File* dialog, click **Create new Text Import Settings File**.

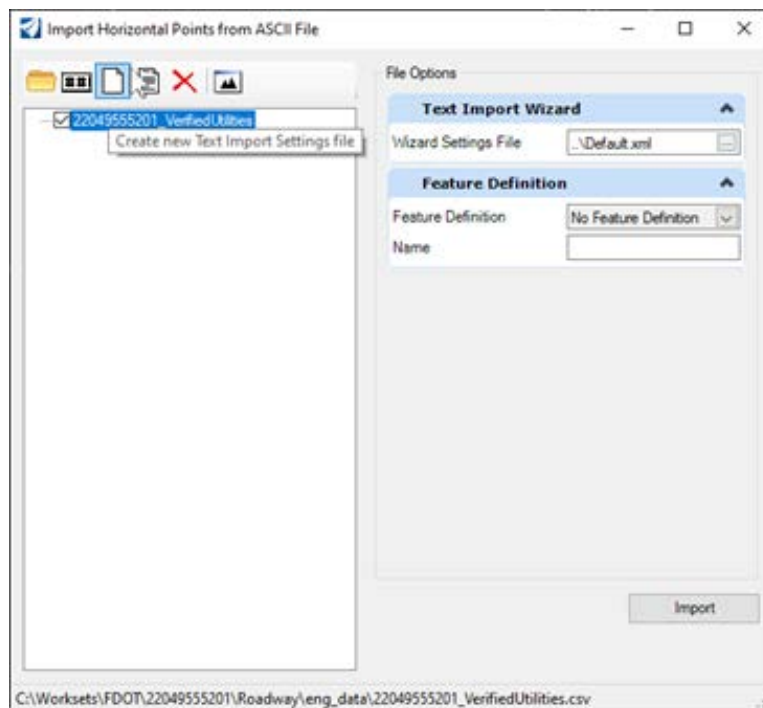

- On the *Create Text Import Settings File* dialog, under the *File Format* options, change *First line to import* to the correspond with where your test hole data starts. For this example, it is line **6**. Click **Next** to continue to the *Columns* options. Uncheck all *Column Delimiters* boxes except **Comma** and select each appropriate *column header* choosing the **Skip** option for the last 3 columns. What is most import here is the station and offset. Click **Next** and then **Finish**.

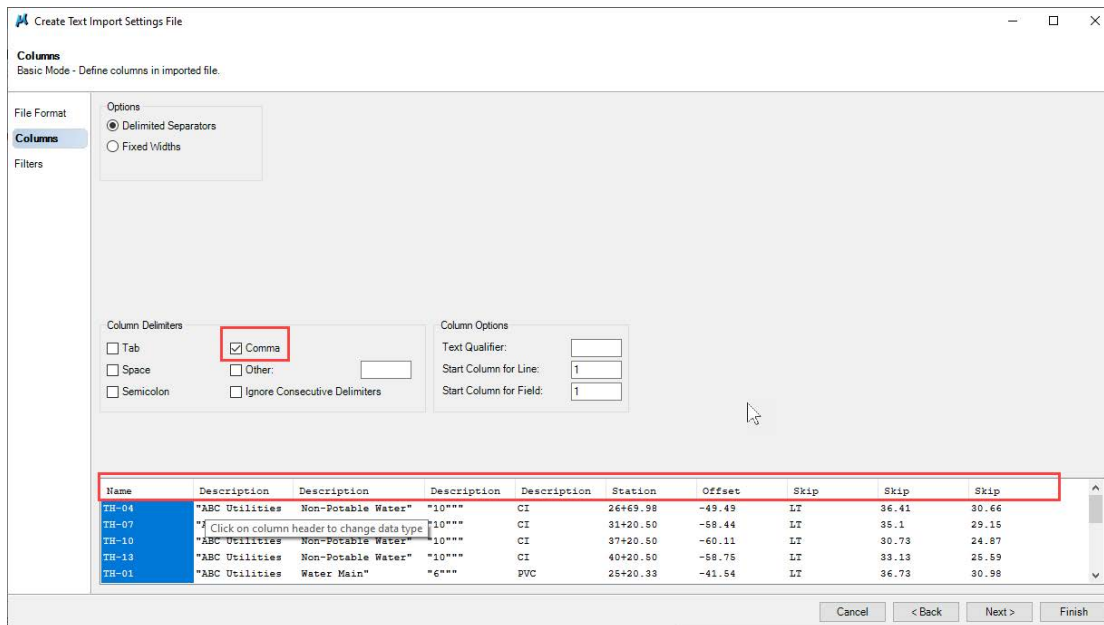
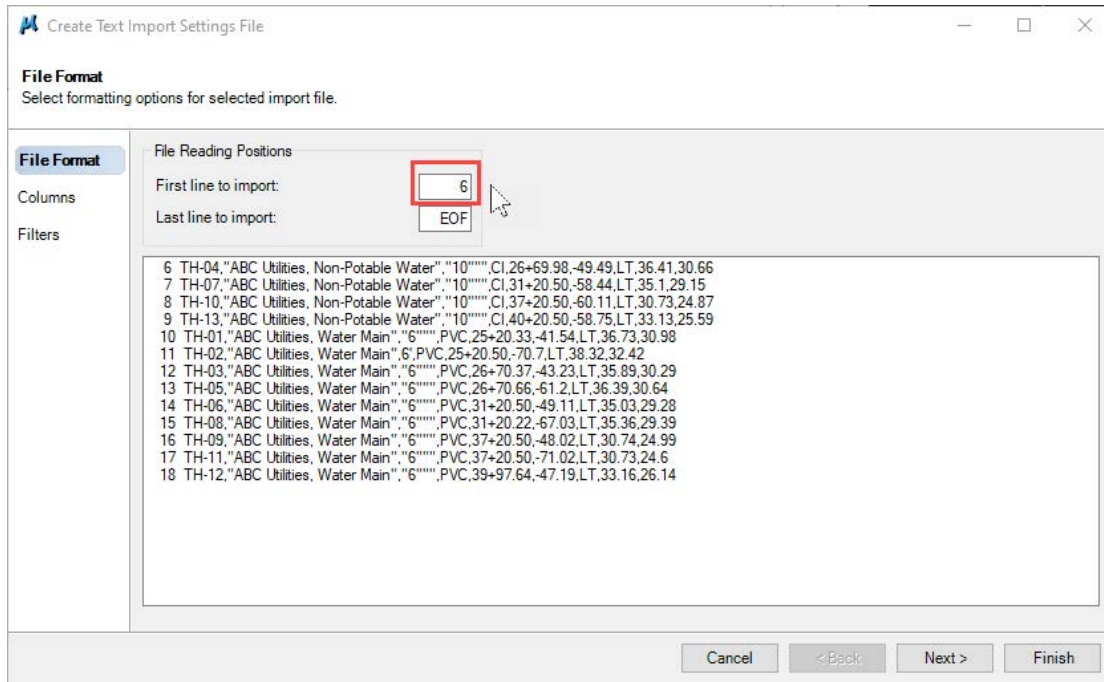

9. Save the file as *22049555201_VerifiedUtilities.xml* within the project *Roadway>eng_data* folder.

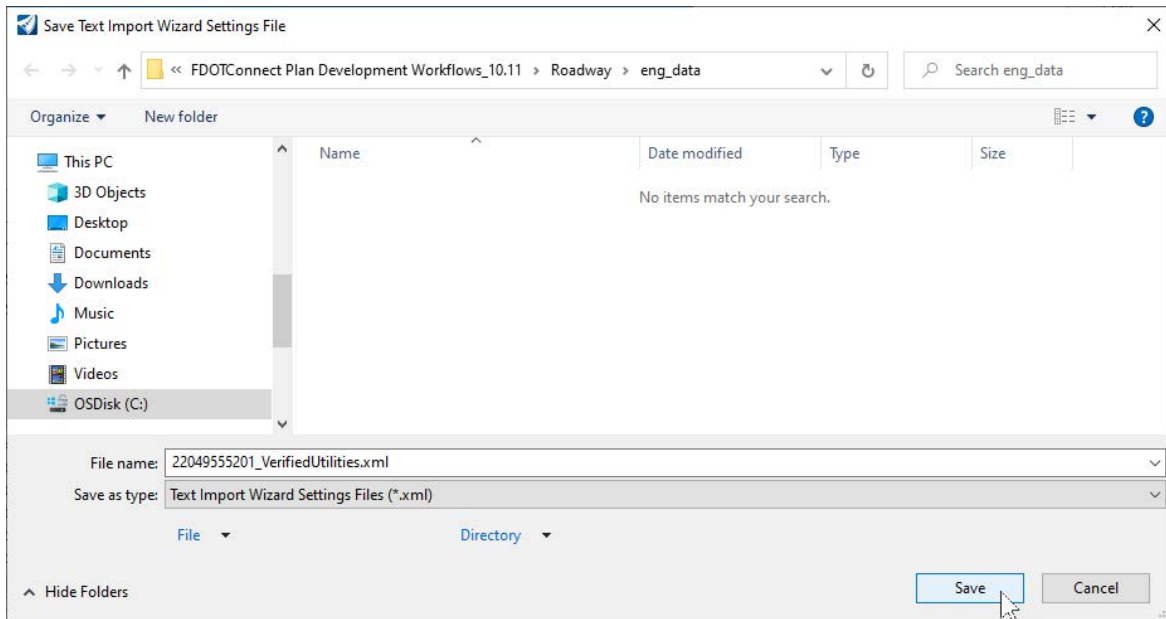

10. For the *Feature Definition* choose **ActivePoint** and click **Import**. Close the Import Horizontal Point from ASCII dialog. The imported points can be verified within **Explorer**.

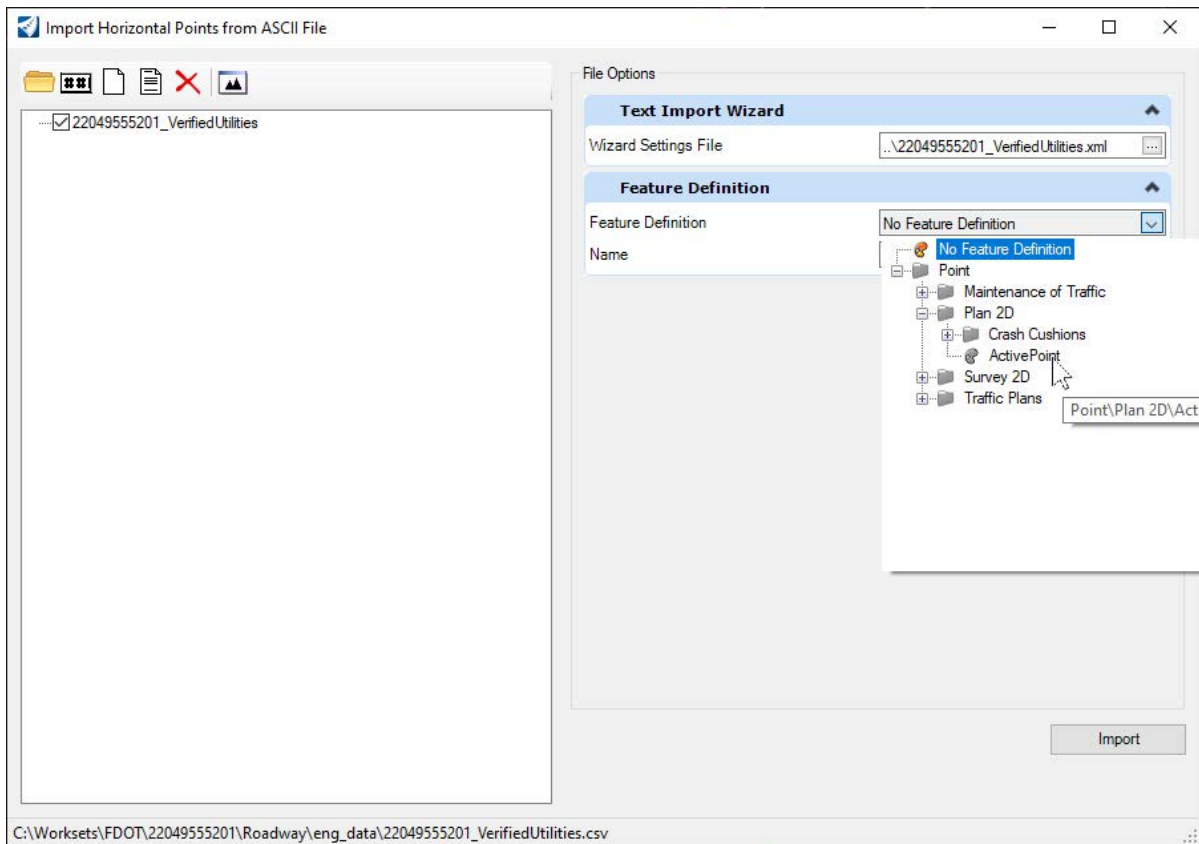

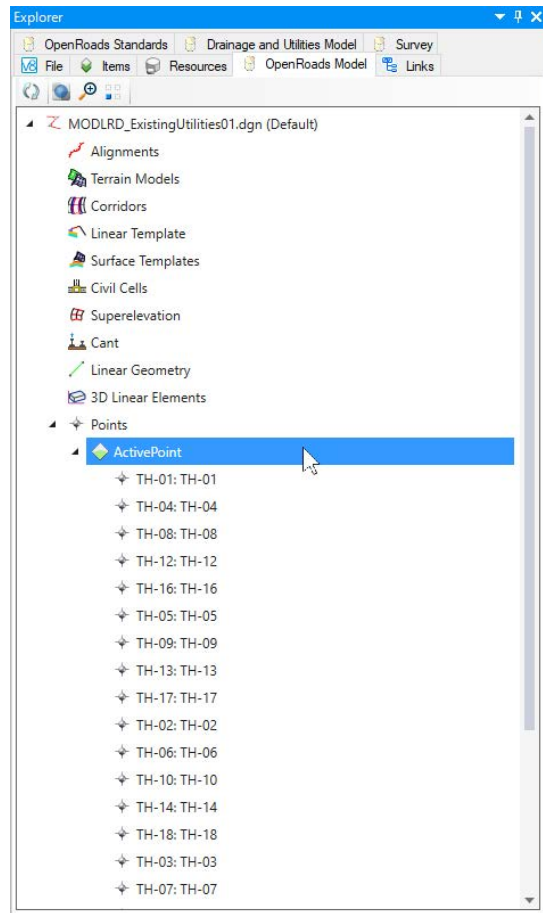

11. Open **2 Views Plan/Profile** using a long right click in the *Default* view. Click **OK** and select the existing **WaterB_ep** element closest to the alignment, then click into *View 4*.

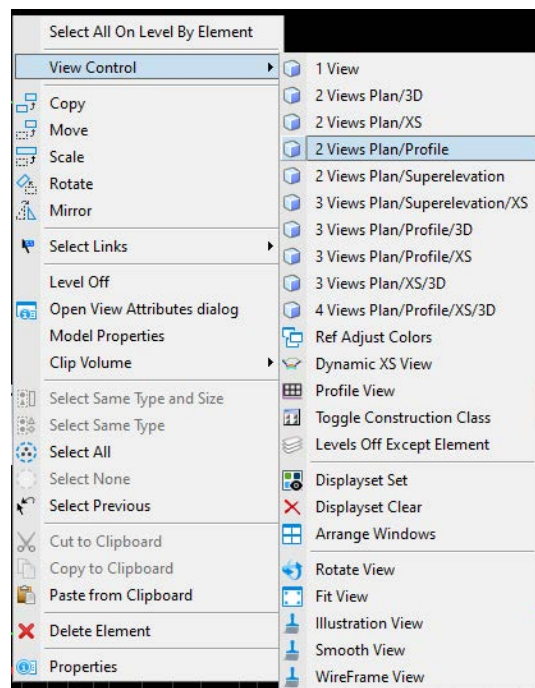

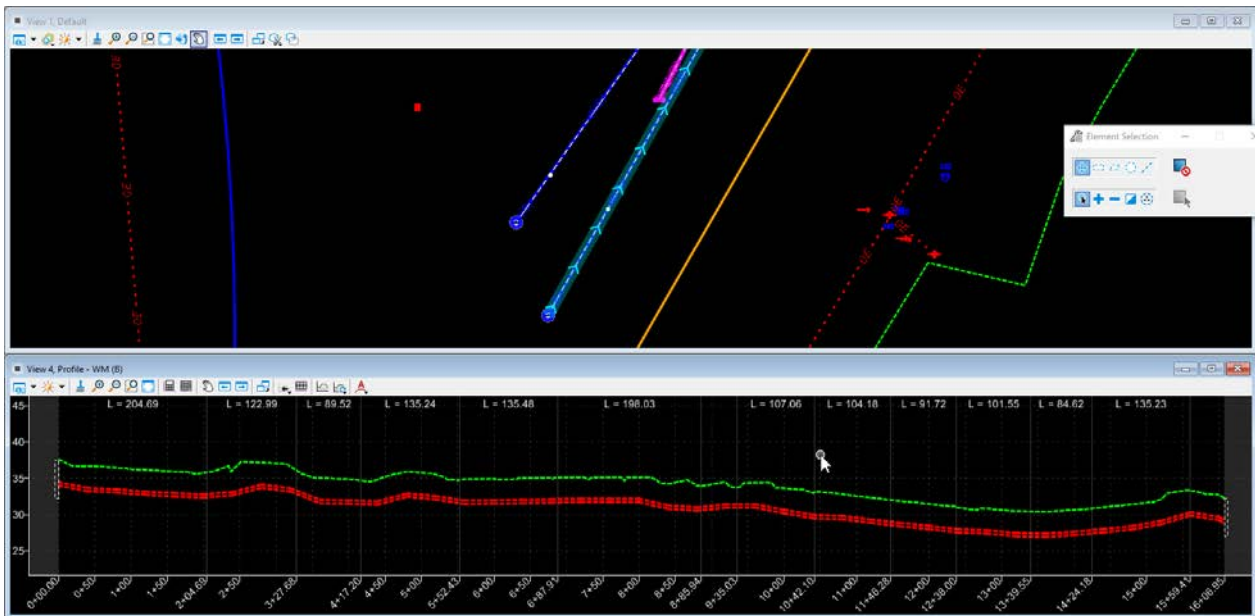

- On the *Geometry* tab, select **Profile Line Between Points** tool under the *Lines* drop-down in the *Vertical* group. Choose **Centerline** for the *Feature Definition*.

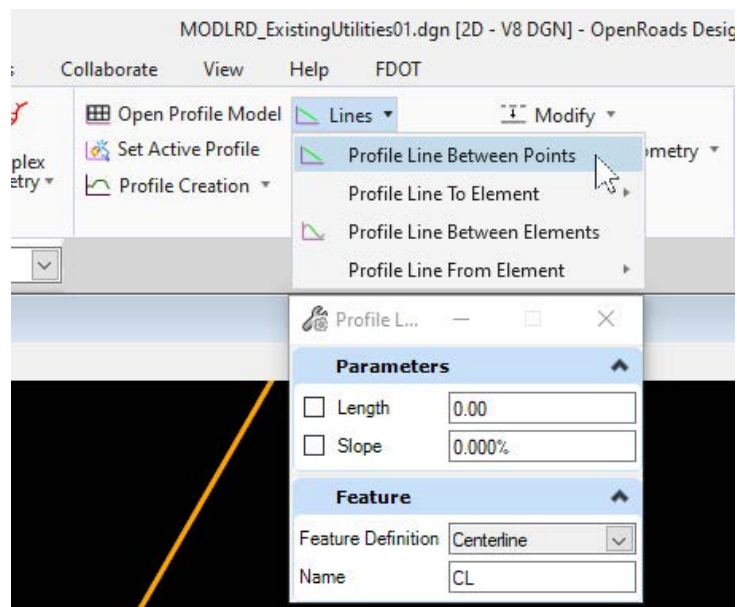

13. Activate **Civil Accudraw** with the “Z” option from the *Geometry* tab under the *Civil Toggles* drop-down in the *General Tools* group. The first icon toggles on/off.

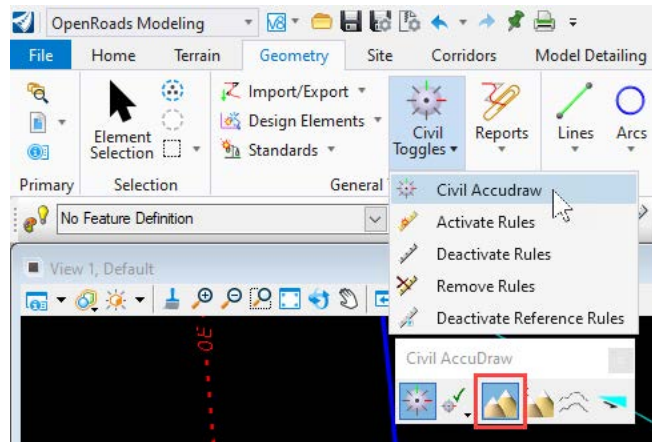

14. In the *Default* view, hover the cursor over the first imported point on the **WaterB_ep** line. Key **Enter** to lock the *Station* and for the *Z* value, enter the **Top Elevation Value** from the excel spreadsheet *22049555201_VerifiedUtilities.csv* that corresponds with the utility line. Data point to enter the **Start Point**. Locate the next horizontal point and key in the elevation value for the next Vvh test hole, data point to enter the **End Point**. Start the next line at the previous **End Point**.

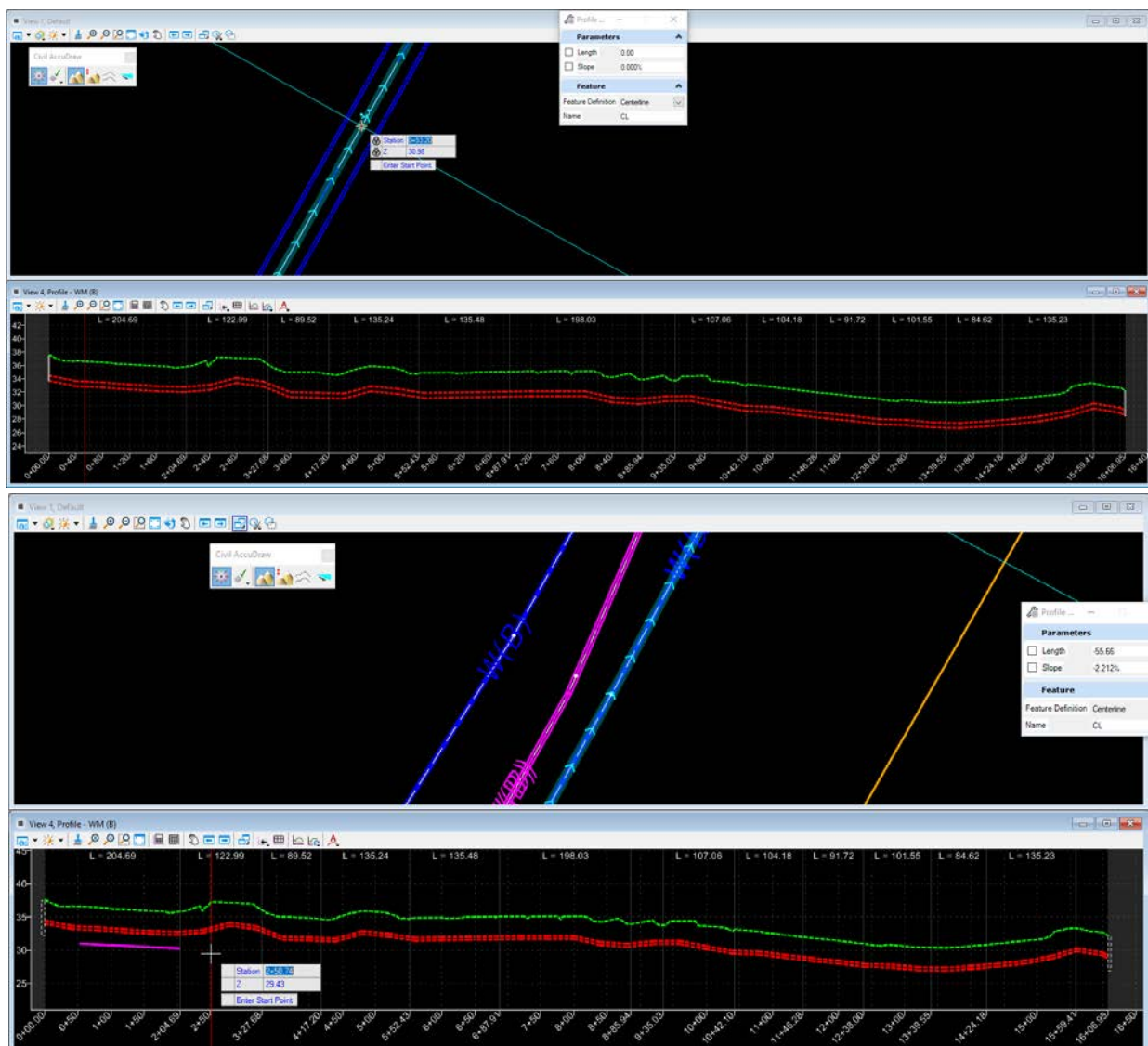

- Once the profile lines are drawn, Microstation *Modify* tools can be used to manipulate the linework. In order for the profile to get picked up correctly, the end points of the utility line work must be within the node shape as close to the original profile line. From there, the linework can be chained together with the **Profile Complex By Elements** tool on the *Geometry* tab, under the *Complex Geometry* drop-down in the *Vertical* group. Choose **Automatic** for the *Method* and **Centerline** as the *Feature Definition* and set the newly created line as the **Active Profile**.

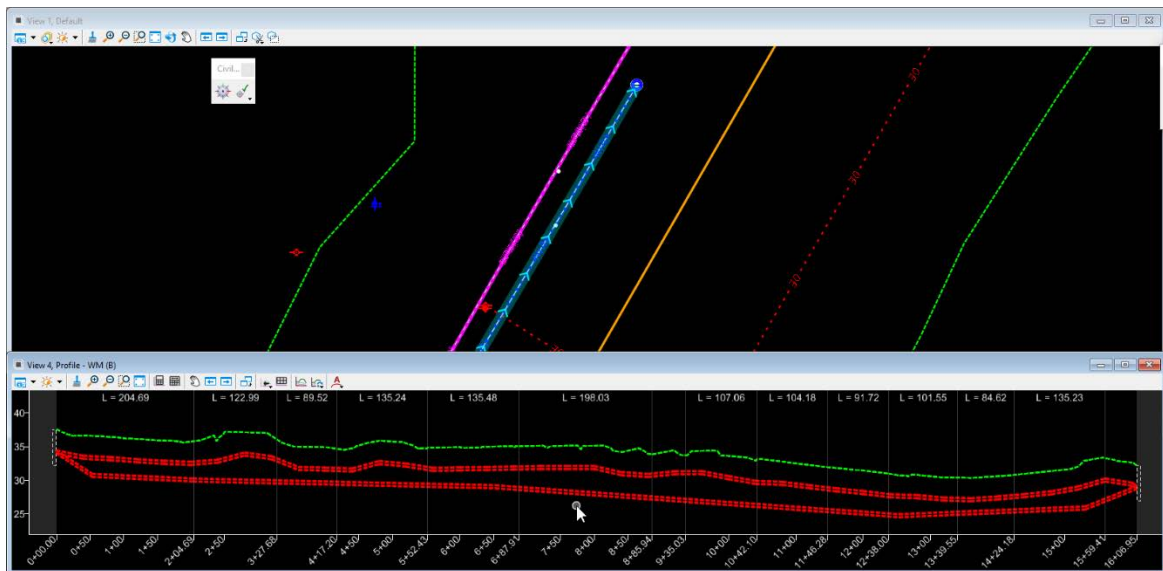
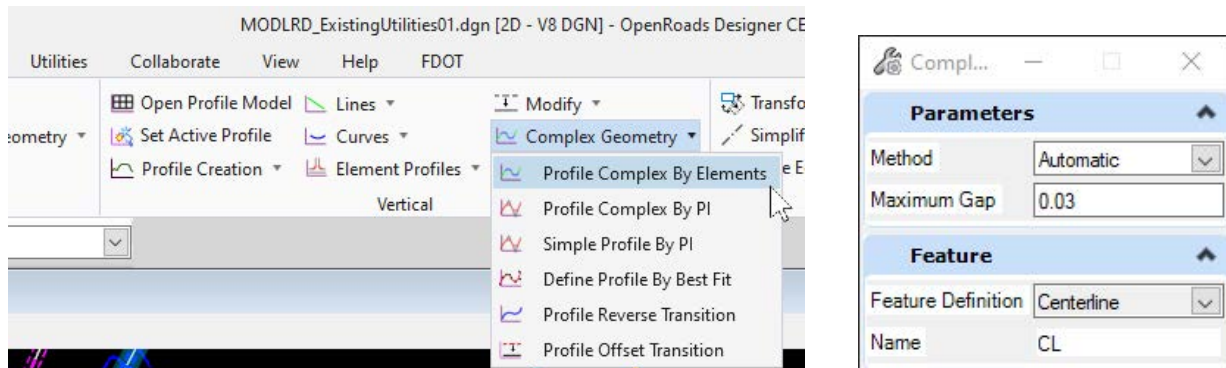

- Repeat steps 11-15 to plot the remaining Vvh information.

5 EXISTING DRAINAGE MODELING

INTRODUCTION

These exercises will introduce the workflow used to layout existing Drainage pipes and structures. The Drainage and Utilities workflow in OpenRoads Designer will be used and a SUDA and SUE database will be embedded into the file.

OBJECTIVE

Demonstrate workflow of creating the Existing Drainage

Create a 3D Existing Drainage model

Use the Extract From Graphic tool

EXERCISE OVERVIEW

Exercise 5.1	Create and set up a MODLRD_ExistingDrainage file.....	65
Exercise 5.2	Use the Extract From Graphic tool.....	68
Exercise 5.3	Show Existing Drainage in a Dynamic Cross Section.....	71

Exercise 5.1 Create and set up a MODLRD_ExistingDrainage file

1. Launch the **Create File** tool from the *FDOT* tab of the ribbon in the *Actions* group. Switch the *Discipline* to **Roadway** and the *File Group* to **Roadway Design Files**. Select the *Base Filename* **MODLRD** from the list. In the *Modifier (Optional)* field, type **_ExistingDrainage**. Select a **Coordinate System** for the file or select a **County** which automatically populates the coordinate system dropdown. Make sure all settings match the dialog below, and then click **Create - Open File**. Close the **Create File** tool.

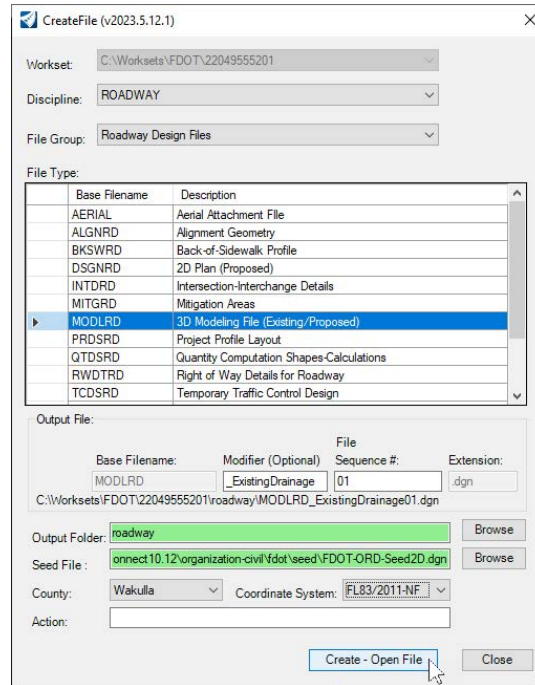

2. Navigate to the *Drainage and Utilities* workflow. On the *Layout* tab of the ribbon, select **Place Node** in the *Layout* group. A message will appear prompting to embed files for a Drainage and Utilities project. Click **Yes** and the file will process.

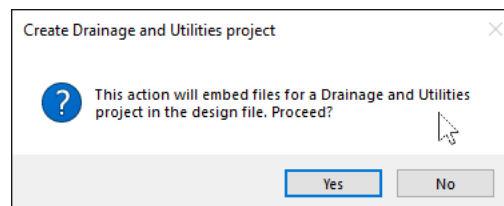
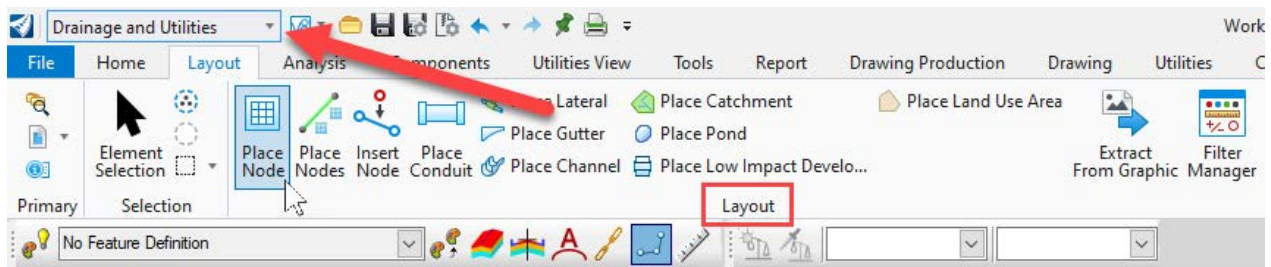

NOTE This action cannot be undone. The files become permanently embedded into the dgn.

3. Key **F9** to open the *References* dialog. **Attach** the file *GDTMRD01.dgn* from the project *Survey* folder. Set the *Existing Ground* as **Active**.

4. Attach the file *SURVRD01.dgn* from the project Survey folder.
5. Key **F10** to open the *Level Display*. Select the *SURVRD01.dgn* reference and choose **Filters** from the dropdown. In the *Name* list, click on **STANDARDS.DREXRD** to filter the level display of the 2D survey reference.
6. Key **F2** to open both the *Default* and *Default-3D* views and repeat step 4 in the 3D view to filter the level display of the 3D survey reference.

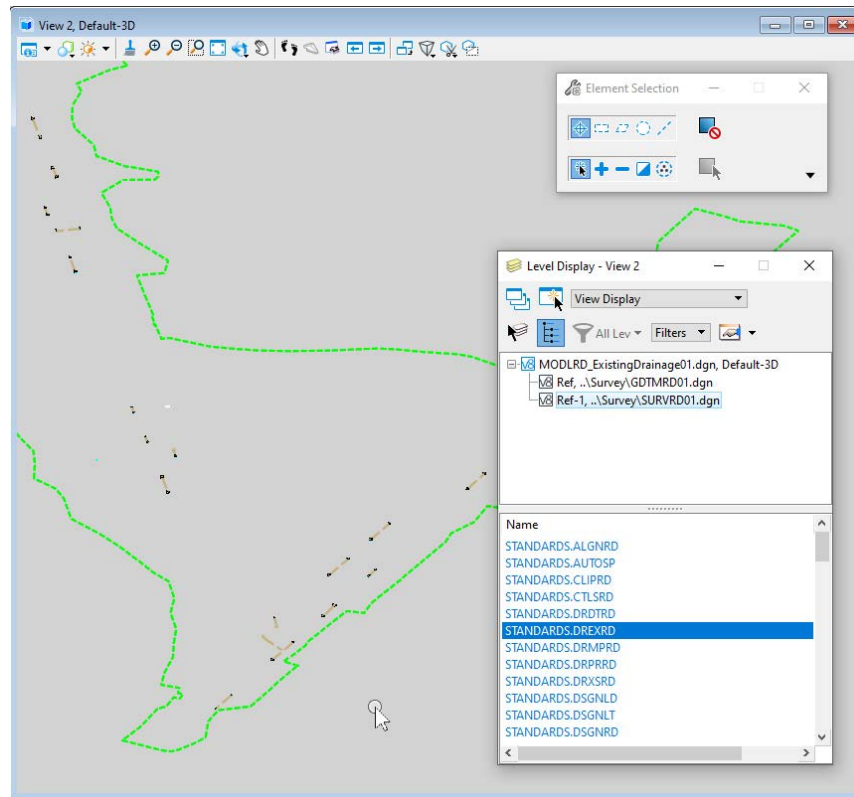

Exercise 5.2 Use the Extract From Graphic tool

1. On the *Layout* tab of the ribbon, select **Extract From Graphic** in the *Layout* group.

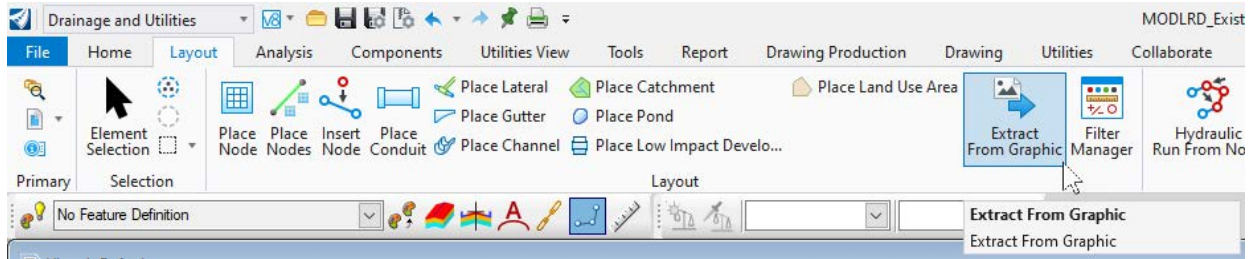

2. In the *Extract Utilities From Graphics* dialog, choose **Selection** for the *Method*, use **0.00** for the *Vertical Offset* and *Search Radius*, choose **Exist. Circular Pipes** for the *Feature Definition*, and **18 inch** for the *Description*. Select **ExMESS18RCP4S** for *Node Feature* (this is initially greyed out but becomes active after choosing a feature definition). Follow the *cursor* prompt to select the **PipeCulvert_ep** elements in the *Default* view. Once an element is selected, the *Use 3D Element Elevations?* tick box becomes available, tick it to make it active. Accept the *cursor prompts* to create the existing drainage pipes.

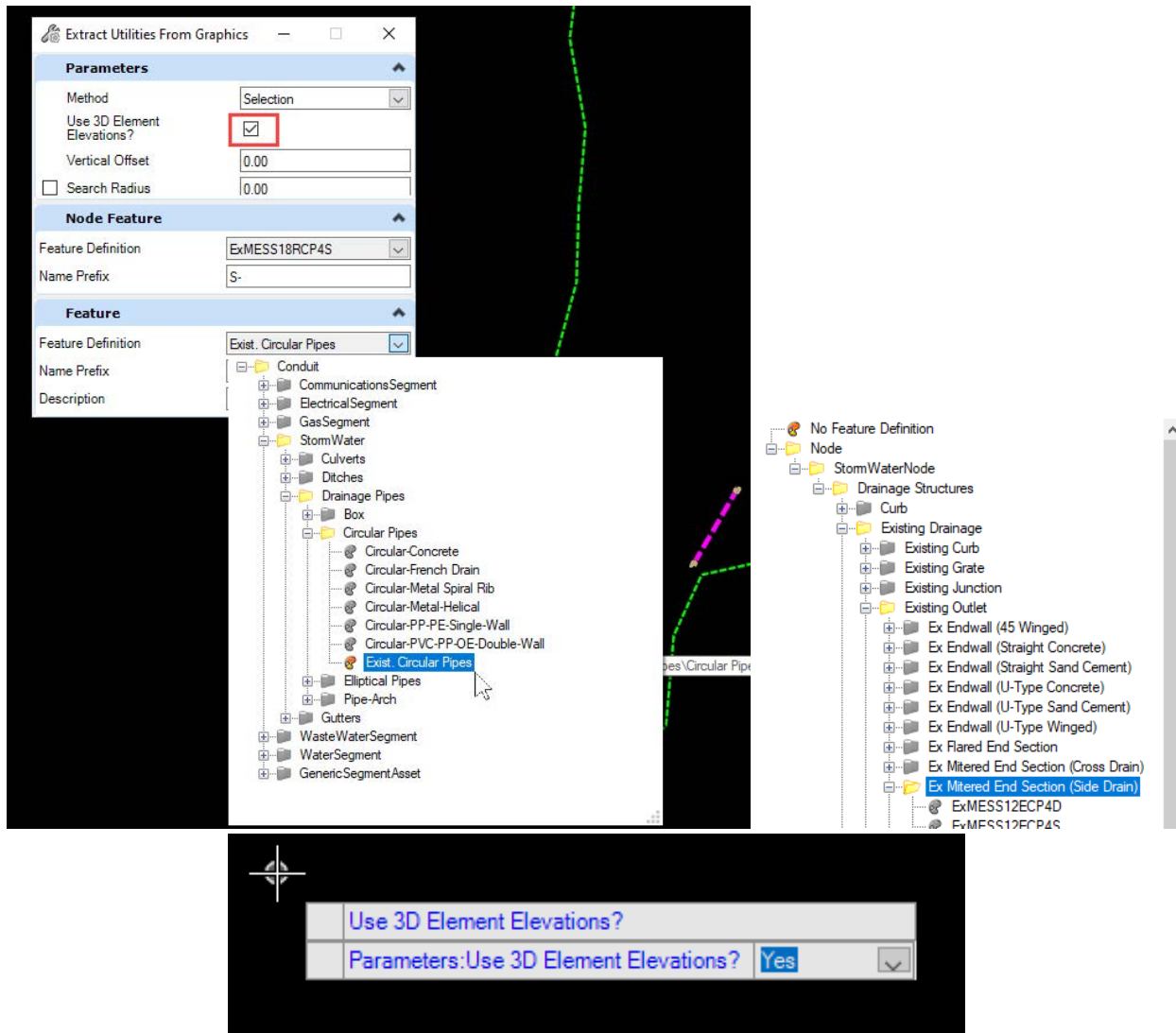

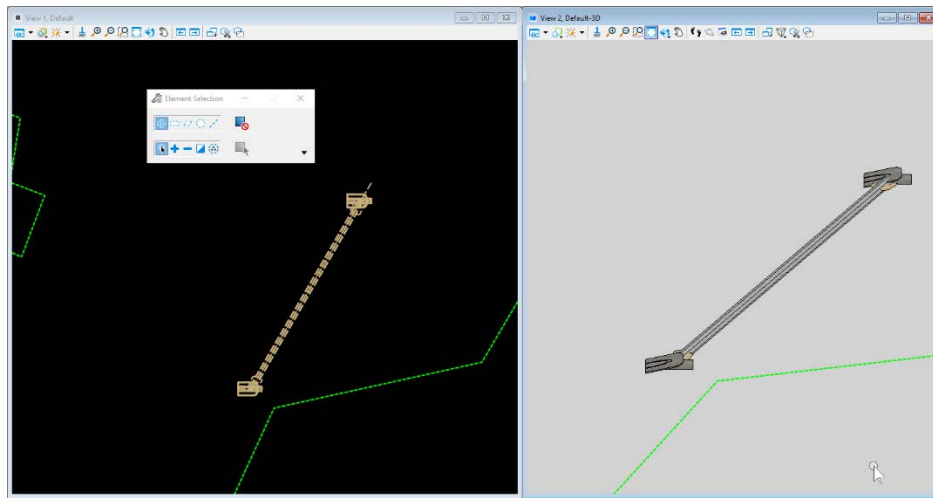

3. After the structures have been placed, the **Nodes** need to be rotated in order to align with the center of the structure. Highlight one of the drainage nodes and select the triangular **Rotation Handles** and snap on the center line of the pipe

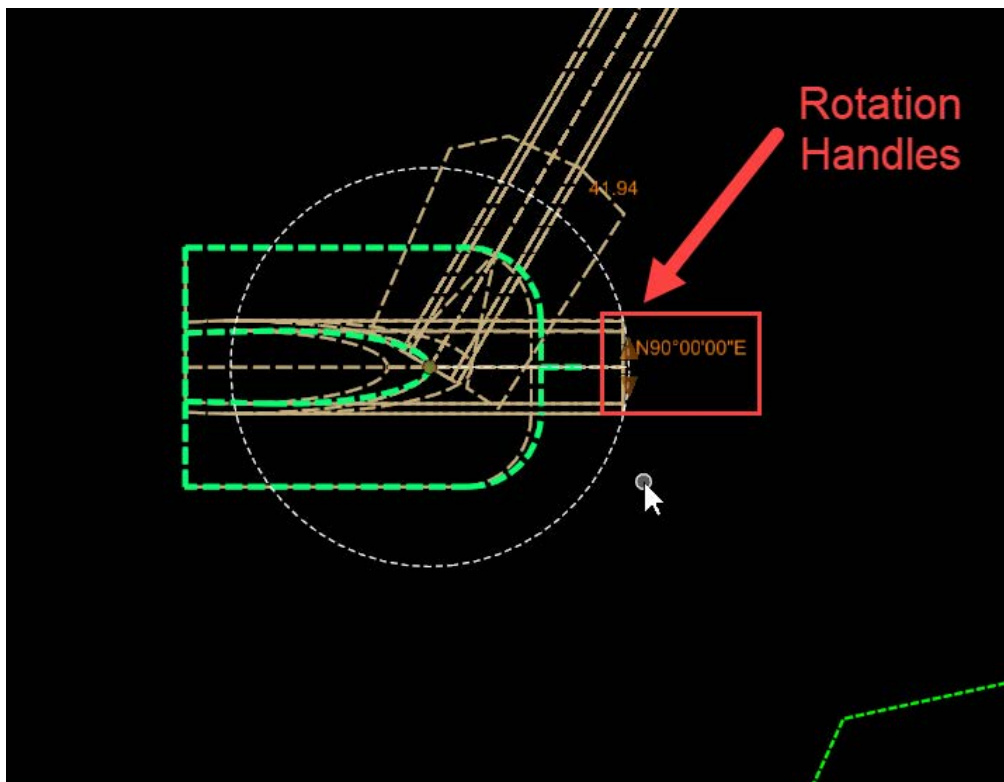

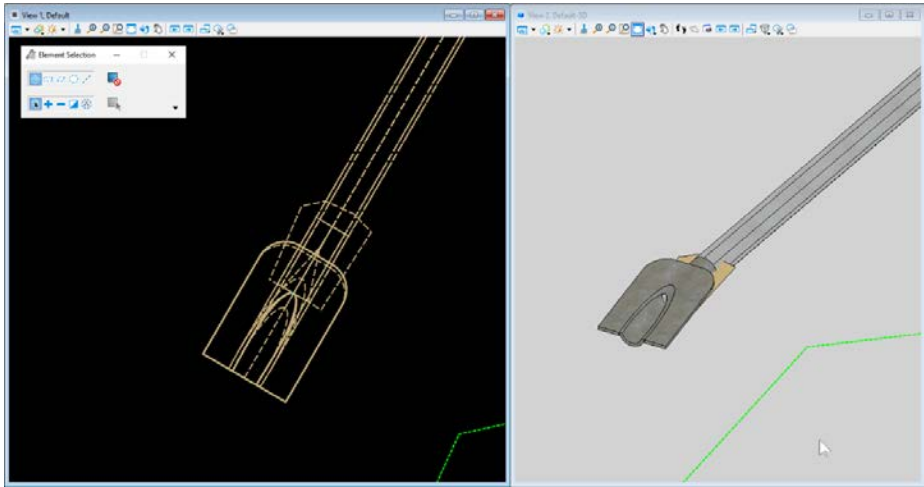
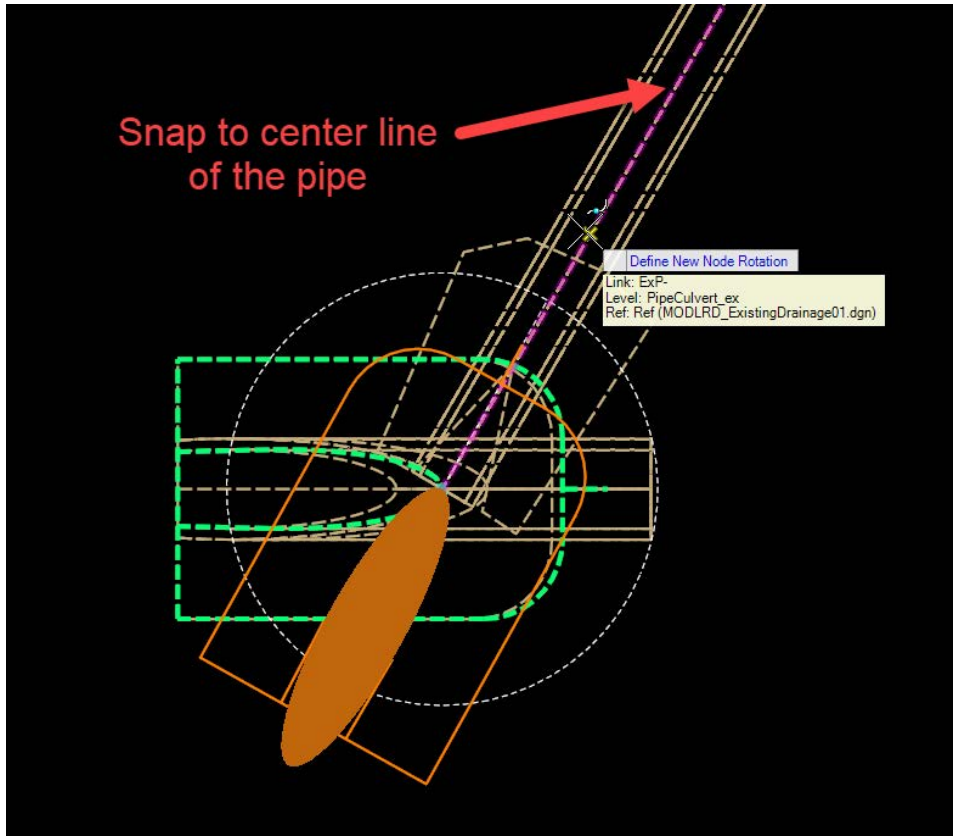

Exercise 5.3 Show Existing Drainage in a Dynamic Cross Section

1. Open the References dialog and Detach the file *SURVRD01.dgn* from the Default & Default-3D views.
2. Open the file *MODLRD_ExistingFeatures01.dgn* from the project Roadway folder.
3. Use the References dialog and Attach the file *MODLRD_ExistingDrainage01.dgn* to the Default view.
4. Switch to the OpenRoads Modeling workflow. On the Corridors tab, select Open **Cross Section View** under the Dynamic Sections drop-down in the Review group.
5. Follow the cursor prompt and select the US98 Baseline. Choose the Left & Right Offset, Station, and Interval values. Open View 4 and click inside to display the Dynamic Cross Section view.

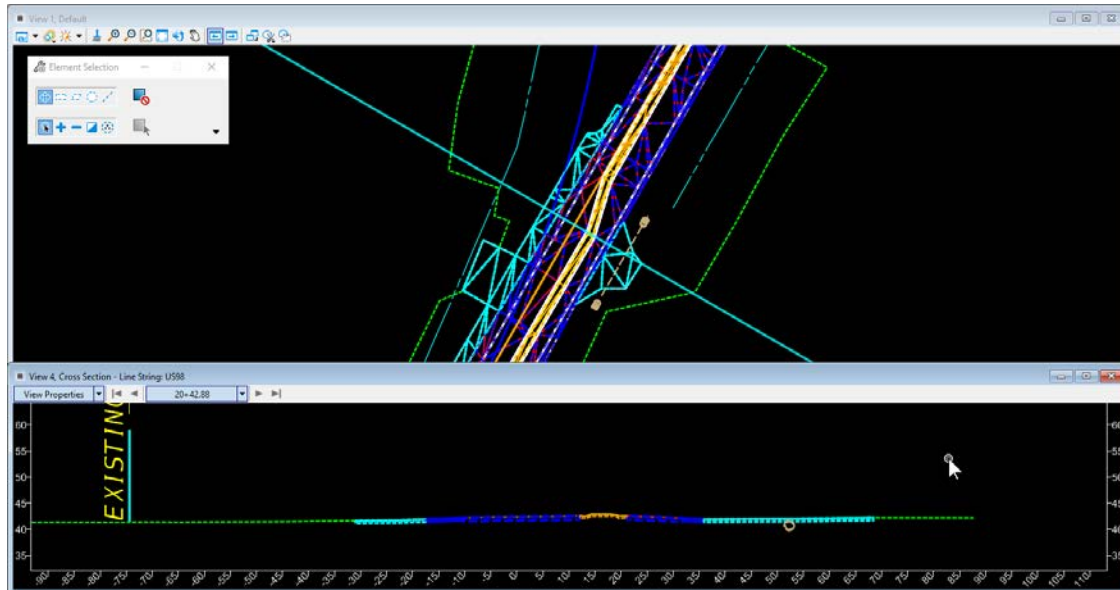

6 GEOTECH DATA MANAGER AND REPORT OF CORE BORINGS SHEETS

INTRODUCTION

This chapter will introduce the FDOT tools to load Borehole data into the Geotech Data Manager and create 2D and 3D models as well as the Report of Core Boring Sheets needed for plans.

OBJECTIVE

Demonstrate workflow of importing data into the Geotech Data Manager.

Create 2D and 3D models for use in viewing Borehole data.

Create the Report of Core Borings Plan Sheets.

EXERCISE OVERVIEW

Exercise 6.1	Create and set up a ABORRD file.....	73
Exercise 6.2	Review delivered GeotechDataSheetTemplate.xlsx spreadsheet.....	75
Exercise 6.3	Import delivered Geotech Data Template into the Geotech Data Manager.....	78
Exercise 6.4	Place Boreholes tool to create 2D and 3D models of Geotechnical Data.....	81
Exercise 6.5	Create an Event Points List in the ALGNRD file.....	84
Exercise 6.6	Create a RDXSRD file to show Borehole information in Cross Sections.....	86
Exercise 6.7	Use the Report of Borings tool to create the Report of Core Borings Sheet.....	90
Exercise 6.8	Create a Soil Survey Sheet for plans.....	94

Exercise 6.1 Create and set up a ABORRD file

1. This is an optional step, only needed if the SR61_CL centerline feature is not present in the ALGNRD file. Open the file ALGNRD01.dgn from the project Roadway folder. On the Geometry tab select **Import Geometry** from the Import/Export drop-down in the General Tools group. Select All Alignments.xml in the project Roadway folder and click **Open**.
2. Select the **SR61_CL** tick box under the Alignment\Centerline tree and click **Import**.

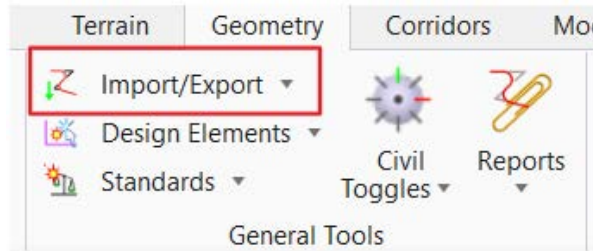

3. Launch the **Create File** tool from the *FDOT* tab of the ribbon in the *Actions* group. Switch the *Discipline* to **Roadway** and the *File Group* to **Geotechnical Design Files**. Select the *Base Filename* **ABORRD** from the list. Select a **Coordinate System** for the file or select a **County** which automatically populates the coordinate system dropdown. Make sure all settings match the dialog below, and then click **Create - Open File**. Close the **Create File** tool.

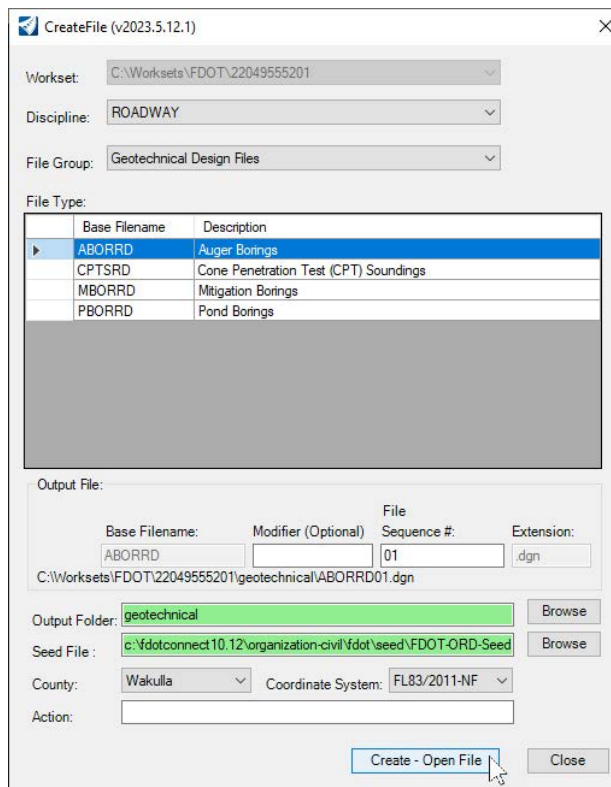

4. Key **F9** to open the *References* dialog. **Attach** the file ALGNRD01.dgn from the project Roadway folder and the GDTMRD01.dgn file from Survey folder. Fit the view and set the *Existing Ground* terrain **Active**.
5. Key **F2** to open the *Default* and *Default-3D* views side by side. Make the *Default-3D* view active and **Attach** the *Default* model of the ALGNRD01.dgn file from the project Roadway folder with a logical name of **ALGNRD-2D**. Turn off the display of the ALGNRD01.dgn *Default-3D* reference.

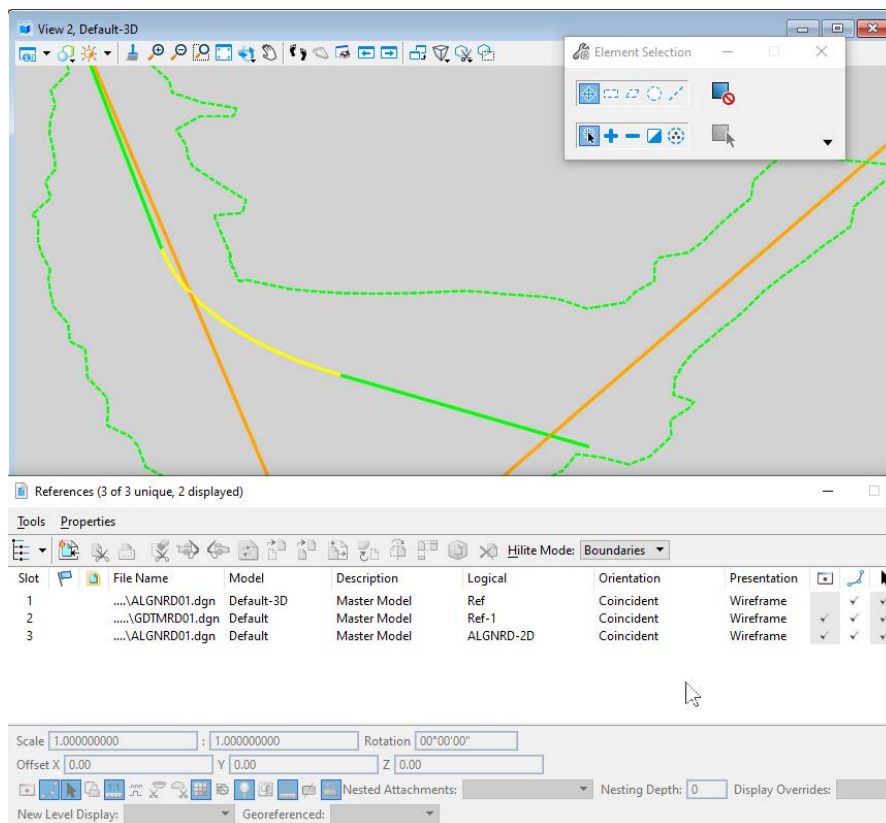
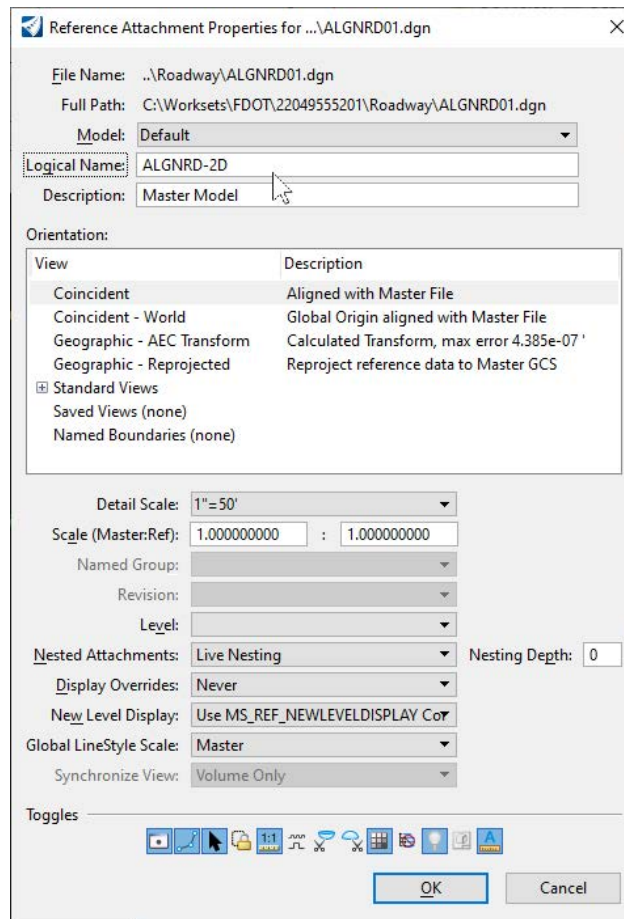

Exercise 6.2 Review delivered GeotechDataSheetTemplate.xlsx spreadsheet

1. From the *FDOT* tab, click **Explore Directories** in the *Resources* group. Open the excel workbook *GeotechDataSheetTemplate.xlsx* to examine the contents. This workbook can be modified per project.

NOTE The Excel spreadsheet is just one way of importing data from a database or is used for those that prefer to work in Excel.

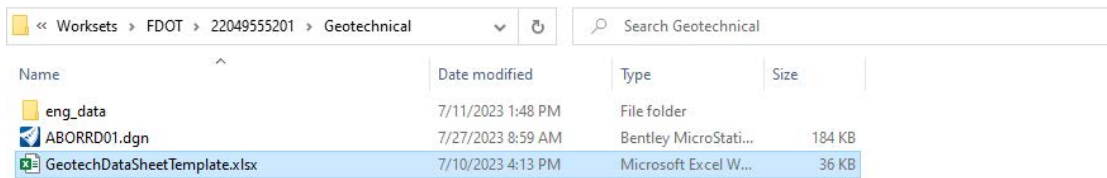

Name	Date modified	Type	Size
eng_data	7/11/2023 1:48 PM	File folder	
ABORRD01.dgn	7/27/2023 8:59 AM	Bentley MicroStati...	184 KB
GeotechDataSheetTemplate.xlsx	7/10/2023 4:13 PM	Microsoft Excel W...	36 KB

selected 35.7 KB

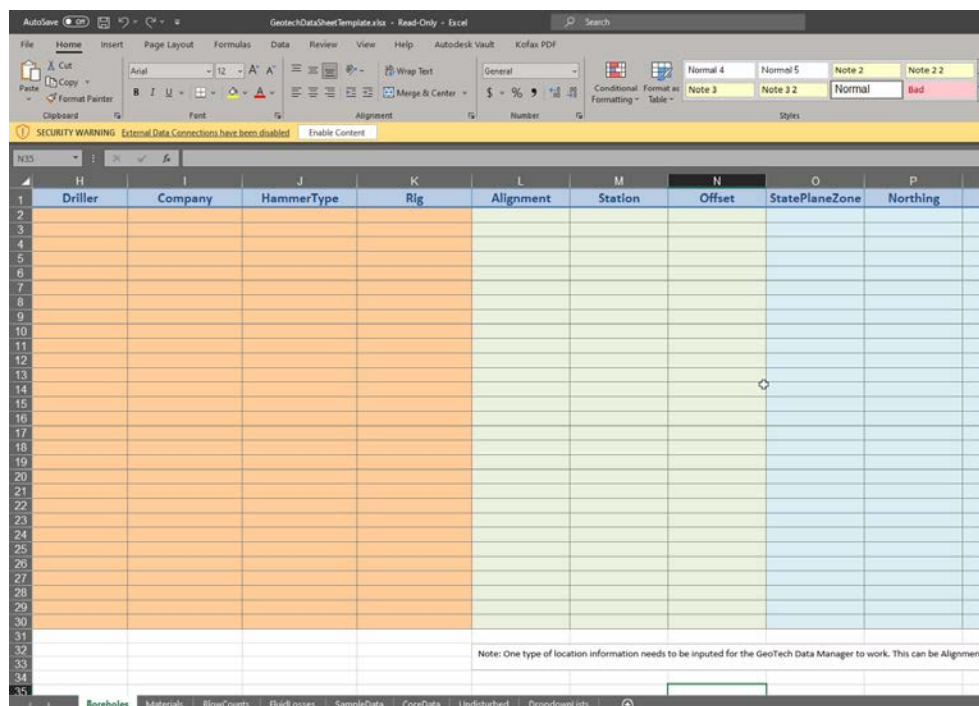

SECURITY WARNING: External Data Connections have been disabled. Enable Content

	H	I	J	K	L	M	N	O	P
1	Driller	Company	HammerType	Rig	Alignment	Station	Offset	StatePlaneZone	Northing
2									
3									
4									
5									
6									
7									
8									
9									
10									
11									
12									
13									
14									
15									
16									
17									
18									
19									
20									
21									
22									
23									
24									
25									
26									
27									
28									
29									
30									
31									
32									
33									
34									
35									

Note: One type of location information needs to be inputted for the GeoTech Data Manager to work. This can be Alignment.

- The following are 7 tabs in the example spreadsheet that will need Geotech data entered in: **Boreholes**, **Materials**, **BlowCounts**, **FluidLosses**, **SampleData**, **CoreData**, **Undisturbed**. The appropriate information depending on the *Borehole Type* will be filled out in the other tabs of the spreadsheet. The **DropDownLists** tab will be ignored.

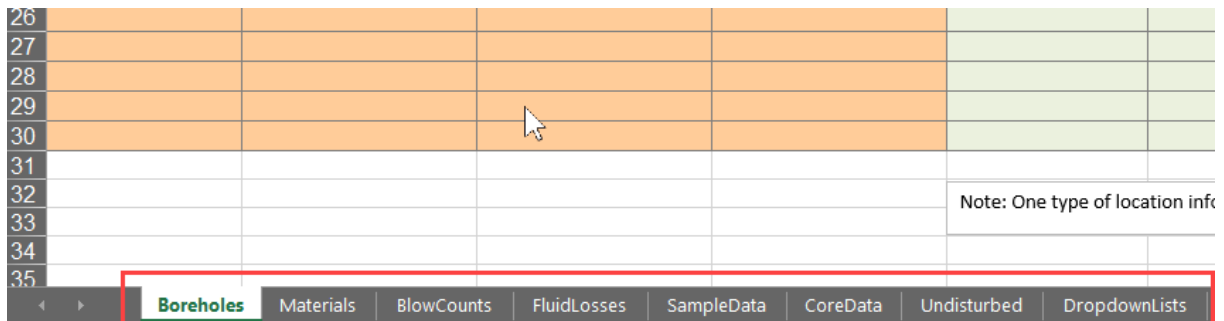

- On the **Boreholes** tab, applicable information is filled in each column from left to right. *BoreholeType* & *Vertical Datum* are dropdown lists, other columns will need to be filled in manually.

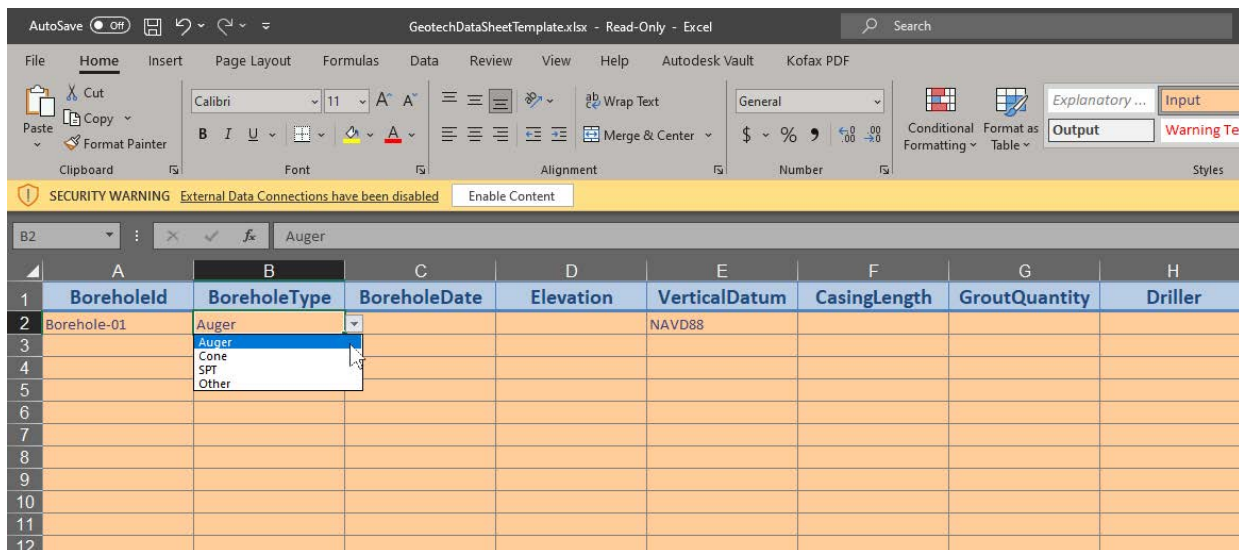

NOTE One type of location information needs to be input for the Geotech Data Manager to work. Each Borehole should only contain one type of location data (Station, State Plane, or Latitude/Longitude). If there is more than one type of location data for a single Borehole, the other location data will be recalculated when the Borehole symbol is placed in the drawing. The Column Headers must not be changed. Columns can be added, but the Geotech Data Manager will ignore them.

4. On the **Materials** tab, *Stratum* information will be entered for each Borehole. *AASHTO*, *USCS*, and *SoilPattern* are dropdown lists, other columns will need to be filled out manually. The other tabs will be filled out if applicable.

	D	E	F	G	H	I
	Depth	AASHTO	USCS	SoilDescription	SoilPattern	
1						
2						
3						
4						
5						
6						
7						
8						
9						
10						
11						
12						
13						
14						
15						
16						
17						
18						
19						
20						
21						
22						
23						
24						
25						
26						
27						

Dropdown menu for SoilPattern:

- None (Cavity)
- Asphalt
- Clay
- ClayeyGravel
- ClayeySand
- ClayeySilt
- Concrete
- Coquina

Software tabs: Boreholes, **Materials**, BlowCounts, FluidLosses, SampleData, CoreData, Undisturbed, DropdownLists

Exercise 6.3 Import delivered Geotech Data Template into the Geotech Data Manager

Included in the dataset is a pre-filled workbook containing the boring information to be plotted. This workbook will be imported in the Geotech Data Manager (GDM) and an .xml file will be exported.

1. From the *FDOT* tab, launch the **Geotech Data Manager** from the *Geotechnical* group.

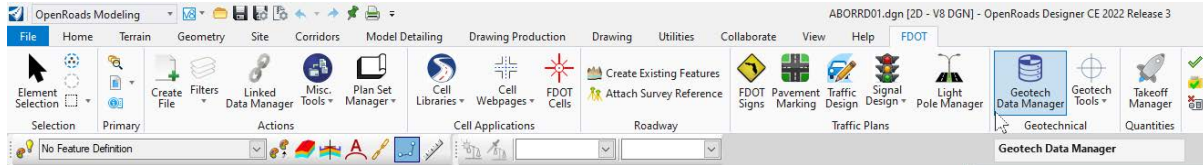

2. Once the tool opens, click **File > Import > Borehole Data Sheet** and open the file *22049555201_GeotechDataSheetTemplate.xlsx* from the *Geotechnical* project folder. The *Borehole Navigator Sheet* & *SPT Sheet* import options are considered legacy formats.

NOTE The legacy import options require additional changes to the formatting, contact the CADD office for more information.

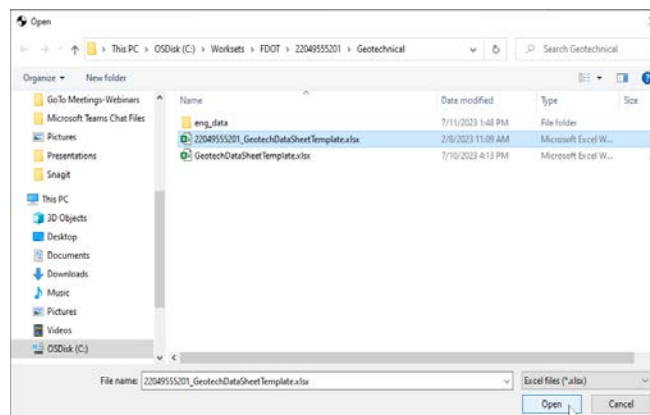
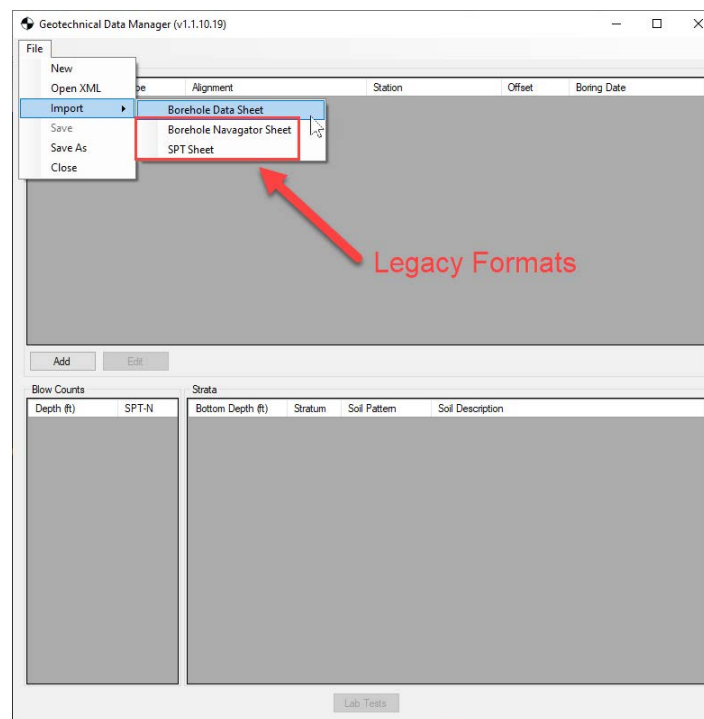

- There will be a **Warning!** message displayed when importing this file, click **OK** to ignore and see the borehole data. Use the **Add & Edit** buttons to add a new borehole or edit an imported one. Spreadsheets are not necessary to create a borehole database since all options for creating boreholes are included within the **Geotech Data Manager**. Click **Save** after making any changes.

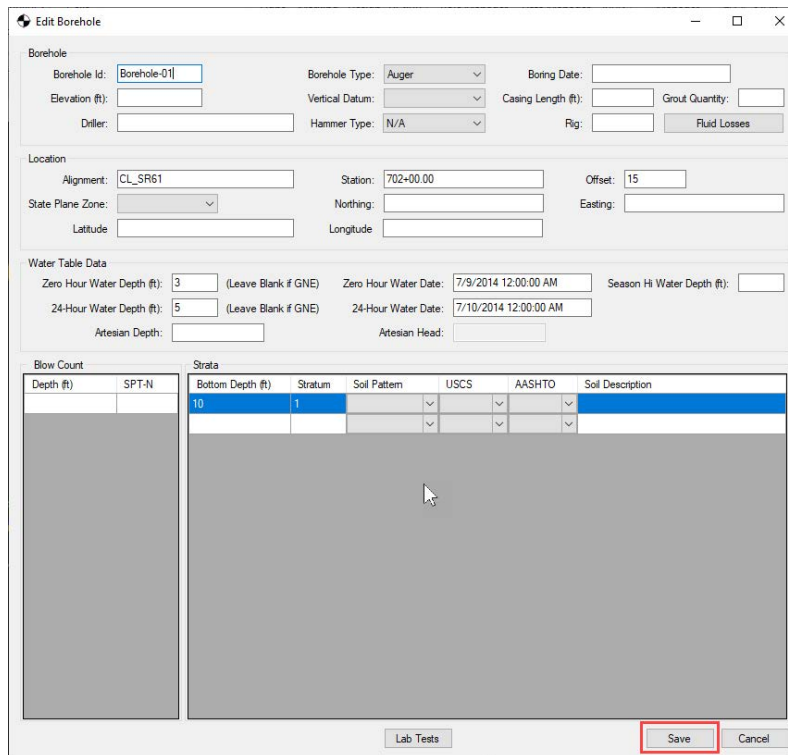
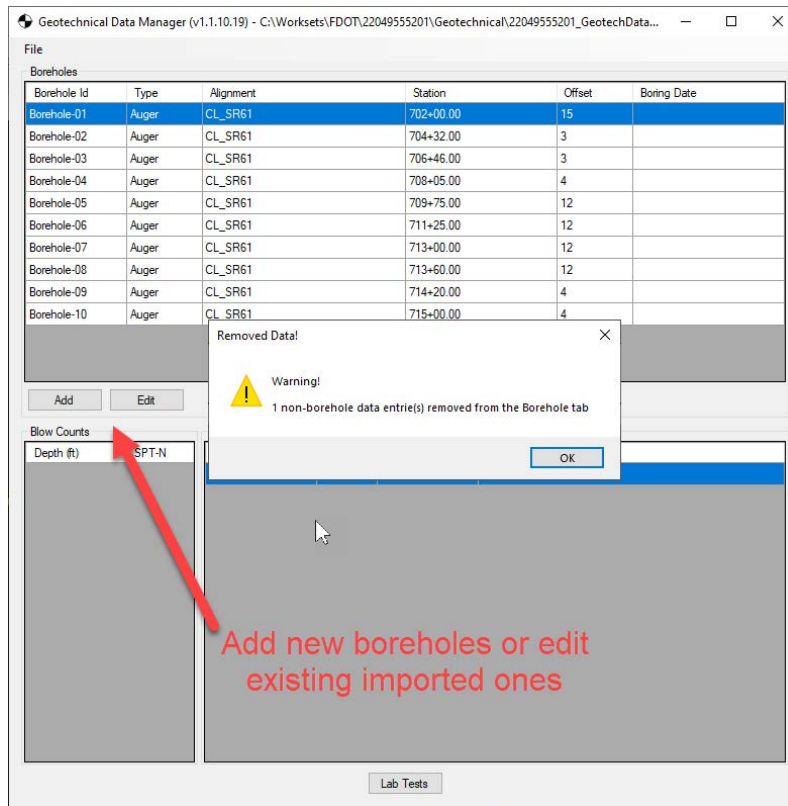

4. Click **File > Save As** and save the file in the *Geotechnical* folder appended with the *FPID* of the project *22049555201_Boreholes.xml*. **Close** the tool

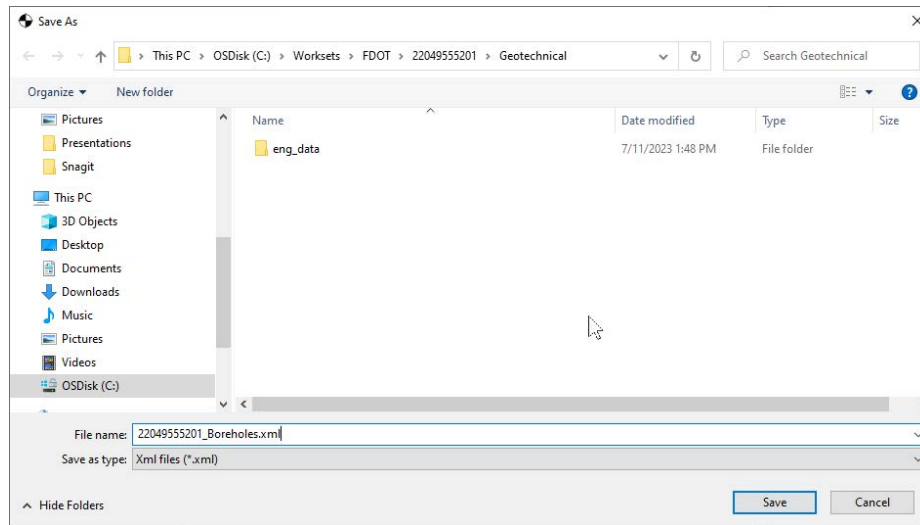

Exercise 6.4 Use the Place Boreholes tool to create 2D and 3D models of Geotechnical Data

1. Make *Default* view active. On the *FDOT* tab, select **Place Boreholes In 2D Plan** from the *Geotech Tools* drop-down under the *Geotechnical* group. Select the **Use Surface Elevation** option and **Existing Ground** from the drop-down. Click the *Browse* button to select the file *22049555201_Boreholes.xml* from the project *Geotechnical* folder and click **Open**.

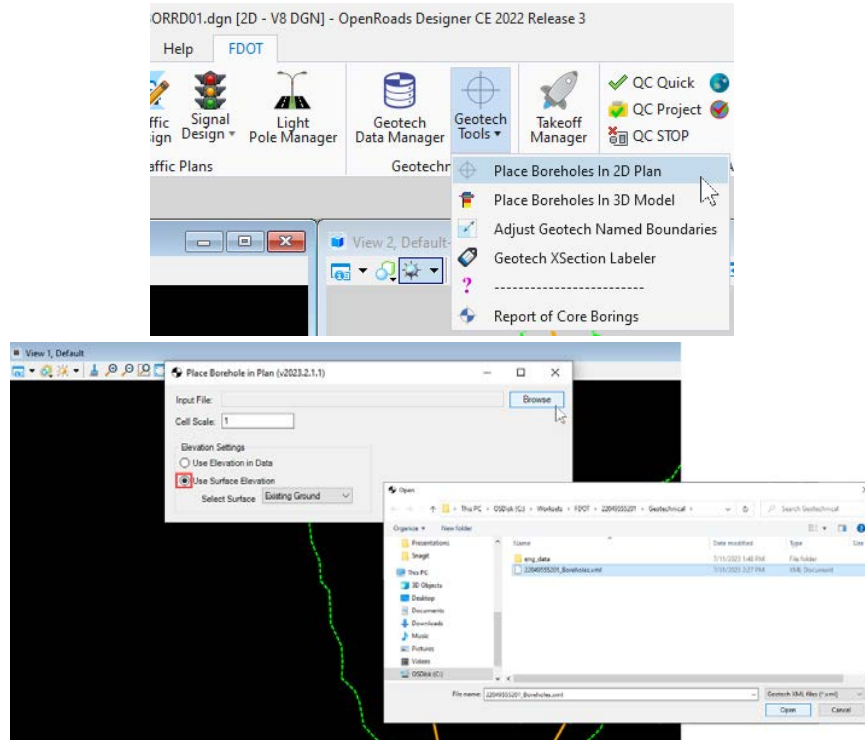

2. Once the file has been loaded, click **OK** to plot the boreholes in the *Default* view.

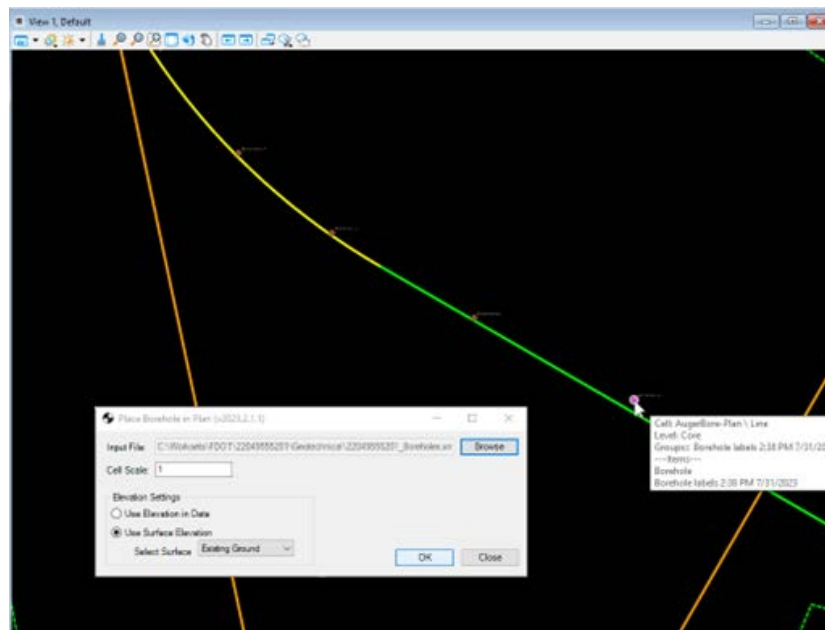

NOTE The *Use Elevation in Data* option will use the supplied data or 0 if blank.

3. Make the *Default-3D* view active. On the *FDOT* tab, select **Place Boreholes In 3D Model** from the *Geotech Tools* drop-down under the *Geotechnical* group. Select the **Use Surface Elevation** option and **Existing Ground** from the drop-down. Leave all other values as default and click the *Browse* button to select the file *2049555201_Boreholes.xml* from the project *Geotechnical* folder and click **Open**. Click **OK** to plot the boreholes in the 3D model.

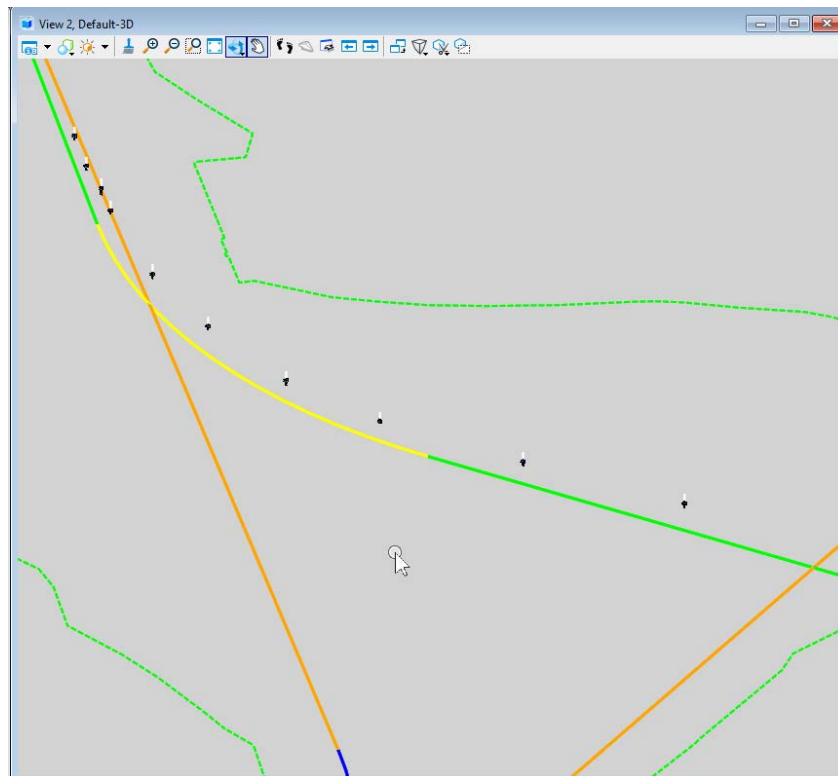
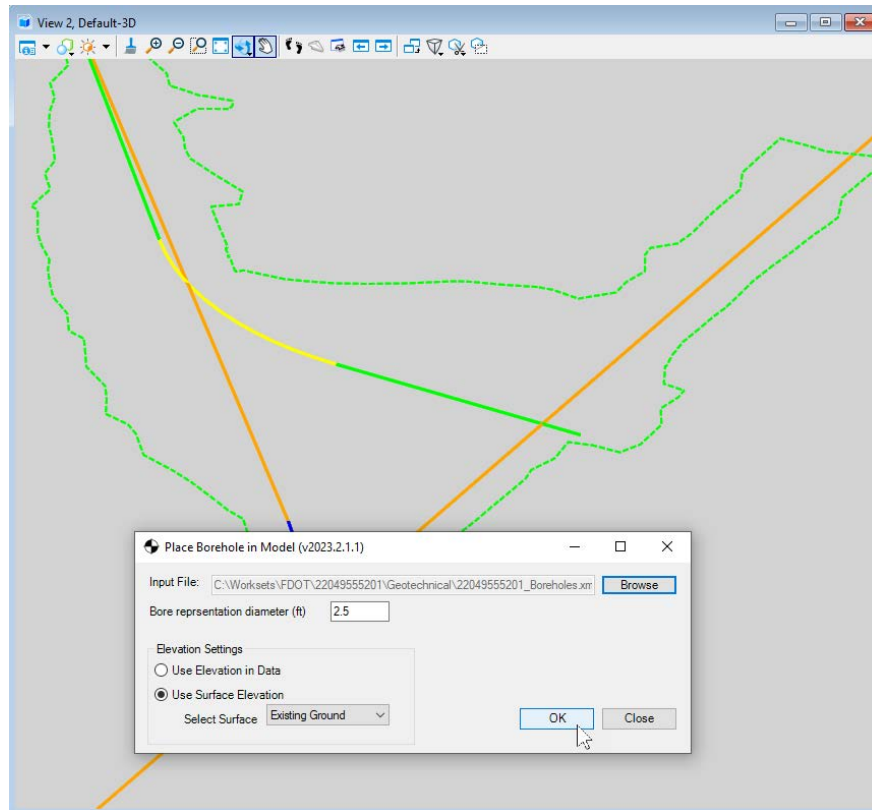

4. Zoom into the view to examine the different layers of each borehole.

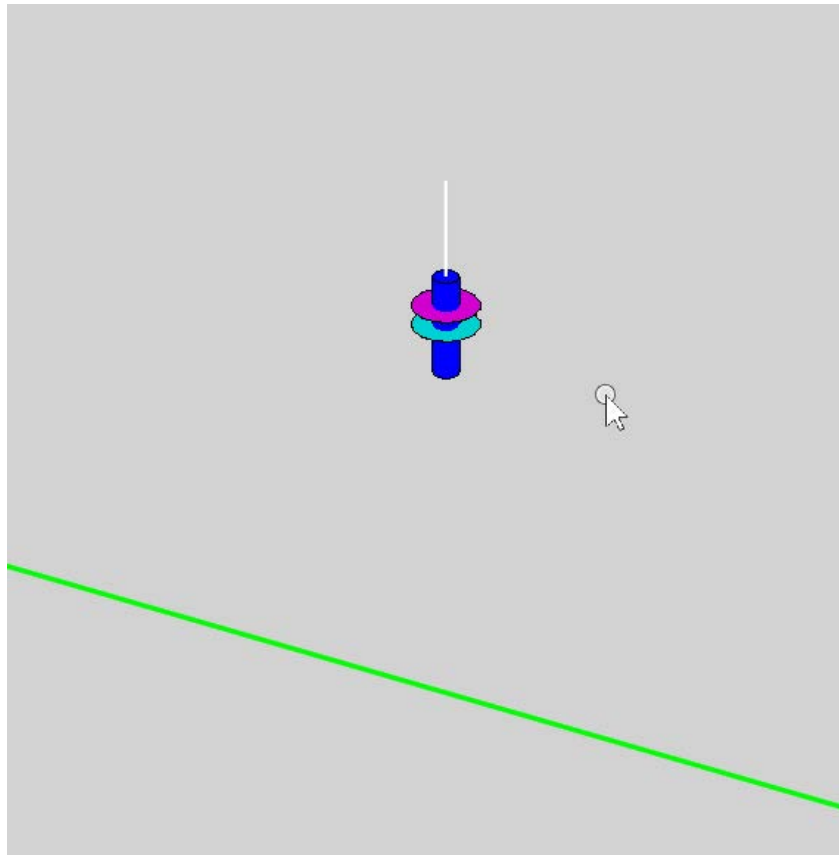

Select one of the Borehole pins to view the properties

Properties

Elements (1)

- Line
 - Items

General

Element Description	Line
Level	Geotech_Misc_em
Color	ByLevel (0)
Line Style	ByLevel (0)
Weight	ByLevel (1)
Class	Primary
Template	(None)
Transparency	0

Geometry

Extended

Model	Default-3D
Last Modified	9/11/2023 3:33:15 PM
Snappable	Snappable
Modified	Modified
New	New
Locked	Unlocked
Thickness	0.0000'
Line Style Parameters	
Display Style	(From View Display)

BoreHole

BoreholeID	Borehole-01
Type	Auger
Depth	10.0000
Reference	SR61_CL
Station	702+00.00
Offset	15
Northing	402755.582908974
Easting	2006667.72470713
CoordinateSystem	FL83/2011-NF
Latitude	30.1074154986339°

Exercise 6.5 Create an Event Points List in the ALGNRD file

1. Open the file *ALGNRD01.dgn* from the project *Roadway* folder.
2. Key **F9** to open the *References* dialog. **Attach** the file *ABORRD01.dgn* from the project *Geotechnical* folder.
3. Create a *Selection Set* of the elements on the **Core** level. From the *Geometry* tab, select **Event Point List** in the *Common Tools* group.

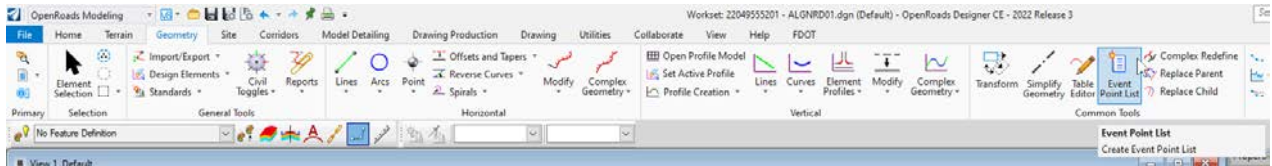

4. Follow the *cursor prompt* to locate the alignment **SR61_CL**. Choose **No** for the cardinal points options. The *Event Point List* dialog will appear. Click the first option **Add List**. Name the list **Boreholes SR61_CL** and click **OK**.

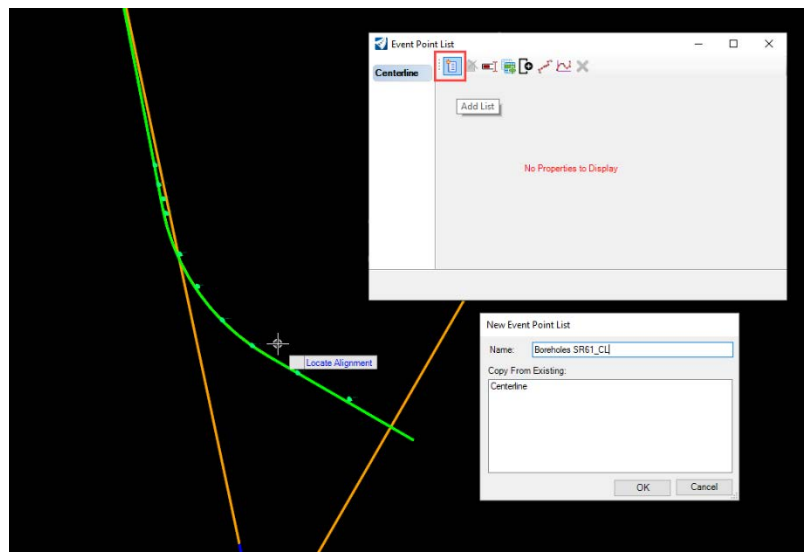

5. Select the *Boreholes SR61_CL* list and click the option **Add By Northing Easting**. Reset in the view, then data point to accept. The *Event Point List* is populated with the borehole location data and automatically saved. **Close** the tool.

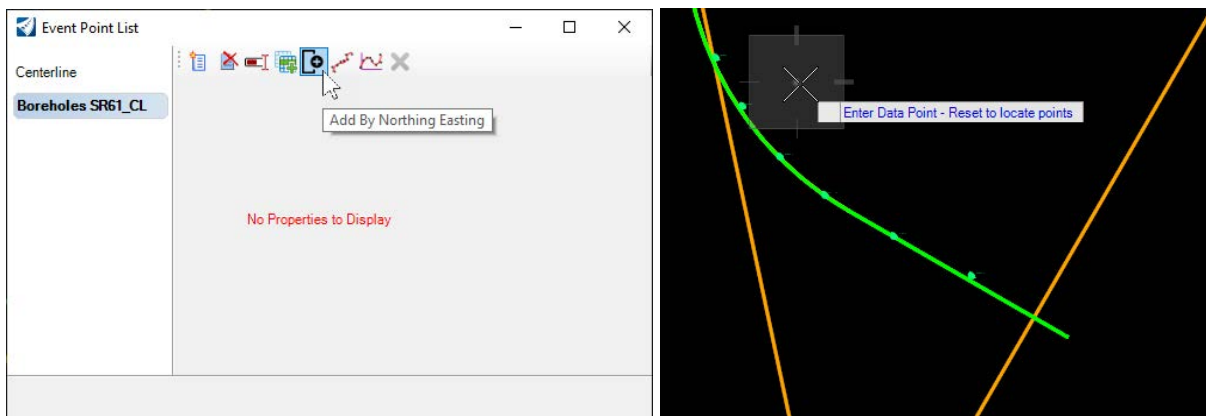

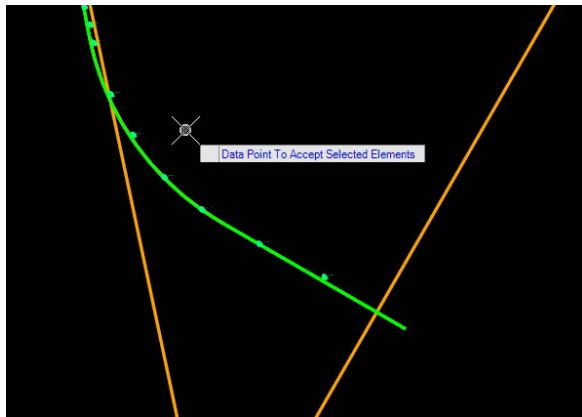

Event Point List

Centerline

Boreholes SR61_CL

Method	Station	Offset	Northing	Easting	Description
▶ Northing...	701+9...	20.47	402759...	2006671...	
Northing...	702+0...	15.00	402755...	2006667...	
Northing...	704+3...	8.47	402865...	2006464...	
Northing...	704+3...	3.00	402861...	2006460...	
Northing...	706+4...	8.56	402974...	2006281...	
Northing...	706+4...	3.00	402970...	2006277...	
Northing...	708+0...	4.00	403073...	2006157...	
Northing...	708+0...	9.63	403077...	2006161...	
Northing...	709+7...	12.00	403208...	2006056...	

Exercise 6.6 Create a RDXSRD file to show Borehole information in Cross Sections

1. Launch the **Create File** tool from the *FDOT* tab of the ribbon in the *Actions* group. Switch the *Discipline* to **Roadway** and the *File Group* to **Roadway Sheet Files**. Select the *Base Filename* **RDXSRD** from the list. Select a **Coordinate System** for the file or select a **County** which automatically populates the coordinate system dropdown. Make sure all settings match the dialog below, and then click **Create - Open File**. Close the **Create File** tool.

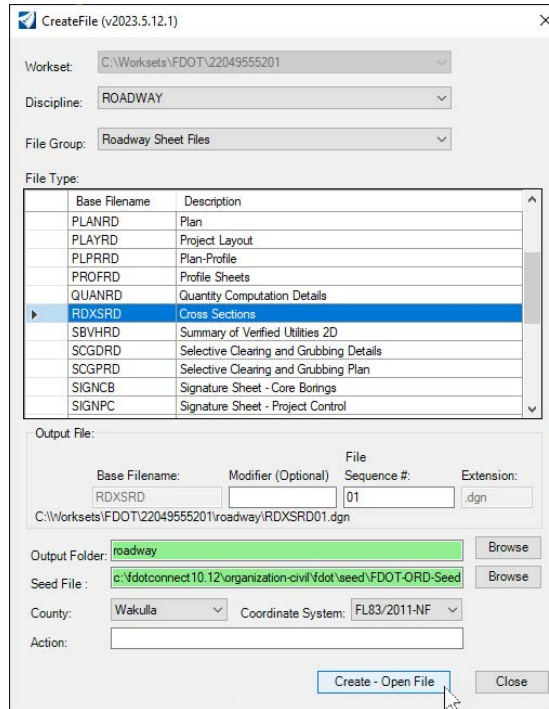

2. Key **F9** to open the *References* dialog and **Attach** the following files:
 C:\WorkSets\FDOT\22049555201\Roadway\ALGNRD01.dgn
 C:\WorkSets\FDOT\22049555201\Roadway\MODLRD_Detail61.dgn
 C:\WorkSets\FDOT\22049555201\Roadway\MODLRD_Mainline61.dgn
 C:\WorkSets\FDOT\22049555201\Geotechnical\ABORRD01.dgn
 C:\WorkSets\FDOT\22049555201\Survey\GDTMRD01.dgn
3. Set the *Existing Ground* terrain model as **Active**. Key **F2** to open the *Default & Default-3D* views
4. On the *Drawing Production* tab, select **Place Named Boundary** under the *Named Boundary* drop-down in the *Named Boundaries* group.

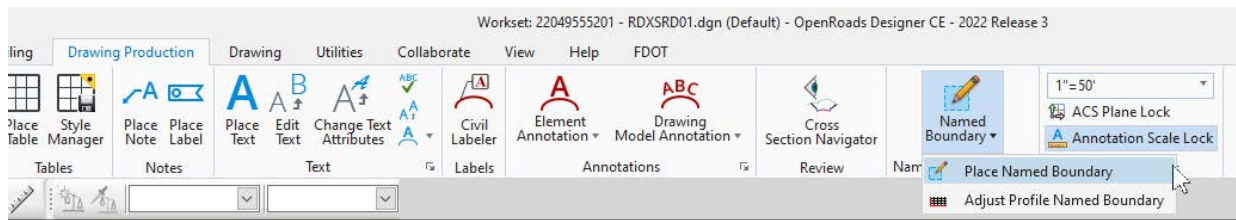

5. Select the *Civil Cross Section* mode and set the *Drawing Seed* to **11x17 Cross Sections**. In the *Default* view, select the **SR61_CL** alignment. In the *Event Point List* drop-down, select the list **Boreholes SR61_CL**. Tick the box **Include Event Points Only** and **Create Drawing**. Accept the *cursor prompts* to place the named boundaries.

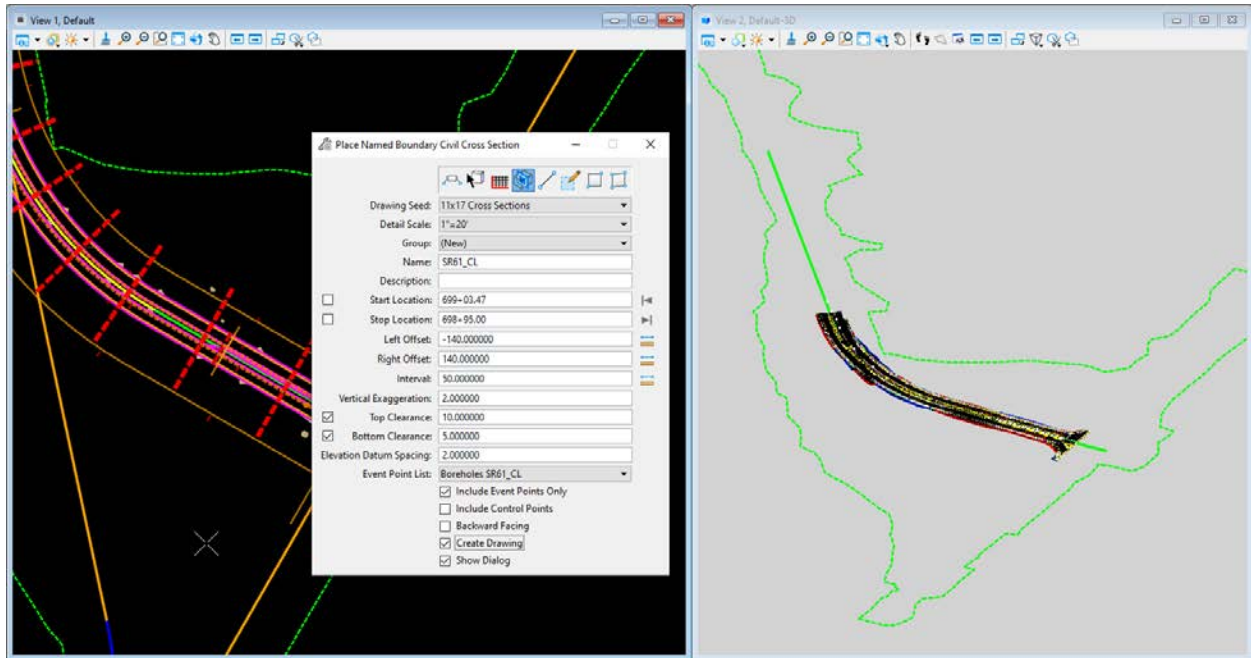

6. Leave the default options on the *Create Drawing* dialog and click **OK** to create the sheets. The sheets will process and drop into the last sheet model. Verify borehole data on the cross sections.

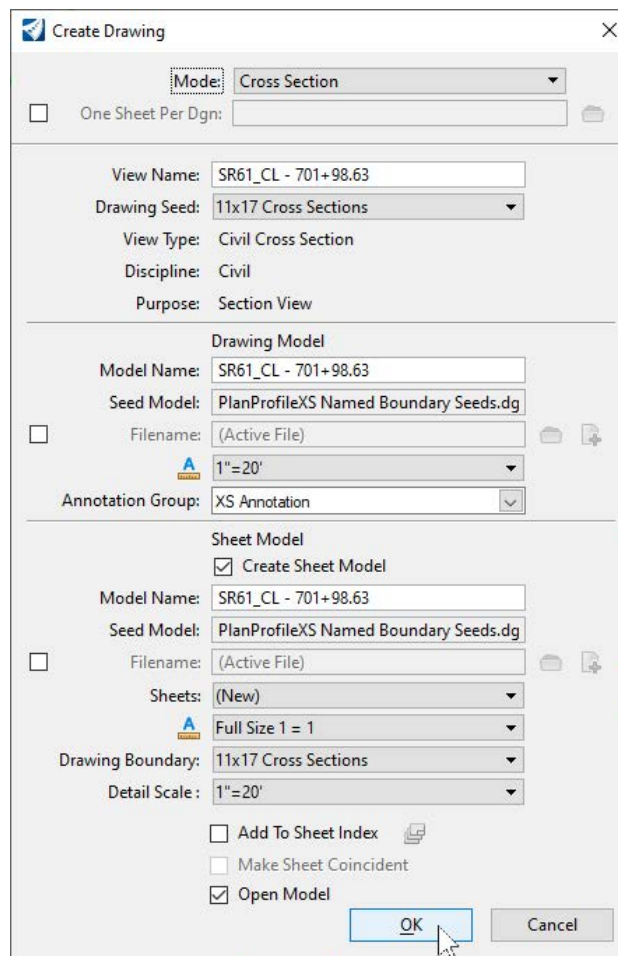

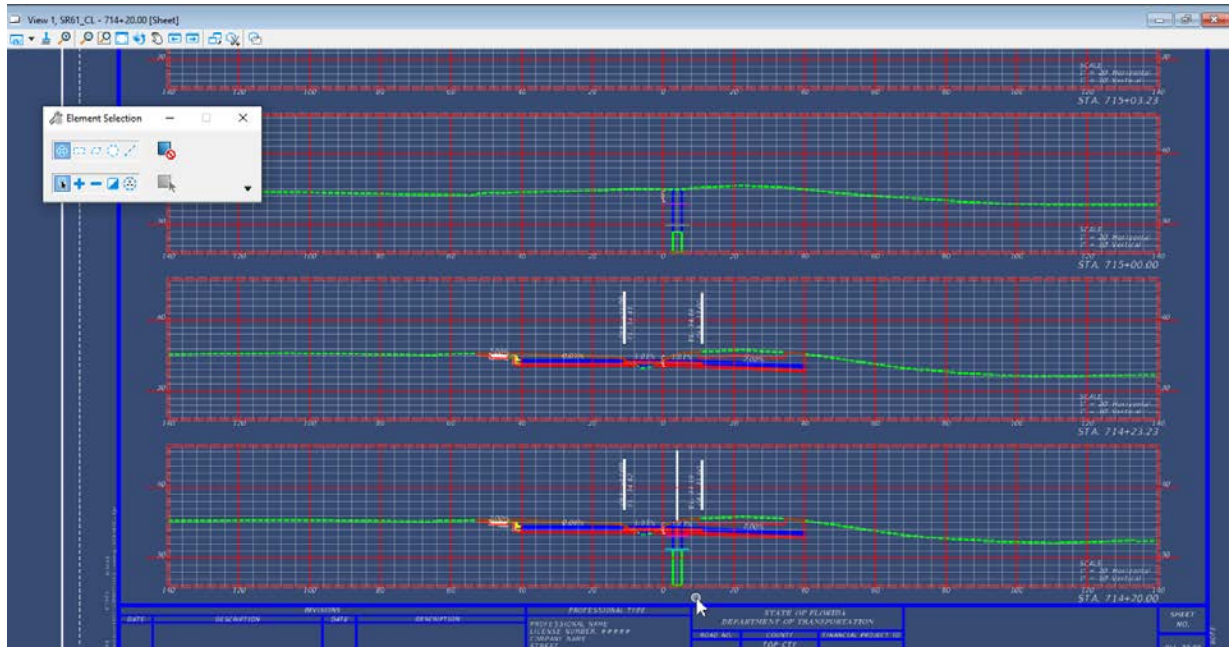

- On the *FDOT* tab of the ribbon, open the **Geotech XSection Labeler** from the *Geotech Tools* drop-down of the *Geotechnical* group. The tool scans the file for drawing models to label. Click **Process** to complete.

DXSRD01.dgn (SR61_CL - 714+20.00 [Sheet]) - OpenRoads Designer CE - 2022 Release 3

Help | FDOT

Signal Design | Light Pole Manager | Geotech Data Manager | **Geotech Tools** | Takeoff Manager | QC Quick | QC Project | QC STOP

Geotechnical Plans

- Place Boreholes In 2D Plan
- Place Boreholes In 3D Model
- Adjust Geotech Named Boundaries
- Geotech XSection Labeler**
- Report of Core Borings

Drawing Models to Process

Drawing Model Names

- SR61_CL - 701+98.63
- SR61_CL - 702+00.00
- SR61_CL - 704+30.63
- SR61_CL - 704+32.00
- SR61_CL - 706+45.10
- SR61_CL - 706+46.00
- SR61_CL - 708+05.00
- SR61_CL - 708+05.12
- SR61_CL - 709+75.00
- SR61_CL - 709+76.22
- SR61_CL - 711+25.00
- SR61_CL - 711+27.16
- SR61_CL - 713+00.00
- SR61_CL - 713+03.16
- SR61_CL - 713+60.00
- SR61_CL - 713+63.23
- SR61_CL - 714+20.00
- SR61_CL - 714+23.23

Select All | Select None | **Process** | Cancel

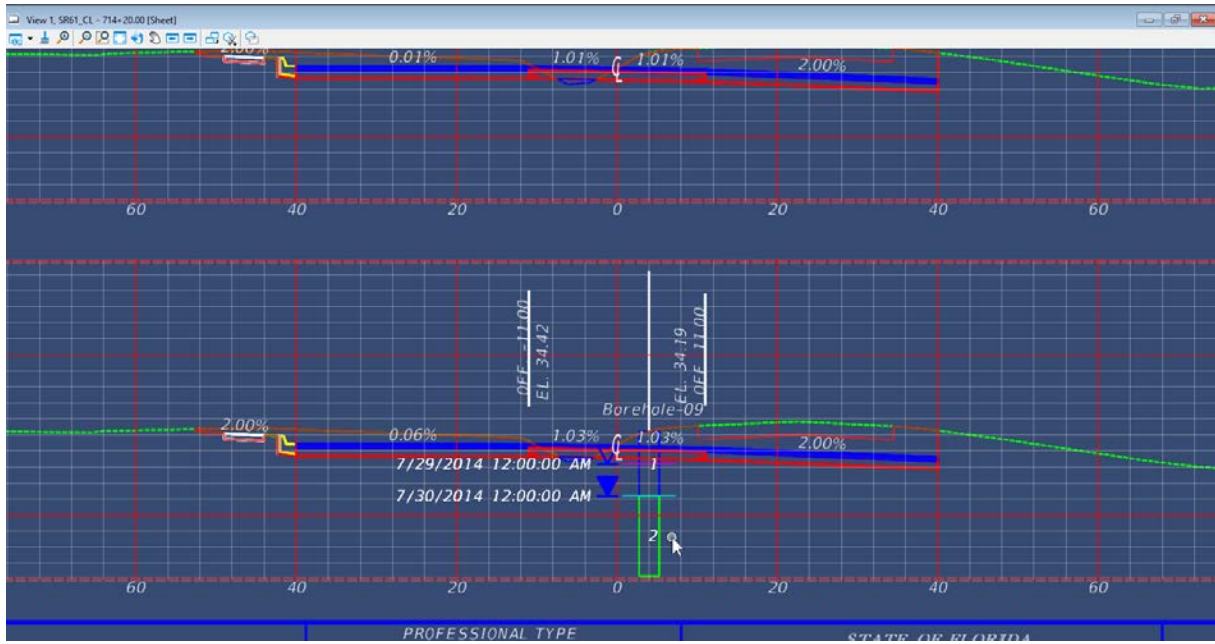

Exercise 6.7 Use the Report of Borings tool to create the Report of Core Borings Sheet

1. Launch the **Create File** tool from the *FDOT* tab of the ribbon in the *Actions* group. Switch the *Discipline* to **Roadway** and the *File Group* to **Geotechnical Sheet Files**. Select the *Base Filename* **RPTBRD** from the list. Select a **Coordinate System** for the file or select a **County** which automatically populates the coordinate system dropdown. Make sure all settings match the dialog below, and then click **Create - Open File**. Close the **Create File** tool.

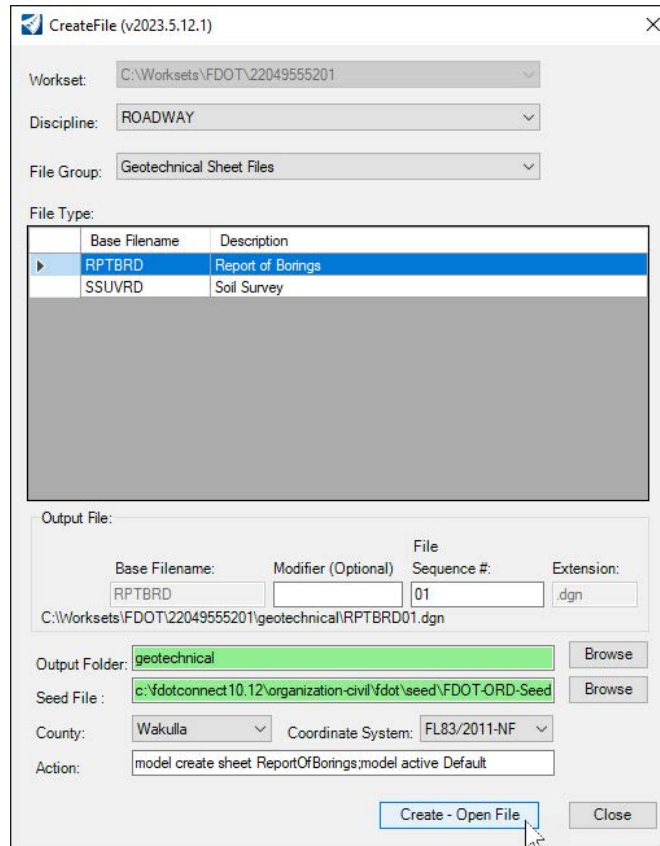

2. On the *FDOT* tab of the ribbon, launch the **ReportofCoreBorings** tool from the *Geotech Tools* drop-down in the *Geotechnical* group. Select the *Browse* button and navigate to the file **22049555201_Boreholes.xml** in the *Geotechnical* folder. Select the *Roadway (soil stratum number)* option and click **Create Report**.

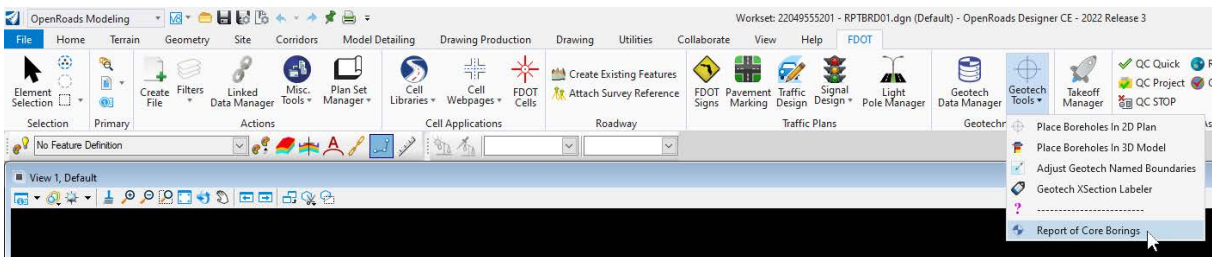

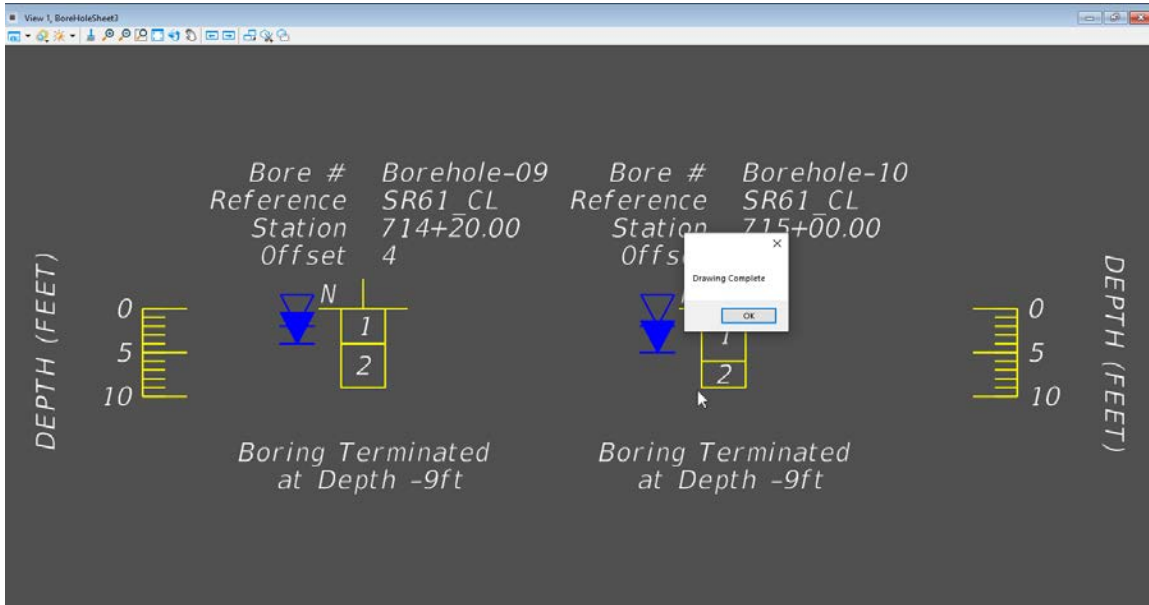
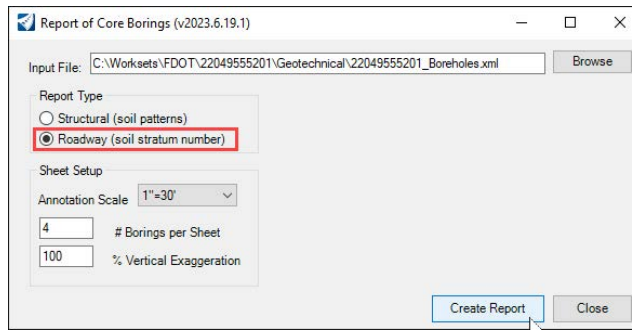

NOTE The Vertical Exaggeration value can be increased past 100% if the strata numbers aren't fitting correctly.

- On the *Home* tab, launch the **Models** dialog from the *Primary* group. Open the model **ReportOfBorings**.



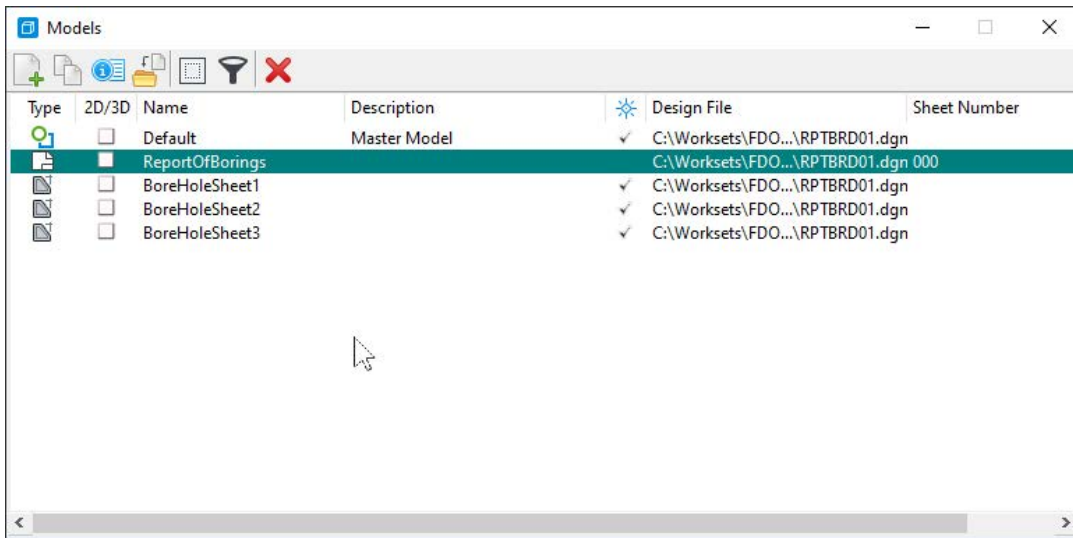

4. Key **F9** to open the *References* dialog and **Attach** the file *RPTBRD01.dgn*. Select the model **BoreHoleSheet1** in the drop-down list and click **OK**. Right-click the attachment and select the **Move** option to position the reference on the sheet.

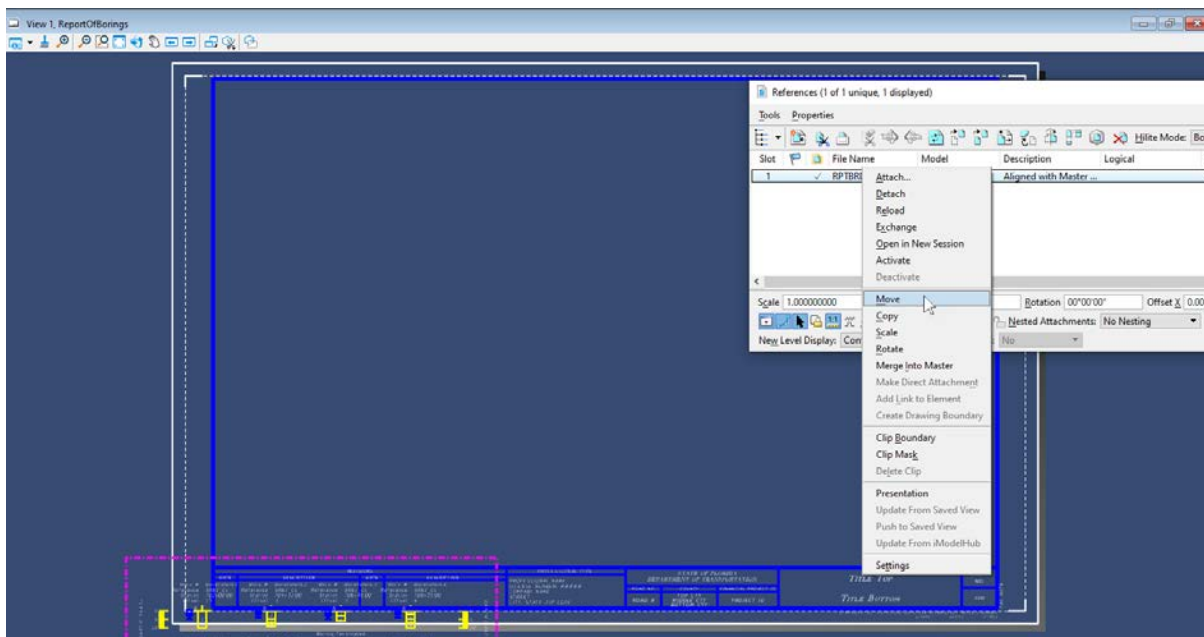

- Repeat step 4 with each **BoreHoleSheet** reference to populate the sheet. Edit the sheet title and other information as necessary.

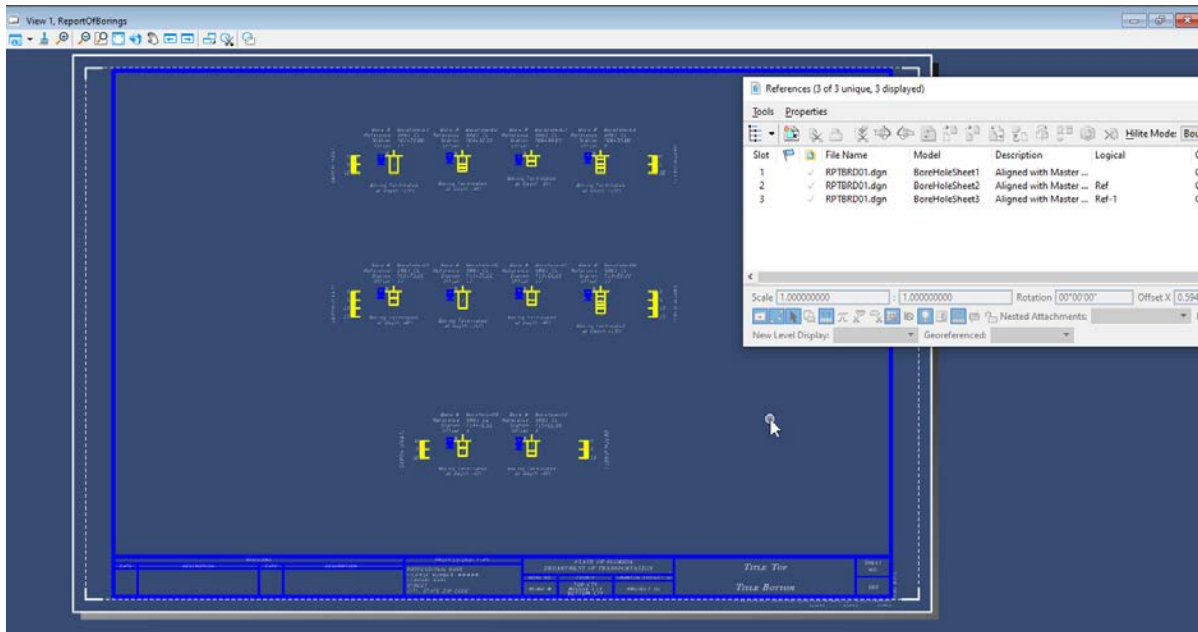

Exercise 6.8 Create a Soil Survey Sheet for plans

1. Launch the **Create File** tool from the *FDOT* tab of the ribbon in the *Actions* group. Switch the *Discipline* to **Roadway** and the *File Group* to **Geotechnical Sheet Files**. Select the *Base Filename* **SSUVRD** from the list. Select a **Coordinate System** for the file or select a **County** which automatically populates the coordinate system dropdown. Make sure all settings match the dialog below, and then click **Create - Open File**. Close the **Create File** tool.

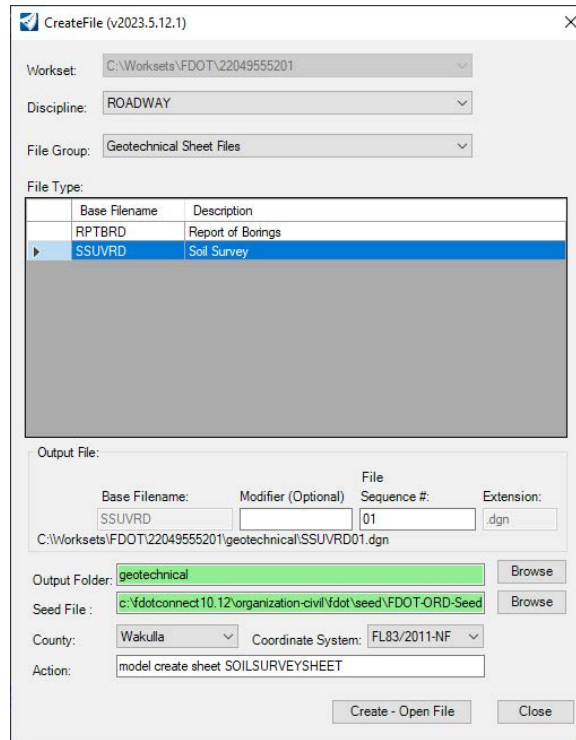

2. On the *FDOT* tab of the ribbon, select the **Linked Data Manager** tool in the *Actions* group. Click the first option **Create new link**, then click **Create New from Template**. In the drop-down, select **Sheets** and choose **Roadway Soil Survey**, then click **OK**.

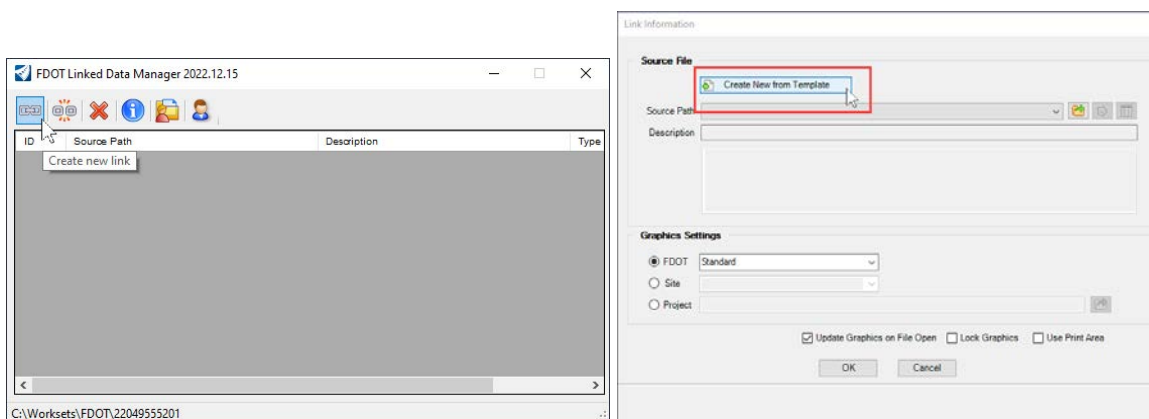

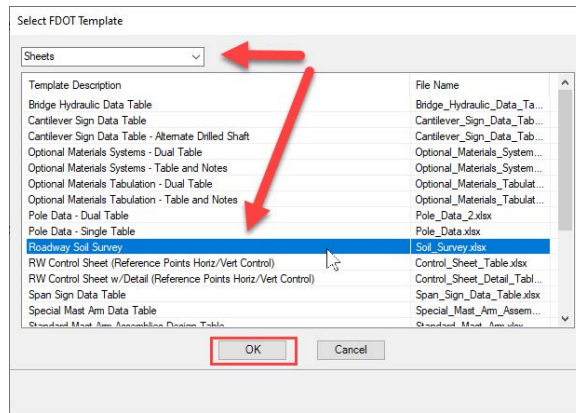

3. Save the file as **22049555201_Soil_Survey.xlsx** in the project *Roadway>eng_data* folder. On the *Worksheet* drop-down select **Sheet1** and click **OK**. Position the cell on the sheet and **Data Point** to accept the placement.

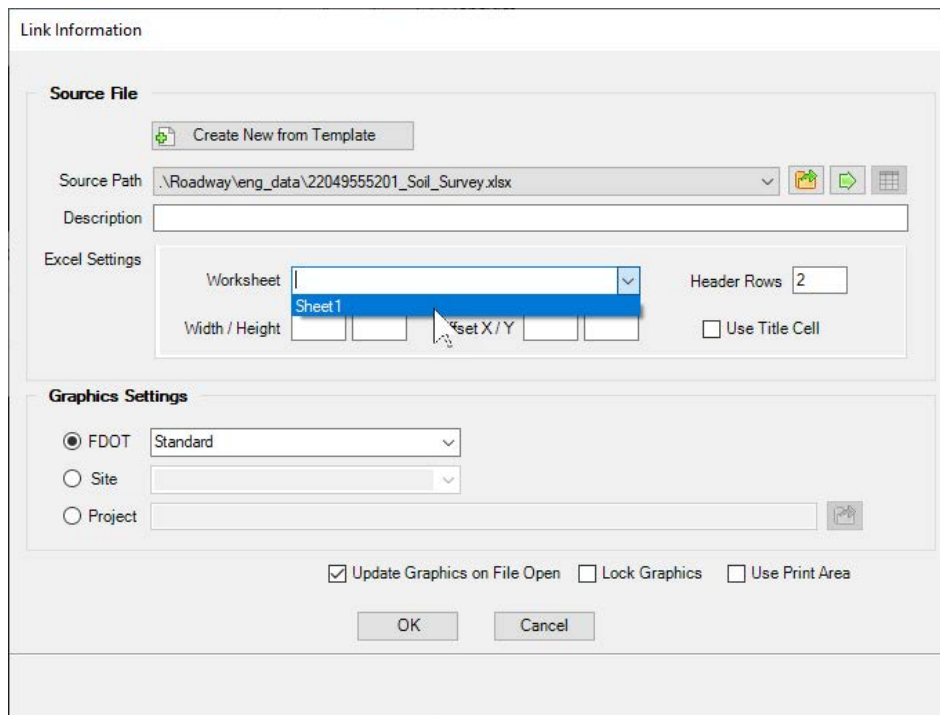
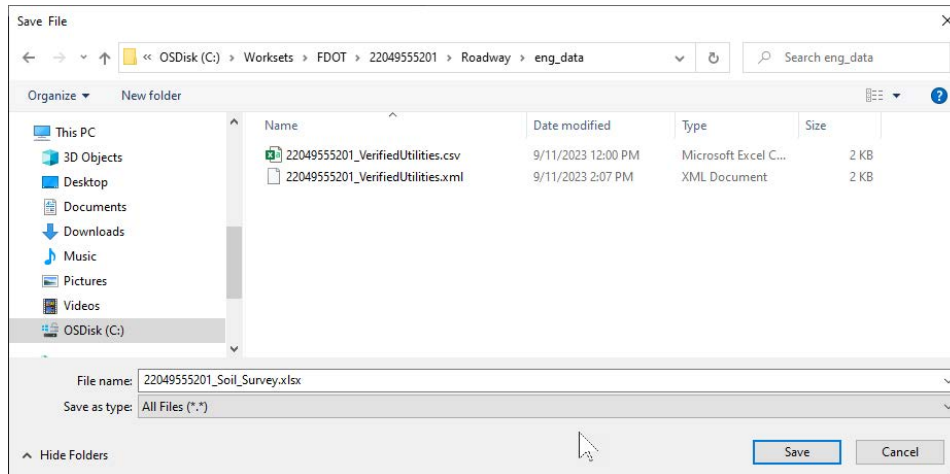

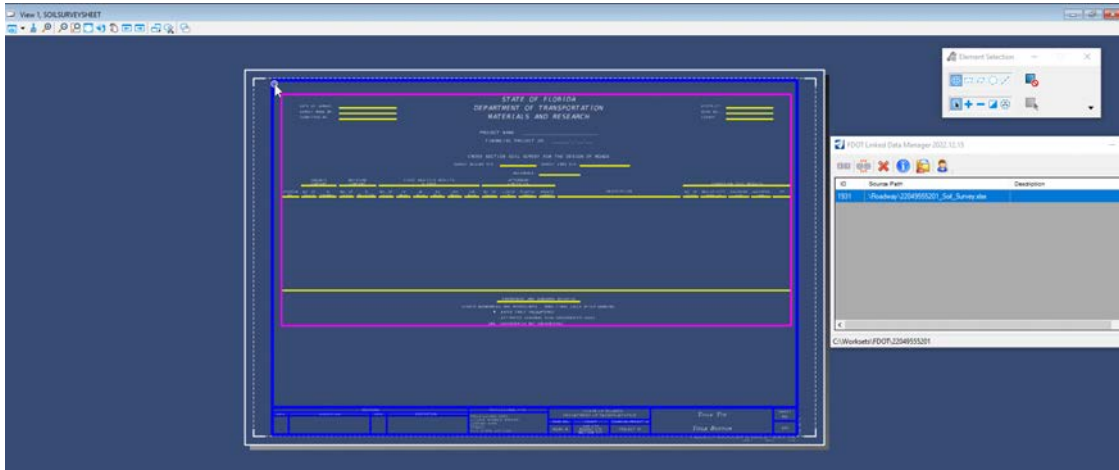

4. Modify the source Excel workbook by *right clicking* the entry in the **Linked Data Manager** dialog and selecting the option **Open Source**.

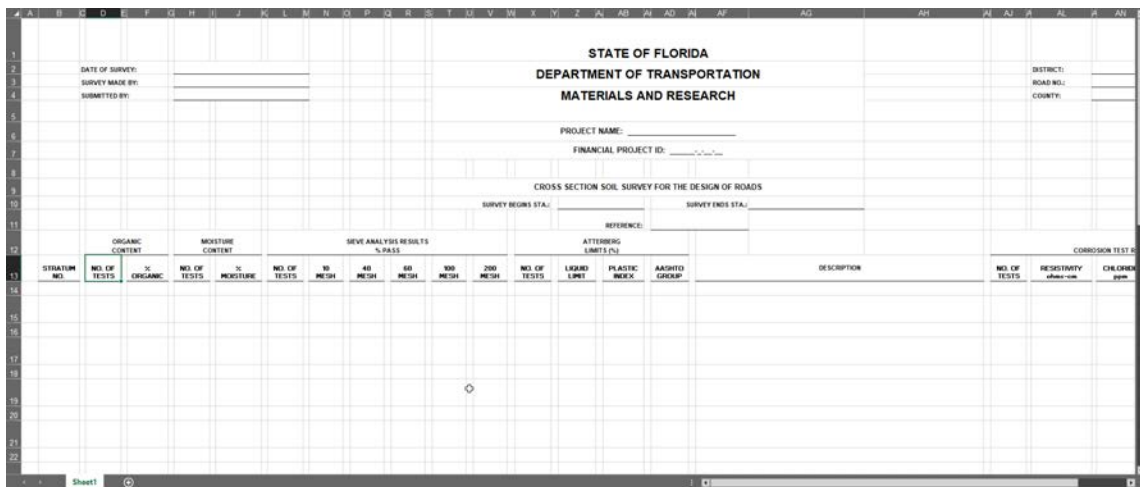
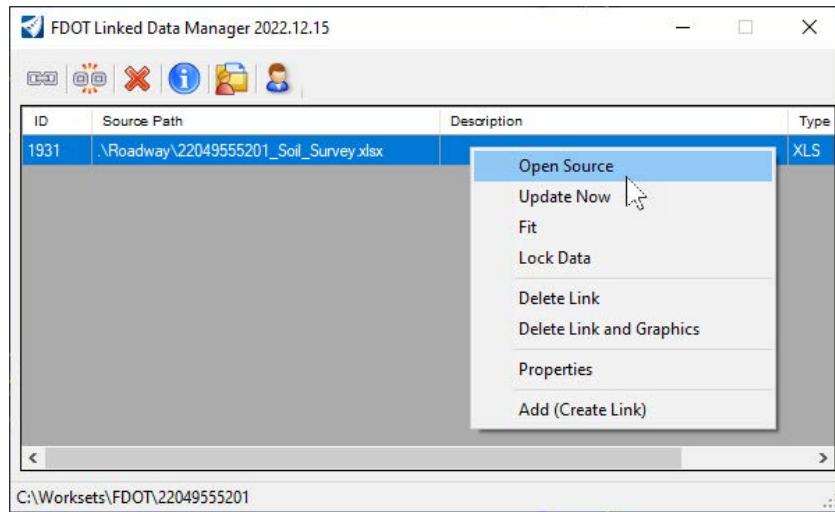

Contact

www.fdot.gov/cadd

Address

605 Suwannee St
Tallahassee, FL. 32399

Existing Features 3D Modeling