

*State of Florida
Department of Transportation*



FDOT Civil 3D Roadway Design & 3D Modeling - Basic

User Training Guide

April,7,2021

PRODUCTION SUPPORT CADD OFFICE

TALLAHASSEE, FLORIDA

<http://www.fdot.gov/cadd/>

FDOT Civil 3D Roadway Design & 3D Modeling

Basic

Description

This 2-day course provides participants with advanced training on Civil 3D design workflow of creating a Corridor with the FDOT Subassemblies within depth focus on Regions and Targeting using the latest FDOT CADD Software suite release.

This course will demonstrate the workflows for base map compilation, displaying and editing roadway features in plan and profile views, and creating finished ground terrain models. Roadway alignments, profile views, and digital terrain models are utilized to display and edit the roadway parts during the design process.

This course includes examples of intersection design, corridor modeling, traffic separator design, traffic island design , along with 3D visualization tools to enable the user to quickly recognize errors and confirm satisfaction of design intent.

Objectives

The student will have a basic understanding of

- FDOT Civil 3D State Kit Tools
- Corridor Creation
- Alignments and Profiles
- Surfaces
- Annotation
- Data Management Techniques Annotating Plans

Audience

This course is intended for roadway designers.

Prerequisites

Participants need to have a (basic) understanding of AutoCAD and AutoCAD Civil 3D.

Duration: 16 Hours

Professional Credit Hours: 16 PDHs

Note PDH Credit will only be available with Instructor lead or Computer Based Training (CBT) thru Learning Curve.

Contents

1	GETTING STARTED.....	1-1
	DESCRIPTION	1-1
	OBJECTIVES	1-1
	PREREQUISITES.....	1-1
	INTRODUCTION	1-1
	<i>Purpose</i>	1-1
	<i>Terminology</i>	1-1
	<i>Civil 3D Objects Used In The Datasets For This Manual</i>	1-2
	<i>About Civil 3D</i>	1-2
	<i>Civil 3D Drawings</i>	1-2
	<i>Resources</i>	1-2
2	WHAT IS A CORRIDOR?	2-1
	DESCRIPTION	2-1
	CHAPTER SETUP	2-1
	CORRIDOR MODELING OVERVIEW	2-1
	WHAT IS A CORRIDOR?.....	2-5
	<i>What are the components of a Corridor?</i>	2-5
	WHAT IS AN ASSEMBLY?	2-7
	<i>Creating an Assembly</i>	2-9
	WHAT ARE SUBASSEMBLIES?	2-10
	<i>Adding Subassemblies to an Assembly marker</i>	2-11
	WHAT ARE THE ELEMENTS OF A SUBASSEMBLY?	2-13
	<i>Points:</i>	2-13
	<i>Link:</i>	2-13
	<i>Shape:</i>	2-14
	TYPICAL SECTION DETAIL:.....	2-14
	CORRIDOR FEATURE LINES.....	2-15
	SPECIAL PURPOSE CORRIDORS FOR C3D	2-15
	TYPICAL WORKFLOWS	2-16
	<i>Workflow: To Create Corridors</i>	2-16
	<i>Workflow: To Edit a Corridor in Section View</i>	2-16
	<i>Workflow: To Visualize Corridors</i>	2-16
	<i>Workflow: To Export Corridor Data</i>	2-16
3	BASIC CIVIL 3D FUNCTIONS	3-1
	DESCRIPTION	3-1
	OBJECTIVES	3-1
	CHAPTER SETUP	3-1
	CIVIL 3D TOOLSPACE.....	3-2
	<i>Toolspace Prospector Tab</i>	3-2
	<i>Toolspace Settings Tab</i>	3-4
	Object Style Collection (Settings Tab).....	3-7
	Label Styles Collections (Settings Tab).....	3-8
	Table Styles Collections (Settings Tab)	3-9
	Commands Collections (Settings Tab)	3-10
	General Collection (Settings Tab)	3-11
	WORKING WITH WORKSPACES	3-12
	CIVIL 3D RIBBON.....	3-13
	<i>Static Ribbon Tabs</i>	3-13
	<i>Contextual Ribbon Tabs</i>	3-13
	FDOT TAB	3-14
	AUTOCAD CIVIL 3D MENUS	3-15
	<i>Application Menu</i>	3-15

Context Menus.....	3-16
PANORAMA WINDOW.....	3-17
<i>Displaying the Panorama Window</i>	3-18
<i>Features of the Toolspace and Panorama Windows</i>	3-18
LAYOUT TOOLBARS	3-19
4 CREATING THE GTDMRD01 FILE	4-1
DESCRIPTION	4-1
OBJECTIVES	4-1
CHAPTER SETUP	4-1
Exercise 4.1 Set Data Shortcuts Paths	4-2
Exercise 4.2 Create a Digital Terrain Model - Tin Model - 3D file GDTMRD01 File.....	4-5
Exercise 4.3 Associate Project to Current Drawing.....	4-6
Exercise 4.4 Import LandXML File.....	4-7
Exercise 4.5 Insert block Surface Boundary.dwg	4-10
Exercise 4.6 Use Boundary Line work to create Surface Boundary:	4-13
Exercise 4.7 View Geolocation Maps for correct location:	4-15
Exercise 4.8 Create Surface Date Shortcuts:.....	4-18
5 CREATING THE ALGNRD01 FILE.....	5-1
DESCRIPTION	5-1
OBJECTIVES	5-1
CHAPTER SETUP	5-1
Exercise 5.1 Set Data Shortcuts Paths	5-2
Exercise 5.2 TOGGLE SELECTION CYCLING ON:	5-4
Exercise 5.3 Open the ALGNRD01.DWG	5-5
Exercise 5.4 Associate Project to Current Drawing.....	5-8
Exercise 5.5 Import Alignment from ALGNRD-SR61 LandXML file.....	5-9
Exercise 5.6 Add Alignments to Data Shortcuts.....	5-14
6 CREATING THE MODLRD01-EXISTING CONDITIONS CORRIDOR	6-1
DESCRIPTION	6-1
OBJECTIVES	6-1
CHAPTER SETUP	6-1
OVERVIEW OF THE FDOT EXISTING FEATURES ASSEMBLY.....	6-2
<i>FDOT Existing Features Assembly</i>	6-3
Attachment.....	6-3
Input Parameters.....	6-3
Target Parameters	6-5
Output Parameters	6-6
Behavior.....	6-6
Assumptions:	6-6
Pavement:.....	6-6
Traffic separators:.....	6-6
Shoulder:	6-6
Guardrail:.....	6-6
Back of curb:	6-7
Sidewalk:.....	6-7
Layout Mode Operation	6-7
Point, Link, and Shape Codes.....	6-7
Coding Diagram	6-7
Exercise 6.1 Set Data Shortcuts Paths	6-8
Exercise 6.2 TOGGLE SELECTION CYCLING ON:	6-10
Exercise 6.3 Create MODLRD01-Existing Conditions file	6-11
Exercise 6.4 Associate Project to Current Drawing.....	6-12
Exercise 6.5 Attach External Reference file TOPORD01.dwg.....	6-13
Exercise 6.6 Create Data Shortcut Reference for DTM Existing Surface.....	6-15

Exercise 6.7	Create Data Shortcut Reference for EX-SR61, SR61 and US98 Alignments	6-17
Exercise 6.8	Create Existing Surface Profile for SR61 Centerline Alignment	6-20
Exercise 6.9	Create Existing Condition Assembly	6-25
Exercise 6.10	Create SR61 - Existing Conditions Corridor.....	6-29
Exercise 6.11	Create Sample Lines for SR61 Centerline Alignment.....	6-34
Exercise 6.12	Create Cross Sections Views for the SR61 Centerline Alignment	6-37
7	CREATE CORRIDOR MODEL	7-1
	DESCRIPTION	7-1
	OBJECTIVES	7-1
	CHAPTER SETUP	7-1
	Exercise 7.1 Create MODLRD02.dwg.....	7-2
	Exercise 7.2 Create offset alignments and offset profiles	7-2
	Exercise 7.3 Creating a Corridor Model - First Pass – Through Lane	7-11
	Exercise 7.4 Corridor Model – Second Pass – Curb, Sidewalk, and EOP Target.....	7-21
	Exercise 7.5 Creating a Corridor Model – Third Pass – Median and Left Turn Lane	7-29
8	CORRIDOR SURFACE.....	8-1
	DESCRIPTION	8-1
	OBJECTIVES	8-1
	CHAPTER SETUP	8-1
	Exercise 8.1 Create MODLRD03.dwg.....	8-2
	Exercise 8.2 Corridor Model Properties.....	8-2
	Exercise 8.3 3D Display Techniques.....	8-7
9	CREATE SR61-LEFT CORRIDOR	9-1
	DESCRIPTION	9-1
	OBJECTIVES	9-1
	CHAPTER SETUP	9-1
	Exercise 9.1 Create MODLRD02.dwg.....	9-2
	Exercise 9.2 Create SR61-Left Assembly.....	9-2
	Exercise 9.3 Create Corridor Model SR61-Left	9-6
10	CREATE SR61 FINAL SURFACE	10-13
	DESCRIPTION	10-13
	OBJECTIVES	10-13
	CHAPTER SETUP	10-13
	Exercise 10.1 Create MODLRD02.dwg.....	10-14
	Exercise 10.2 Create SR61-Left Corridor Surface.....	10-14
	Exercise 10.3 Create a SR61 Final Surface	10-16

1 GETTING STARTED

DESCRIPTION

This chapter provides the background information and context to help the user prepare to use this manual.

OBJECTIVES

This chapter is divided into two sections:

- Introduction
 - Purpose
 - Terminology
 - Civil 3D Objects
 - About Civil 3D
 - About this Manual
 - Resources
- Project Components
 - Civil 3D Drawings

PREREQUISITES

Basic understanding of AutoCAD and AutoCAD Civil 3D.

INTRODUCTION

PURPOSE

This manual serves two primary functions. It is a training manual for instructor-led training, and a user's manual for roadway engineers, designers, and technicians. Lab exercises are provided at the end of the chapters, although the instructor-based classes may not use all the exercises or cover all the chapters.

TERMINOLOGY

Throughout this document the term “Department” refers to the Florida Department of Transportation. The Department’s standards for roadway design are provided in the Roadway Manual. Guidelines for roadway design are provided in the various roadway handbooks The Department’s Plans Preparation Manual and CADD Manual provide the standards for preparing the construction plan sets. Discussions about how to best use Civil 3D to comply with the Department’s CADD standards and guidelines are included in this document where appropriate.

CIVIL 3D OBJECTS USED IN THE DATASETS FOR THIS MANUAL

- Surface
- Feature Line
- Alignment
- Profile
- Profile View
- Assembly
- Sub-Assemblies
- Corridor
- Section Views

Note Descriptions for each object can be found in the Civil 3D Online Help system:

<https://knowledge.autodesk.com/support/autocad-civil-3d>

ABOUT CIVIL 3D

Civil 3D is a comprehensive application for designing a roadway design. Civil 3D includes a comprehensive set of tools for designing roadways in a dimensionally accurate 3D model. The FDOT Civil 3D State Kit contains custom assemblies and sub-assemblies used for roadway design.

The assemblies and sub-assemblies objects can be edited graphically or numerically using a variety of convenient user interface features including interactive dialog boxes, cursor menus, tool tips, toolbars, ribbons, palettes, with most of these having context sensitive behaviors. Predefined styles compliant with FDOT standards are included with the FDOT Civil 3D State Kit. These styles control the graphical appearance of the assemblies and sub-assemblies, their labels and much more.

Preset command behaviors simplify the use of commands so Civil 3D objects such as assemblies and sub-assemblies are created and labeled simultaneously using the desired styles. Designs are produced with less effort and eliminate labeling errors.

CIVIL 3D DRAWINGS

Civil 3D Drawing Files are in a binary format with a .dwg file extension. They contain object tables and databases. When opened in an AutoCAD environment the drawing displays graphical and textual content. Civil 3D objects are created and stored in this dwg file format along with native AutoCAD objects.

RESOURCES

- Roadway Design
<http://www.fdot.gov/roadway/Drainage/Manualsandhandbooks.shtm>
- CADD Manual
<http://www.fdot.gov/cadd/downloads/publications/publications.shtm>
- FDOT Civil 3D State Kit
<http://www.fdot.gov/cadd/downloads/software/software.shtm>

2 What is a Corridor?

DESCRIPTION

This chapter introduces you to Corridor Modeling using AutoCAD Civil 3D and the FDOT Civil 3D State Kit.

In this chapter, you will learn about:

- Corridors
- Assembly
- Sub Assemblies
- Surfaces
- Feature Lines
- Alignments
- Profiles

CHAPTER SETUP

There are no chapter datasets to restore for this chapter.

Note Some of the content in this chapter is from the Civil 3D 2018 Help file and has been edited to follow the FDOT workflows.

CORRIDOR MODELING OVERVIEW

You can use AutoCAD Civil 3D corridor modeling to create 3D models of corridors, such as roads, highways, Intersections, and Roundabouts.

A corridor model builds on and uses AutoCAD Civil 3D objects and data, including subassemblies, assemblies, surfaces, feature lines, alignments, and profiles. The corridor manages the data, tying various assemblies (applied for different ranges of stations) to the baselines and their finished grade profiles.

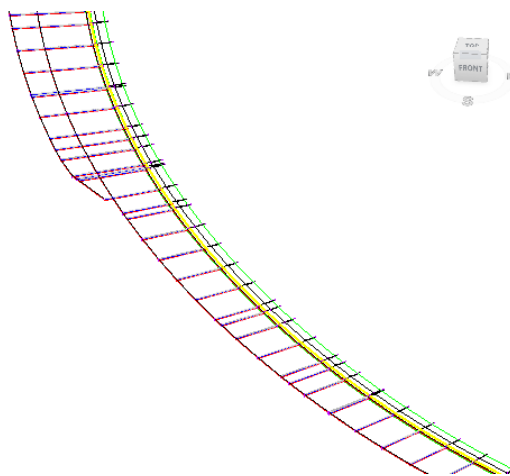

Corridors exist in a drawing as Objects. Corridor objects include corridor body geometry, longitudinal feature lines, embedded surfaces, rendering support, and slope hatching support.

A corridor can define and display components, such as:

- Feature lines connecting points along the point codes, which are defined in the subassemblies (used to create the assemblies).
- Surfaces, using link codes and feature lines.

A corridor object is created from a baseline (alignment or feature line) by placing 2D sections (assemblies) at incremental locations, and by creating matching slopes that reach a surface model at each incremental location.

You can create corridors with multiple baselines, which enables you to create more complex designs, such as intersections.

Note There is no limit to the number of alignments that can be used to define an AutoCAD Civil 3D corridor.

Corridors are created from and based on existing AutoCAD Civil 3D objects, which include:

- Horizontal Baselines (alignments or feature lines). Used by a corridor as its centerline.
- Vertical Baselines (profiles or feature lines). Used to define surface elevations along the horizontal baseline.
- Surfaces. Used to establish elevations along baselines (by way of profiles or feature lines) and as corridor targets. .
- Subassemblies. A fundamental component of a corridor model. Subassemblies define the geometry of a corridor section (assembly). For example, a typical roadway may be composed of paved lanes (on either side of the centerline), a paved shoulder, a gutter and curb, and a roadside grading. These parts are defined independently as subassemblies. You can stack any type of subassembly to make up a typical assembly and apply the same assembly for a station range along a horizontal baseline.
- Assemblies. Represent a typical section of a corridor. Assemblies comprise one or more subassemblies connected.
- After you have created a corridor, you can extract data from it, including surfaces, feature lines (as polylines, alignments, profiles, and grading feature lines), and volume (quantity takeoff) data.

Note There is no limit to the number of feature lines that can be created at a AutoCAD Civil 3D corridor station or range of stations.

Corridors have their own display style and inherit styles from their components.

Managing and Editing Corridors

A corridor is defined by at least one baseline and an assembly that is applied for a range of stations on that baseline. In many cases, corridors will have different assemblies at different stations, depending on the existing ground and other design requirements. It may be necessary to build a corridor model that is controlled by multiple baselines. To add and edit this type of complexity, you can use the Parameters tab of the Corridor Properties dialog box, where you can modify the associated baselines and assemblies, change assembly frequency and range, and update targets.

You can use the Corridor Properties dialog box to view and or change:

A corridor's information, such as name description, and object style, other parameters such as baselines, frequencies, and targets, code sets, corridor feature lines, surfaces, boundaries, and slope patterns.

Many corridor editing commands can also be accessed on the Corridor ribbon tab.

To display the Corridor tab in the ribbon, do one of the following:

- In the drawing window, click a corridor to select it.

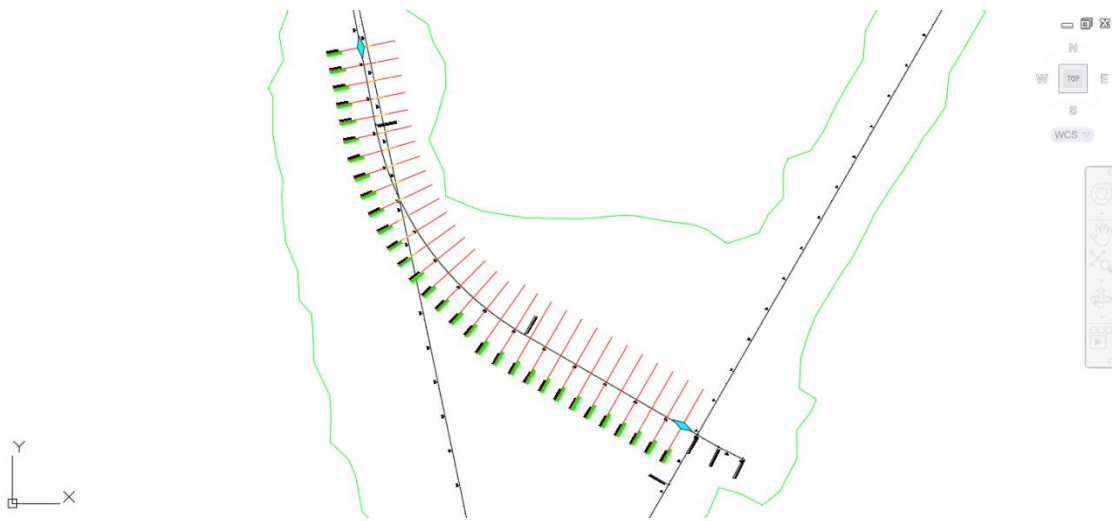

- In the ribbon, click the Modify Tab > Design Panel, then select Corridor.

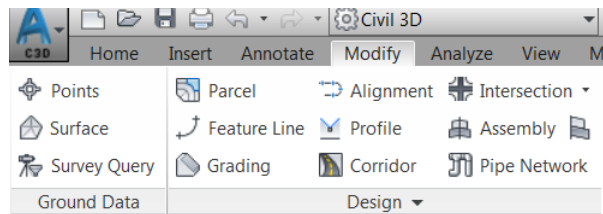

- In Toolspace, on the Prospector tab, right-click a corridor and then click Select.

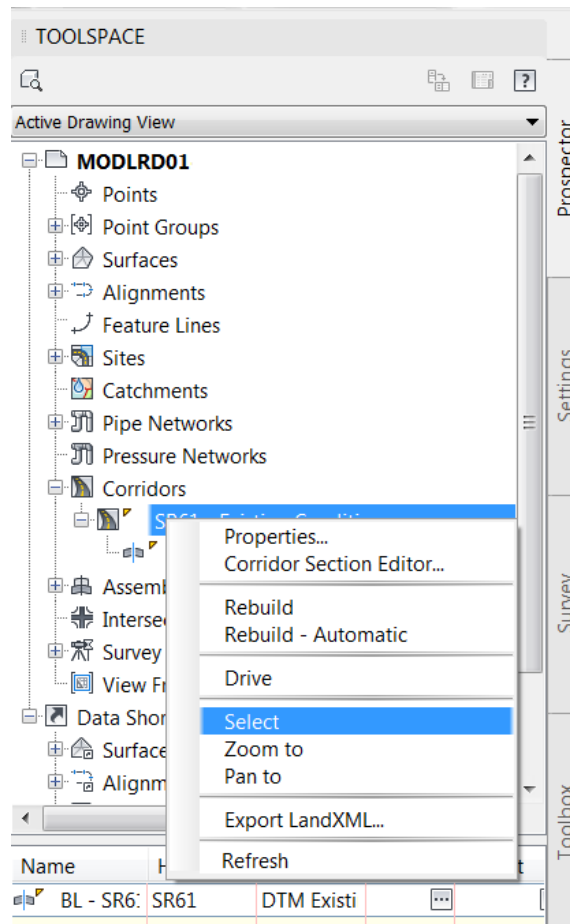

Note You cannot copy a corridor.

WHAT IS A CORRIDOR?

A corridor object is a flexible 3D (three-dimensional) model that combines the horizontal geometry of an alignment, the vertical geometry of a profile, and the cross-sectional geometry of an assembly.

Corridors can be used to model many linear designs such as roads, highways, channels, railways, trenches, tunnels...

In a transportation project the corridor is a critical element of the 3D model. Use Autodesk Civil 3D and the FDOT State Kit to create corridors that meet FDOT CADD standards.

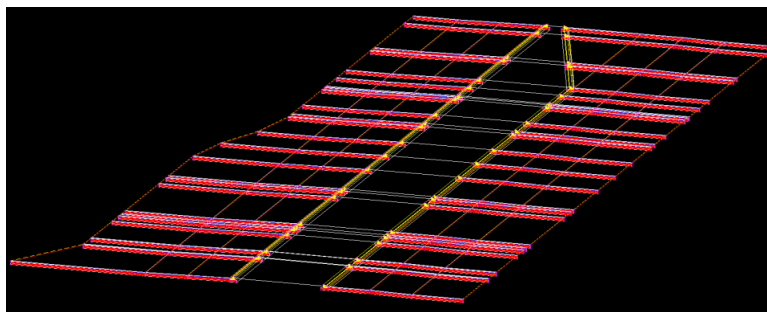
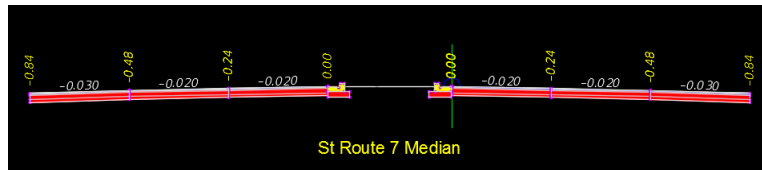

WHAT ARE THE COMPONENTS OF A CORRIDOR?

Corridors contain Five components: Baseline, Assembly, Region, Frequency & Targets.

- **Baseline** - First component for any Corridor. Baseline or Alignment must contain the horizontal layout, and a profile providing the vertical layout.

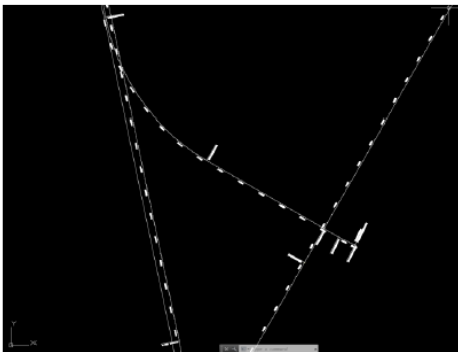

Name	Horizontal Baseline	Vertical Baseline	Assembly	Start Station	End Station	Frequency	Target	Overrides
Baseline	SR01	SR01-PR		699+00.00	714+00.00			
SR01 Left Turn Lane Traffic Separator			SR01 Left Turn Lane Traffic Separator Right Side	701+00.00	703+00.00	25.00		
SR01 Right Turn Lane Traffic Separator			SR01 Right Turn Lane Traffic Separator Left Side	703+00.00	705+00.00	25.00		
SR01 Typical			SR01 Typical	705+00.00	711+00.00	25.00		
SR01 Left Turn Lane Traffic Separator			SR01 Left Turn Lane Traffic Separator	711+00.00	713+00.00	25.00		
SR01 Right Turn Lane Traffic Separator			SR01 Right Turn Lane Traffic Separator	713+00.00	715+00.00	25.00		

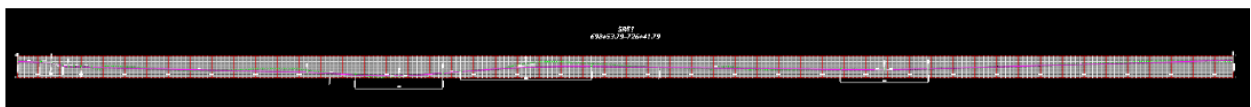

- **Assembly** - Assemblies are required to generate the corridor by providing cross-sectional information to be applied along some of all of the length of the baseline. Assemblies contain the subassemblies that are coded with marker points, links and shapes that generate roadways, curbs, sidewalks...

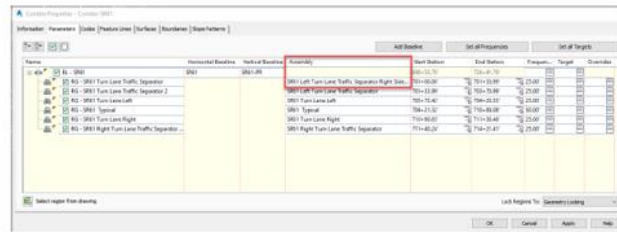
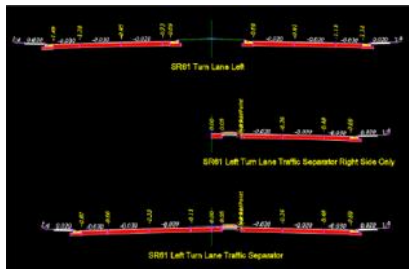

- **Region** - When the geometry along a base line requires a new or single assembly, a new region is needed. A start and end station is with no overlapping is required.

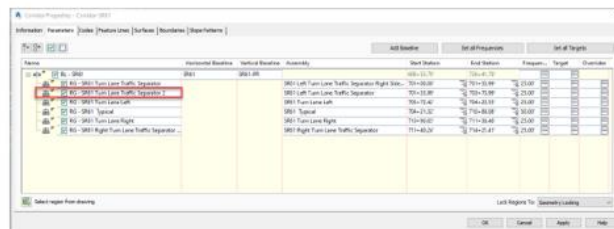
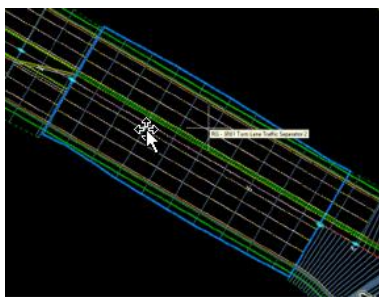

- **Frequency** - Frequency refers to how often the assembly is applied to the corridor. You specify the frequency and placement settings for station along the corridor. The higher the frequency, the greater the detail. High frequency could also result in slow rebuild and over all slow drawing operation performance.

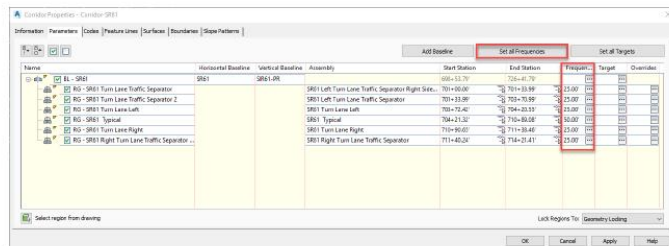

- **Targets** - Targets are used to change the corridor geometric characteristics such as cross slope (elevation targets) and lane width (width targets). Width Targets can be Alignments, polylines, feature lines, or survey figures. Surface targets can be used for daylighting. Refer to each assembly help file for a detailed explanation for targeting options.

Target Parameters
This section lists the parameters in this subassembly that can be mapped to one or more target objects, such as a surface, alignment, or profile object in a drawing. For more information, see Setting Targets in the AutoCAD Civil 3D User's Guide Help.

Parameter	Description	Status
Lane Width Target	May be used to override the input lane Width and tie the edge-of-lane to an offset alignment. The following object types can be used as targets for specifying this: alignments, polylines, feature lines, or survey figures.	Optional
Target Profile	May be used to override the normal lane slope and tie the outer edge of the travel lane to the elevation of a profile. The following object types can be used as targets for specifying this elevation: profiles, 3D polylines, feature lines, or survey figures.	Optional

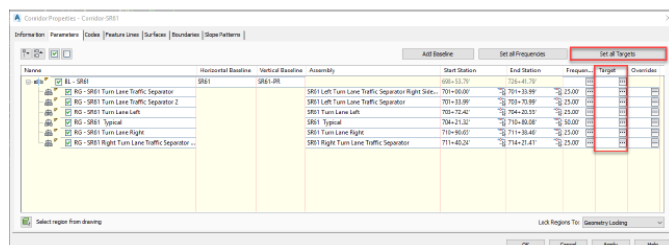

WHAT IS AN ASSEMBLY?

Assembly objects contain and manage a collection of subassemblies that are used to form the basic structure of a 3D corridor model. An assembly is an AutoCAD Civil 3D drawing object that manages a collection of subassembly objects. Together, assemblies and subassemblies function as the basic building blocks of a roadway or other alignment-based design. An assembly object must be applied along an alignment to form a corridor, and it can reference one or more offsets.

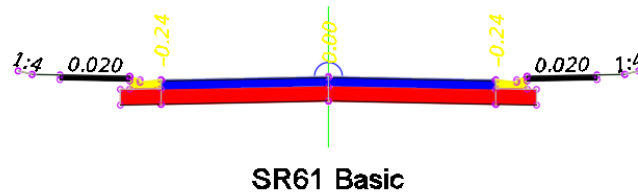

Adding one or more subassembly objects, such as travel lanes, curbs, and side slopes, to an assembly baseline creates an assembly object. This forms the design for a corridor section. The subassemblies are provided in a set of catalogs.

Below is a Roadway assembly (left), with subassemblies shown in a tool palette (right):

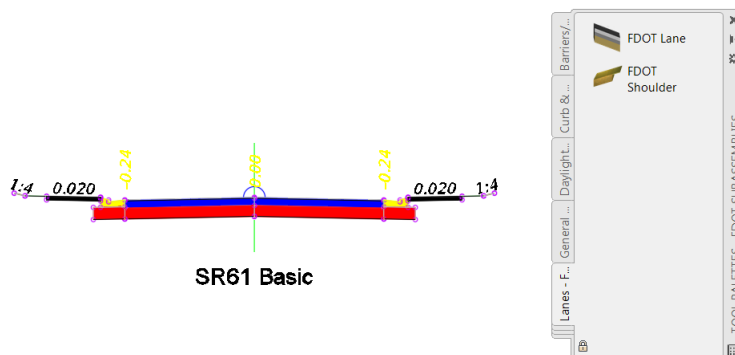

The following graphic shows a simple assembly object that represents one side (lane) of a two-lane road. Subassembly objects named BasicLane and BasicCurbAndGutter have been added to a baseline alignment, forming a single travel lane with a curb and gutter.

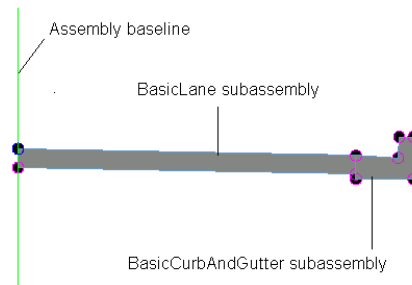

It is also possible to create more advanced assemblies referred to as conditional assemblies. A conditional assembly contains one or more conditional subassemblies, which apply subsequent subassemblies when specified conditions at a given station are met.

The following components comprise an assembly object:

- ***Insertion Point.*** This is the initial point in the drawing that is selected to create the assembly object. It corresponds to the centerline of the eventual corridor object. This is also known as the ground reference point and typically follows an alignment as well as a design profile (vertical alignment).
- ***Baseline.*** The baseline of an assembly typically displays as a visual aid (marker) representing a vertical axis at the assembly baseline point. If you want to attach a subassembly to the baseline point, you can do so by selecting the baseline marker. This method of attaching subassemblies to an assembly is sometimes easier than selecting the baseline point, especially when there are already one or more subassemblies attached at that point.
- ***Baseline Point.*** This is a point on the assembly typically representing the start point of the first subassembly that is attached to the assembly near the controlling alignment. By default, the baseline point coincides with the insertion point and therefore follows the centerline alignment and profile. If you want to begin sectional elements oriented away (horizontally and vertically) from the centerline, do so by moving this baseline point away from the assembly insertion point.
- ***Offset Line.*** The offset line is a typically vertical line visually representing a vertical axis at the offset point. If you want to attach a subassembly at an offset point, you can do so by selecting the offset line marker instead of selecting the offset point. This method of attaching subassemblies to an assembly offset point is sometimes easier than selecting the offset point, especially when there are already one or more subassemblies attached at that point.
- ***Offset Point.*** This is a point on the assembly representing the ground reference point along an offset alignment for the eventual corridor object. Subassemblies attached at this point follow an offset alignment and its designed profile. For example, in the case of a highway with service roads on one or both sides, the service road centerlines are represented by offset points. There is always just one baseline point on an assembly, and there can be zero or many offset points on an assembly. Offset points can be added to or deleted from an assembly at any time.

To complete the definition of an assembly object, you typically add multiple subassembly objects, such as lanes, curbs, or ditches, along an alignment. Each subassembly can connect to the assembly baseline point, any assembly offset point, or to another subassembly already associated with the assembly. A subassembly can also be attached to these points with a relative offset and/or elevation from the point.

Note There is no limit to the number of slope segments a user may define in an AutoCAD Civil 3D assembly.

After creating assembly objects, you can proceed with other corridor modeling tasks, such as creating corridor objects, feature lines, and section views.

CREATING AN ASSEMBLY

When you add a set of subassemblies sequentially to a baseline (for example, lane, curb, sideslope, then ditch), they are all added to the same subassembly group. The next time you select the assembly baseline, a new group is created, and the subsequent subassemblies added belong to the new subassembly group.

1. Click Home tab > Create Design panel > Assembly drop-down Create Assembly

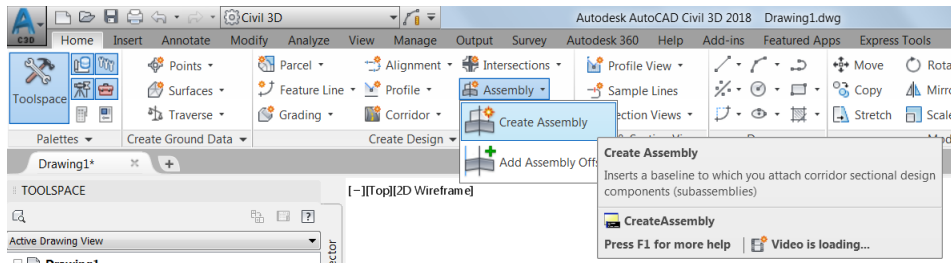

2. In the Create Assembly dialog box:
3. In the Name field, enter a name for the assembly.

Note To name the assembly, select its default name and enter a new name, or you can use the Name Template.

4. For Description, enter an optional description of the assembly.
5. For Assembly Type, select the type of corridor in which the assembly will be used.
6. For Assembly Style and Code Set Style, either accept the default style, select another style, or create a new style.

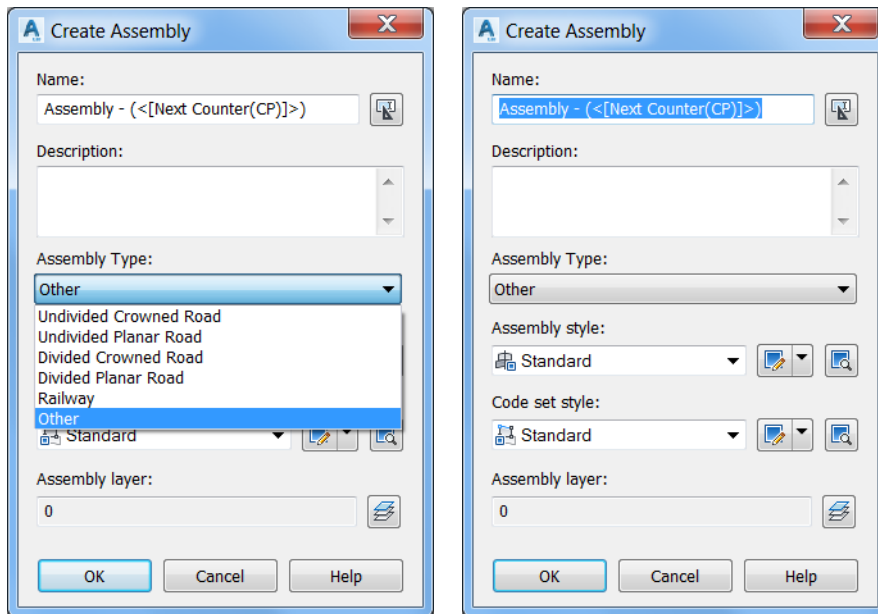

7. Click OK.

8. To insert the assembly into the drawing, click a baseline location in the drawing. The assembly name is displayed under the Assemblies collection in the Prospector tree. A vertical line with a circular marker in the middle is inserted into the drawing. This is the assembly baseline location point, where you will attach one or more subassemblies.

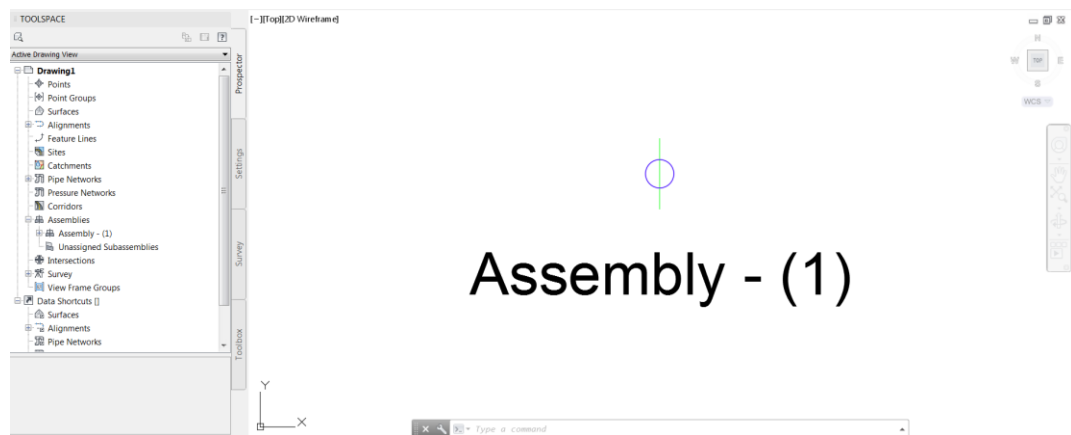

WHAT ARE SUBASSEMBLIES?

A subassembly is a building block of a typical section, known as an assembly. Examples of subassemblies include lanes, curbs, sidewalks, railing, trenches, daylighting, and any other component required to complete a typical corridor section.

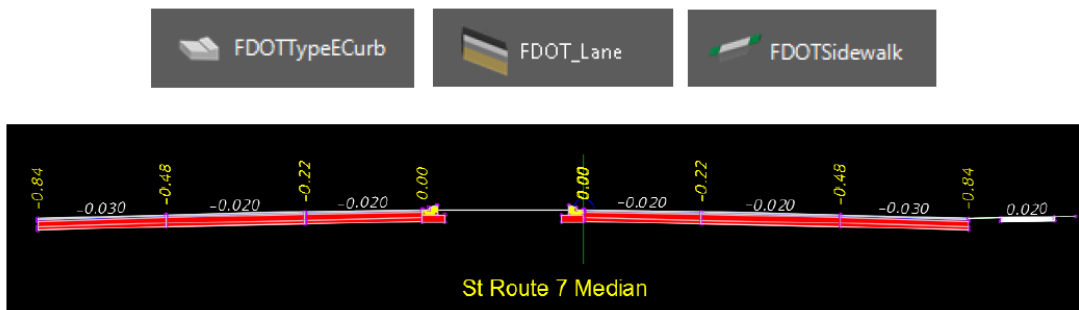

ADDING SUBASSEMBLIES TO AN ASSEMBLY MARKER

You can add subassemblies to a drawing using the subassemblies provided through the AutoCAD Civil 3D tool palette or tool catalog or create your own custom subassemblies.

To open the Tool Palette from the Home tab > Palettes panel click the Tool Palettes icon to open the Tool Palette.

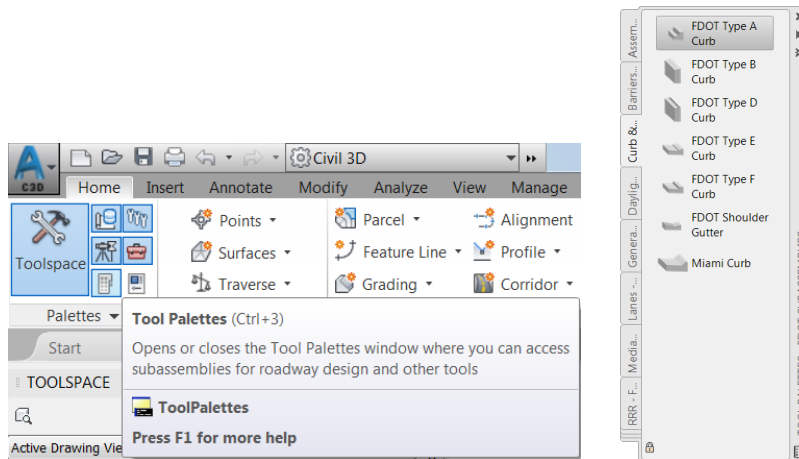

To select the FDOT Subassemblies Palette, right-click on the Tool Palette title bar, then select FDOT Subassemblies.

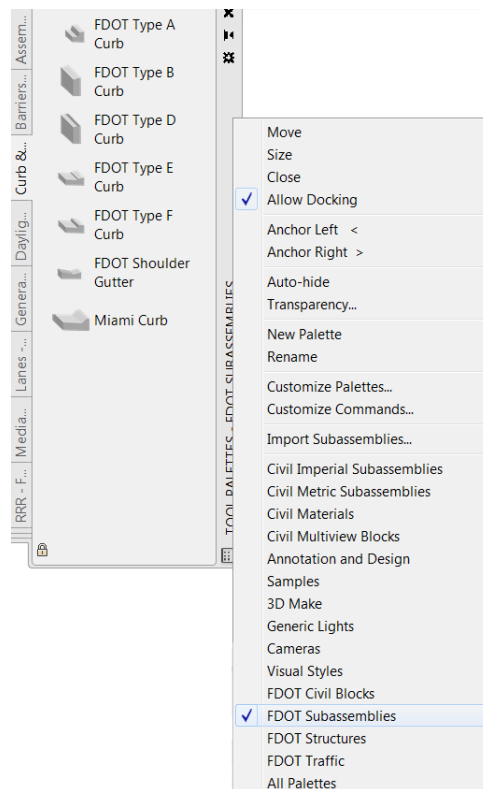

To reveal all the available tabs in the FDOT Subassemblies palette, right-click on the cascading tabs at the bottom of the Tool Palette.

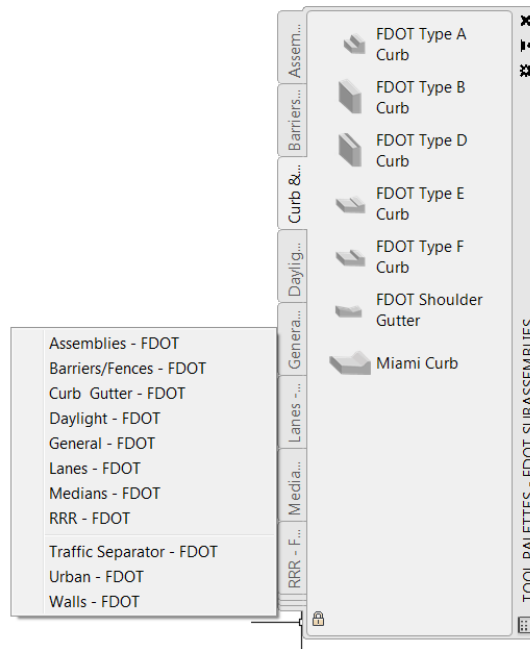

When using the preconfigured FDOT Civil 3D subassemblies, adding the subassembly to the drawing creates the subassembly object.

If you want to draw a custom shape and use it as a subassembly, use the Create Subassembly from Polyline feature. From the Home Tab > Create Design Panel, select Create Design Panel name to expand more commands, then select Create Subassembly from Polyline icon.

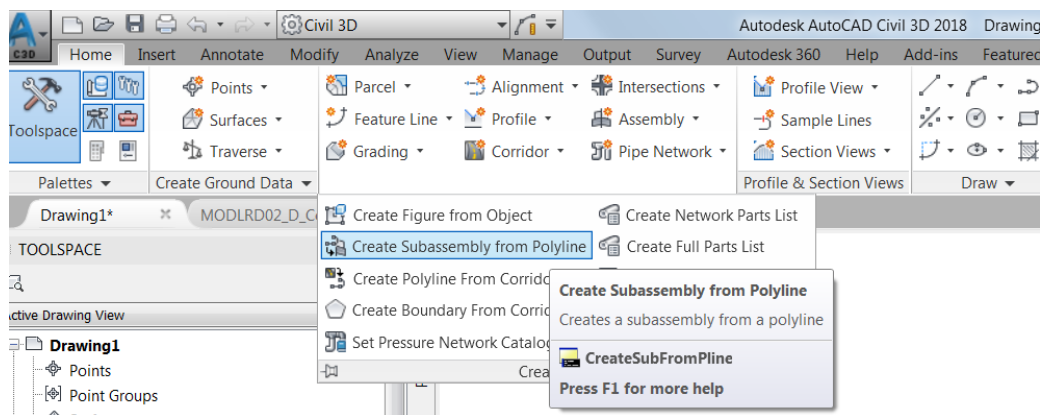

Another approach to creating customized subassemblies is using the Autodesk Subassembly Composer for AutoCAD Civil 3D. This method provides you with the ability to create custom subassemblies with simple or complex conditional behavior built in.

WHAT ARE THE ELEMENTS OF A SUBASSEMBLY?

Subassemblies are composed of three elements: Point, Links and Shapes. Each piece is used for different purposes at each stage of your design process. Below is a schematic showing the parts of a subassembly.

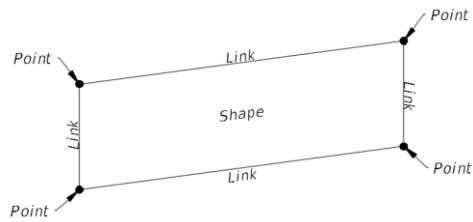

POINTS:

- Marker points are located at the endpoints of every link.
- Used to “click” subassemblies together or “hook” to alignments and/or profiles known as targets.
- Controls automatic labeling.
- Coded points are used to connect the dots between each occurrence/frequency of the assembly.
- Creates feature lines which can then be used almost anywhere.

Points and point codes on the FDOT sidewalk subassembly are displayed below:



LINK:

- Linear components that usually represent the outer edges of an assembly.
- Links have codes assigned to them that identify stratum materials and shapes.
- You can add Custom Codes to some FDOT Subassemblies.
- Controls automatic labeling.
- Simplifies surface creation. Top and datum codes are used to build surfaces.

Links and link codes on the FDOT sidewalk subassembly is displayed below:

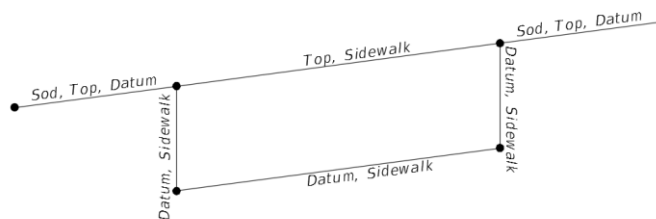

SHAPE:

- Shapes are the areas inside a closed formation of links.
- Shapes are used for creating volumes or end-area material quantity calculations.

Shape codes on the FDOT sidewalk subassembly is displayed below:

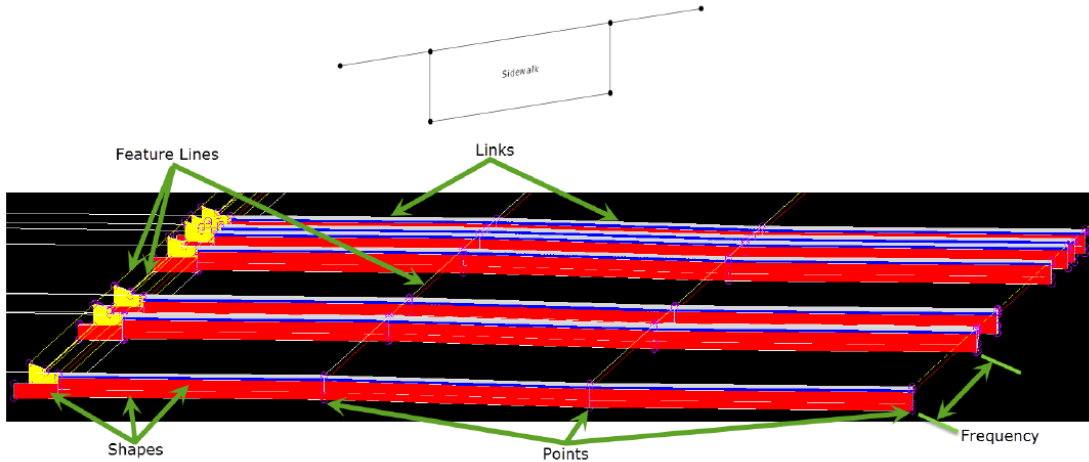

TYPICAL SECTION DETAIL:

The following graphic shows an example of a Typical Section of a road design used to create an Civil 3D Assembly which can be used in the building of a Corridor Model.

Typical Detail

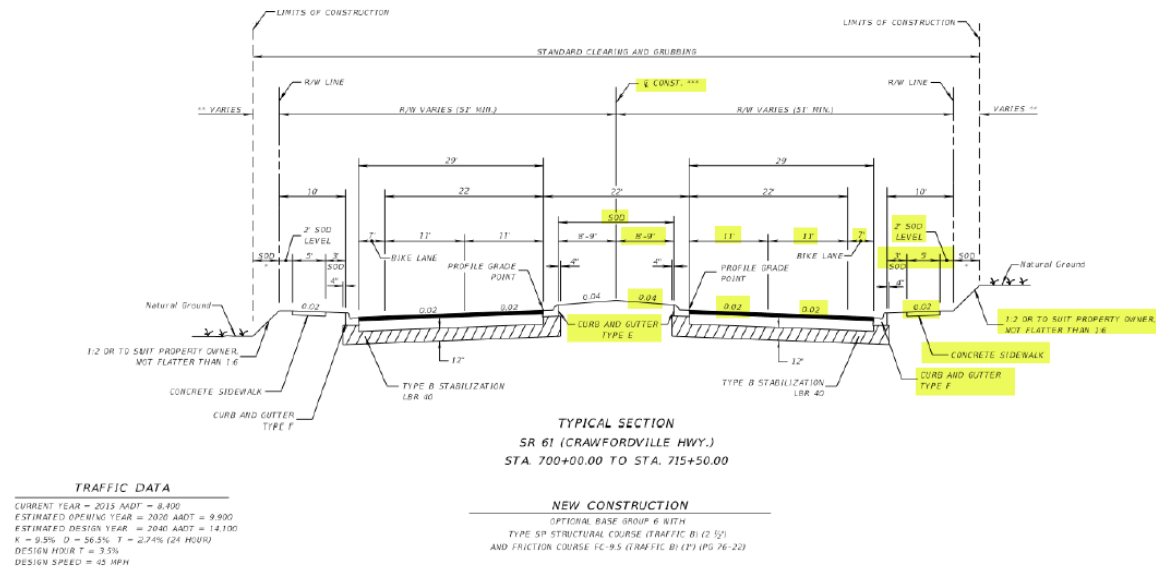

Civil 3D Assembly

CORRIDOR FEATURE LINES.

When a corridor is created feature lines are generated. Feature lines are drawn along the corridor, connecting points with identical codes in between assembly frequencies.

Feature lines can represent back of curb, top of curb, edge of pavement, crowns.

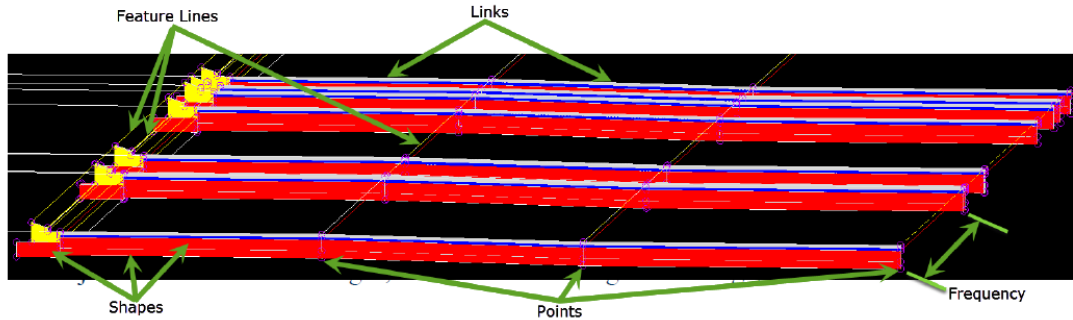

SPECIAL PURPOSE CORRIDORS FOR C3D

Tool Palette – FDOT Subassembly

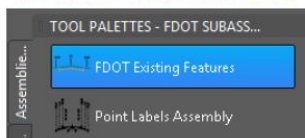

Assembly



Corridor

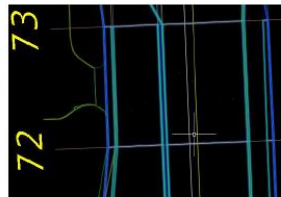

Cross Sections

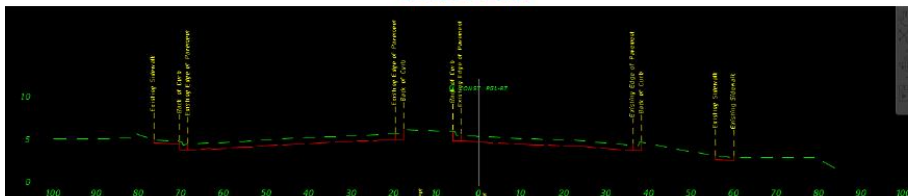

Existing Features

This subassembly searches a set width at each station for intersecting plan graphics and creates a corridor with below ground features; pavement, curbs, shoulders, sidewalks, as well as at grade traffic separators, guardrails and fences for cross sections. It then draws existing features that connect to the defined surface.

TYPICAL WORKFLOWS

WORKFLOW: TO CREATE CORRIDORS

This section provides the processes used to create corridors.

- Create a corridor - Use the Create Corridor command.
- Modify the corridor - Make any required customizations to settings or styles for the corridor.
- Modify or override individual corridor stations - Override corridor and assembly parameters and apply the overrides to a station or range of stations.

WORKFLOW: TO EDIT A CORRIDOR IN SECTION VIEW

This section provides the process used to create and edit corridors in section view.

- Create a corridor - Specify a baseline alignment and profile, but do not create regions or specify assemblies.
- Open the section editor - Use the section editor to view cross sections of the corridor model while either creating or editing a corridor.
- Specify other objects to display in the section editor - Specify which AutoCAD Civil 3D objects you want to represent in section.
- Navigate to a station - Use the section editor tools to navigate to a corridor station. You can even view a section that is between corridor stations.
- Create a corridor region - Drag and drop an assembly from the Prospector, a Tool Palette, or a catalog, and then specify the targets and station range for the region.
- Change region assemblies as desired - Specify a new region assembly either from a list, or by dragging and dropping from Prospector, a Tool Palette, or a catalog.

WORKFLOW: TO VISUALIZE CORRIDORS

After you have created a corridor, create corridor surfaces and boundaries to help you visualize the corridor.

- Create a corridor surface - When you create a corridor surface, it is added to the Surfaces collection.
- Create corridor boundaries - Use corridor surface boundaries to prevent triangulation outside of the daylight lines of a corridor surface.
- View corridor sections - You can use the View/Edit Corridor Section Tools to visually inspect how assemblies are applied at various stations.
- Render a corridor boundary region - Render corridor data using the AutoCAD Render command.

WORKFLOW: TO EXPORT CORRIDOR DATA

After creating a corridor, you can export several types of data.

- Export corridor feature lines - Export corridor feature lines as alignments, grading feature lines, profiles, or polylines.
- Export corridor points as COGO points - Export all points from a selected corridor or constrain the selection based on station ranges or point code types.
- Export corridor surfaces as disconnected surfaces - Exported surfaces are no longer part of the corridor.

Note An exception: if you set pre-defined static alignments as offsets, it is expected that you will specify profiles too. No dynamic offset profiles will be created. Creating new corridor regions for the existing corridors in the intersection area, or creating new corridor objects in the intersection area

3 Basic Civil 3D Functions

DESCRIPTION

This chapter will cover basic Civil 3D functions covering the Toolspace, Workspaces, the Civil 3D Ribbon, FDOT Tab, Civil 3D Menus, the Panorama window, and Layout Toolbars.

OBJECTIVES

In this chapter, you will learn about:

- Toolspace
 - Prospector Tab
 - Settings Tab
 - Survey Tab
 - Toolbox Tab
- Workspaces
- Civil 3D Ribbon
- FDOT Tab
- Civil 3D Menus
- Panorama window
- Layout Toolbars

CHAPTER SETUP

Run the Chapter 3 - 22049555201.exe file and restore all files to the **C:\Civil 3D 2017** Projects folder.

Do not change the location in which the Practice Files are installed. Doing so can cause errors when completing the exercises in this training manual.

Note Some of the content in this chapter is from the Civil 3D 2018 Help file and has been edited to follow the FDOT workflows.

CIVIL 3D TOOLSPACE

In AutoCAD Civil 3D, design data is organized as object collections in the Toolspace window. In Toolspace, the Prospector tab displays the hierarchy of design objects, such as points, surfaces, and alignments.

TOOLSPACE PROSPECTOR TAB

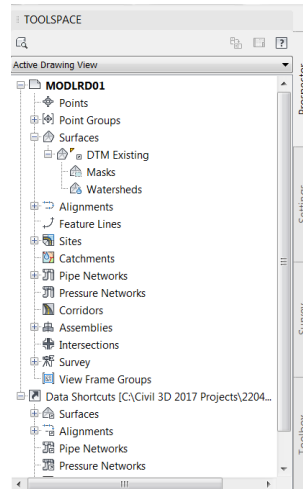

You can use the Prospector tab to manage project and drawing objects. All of the objects in a drawing or project are arranged in a hierarchy.

The Prospector Tab contains the following top-level collections, which can be viewed using the Master View:

- Open Drawings
- Data Shortcuts
- Drawing Templates
- Projects

Important! *The Projects collection in the Prospector Tab is not visible if you have not installed Autodesk Vault client and server applications. During a drawing session, the Projects collection lists the projects that are available after you have logged into an Autodesk Vault server and Vault database.*

Control the items displayed in the Prospector Tab by using the drop-down list at the top of the Prospector tab to control which items are displayed in the Prospector tab.

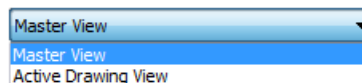

- Master View - Displays all project and drawing items, including drawing templates. The name of the active drawing is highlighted.
- Active Drawing View - Displays only items in the active drawing. If you switch to another drawing, the tab is updated to reflect the new drawing.

Standard context menu commands are available for many Prospector tab items and collections. To display the context menu, right-click a collection or item in the Prospector tab.

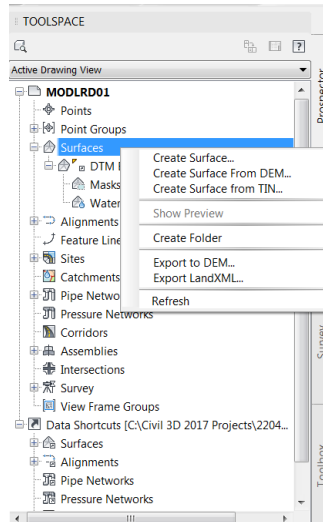

The following commands are available on the Prospector context menu whenever they are applicable to the selected item(s):

Select this context menu command...	If you want to do this...
Properties	View or edit the properties of the selected item or items.
Edit	Edit the selected item or items.
Delete	Delete the selected item or items.
Select	Selects the item or items in the drawing.
Zoom To	Zoom the drawing to the selected item or items contained in the collection.
Pan To	Pan the drawing to the selected item or items contained in the selected collection.
Create Folder	Create a folder within an object collection which you can use for organizing objects. You can drag-and-drop existing objects into the folders, and you can place folders inside other folders.
Export LandXML	Export information using LandXML.
Refresh	Update the items displayed in the Prospector tree.

Note Some Prospector context menus do not include all the commands in the preceding table. Also, a Prospector context menu can contain additional commands that are related to the selected collection or item, including project management access control commands.

TOOLSPACE SETTINGS TAB

You can use the Settings tab to manage styles for AutoCAD Civil 3D objects and to control settings for drawings and commands. Right-click collections and items to access commands.

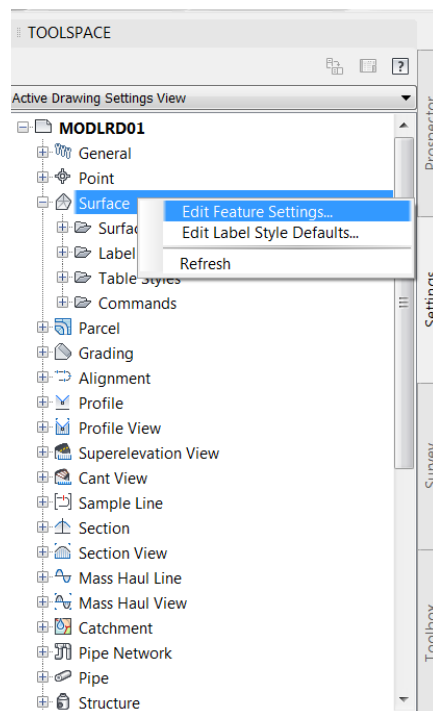

On this tab, styles are organized for different object types. Even in a blank drawing, most of these styles are present in a standard hierarchy. You can create and modify styles in a drawing, then save it as a template. Subsequent drawings based on the template will automatically have the same set of styles available. You can modify object, label, and table styles. You can also control settings for drawings and commands.

Use the Active Drawing Settings View drop-down list at the top of the Settings Tab to control which items are displayed.

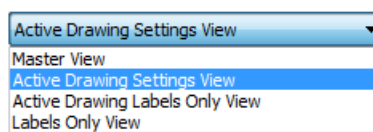

Select one of the following tab views on the Settings tab:

- Master View - Displays items for all open drawings. The name of the active drawing is shown in boldface.
- Active Drawing Settings View - Displays only the items for the active drawing.
- Active Drawing Labels Only View - Displays only label style collections and label styles items for the active drawing.
- Labels Only View - Displays only label style collections and label style items for all drawings.

Use the Settings tab to manage Object, Label, and Table Styles and to control settings for Drawings and Commands. The following graphic shows the top-level collections in the Settings tab:

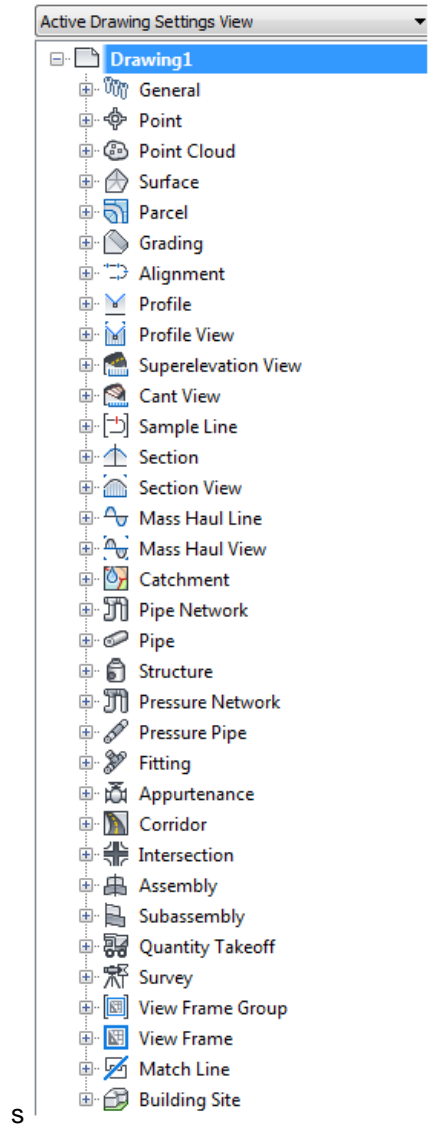

Use the Object collection in the Settings tab to access object styles, settings, and drawing-related information for a class of objects. Most of the object collections conform to a standard layout and use a standard context menu. The following graphic shows an example of a Settings tab Object collection:

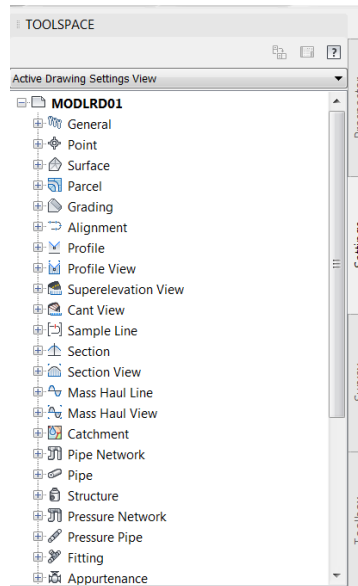

Right-click the Object collection to display a context menu with the following commands:

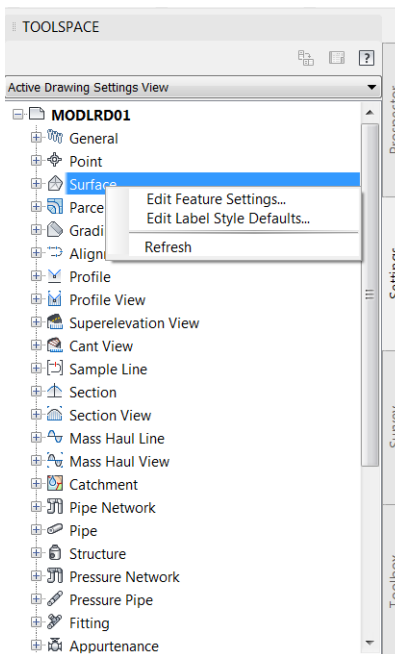

Select this command...	If you want to...
Edit Feature Settings	Modify the settings for all commands that pertain to the object.
Edit Label Style Defaults	Set default settings for all label styles belonging to the object.
Refresh	Update the Settings tree display.

OBJECT STYLE COLLECTION (SETTINGS TAB)

Use an Object’s Styles collection in the Settings tab to manage styles for a class of objects.

The following graphic shows an example of a Settings tab object style collection:

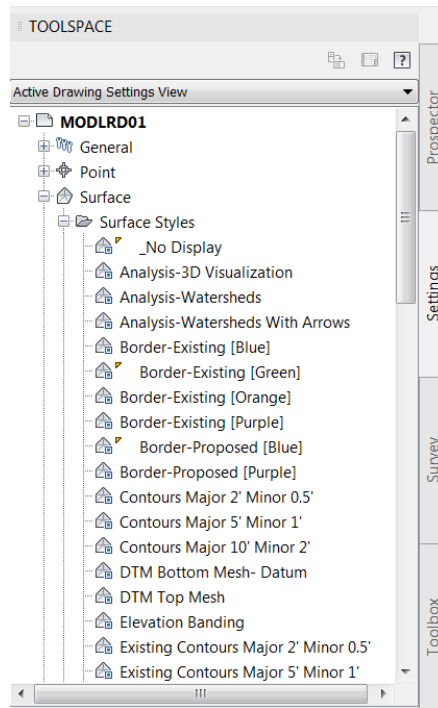

Right-click the Style Collection to display a standard context menu with the following commands:

Select this command...	If you want to...
New	Create a new style.
Refresh	Update the Settings tree display.

Right-click a Style Name to display a standard context menu with the following commands:

Select this command...	If you want to...
Edit	Change the properties of the selected style.
Copy	Create a new style based on an existing style.
Find References	Locate where styles are used in the current drawing. This command is displayed only when the style is in use.
Replace With	Replace the use of a style with another style. This command is displayed only when the selected style is in use.
Delete	Delete the selected style. This command is displayed only when the style can be deleted.
Refresh	Update the Settings tree display.

LABEL STYLES COLLECTIONS (SETTINGS TAB)

Use the Label Styles collections in the Settings tab to create and manage label styles and expressions for a class of objects. Click the +/- box to expand the collection and see the label styles for the object. Some objects have multiple levels of label styles.

The following graphic shows an example of a label style collection:

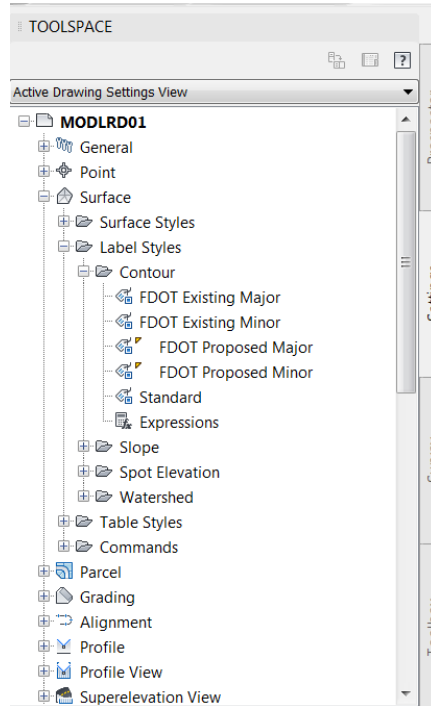

Right-click a label style name to display a context menu that contains the following commands:

Select this command...	If you want to...
Edit	Change the properties of the label style.
New	Create a new child label style.
Copy	Create a new label style based on an existing label style.
Find References	Locate where label styles are used in the current drawing. This command is displayed only when the label style is in use.
Replace With	Replace the use of a label style with another label style. This command is displayed only when the selected label style is in use.
Delete	Delete the selected label style. This command is displayed only when the style can be deleted.
Refresh	Update the Settings tree display.

TABLE STYLES COLLECTIONS (SETTINGS TAB)

Use the Table Styles collections in the Settings tab to create and manage table styles for a class of objects. Click the +/- box to expand the collection and see the table styles for the object. Some objects have multiple levels of table styles.

The following illustration shows an example of a Settings tab table style collection:

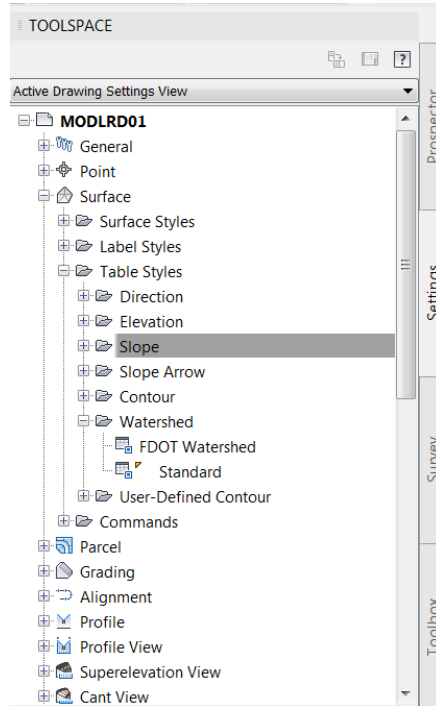

Right-click a table styles collection to display a context menu with the following commands:

Select this command...	If you want to...
New	Create a new table style.
Refresh	Update the Settings tree display.

For detailed information about the settings, click Help in the dialog box that is displayed when you select the menu item.

Right-click a table style name to display a context menu that contains the following commands:

Select this command...	If you want to...
Edit	Change the properties of the table style.
Copy	Create a new table style based on an existing table style.
Find References	Locate where table styles are used in the current drawing. This command is displayed only when the table style is in use.
Replace With	Replace the use of a table style with another table style. This command is displayed only when the selected table style is in use.
Delete	Delete the table style. This command is displayed only when the style can be deleted.
Refresh	Update the Settings tree display.

COMMANDS COLLECTIONS (SETTINGS TAB)

Use the Commands collections in the Settings tab to control the settings for a specific command at the object (feature) level. When you change settings using the Commands collections, the changes affect a single command only.

The following graphic shows an example of a Settings tab commands collection:

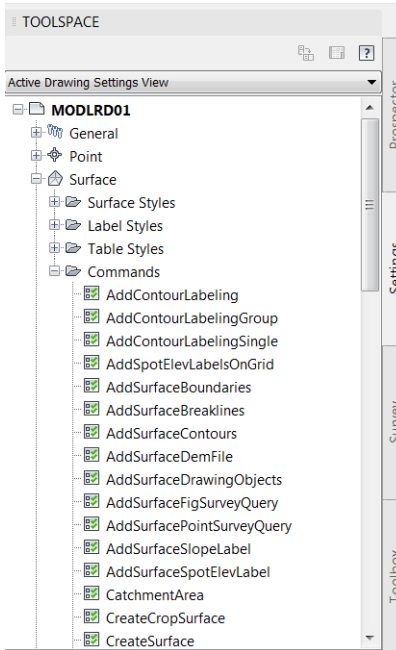

Right-click a command name and click Edit Command Settings to display the Edit Command Settings dialog box for the command. You can then change the settings.

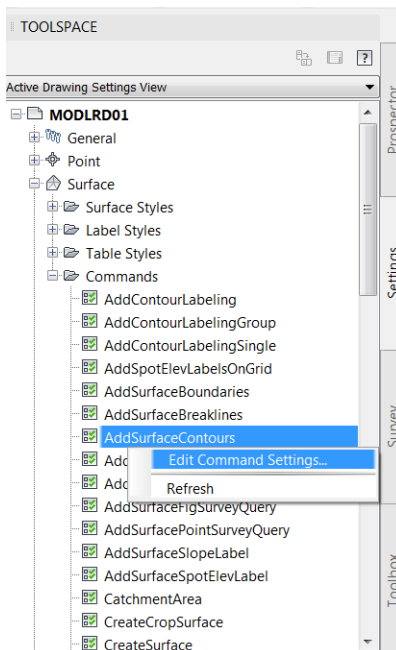

GENERAL COLLECTION (SETTINGS TAB)

Use the General collection to create multipurpose and label styles that can be used by more than one object type. Pipes and Surface objects can share the Render styles in the General Multipurpose Styles collection, while Corridors and Grading share the other styles in this folder. The General Label Styles are used by lines, curves, feature lines, and corridors. This collection also contains Note label styles, which are not specific to an object.

The following graphic shows an illustration of the General collection:

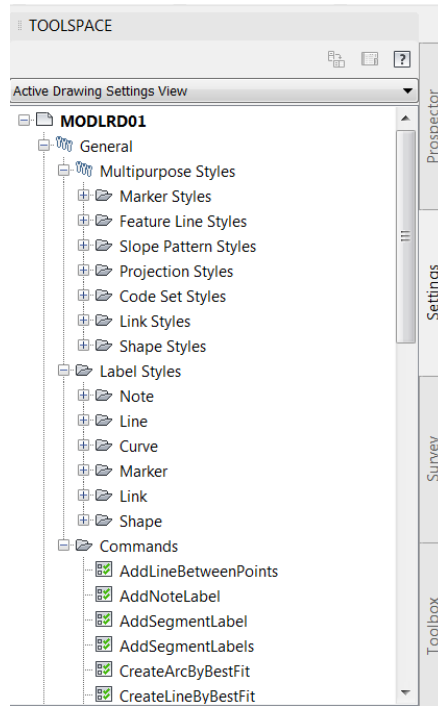

Right-click a style name to display a context menu that contains the following commands:

Select this command...	If you want to...
Edit	Change the properties of the style.
Copy	Create a new style based on an existing style.
Delete	Delete the selected style. This command is displayed only when the style can be deleted.
Refresh	Update the Settings tree display.

WORKING WITH WORKSPACES

Workspaces are sets of user interface components, such as ribbon tabs and panels, toolbars, palettes, and menu bars, that are grouped and organized so that you can work in a custom, task-oriented drawing environment. When you select a workspace, only the user interface components specified in that workspace are displayed. You can still access other commands by entering their command names at the command line.

AutoCAD Civil 3D 2018 comes with a default workspace for working with AutoCAD Civil 3D commands. You can use this workspace as-is or modify it according to your requirements.

Workspaces in AutoCAD Civil 3D 2018 include:

- **Civil 3D:** This workspace displays user interface components related to civil engineering design and survey features available in AutoCAD Civil 3D.
- **Drafting & Annotation:** This workspace displays user interface components related to AutoCAD drafting and annotation features available in AutoCAD Civil 3D.
- **3D Modeling:** This workspace displays user interface components related to AutoCAD 3D modeling features available in AutoCAD Civil 3D.
- **Planning and Analysis:** This workspace displays user interface components related to AutoCAD Map 3D features available in AutoCAD Civil 3D.

➤ **To Change the Current Workspace**

You can switch to another workspace by using the Workspace drop-down menu in the Quick Access Toolbar.

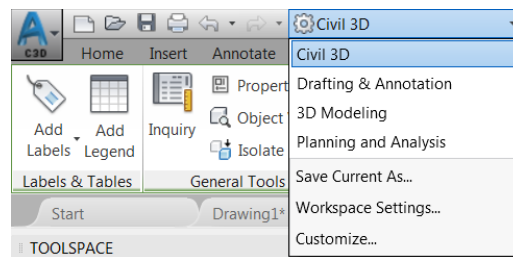

<OR> Use the Workspace Switching button, which is located in the application status bar.

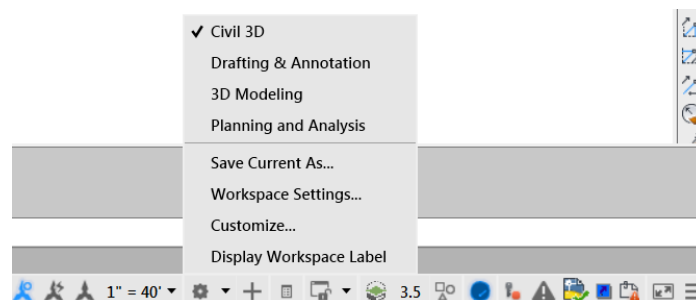

CIVIL 3D RIBBON

The AutoCAD Civil 3D ribbon is the primary user interface for accessing commands and features. Commands available from the ribbon are organized into tabs. Each tab is organized into a series of panels. The ribbon is typically turned on (displayed) by default and can be displayed or turned off by using the Ribbon and RibbonClose commands.

There are two basic types of ribbon tabs: Static and Contextual.

STATIC RIBBON TABS

Static ribbon tabs are always displayed when the ribbon is turned on.

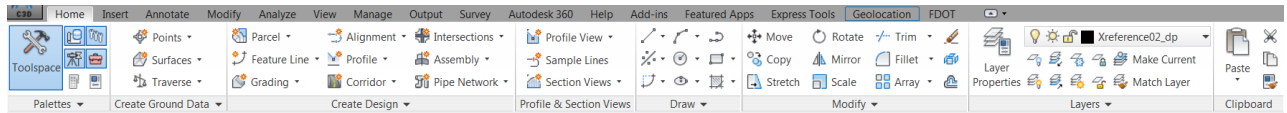

CONTEXTUAL RIBBON TABS

Contextual ribbon tabs are displayed automatically when you select an object or invoke an object-specific command. For example, when you select a pipe network object, the Pipe Network contextual tab is displayed.

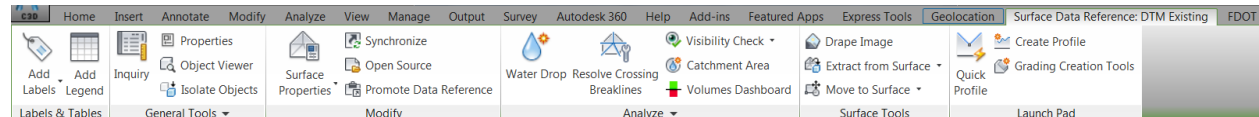

Contextual tabs contain commands that are related to the currently selected object. Most contextual tabs can be closed simply by deselecting the object.

- ***Multiple Contextual Tab*** - When multiple types of objects are selected simultaneously, the Multiple contextual tab is displayed in the ribbon. For example, if you select both a pipe network object and an alignment object, the Multiple contextual tab is displayed.

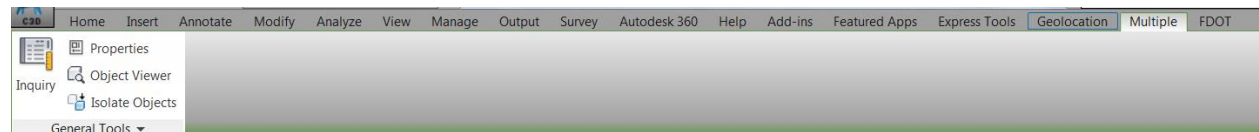

- ***Launch Pad Panel*** - AutoCAD Civil 3D contextual ribbons include a Launch Pad panel that provides access to commands that you might use next in your workflow.

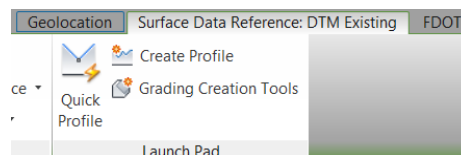

For example, when you select a surface object, the Surface contextual tab is displayed. The Launch Pad panel on the Surface contextual tab provides a variety of commands that you may want to use next. For example, you may want to create a Quick Profile, or Create a Profile from the selected Surface.

FDOT TAB

The FDOT Ribbon Tab is part of the FDOT Civil 3D State Kit and is loaded when the FDOT2018.C3D desktop shortcut icon is used to start Civil 3D 2018. The following graphic shows an illustration of FDOT2018.C3D desktop shortcut:



The FDOT Ribbon Tab contains panels which contain tools for various FDOT Workflows:

- Create File Panel
- Tools Panel
- Pay Item Tools Panel
- Quantities Panel
- Quality Control Panel
- Reports Panel
- GeoTech Panel
- Help Panel

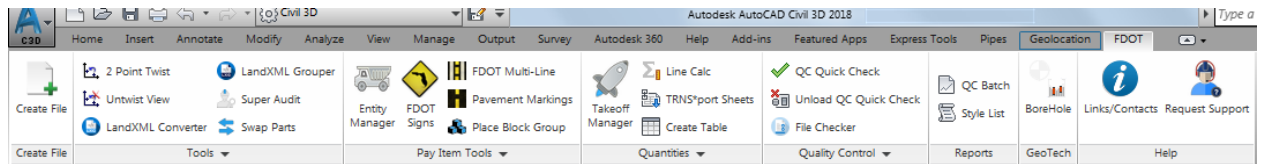

The following FDOT Tab > Panels which display a black arrow next to the panel name display additional tools when the panel name is selected.

- The following graphic shows an illustration of FDOT Tab > **Pay Item Tools** panel.

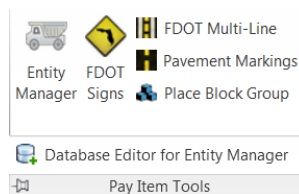

- The following graphic shows an illustration of FDOT Tab > **Quantities** panel.

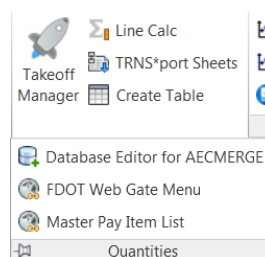

- The following graphic shows an illustration of FDOT Tab > **Tools** panel.

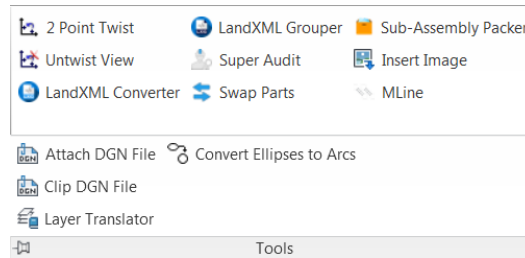

- The following graphic shows an illustration of FDOT Tab > **Quality Control** panel

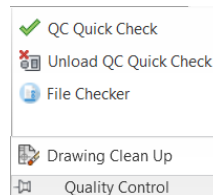

AUTOCAD CIVIL 3D MENUS

While the ribbon is the primary access point for AutoCAD Civil 3D commands, many commands are also available from the application menu and from context menus that are displayed when you right-click an object in Toolspace or in the drawing window.

APPLICATION MENU

The application menu provides access to file-related commands. For example, it provides commands that let you create, open, print, export, and publish a file.

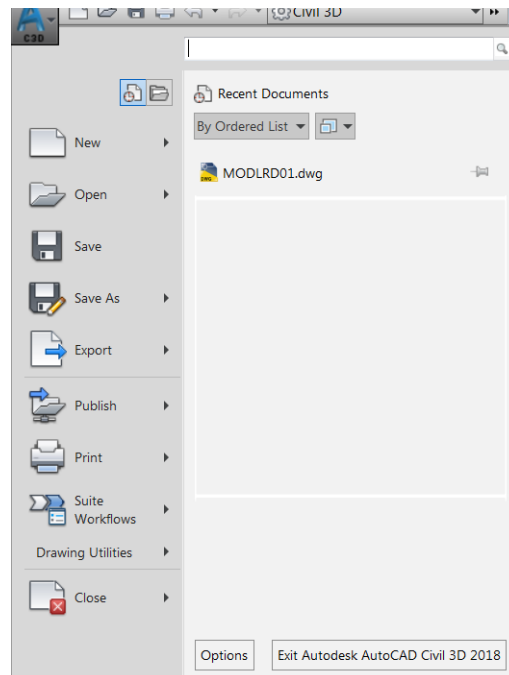

Access the application menu by clicking the application menu icon at the top left of the application window .

The application menu also provides a search tool which you can use to search for commands. Only those commands that are available in the current workspace are shown and searched.

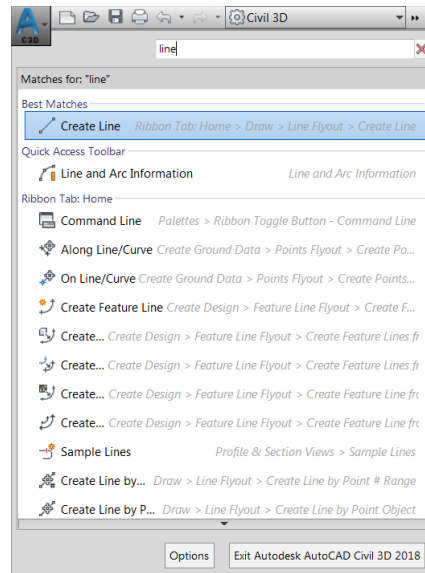

CONTEXT MENUS

Context menus are available throughout AutoCAD Civil 3D. To display a context menu, right-click your pointing device on items in the Toolspace, Panorama, or other window, or on objects in the drawing area.

The following graphic shows an illustration of a right-click in the Drawing Editor with nothing selected:

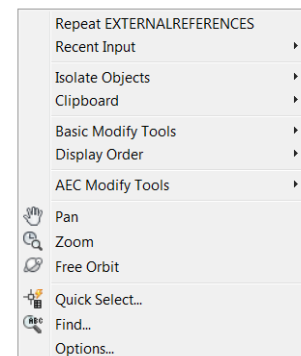

The following graphic shows an illustration of a right-click in the Drawing Editor with a Surface object selected:

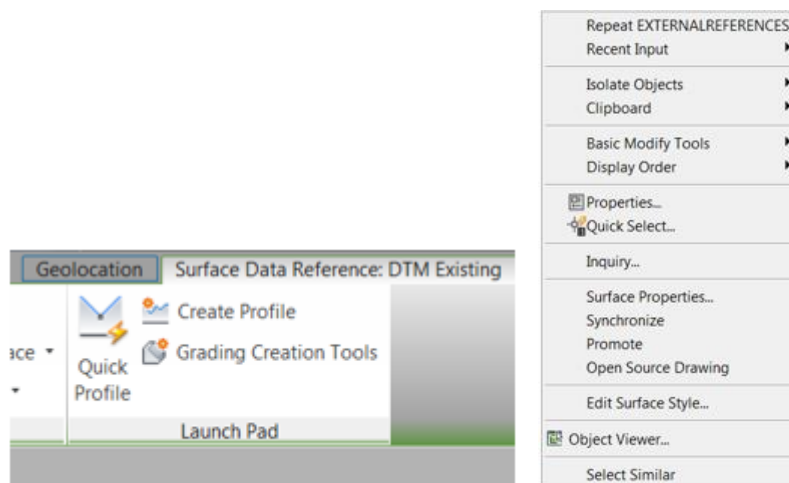

The following graphic shows an illustration of a right-click in the Drawing Editor with a Surface object selected:

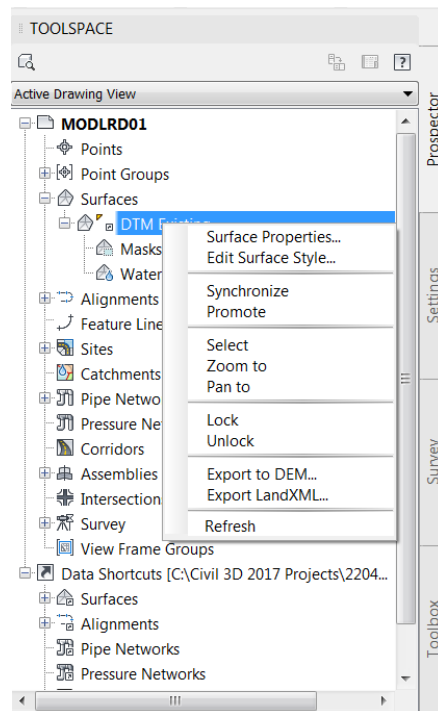

PANORAMA WINDOW

Use the Panorama window to display data in a grid.

The data views that are displayed in the Panorama window are referred to as vistas. The Panorama window can display many types of data, such as the Point Editor vista and the Alignment Entities vista.

Point Nu...	Easting	Northing	Point Elevati...	Name	Raw Descripti...	Full Descript...
1	19857.2577'	20260.4556'	100.306'		GRND	GRND
2	19875.4801'	20207.7198'	101.093'		GRND	GRND
3	19887.3953'	20692.7130'	96.419'		GRND	GRND
4	19888.9069'	21076.9713'	95.436'		GRND	GRND
5	19889.7110'	21205.2833'	97.833'		GRND	GRND
6	19890.2416'	21136.5660'	96.612'		GRND	GRND
7	19891.2471'	20986.9661'	97.474'		GRND	GRND
8	19892.5010'	20942.4705'	97.856'		GRND	GRND
9	19893.3261'	21033.2971'	95.738'		GRND	GRND
10	19895.9462'	20756.7742'	98.717'		GRND	GRND

To conserve screen space if more than one vista is active, the Panorama window displays a tab for each one. Click the tab containing a vista’s name to bring it to the front of the window.



You control the display of some vistas, such as the Point Editor vista. You activate them when you want, and they remain active until you dismiss them by clicking . Other vistas, such as the Alignment Entities vista, are controlled by a specific command. This type of vista can only be activated or closed when the command is running, and its display is controlled from the command toolbar.

The active drawing controls the state of the Panorama window. When you switch between drawings, the Panorama window either becomes inactive or shows only the vistas associated with the active drawing.

You can dock the Panorama window or use Auto-hide to reduce the amount of screen space it requires.

DISPLAYING THE PANORAMA WINDOW

Display of the Panorama window is affected by several factors, such as the active drawing and the active vistas within that drawing. If the Panorama window is not visible, refer to the following table for possible reasons and actions you can take to display it:

Under these circumstances...	Do this...
You cannot see the Panorama window or the title bar.	Click  at the top of the Toolspace window. If the Panorama window contains active vistas, it is displayed. If the button is disabled, the Panorama window contains no active vistas. In some cases, you can display the Panorama window by clicking a toolbar icon.
The Panorama window is displayed, but the vista you want to work with is not displayed.	If the Panorama window has a tab for the vista, click the tab to display the vista. If the named tab is not visible, you must activate the vista. For instructions about activating a specific vista, refer to Help for that vista.
Only the Panorama title bar is displayed (Auto-hide is active).	Move the cursor over the title bar to display the full Panorama window. To disable Auto-hide, click  on the Panorama title bar.

FEATURES OF THE TOOLSPACE AND PANORAMA WINDOWS

The Toolspace and the Panorama windows share several features.

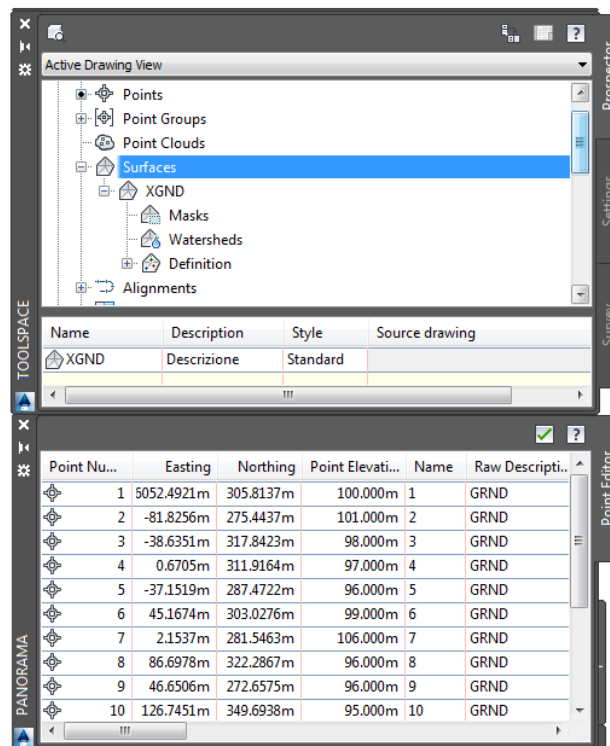

- **Tabs** - The Toolspace window can display up to four tabs: Prospector, Settings, Survey, and Toolbox. The Panorama window displays named tabs if you have more than one vista active in the window.
- **Context Menus** - Right-click in the Toolspace or the Panorama window to display a context menu of available commands. Right-click a single item, or select one or more items and right-click, to display a menu containing commands related to the item(s). If you right-click an area that contains no items or data, the menu contains commands related to the window.

- **Auto-hide** - This AutoCAD palette feature keeps the window active while maximizing the amount of available screen space. If Auto-hide is active for a window, the body of the window disappears when you move the cursor out of the window, leaving only the title bar visible. Move the cursor over the title bar to display the entire window again. The following illustration shows the Toolspace window both closed and open, with Auto-hide active:

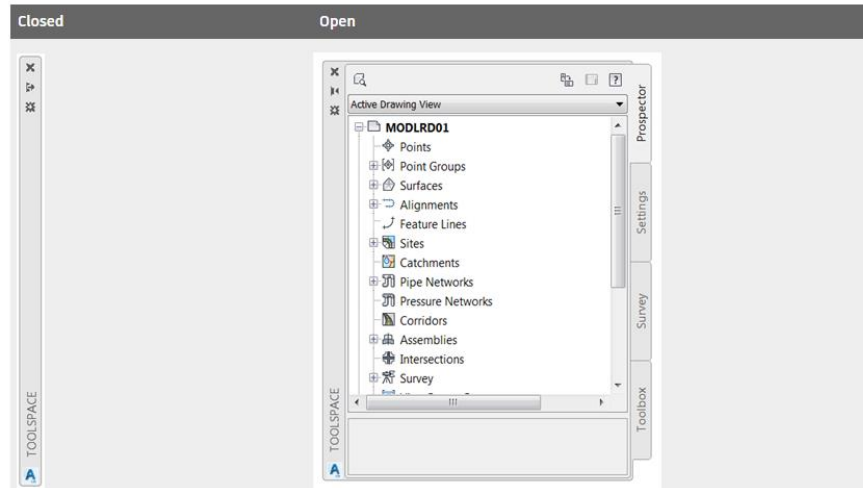

To activate Auto-hide for the Toolspace or the Panorama window, click on the title bar. To deactivate Auto-hide, click on the title bar. You can also right-click the title bar and use the context menu to control Auto-hide.

Important! *Auto-hide is not available when a window is docked.*

- **Moving and Docking** - The Toolspace and the Panorama windows, like all AutoCAD palettes, can be moved and resized, and either floated in the window or docked. A docked window shares one or more edges with adjacent windows and toolbars. If a shared edge is moved, the windows change shape to compensate. To undock and relocate a window, click and drag the control bars at the top or side of the window. To prevent a window from docking while you drag it, hold down Ctrl.

Note You can quickly undock a window by double-clicking the window's control bars.

LAYOUT TOOLBARS

Layout toolbars let you create and or edit AutoCAD Civil 3D objects.

AutoCAD Civil 3D has the following layout toolbars:

- **Alignment Layout Toolbar**

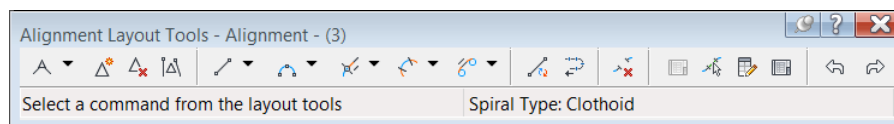

- Grading Creation Toolbar

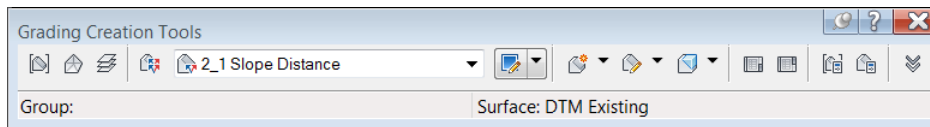

- Parcel Layout Toolbar

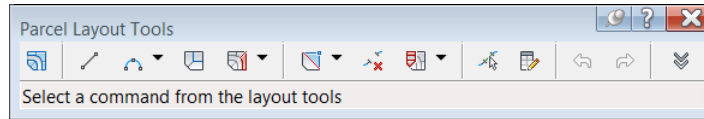

- Pipe Network Layout Toolbar

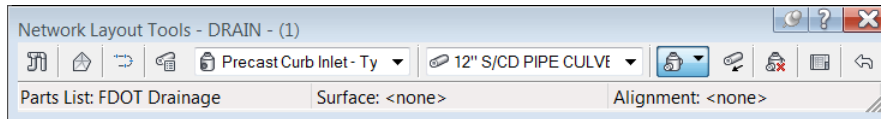



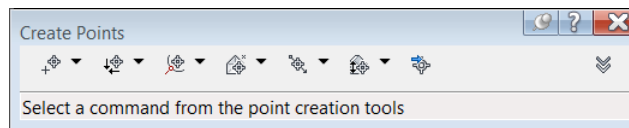

- Point Object Creation Toolbar

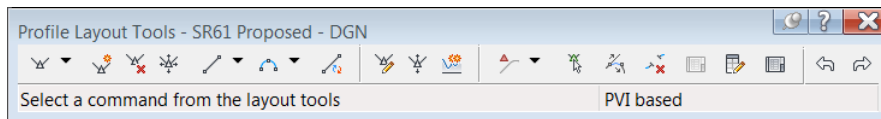

- Profile Layout Toolbar



The icons or commands available on an AutoCAD Civil 3D layout toolbar depend upon the toolbar in use. Most AutoCAD Civil 3D layout toolbars include the following three icons in the upper right corner:

Icon	Purpose
	Pins the toolbar, which places it in a fixed location and also shrinks the toolbar down to a small placeholder when the cursor moves outside the toolbar. To display the expanded toolbar, move the cursor over the placeholder. To unpin the toolbar, click  .
	Displays Help for the layout toolbar.
	Closes the layout toolbar.

For information about the icons and commands that are available from a specific layout toolbar, click the Help button on the toolbar.

4 Creating the GTDMRD01 File

DESCRIPTION

In this chapter you will create the GTDMRD01 file used in the process of creating the SR61 Corridor model. Next you will be importing a LandXML file which contains a DTM surface created by the Survey department. Then Data Shortcuts of the DTM surface will be created.

OBJECTIVES

In this chapter, you will learn about:

- FDOT Create File tool
- Import LandXML file
- Data Shortcuts
 - Set Working Folder
 - Set Data Shortcut Project Folder
 - Associate Project to Current Drawing
 - Creating Data References
- Creating Data Shortcuts
- Review Results

CHAPTER SETUP

Run the Chapter 4 - 22049555201.exe file and restore all files to the C:\Civil 3D 2017 Projects folder.

Do not change the location in which the Practice Files are installed. Doing so can cause errors when completing the exercises in this training manual.

Exercise 4.1 Set Data Shortcuts Paths

In this exercise you will set up the Data Shortcuts paths.

1. Start the FDOT Civil 3D State Kit by double clicking the **_FDOT2018.C3D** icon as shown below:

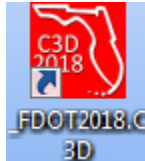

2. Set Data Shortcuts Paths for the 22049555201 project. From *TOOLSPACE* > *Prospector tab* > *Data Shortcuts*, right click to display popup menu and select **Set Working Folder**.

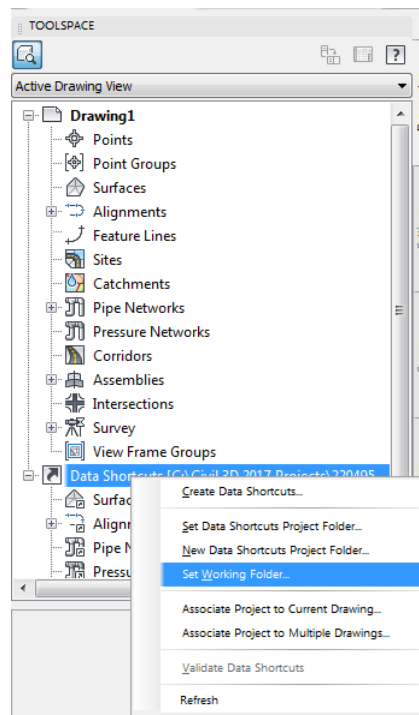

3. From the Browse For Folder dialog box, use the scroll bar to navigate and click on the **C:\Civil 3D 2017 Projects** folder. Click **OK** to close the Browse For Folder dialog.

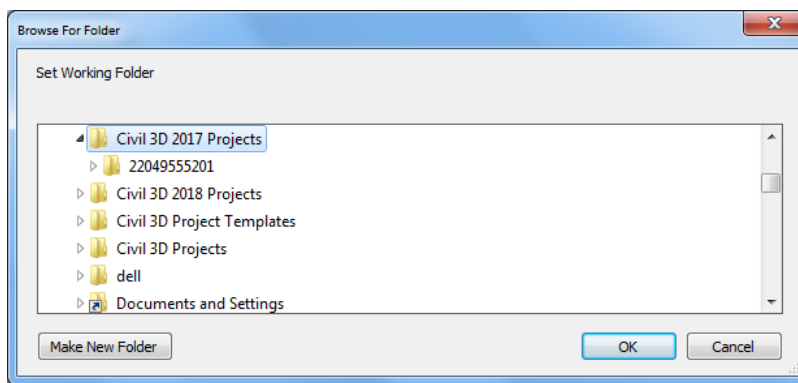

- From TOOLSPACE > Prospector tab > Data Shortcuts, right click and select Set Data Shortcuts Project Folder.

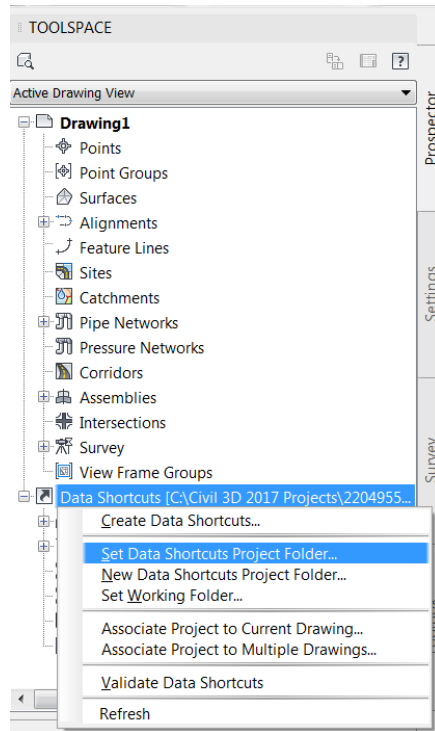

- From the Set Data Shortcut Folder dialog box, select **22049555201** from the list.

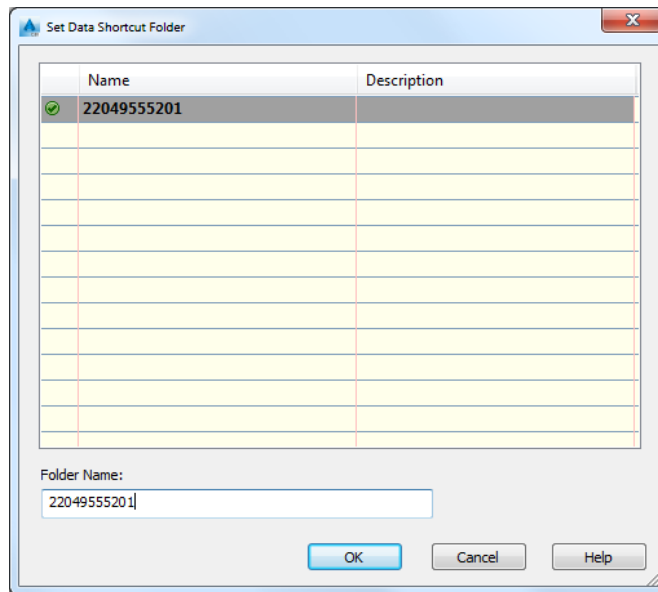

- Click **OK** to close the Set Data Shortcut Folder dialog..

7. The Data Shortcuts are now set to reference the C:\Civil 3D 2017 \Projects\22049555201 folder.

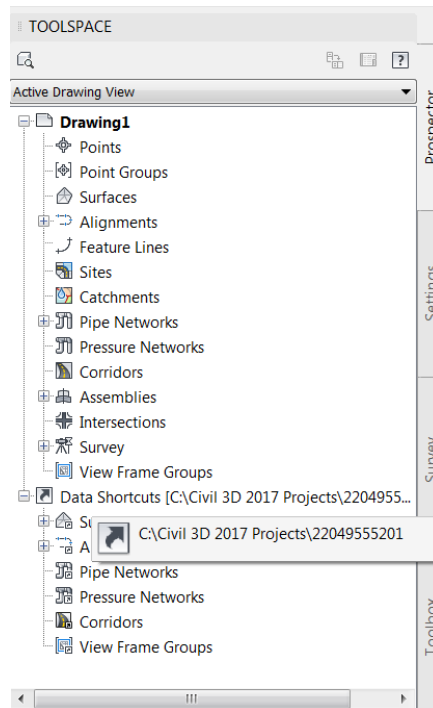

8. From the Status Bar at the bottom of the window toggle **On Selection Cycling** by clicking on the icon as shown below.

Note Selection Cycling is not drawing specific but an option that you can toggle on or off at any time. If a new drawing is created or opened the Selection Cycling option will retain the previous toggle setting.

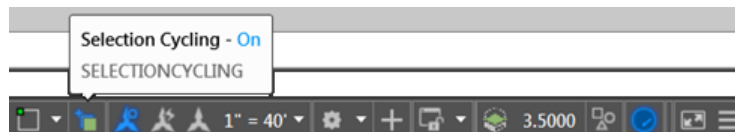

Exercise 4.2 Create a Digital Terrain Model - Tin Model - 3D file GDTMRD01 File

In this exercise you will create the GDTMRD01 file

1. From the FDOT Tab, select the Create Files panel

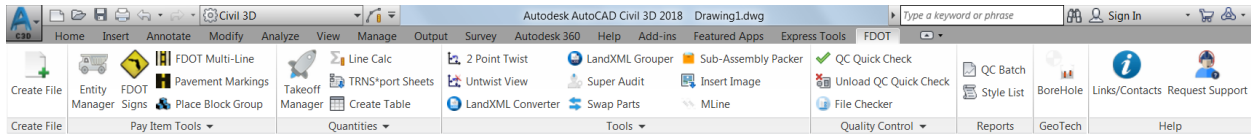

2. Select the Create Files icon

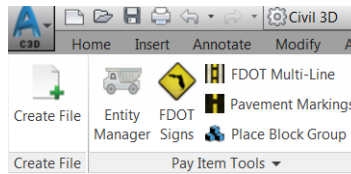

3. Make the project 22041255201 current. (Use Select Project Button)
4. Select Control File: ROADWAY
5. Select File Group: Survey Files (DWG)
6. Select File Type: Digital Terrain Model - Tin Model - 3D(GDTMRD01)
7. Set the GDTMRD01.dwg County to Wakulla
8. Set the GDTMRD01.dwg Coordinate System to FL83-NF
9. Click “Create-Open File” to create GDTMRD01.dwg file

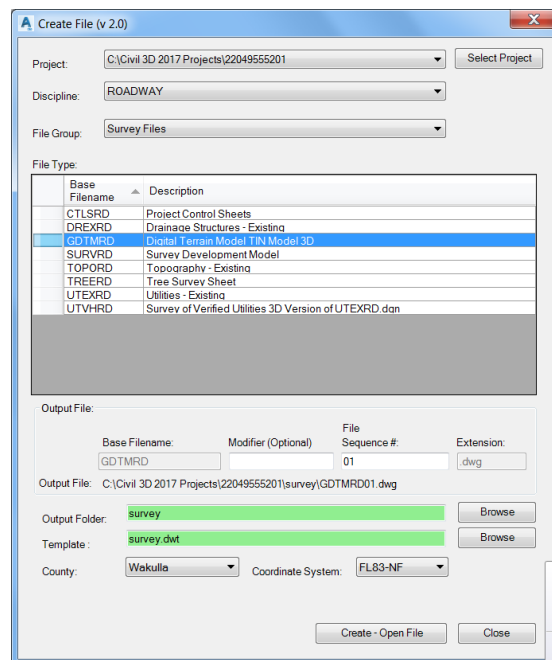

10. Click “Close” to close Create Files Tool
11. Switch to the **GDTMRD01.dwg** file in the current session of Civil 3D
12. **Save** the GDTMRD01.dwg file

Exercise 4.3 Associate Project to Current Drawing

In this exercise you will associate the GDTMRD01 file to the current project.

1. From the TOOLSPACE, Prospector tab, right-click on Data Shortcuts, then select **Associate Project to Current Drawing**.

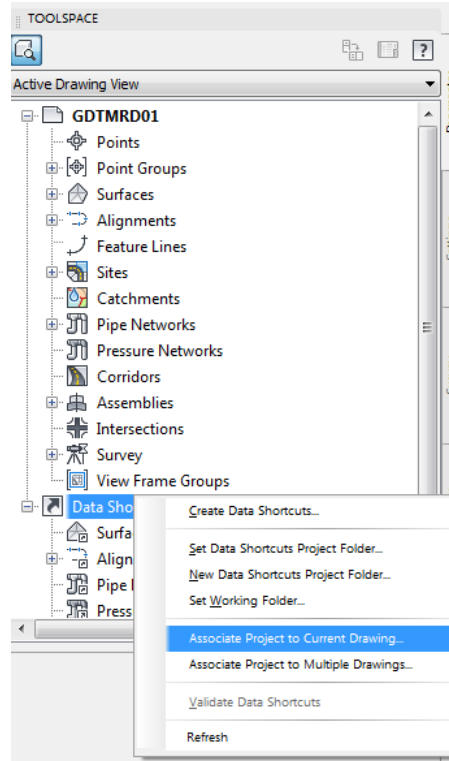

2. From the Associate Project to Current Drawing dialog, click OK

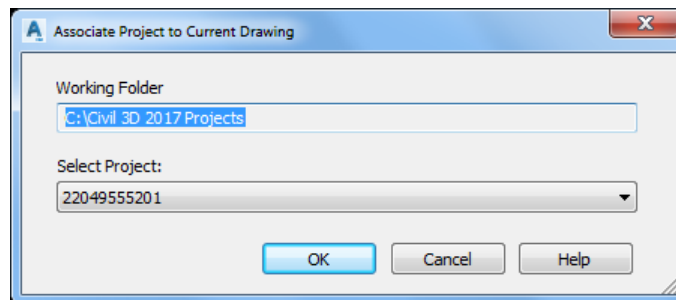

3. **Save** the GDTMRD01.dwg file

Exercise 4.4 Import LandXML File

In this exercise you will import an LandXML file, which contains a existing ground surface.

1. From the Insert Tab > Import Panel

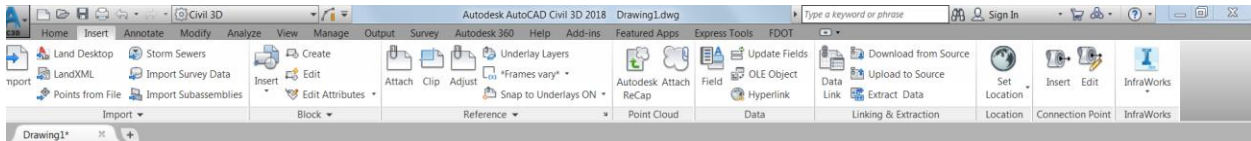

2. Select the LandXML icon

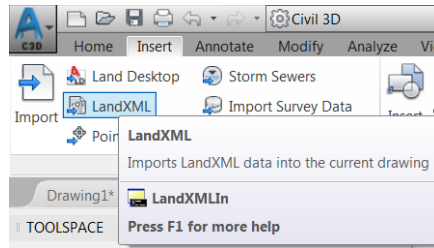

3. From the Import XML dialog, navigate to the C:\Civil 3D 2017 Projects\22049555201\Survey\XML folder, select the DTM Existing.XML file, Click Open, then Click OK to close the Import XML dialog.

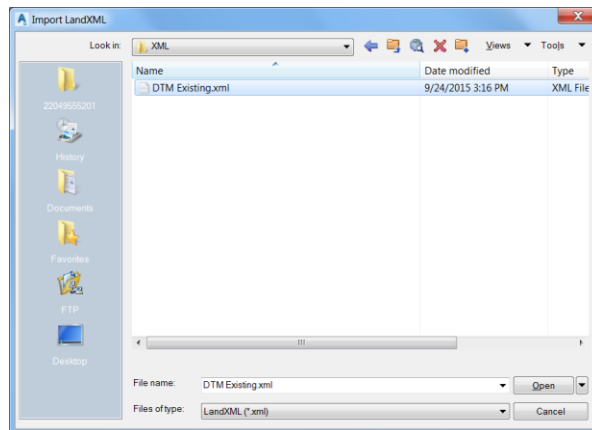

4. From the Import LandXML dialog Click OK to close the Import XML dialog.

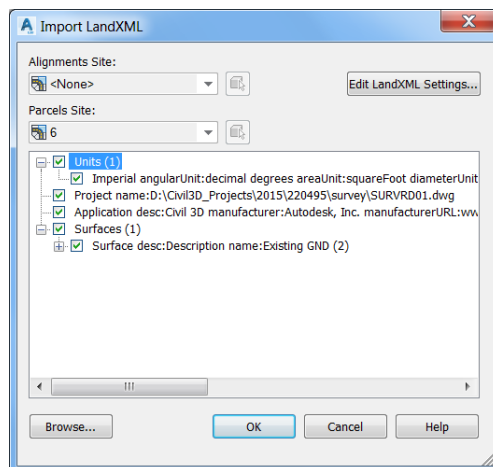

5. From the Event Viewer, Clear All Events, then Close the Event Viewer.

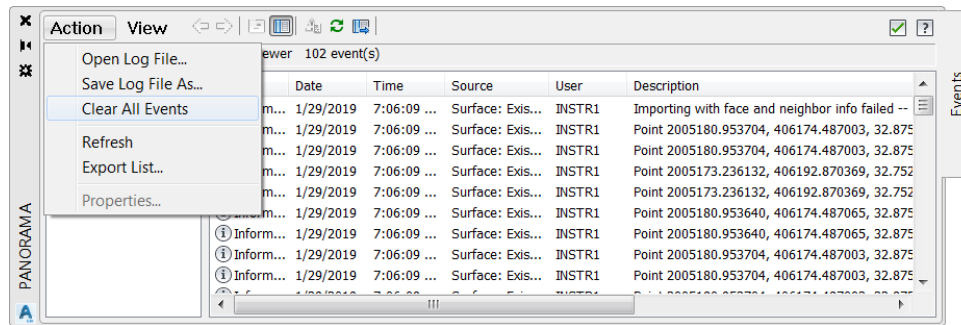

6. Perform a **Zoom Extents** to view results of the LandXML import.

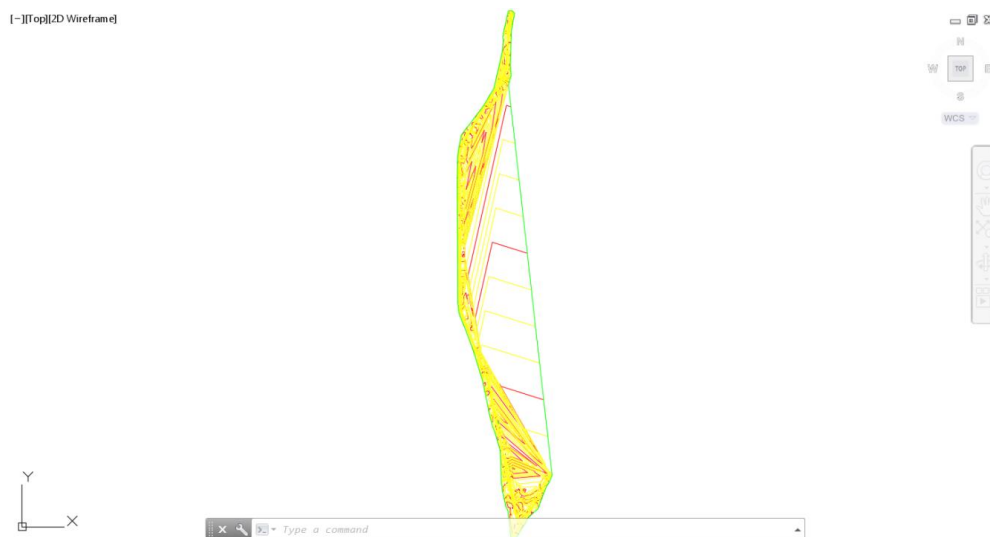

7. From the TOOLSPACE, Prospector tab, expand Surfaces collection. Right-Click on Existing GND, select Surface Properties...

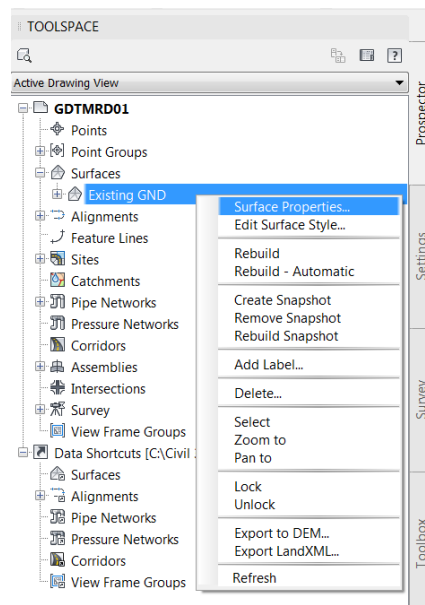

8. Rename Existing GND Surface to DTM Existing.
9. Set Surface style to Border-Existing [Green]

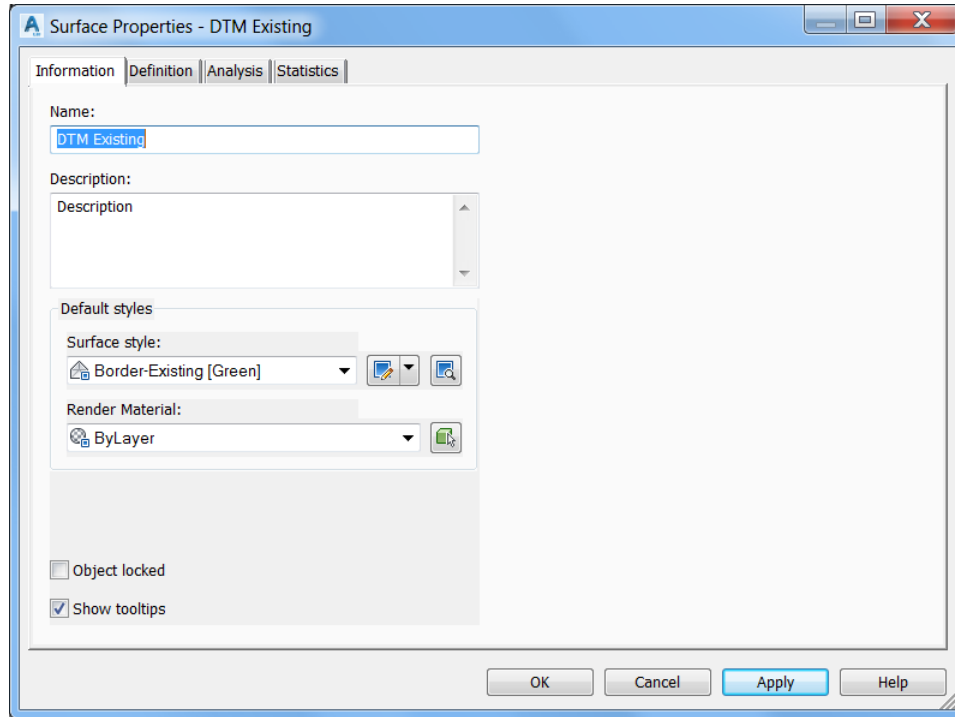

1. Click Apply then click OK to close Surface Properties - DTM Existing dialog
2. Review the results

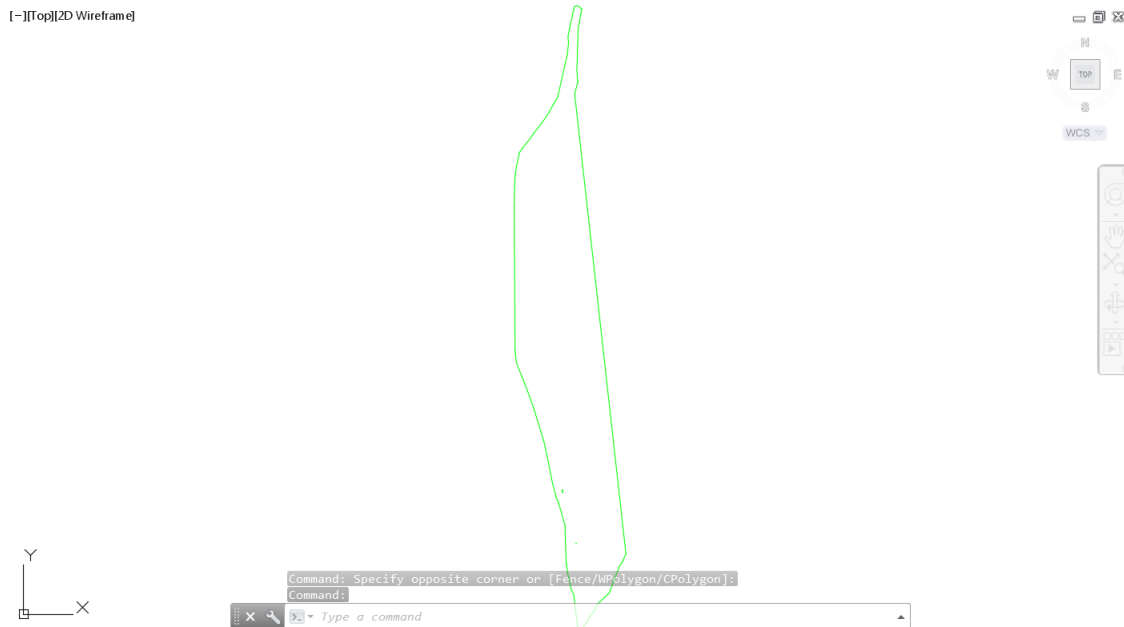

3. **Save** the GDTMRD01.dwg file

Exercise 4.5 *Insert block Surface Boundary.dwg*

In this exercise you will insert a block which will be used to define a surface boundary.

1. From the Insert Tab > Block Panel select the Insert command then select More options...

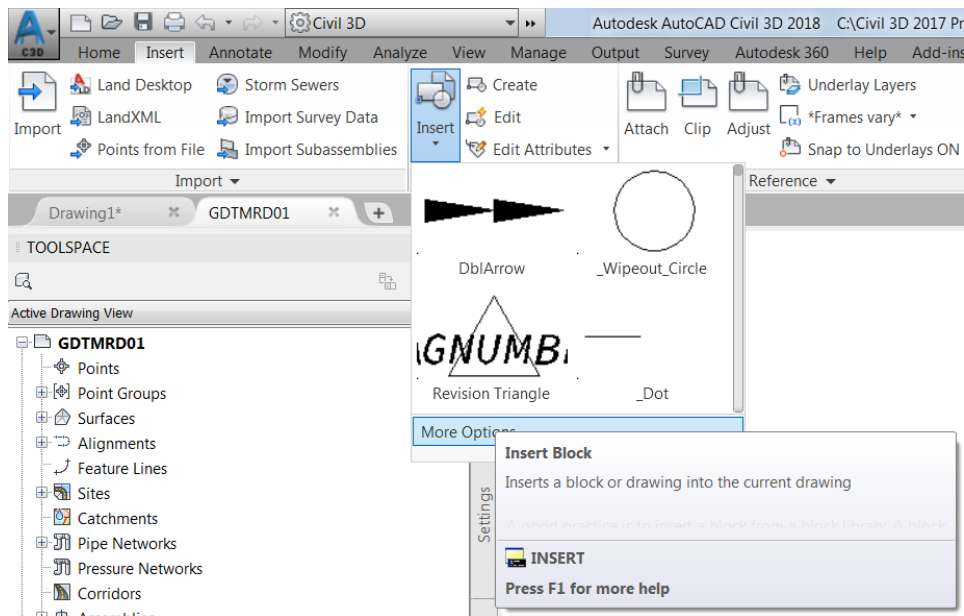
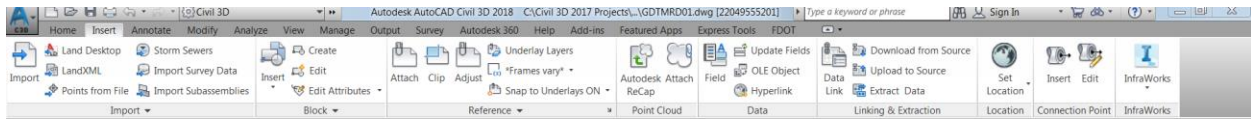

2. From the Insert dialog Click Browse

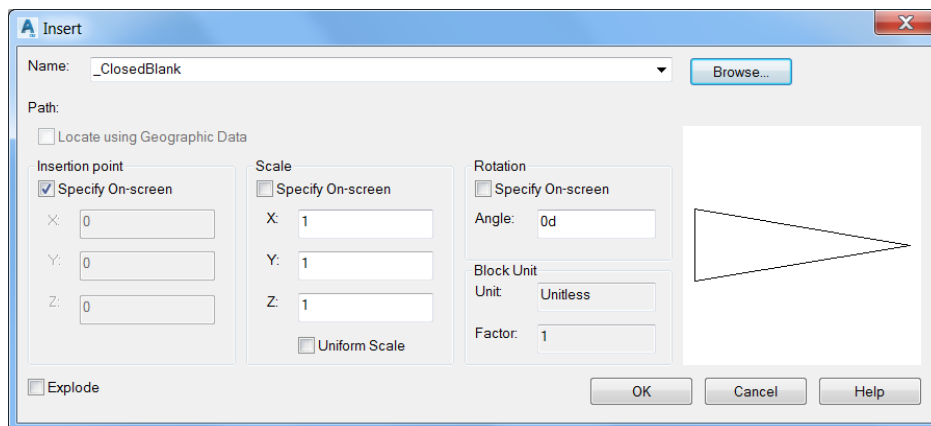

3. Navigate to the C:\Civil 3D 2017 Projects\22049555201\Survey folder , select the Surface Boundary.dwg, then Click Open.

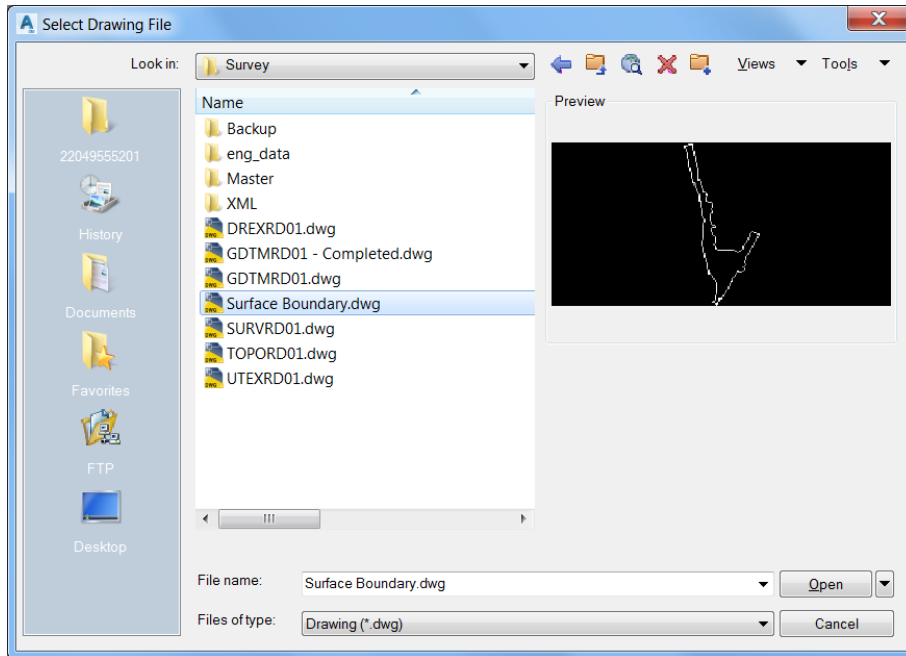

4. From the Insert dialog uncheck Insertion point, Scale, Rotation, then select Explode, and Click OK to close the Insert dialog.

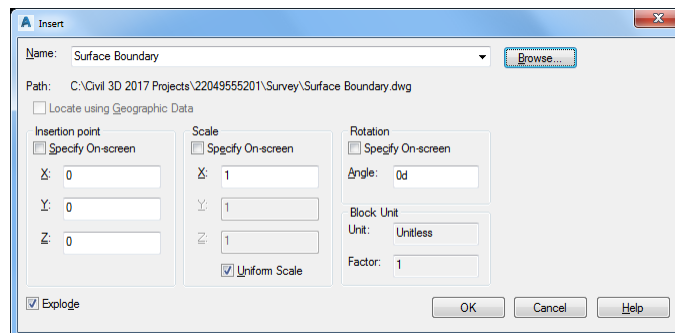

- 5. Perform a Zoom Window to review results of the block insertion.

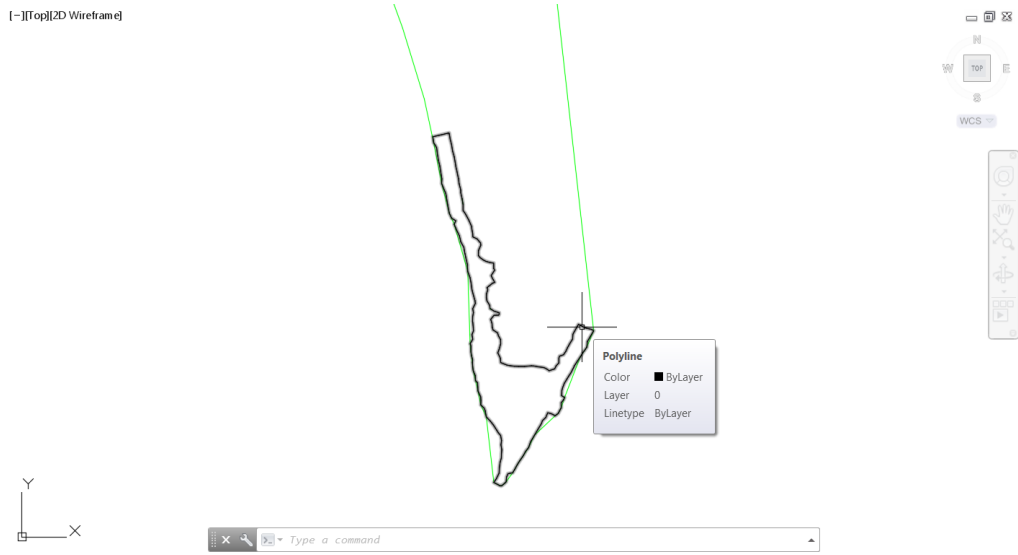

- 6. **Save** the GTDMRD01.dwg file

Exercise 4.6 Use Boundary Line work to create Surface Boundary:

In this exercise you will use the boundary linework from the prior exercise to create a surface boundary.

1. From the TOOLSPACE, Prospector tab, expand Surfaces collection.
2. Expand DTM Existing Surface, then expand Definition
3. Right-click on Boundaries, select ADD

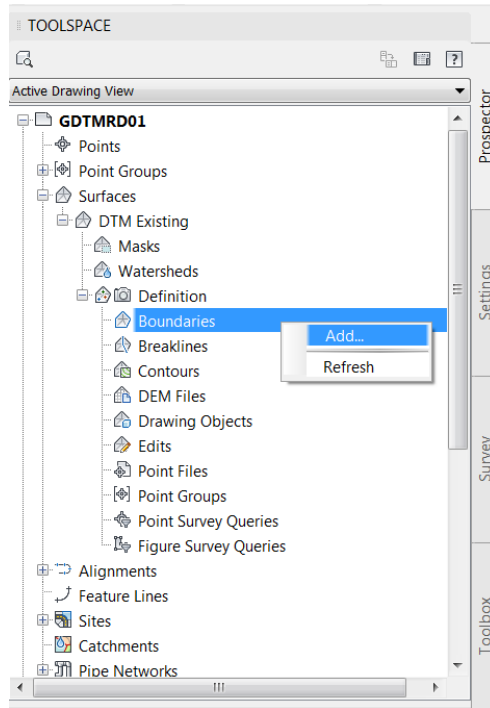

4. From the Add Boundaries dialog, for Name use DTM Existing, for Type use Outer, select Non-destructive breakline, set Mid-ordinate distance to 0.10', and then Click OK.

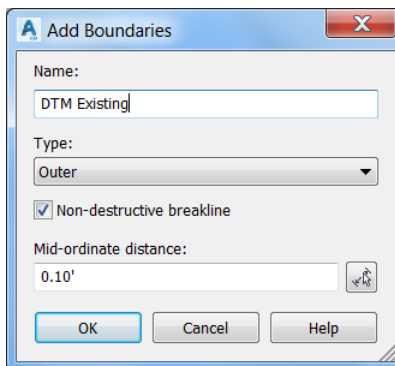

5. Select the white polyline that was created when you inserted the Surface Boundary.dwg block. From the Selection dialog select Polyline.

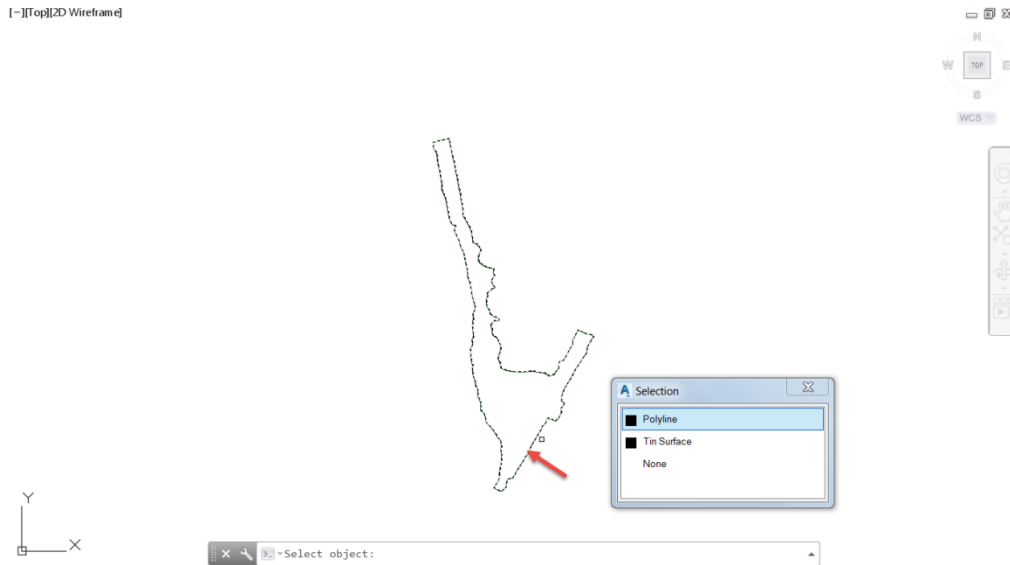

6. From the TOOLSPACE, Prospector tab, expand Surfaces collection.
7. Expand DTM Existing Surface, then expand Definition
8. Select Boundaries, in Item preview review DTM Existing listing.

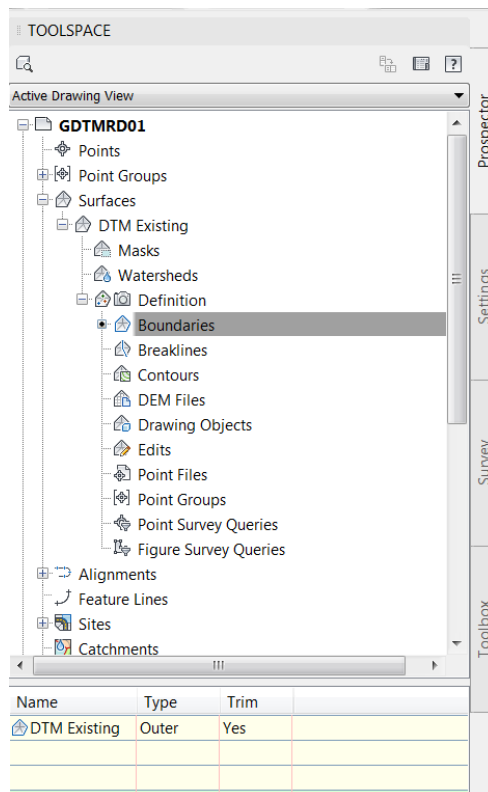

9. **Save** the GDTMRD01.dwg file.

Exercise 4.7 View Geolocation Maps for correct location:

In this exercise you will use a Geolocation Map to verify the project location.

1. From the Command line, type GEOMAP, select AERIAL option.



2. From the Geolocation - Online Map Data dialog, Click Yes

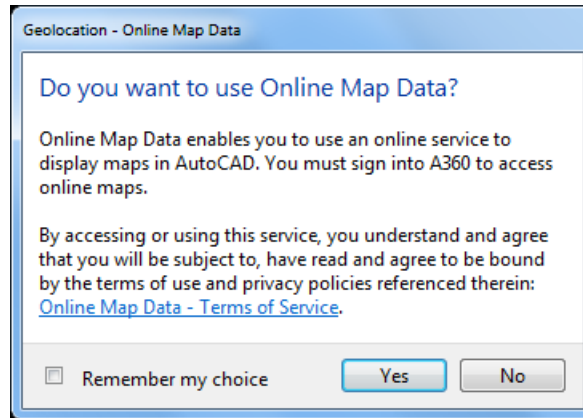

Note This exercise requires a A360 account. If you don't have an account you'll have to create one by clicking on CREATE ACCOUNT

3. From the Sign in dialog, type in your Email , Click NEXT

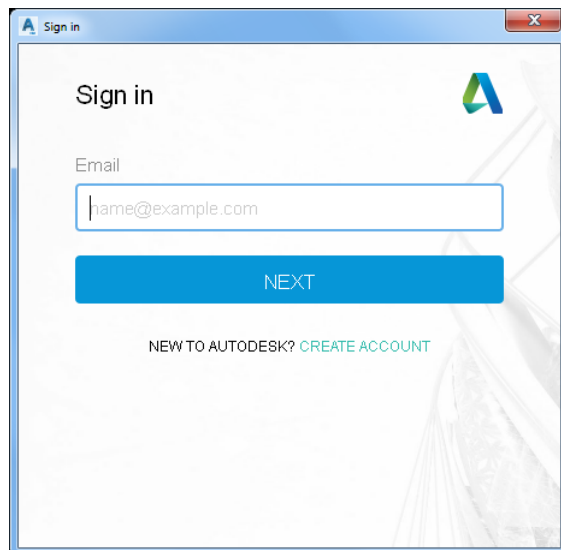

4. Type in your Password, then Click SIGN-IN

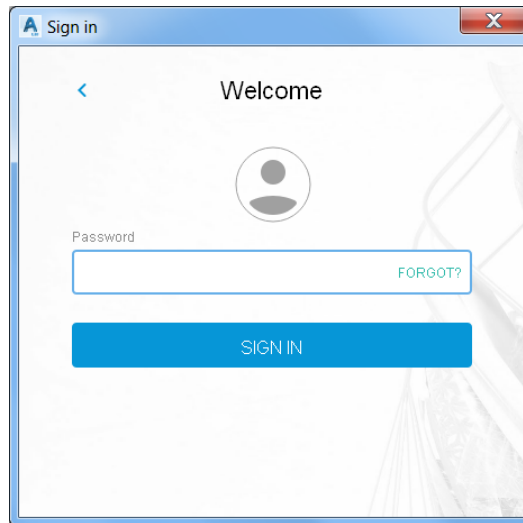

5. Review results:

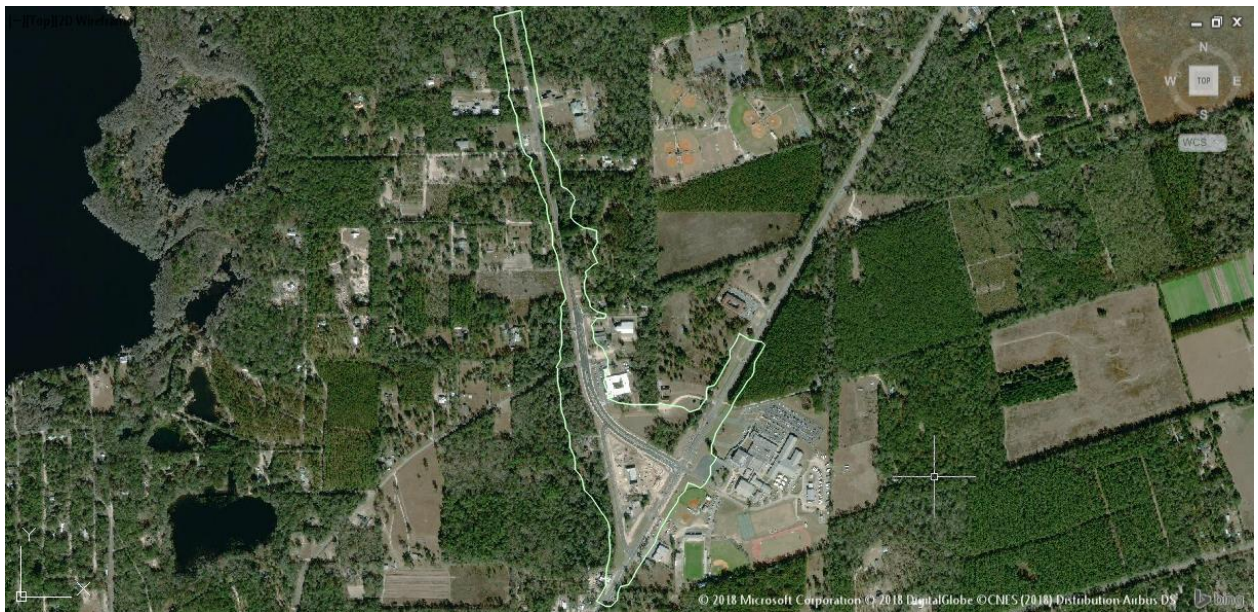

6. From the Command line, type GEOMAP, select OFF option.



[1]Top]2D Wireframe]

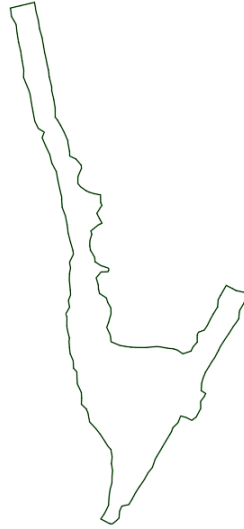

7. **Save** the GTDMRD01.dwg file

Exercise 4.8 Create Surface Data Shortcuts:

In this exercise you will create the GDTMRD01 file Data Shortcuts.

1. From the TOOLSPACE, Prospector tab, right-click on Data Shortcuts, then select Create Data Shortcuts.

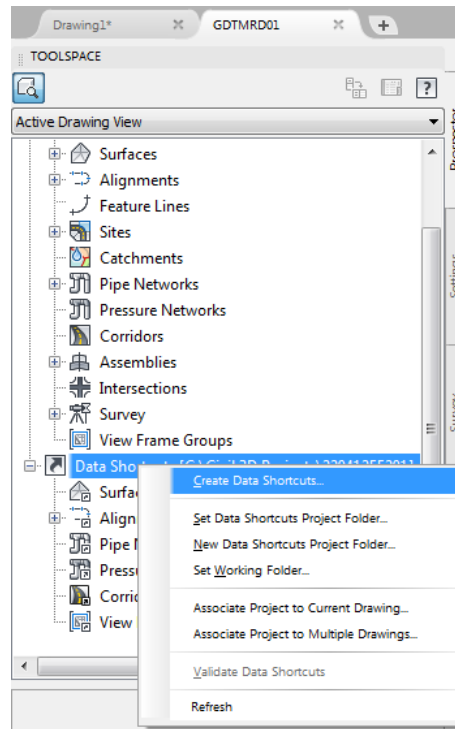

2. From the Create Data Shortcuts dialog, select Surfaces, then Click OK.

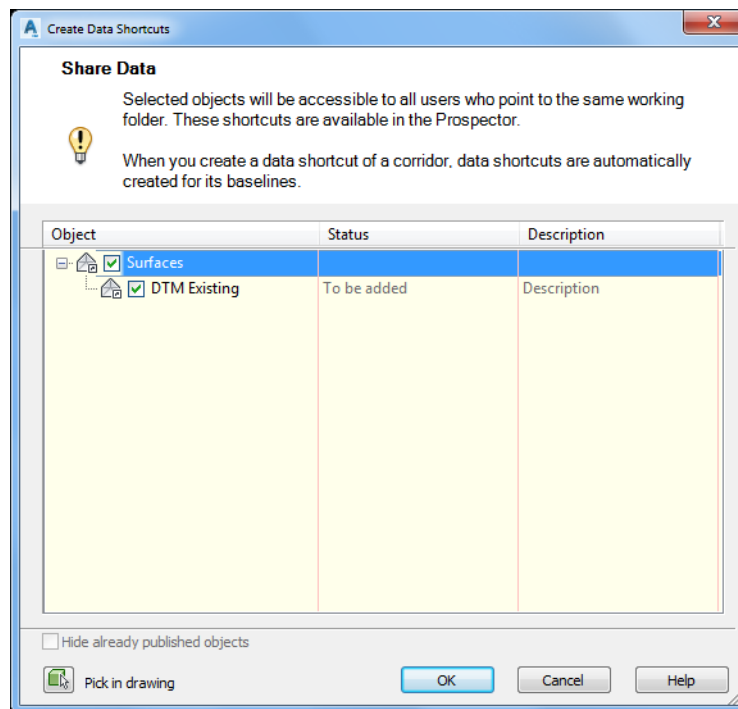

3. From the TOOLSPACE, Prospector tab, Expand Data Shortcuts, then expand the Surfaces collection.
4. Verify that the Surface DTM Existing is listed.

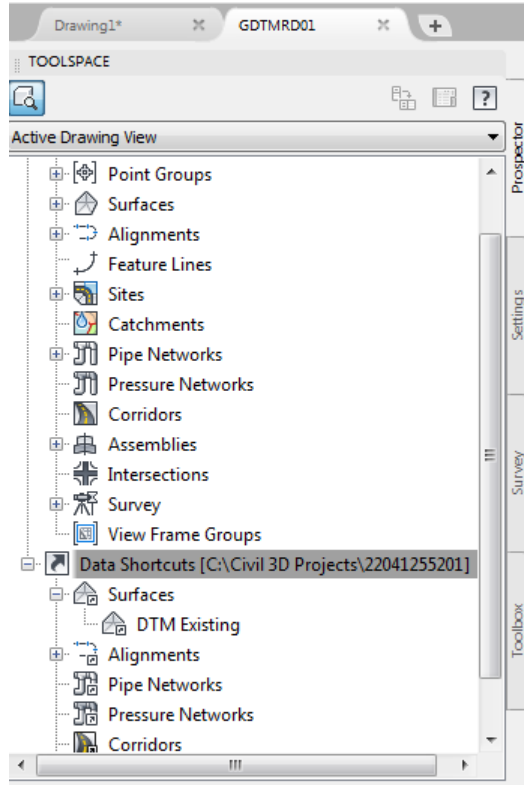

5. Perform a Zoom Window to display the DTM Existing Surface Boundary

[-][Top][2D Wireframe]



6. **Save** and **Close** the GDTMRD01.dwg file

5 Creating the ALGNRD01 File

DESCRIPTION

In this chapter you will open the ALGNRD01.dwg file already created to be used in the process of creating the SR61 Corridor model. Next you will import a LandXML file which contains a Alignment created by the Survey department. Then Data Shortcuts of the Alignment will be created.

OBJECTIVES

In this chapter, you will learn about:

- Import LandXML file
- Data Shortcuts
 - Set Working Folder
 - Set Data Shortcut Project Folder
 - Associate Project to Current Drawing
 - Creating Data References
- Creating Data Shortcuts
- Review Results

CHAPTER SETUP

Run the Chapter 5 - 22049555201.exe file and restore all files to the C:\Civil 3D 2017 Projects folder.

Do not change the location in which the Practice Files are installed. Doing so can cause errors when completing the exercises in this training manual.

Exercise 5.1 Set Data Shortcuts Paths

In this exercise you will set up the Data Shortcuts paths.

1. Start the FDOT Civil 3D State Kit by double clicking the **_FDOT2018.C3D** icon as shown below:



2. Set Data Shortcuts Paths for the 22049555201 project
3. From *TOOLSPACE* > *Prospector* tab > *Data Shortcuts*, right click to display popup menu and select **Set Working Folder**.

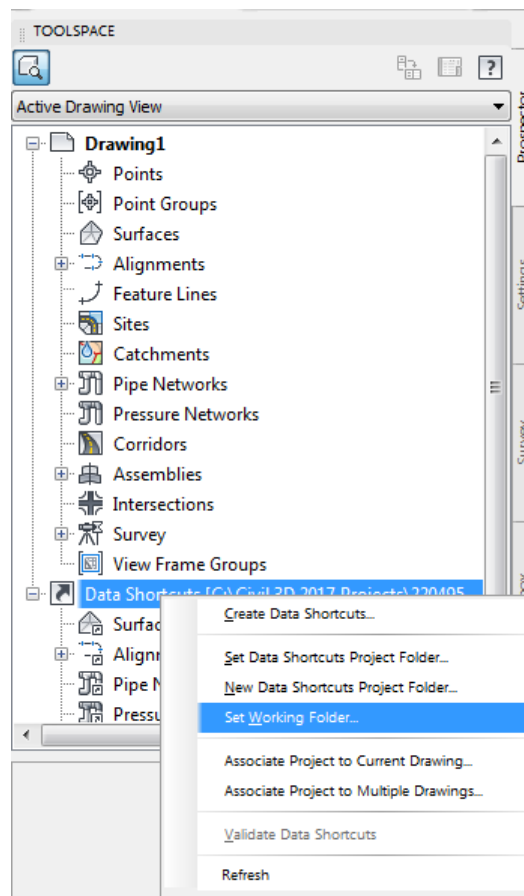

- From the Browse For Folder dialog box, use the scroll bar to navigate and click on the **C:\Civil 3D 2017 Projects** folder. Click **OK** to close the Browse For Folder dialog.

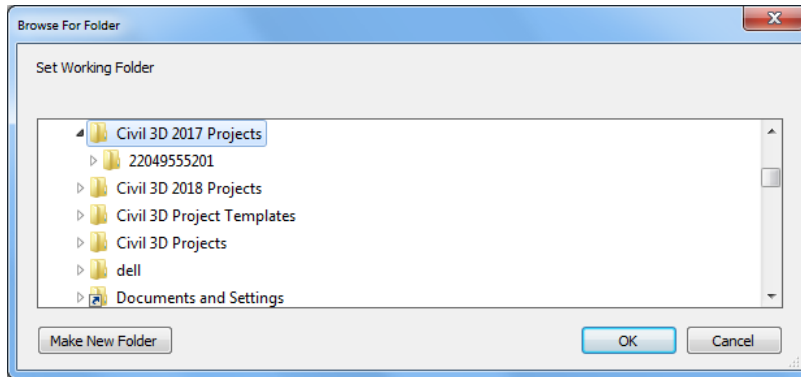

- From **TOOLSPACE > Prospector tab > Data Shortcuts**, right click and select **Set Data Shortcuts Project Folder**.

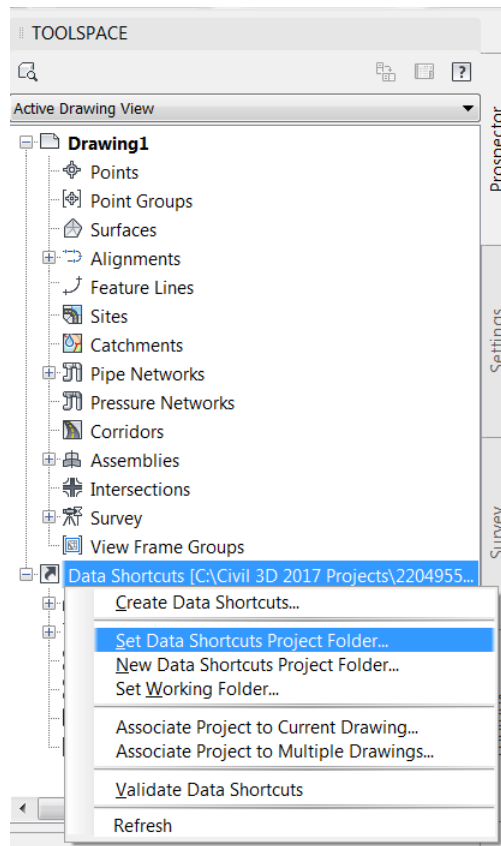

Exercise 5.3 *Open the ALGNRD01.DWG*

In this exercise you will open the ALGNRD01 file to verify the existing centerline alignments.

1. Open the ALGNRD01.DWG. From the Select File dialog box, navigate to the C:\Civil 3D 2017 Projects\22049555201\Roadway folder and select ALGNRD01.dwg Click Open to close the Select File dialog box.

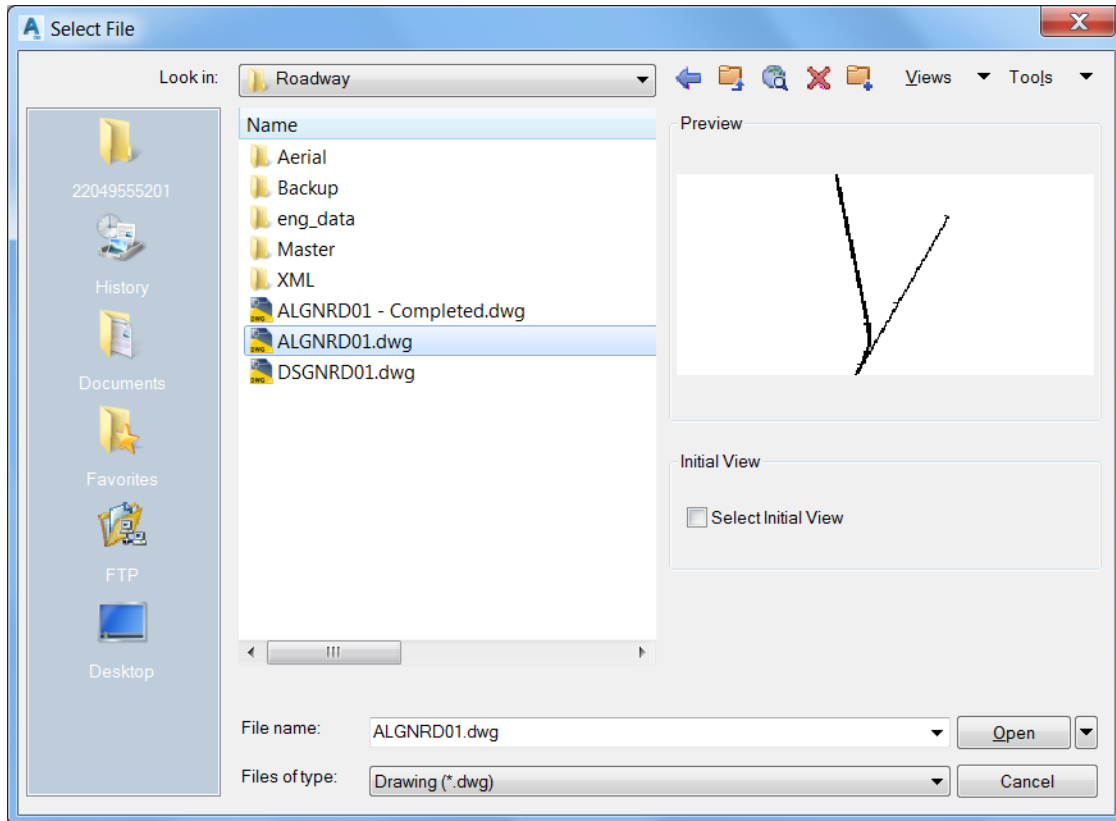

2. Hover over both Alignments to view Alignment names.

[-] [Top] [2D Wireframe]

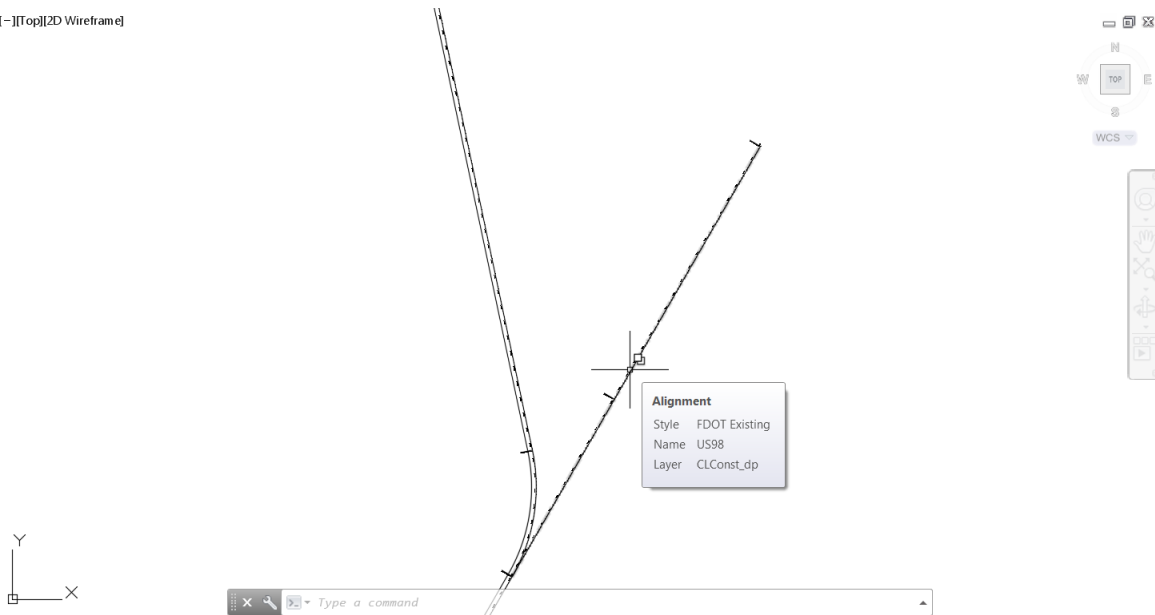

[-] [Top] [2D Wireframe]

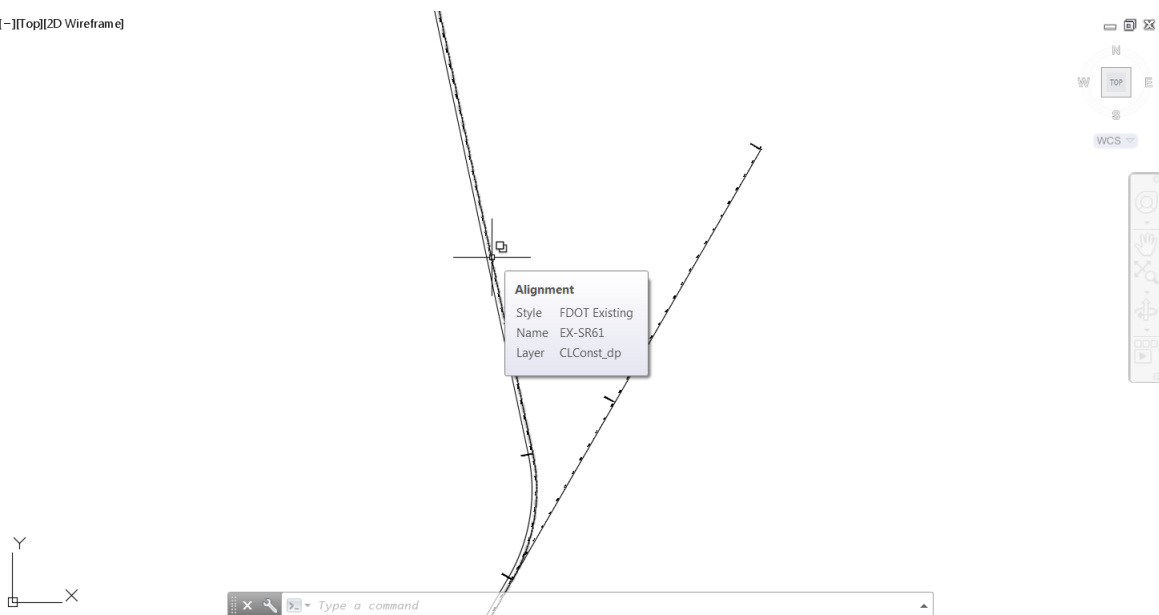

- From the TOOLSPACE, Prospector tab, expand Alignments collection, then expand Centerline Alignments

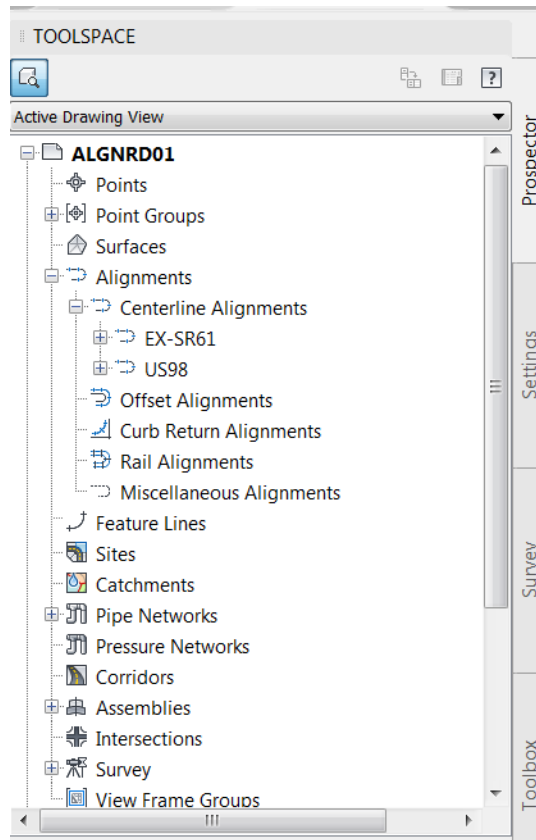

- Save** the ALGNRD01.dwg file

Exercise 5.4 Associate Project to Current Drawing

In this exercise you will associate the ALGNRD01 file to the current project.

1. From the TOOLSPACE, Prospector tab, right-click on Data Shortcuts, then select **Associate Project to Current Drawing**.

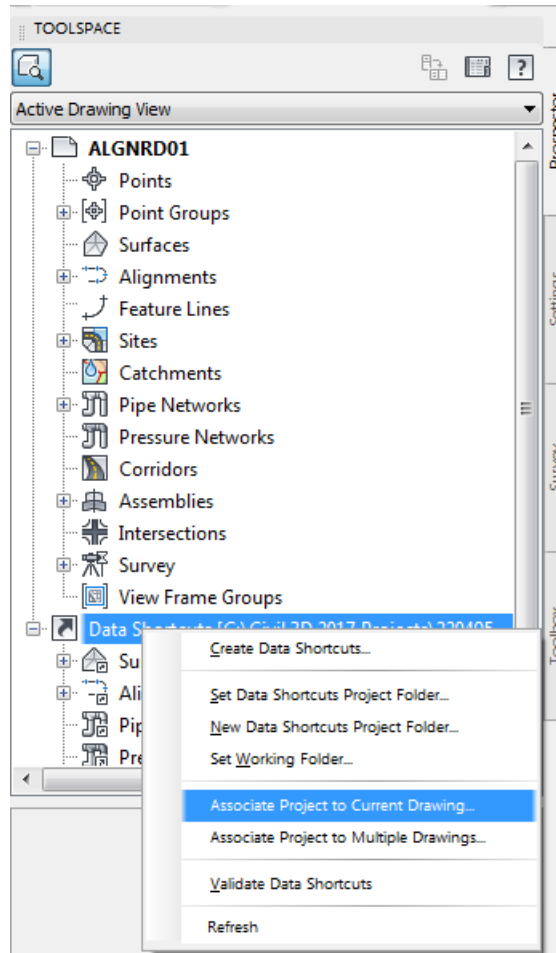

2. From the Associate Project to Current Drawing dialog, click OK.

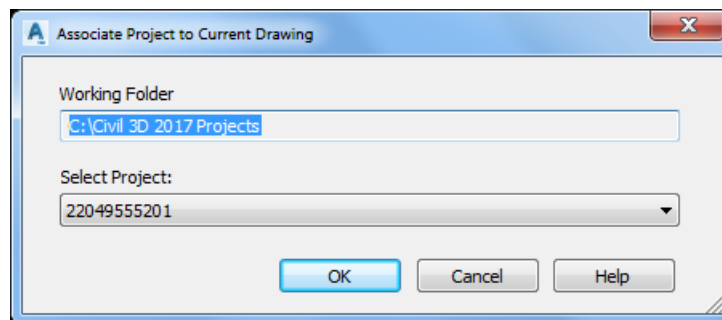

Exercise 5.5 Import Alignment from ALGNRD-SR61 LandXML file

In this exercise you will import an LandXML file, which contains the design alignment.

1. From the Insert Tab> Import Panel

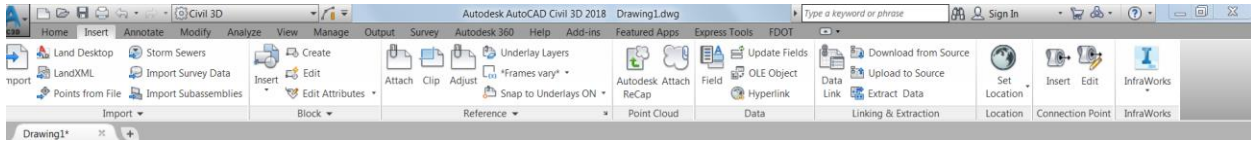

2. Select the LandXML icon

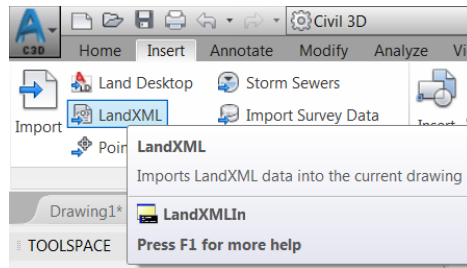

3. From the Import XML dialog, navigate to the C:\Civil 3D 2017 Projects\22049555201\Roadway\XML folder, select the ALGNRD-SR61.XML file, Click Open, then Click OK to close the Import XML dialog

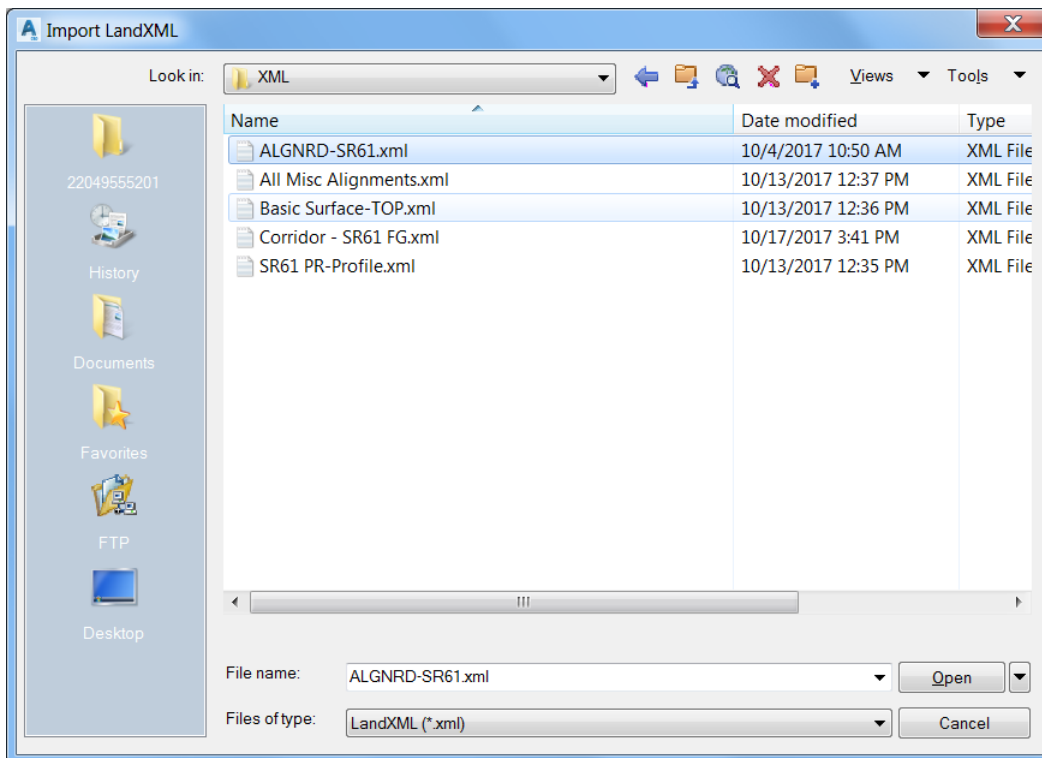

- From the Import LandXML dialog Click OK to close the Import XML dialog.

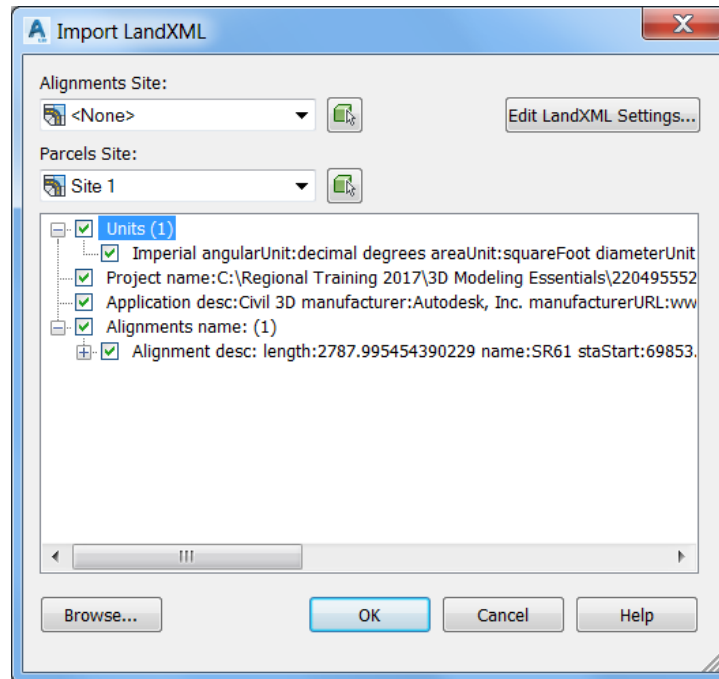

- From the Event Viewer, Clear All Events, then Close the Event Viewer.

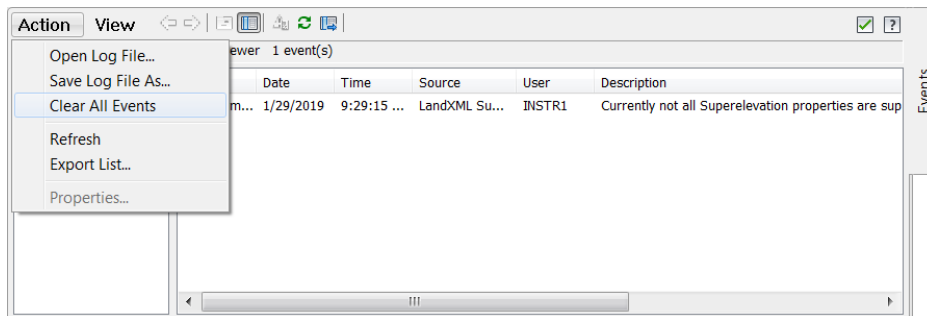

- Perform a Zoom Window to display the results of the LandXML Import. Hover over the LandXML imported Alignment.



- From the Toolspace, Prospector tab, expand the Alignments collection, then expand Centerline Alignments, Verify that the Name is SR61

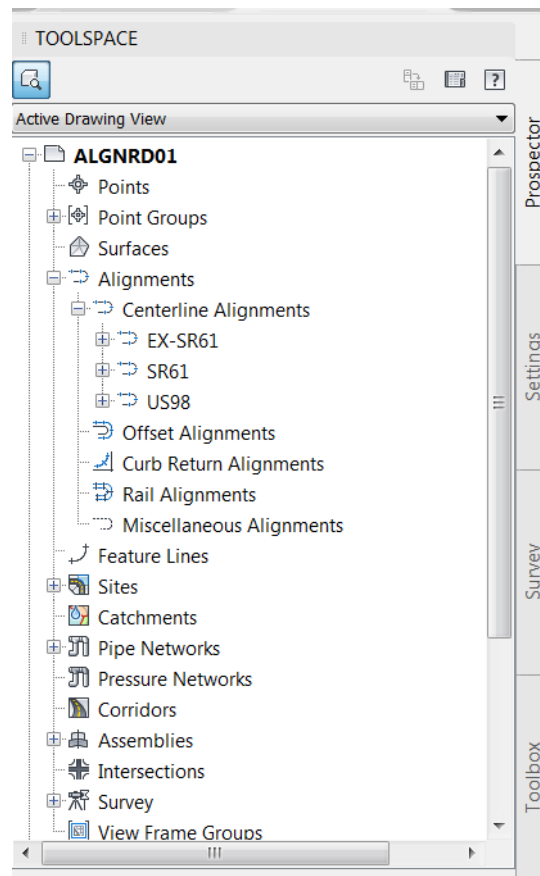

8. Right-click on SR61, then select Properties...

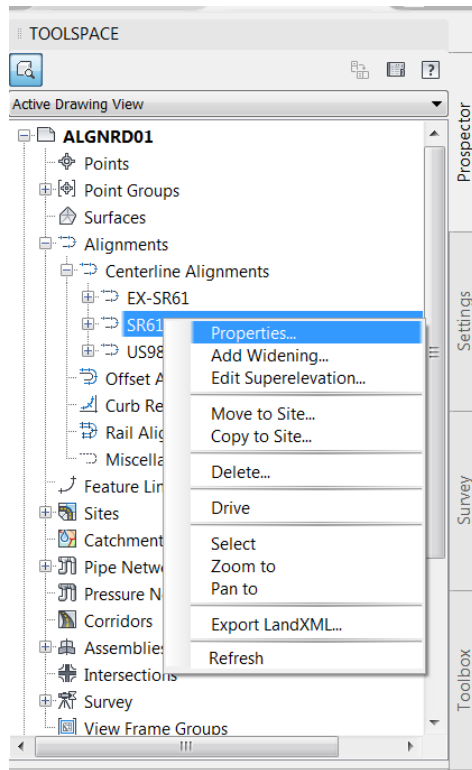

9. From the Alignment Properties - SR61 dialog select the Station Control Tab, verify that the Start Station is 698+53.79. Then Click OK to close the Alignment Properties - SR61 dialog.

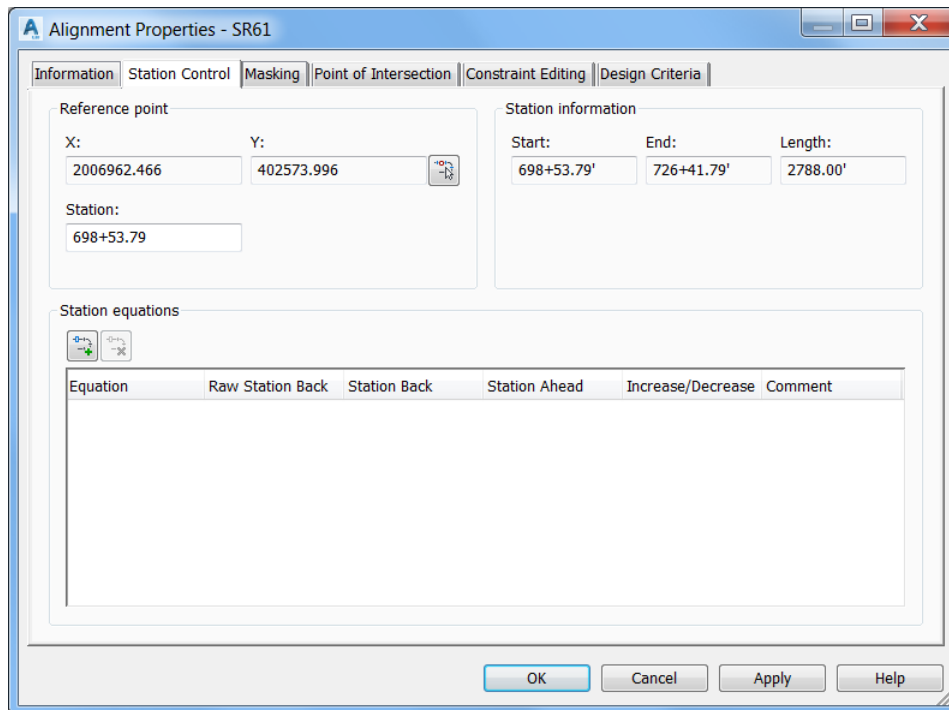

10. Perform a Zoom Window to display the Alignments Ex-SR61, SR61, and US98.



11. **Save** the ALGNRD01.dwg file

Exercise 5.6 Add Alignments to Data Shortcuts

In this exercise you will create the ALGNRD01 file Data Shortcuts.

1. From the TOOLSPACE, Prospector tab, right-click on Data Shortcuts, then select Create Data Shortcuts.

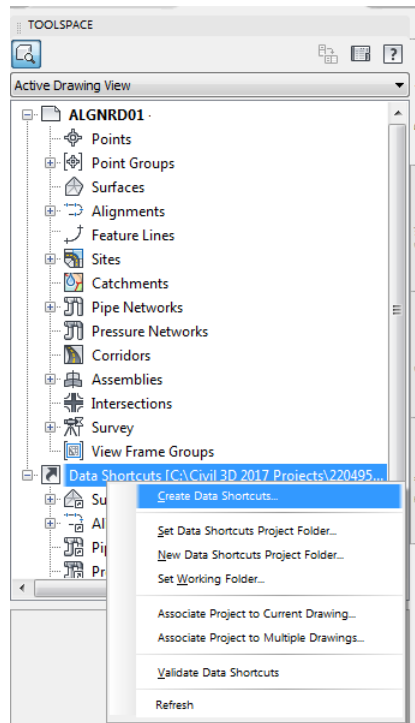

2. From the Create Data Shortcuts dialog, select Alignments, then Click OK.

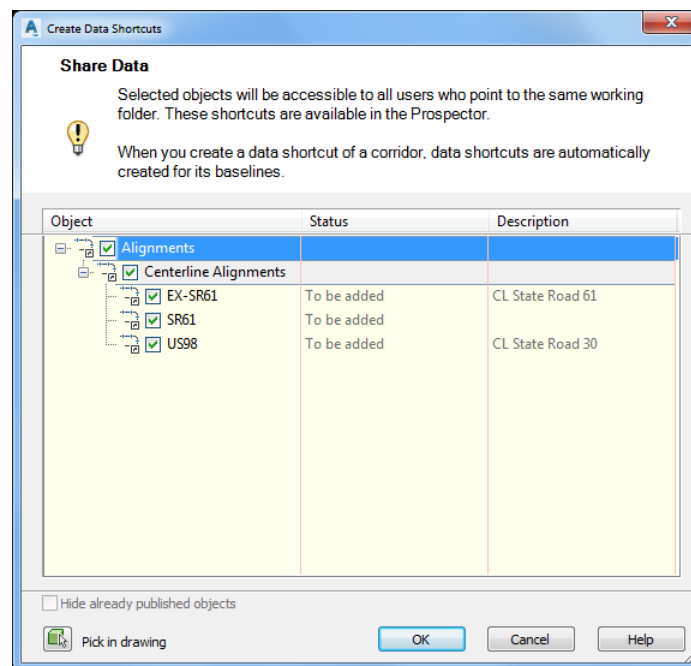

3. From the TOOLSPACE, Prospector tab, Expand Data Shortcuts, then expand the Alignments collection, then expand Centerline Alignments.
4. Verify that the EX-SR61, SR61, and US98_Centerline Alignments are listed.

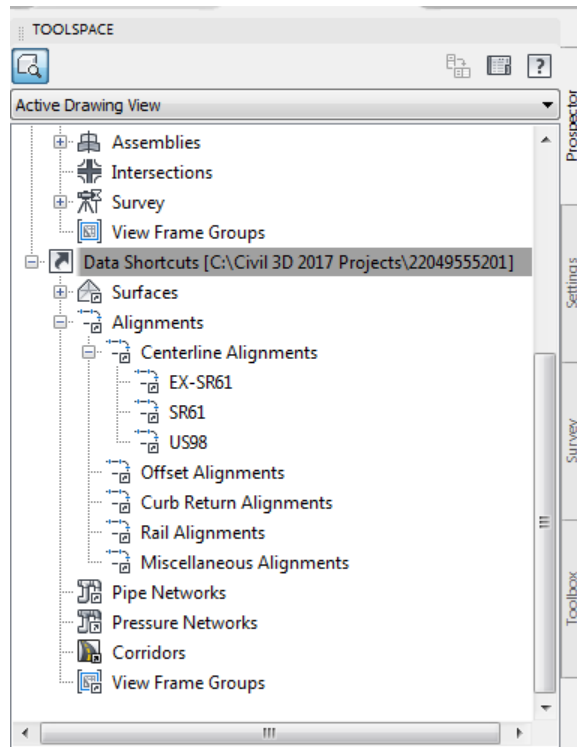

5. Perform a Zoom Window to display the Alignments Ex-SR61, SR61, and US98.

[Top] 2D Wireframe

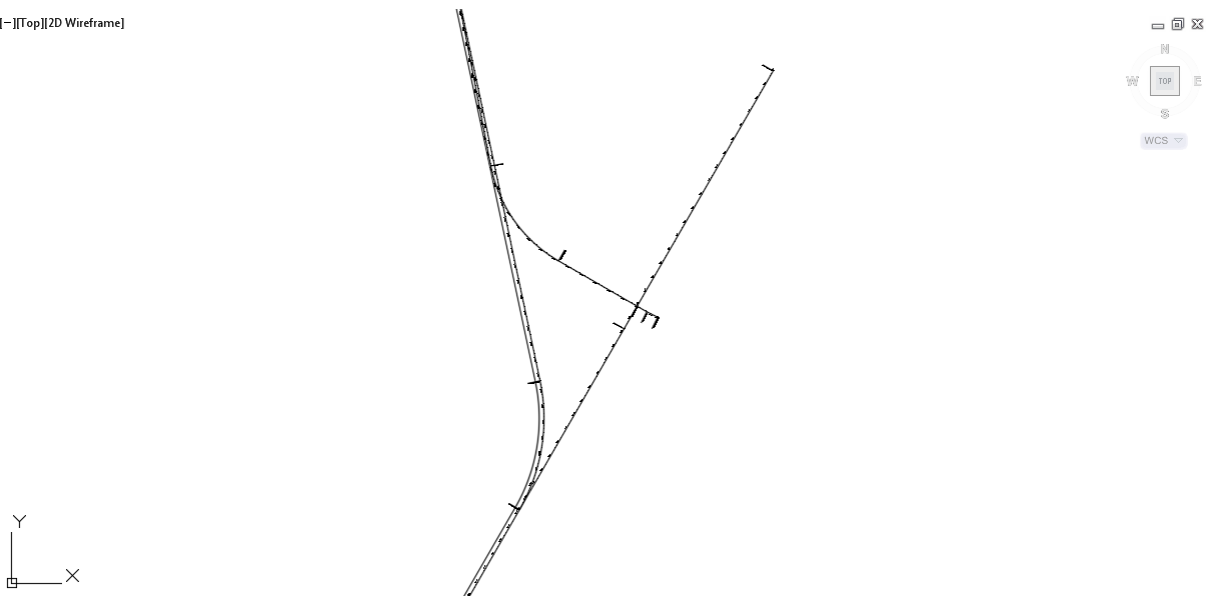

6. **Save** and **Close** the ALGNRD01.dwg file

[PAGE INTENTIONALLY LEFT BLANK]

6 Creating the MODLRD01-Existing Conditions Corridor

DESCRIPTION

In this Chapter you will create the MODLRD01- Existing Conditions.dwg file, Next, you'll follow the FDOT workflows to create the MODLRD01- Existing Conditions Corridor model for SR61, Then you'll create Sample lines and Section views for the MODLRD01- Existing Conditions Corridor model for SR61.

OBJECTIVES

In this chapter, you will learn about:

- FDOT Existing Feature Assembly
- Setup Data Shortcuts
- Toggle Selection Cycling On
- Create MODLRD01-Existing Corridor file
- Associate Project to Current Drawing
- Attach External Reference files
- Create Data Shortcut References for Surfaces and Alignments
- Create Existing Surface Profile
- Create Assembly
- Create Existing Conditions Corridor
- Create Sample Lines
- Create Cross Sections
- Highlight Corridor Regions in Corridor Properties and see the Region highlighted in drawing editor
- Review

CHAPTER SETUP

Run the Chapter 6 - 22049555201.exe file and restore all files to the C:\Civil 3D 2017 Projects folder.

Do not change the location in which the Practice Files are installed. Doing so can cause errors when completing the exercises in this training manual.

Note Some of the content in this chapter is from the FDOT Subassemblies Help file.

OVERVIEW OF THE FDOT EXISTING FEATURES ASSEMBLY

In this chapter you'll review the features of the FDOT Existing Features Assembly found in the FDOT Subassemblies tool palette > Assemblies Tab.

1. From the Home Tab > Palettes Panel, select Tool Palettes.

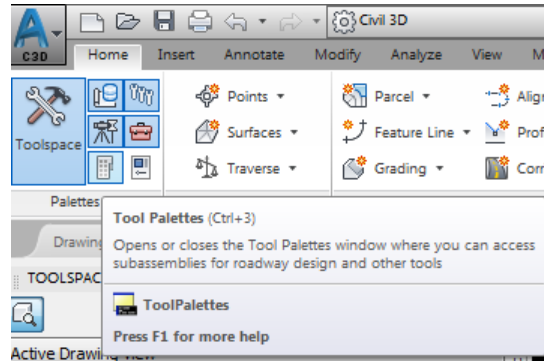

2. Right-click on the Tool Palette title bar, select FDOT Subassemblies, then select the Assemblies Tab.

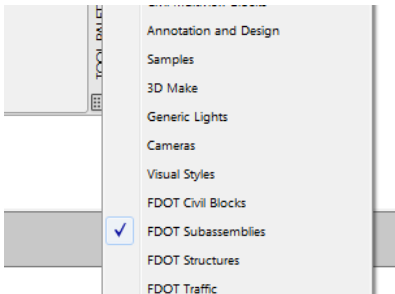

3. Right-click on the FDOT Existing Features assembly, then select Help... to open the FDOT Subassemblies help file.

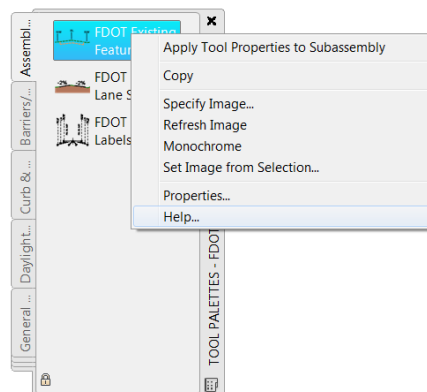

- Now you can review the features of the FDOT Existing Features Assembly from the FDOT Subassemblies Help file.

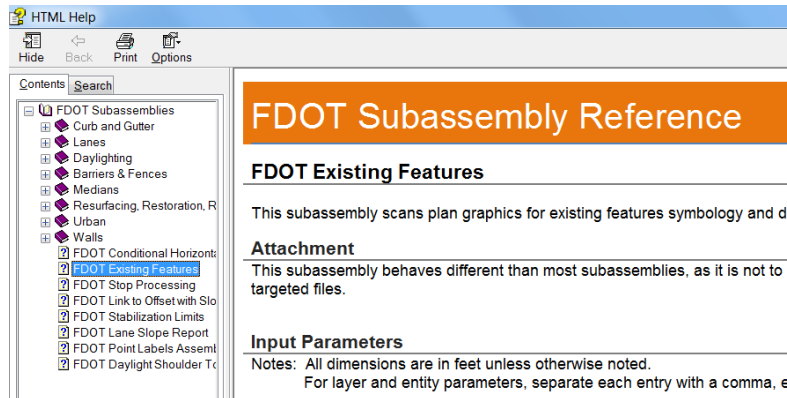

FDOT EXISTING FEATURES ASSEMBLY

This subassembly scans plan graphics for existing features symbology and draws the feature at each corridor station. This subassembly also may be used to draw Typical Right of Way Section features.

ATTACHMENT

This subassembly behaves different than most subassemblies, as it is not to be connected to other subassemblies. Rather, the subassembly creates points and links based off of symbology found in the targeted files.

INPUT PARAMETERS

Notes: All dimensions are in feet unless otherwise noted.

For layer and entity parameters, separate each entry with a comma, enter "none" or leave entry blank for the layer specification to not process a specific feature.

Parameter	Description	Type	Default
Draw ROW Features	This parameter controls whether or not multiple features that are processed. These features are identified as such throughout the table below.	True/False	True
Search Xrefs	Specifies whether or not Xrefs are searched for existing feature entities.	True/False	True
Use entity to limit search distance	Limits the search distance of an entity. This overrides the left/right search distance parameters as long as the limiting entity is within the "Left Search Distance" and "Right Search Distance". This can be used for special areas in the corridor so that the station data does not have to be overridden.	True/False	True
Curb-Gutter Search Distance	Specifies the distance to search for Back of Curb to connector entity.	Double, Positive	3.00'
Curb-Gutter Thickness	Specifies the thickness of existing gutter at the flange. Set this value to zero to not process sidewalk features.	Double, non-Negative	0.67'
Existing Pavement Search Distance	Specifies the distance to search from current pavement entity for a matching pavement entity.	Double, Positive	24.00'
Existing Pavement Thickness	Specifies the thickness of the existing pavement.	Double, Positive	0.67'
Left Search Distance	Specifies the distance to search for entities to the left of the Alignment.	Double, Positive	100.00'
Misc. Pavement Search Distance	Specifies the distance to search for the existing misc. pavement entity.	Double, non-Negative	12.00'
Misc. Pavement Thickness	Specifies the thickness of the existing misc. pavement. Set this value to zero to not process misc. pavement features.	Double, non-Negative	0.33'
Right Search Distance	Specifies the distance to search for entities to the right of the Alignment	Double, Positive	100.00'
Shoulder Search Distance	Specifies the distance to search from current shoulder entity for the matching shoulder connector entity	Double, Positive	15.0.00'
Shoulder Thickness	Specifies the thickness of existing shoulder. Set to this value to zero to not process shoulder features.	Double, non-Negative	0.50'
Sidewalk Search Distance	Specifies the distance to search sidewalk entity to matching sidewalk connector entity.	Double, Positive	10.00'
Minimum Sidewalk Search Distance	Specifies the minimum distance to search sidewalk entity to matching sidewalk connector entity.	Double, Positive	1.00'
Sidewalk Thickness	Specifies the thickness of existing sidewalk. Set this value to zero to not process sidewalk features.	Double, non-Negative	0.33'
Traffic Separator Thickness	Specifies the thickness of traffic separator at its face. Set this value to zero to not process traffic separators features.	Double, non-Negative	0.67'
Height or Cross Section Line	This parameter is a Draw ROW Feature. The height of the line that denotes the feature below in cross section. Set this value to 0 (zero) to suppress lines in cross section.	Double	10.00'
Offset or Cross Section Line	This parameter is a Draw ROW Feature. The offset of the line that denotes the feature below from the surface, this input can be used to move the Section Line up/down in cross section	Double	1
Baseline Survey Line Layer	This parameter is a Draw ROW Feature. Specifies the layer for the Baseline Survey Line.	String	BaselineSurvey
Curb-Gutter Back Search Layers	Specifies the layer for the Existing Back of Curb Entities.	String	CGBack_ep
Centerline Layer	This parameter is a Draw ROW Feature. Specifies the layer for the Major Centerline Line.	String	CLMajor
Curb-Gutter Connector Search Layers	Specifies the layers for entities that Back of Curb will try to connect to. When entering multiple layer names, separate them with a comma with no spaces.	String	TopoMisc_ep PavtAsph_ep PavtConc_ep PavtMisc_ep SidewalkFront_ep SidewalkBack_ep Driveway_ep ShldrPaved_ep
Existing EOP Search Layer	Specifies the layers for Existing Pavement entities. When entering multiple layer names, separate them with a comma with no spaces.	String	PavtAsph_ep PavtConc_ep
Existing Fence Line Layer	Specifies the layers for Existing Fence entities. When entering multiple layer names, separate them with a comma with no spaces.	String	Fence_ep

Existing Easement Line Layer	This parameter is a Draw ROW Feature. Specifies the layer for the Existing Easement Line.	String	EaseLine_ep
Existing Property Line Layer	This parameter is a Draw ROW Feature. Specifies the layer for the Existing Property Line.	String	PropertyLine_ep
Existing Right of Way Limited Access Line Layer	This parameter is a Draw ROW Feature. Specifies the layer for the Existing Limited Access Right of Way Line.	String	LARWLine_ep
Existing Right of Way Line Layer	This parameter is a Draw ROW Feature. Specifies the layer for the Existing Right Of Way Line.	String	RWLine_ep
Existing Wetland Line Layer	This parameter is a Draw ROW Feature. Specifies the layer for the Existing Wetlands Line.	String	Wetland_ep
Guardrail Search Layer	Specifies the layers for existing Guardrail entities. When entering multiple layer names, separate them with a comma with no spaces.	String	GuardrailDbL_ep GuardrailLt_ep GuardrailRt_ep
License Agreement Line Layer	This parameter is a Draw ROW Feature. Specifies the layer for the Easement License Agreement Line.	String	EaseLicLine
Misc. Pavement Search Layers	Specifies the layer for the Existing Misc. Pavement entities.	String	TopoMisc_ep
PGL Left Line Layer	This parameter is a Draw ROW Feature. Specifies the layer for the PGL Left Line.	String	GradelineLt_dp
PGL Right Line Layer	This parameter is a Draw ROW Feature. Specifies the layer for the PGL Right Line.	String	GradelineRt_dp
Fence Line Layer	This parameter is a Draw ROW Feature. Specifies the layer for the Proposed Fence Line.	String	Fence
Proposed Perpetual Easement Line Layer	This parameter is a Draw ROW Feature. Specifies the layer for the Proposed Perpetual Easement Line.	String	EasePerpLine
Proposed Right of Way Limited Access Line Layer	This parameter is a Draw ROW Feature. Specifies the layer for the Proposed Limited Access Right of Way Line.	String	LARWLine
Proposed Right of Way Line Layer	This parameter is a Draw ROW Feature. Specifies the layer for the Proposed Right of Way Line.	String	RWLine
Proposed Temporary Easement Line Layer	This parameter is a Draw ROW Feature. Specifies the layer for the Proposed Temporary Easement Line	String	EaseTempLine
Entity Types to include in search parameters	Specifies the types of AutoCAD/Civil3D entities to include in the search parameters. When entering multiple layer names, separate them with a comma with no spaces.	String	LINE ARC LWPOLYLINE POLYLINE AECC_SVFIGURE
Layer for Search Limit Entity	Specifies the layer on which the Limit Search entity is located. The entity type is set in the "Entity Types to include in search parameters" parameter.	String	SearchLimits
Shoulder Search Layers	Specifies the layer for the Existing Shoulder entities.	String	ShldrPaved_ep
Sidewalk Back Search Layers	Specifies the layer for the Existing Back of Sidewalk entities.	String	SidewalkBack_ep
Sidewalk Connector Search Layers	Specifies the layers for entities that Back of Sidewalk will try to connect to. When entering multiple layer names, separate them with a comma with no spaces.	String	CGBack_ep Building_ep
Sidewalk Front Search Layers	Specifies the layer for Existing Front of Sidewalk entities.	String	SidewalkFront_ep
Traffic Separator Search Layers	Specifies the layer for existing Traffic Separator entities.	String	TrafSeparator_ep

TARGET PARAMETERS

This section lists the parameters in this subassembly that can be mapped to one or more target objects, such as a surface, alignment, or profile object in a drawing. For more information, see *Setting Targets in the AutoCAD Civil 3D User’s Guide Help*.

Parameter	Description	Status
Surface	Specify the surface that existing features will use for connection	required

OUTPUT PARAMETERS

Parameter	Description	Type
None		

BEHAVIOR

This subassembly searches a set width at each corridor station for intersecting plan graphics. It then draws existing features that connect to the defined surface.

ASSUMPTIONS:PAVEMENT:

There must be an even number of pavement points found for subassembly to run. All processing stops if at least one matching pair of pavement points are not found. (If an odd number of points are encountered, an entry is created in the Civil3D event viewer labeling the station and number of points found).

TRAFFIC SEPARATORS:

Only appear between pavement structures.

Traffic separator points appearing within a pavement structure are marked as errors.

SHOULDER:

Only one shoulder can exist left of left most pavement structure (if more than 1 is found, only the shoulder point closest to pavement is processed).

Only one shoulder can exist right of right most pavement structure (if more than 1 is found, only the shoulder point closest to pavement is processed).

A maximum of 2 shoulder points are processed between pavement structures. The left most shoulder point connecting to the leftmost pavement structure, the right most shoulder point connects to the rightmost pavement structure, all others marked as errors.

Shoulder points connect to the closest pavement structure except if Shoulder note 3 above is encountered.

Shoulder points existing within a pavement structure are marked as errors.

GUARDRAIL:

Guardrail points appearing within a pavement structure are marked as errors.

Left, Right, and Double guardrail are delineated by a substring of the layer name by

“LT_” : left

“RT_” : right

“DBL_” : double

BACK OF CURB:

Connects to closet curb connector entity within search distance.

Curb points existing within a pavement structure are marked as errors.

SIDEWALK:

Back of Sidewalk point first looks for closest Front of Sidewalk point within search distance (front of sidewalks points removed from further search effort at current station).

Back of Sidewalk then looks for closest connector point with search distance and greater than minimum search distance.

Remaining Front of Sidewalk points connect to remaining Front of Sidewalk points within search distance.

LAYOUT MODE OPERATION

In layout mode, this subassembly only draws a horizontal line

POINT, LINK, AND SHAPE CODES

The following lists the point, link, and shape codes for this subassembly that have codes assigned to them. Point, link, or shape codes for this subassembly that do not have codes assigned are not included in this list.

This subassembly adds point and link codes as needed to represent sub-surface existing features.

Point Code “Error” will be entered at existing feature points that fail connection criteria.

The following link codes will be added when the appropriate criteria is met:

ExistingPavement

ExistingTrafficSeparator

ExistingMiscPavement

ExistingCurbAndGutter

ExistingSidewalk

ExistingShoulder

CODING DIAGRAM

No coding diagram for this subassembly. Coding is generated by existing features found.

Exercise 6.1 Set Data Shortcuts Paths

In this exercise you will set up the Data Shortcuts paths.

1. Start the FDOT Civil 3D State Kit by double clicking the **_FDOT2018.C3D** icon as shown below:



2. Set Data Shortcuts Paths for the 22049555201 project
3. From *TOOLSPACE* > *Prospector* tab > *Data Shortcuts*, right click to display popup menu and select **Set Working Folder**.

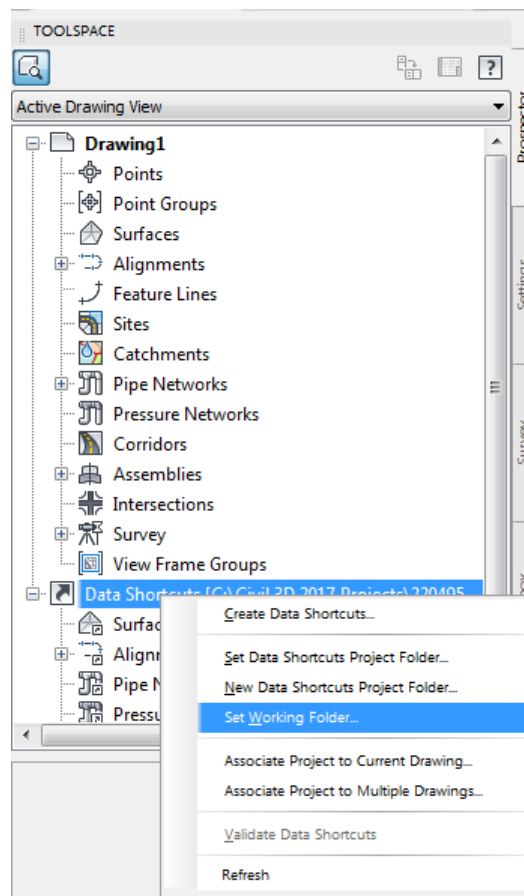

- From the Browse For Folder dialog box, use the scroll bar to navigate and click on the **C:\Civil 3D 2017 Projects** folder. Click **OK** to close the Browse For Folder dialog.

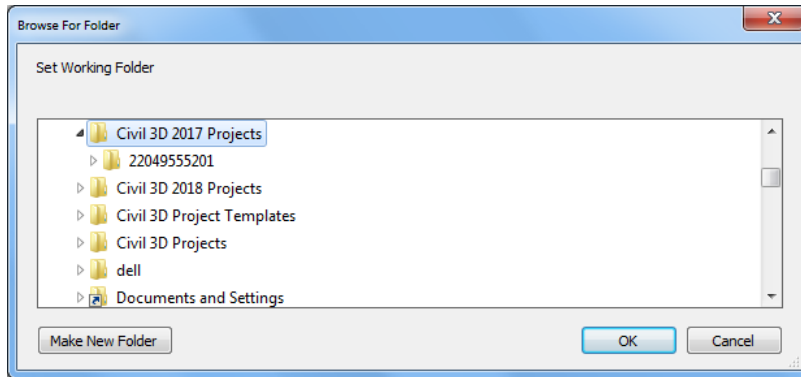

- From **TOOLSPACE > Prospector tab > Data Shortcuts**, right click and select **Set Data Shortcuts Project Folder**.

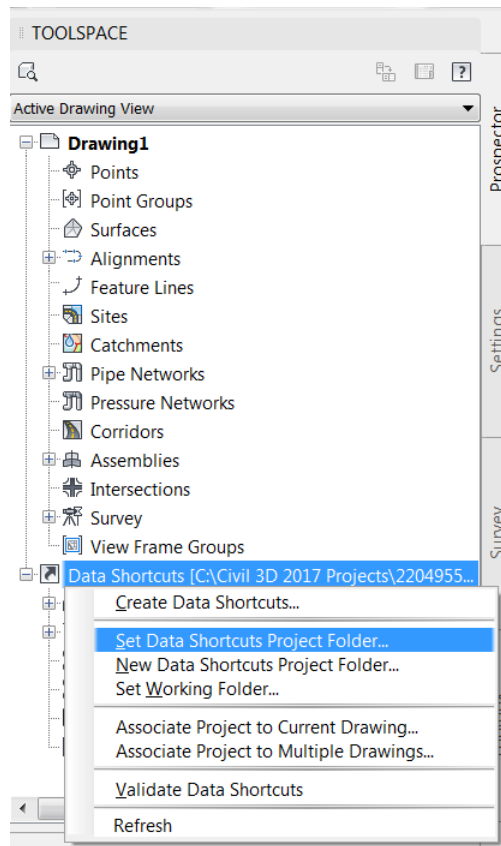

Exercise 6.3 Create MODLRD01-Existing Conditions file

In this exercise you will create the MODLRD01-Existing Condition file

1. From the **FDOT Tab > Create File Panel** select the **Create Files** icon
2. Make the project **22041255201** current. (**Use Select Project Button**)
3. Select Control File: **ROADWAY**
4. Select File Group: **Roadway Files** (DWG)
5. Select File Type: **Proposed Design Model** (MODLRD01)
6. Set the **MODLRD01.dwg** County to **Wakulla**
7. Set the **MODLRD01.dwg** Coordinate System to **FL83-NF**
8. Click **“Create - Open File”** to create **MODLRD01.dwg** file
9. Click **“Close”** to close Create Files Tool

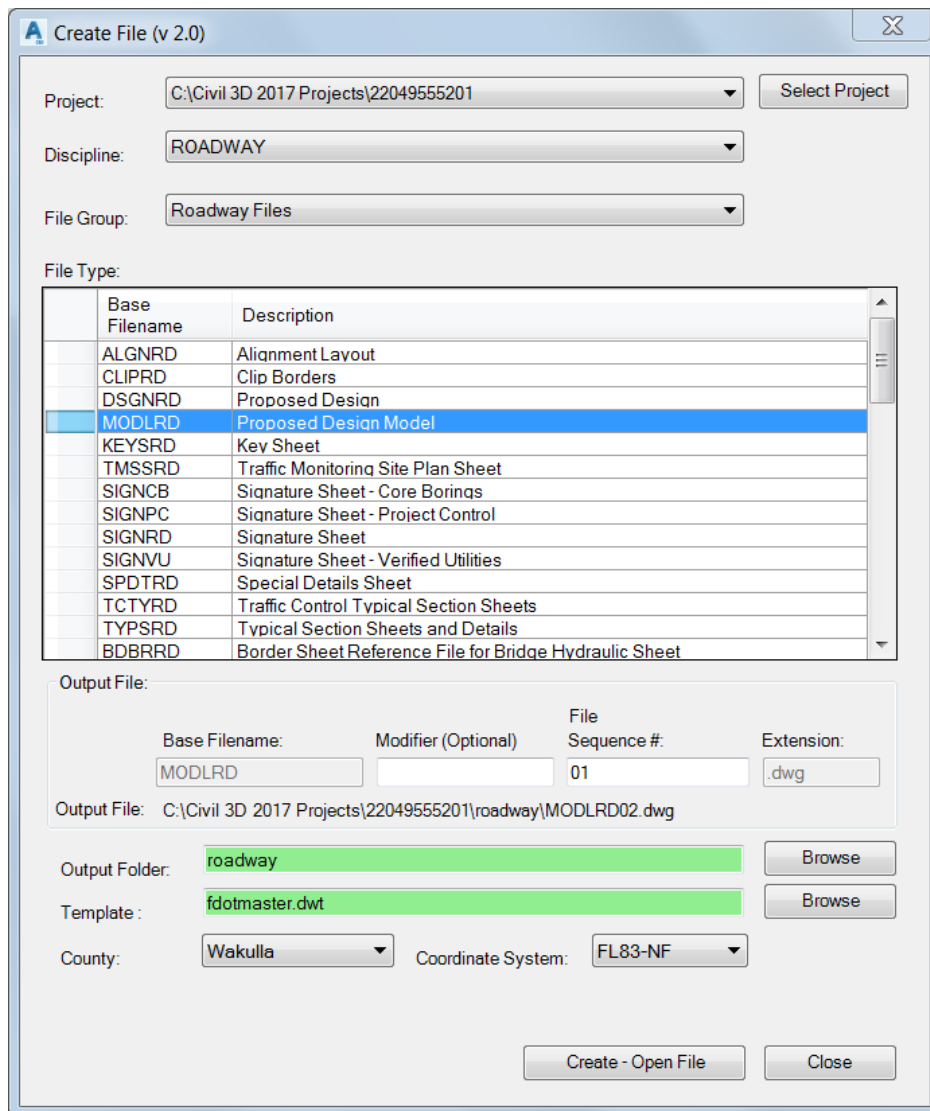

10. Switch to the **MODLRD01.dwg** file in the current session of Civil 3D
11. Using the **Saveas** command save the **MODLRD01.dwg** as **MODLRD01-Existing Conditions.dwg** .

Exercise 6.4 Associate Project to Current Drawing

In this exercise you will associate the **MODLRD01-Existing Conditions** file to the current project.

1. From the TOOLSPACE, Prospector tab, right-click on Data Shortcuts, then select **Associate Project to Current Drawing**.

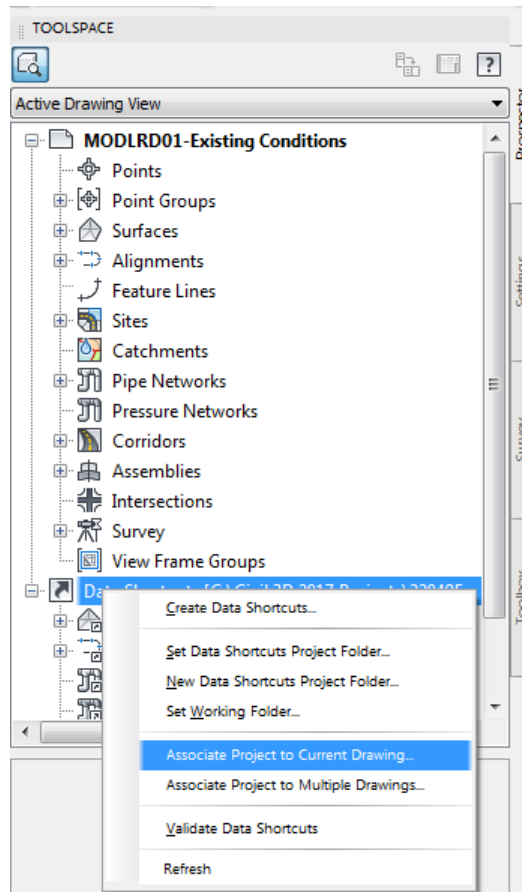

2. From the Associate Project to Current Drawing dialog, click OK

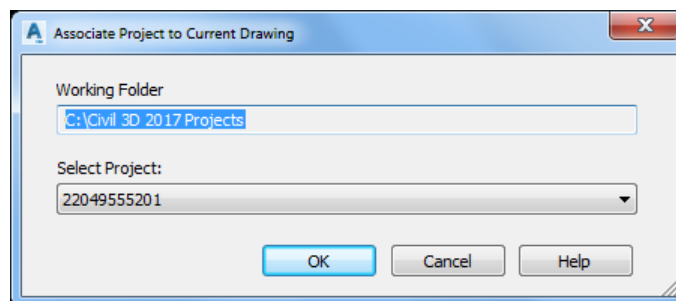

3. **Save** the MODLRD01-Existing Conditions.dwg file

Exercise 6.5 Attach External Reference file TOPORD01.dwg

In this exercise you will attach an external reference file to the MODLRD01-Existing Conditions file.

1. From the **Home Tab > Layers Panel**, set the current Layer to Xreference01_dp

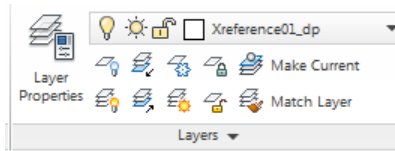

2. From the Insert Tab > Reference Panel, select Attach

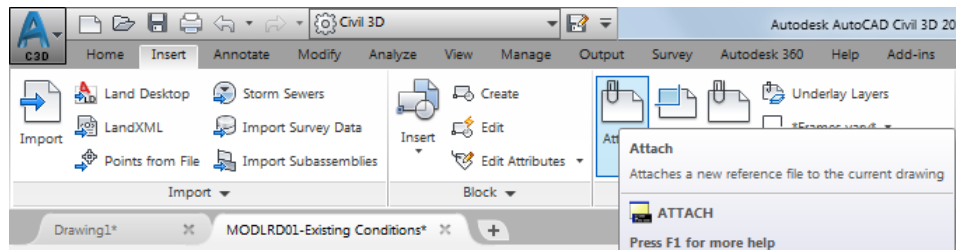

3. From the Select Reference dialog, navigate to the C:\Civil 3D 2017 Projects\22049555201\Survey folder, select the TOPORD01.dwg file, then Click Open.

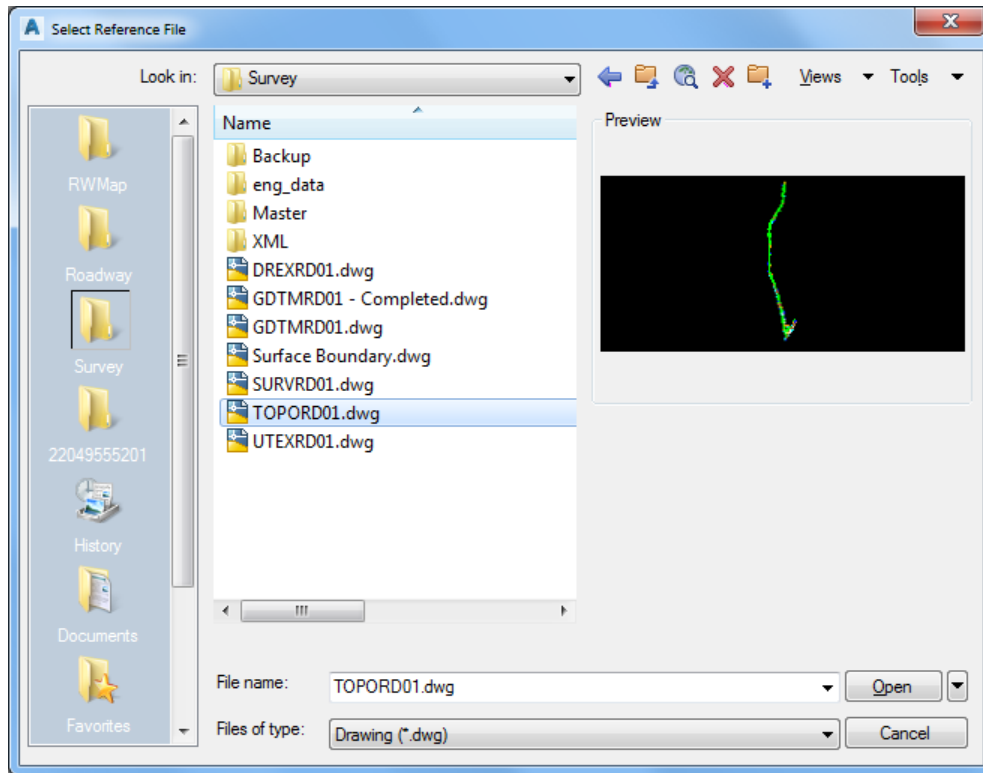

- From the Attach External Reference dialog, for Reference Type select Overlay, clear Scale, Insertion point, and Rotation boxes, then Click OK.

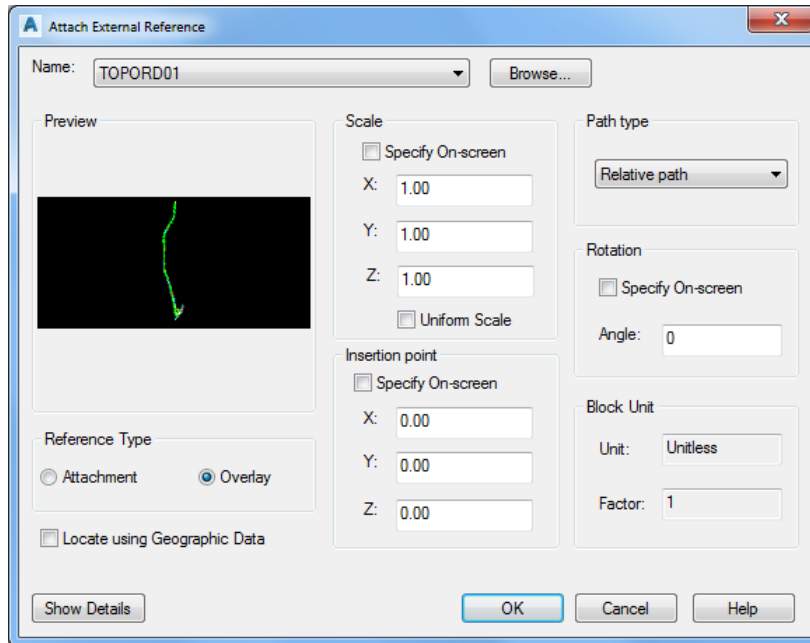

- Perform a Zoom Window to display the 22049555201 project location

[1]Top[2D Wireframe]

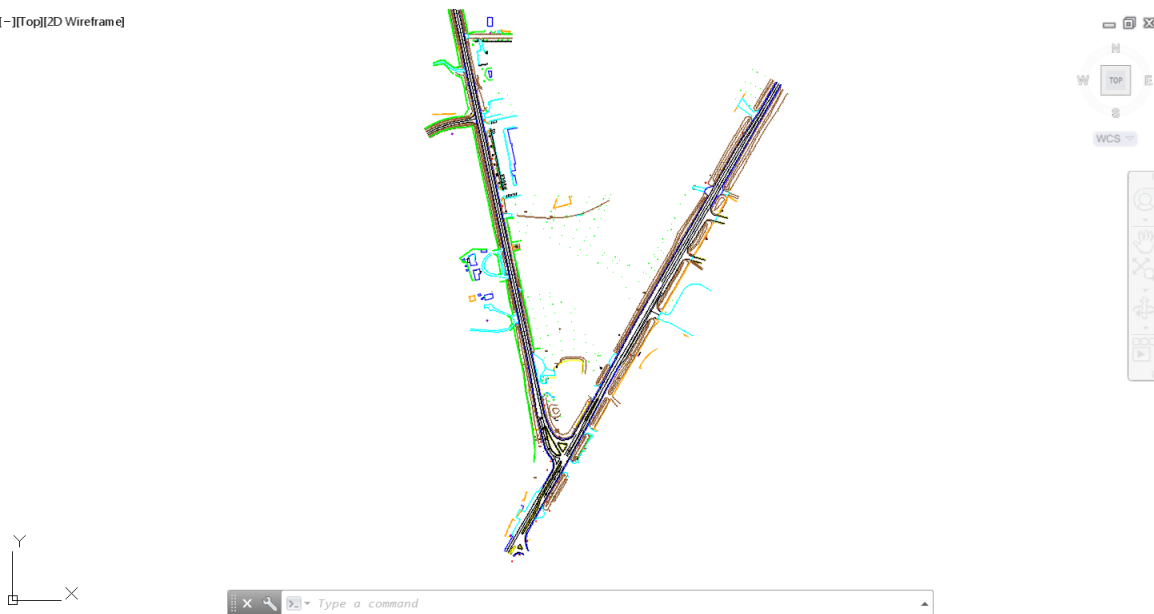

- Save the MODLRD01-Existing Conditions.dwg file

Exercise 6.6 Create Data Shortcut Reference for DTM Existing Surface

In this exercise you will create Data Shortcut references to the DTM Existing Surface.

1. From the TOOLSPACE, Prospector tab, expand Data Shortcuts, then expand the Surfaces collection, right-click on DTM Existing, then select Create Reference.

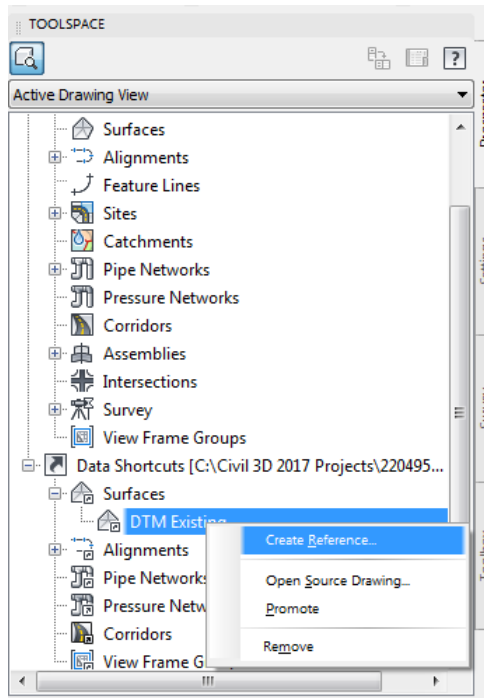

2. From the Create Surface Reference dialog, use DTM Existing as Name, and set Style to Border-Existing [Green] select Surfaces, then Click OK.

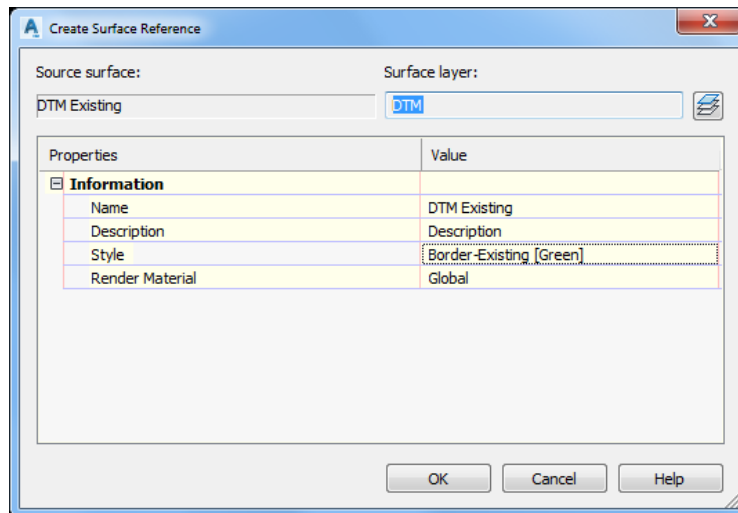

3. From the TOOLSPACE, Prospector tab, expand the Surfaces collection.

- Verify that the Surface DTM Existing is listed.

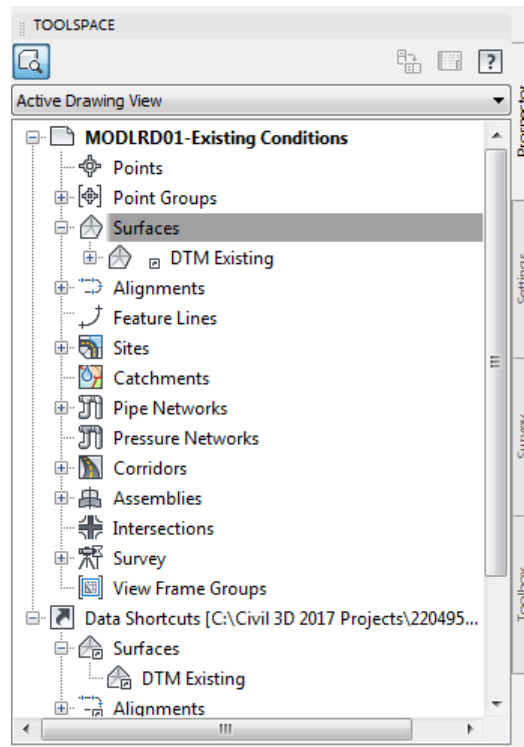

- Perform a Zoom Window to display the 22049555201 project location displaying the DTM Existing surface.

[1]Top|2D Wireframe



- Save the MODLRD01-Existing Conditions.dwg file

Exercise 6.7 Create Data Shortcut Reference for EX-SR61, SR61 and US98 Alignments

In this exercise you will create Data Shortcut references to for the EX-SR61, SR61 and US 98 Alignments.

1. From the TOOLSPACE, Prospector tab, expand Data Shortcuts, expand the Alignments collection, then expand the Centerline Alignments, right-click on DTM Existing, then select Create Reference...

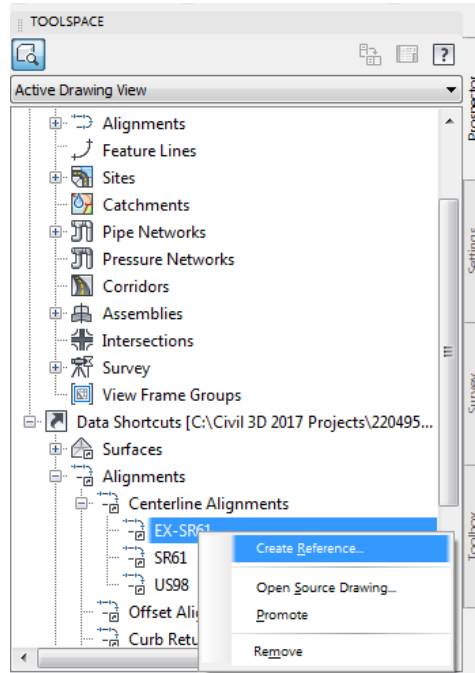

2. From the Create Alignment Reference dialog, use EX-SR61 as Name, set Alignment style to FDOT Existing, select Surfaces, set Alignment label set to Truncated Scale 1-40, and then Click OK.

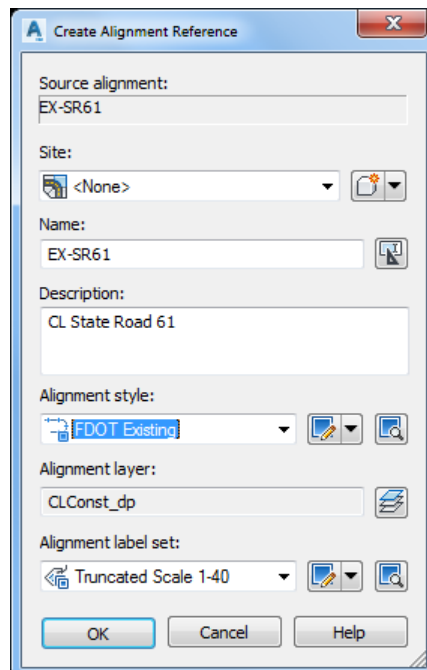

3. Repeat Step 4 steps to Create **References** for Centerline Alignments **SR61 and US98**.
 - a) For Centerline Alignment **SR61**, set Alignment style to FDOT Proposed.
 - b) For Centerline Alignment **US98**, set Alignment style to FDOT Existing.
 - c) Use default settings for other values.



4. From the TOOLSPACE, Prospector tab, expand the Alignment collection, then expand Centerline Alignments.
5. Verify that Centerline Alignments EX-SR61, SR61 and US98 are listed.

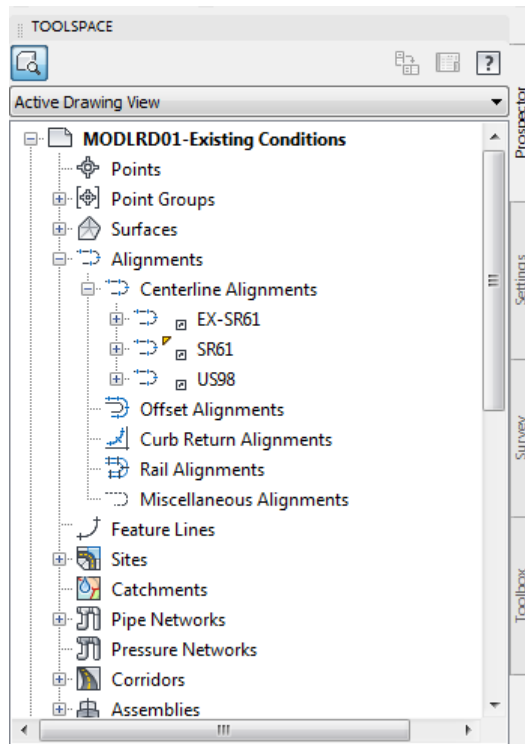

[1-]Top][2D Wireframe]



6. **Save** the MODLRD01-Existing Conditions.dwg file

Exercise 6.8 Create Existing Surface Profile for SR61 Centerline Alignment

In this exercise you will create the Existing Surface Profile for the SR61 Centerline Alignment..

1. From the Home Tab > Create Design Panel, select Profile, then select Create Surface Profile.

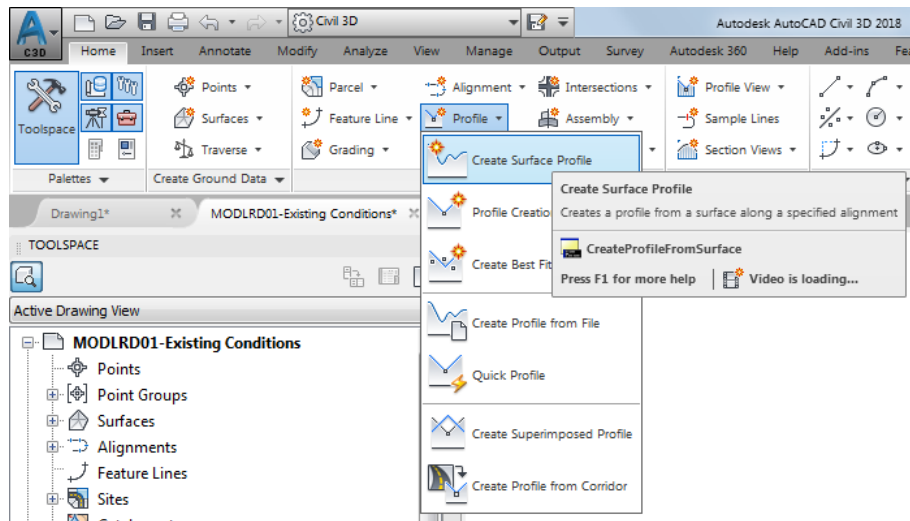

2. From Create Profile from Surface dialog, for Alignment select SR61, for Surface select DTM Existing, Click Add>>, set Style to FDOT Existing, then Click Draw in profile view.

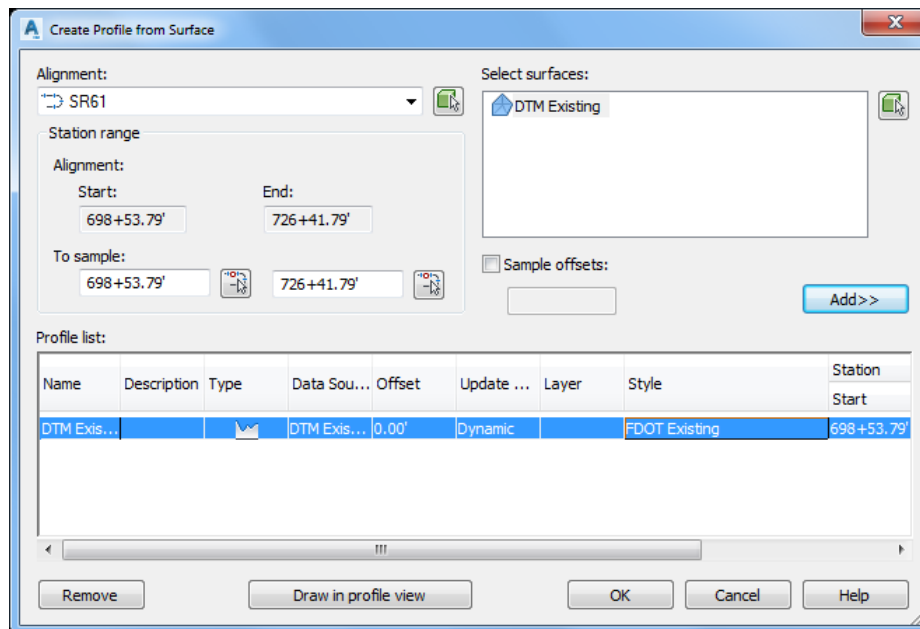

- From the Create Profile View -General dialog, set Profile view style to FDOT 40 Horz x 4 Vert Scale 10x GRID ON, then Click on Next >.

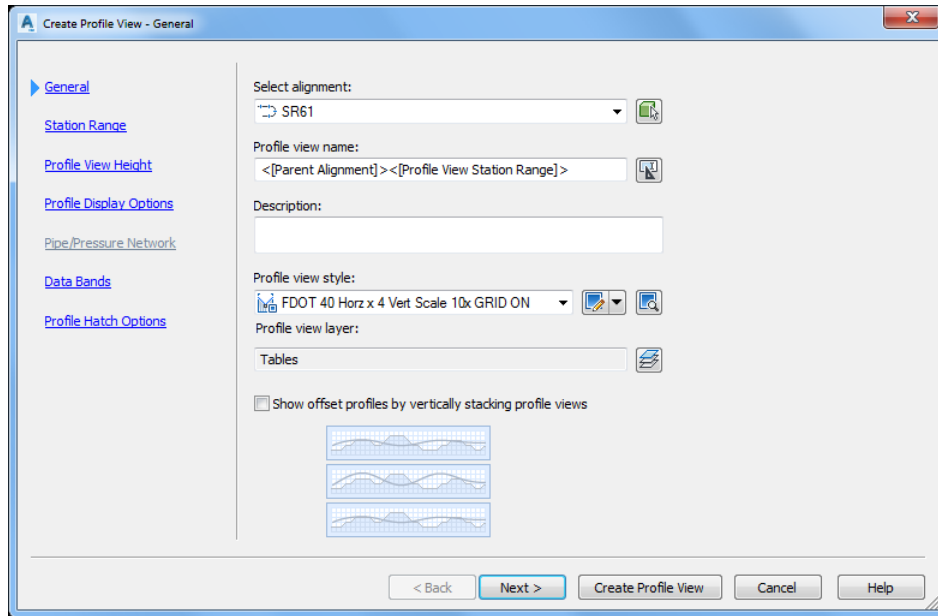

- From the Create Profile View - Station Range dialog, Click on Next >.

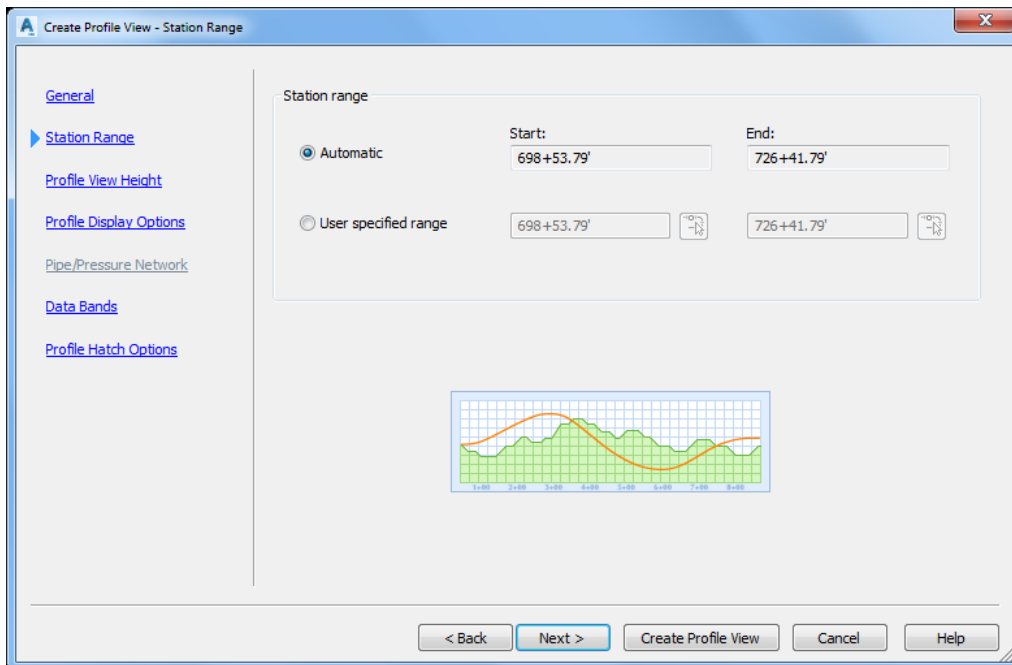

- From the Create Profile View - Profile View Height dialog, Click on Next >.

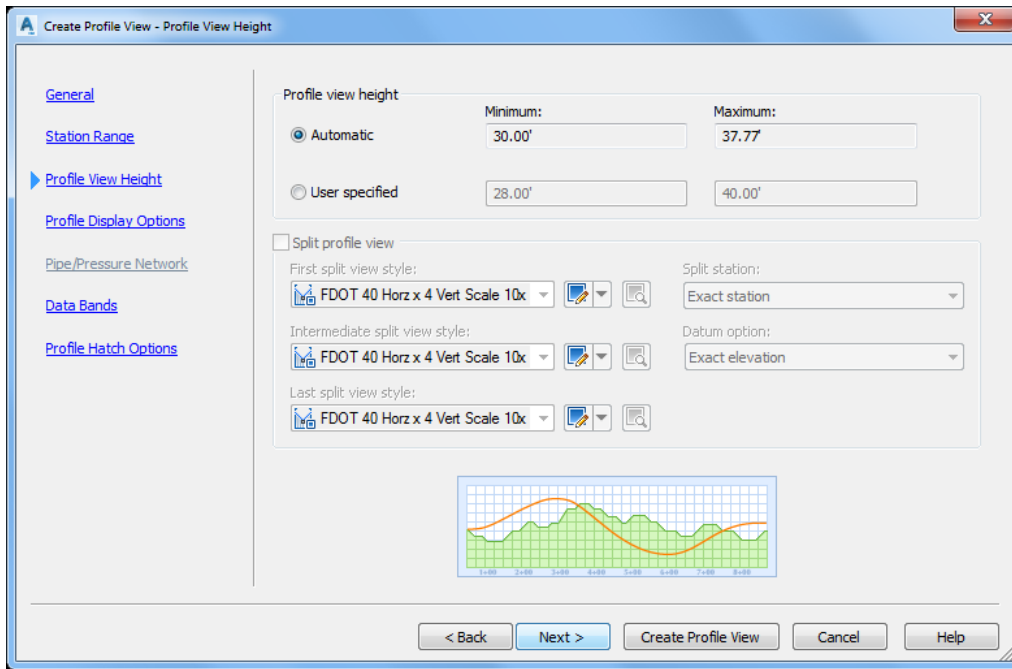

- From the Create Profile View - Profile Display Options dialog, set Style to FDOT Existing, then Click on Next >.

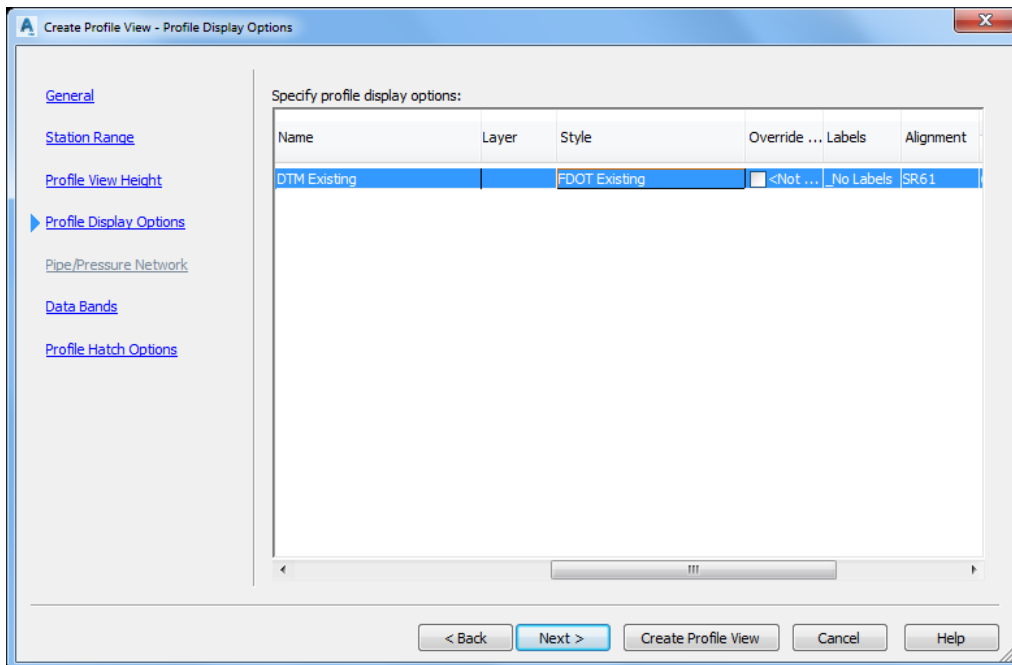

7. From the Create Profile View - Data Bands dialog, Click on Next >.

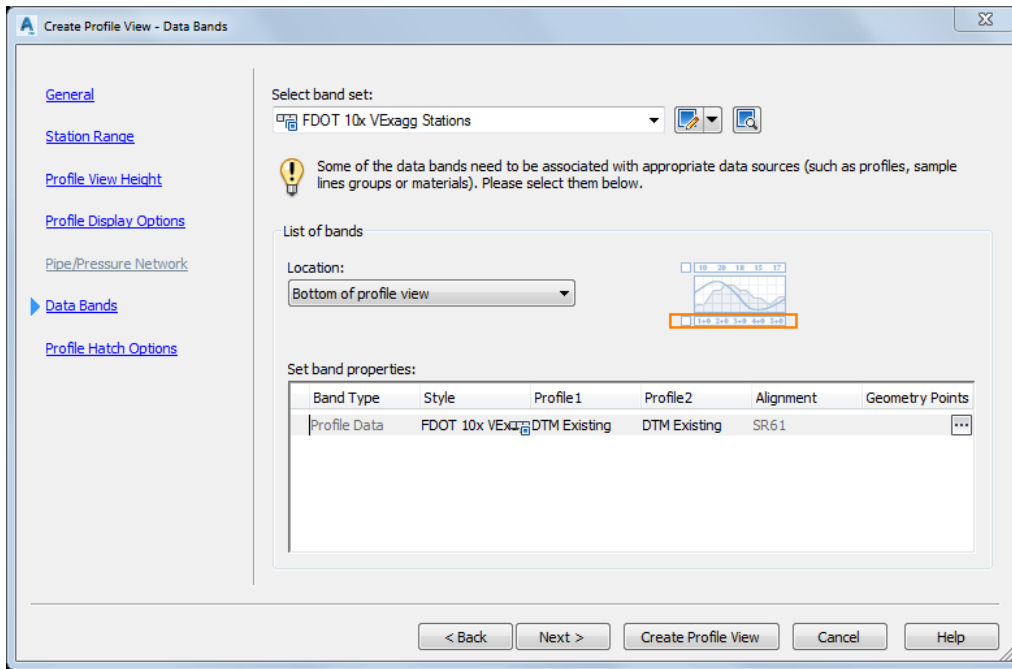

8. From the Create Profile View - Profile Hatch Options dialog, Click on Create Profile View.

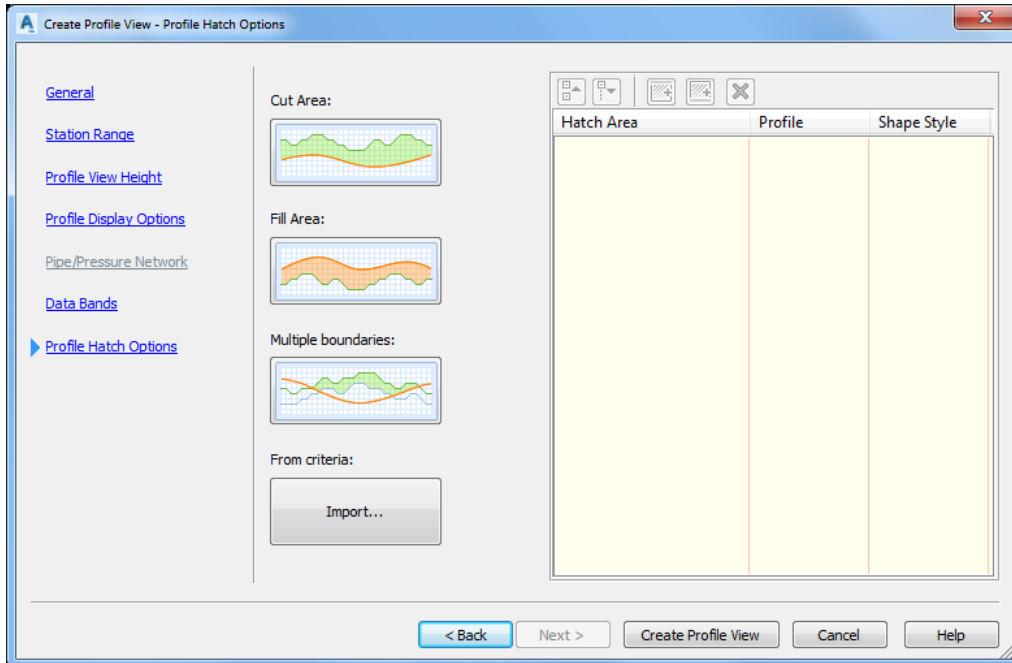

9. Place Profile View to the right of the 22049555201 project location.

10. Perform a Zoom Window to display the 22049555201 project location and the SR61 Profile View.

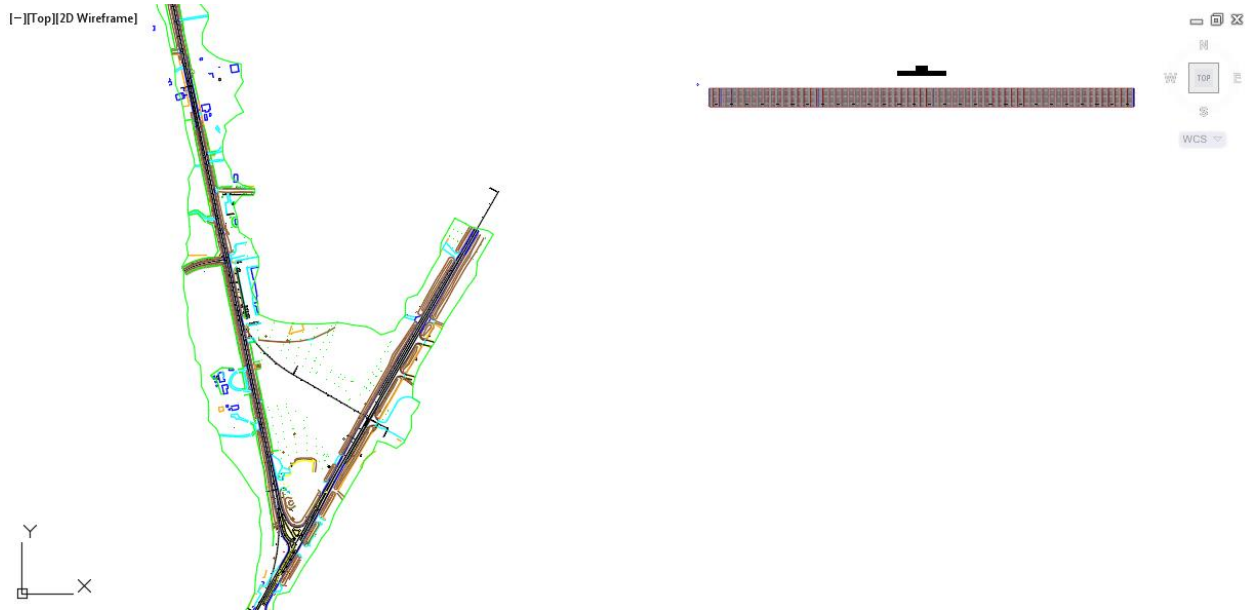

11. **Save** the MODLRD01-Existing Conditions.dwg file

Exercise 6.9 Create Existing Condition Assembly

In this exercise you will create the Existing Condition Assembly.

1. From the **Home Tab > Create Design Panel**, select **Assembly**, then select **Create Assembly**.

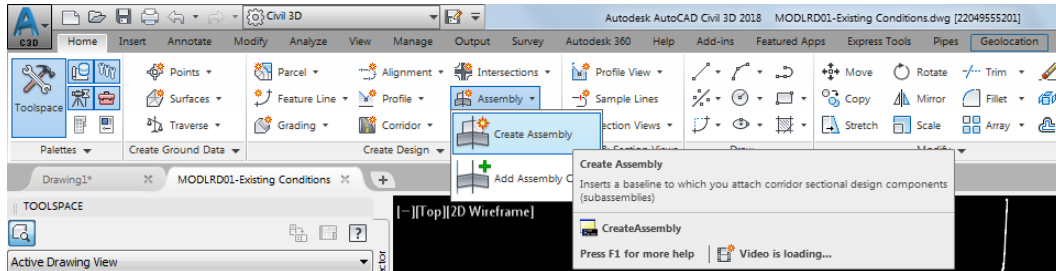

2. From the **Create Assembly dialog**, for **Name**: use **Existing Conditions**, set **Assembly** to **Other**, set **Assembly style** to **FDOT**, set **Code set style** to **FDOT XSection Existing**, then **Click OK**

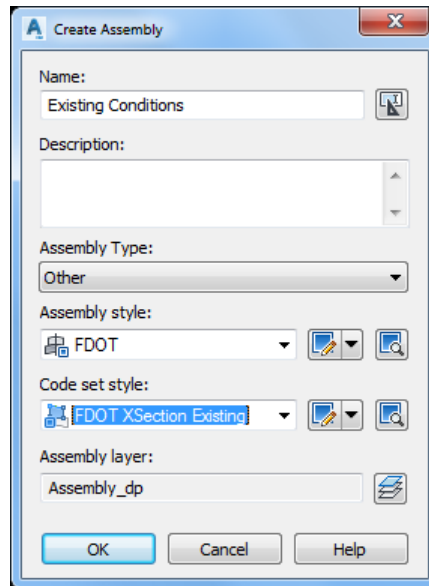

3. Place the **Existing Conditions assembly marker** to left of the **SR61 Profile View**

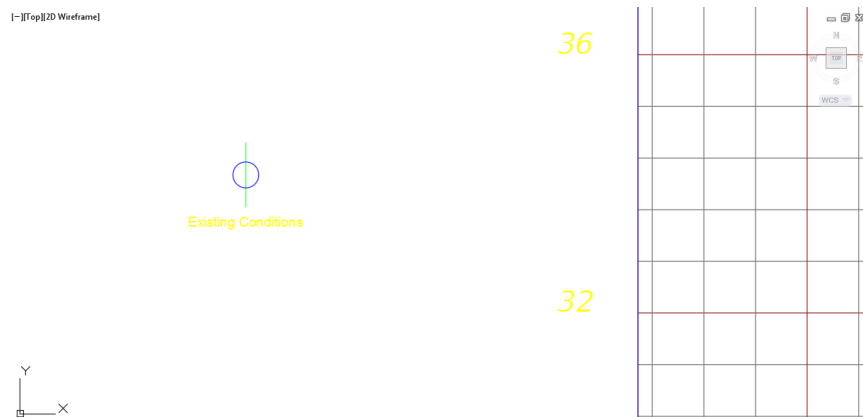

- From the Home Tab > Palettes Panel, select Tool Palettes.

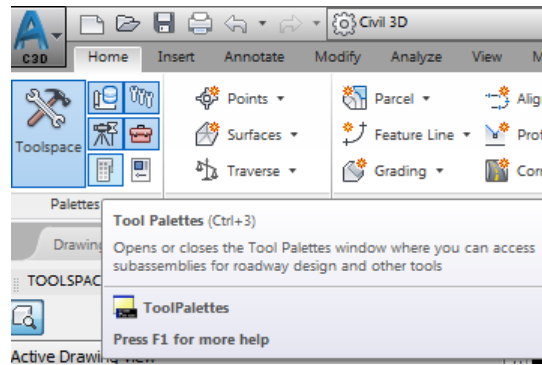

- Right-click on the Tool Palette title bar, select FDOT Subassemblies, then select the Assemblies Tab.

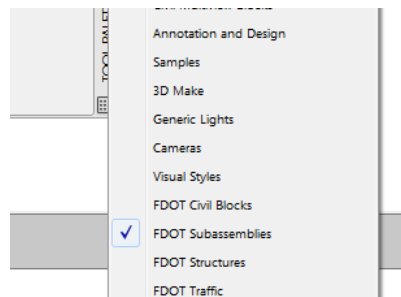

- Select the FDOT Existing Features assembly.

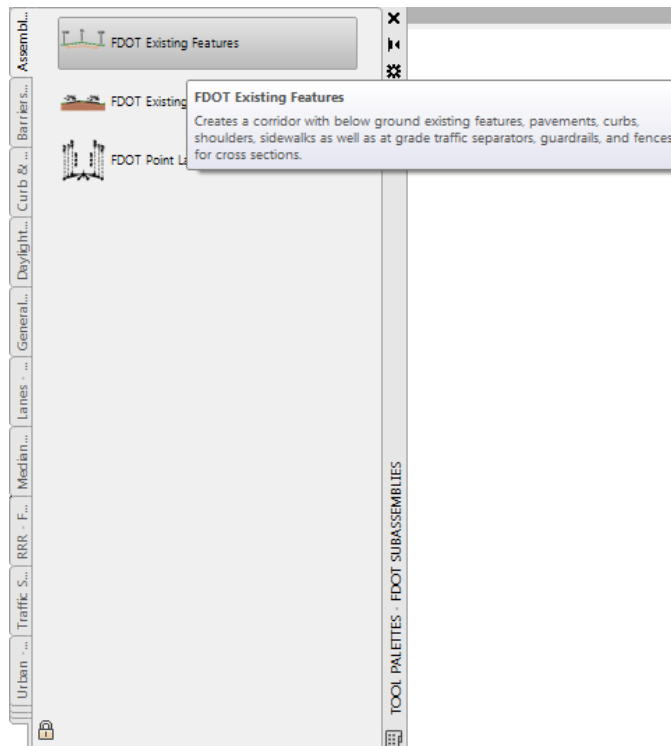

7. Review Parameters settings of the FDOT Existing Features assembly in the Properties Palette.

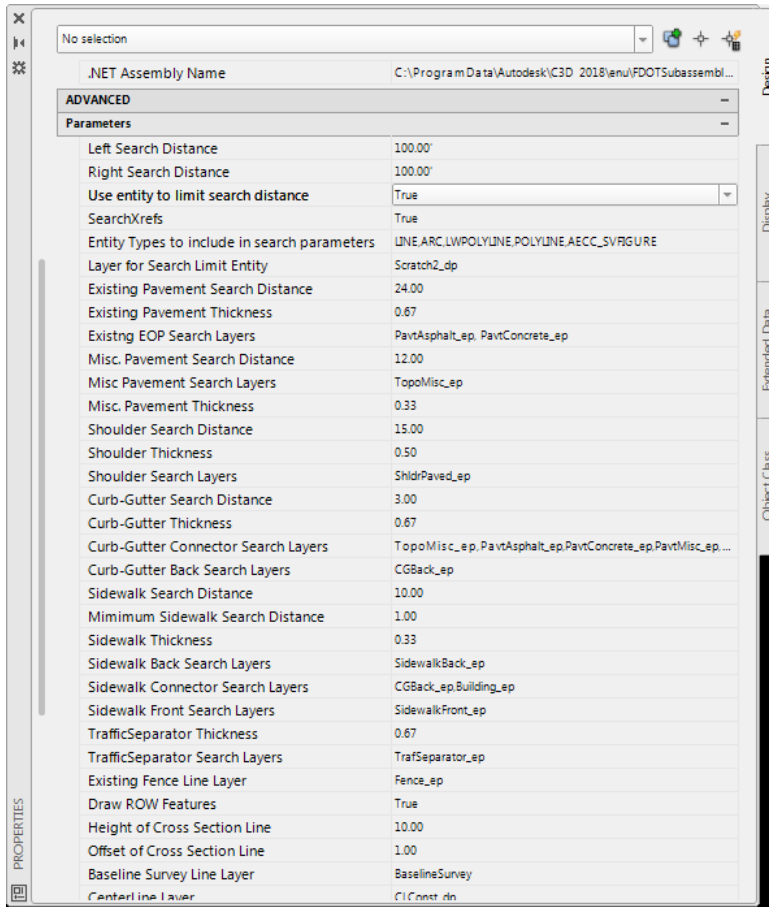

- 8. Select the Existing Condition assembly marker to place FDOT Existing Features Assembly, then press Enter to end command.

[-][Top][2D Wireframe]



36

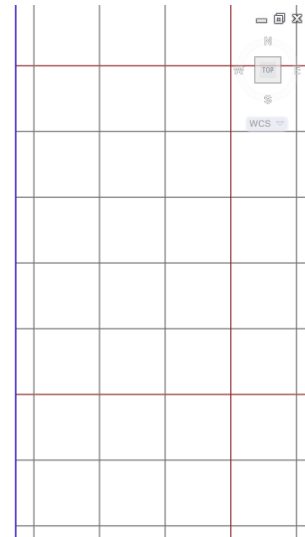

32

- 9. Close the **FDOT Subassemblies** Tool Palette.

- 10. Perform a Zoom Window to display the 22049555201 project location and the SR61 Profile View.

[-][Top][2D Wireframe]

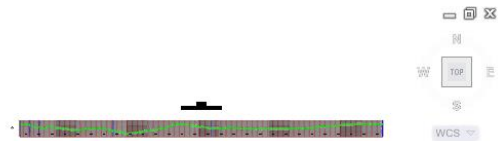

- 11. **Save** the MODLRD01-Existing Conditions.dwg file

Exercise 6.10 Create SR61 - Existing Conditions Corridor

In this exercise you will create the SR61 - Existing Conditions Corridor.

1. From the **Home Tab > Create Design Panel**, select Corridor, then select Corridor.

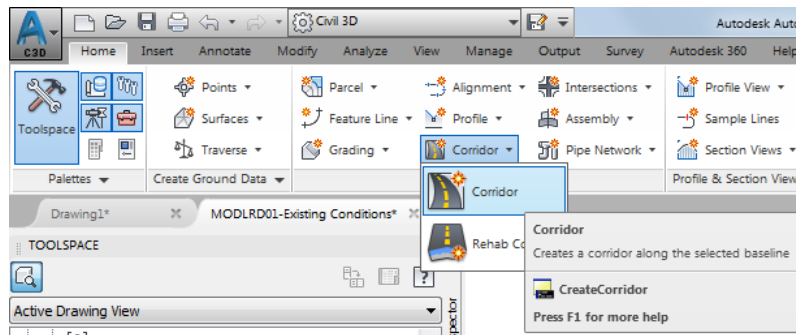

2. From the Create Corridor dialog, use the following values:

Name: SR61 - Existing Conditions

Corridor style: FDOT

Baseline type:

Select Alignment and profile

Alignment: SR61

Profile: DTM Existing

Assembly: Existing Conditions

Target Surface: DTM Existing

Click on Set baseline region parameters

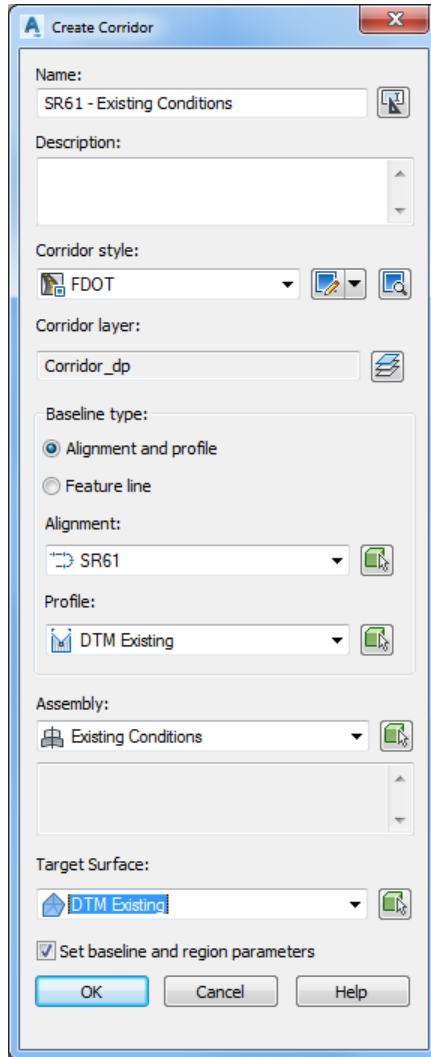

3. Click OK

- From Baseline and Region Parameters - SR61 - Existing Conditions dialog, Set Start Station to **700+50**, set End Station to **715+50**

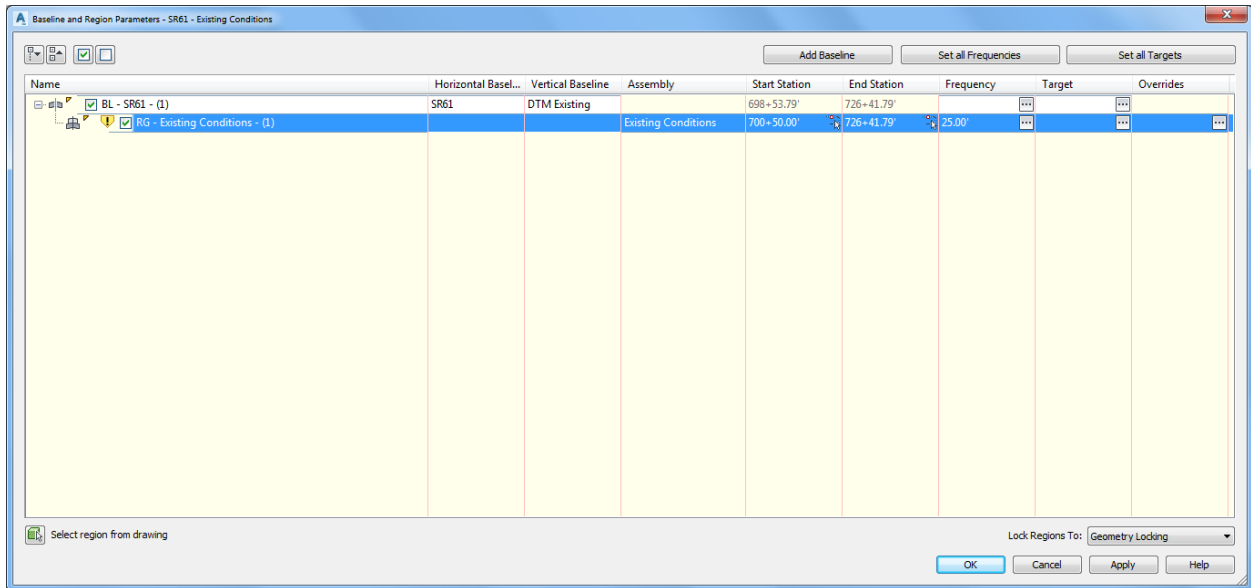

- Select **Frequency icon**, then set Frequency's to 50', points values to No, then click OK

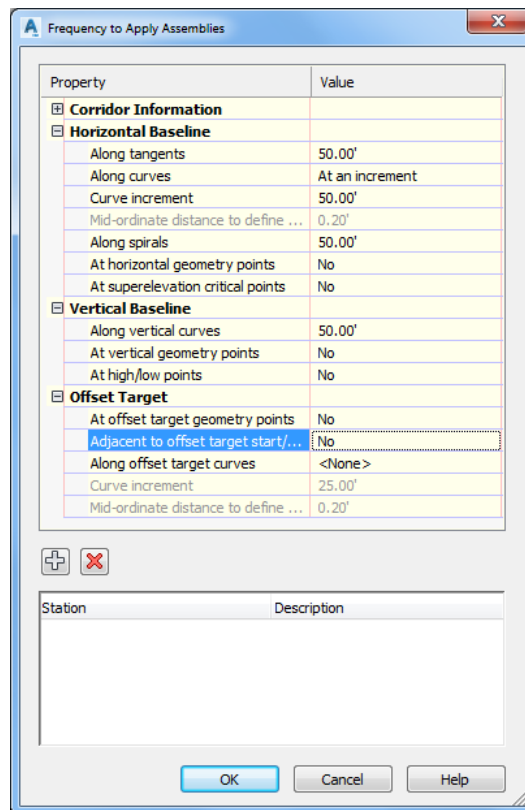

6. Select Target icon, set Existing surface to DTM Existing, then click OK.

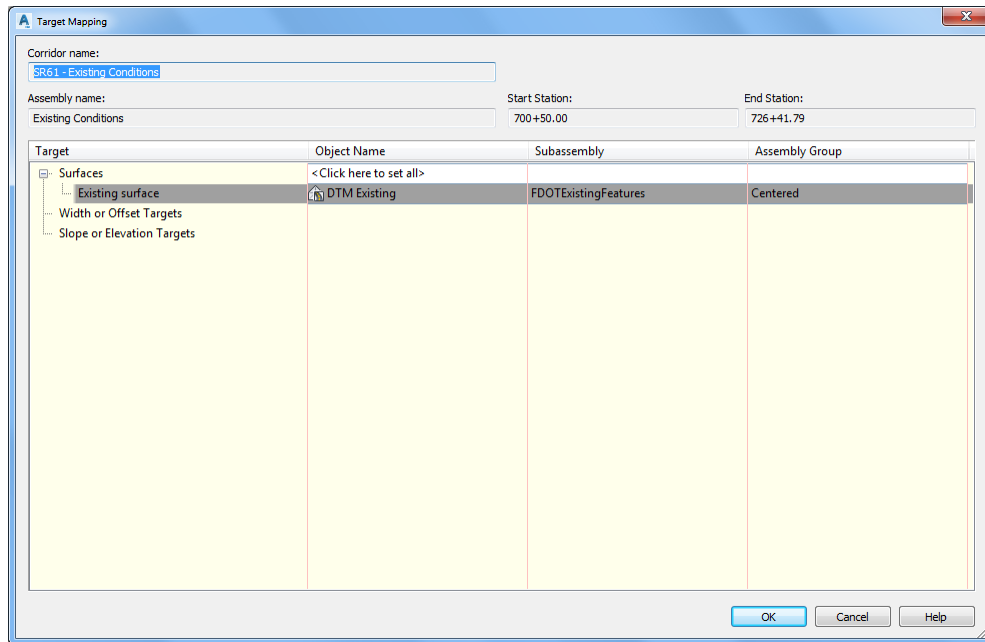

7. From Baseline and Region Parameters - SR61 - Existing Conditions dialog, click OK
8. From Corridor Properties - Rebuild dialog, click Rebuild the Corridor

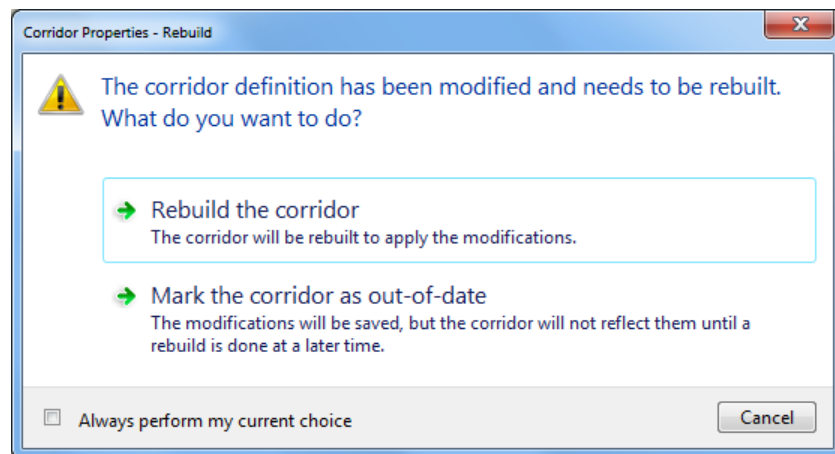

9. Review the events in the Event Viewer, clear events, then close the Event Viewer

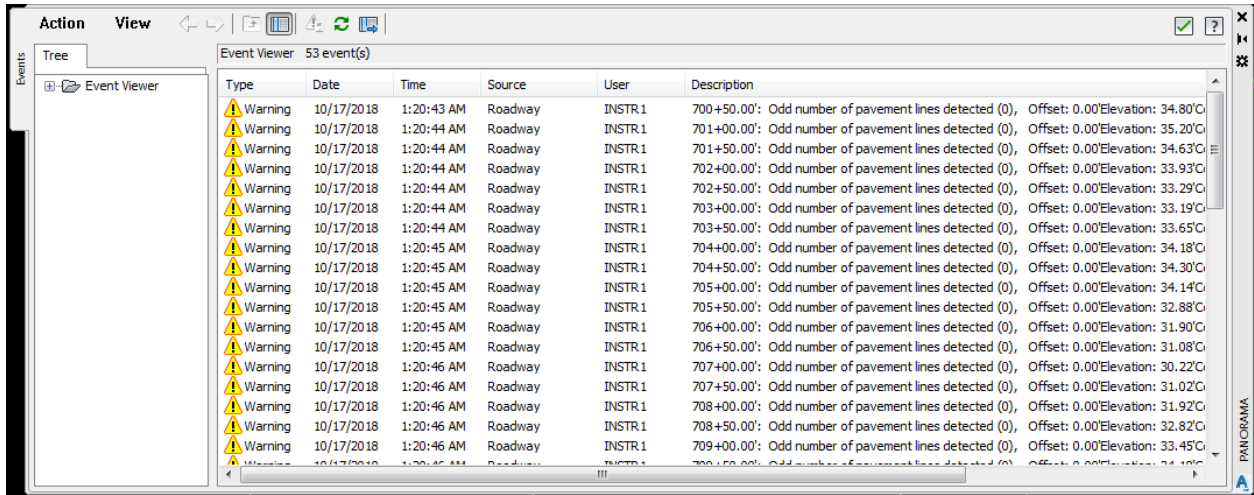

10. Perform a Zoom Window to display the 22049555201 project location and the SR61 Profile View.

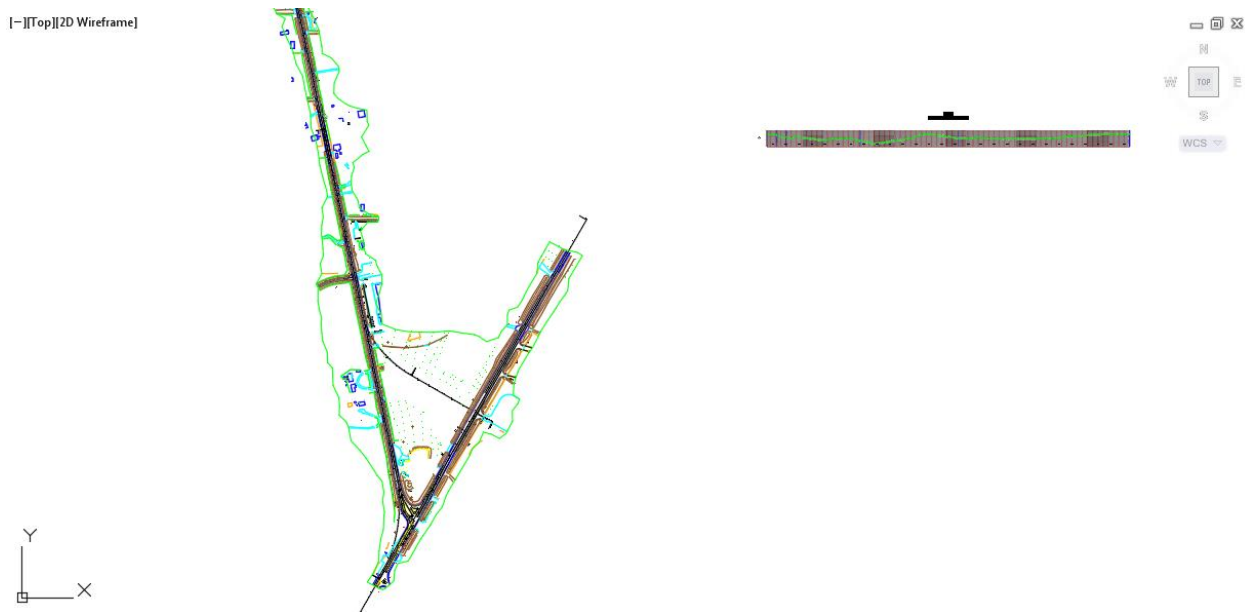

11. Save the MODLRD01-Existing Conditions.dwg file

Exercise 6.11 Create Sample Lines for SR61 Centerline Alignment

In this exercise you will create the Sample Lines for the SR61 Centerline Alignment.

1. From the Home Tab > Profile and Sections Panel, select Sample Lines, then press Enter.

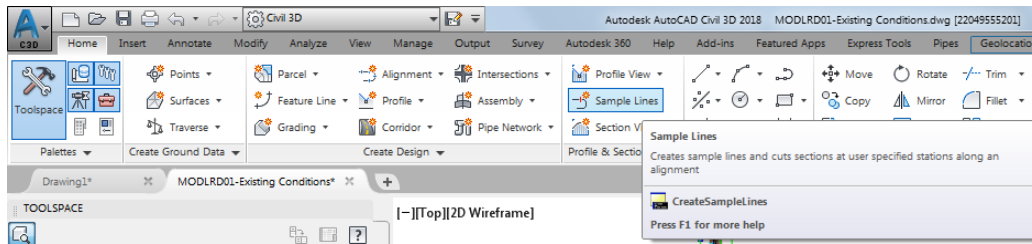

2. From the Select Alignment dialog, select **SR61**, then Click **OK**

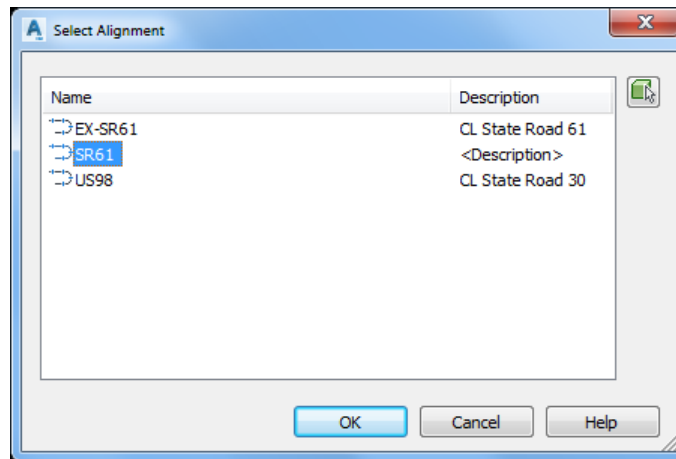

3. From the Create Sample Line Group dialog, for DTM Existing set Style to FDOT Existing, for SR61 - Existing Conditions set Style to FDOT XSection Existing, then click OK.

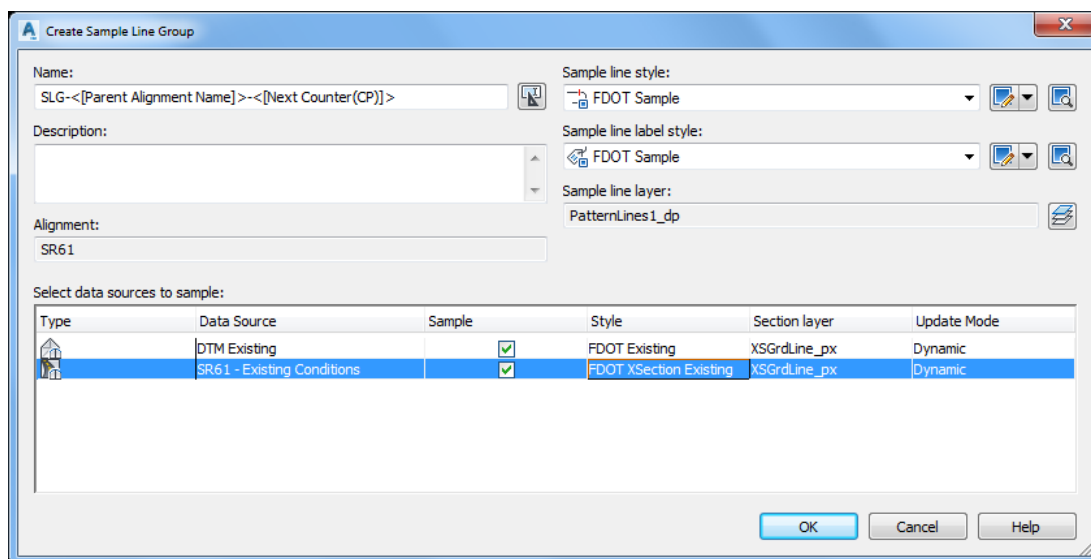

- From the Sample Line Tools toolbar, select **From corridor stations**

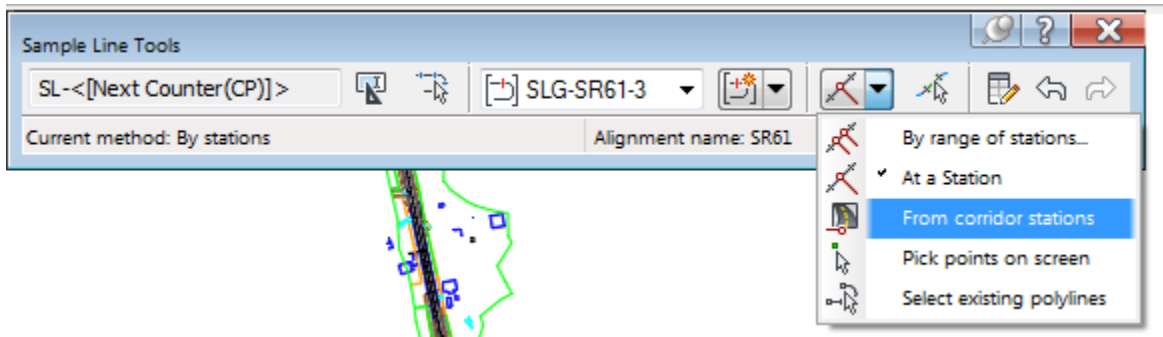

- From the Create Sample Lines - From Corridor Stations dialog, set From alignment start to False then set **Start Station** to 700+50, set To alignment end to False then set **End Station** to 715+50, set Left Swath Width to 120', set Right Swath Width to 120', then click OK.

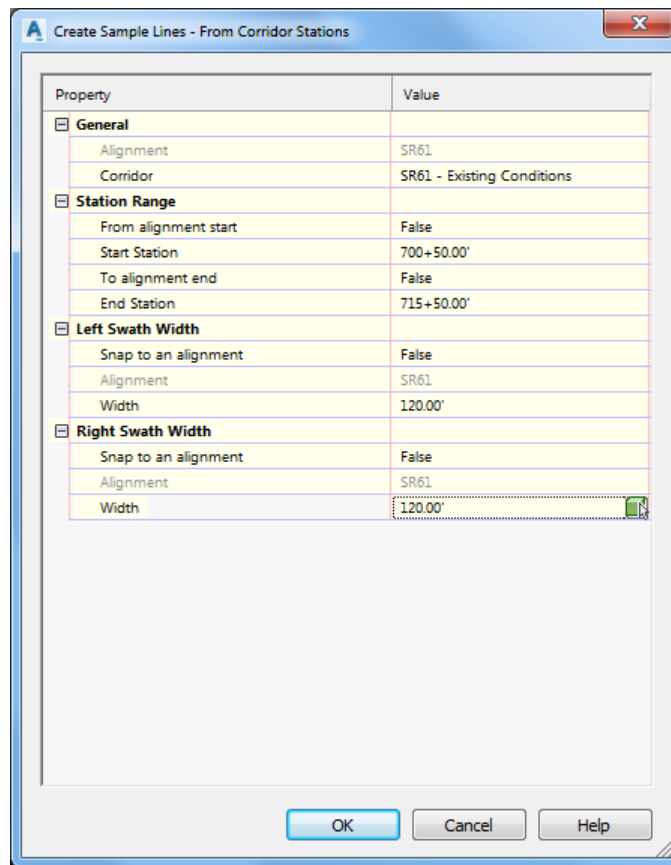

- Press Enter to end command.
- Perform a Zoom Window to display the 22049555201 project location and the SR61 Profile View.

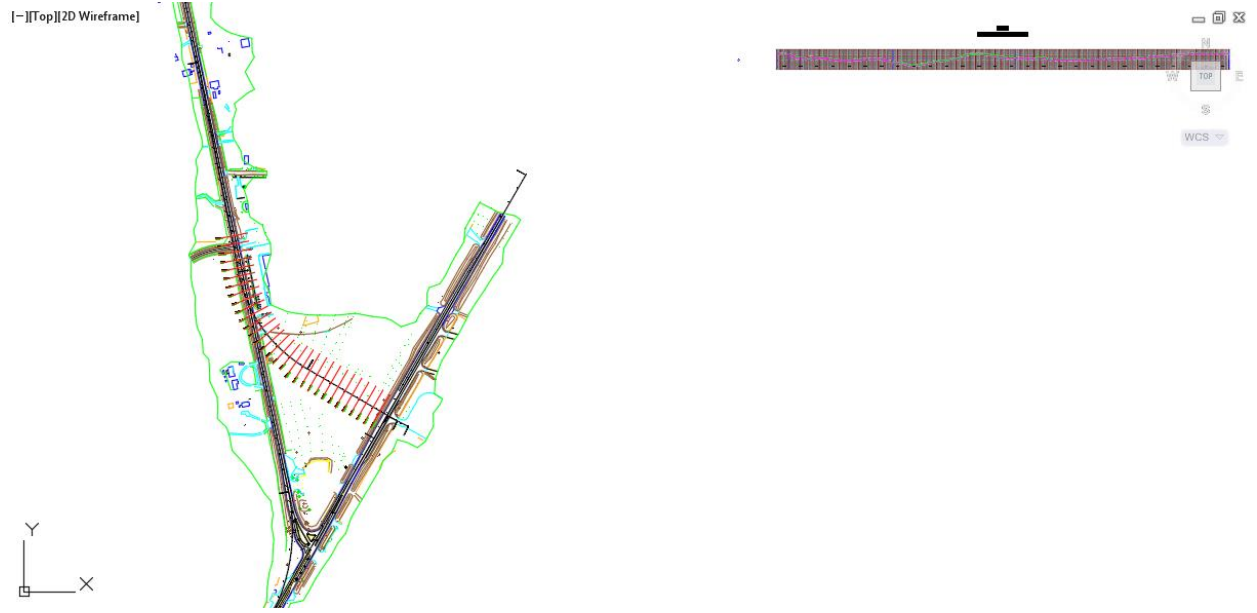

8. **Save** the MODLRD01-Existing Conditions.dwg file

Exercise 6.12 Create Cross Sections Views for the SR61 Centerline Alignment

In this exercise you will create Cross Section Views for the SR61 Centerline Alignment.

1. From the Status bar, Set the Annotation scale of the current view to 1" = 40'

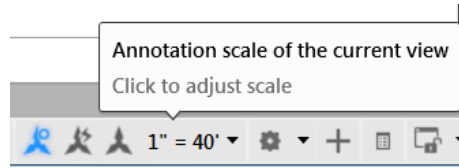

2. From the Home Tab > Profile and Sections Panel, select Section Views, then select Create Multiple Views.

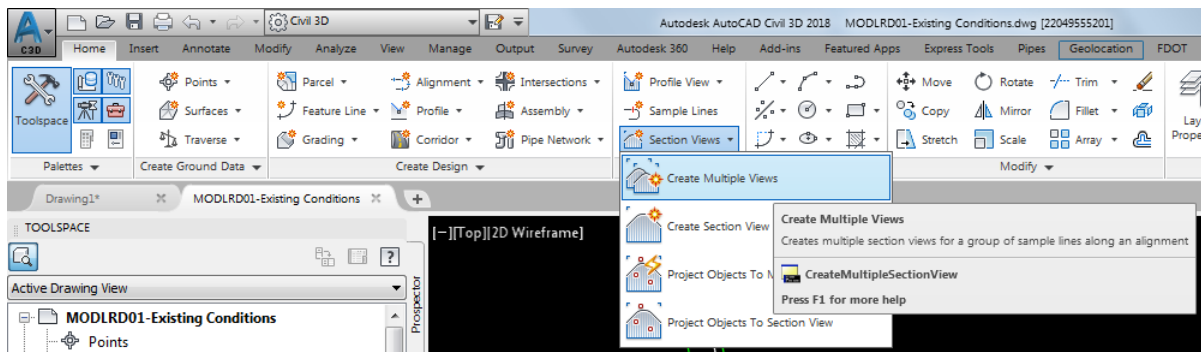

3. From Create Multiple Section Views - General dialog, Set Station Range to User specified, set Start to 700+50, set End to 715+50, set Section view style to FDOT 40 Horz x 10 Vert 4X GRID ON, then click Next >

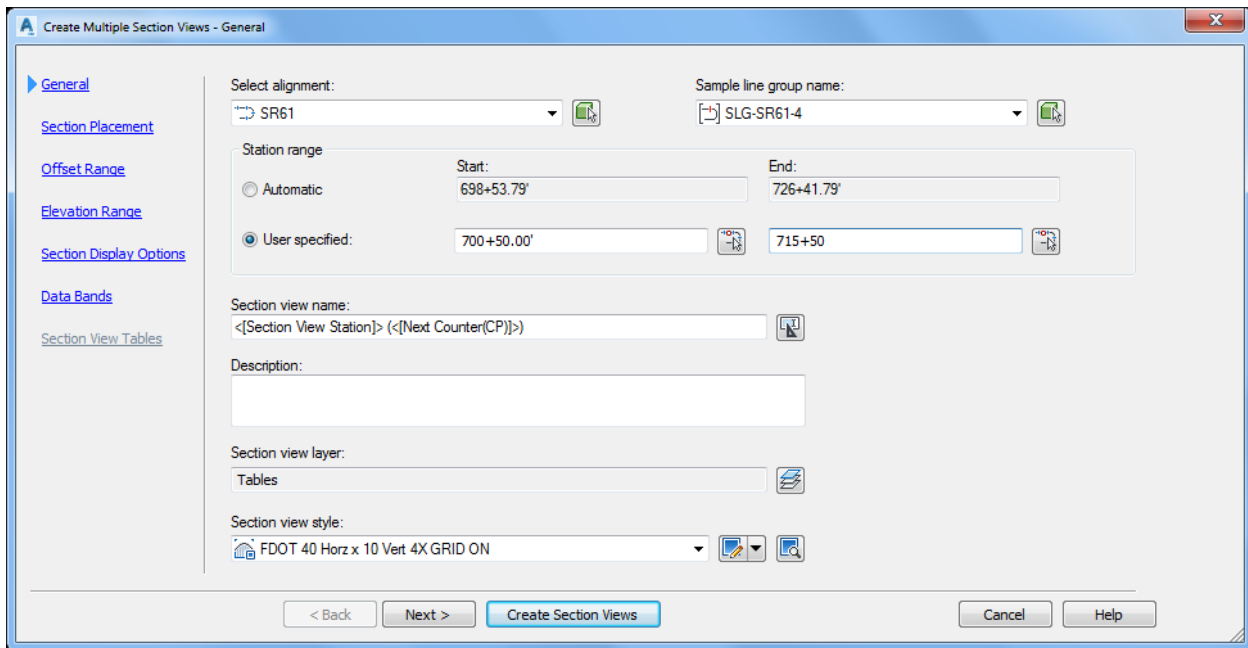

- From Create Multiple Section Views - Section Placement dialog, set the Template for cross section sheet to C:\FDOT2018.C3D\Data\Templates\Sheets\Roadway\SHXSC.dwt\40 Horiz x 10 Vert, select the box with the three dots referenced by the Red arrow.

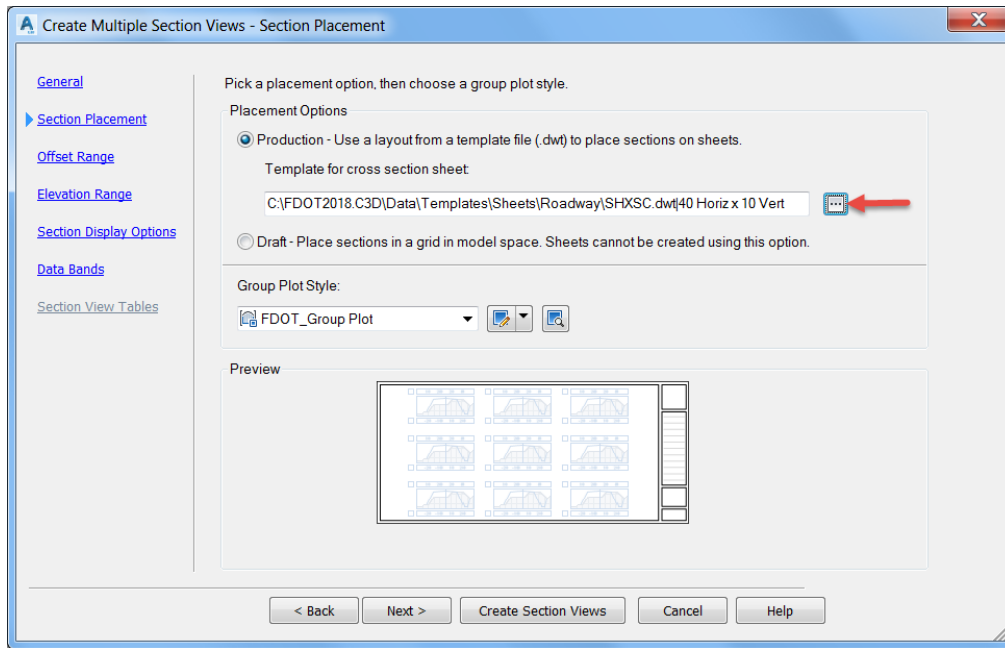

- From the Select Layout as Sheet Template dialog, select the box with the three dots referenced by the Red arrow to select the Drawing template file name.

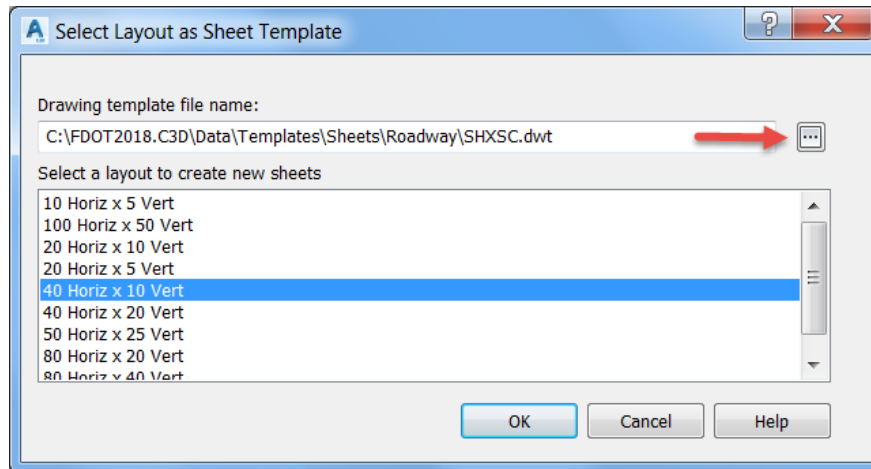

- From the Select Layout as Sheet Template dialog, double-click on the Sheets folder.

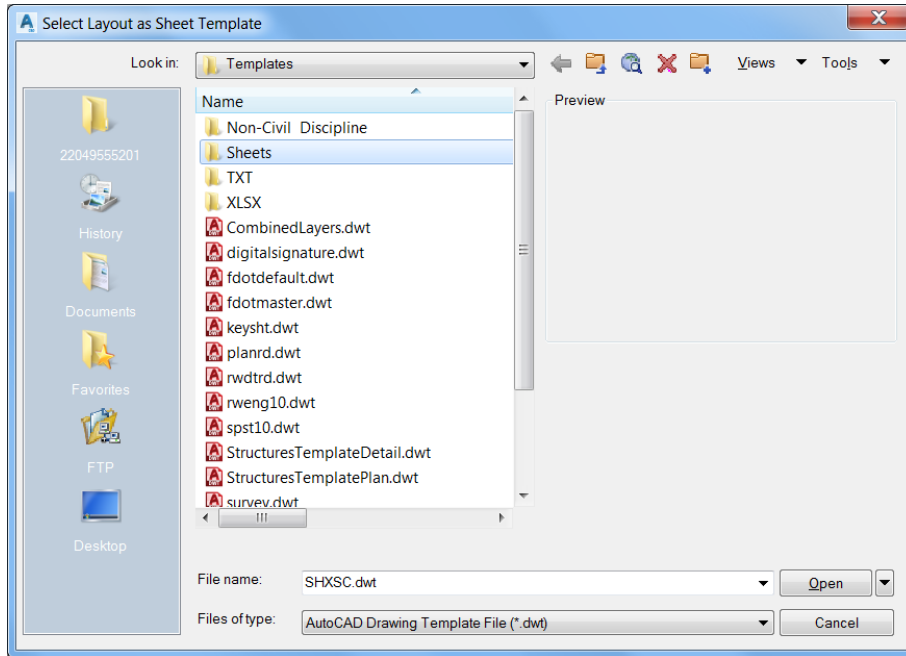

- From the Select Layout as Sheet Template dialog, double-click on the Roadway folder.

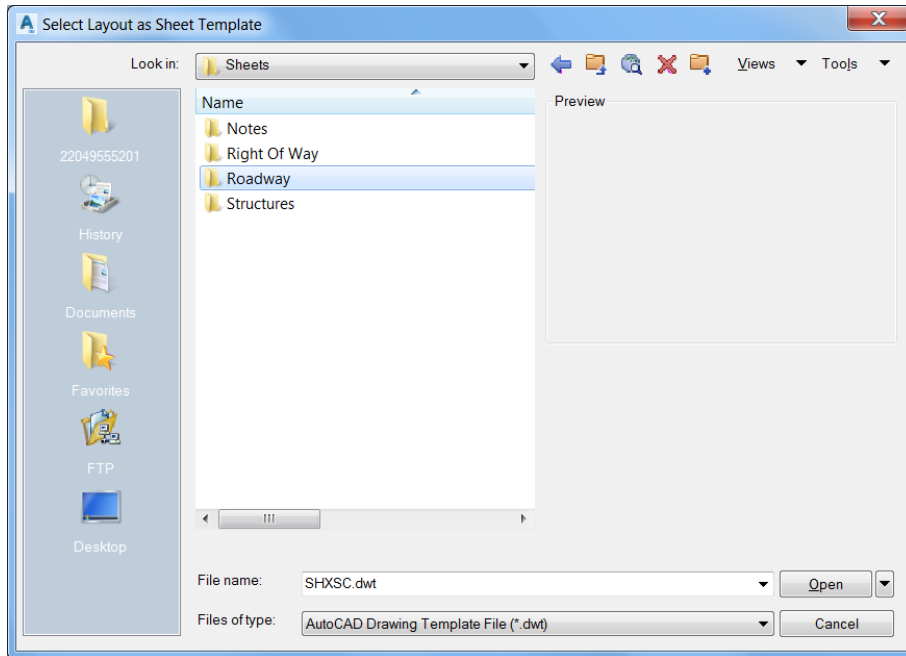

- From the Select Layout as Sheet Template dialog, select the SHXSC.dwt file, then Click Open.

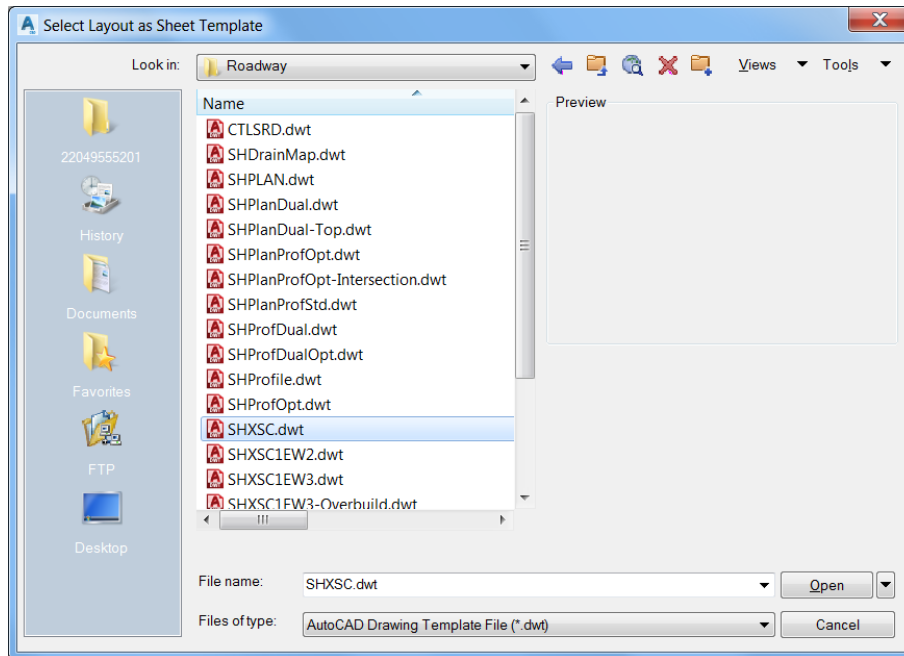

- From the Select Layout as Sheet Template dialog, from the Select a layout to create new sheets list, select 40 Horiz x 10 Vert, then Click OK.

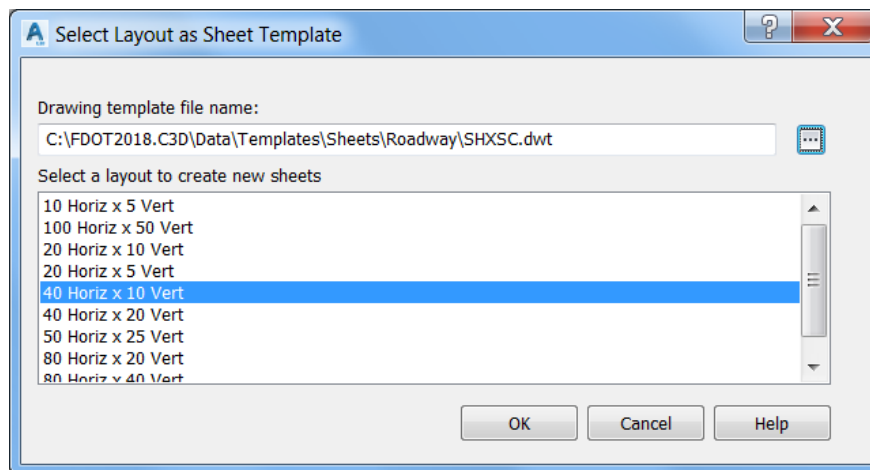

10. From Create Multiple Section Views - Section Placement dialog, Click Next>.

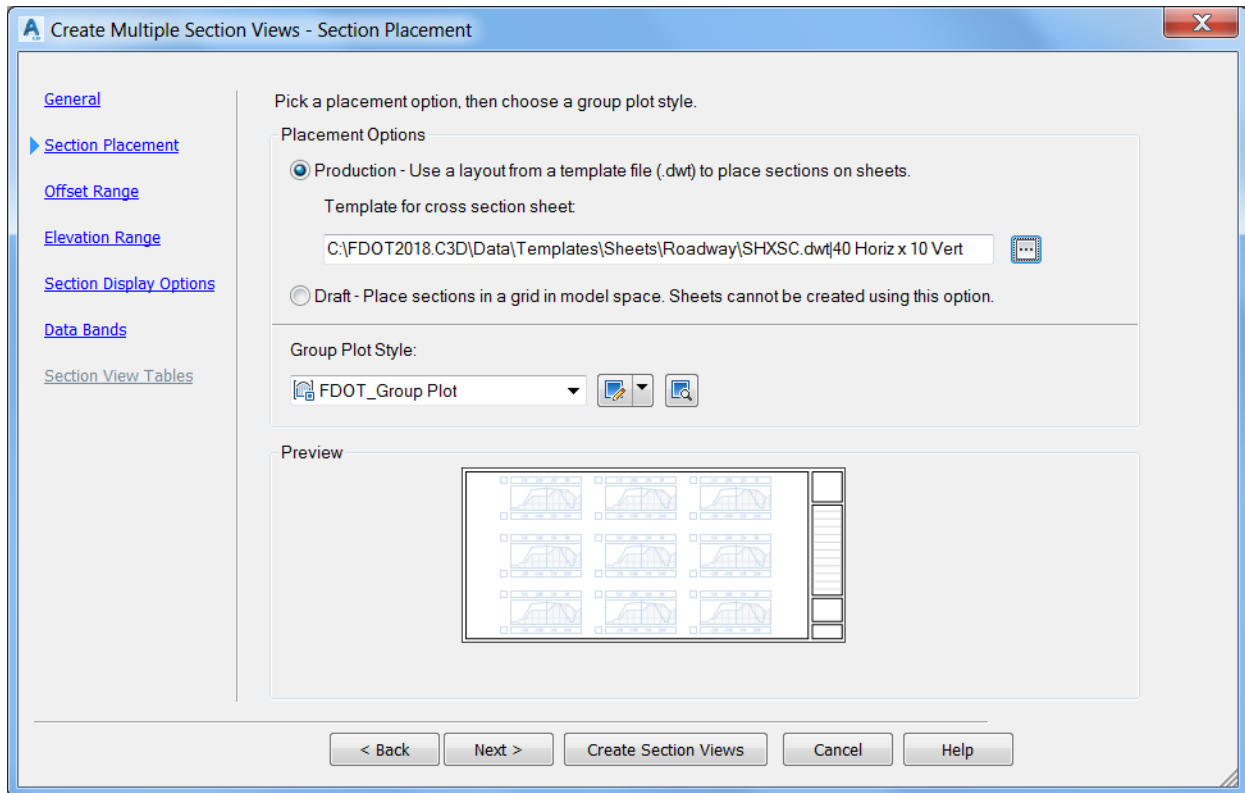

11. From Create Multiple Section Views - Offset Range dialog, click Next >

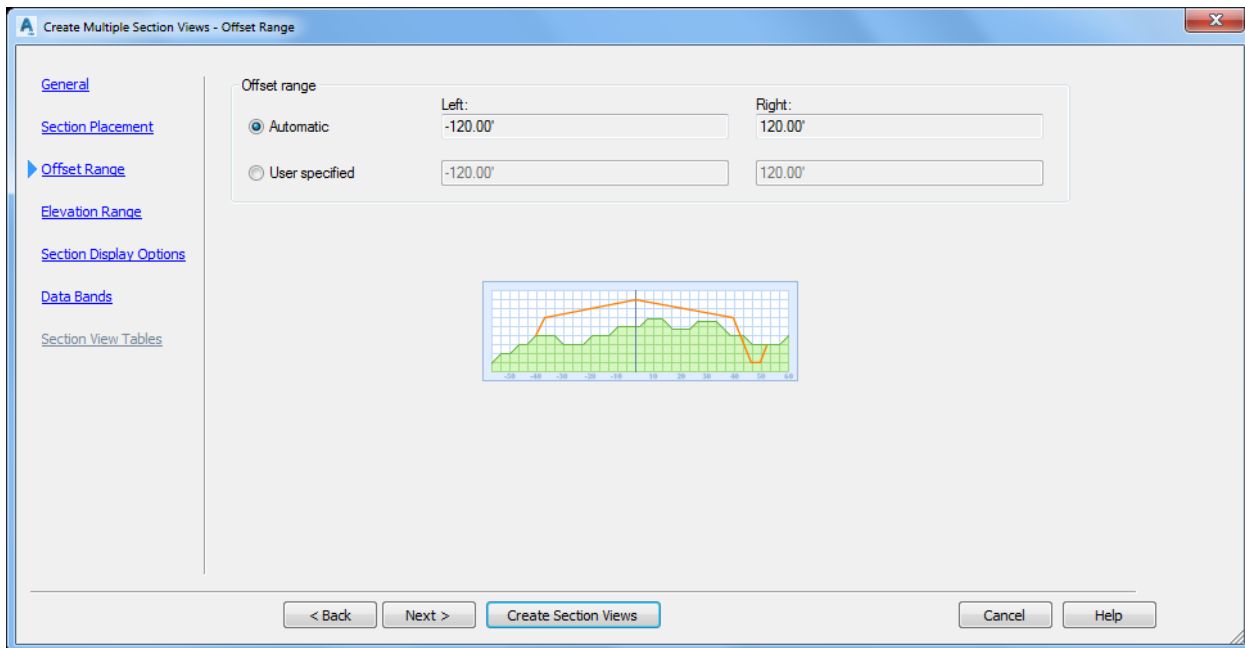

12. From Create Multiple Section Views - Elevation Range dialog, click Next >

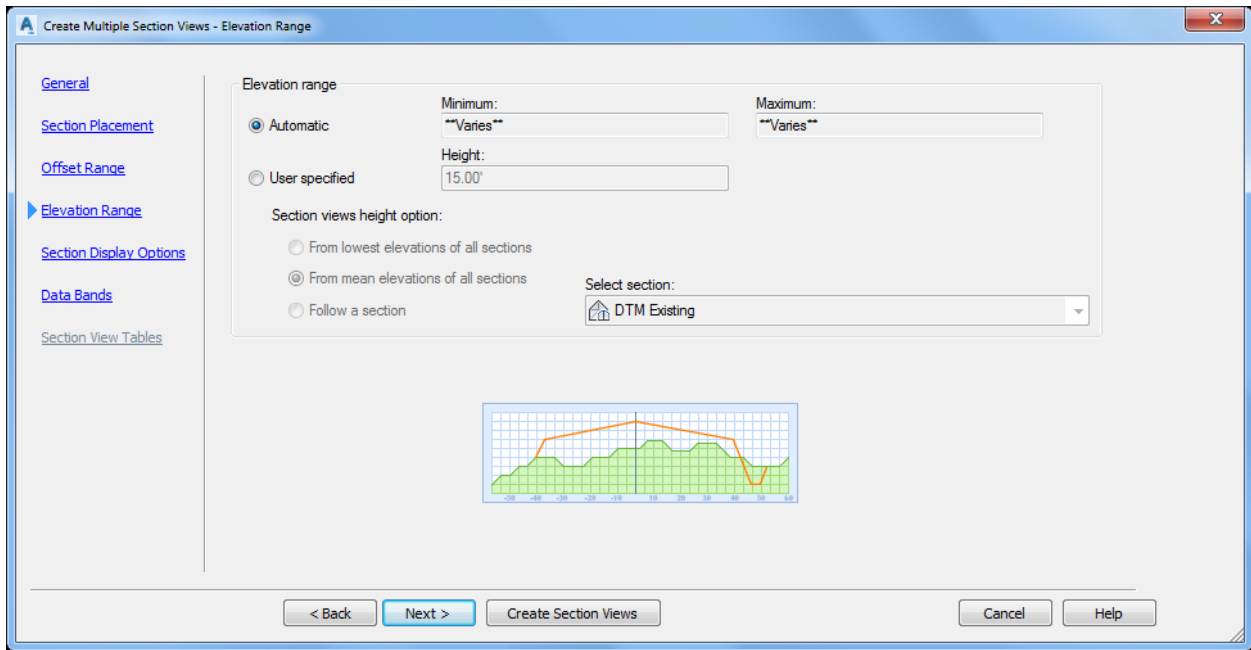

13. From Create Multiple Section Views - Section Display Options dialog, set the Style for DTM Existing to: FDOT Existing, Set the Style for SR61 - Existing Conditions to: FDOT XSection Existing, then click Next >

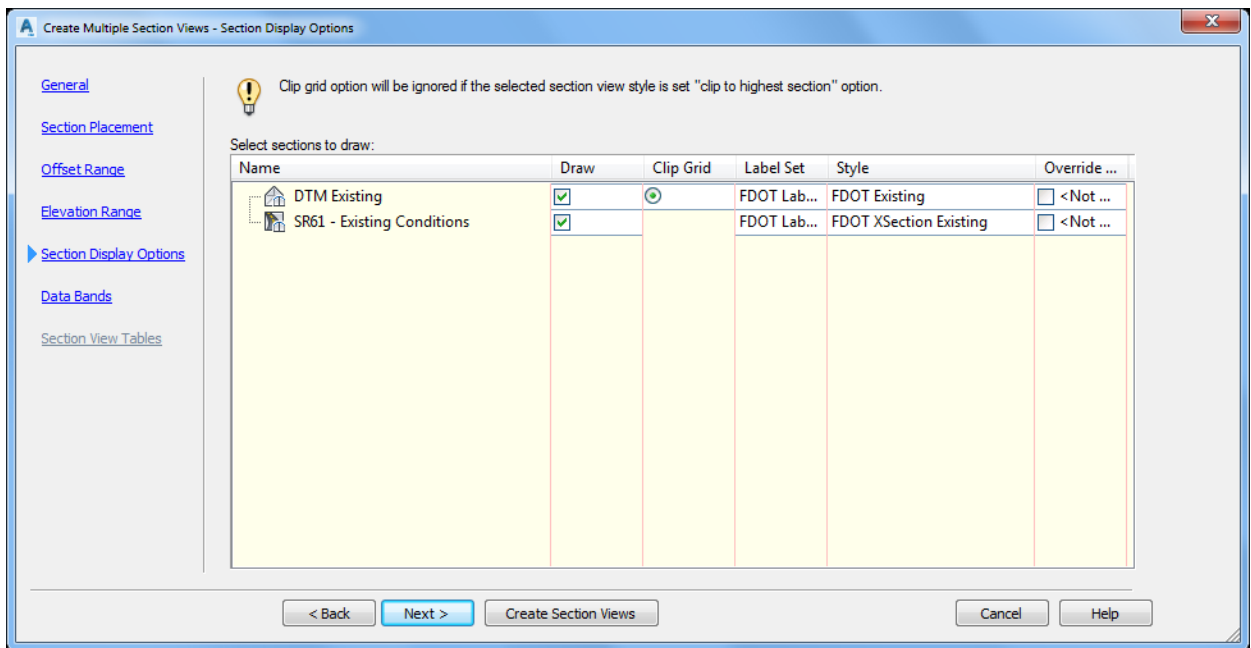

14. From Create Multiple Section Views - Data Bands dialog, Click Create Section Views.

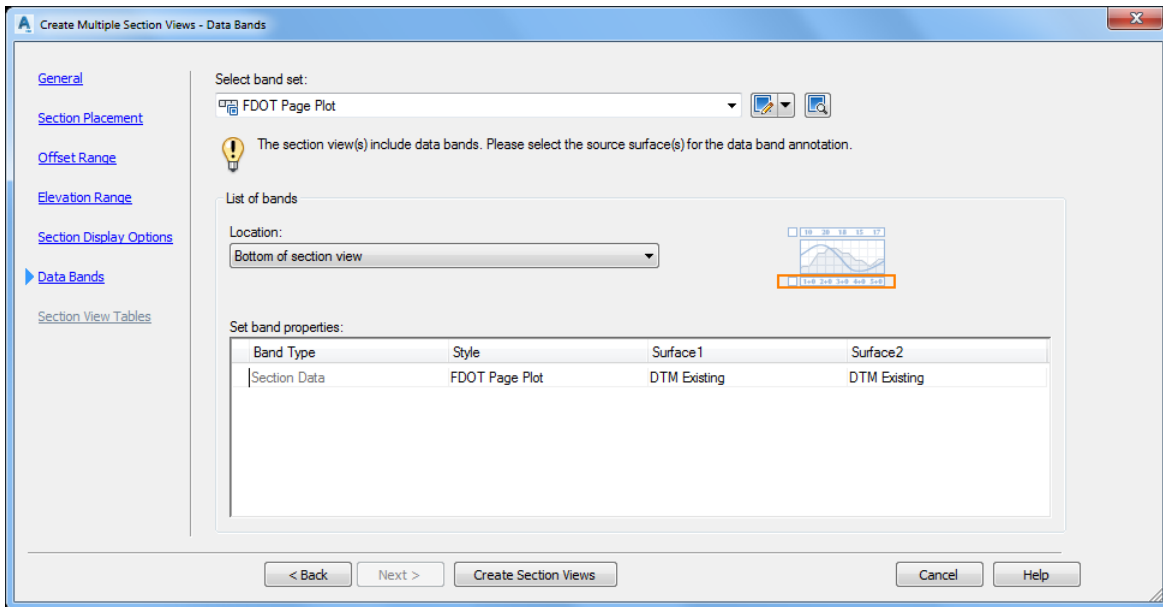

15. Place the Sections above the SR61 Profile View

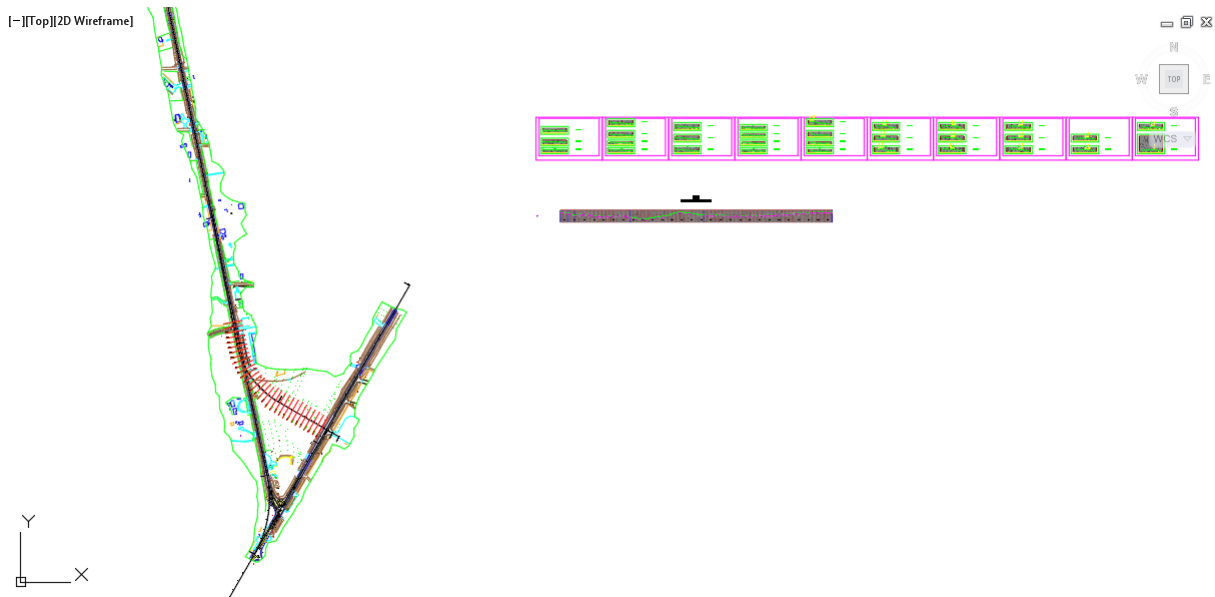

16. Perform a **Zoom Window**, to review results at Station 709+00.00

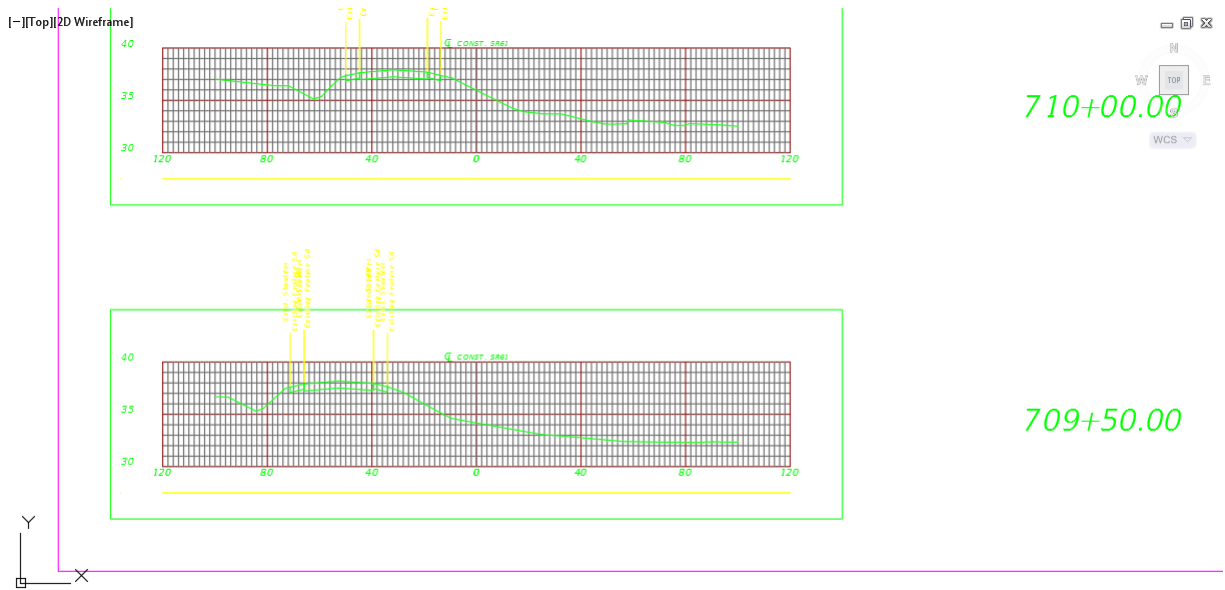

17. Perform a Zoom Window to display the 22049555201 project location, the SR61 Profile View, and the Section Views.



18. **Save** and **Close** the MODLRD01-Existing Conditions.dwg file

7 Create CORRIDOR MODEL

DESCRIPTION

In this Chapter you will create and edit a corridor model. The process is completed in three stages of increasing complexity. To prepare the objects controlling the horizontal and vertical position of the design you will offset alignments and their corresponding design profiles. You will create an assembly as required before creating the corridor model for the first pass. You will edit the assembly and assign targets within a corridor region for the second and third passes.

OBJECTIVES

In this chapter you will:

- Create an alignment using the alignment offset command.
- Create an offset profile.
- Create and edit an assembly.
- Modify subassembly parameters.
- Create and edit a corridor model.
- Assign edge of pavement alignments as target geometry.
- Review the results after each pass.

CHAPTER SETUP

Run the Chapter 7 - 22049555201.exe file and restore all files to the C:\Civil 3D 20XX Projects folder.

Do not change the location in which the Practice Files are installed. Doing so can cause errors when completing the exercises in this training manual.

Exercise 7.1 Create MODLRD02.dwg

In this exercise you will create the MODLRD02 file to be used to create a Corridor Model.

1. From the **Select File** dialog box, navigate to the *C:\Civil 3D 2017 Projects\22049555201\Roadway* folder and select **7.1 – Corridor Model - Lanes - Start.dwg**. Click **Open**.
2. Right click the drawing tab and click **Save As**. From the **Save Drawing As** dialog box, navigate to the *C:\Civil 3D 2017 Projects\22049555201\Roadway* folder and type **MODLRD02.dwg** for the File name. Click **Save**.

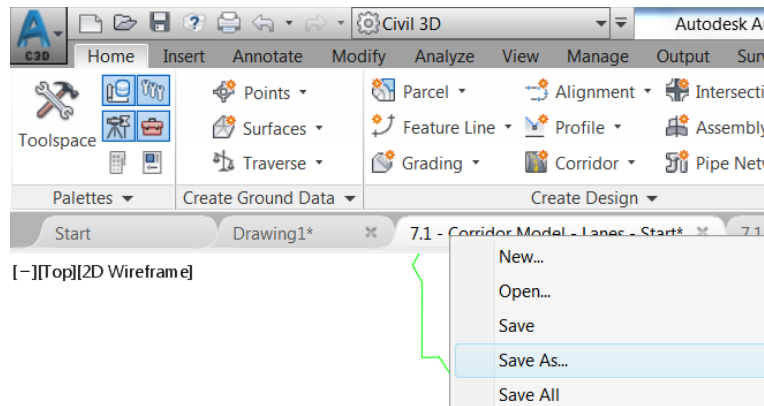

3. Associate MODLRD02.dwg File to the Project. From the *TOOLSPACE > Prospector tab > Data Shortcuts* [C:\Civil 3D 2017 Projects\22049555201], right-click and select **Associate Project to Current Drawing**.

Exercise 7.2 Create offset alignments and offset profiles

The MODLRD02.dwg contains an alignment and a profile for SR61. The typical section shows the PGL at the through lane which is offset from the centerline by 11 feet left and right. To model the through lanes of SR61 create offset alignments and transfer the elevation of the PGL to the offset profile.

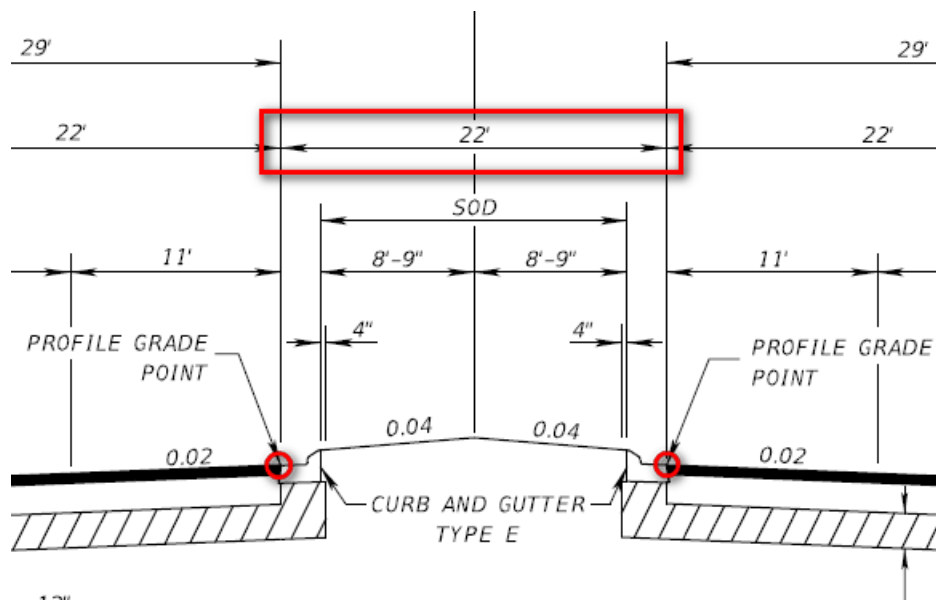

➤ **To create the PGL geometry and profile use the Create Offset Alignment command.**

1. Click the Create Offset Alignment command from the Home tab > Create Design panel on the ribbon.

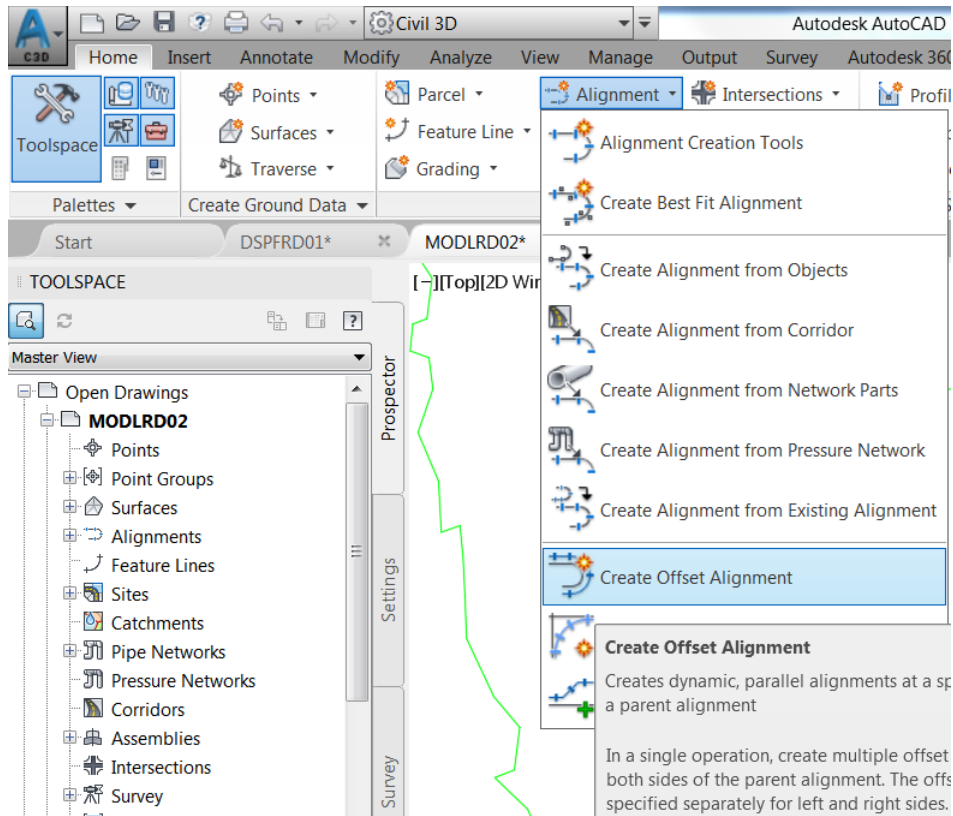

- Pick the SR61 alignment. In the Create Offset Alignment dialog set the Incremental offset on left: to 11.00' and set the Incremental offset on right: to 11.00'. Continue by clicking the Create Offset Profile tab.

Create Offset Alignments

Alignment to offset from:
SR61

Offsets name template:
<[Parent Alignment Name(CP)]>-<[Side]>-<[Offset Distance:]>

Station range

From start To end

698+53.79' 726+41.79'

No. of offsets on left: No. of offsets on right:
1 1

Incremental offset on left: Incremental offset on right:
11.00' 11.00'

General Widening Criteria Create Offset Profile

Site:
<None>

Alignment style:
FDOT Proposed

Alignment layer:
CLConst_dp

Alignment label set:
<_No Labels>

OK Cancel Help

- On the Create Offset Profile tab match the following settings. Create profile for offset alignment is checked. The Parent profile is set to SR61-PGL from the drop-down list. Superimpose onto profile view: is set to SR6127+88.00 from the drop down list. The Cross slope from parent profile: is set to 0. The Profile style is set to FDOT PGL Right. Click OK.

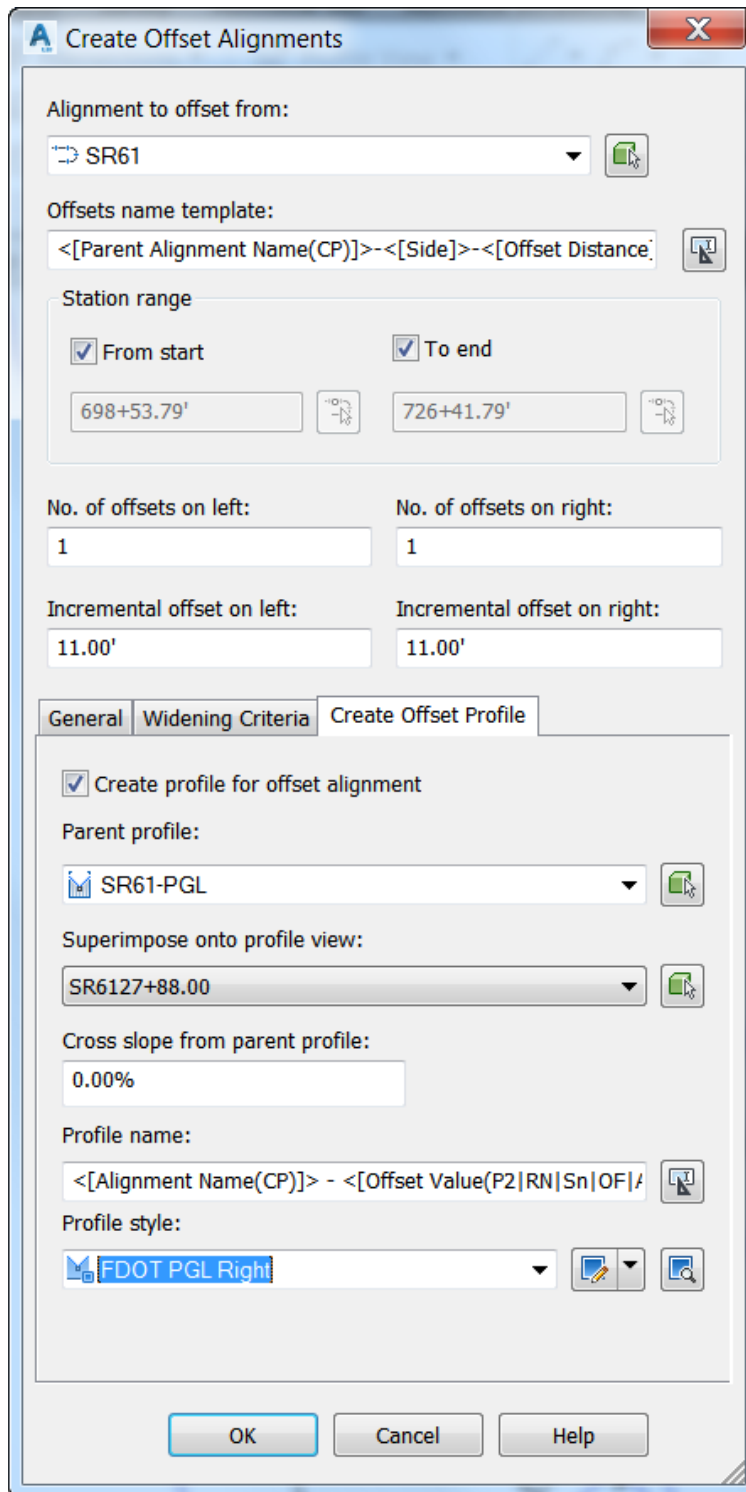

4. The offset alignments are added to the model. In the Prospector the new alignments are found under the Offset Alignments collection with the following names.
 - SR61-Left-11.00
 - SR61-Right-11.00

The profiles for each offset alignment have the following names.

- SR61-Left-11.00 - -11.000
- SR61-Right-11.00 - -11.000

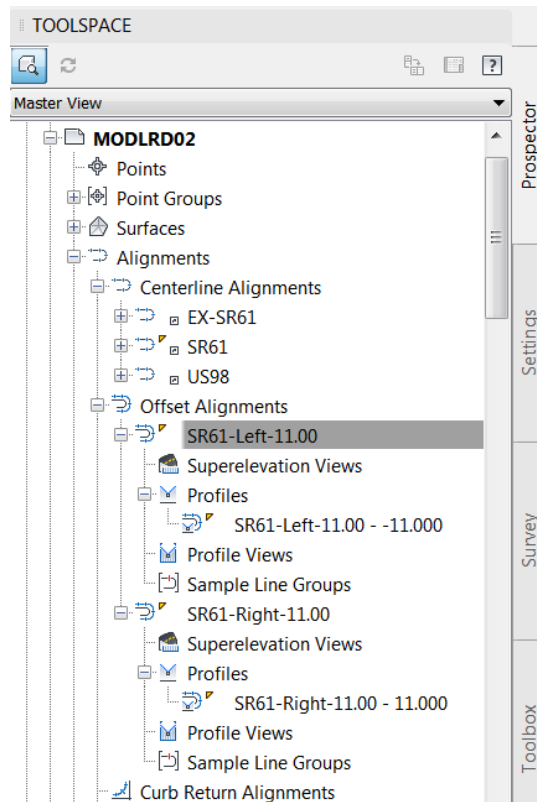

5. Right click on the offset profile SR61-Left-11.00 - -11.000 and select the Properties command.

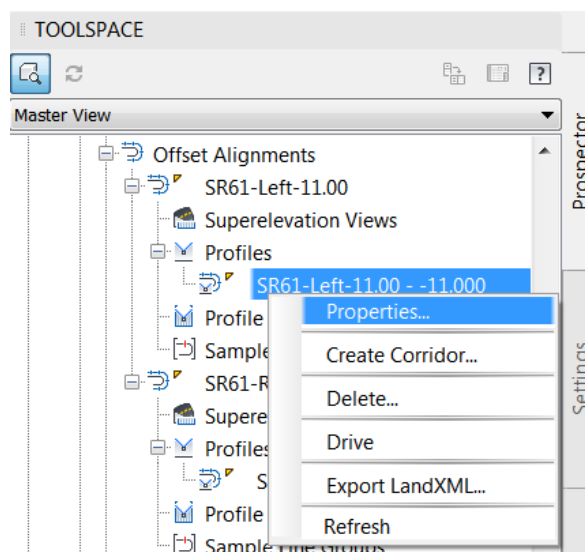

- In the Profile Properties dialog > Information tab set the Object style to FDOT PGL Left. Click the Offset Parameters tab.

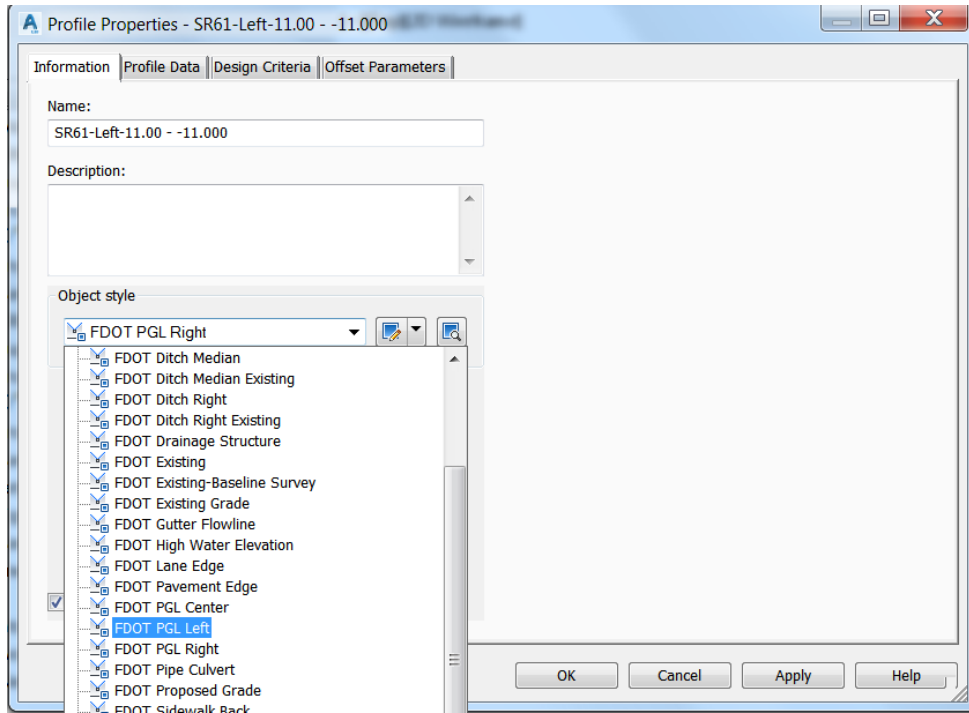

- On the Offset Parameters tab you can add station and slope values to the Cross slope regions area. For this alignment the cross slope will remain at zero for the entire length in order to match the elevations at the PGL. Click OK.

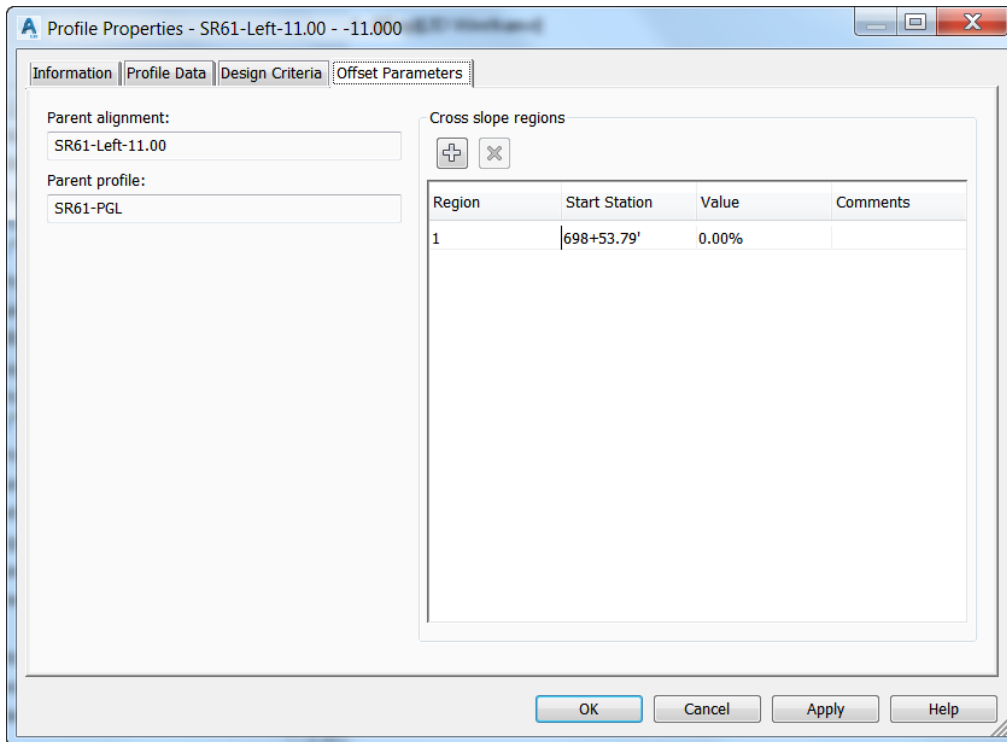

8. Left and right profiles are added to the SR61 collection of profiles as superimposed profiles.

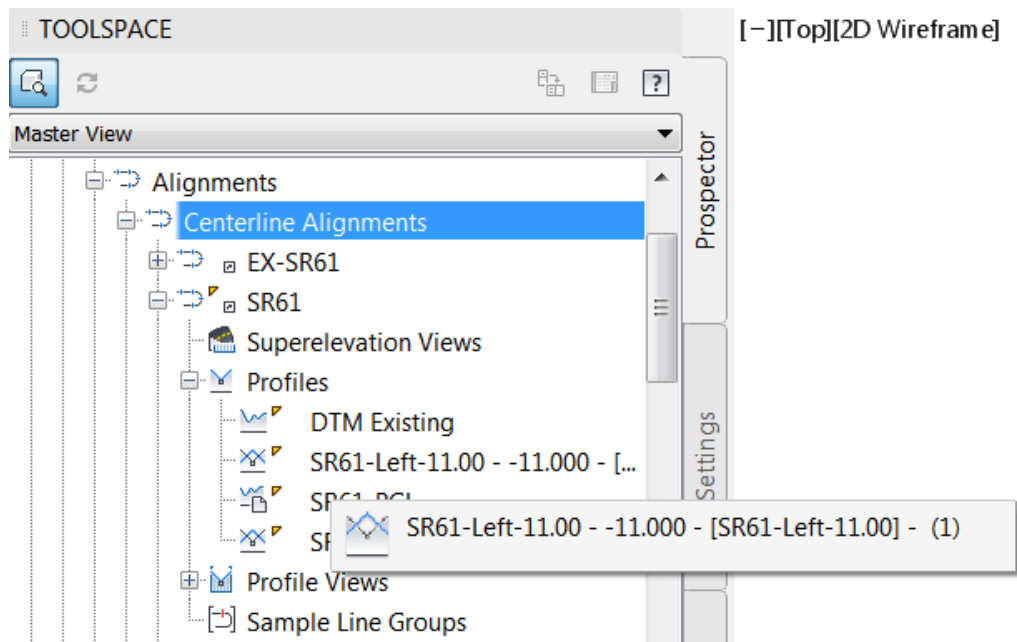

9. There are 4 different profile icons in the Prospector; Surface Profile, Superimposed Profile, Layout Profile, Offset Profile.

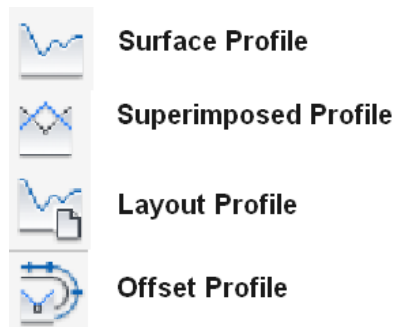

- Superimposed profiles are added to the SR61 Profiles collection. Right click the SR61-Left-11.00 - ...profile and click Properties.

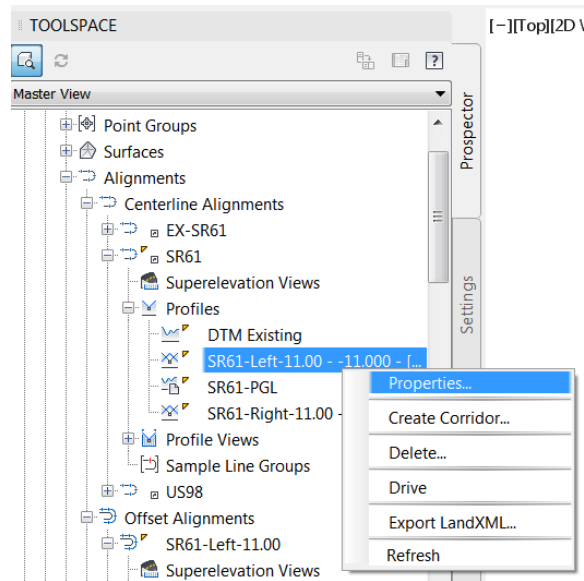

- Click the Profile Data tab. Notice under the Data Source heading is the offset alignment, SR61-Left-11.00 - -11.000 the parent object of this profile. Superimposing the offset profiles is a convenient way to view the PGL and offset profiles in one profile view. Click OK.

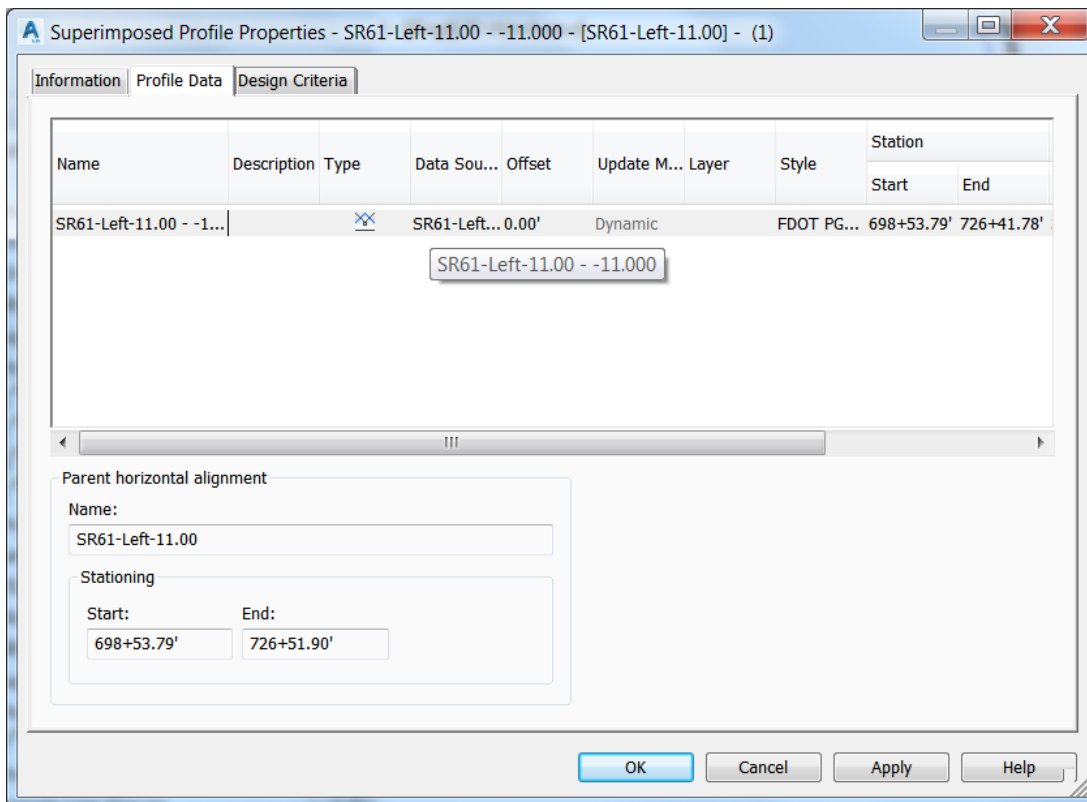

- Object names have a tendency to become verbose. Take a moment to cleanup the profile names in the Prospector replacing the existing names with those shown in red below. To edit a profile name right click on the profile name in the Prospector and click Properties.

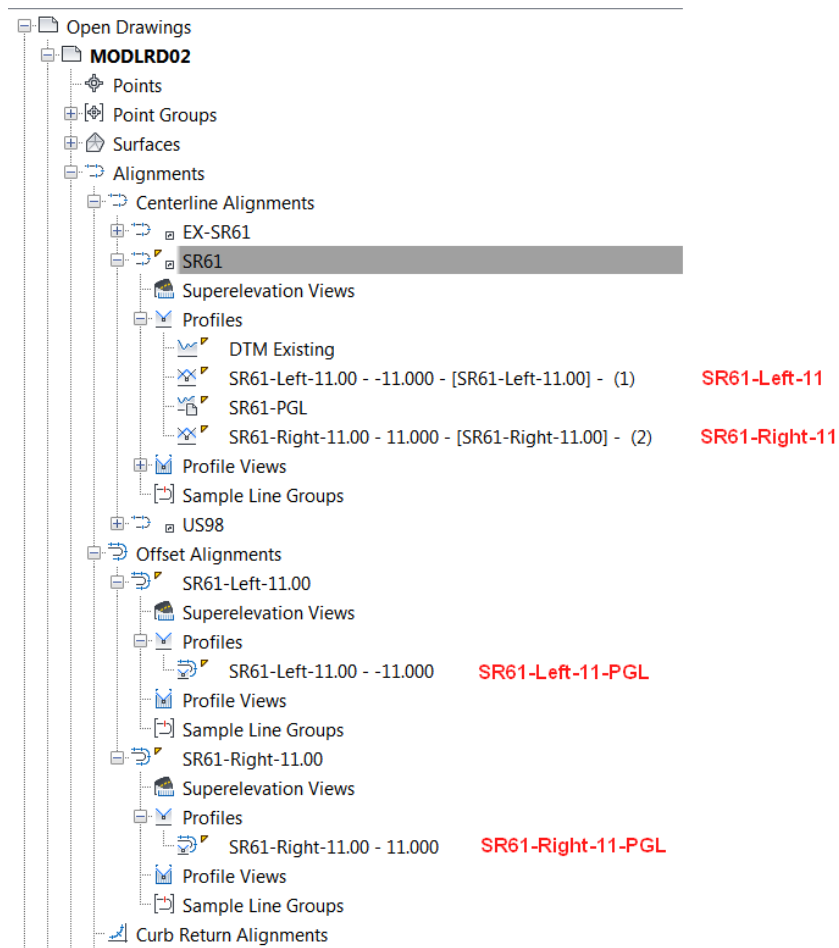

- The end result from renaming the profiles is shown below.

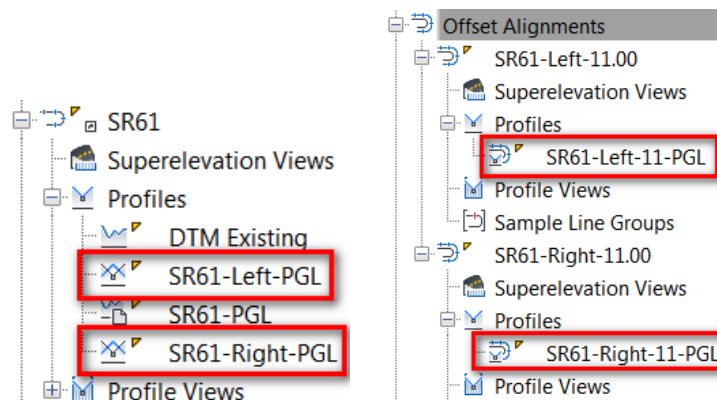

- Save** your file before continuing.

Exercise 7.3 *Creating a Corridor Model - First Pass – Through Lane*

Witness the workflow of creating a corridor model starting with a simple through lane example. This example demonstrates the sequence of steps required to create a corridor model in a concise manner. As the corridor model becomes more complex and more subassemblies are added the behavior of each subassembly is revealed one at a time to build your knowledge incrementally. A corridor model requires three objects, an alignment, a profile, and an assembly. The Create Corridor command processes these three objects to produce a corridor model.

1. Click the Create Assembly command on the Home tab > Create Design panel under the Assembly button. In the Name: field type SR61-Right. Click OK.

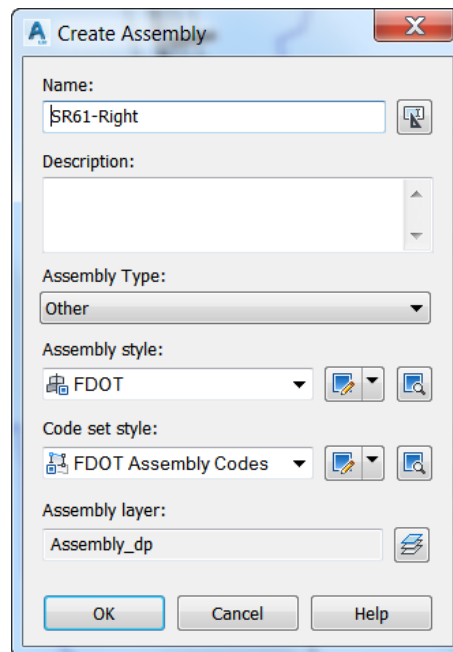
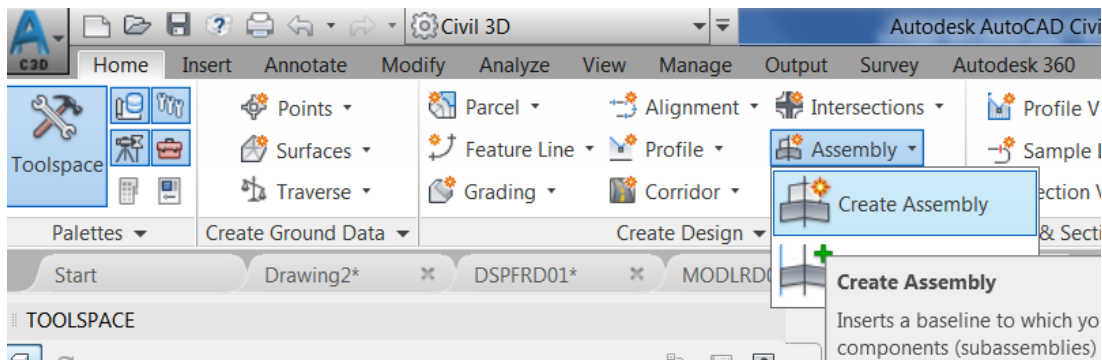

- 2. Pick the Center of the circle labeled Assemblies as shown below.

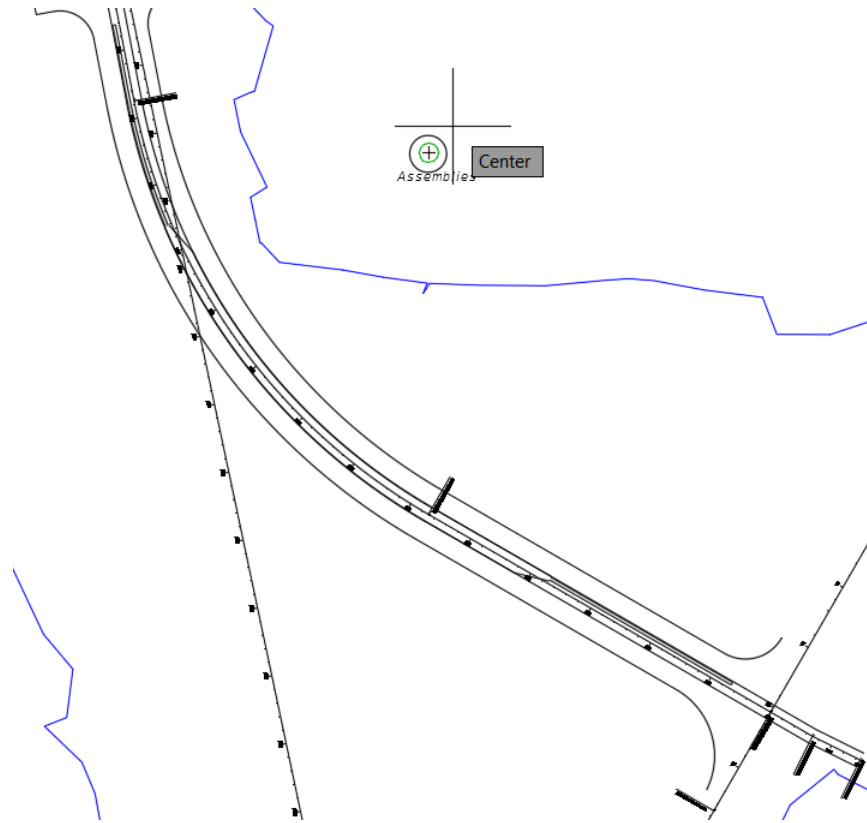

- 3. The Assembly Marker is placed at the center of the circle. The Assembly Marker represents the location that the Assembly is positioned horizontally along the alignment and vertically along the profile. The subassembly geometry extends perpendicular to the alignment.



- Subassemblies are attached to an Assembly to represent a typical cross section of the components of a road design. Subassemblies are organized on Tool Palettes. In this example you pick the FDOT Lane subassembly and add it to the Assembly Marker. Click the Tool Palettes button on the Home tab > Palettes panel. The Tool Palettes are anchored on the right side of your screen. Click the Lanes - FDOT tab.

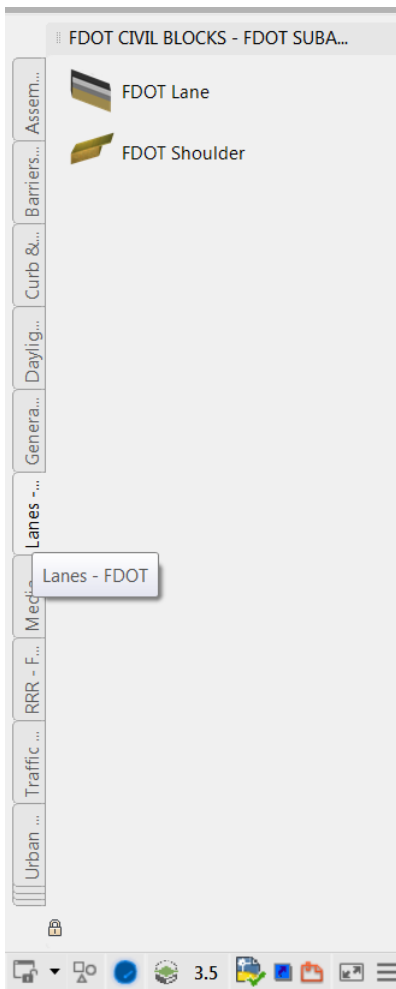
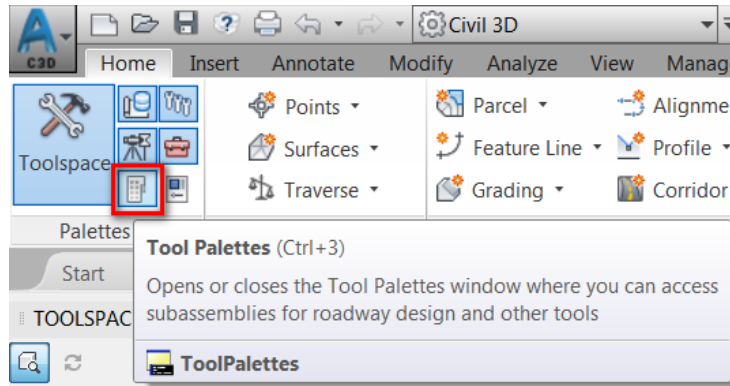

- Click FDOT Lane on the Lanes – FDOT tab. The Properties Palette displays allowing you to edit the Lane Width parameter as well as other parameters. Type 11.00 for the Lane Width and press Enter.

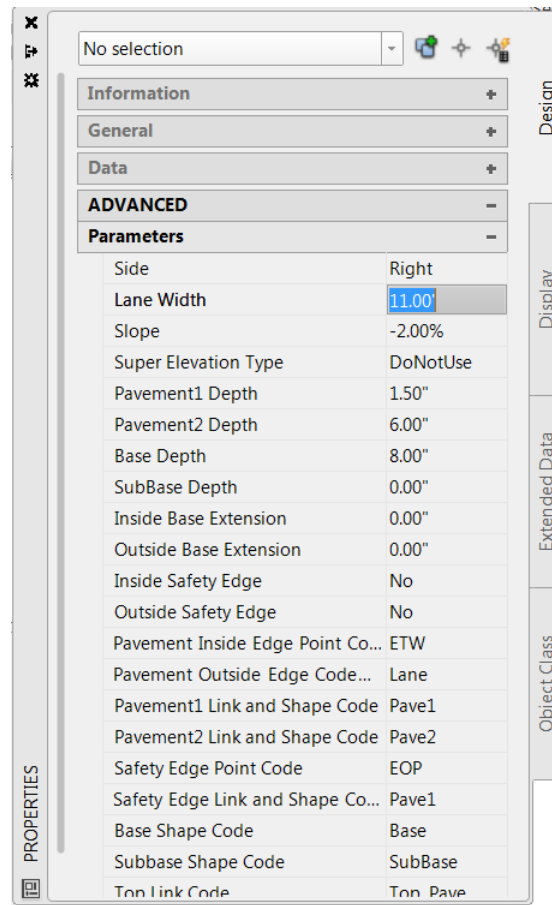

- Pick the Assembly Marker using the pickbox on your cursor. The Lane subassembly is attached to the SR61-Right assembly. Press ESC to end the command.

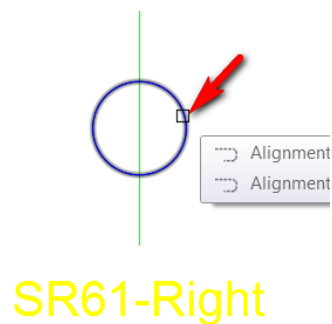

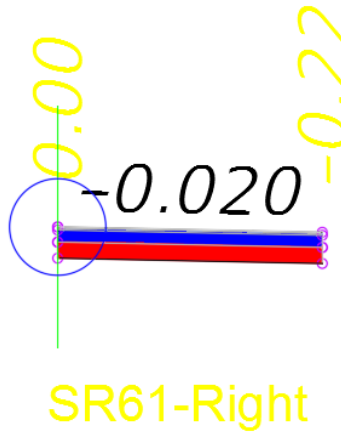

7. Click the Corridor command under the Home tab > Create Design panel > Corridor button.

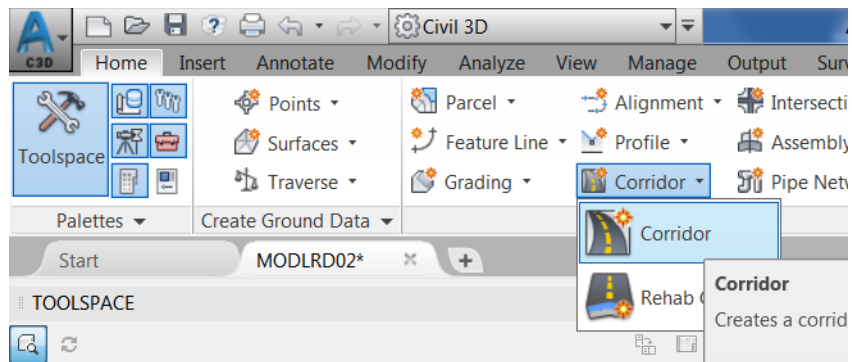

8. Enter the Name: SR61-Right. Select the SR61-Right-11.00 alignment. Select the SR61-Right-11-PGL profile. Select the SR61-Right assembly. Click OK.

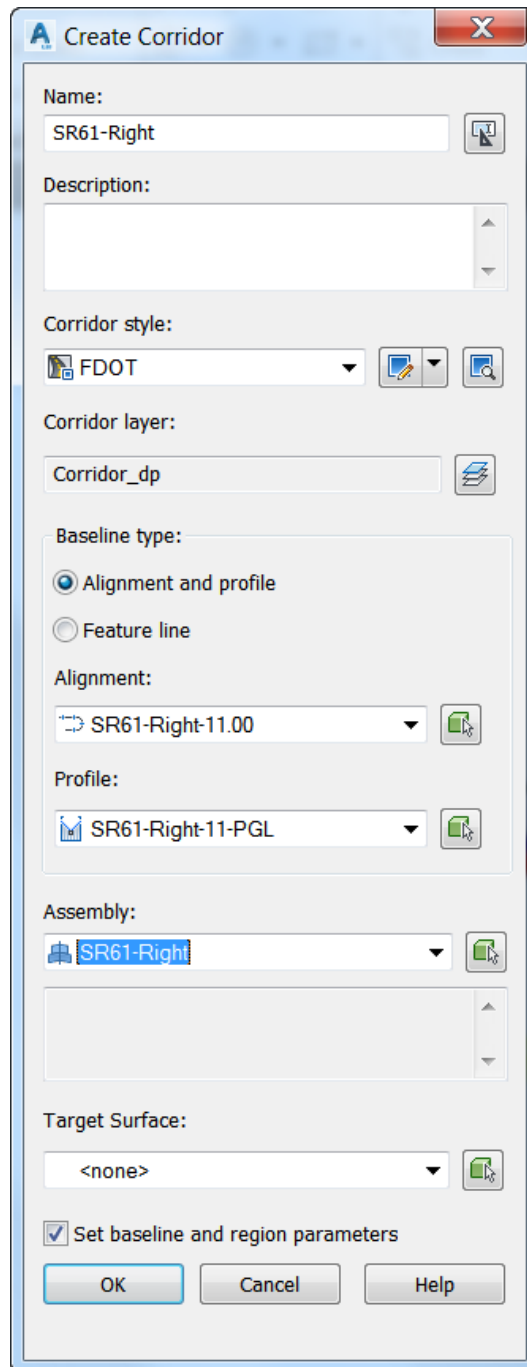

The 'Create Corridor' dialog box is shown with the following settings:

- Name:** SR61-Right
- Description:** (Empty text area)
- Corridor style:** FDOT
- Corridor layer:** Corridor_dp
- Baseline type:** Alignment and profile (selected), Feature line (unselected)
- Alignment:** SR61-Right-11.00
- Profile:** SR61-Right-11-PGL
- Assembly:** SR61-Right
- Target Surface:** <none>
- Set baseline and region parameters

Buttons at the bottom: OK, Cancel, Help

- The Baseline and Region Parameters dialog box organizes the display of the objects you selected to make the corridor. The first row contains the Baseline information meaning, the alignment, the profile, and the Starting and Ending Stations. The second row represents the first Region. The Region is nothing more than a station range between a starting and ending station typically representing something less than the full length of the Baseline alignment. There can be more than one Region under the Baseline. Regions can not have overlapping station ranges. An explanation of Frequency and Targets will come later in this training guide. Click OK. Click Rebuild the corridor.

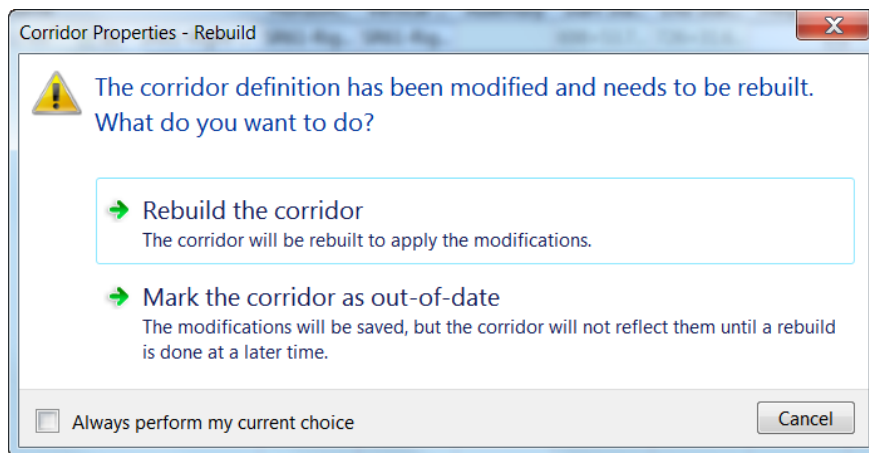
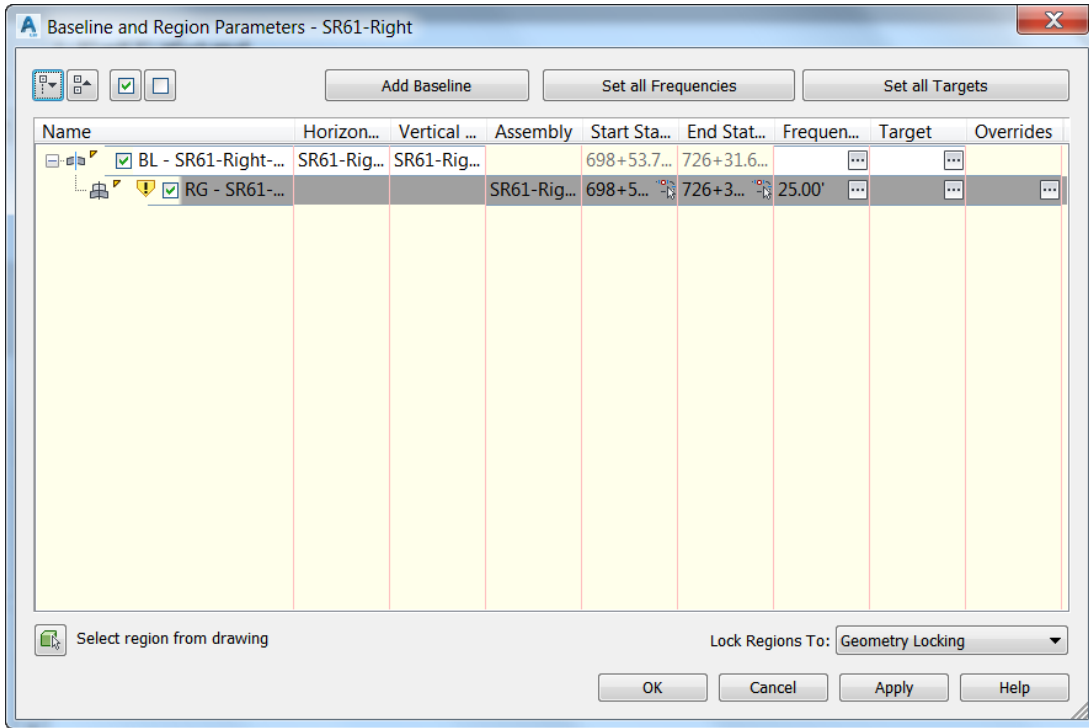

10. This drawing has named views. Pick the control in the canvas in the upper left corner labeled Top. Hover over Custom Model Views. Click Plan to restore the Plan view.

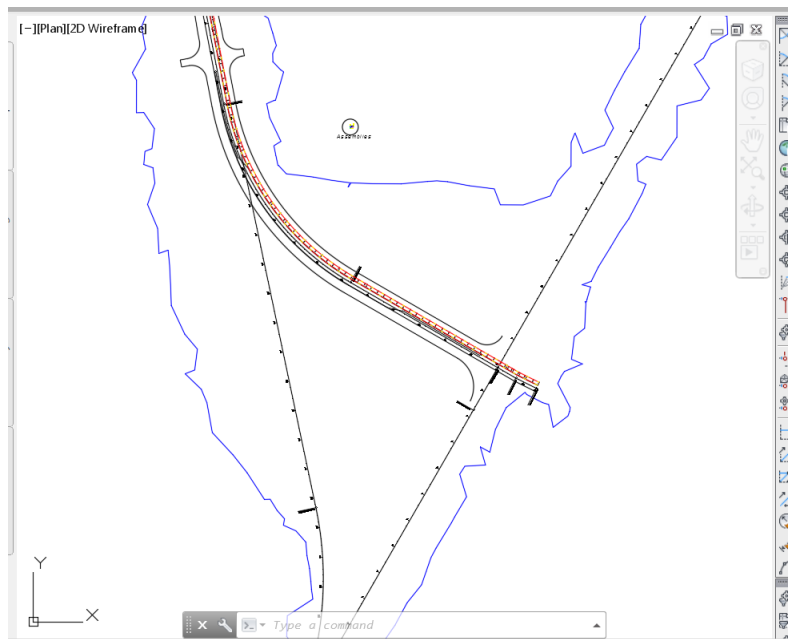
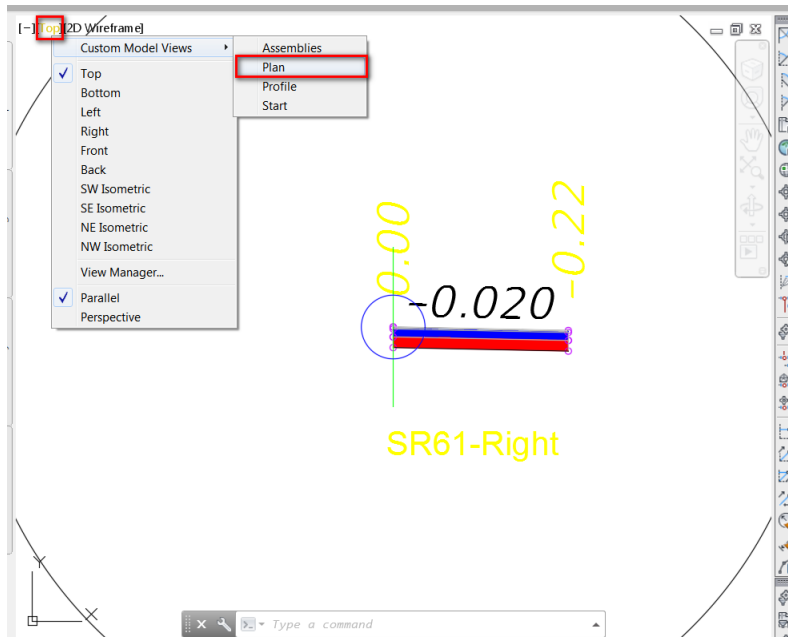

- Zoom in to station 704. Hover the crosshairs over the corridor model to display the tooltip. The lines perpendicular to the alignment identified as Corridor - Link are also referred to as frequency lines. The lines parallel with the alignment are corridor feature lines that connect the point codes from one station to the next. The Lane subassembly is applied to the SR61-Right baseline (alignment) at 25' intervals. In Plan view they look like lines. Notice the SR61 alignment labels have tick marks at 20' intervals. The Lane subassembly Lane Width parameter is set to 11' and applied to the right side of the baseline at a slope of -2%.

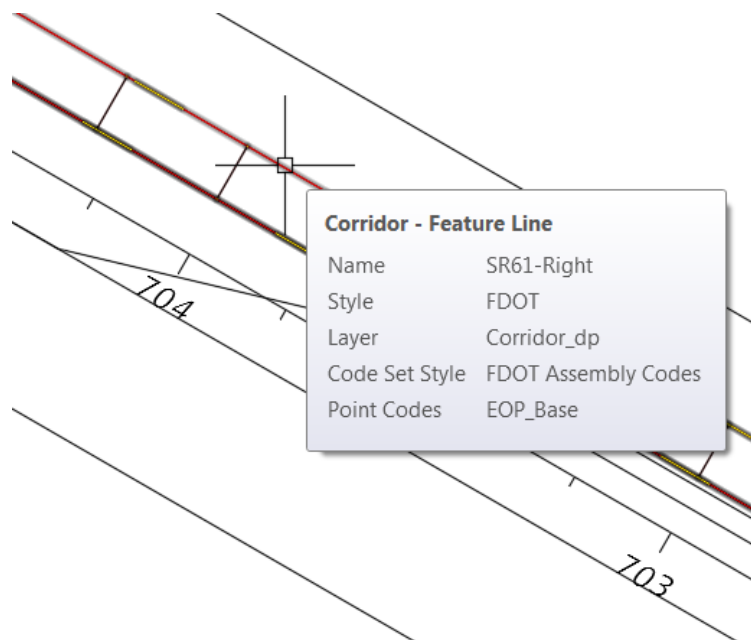
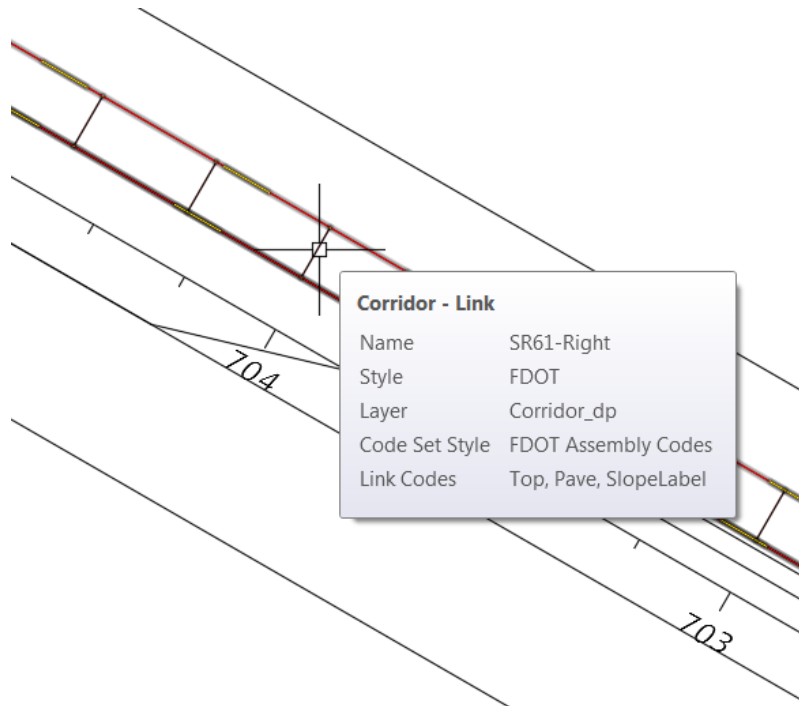

12. Restore the SE Isometric view. Zoom to station 704. The blue and red geometry represents the pavement, base and subbase material of the Lane subassembly in a 3D view. This ladder-like geometry is a corridor model. Essentially, a corridor model is a typical cross section applied at intervals along an alignment at the elevation of the profile. Restore the Plan view. Save the drawing.

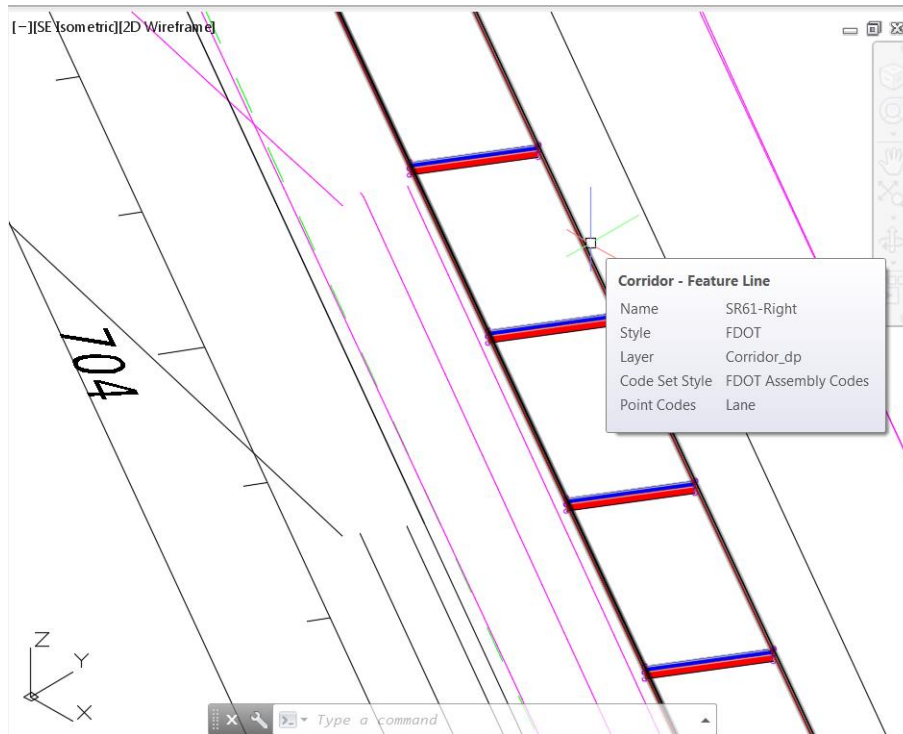

Exercise 7.4 *Corridor Model – Second Pass – Curb, Sidewalk, and EOP Target*

Continuing with the SR61-Right corridor model add more subassemblies and assign a target to control the horizontal position of the outside Edge of Pavement.

1. Restore the Assemblies view. Click the Curb tab on the Tool Palette. Click the Type F curb. Set the Side to Right in the Properties palette. Zoom into the SR61-Right assembly and pick the upper right circle on the Lane subassembly. Press ESC to end the command.

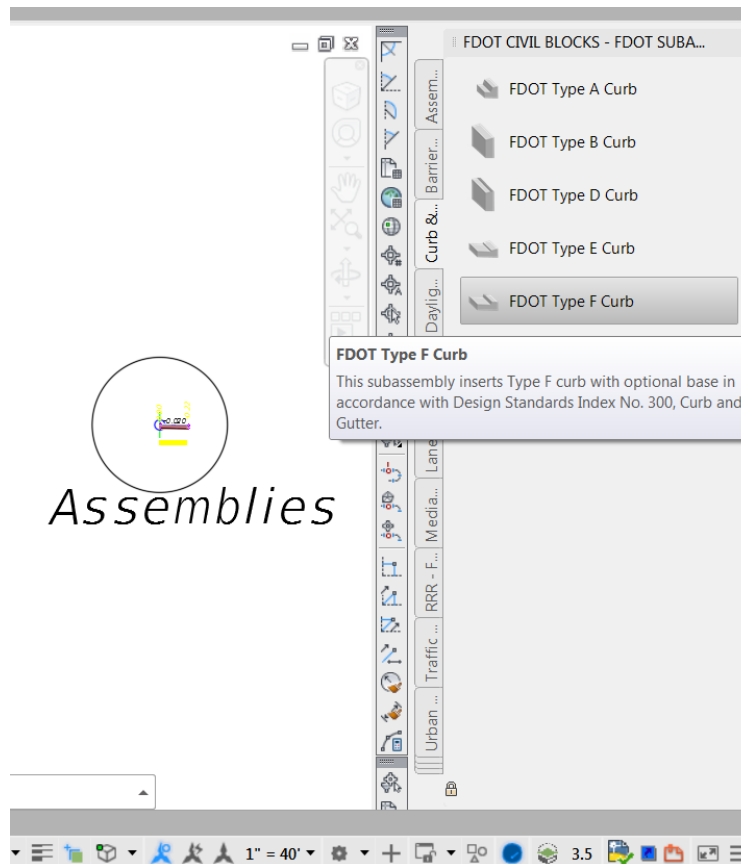

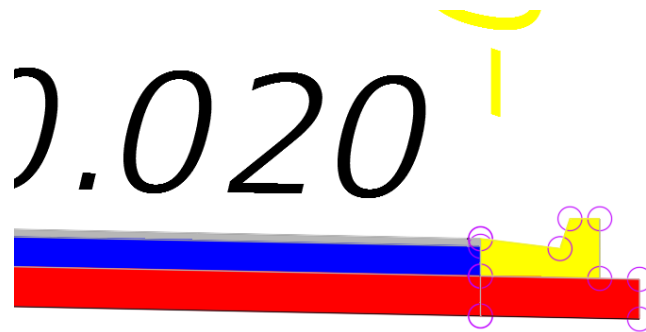
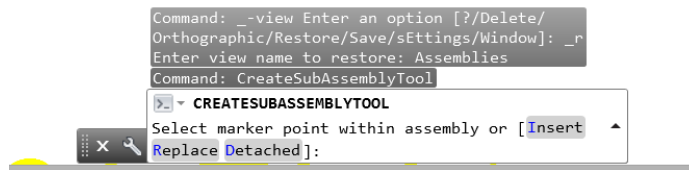
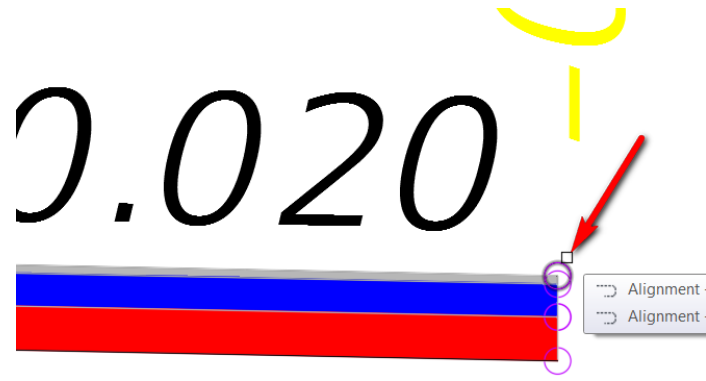

2. Click the Urban tab on the Tool Palette. Click the FDOT Sidewalk subassembly. Keep the default values in the Properties Palette. Pick the circle at the top back of curb on the Curb subassembly. Press ESC to end the command.

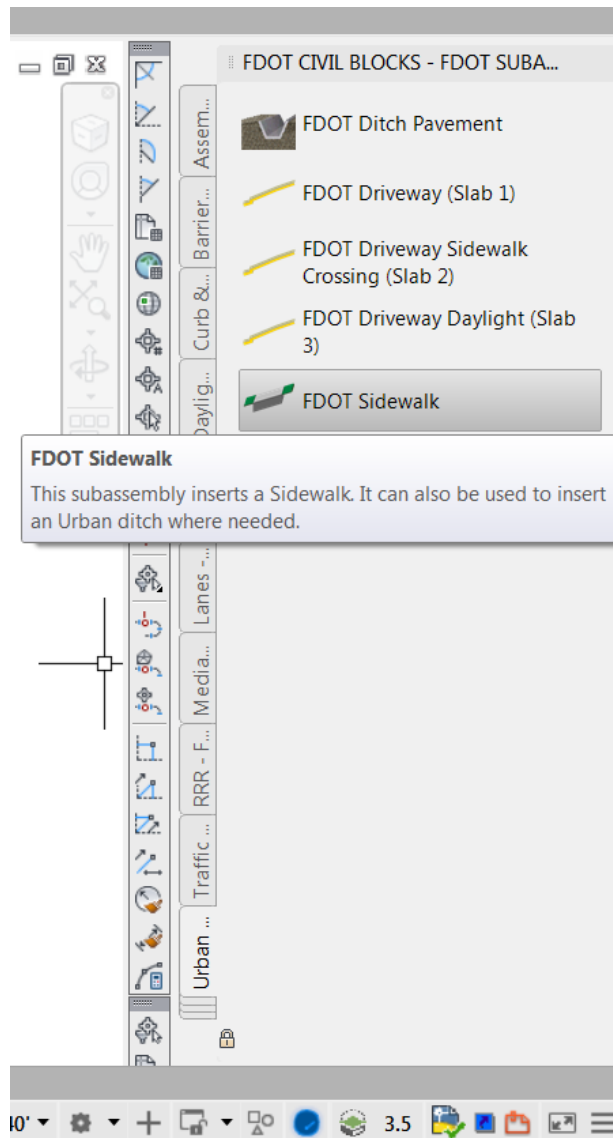

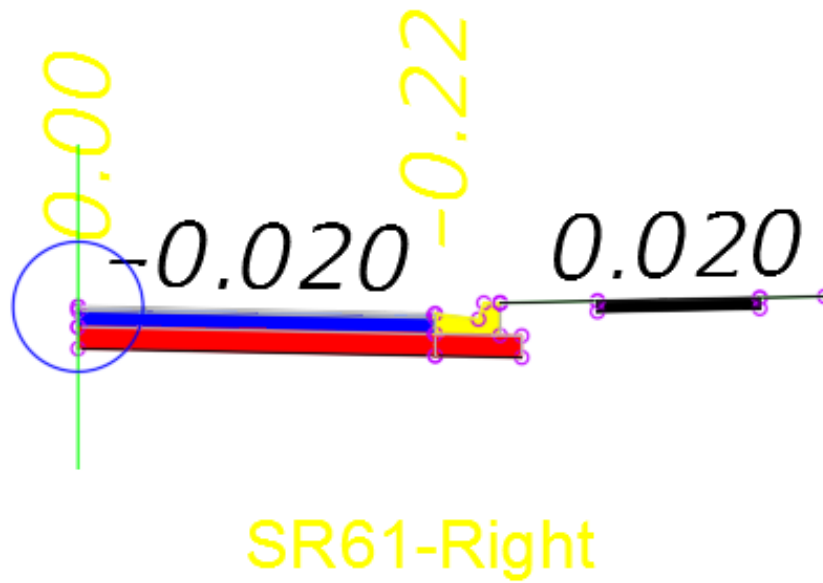
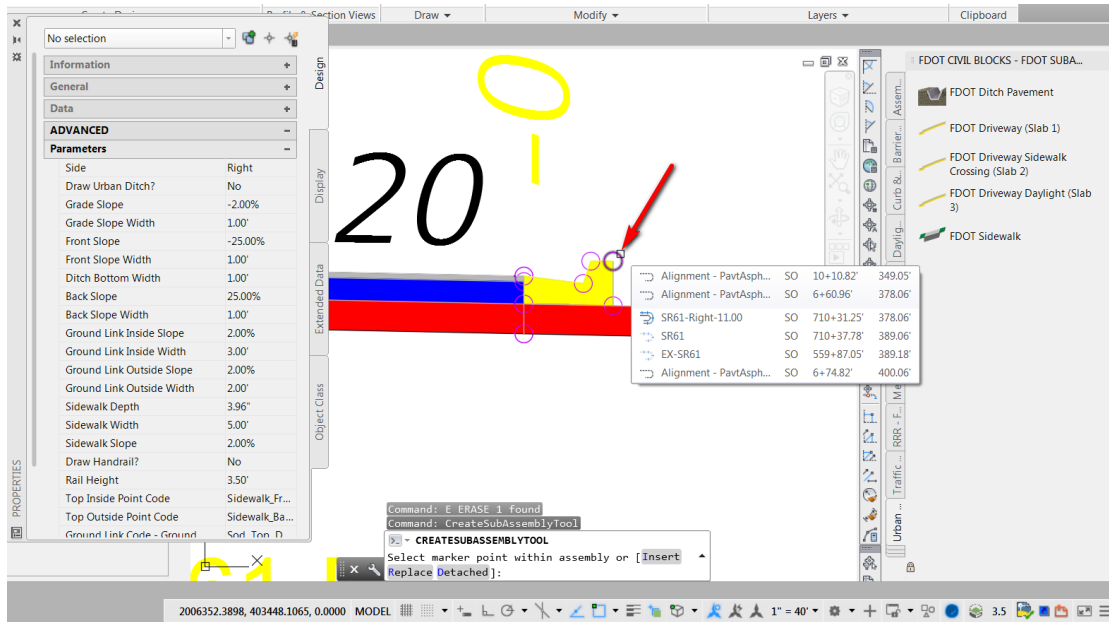

- Throughout the design process you will make changes to the subassembly parameters. Referring back to the Typical Section you notice the parameters for the Sidewalk subassembly do not match. Grip the Sidewalk subassembly and make changes on the Properties Palette.

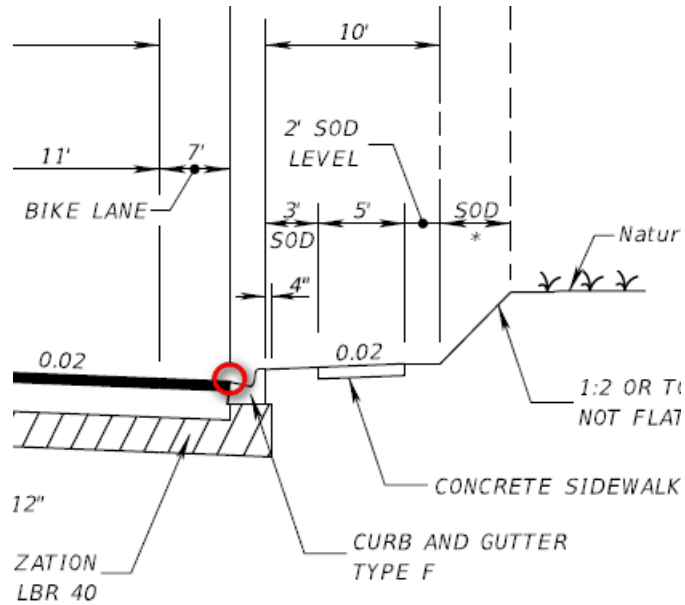

Properties palette for the Sidewalk subassembly. The 'ADVANCED Parameters' section is expanded, showing various settings. Several values are highlighted with red boxes:

Parameter	Value
Side	Right
Draw Urban Ditch?	No
Grade Slope	2.00%
Grade Slope Width	1.00'
Front Slope	-25.00%
Front Slope Width	1.00'
Ditch Bottom Width	1.00'
Back Slope	25.00%
Back Slope Width	1.00'
Ground Link Inside Slope	2.00%
Ground Link Inside Width	3.00'
Ground Link Outside Slo...	2.00%
Ground Link Outside Wi...	2.00'
Sidewalk Depth	3.96"
Sidewalk Width	5.00'
Sidewalk Slope	2.00%
Draw Handrail?	No
Rail Height	3.50'
Top Inside Point Code	Sidewalk_Front
Top Outside Point Code	Sidewalk_Back
Ground Link Code - Gro...	Sod. Top. Datum

- Assign a target parameter to the Lane Assembly to control the outside edge of pavement. Restore the Plan view and grip the corridor model. Click the Edit Targets command from the Modify Regions panel on the ribbon. Select a region to edit: appears as a command line prompt. Hover the cursor over the corridor to see the region perimeter highlighted in blue. Pick inside the region.

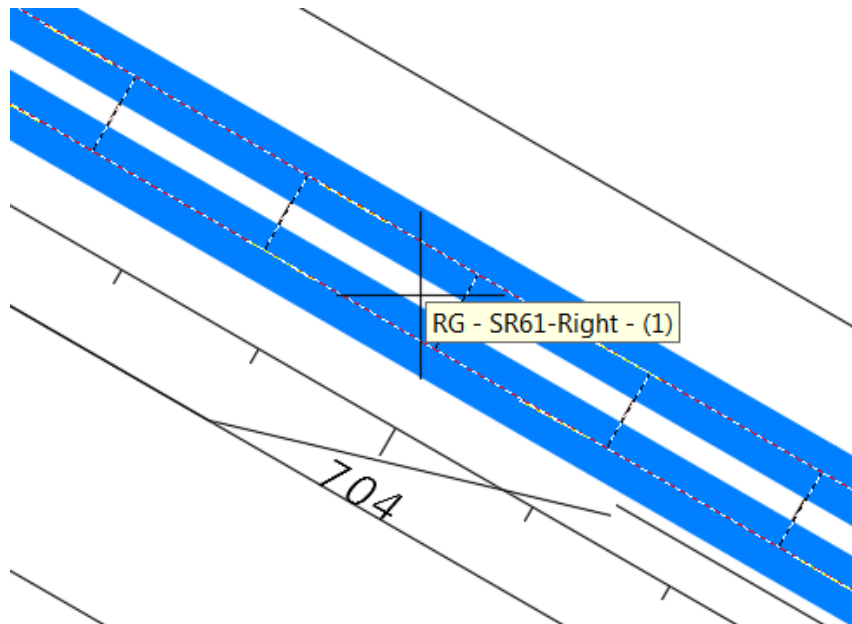
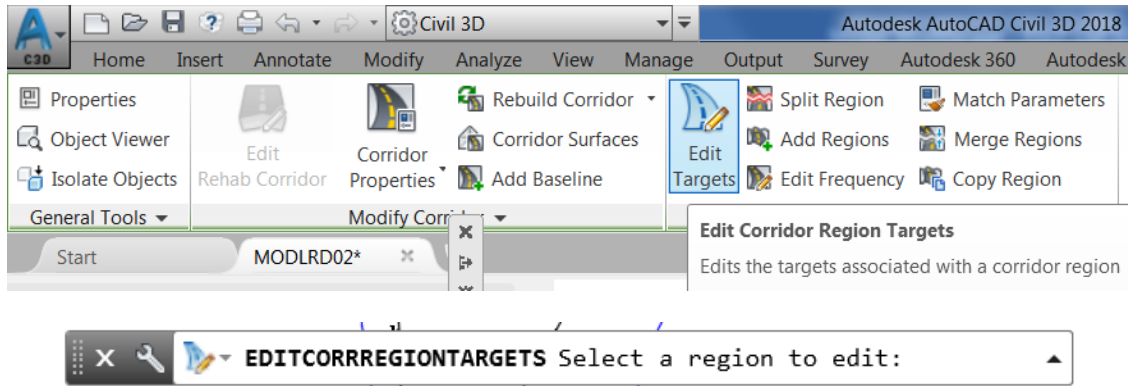

- In the Target Mapping dialog click the cell in the Object Name column on Lane Width row. In the Set Width Or Offset Target dialog select Alignment - PavtAsphalt RT then click the Add button. Click OK. Click OK again to close the Target Mapping dialog. Press ESC to end the Edit Targets command.

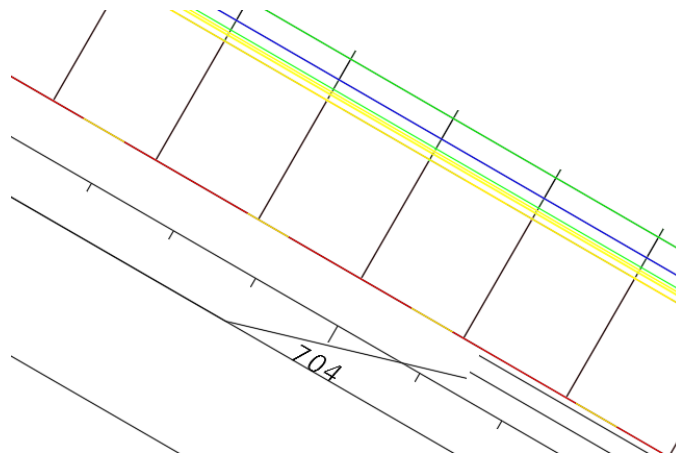
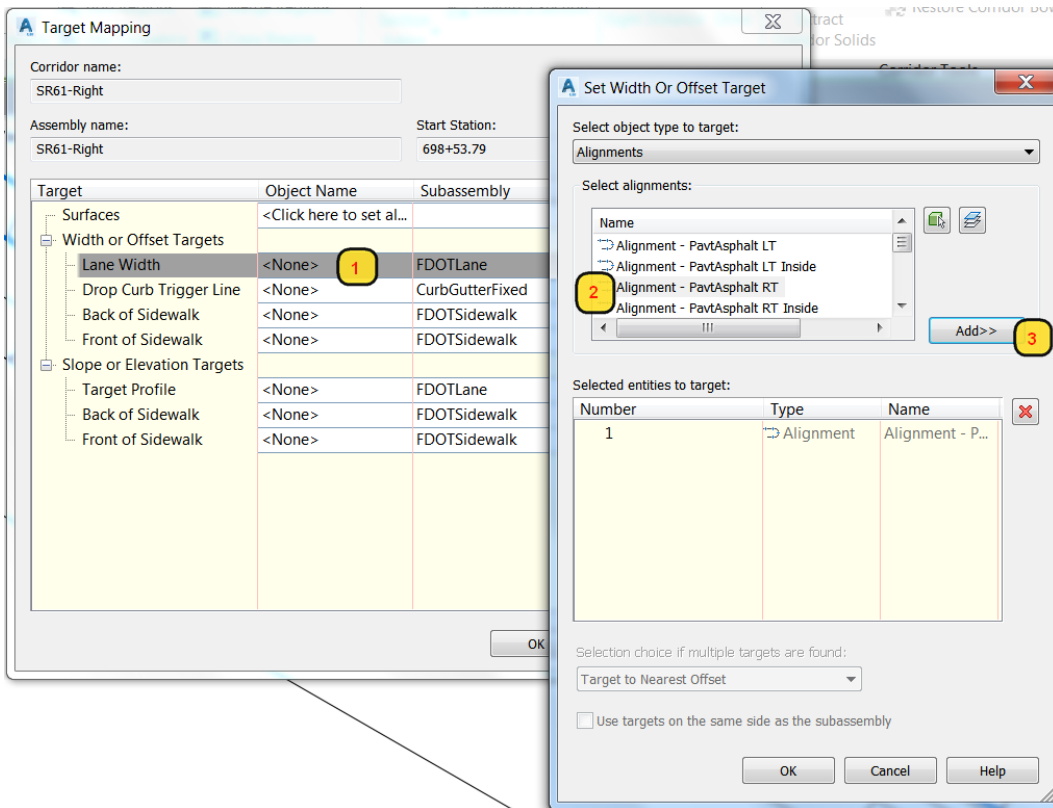

- The corridor is rebuilt. The Lane subassembly stretches to width of the Alignment – PavtAsphalt RT. The Curb and Sidewalk assemblies maintain their relative position to the outside of the Lane subassembly. Hover over each feature line to display the tooltip.

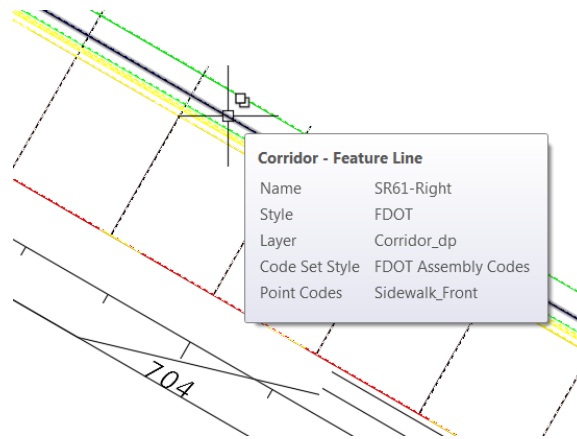

- Click the Save button.
- Restore the SE Isometric view. Zoom in to view the corridor model in 3D.

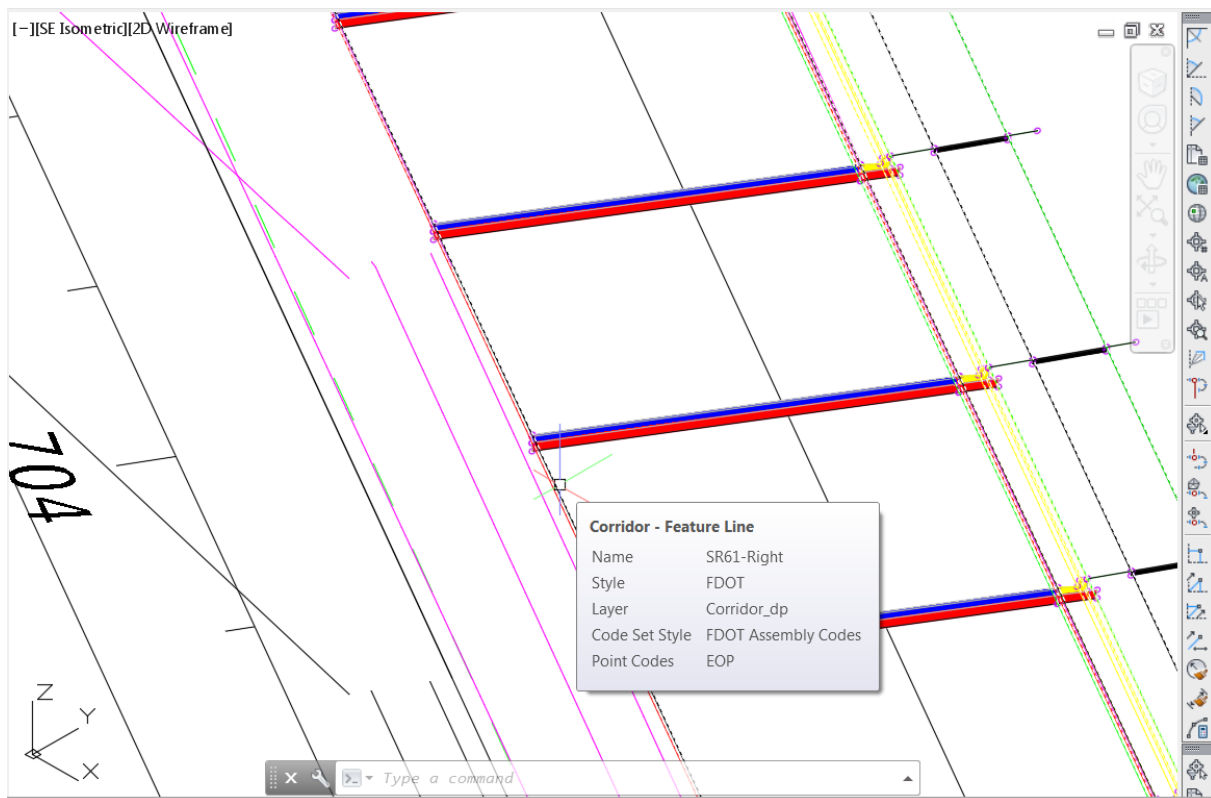

- The Lane subassembly now covers two through lanes and a bike lane. The Curb and Sidewalk subassemblies are more recognizable in the 3D view. Restore the Plan view and click the Save command.

Exercise 7.5 Creating a Corridor Model – Third Pass – Median and Left Turn Lane

Continue with the SR61-Right corridor model. Edit the Assembly to add a FDOT Lane subassembly to the left of the Assembly Marker. Add EOP Targets at Median and Left Turn Lanes.

1. Restore the Assemblies view. Click the Lanes – FDOT tab on the Tool Palette. Click the FDOT Lane subassembly. In the Properties Palette set the side to Left.
2. Set the slope to 2%. Set the width to 5'. The 5' width is arbitrary and for display purposes in the Assembly. The alignment targets will control the actual width of the Lane.
3. Point codes are used to name corridor feature lines. The Pavement Inside Edge Point Code represents the side closest to the assembly marker. If this were a simple crowned road the assembly marker would represent the crown at the CL making it the inside edge of the lane. In this example the inside edge of the lane represents the PGL at the inside edge of the through lane on the Right side of SR61. Enter R_PGL for the Pavement Inside Edge Point Code.

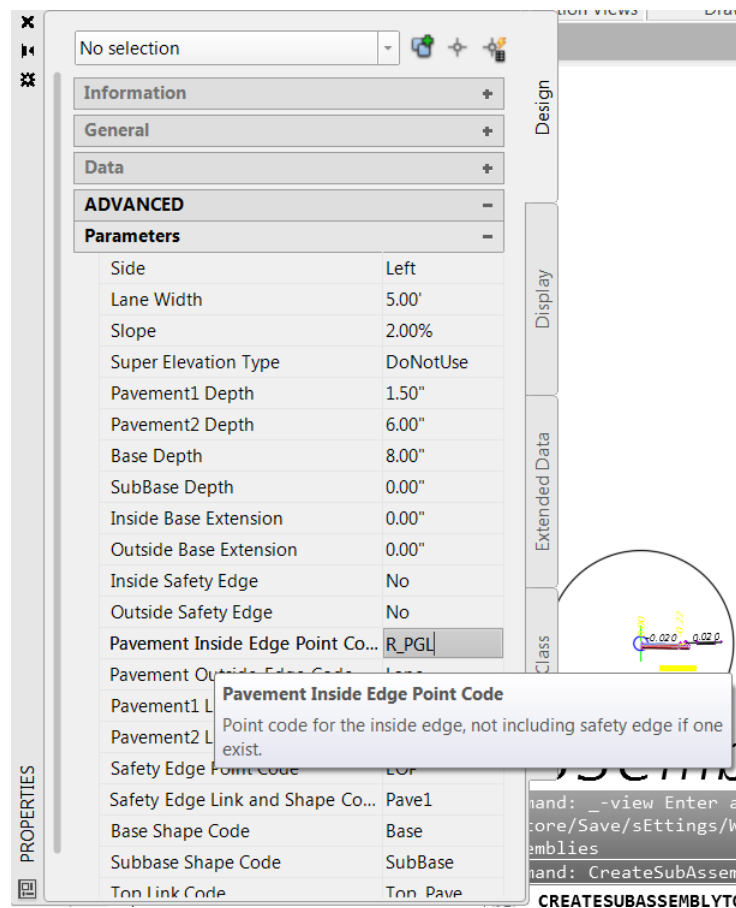

- In this example the Target Mapping uses alignments along the median and traffic separators. They collectively represent the R_Inside EOP at Median. Set the Pavement Outside Edge Code Point to R_Median. Pick the larger circle at SR61-Right Assembly Marker to place the subassembly. Press ESC to end the command.

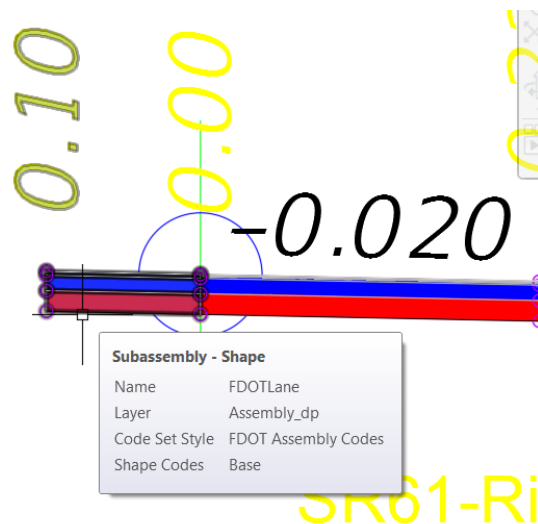
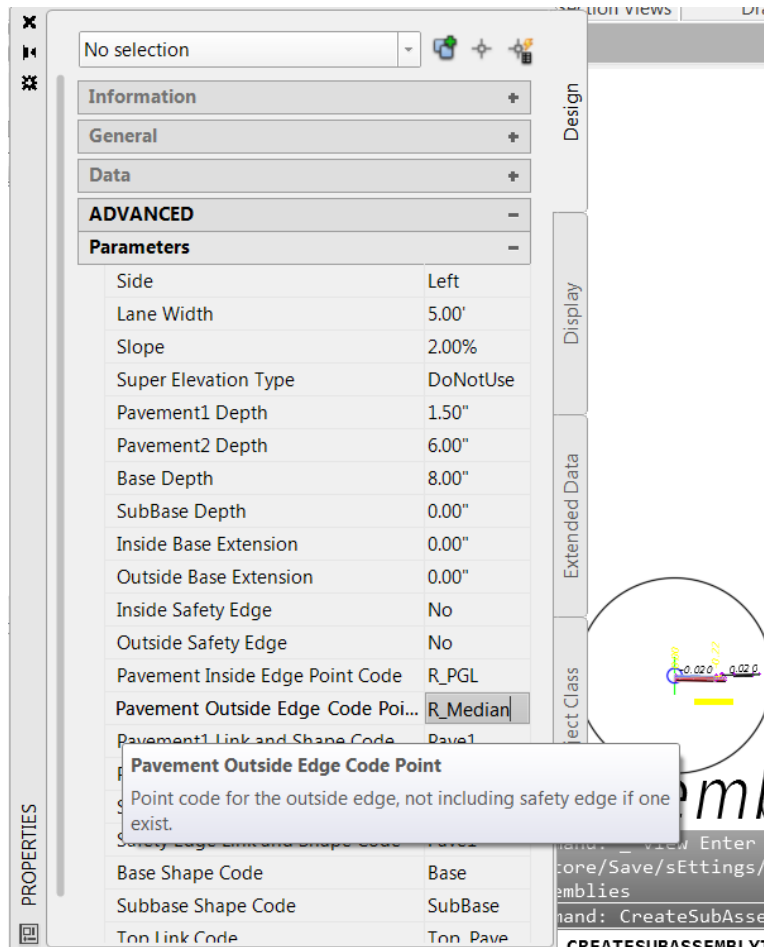

- Restore the Plan view. Grip the corridor model. Click the Edit Targets command. Click inside the blue highlighted area of the corridor model to select the Region in response to the command line prompt Select a region to edit:. In the Target Mapping dialog click the cell in the Object Name column on Lane Width row of the Left Assembly Group.

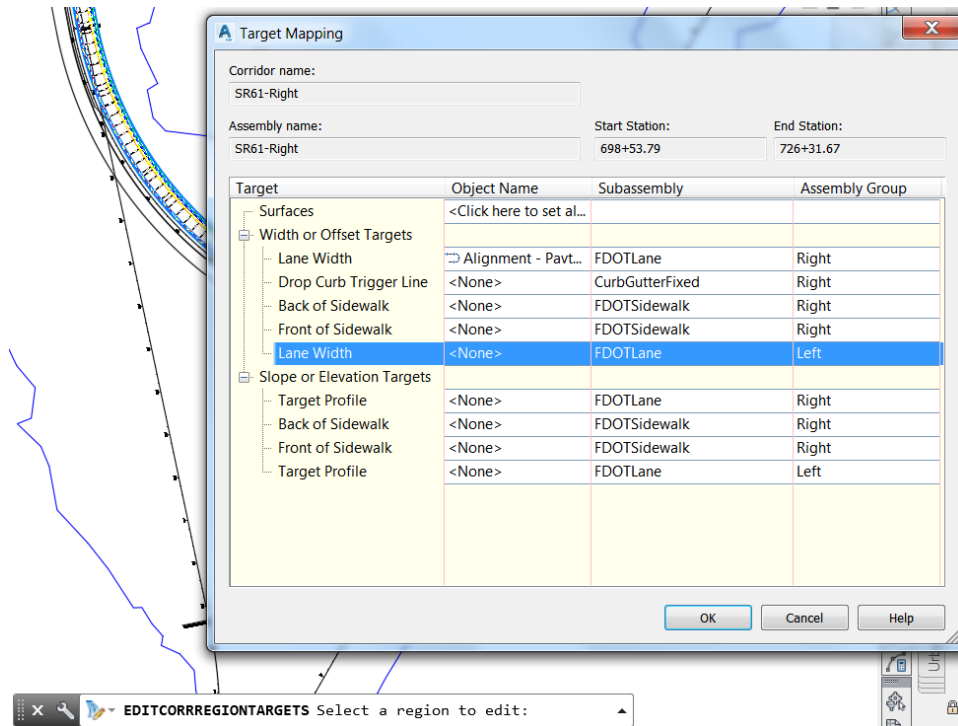

- In the Set Width Or Offset Target dialog click the Select from drawing button.

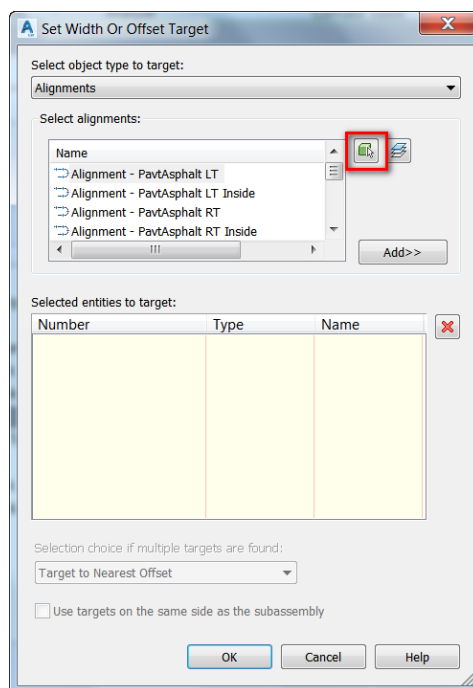

7. Zoom to an area near station 701 and pick the alignment on the right side of the traffic separator. Zoom to an area near station 711 and pick the alignment on the right side of the median. Zoom to an area near station 714 and pick the alignment on the right side of the traffic separator. Press Enter to return to the Set Width Or Offset Target dialog.

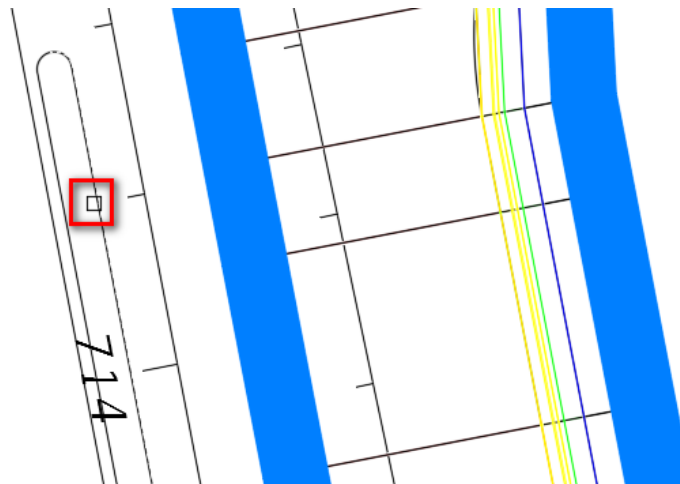
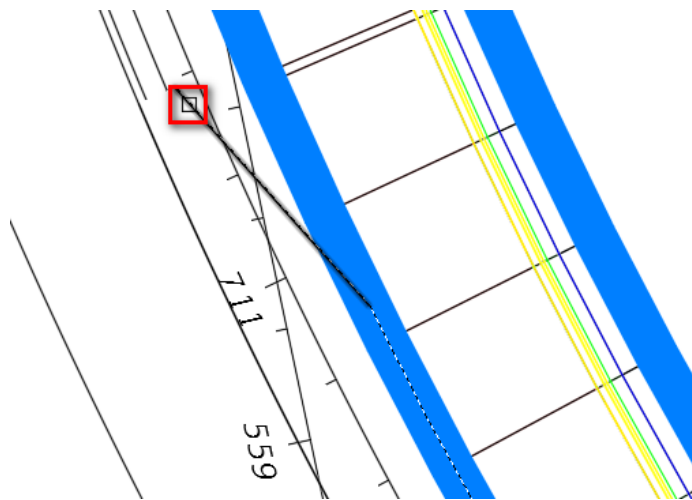
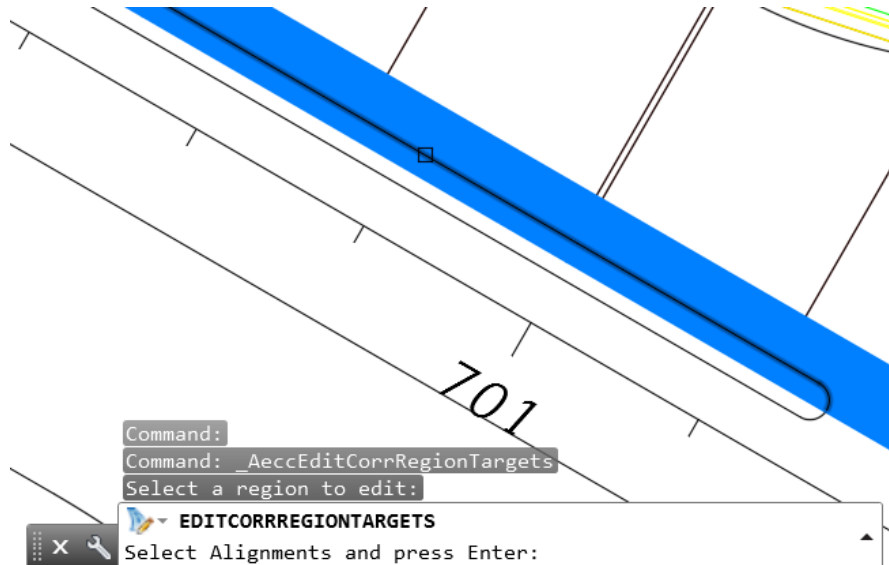

8. Click the Add button. The three alignments are added to the Selected entities to target: list. Resize the column widths to display the alignment names. Click OK. Click OK again to close the Target Mapping dialog. Press ESC to end the Edit Targets command.

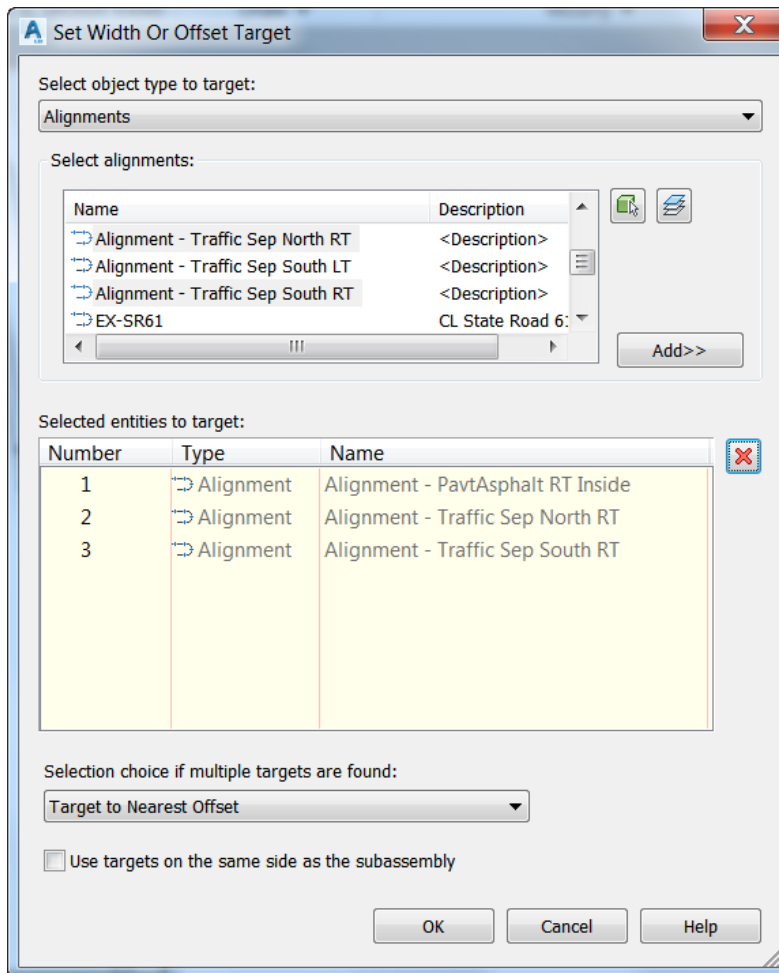

9. Zoom to station 711. Notice the median alignment tapers toward the traffic separator to form a Left Turn Lane. Click the Save button.

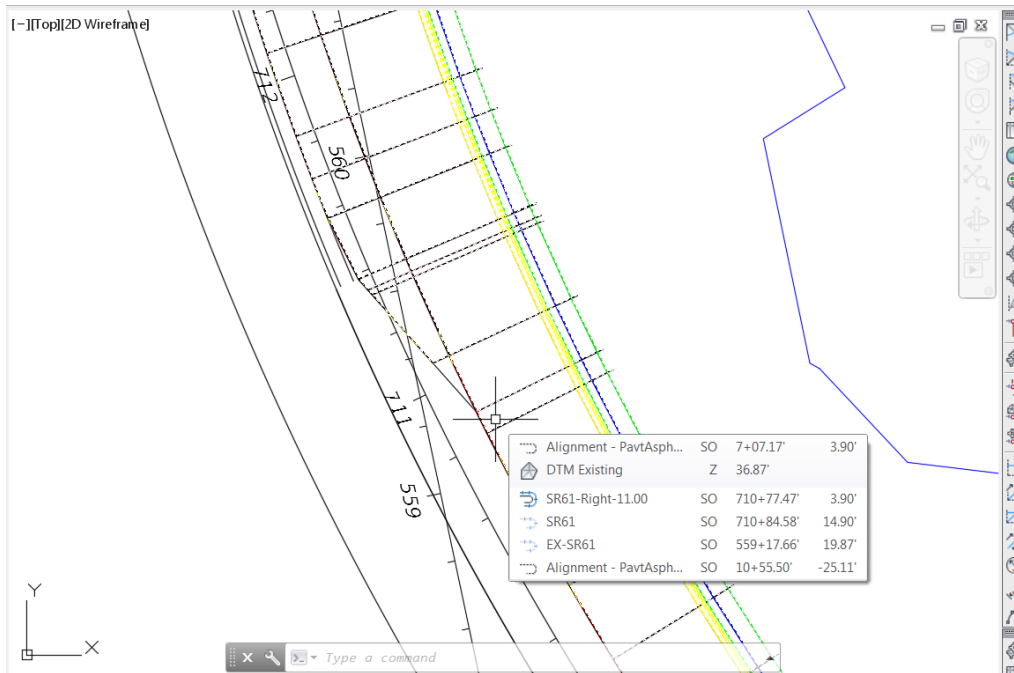

10. Restore the SE Isometric view. Zoom to Station 711. The Lane subassembly on the left widens to form the left turn lane at the traffic separator. Restore the Start view.

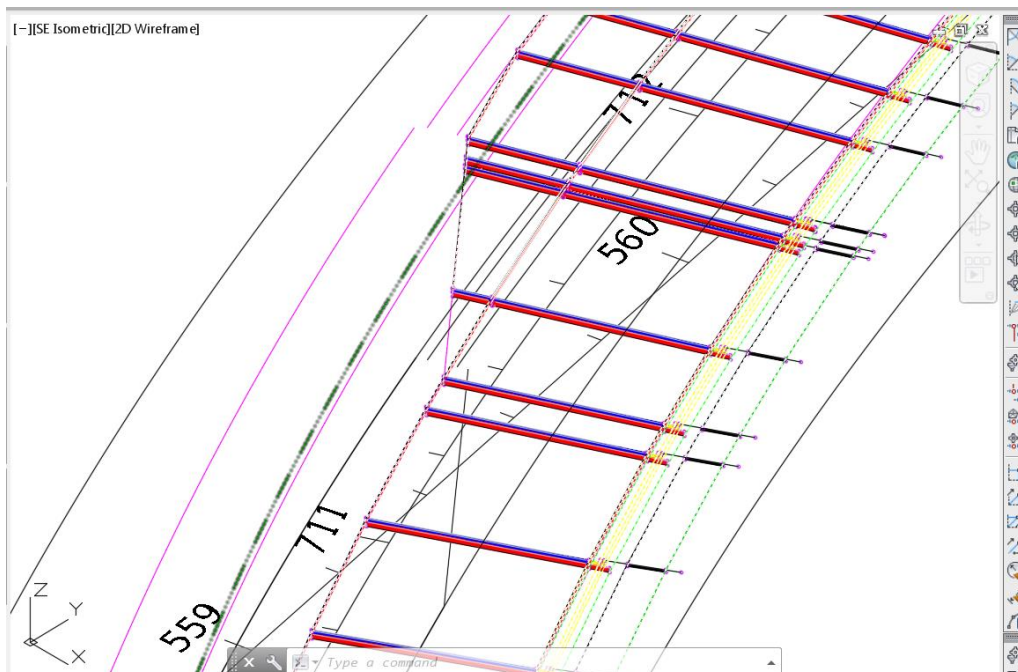

- Expand the Corridors collection in the Prospector. Corridor related commands are available by right clicking on the corridor name SR61-Right. Expand the Assemblies collection. Notice how the subassemblies are organized by their position Right or Left of the Baseline (a.k.a. assembly marker)

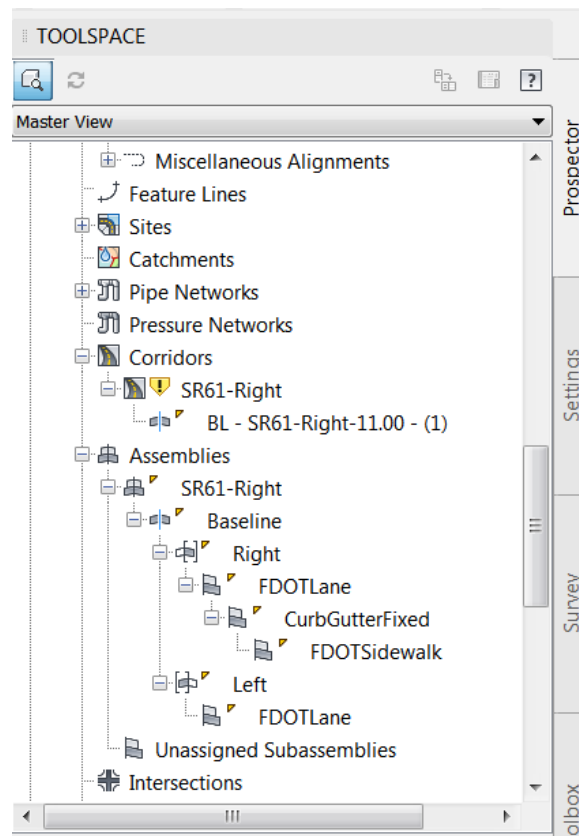

- Save and Close MODLRD02.dwg

8 Corridor Surface

DESCRIPTION

You will create a surface from a corridor model in this chapter. When you review the results, you will use the object viewer.

OBJECTIVES

In this Chapter you will:

- Create a corridor surface using the commands in the corridor properties dialog.
- Apply a surface boundary using the commands in the corridor properties dialog.
- Review the surface in the Prospector.
- Change the Surface Style in the Surface Properties dialog
- Display the surface as triangles.
- View the surface in the Object Viewer.
- Change the Visual Style in the Object Viewer
- Change the View Controls in the Object Viewer
- Create 3D solids from the corridor model.

CHAPTER SETUP

Run the Chapter 8 - 22049555201.exe file and restore all files to the C:\Civil 3D 2017 Projects folder.

Do not change the location in which the Practice Files are installed. Doing so can cause errors when completing the exercises in this training manual.

Exercise 8.1 Create MODLRD03.dwg

In this exercise you will create the MODLRD03 file to be used to create a Corridor Surface.

1. From the **Select File** dialog box, navigate to the *C:\Civil 3D 2017 Projects\22049555201\Roadway* folder and select **8.1 - Creating a Corridor Surface.dwg**. Click **Open**.
2. Right click the drawing tab and click **Save As**. From the **Save Drawing As** dialog box, navigate to the *C:\Civil 3D 2017 Projects\22049555201\Roadway* folder and type **MODLRD03.dwg** for the File name. Click **Save**.
3. Associate MODLRD03.dwg File to the Project. From the *TOOLSPACE > Prospector tab > Data Shortcuts* [C:\Civil 3D 2017 Projects\22049555201], right-click and select **Associate Project to Current Drawing**.

Exercise 8.2 Corridor Model Properties

In this exercise you will create a corridor surface using commands and settings available in the Corridor Properties dialog box.

1. To create a corridor surface open the Corridor Properties dialog. On the *Toolspace > Prospector* tab expand the Corridors collection and right click SR61-Right. Click **Properties**.

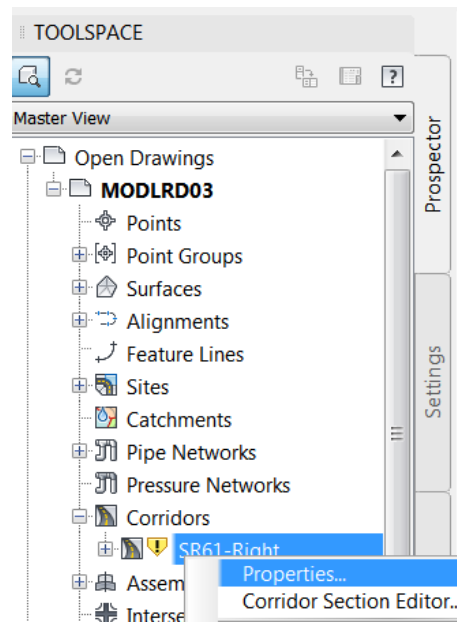

- Click the Surfaces tab. Click the Create a corridor surface button on the far left. Edit the surface name to SR61-Right. Set the Surface Style to Contours Major 5' Minor 1'. With the Data type set to Links and the Specify code: set to Top click the + Add surface item button.

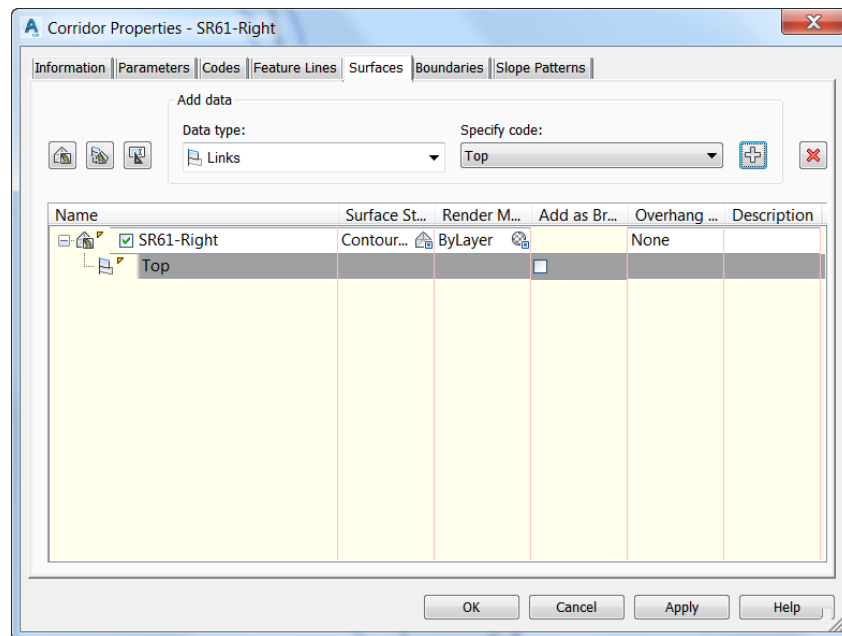
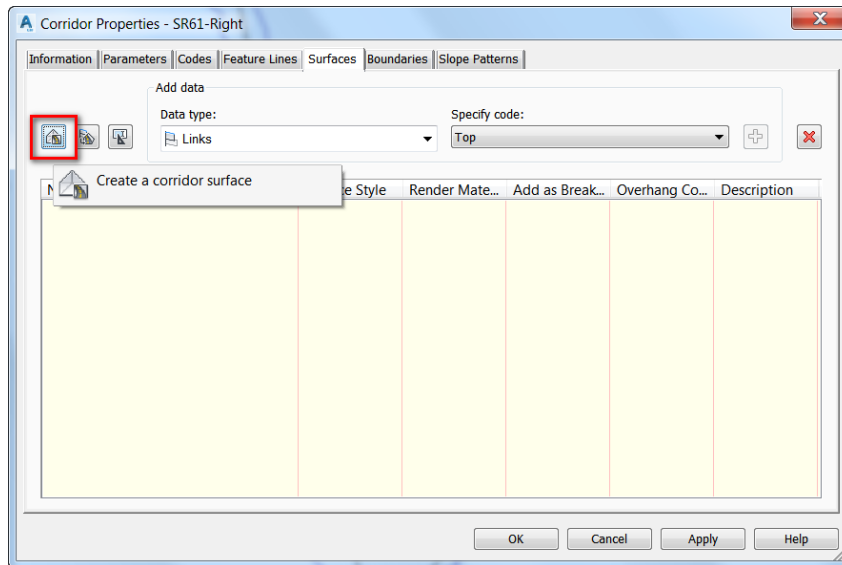

- Click the Boundaries tab. Right click the SR61-Right and click Corridor extents as outer boundary. Click OK. Click Rebuild the corridor.

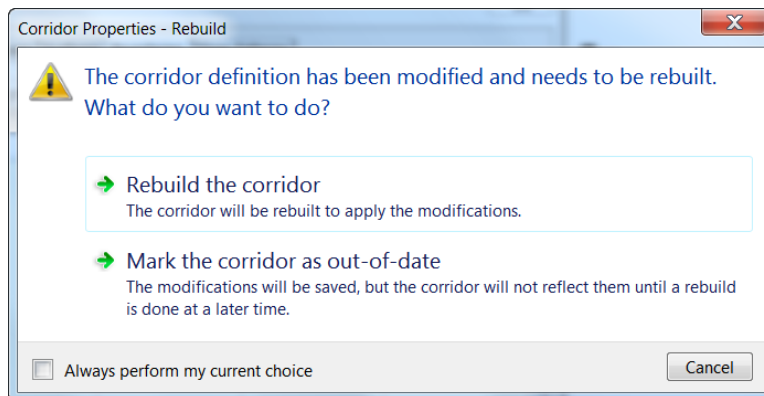
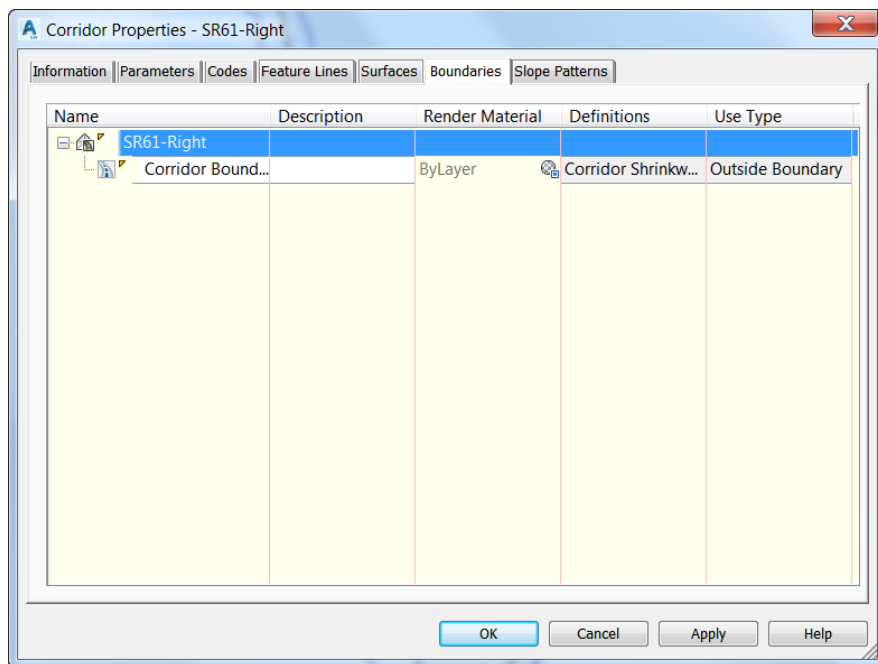
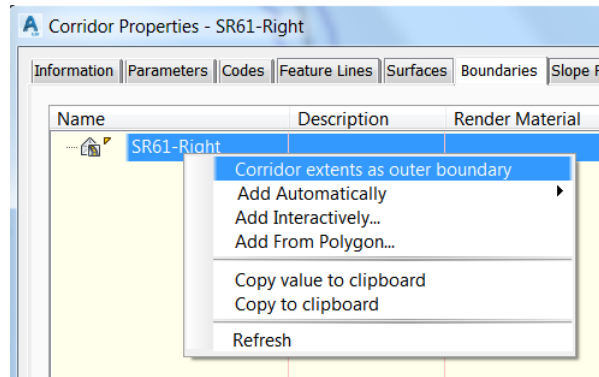

- Review in Toolspace. Expand the Surfaces collection in the Prospector. Right click the surface SR61-Right. Click Surface Properties. On the Information tab notice the Surface Style is set to Contours Major 5' Minor 1'. Click the Definition tab. Notice the Operation type has one item: Surface From Corridor.

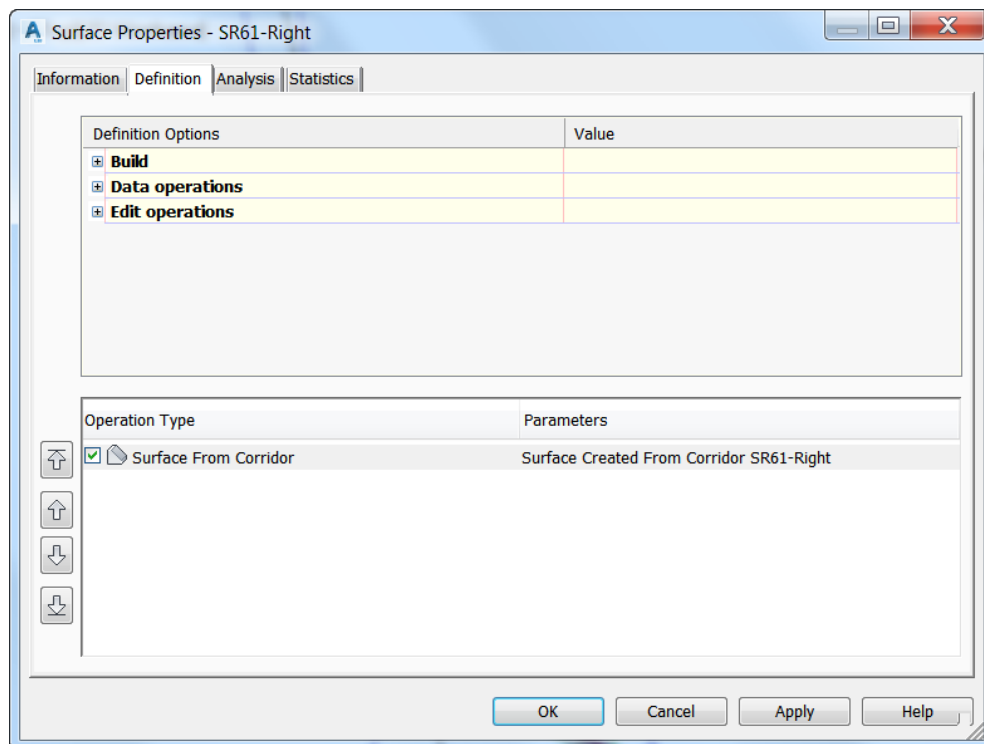
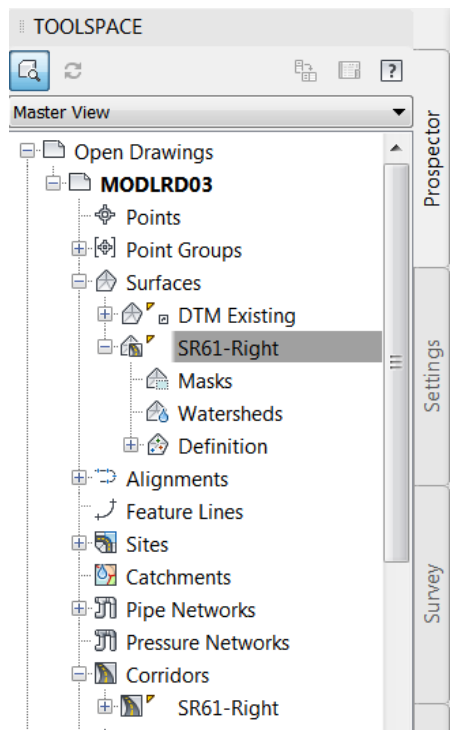

5. Review the SR61-Right surface as it is displayed in the drawing. Zoom to station 708. Hover over a contour. The tooltip identifies the object as a Corridor Surface.



Exercise 8.3 3D Display Techniques

In this exercise you will see different ways to view the corridor surface in 3D. The first uses the Object Viewer to allow you to rotate the surface and apply display styles without affecting the display in the drawing editor. The second uses 3D solids generated from the corridor model. The third shows a slice through the corridor solids.

1. Using the Object Viewer. Grip the surface by picking one of the contours. Click Surface Properties from the ribbon. On the Information tab set the surface style to Triangles Exag 3-1 Proposed. Click Apply. Click OK.

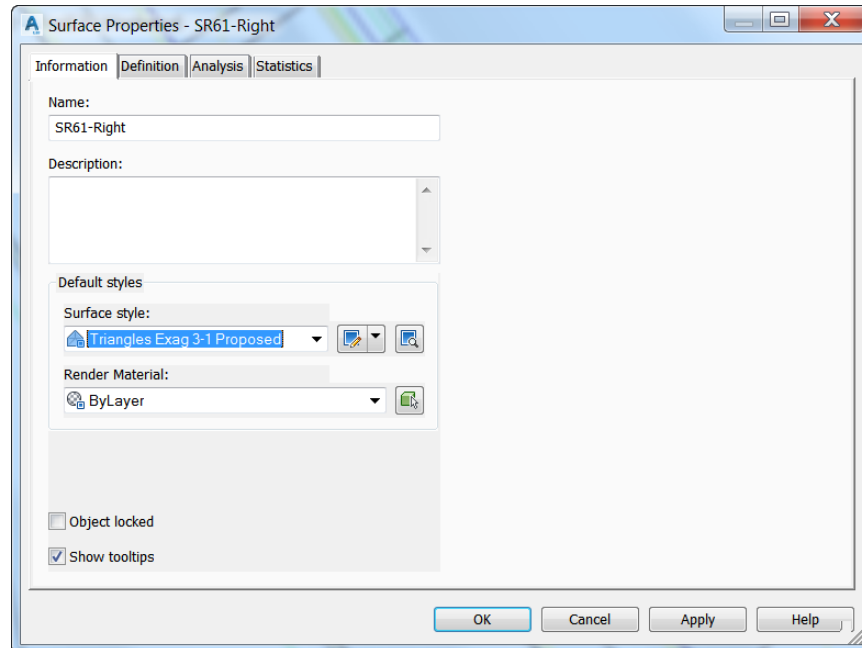

2. Click the Object Viewer command on the ribbon. Set the Visual Syles drop down list in the upper left corner to Shaded with edges. Set the View Control to SE Isometric. Use the Zoom Window button to zoom closer to the turn lane.

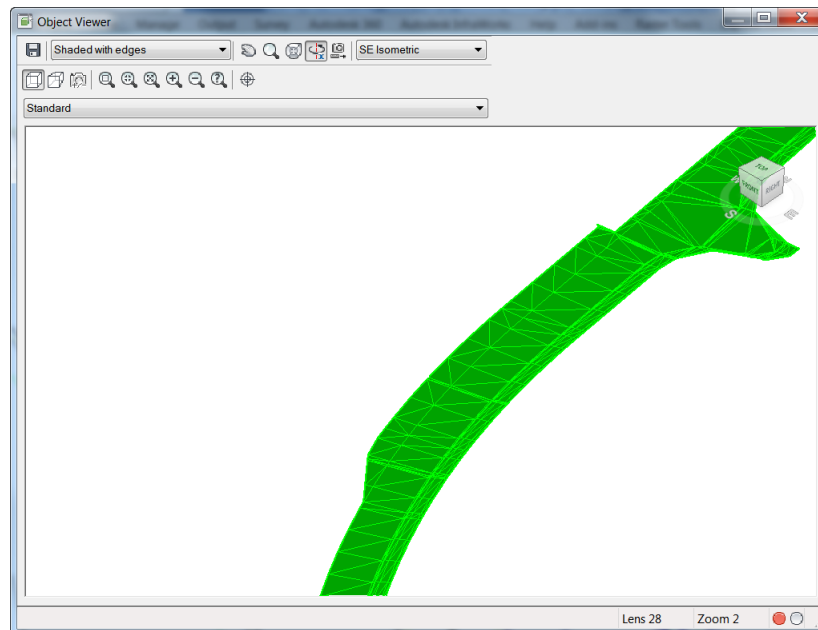
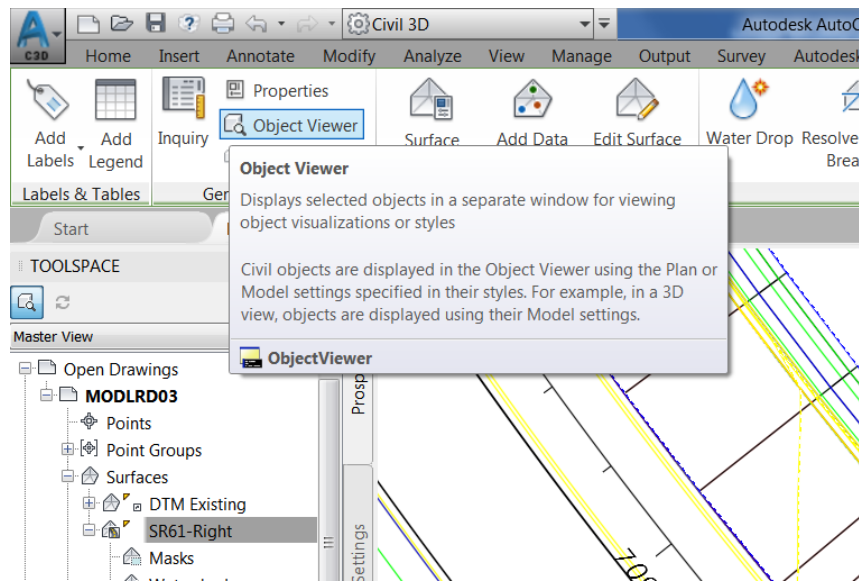

- Set the View Control to NW Isometric. Use the Zoom Window button to zoom closer to the turn lane. Notice the curb face is much more prominent when the surface style has a 3x vertical exaggeration applied. Close the Object Viewer by clicking the X in the upper right corner.

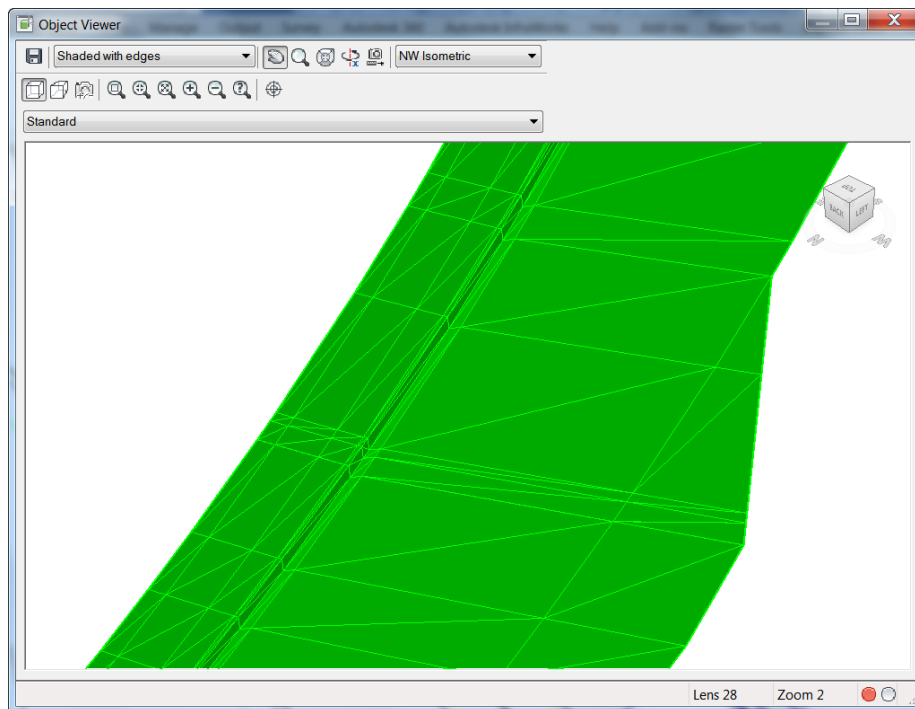

- Exporting Corridor Solids. Grip the surface by picking the edge of one of the blue triangles. Use the Surface Properties dialog to set the Surface Style to No Display. Grip the corridor model. Click the Extract Corridor Solids from the Corridor Tools panel in the ribbon. Click the All Regions hyperlink on the command line. Use the default settings on all three panels in the Extract Corridor Solids dialog. Click Extract Solids.

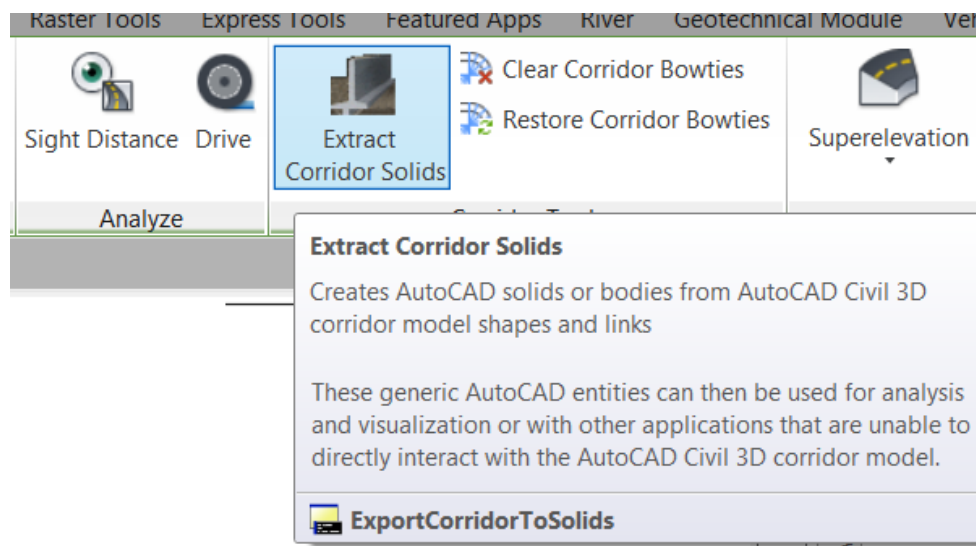

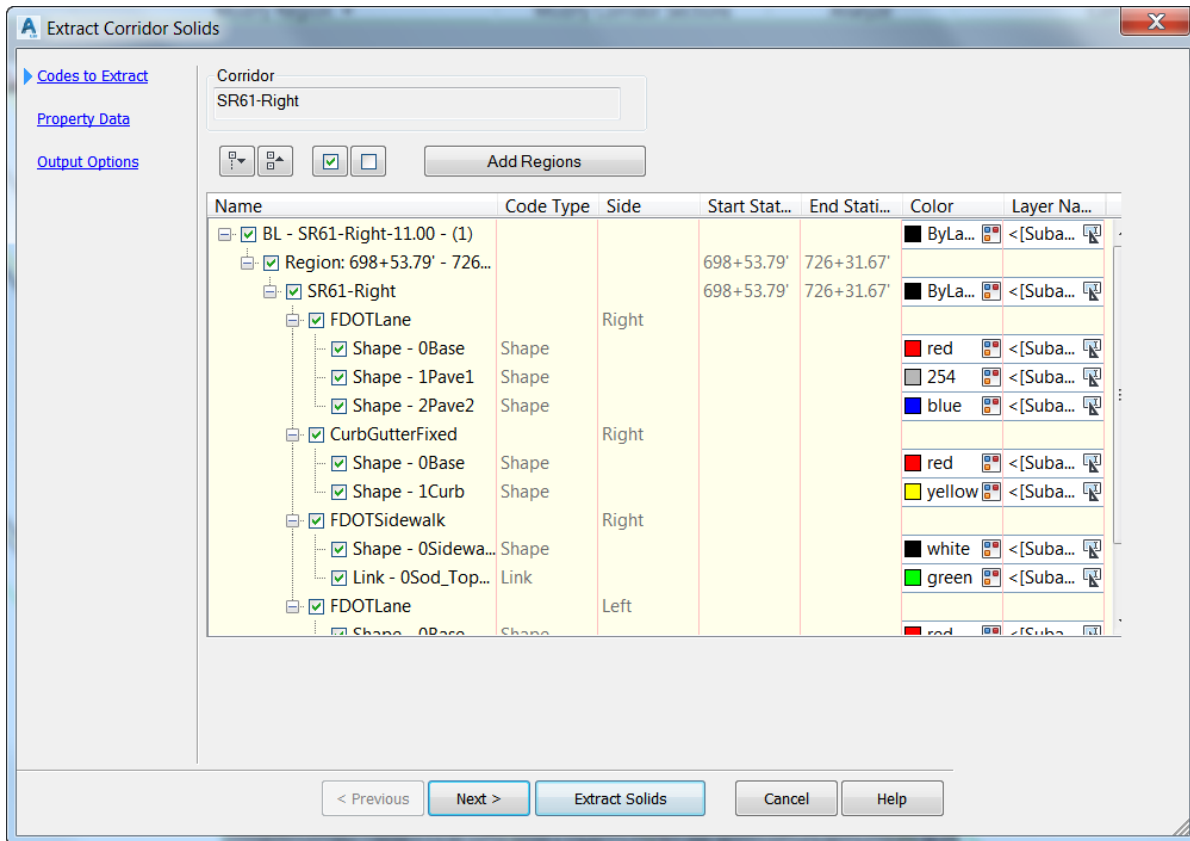

5. Save the MODLRD03 drawing.
6. Set the View Controls to NW Isometric. Set the Visual Style Controls to Realistic. Zoom to the turn lane near station 712. Hover the cursor over the model to display the tooltip 3D Solid.

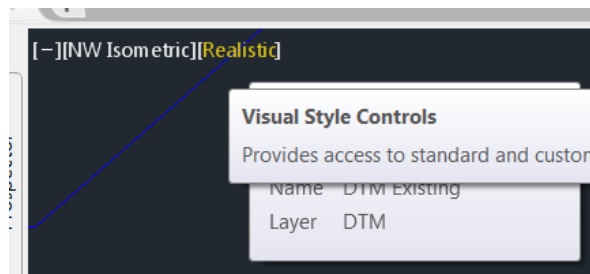

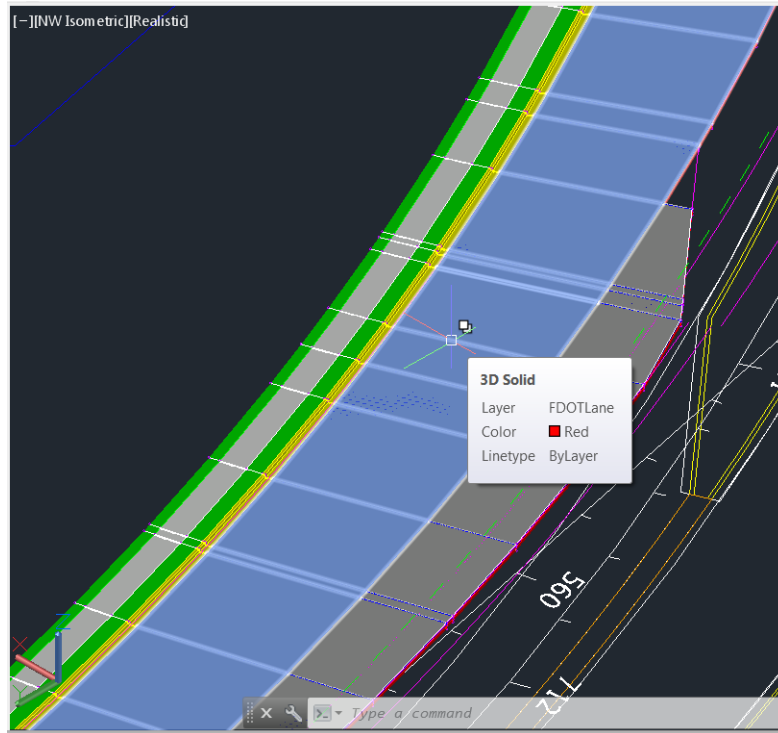

7. Viewing a section cut through corridor model solids. Set the View Controls to Plan. Zoom to station 712. Set the Workspace to 3D Modeling.

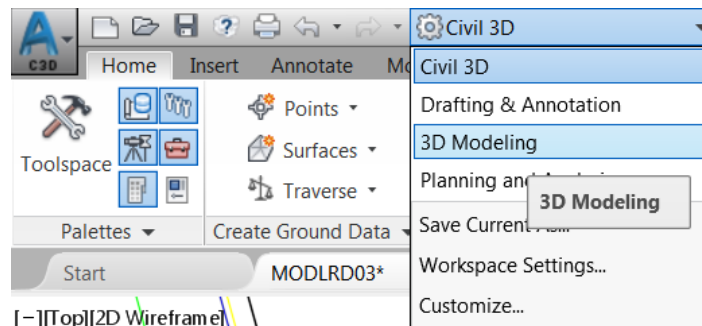

8. Click the Section Plane command from the Home tab > Section panel on the ribbon. Click the Draw section hyperlink on the command line. Turn off running object snaps.

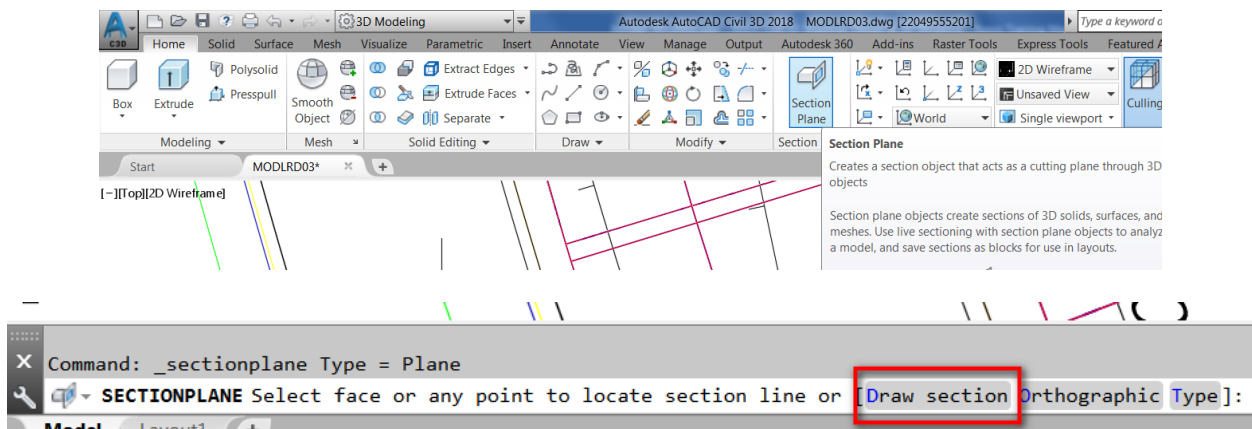

- Pick the start point near the station label 712. Pick the next point just beyond the sidewalk at station 712. Press Enter. Pick a location north of the section line to respond to the command line prompt, Specify point in direction of section view:. Hover over the section object to display the tooltip.

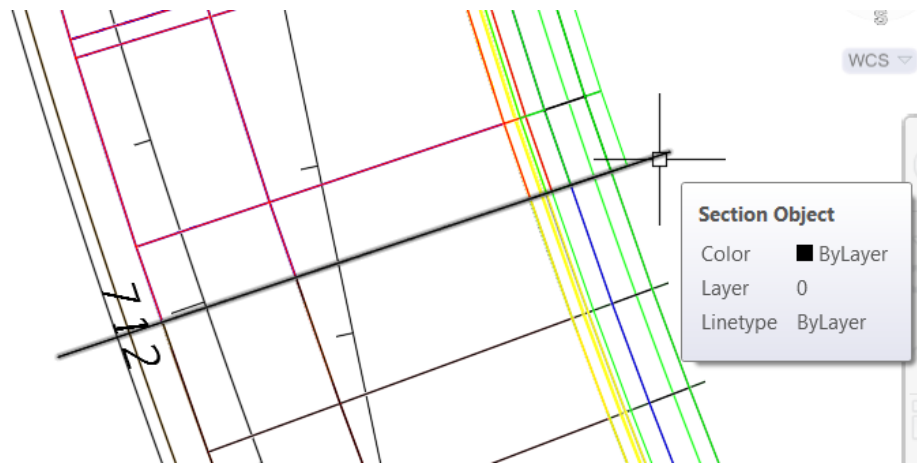

- Set the View Controls to SE Isometric. Zoom in to station 712. Set the Visual Style Controls to Conceptual. The corridor solids are cut away at the section object revealing the depth and underlying material specified in the subassemblies.

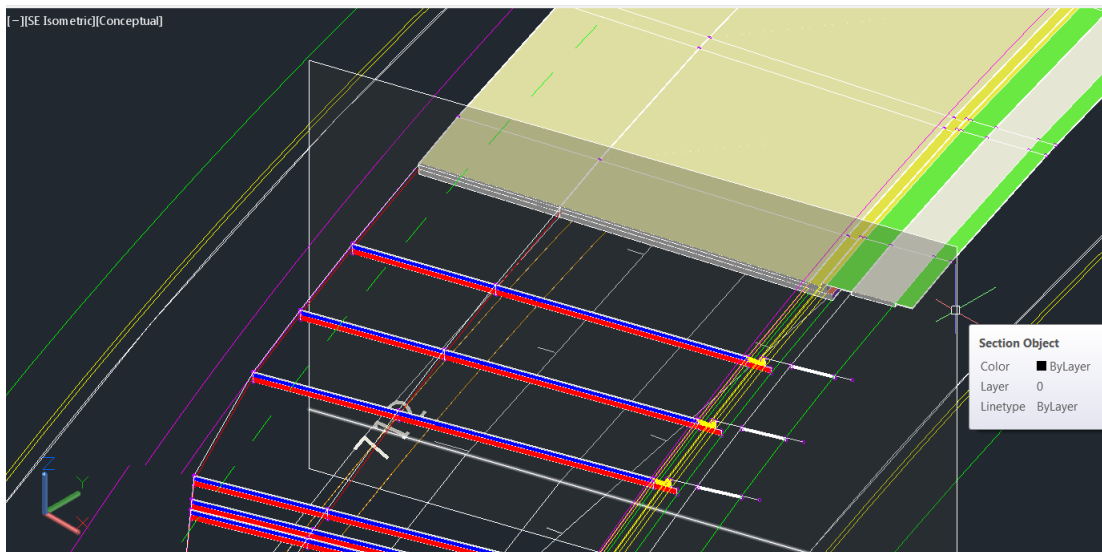

- 11. You may wish to create a live section to display a slice through the solids. The steps for creating a live section are not included in this manual. Set the Civil 3D Workspace current. Set the View Controls to Plan. Save.

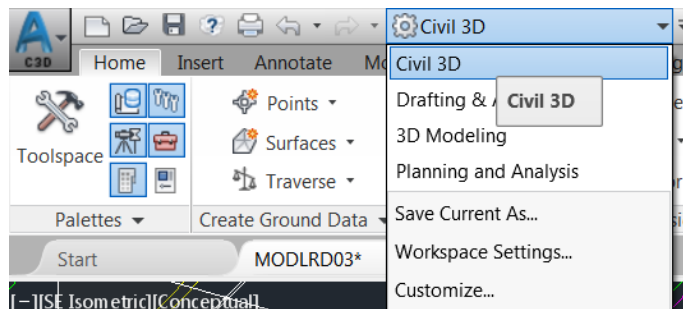
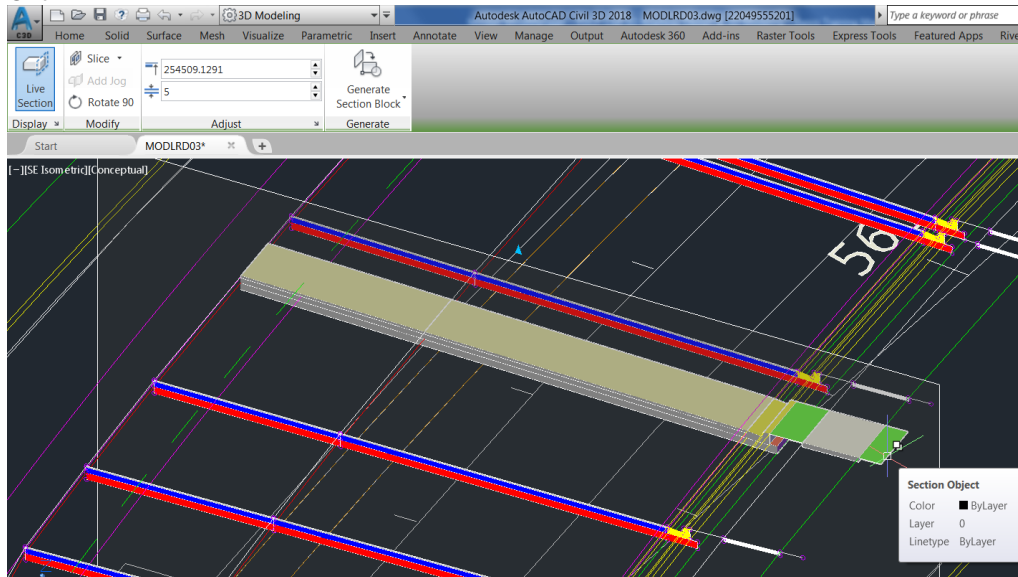

9 Create SR61-Left Corridor

DESCRIPTION

In this chapter you will apply your skills learned in the previous chapter to create a corridor model on the left side of SR61.

OBJECTIVES

In this Chapter you will:

- Copy an Assembly
- Mirror subassemblies
- Add a daylight subassembly
- Create a corridor model
- Assign targets to the corridor model

CHAPTER SETUP

Run the Chapter 9 - 22049555201.exe file and restore all files to the C:\Civil 3D 2017 Projects folder.

Do not change the location in which the Practice Files are installed. Doing so can cause errors when completing the exercises in this training manual.

Exercise 9.1 Create MODLRD02.dwg

In this exercise you will create the MODLRD02 file to be used to create a Corridor Surface.

1. From the **Select File** dialog box, navigate to the *C:\Civil 3D 2017 Projects\22049555201\Roadway* folder and select **9.1 - Creating SR61-Left Corridor Model.dwg**. Click **Open**.
2. Right click the drawing tab and click **Save As**. From the **Save Drawing As** dialog box, navigate to the *C:\Civil 3D 2017 Projects\22049555201\Roadway* folder and type **MODLRD02.dwg** for the File name. Click **Save**.
3. Associate MODLRD02.dwg File to the Project. From the *TOOLSPACE > Prospector tab > Data Shortcuts* [C:\Civil 3D 2017 Projects\22049555201], right-click and select **Associate Project to Current Drawing**.

Exercise 9.2 Create SR61-Left Assembly

In this exercise you will reuse the assembly for the right side of SR61 and configure it for use on the left side of SR61

1. Copy SR61-Right Assembly and rename to SR61-Left. Restore the Assemblies view. Click the Copy command from the Home tab > Modify panel. Pick the SR61-Right assembly marker. Pick the bottom quadrant of the circle as the base point. Pick the top quadrant of the circle as the destination. Press Enter to end the copy command.

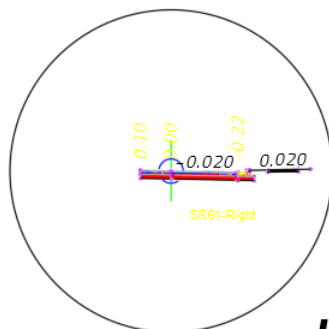
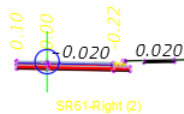

Assemblies

2. Rename the copied assembly to SR61-Left. Grip the assembly marker and click Assembly Properties in the ribbon. Type SR61-Left in the Name field and click OK.

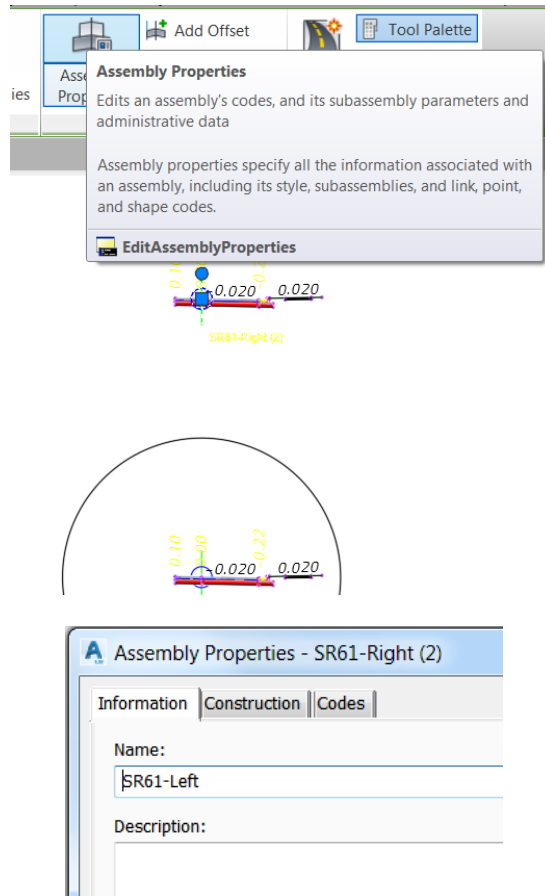

3. Mirror SR61-Left Assembly. Zoom in closer to the SR61-Left assembly. Use a crossing window to select all the subassemblies on the right side of the assembly marker. Click Mirror on the Modify Subassembly panel on the ribbon. Pick the assembly marker in response to the command line prompt Select marker point within assembly for the mirrored subassemblies. Press Delete on the keyboard to erase the highlighted subassemblies on the right side of the assembly marker. Use the same technique to Mirror the shorter FDOT Lane subassembly to the right side of the assembly marker.

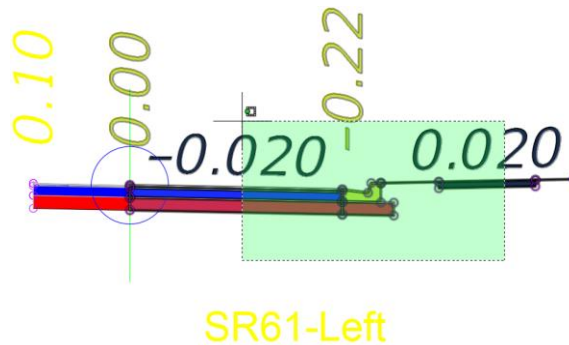

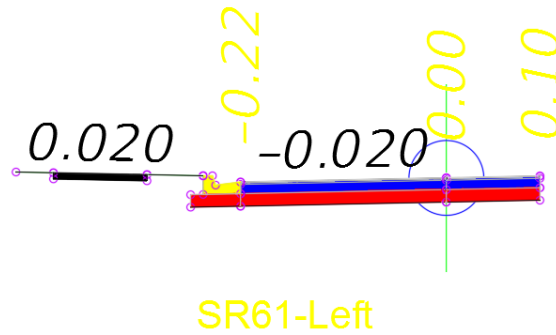
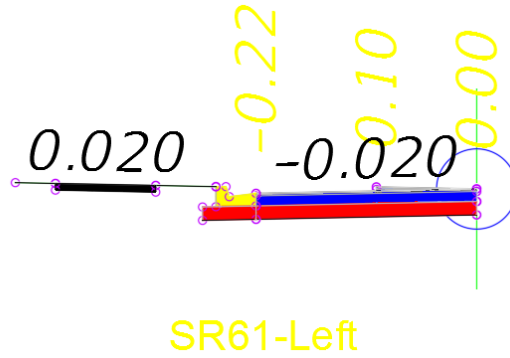

4. Edit the Point Codes changing the R_ prefix to L_. Grip the Lane subassembly on the right side of the assembly marker. Open the Properties Palette. Rename the two point codes.
 - Pavement Inside Edge Point Code is L_PGL
 - Pavement Outside Edge Code Point is L_Median

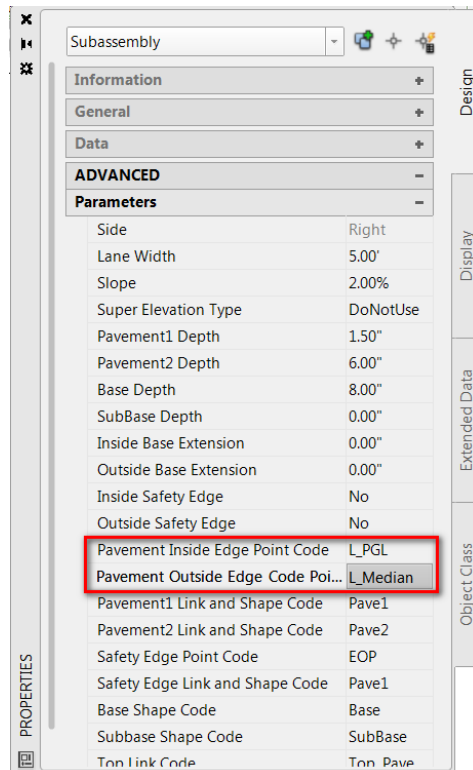

5. Add Daylighting Subassembly. Click the Daylight – FDOT tab on the Tool Palette. Click FDOT Simple Daylight. Pick the outermost circle on the Sidewalk subassembly. Press ESC. Click Save.

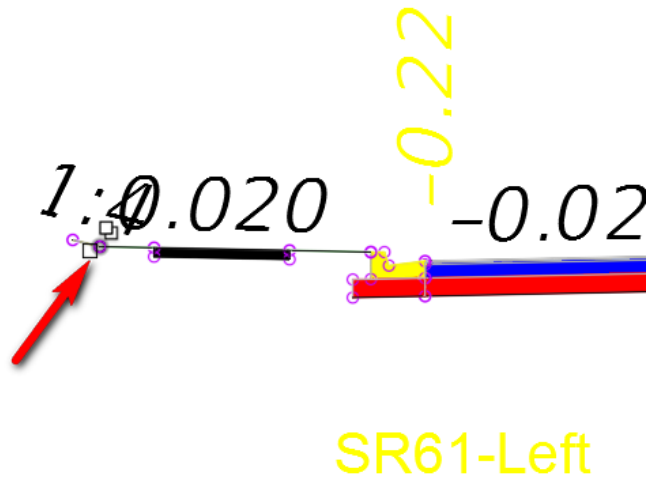
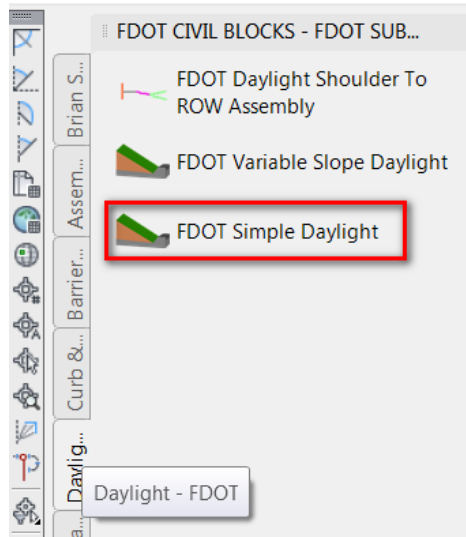

Exercise 9.3 Create Corridor Model SR61-Left

In this exercise you will create the SR61-Left corridor model which represents the left side of SR61.

1. Click the Corridor command under the Home tab > Create Design panel > Corridor button. Type SR61-Left in the Name field. Select SR61-Left-11.00 from the Alignment drop-down list. Select SR61-Left-PGL from the Profile drop-down list. Select SR61-Left from the Assembly list. Select DTM-Existing for the Target Surface. Click OK.

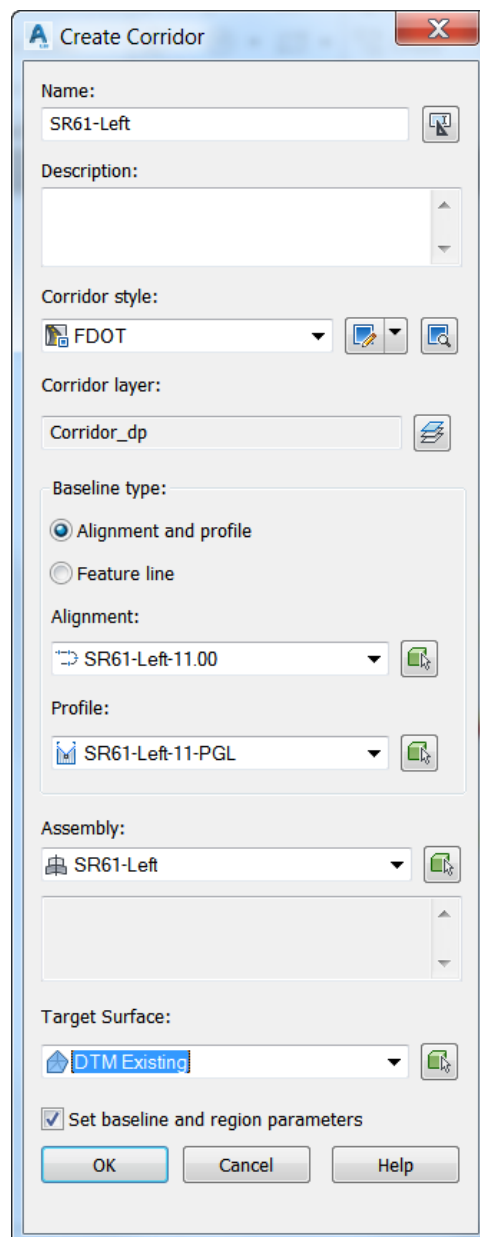

- Assign Targets. The Baseline and Region Parameters dialog opens after the Create Corridor dialog closes. Click Set all Targets.

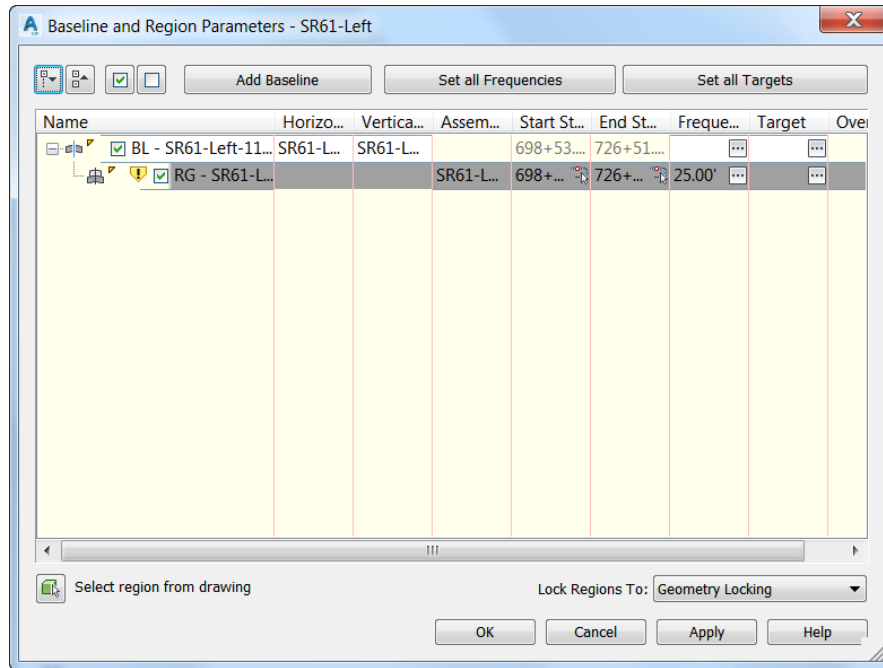

- In the Target Mapping dialog click the cell in the Object Name column on Lane Width row in the Assembly Group Left (2). In the Set Width Or Offset Target dialog select Alignment - PavtAsphalt LT then click the Add button. This alignment represents the outside edge of pavement. Click OK.

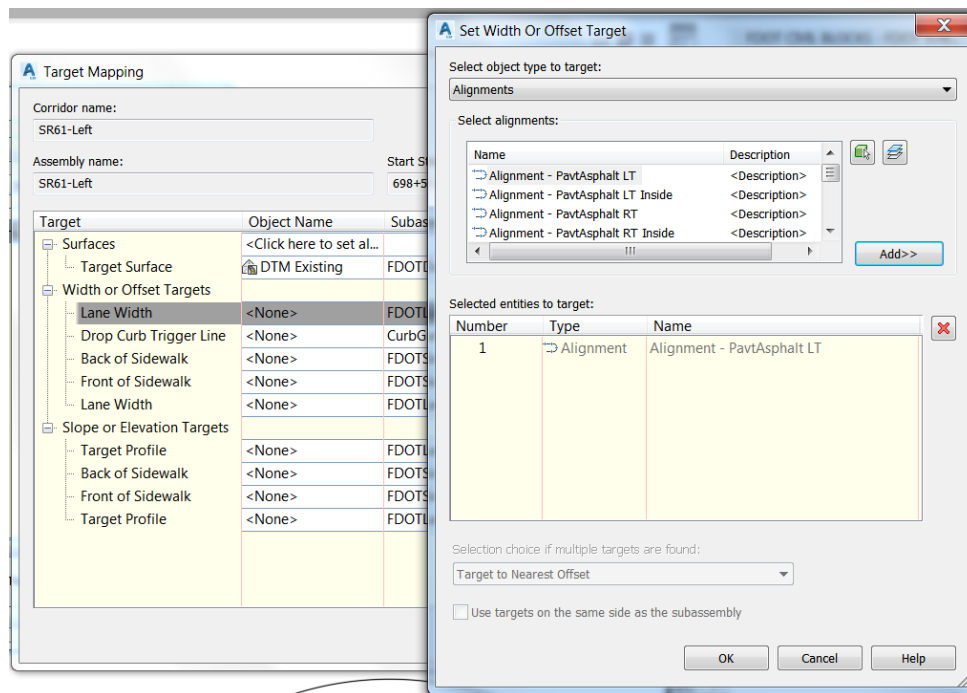

- In the Target Mapping dialog click the cell in the Object Name column on Lane Width row in the Assembly Group Right. In the Set Width Or Offset Target dialog hold down the Ctrl key while selecting Alignment - PavtAsphalt LT Inside, Alignment - Traffic Sep North LT, and Alignment Traffic Sep South LT. Click the Add button. These alignments represent the inside edges of pavement. Click OK

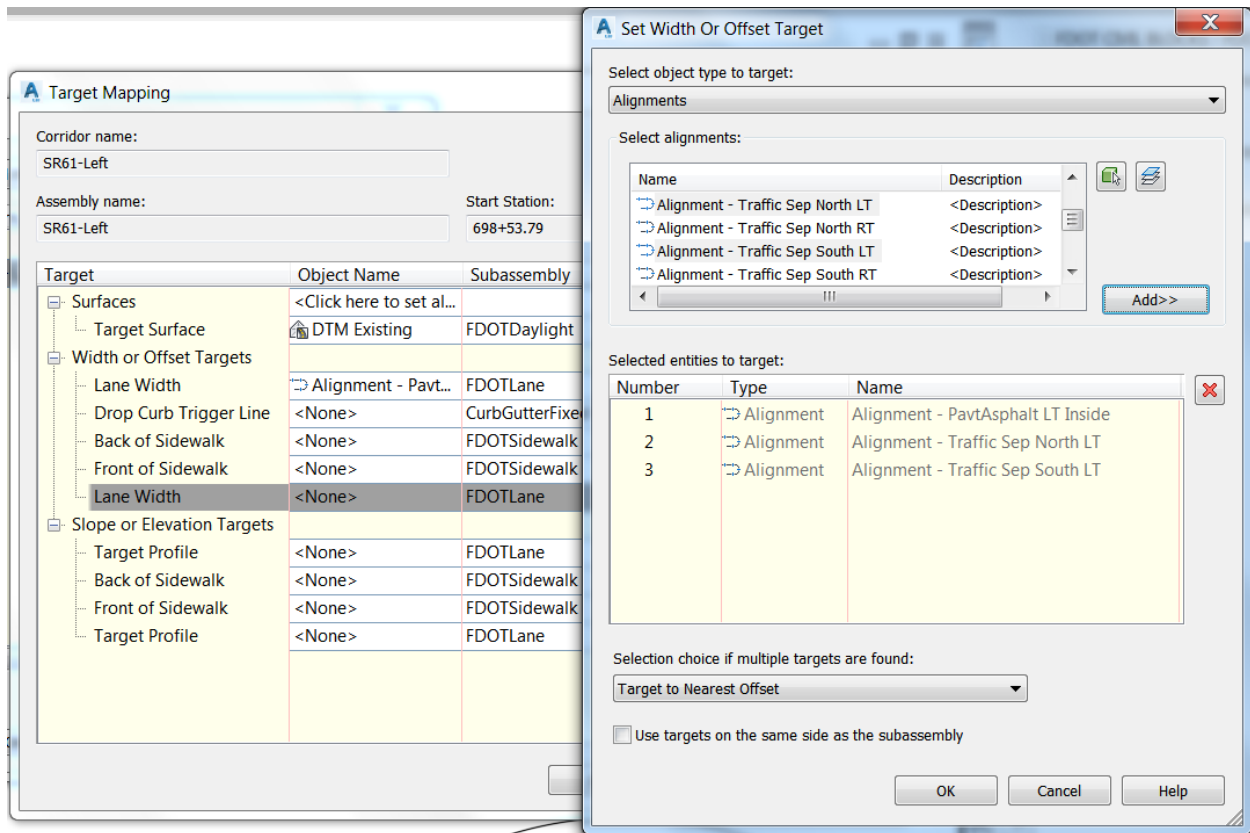

- Click OK again to close the Target Mapping dialog. Click OK to dismiss the Baseline and Region Parameters dialog. Click Rebuild the Corridor. The Event viewer in the Panorama Palette shows errors at the beginning and ending alignment stations where there is no surface data to target for daylighting. This problem will be addressed in the next Chapter. Close the Panorama Palette. Click Save.

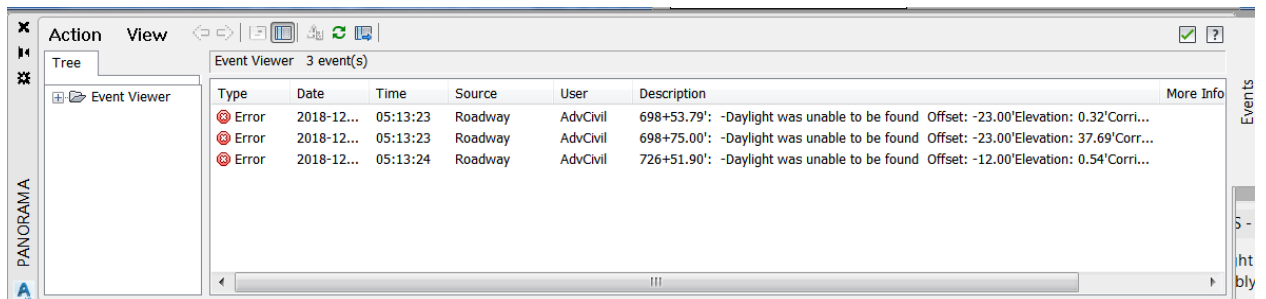

- Review the corridor models. Restore the Plan view in View Controls in the upper left of the canvas. The left and right sides of SR61 are corridor models. The left side shows the daylighting outside of the sidewalk.



- Add the daylight subassembly to the SR61-Right assembly. Restore the Assemblies view in View Controls. Click the Daylight – FDOT tab on the Tool Palette. Click FDOT Simple Daylight. Pick the outermost circle on the Sidewalk subassembly on the SR61-Right Assembly. Press ESC. Click Save.

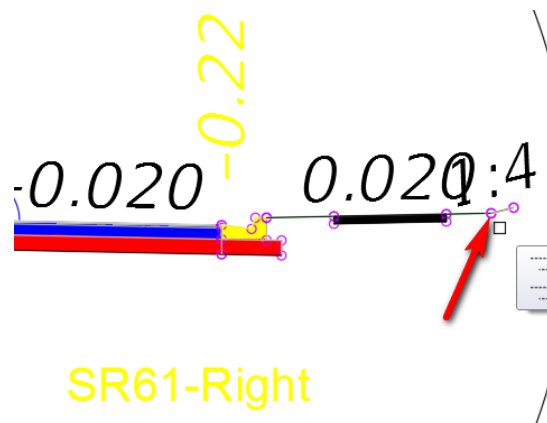

8. Assign the daylight target to the SR61-Right corridor model. Restore the Plan view in View Controls. Zoom in to station 712. Grip the SR61-Right corridor model. Click the Edit Targets command in the ribbon. Click inside the SR61-Right corridor model area to select the region. Set the Target Surface to DTM Existing. Click OK. Press ESC to end the Edit Targets command. The corridor is rebuilt and the daylight lines appear outside the Sidewalk on the SR61-Right corridor model.

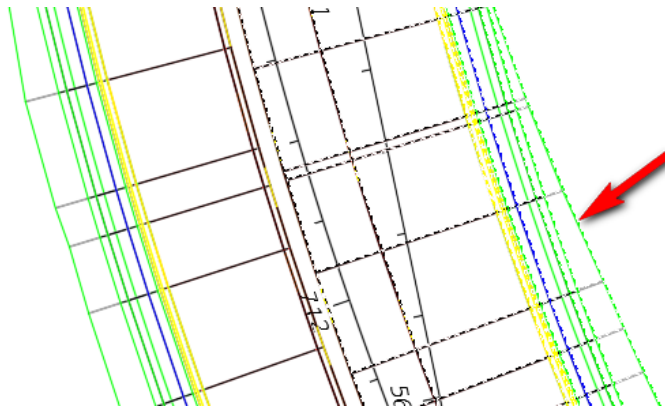
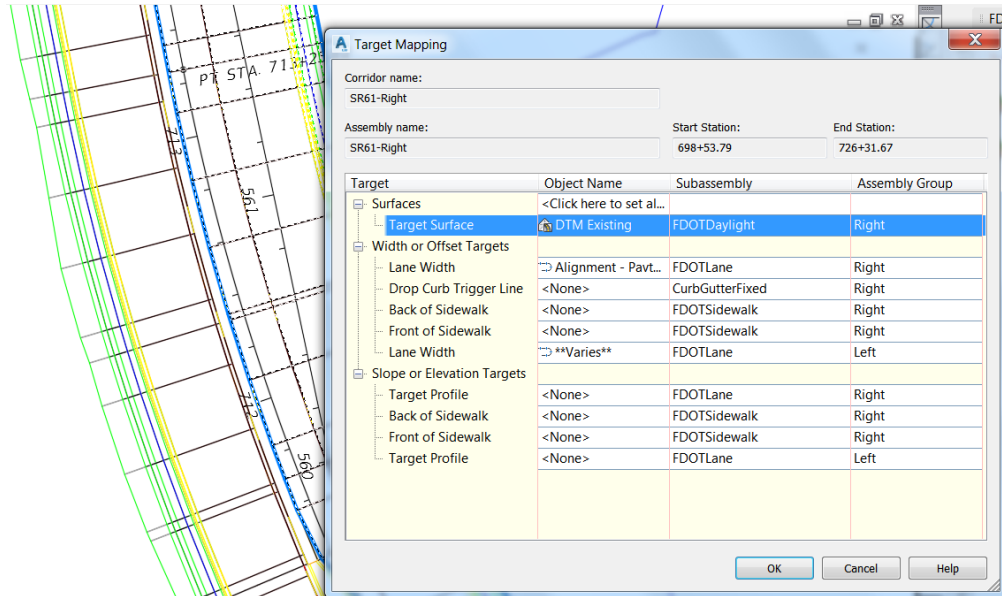

- Set the corridor region limits to the station range between intersections. Grip the SR61-Right corridor model. Zoom to the north end of SR61. Pick the diamond grip and drag it south to the traffic separator. Pick to reposition the grip to a point near the north traffic separator. Do the same for the SR61-Left corridor model region. The positions are not intended to be exact. If you prefer you may snap to a station label tick mark to place the grips.

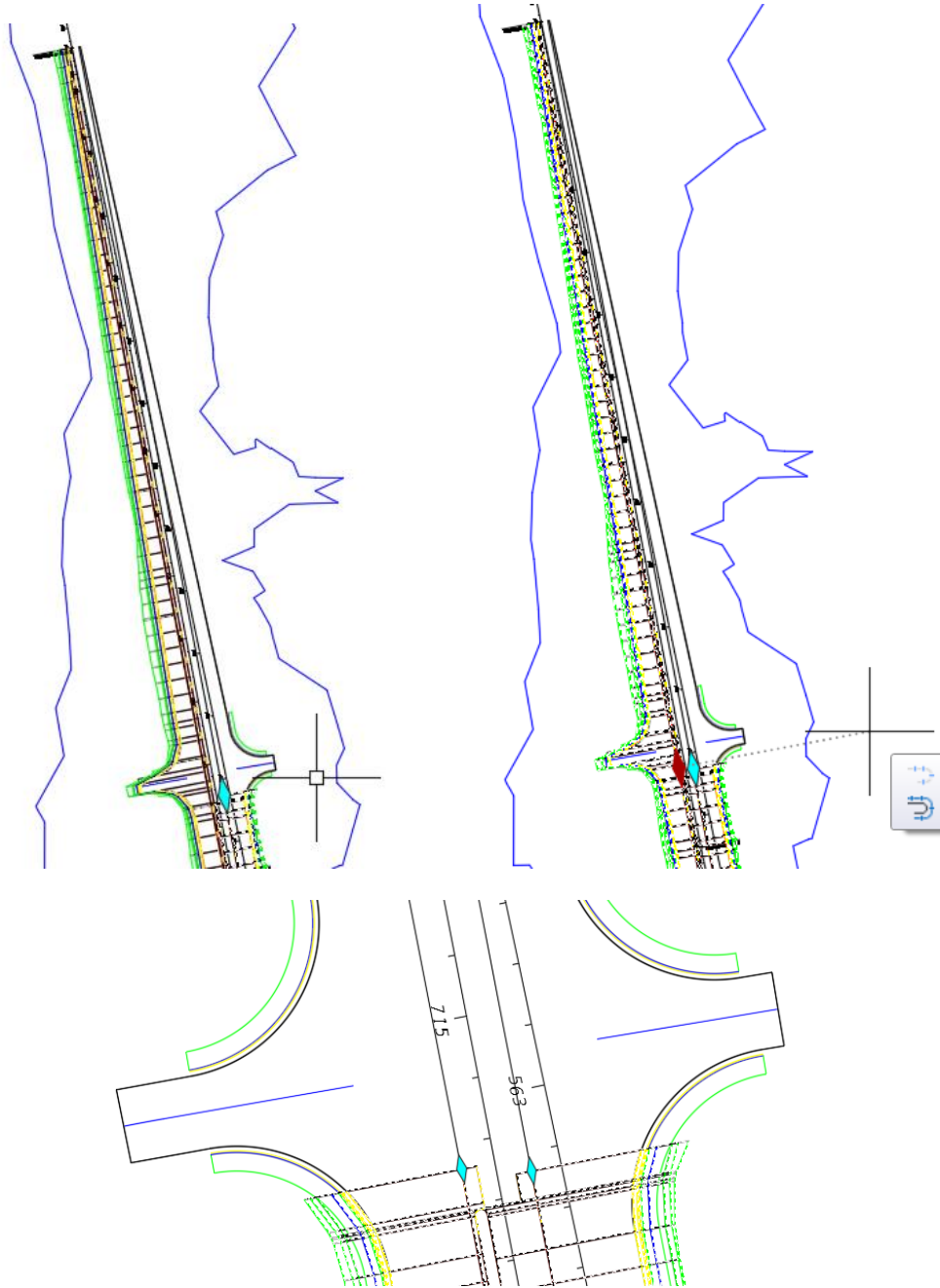

10. Set the corridor region limits on the south side of SR61. Zoom to the intersection of US98 and SR61. Pick the diamond grip on the SR61-Left corridor and drag it northwest. Snap to the alignment label tick at station 701. Do the same for the SR61-Right corridor region. You no longer get the error messages in the Event Viewer. Close the Panorama. Press ESC.

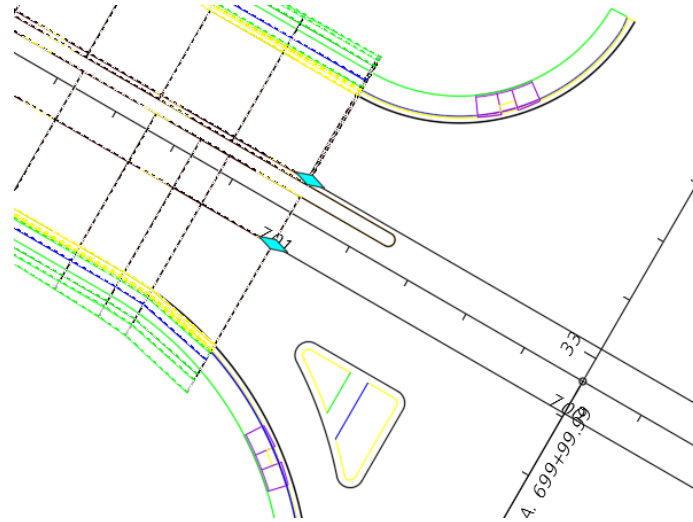

11. Restore the Plan view

12. **Save** the MODLRD02.dwg

10 Create SR61 Final Surface

DESCRIPTION

In this Chapter you will create a corridor surface on the left side of SR61 then combine the surfaces on the left and right sides of SR61 into a SR61 Final Surface.

OBJECTIVES

In this Chapter you will:

- Create a corridor surface.
- Paste SR61-Left surface to the Final Surface.
- Review the SR61 Final surface results in the Object Viewer.

CHAPTER SETUP

Run the Chapter 10 - 22049555201.exe file and restore all files to the C:\Civil 3D 2017 Projects folder.

Do not change the location in which the Practice Files are installed. Doing so can cause errors when completing the exercises in this training manual.

Exercise 10.1 Create MODLRD02.dwg

In this exercise you will create the MODLRD02 file to be used to create Surfaces.

1. From the **Select File** dialog box, navigate to the *C:\Civil 3D 2017 Projects\22049555201\Roadway* folder and select **10.1 - Creating SR61-Left Corridor Surface.dwg**. Click **Open**.
2. Right click the drawing tab and click **Save As**. From the **Save Drawing As** dialog box, navigate to the *C:\Civil 3D 2017 Projects\22049555201\Roadway* folder and type **MODLRD02.dwg** for the File name. Click **Save**.
3. Associate MODLRD02.dwg File to the Project. From the *TOOLSPACE > Prospector tab > Data Shortcuts [C:\Civil 3D 2017 Projects\22049555201]*, right-click and select **Associate Project to Current Drawing**.

Exercise 10.2 Create SR61-Left Corridor Surface

In this exercise you will use the SR61-Left Corridor Properties dialog to create a corridor surface.

1. Expand the Corridors collection in the Prospector. Right click on SR61-Left. Click Properties.

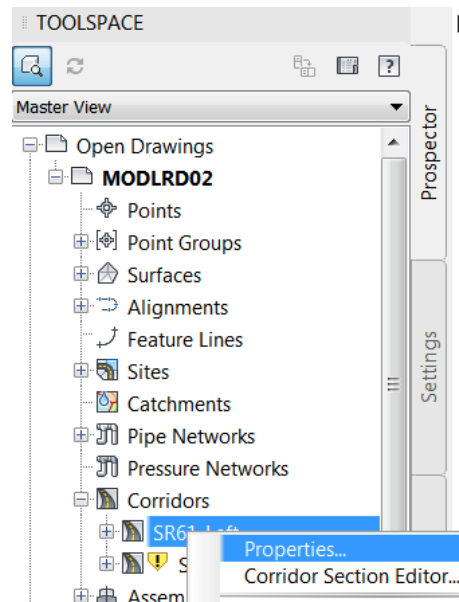

- Click the Surfaces tab. Click the Create a corridor surface button. Edit the surface name to SR61-Left. Click + Add surface data. Click the Boundaries tab.

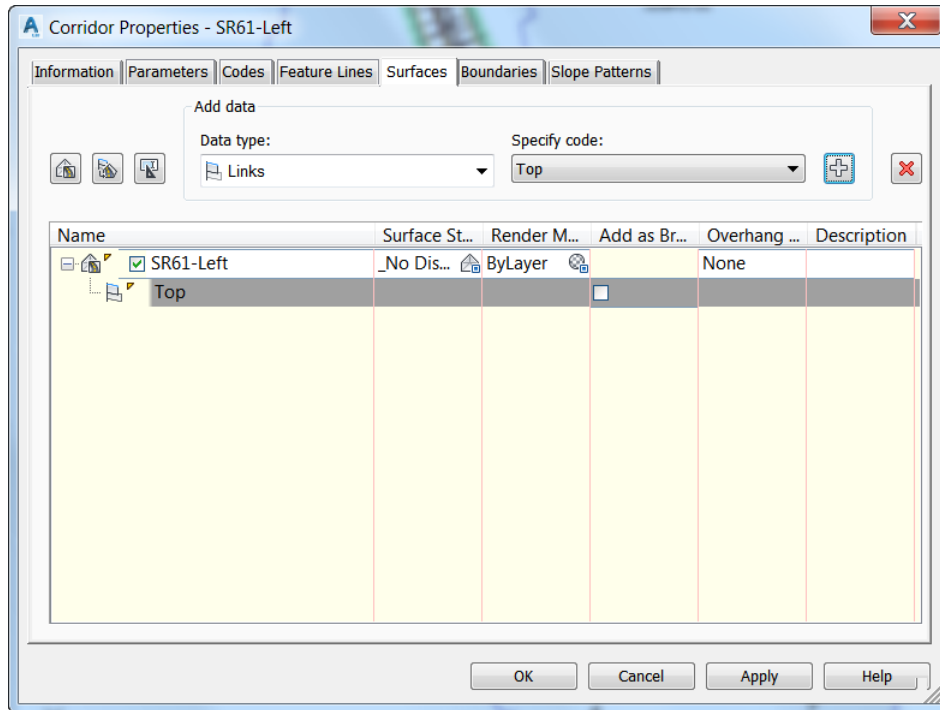

- Add a surface boundary. Right click SR61-Left and click Corridor extents as outer boundary. Click OK. Click Rebuild the corridor. Click Save.

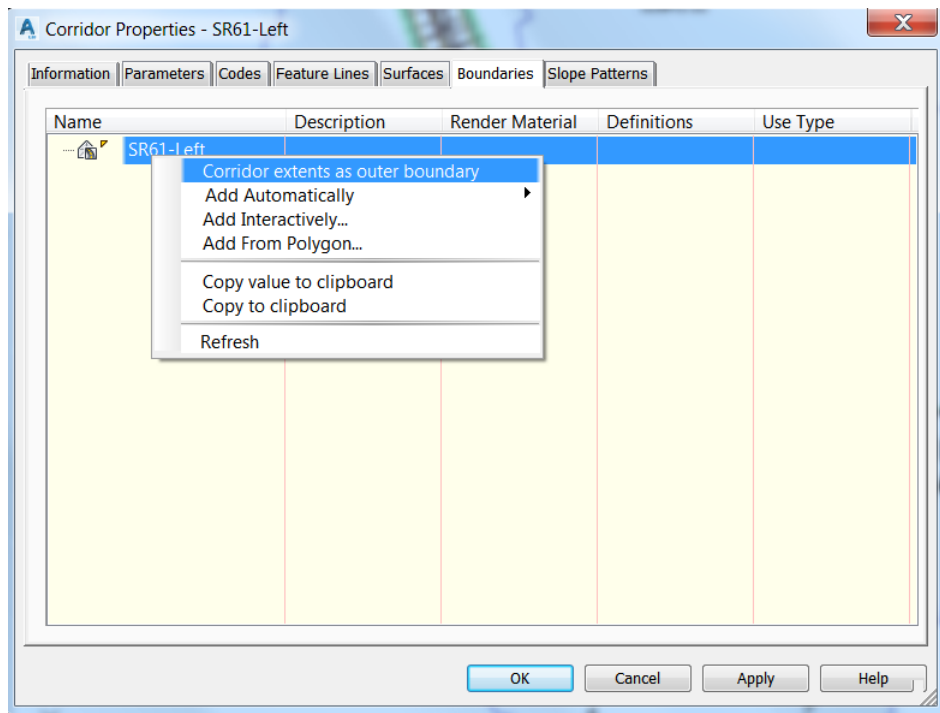

Exercise 10.3 Create a SR61 Final Surface

In this exercise you will combine the DTM Existing, SR61-Left, and SR61-Right surfaces in a new surface called SR61 Final.

1. Continue working in the MODLRD02.dwg In the Prospector right click the Surfaces collection. Click Create Surface. Type SR61 Final in the Name field. Click OK.

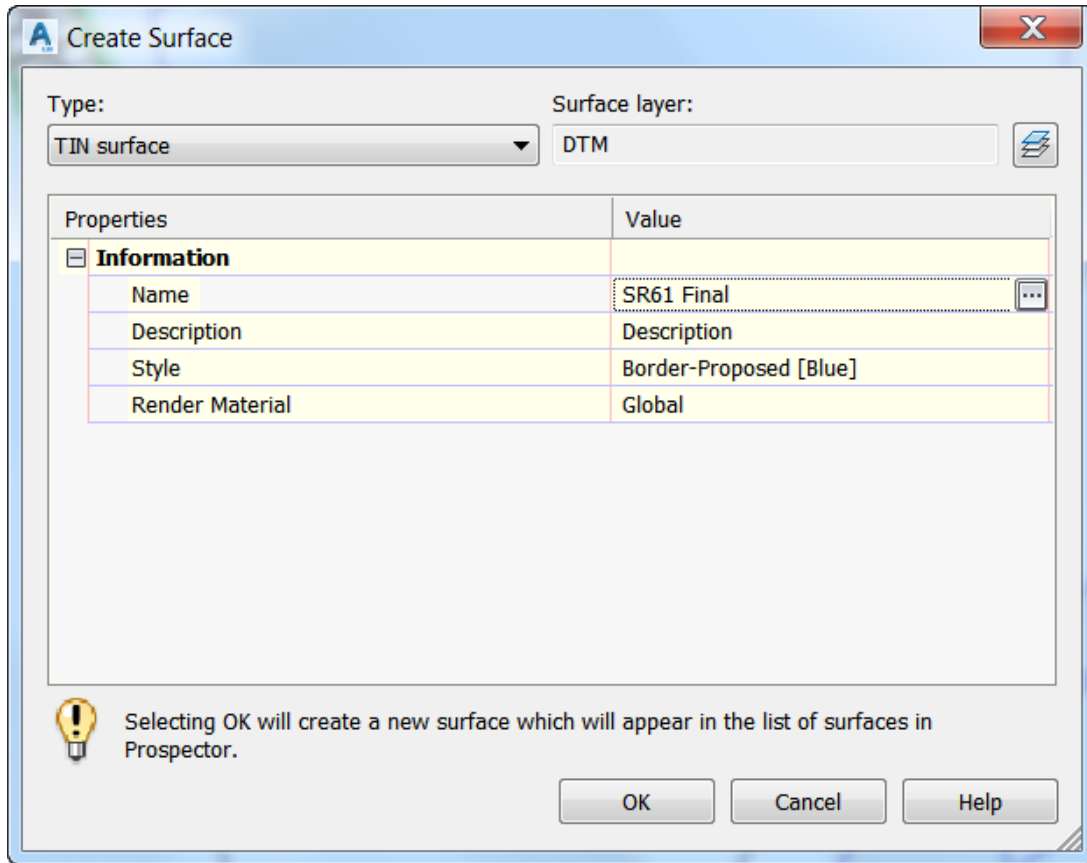

- Expand the Surfaces collection. Expand the SR61 Final. Expand Definition. Right click Edits and click the Paste Surface command.

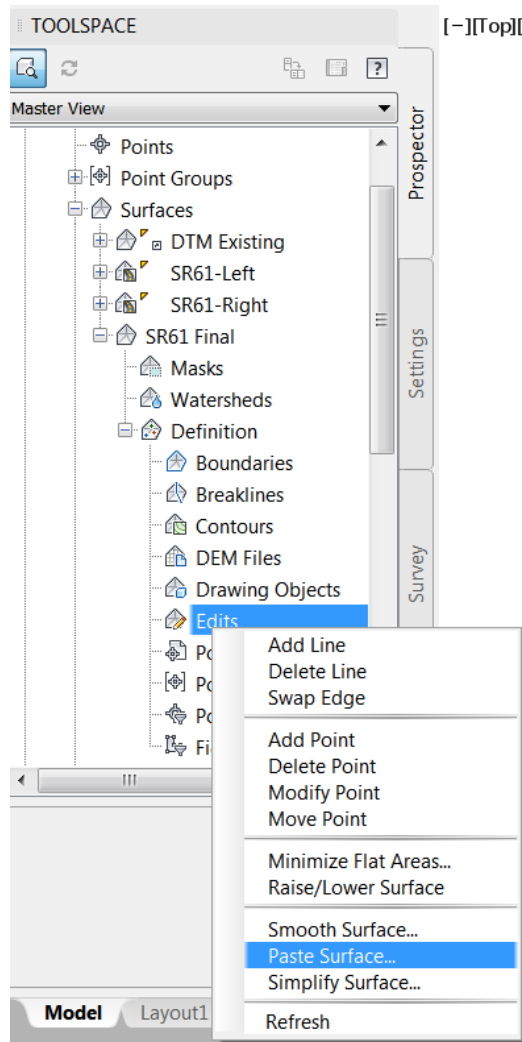

- Select all the surfaces in the list. Click OK.

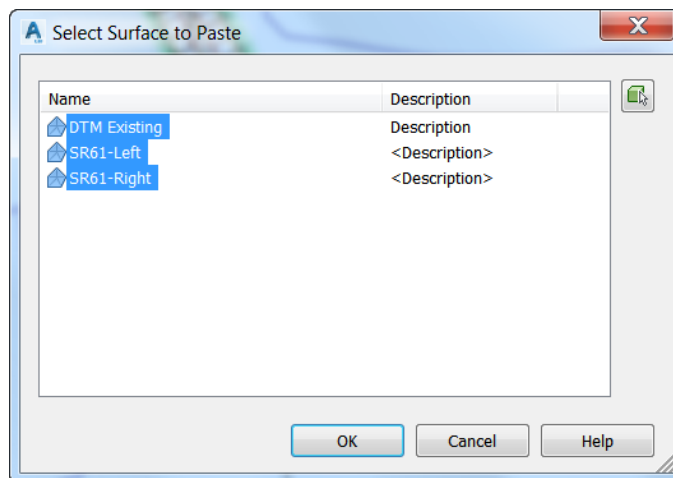

- Right click SR61 Final surface. Click Surface Properties. Click the Definition tab in the Surface Properties dialog. In the Operation Type area of the dialog you see the surface names added to the SR61 Final surface. The Paste Surface command will add each surface one at a time in the order they appear in the Operation Type list. The correct order is to have the existing surface added first. The Paste Surface command will use each surface boundary as a cutting object to remove data within the boundary and replace it with the data of the surface being added to the destination surface.

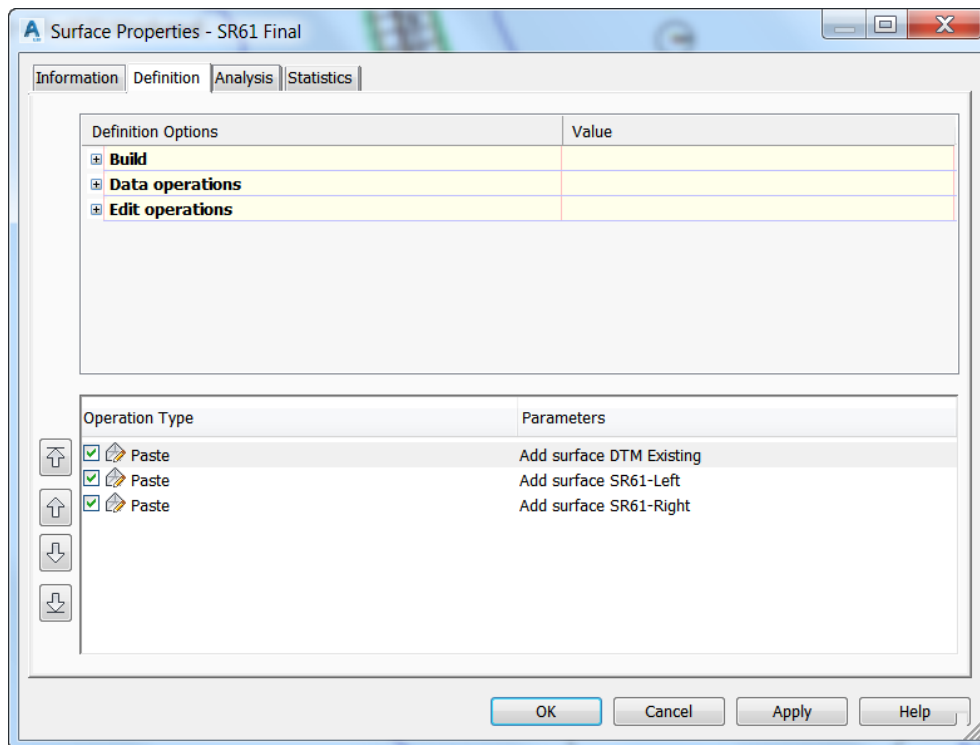
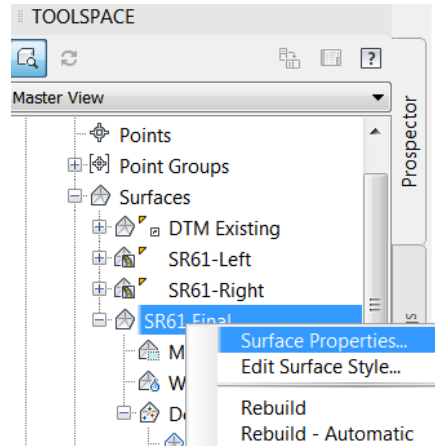

- Review the SR61 Final surface. Click the Information tab in the Surface Properties dialog. Set the Surface Style to Triangles Exag 3-1 Proposed. Click Save.

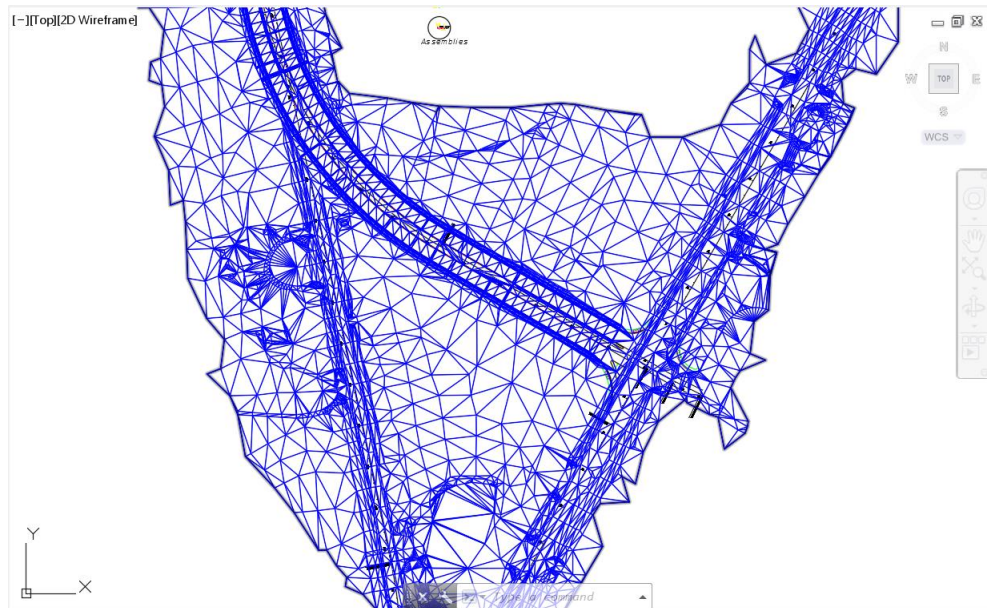

- Pick a triangle edge to select the surface. Click the Object Viewer command on the General Tools panel in the ribbon. Select Shaded with edges from the Visual Styles drop-down list. Select NW Isometric from the View Control drop-down list. Click the Zoom Window button and zoom to the intersection at the North Traffic Separator. The DTM Existing surface forms the base. The SR61-Left and SR61-Right surfaces are pasted on top of the DTM Existing. The voids at the traffic separators and median still have elevation data from the DTM Existing surface.

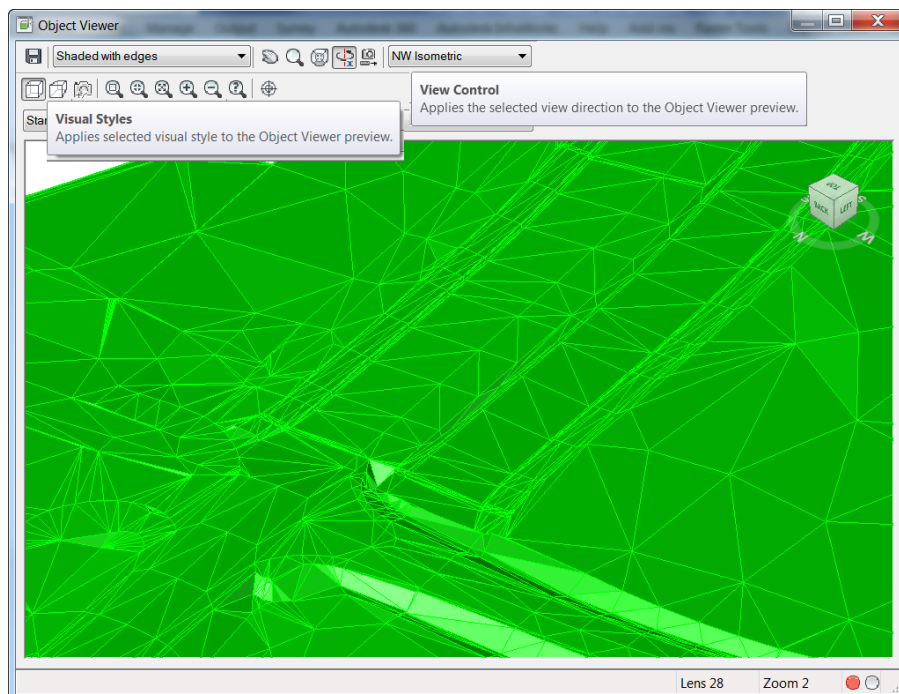

- Click the Save Image button in the upper left of the Object Viewer. Save the file SR61 Final.png in the Roadway folder of the current project. Close the Object Viewer.

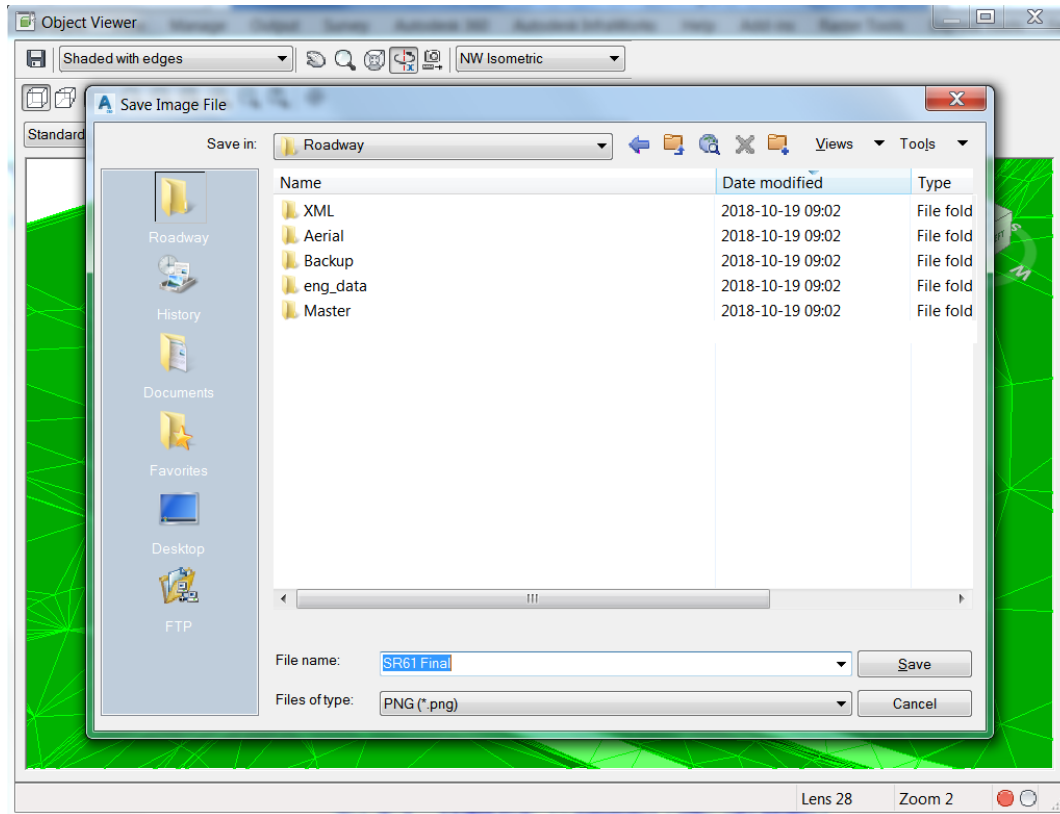

- Set the style of SR61 Final surface to Triangles 1-1 Proposed (Blue). Click the Surfaces collection in the Prospector to display the list of surfaces in the item view (the lower part of the Prospector). Click the surface style next to SR61 Final to open the Select Surface Style dialog. Select Triangles 1-1 Proposed (Blue) from the drop-down list.

9. Right click the SR61-Right corridor in the Prospector and click the Drive command.

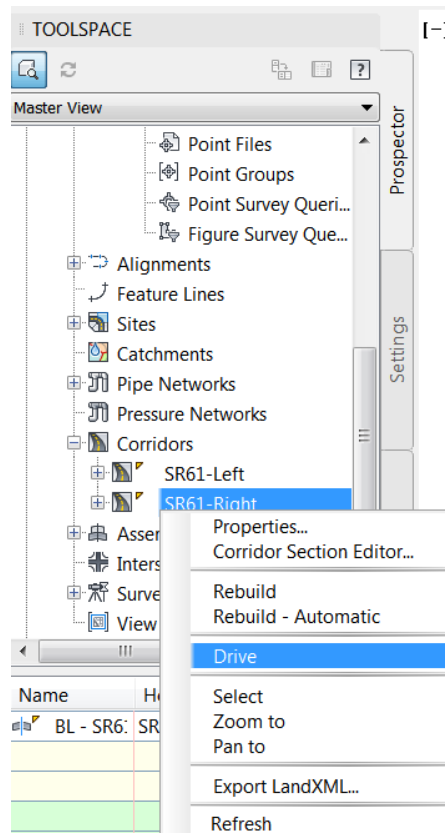

10. Zoom in to station 704. Pick the edge of pavement on the right side of the median.

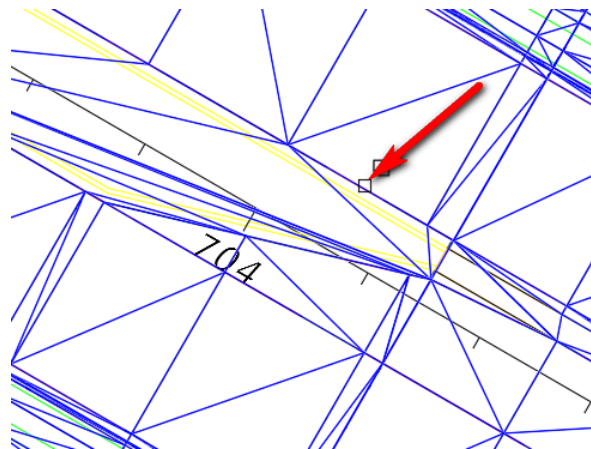

11. Select EOP from the list in the Select a Feature Line dialog. Click OK.

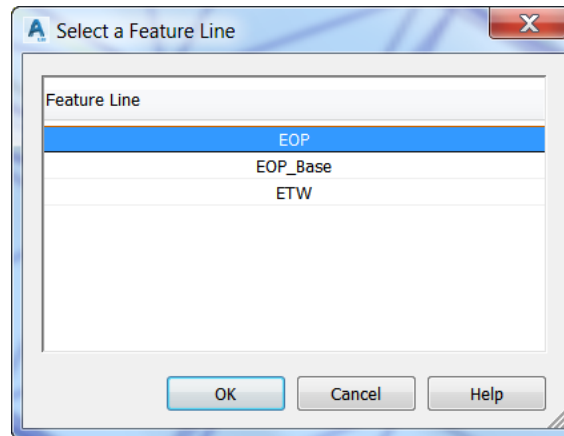

12. Click the Play/Pause button on the ribbon to start an animated drive sequence. Click the Close button on the right side of the ribbon.

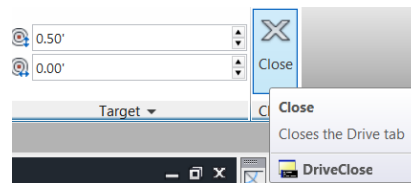
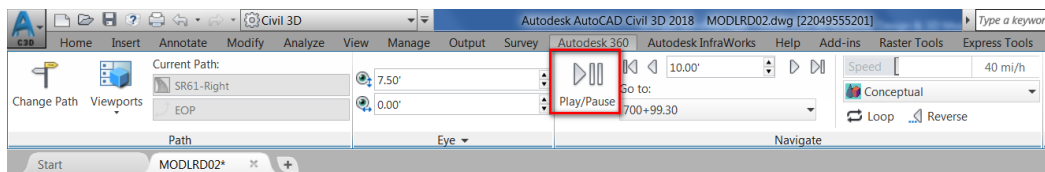

13. Set the style of SR61 Final surface to `_No Display`. Click the Surfaces collection in the Prospector to display the list of surfaces in the item view (the lower part of the Prospector). Click the surface style next to SR61 Final to open the Select Surface Style dialog. Select `_No Display` from the drop-down list. Click Save.

14. **Save and Close** MODLRD02.dwg.